



# HP DesignJet T730 Printer & HP DesignJet T830 MFP

Service Manual

Edition 2

© 2015, 2016 HP Development Company, L.P.

#### **Legal notices**

This document contains proprietary information that is protected by copyright. All rights are reserved. No part of this document may be photocopied, reproduced, or translated to another language without the prior written consent of HP.

#### **Warranty**

The information contained in this document is subject to change without notice.

**HP makes no warranty of any kind with regard to this material, including, but not limited to, the implied warranties of merchantability and fitness for a particular purpose.**

HP shall not be liable for errors contained herein or for incidental or consequential damages in connection with the furnishing, performance, or use of this material.

## **Safety**

The procedures described in this manual are to be performed by HP-qualified service personnel only.

### **Electrical shock hazard**

- Unplug the printer from the wall before performing any maintenance or servicing operation.
- Prevent water or any liquids from running onto electrical components or circuits.

### **Electrostatic discharge**

See [Electrostatic Discharge \(ESD\) Precautions on page 254](#) for actions you should take to prevent damage to the printer circuits from electrostatic discharge.

### **Safety symbols**

Serious hazards leading to death, injury, or damage may result if you do not take the following precautions:

- The Warning symbol calls attention to a procedure, practice, or the like, which, if not correctly performed or adhered to, could result in personal injury. Do not proceed beyond a Warning symbol until the indicated conditions are fully understood and met.
- The Caution symbol calls attention to an operating procedure, practice, or the like, which, if not correctly performed or adhered to, could result in damage to or destruction of part or all of the printer. Do not proceed beyond a Caution symbol until the indicated conditions are fully understood and met.



## Using this manual

This service manual contains information necessary to test, maintain, and service the following:

<b>HP DesignJet T730 Printer</b>	F9A29A
<b>HP DesignJet T830 MFP</b>	F9A30A



For information about using these printers, see the user's guide.

### **Readership**

The procedures described in this service manual are to be performed by HP Certified service personnel only.

### **Part numbers**

Part numbers for printer service parts are located in [Parts and diagrams on page 227](#).



---

# Table of contents

<b>1 Printer fundamentals .....</b>	<b>1</b>
Overview .....	1
Using the front panel .....	2
Start up process - preparing the ink system for the first time .....	4
Start-up sequence .....	5
Subsystems .....	7
<b>2 Troubleshooting .....</b>	<b>59</b>
Printer troubleshooting flowchart: SFP .....	60
Printer troubleshooting flowchart: MFP .....	61
Printer startup troubleshooting .....	62
Basic printer troubleshooting .....	64
System error codes .....	68
Paper troubleshooting .....	100
Communication troubleshooting .....	111
Manual driver installation .....	116
Drivers Troubleshooting .....	120
Ink-supplies troubleshooting .....	122
Print-quality troubleshooting .....	133
Print mode summary table .....	149
Printer Emulation .....	150
Scan and copy quality troubleshooting .....	151
The scanner diagnostic plot .....	168
Scanner jam removal .....	174
Scan media does not load .....	176
Update the firmware .....	176
<b>3 Support Menus, Diagnostic Plots &amp; Calibrations .....</b>	<b>181</b>
Support menus .....	182
Entering the support menus .....	182
Support menu .....	185

Extended Support menu .....	216
7. Scanner diagnostics (included only in Extended Support Menu) .....	219
Diagnostic Plots & Calibrations .....	222

#### **4 Parts and diagrams ..... 227**

Introduction .....	228
Printer stand .....	229
Stand HW SV kit .....	230
Covers HP DesignJet T730 Printer .....	231
Covers HP DesignJet T830 MFP .....	232
Roll covers .....	233
Right-hand assemblies .....	234
Left-hand assemblies .....	236
Carriage assembly .....	238
Paper path (front) .....	239
Paper path (rear) .....	240
Spindle .....	241
Sensor Kit .....	242
Cable Kit .....	243
Ink tubes (RIDS) and Ink Supply Station (ISS) .....	244
Scanner Lid .....	245
Scanner Bottom Mech .....	246
Scanner Bottom-EE .....	247
Scanner Back .....	248
Miscellaneous parts .....	249

#### **5 Removal and installation ..... 251**

Introduction .....	254
Customer Self Repair parts .....	256
Videos available .....	257
Recommended checks after replacing parts .....	257
Top window SFP F9A29-67007 .....	258
Front Cover .....	261
Right Cover MFP SV Kit F9A30-67011 .....	264
Left Cover MFP SV Kit F9A30-67012 .....	268
Roll Cover .....	272
Back Cover .....	275
Front Panel SFP F9A29-67008 .....	278
Central Cover .....	284
Upper-Roll Paper Guide .....	289
Left Roll Support .....	292



Right Roll Support .....	297
Encoder Strip .....	300
Printer NVM backup PCA .....	305
Power Supply .....	308
Main PCA .....	311
Paper Motor .....	317
Encoder PCA and Index .....	319
Encoder Disk .....	323
Trailing Cable .....	326
Service Station .....	334
Prime Pump .....	340
Carriage and Belt .....	344
Carriage Belt .....	351
Right Gear Train Module .....	353
Starwheel Assembly .....	356
Output Shaft .....	358
Output Tray .....	365
Multi-Sheet Tray Assembly .....	367
Multi-Sheet Tray Assembly Extensions .....	368
Output Platen .....	370
Carriage Motor .....	374
Cutter Assembly .....	378
Multi-Sheet Tray Sensor Assembly .....	385
Out-Of-Paper Sensor .....	388
Out-Of-Paper Sensor Cable .....	392
Output Tray Sensor Assembly .....	395
Output Tray Extender Sensor Cable .....	398
Carriage Line Sensor .....	402
Bundle Board .....	406
Bundle Board FFC cable .....	408
Pinchwheels .....	414
Left Spittoon .....	420
Scanner Top Cover F9A30-67015 .....	423
Scanbars F9A30-67017 (HP DesignJet T830 MFP only) .....	425
Top Cover Button Latch F9A30-67016 (HP DesignJet T830 MFP only) .....	430
Bottom Platen F9A30-67042 .....	431
Scan Bundle Board F9A30-67029 .....	433
Scanner Feed Motor F9A30-67024 .....	435
Hinges F9A30-67019 (HP DesignJet T830 MFP only) .....	437
Scanner Feedshaft (Front) F9A30-67025 .....	440
Scanner Feedshaft (Rear) .....	446

Bottom Cables F9A30-67034 .....	448
OPT Wheel F9A30-60038 .....	453
Sensor SV Kit F9A30-67031 .....	454
Rear Cover (MFP only) .....	464
Scanbar FFC F9A30-67018 .....	466
Printer Sensor Kit SV .....	473
Calibration Surface F9A30-67027 .....	484
Calibration Slider .....	487
Calibration Surface Gear Train F9A30-67028 .....	489
Lower Pinch Assembly with Mirror F9A30-67033 (HP DesignJet T830 MFP only) .....	492
RIDS (Ink Tubes) .....	494
ISS .....	499
Front Window MFP SV Kit F9A30-67013 .....	502
Refeed Preventer .....	504
Scanner Module .....	505
Top Lid Mirror and Magnet (HP DesignJet T830 MFP only) .....	511
Input platen SV F9A30-67039 (HP DesignJet T830 MFP only) .....	513
Diverter SV F9A30-67040 .....	516
Diverter bottom part F9A30-67062 .....	520
Latch (Right) F9A30-67030 .....	522
Latch (Left) F9A30-67030 .....	524
Front Panel and Left Trim F9A30-67043 .....	526

**6 Preventive maintenance ..... 529**

Preventive maintenance .....	530
Preventive maintenance kits .....	537

**7 Safety precautions ..... 541**

General safety guidelines .....	542
Electrical / Fire hazard .....	542
Mechanical hazard .....	542
Warning labels .....	542

**8 Appendices ..... 543**

Important links .....	544
Support Menu and Extended Support Menu Tree .....	545
How to check whether your computer is connected to your network .....	546
Wireless troubleshooting report error cases .....	549
Media Advance Calibration report (Tap 11) .....	557
Rugged Case Accessory .....	561

CSR fliers .....	567
FAQ: Tips & Tricks .....	596



# 1 Printer fundamentals

- [Overview](#)
- [Using the front panel](#)
- [Start up process - preparing the ink system for the first time](#)
- [Start-up sequence](#)
- [Subsystems](#)

## Overview

Feature	HP DesignJet T730	HP DesignJet T830	More information
Paper source	Roll, Manual sheet, and Multi-sheet tray		See the user's guide
Hardware differences	Single function printer	Multifunction printer with integrated scanner	
Connectivity	Wi-Fi or Fast Ethernet Lan and USB Host (Printing from USB/Scan to USB)		Important! Cannot have both WiFi and LAN at the same time
Web Services	Automatic firmware upgrade  Printing by email  Customer Involvement Program (Printer use data sent regularly under customer acceptance)		The printer needs to be Internet-connected: For some configurations, the latest firmware release is needed. Manual firmware update is available in both printers via HP Designjet Utility (Windows) or HP Utility (Mac OS) and also via USB host. The same firmware file is used for T730 and T830.
Mobility	Mobile "In-Os" Print support: (IOS, Android), HP AiO App		See user guide
Print speed	28 s per page on A1/D in Economode	28 s per page on A1/D in Economode	
Default print mode	Fast		
Print resolution	Up to 1200 × 2400 dpi		
Memory and languages	1 GB, HP-GL/2 (processing in printer)		

Feature	HP DesignJet T730	HP DesignJet T830	More information
Supplies	Ink supplies HP 728 40 ml and 130 ml Cyan, Magenta, Yellow		Ink cartridges and printhead can be replaced by the customer.
	HP 728 69 ml and 300 ml Black		
	HP 729. One on Axis PRINTHEAD for all colors		

## Using the front panel



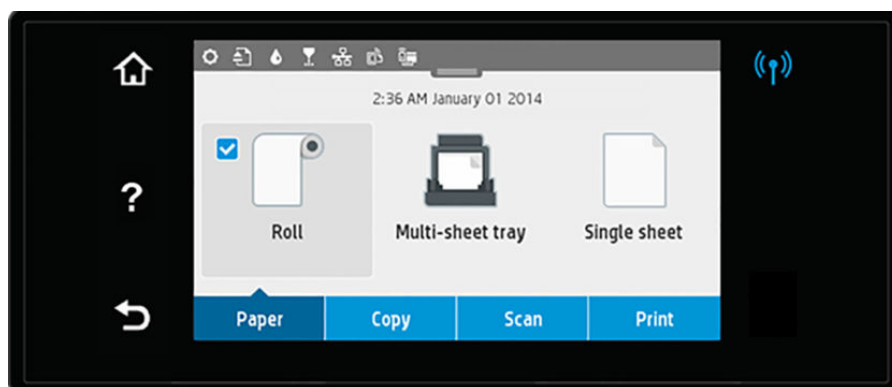

The front panel is a touch-sensitive screen with a graphical user interface; it is located on the front left of the printer. It gives you complete control of your printer: from the front panel, you can print, view information about the printer, change printer settings, perform calibrations and tests, and so on. The front panel also displays alerts (warning and error messages) when needed.



The front panel has a large central area to display dynamic information and icons. At the top of the central area there is a dashboard that displays the Home screen icons. To interact with these icons swipe across the dashboard to access the Home screen.



On the left and right sides you can see up to six fixed icons at different times. Normally they are not all displayed at the same time.

### Left and right fixed icons



-  shows the status of the wireless connection: if the blue light is shining, the wireless connection is active.
- Press  to return to the home screen.
- Press  to view help about the current screen.
- Press  to go back to the previous screen without discarding changes.

## Paper tab icons

The following items are displayed only on the paper tab screen:

- Press  to load, unload, and change options for roll paper.
- Press  to change options for the multi-sheet tray, or activate it.
- Press  to load, unload, and change options for single sheets.

---

 **NOTE:** The white tick in a blue box indicates the active paper source: in this example, the multi-sheet tray: .







 **NOTE:** It is not possible to use wireless and wired network connections simultaneously.

 **NOTE:** If no tick appears, no paper is loaded in any source.

---

## Dashboard icons

The following items are displayed only on the paper tab screen:

- Press  to change printer settings.
- Press  to eject paper from the scanner.
- Press  to view information about ink supplies.
- Press  to view information about the printhead.
- Press  to view information about network status, and configure the network (wireless or wired).
- Press  to access access Web Services.
- Press  to access WiFi Direct.

If the printer is left idle for some time, it goes into sleep mode and switches off the front-panel display. To change the time that elapses before sleep mode, slide , then **Printer setup > Sleep mode**. You can set a time between 5 and 240 minutes.

The printer wakes from sleep mode and switches on the front-panel display whenever there is some external interaction with it.









You can use the printer's auto-off feature to turn the printer off automatically. For example, setting it to 2 hours turns the printer off after 2 hours of inactivity. In this way, you can save more energy. However, the auto-off feature is automatically disabled when the printer is connected to the network, to avoid inconveniencing network users.

The following table shows an overview of the two types of support menu available, for more details see [Entering the support menus on page 182](#).

---

 **NOTE:** The icons mentioned in this table will not be visible in the front panel: you must press the front panel in the places where they normally appear, as shown in the front panel illustration at the start of this section.

---

Label	Description
<b>Support menu:</b> This can be used by customers under the guidance of phone call agents assisting remotely. Using this menu, customers can perform troubleshooting tasks and access printer information.	From the Home screen, press the following icons one after the other:     .  If there is a system error, you may not be able to reach the home screen. In this case, press the <b>Power</b> button and hold it down for 15 seconds.
<b>Extended Support menu:</b> Service engineers only	From the Home screen, press the following icons one after the other:     .

## Start up process - preparing the ink system for the first time

The printer tubes and PHA are shipped dry. To ready them to print, they must be filled with ink, and need servicing to make the nozzles wet, and manage air within the PHA.

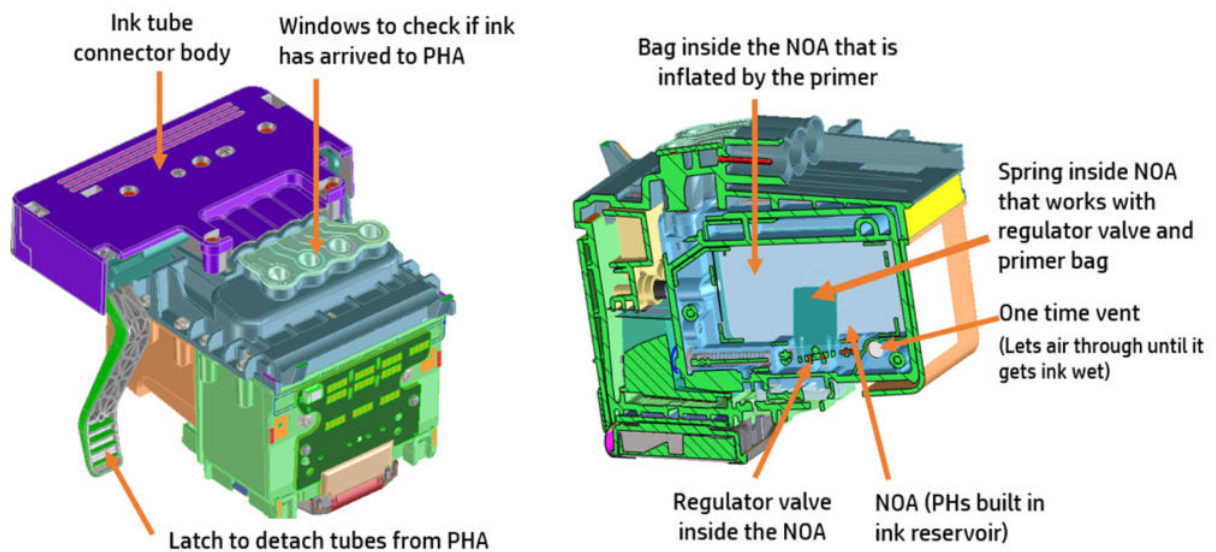

Three subsystems are primarily involved in this process: the ink supply station, the primer, and the service station.

- The ink supply station pumps ink from the supplies, through the tubes, to the PHA.
- The primer opens the PHA regulator to allow ink to enter the PHA. It also manages the air within the PHA, moving any air bubbles to the upper part of the **PHA reservoirs (also known as NOAs)**.
- The service station cleans the PHA nozzles after the process, readying the PHA for the first print.

The process flow is as follows:

1. The primer activates to inflate the bag inside the printhead so that the regulator is open during start-up. The primer air circuit holds the regulator open during the start-up ink fill process.
2. Once the regulator is open, the ink supply station starts pumping to push ink through the tubes. The first ink is used to fill up the empty tubes. The air in the tubes is purged out of the one-time vent in the PHA.
3. Once the tubes are filled, ink fills the NOA to the one-time vent. Air continues to purge out of the vent. When the ink reaches the one-time vent, it becomes wet and the air in the PHA remains. Extra ink is sent



for fully wetting the vent, and purge the air from the pores at which point the vent is closed and remains closed for the life of the PHA.

4. The air circuit is vented and the PHA bag is deflated. Now ink pumps in to return to the volume to what the bag had before moving from full inflation to set point. This closes the regulator.
5. With the PHA full of ink, a series of lower pressure primes are run to expel all air from the PHA below the filter into the NOA.
6. Finally the servicing routine begins, and the PHA nozzles are cleaned and prepared to print.

## Start-up sequence

There are 4 states between power-on and the Home screen:

1. Electronics initialization
2. Firmware initialization
3. Mechanical initialization
4. Scanner calibration

### State 1: Electronics initialization

1. The front panel moves from flashing white light to turning dark.
2. The printer reads the firmware from the eMMC module.

 **NOTE:** At this stage, if something is broken, it will not be possible to enter the Support menu. To diagnose what is happening, go to the front panel blank troubleshooting. [The Front Panel is blank \(the printer does not start\) on page 64](#). Subsequently, you can enter the Support menu to troubleshoot if necessary.

### State 2: Firmware initialization

1. HP logo appears on a white background.



2. Bundle board and ASICs are initialized. The Firmware is loaded.

3. When complete, the screen changes to:

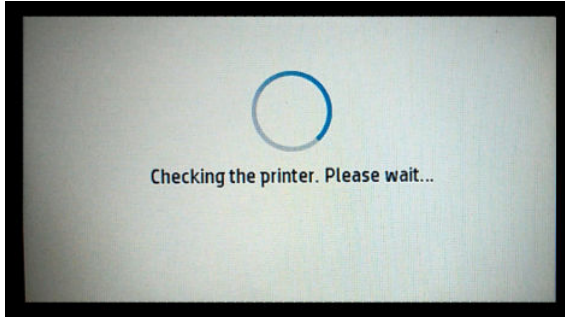

### State 3: Mechanical initialization

1. A basic check of servos is run.
2. Next, it checks that the Scan Axis and Paper Axis are unobstructed by scraps of paper or other items.
3. Finally the media and ink system are initialized.



---

**NOTE:** During all steps, the screen "Checking the printer. Please wait..." is shown:

---

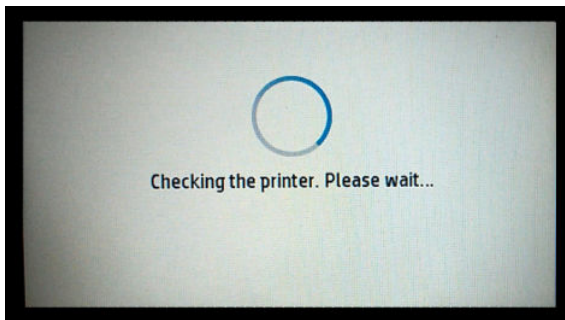

### State 4: Scanner calibration (MFP only)

- ▲ **MFP only:** Every time the unit starts up PRNU calibration (white balancing) is conducted to ensure best calibration and to improve IQ. During calibration, the following screen is shown:

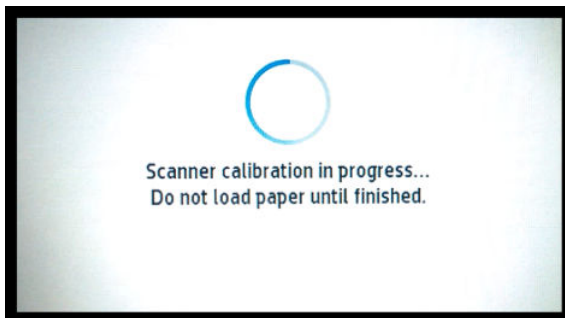

---

**NOTE:** Initialization lasts around 2 minutes with clean power-off (Front Panel Power button). If there was a dirty power-off, the printer requires more time to initialize to ensure the printhead is OK.

---

# Subsystems

## Printer

### Covers

#### Functionality

These parts cover the printing mechanism and act as protection from potential knocks or dust. They also prevent the customer from coming into contact with unsafe parts during the operation of the printer. Finally, the covers complement the style and aesthetics of the printer.

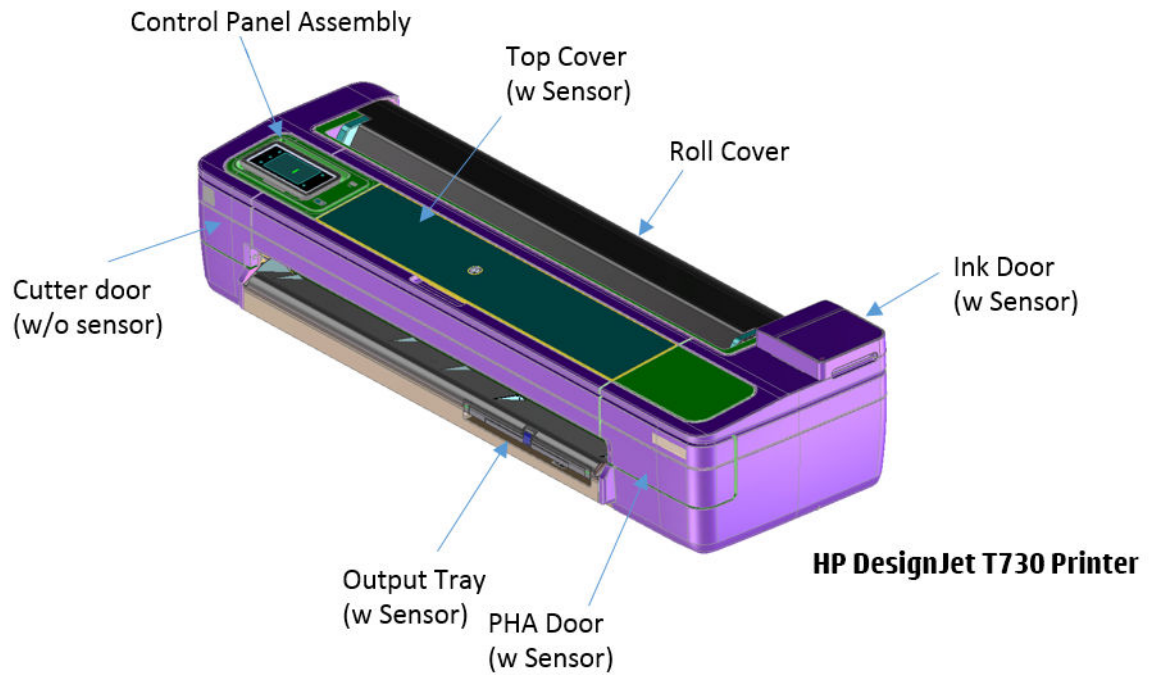

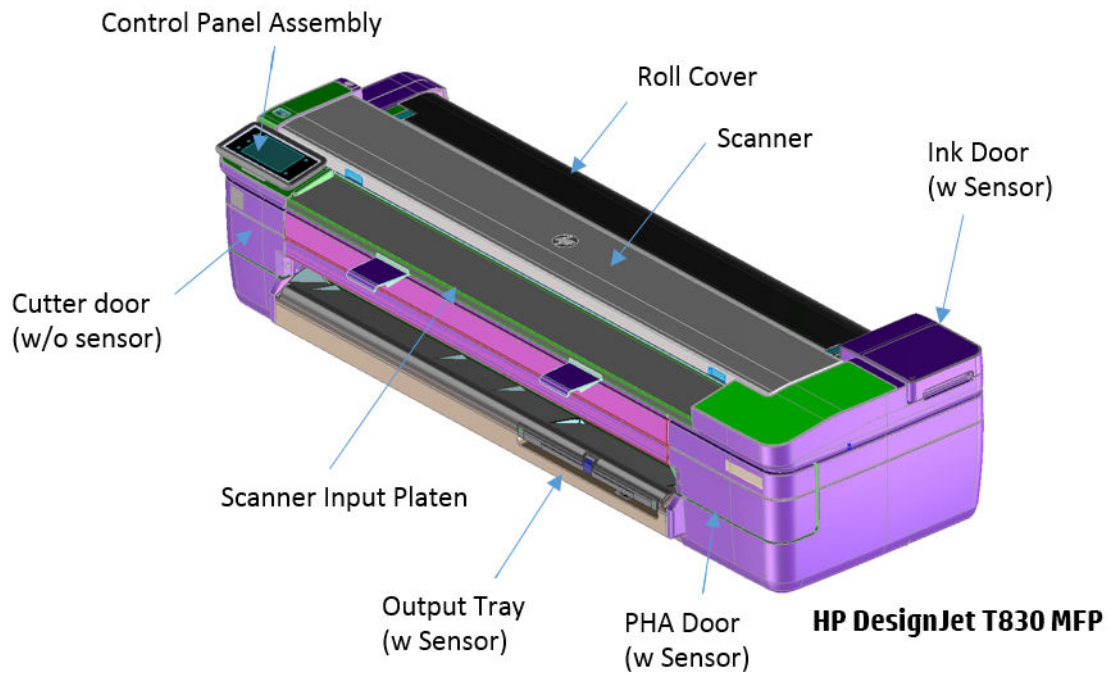

## Components

Other than the cosmetic aspects of the covers, there are several sensors related to the subsystem covers. The sensors are designed to detect the status of the cover, open or closed.

- The Ink Door Sensor senses whether the Ink Cartridge Cover is open or closed. Opening the Ink Cartridge Cover starts ink cartridge replacement automatically. The sensor is hosted in the printer chassis.
- **HP Designjet T730 Printer only:** The Central Cover hosts the Top Cover Sensor to sense whether the Central Window is open or closed.

---

 **IMPORTANT:** **HP Designjet T730 Printer only:** Be careful to avoid damaging the sensor while removing the Central Cover. See [Central Cover on page 284](#).

---

- The PHA Door sensor detects the door opening so that the printer is aware of the user's intention of interacting with the PHI connector or PHA.
- The Output Tray Sensor senses whether the Output Tray is open or closed. To avoid paper jams while printing on roll paper, the tray should be closed.

---

 **IMPORTANT:** Damage to the covers can cause the sensors to malfunction.

---

## Removal and installation

In order to proceed with the removal and installation of the covers it's important to bear in mind their cosmetic aspects. It is recommended that you use gloves for any service operation involving the covers.

Due to the layout of the covers, it is important to bear in mind that some parts require removal before you can remove a specific cover.

- Right Cover requires Front Cover removal.

---

 **IMPORTANT:** Right cover removal interacts with the ink tubes. There is only one way to remove the right cover; with the ink door open and the PHA door closed.

---

Ink door cover interaction with chassis:



- Right cover interaction with ink tubes:
  - With the PHA door closed, the tubes move freely:

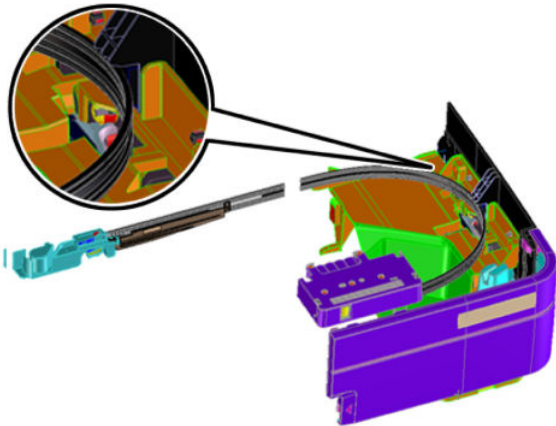

- With the PHA door open, the tubes are held by a lever:

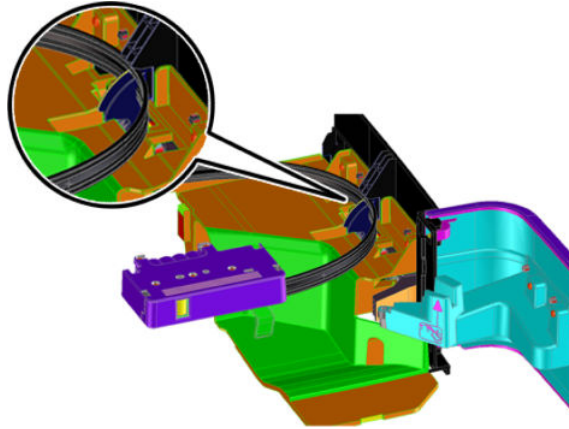

- Left Cover requires Front and Cutter Door Removal.
- Roll Cover requires Right and Left Cover removal.
- **HP DesignJet T730 Printer only:** Central Cover requires Right Cover and Left Cover removal.

## Electronics

Other than the sensor boards, there are no electronics related to this subsystem.

## Printhead health systems: Service Station, Primer system, and Left Spittoon

### Functionality

The service station is responsible for printhead maintenance. It takes action to clean ink residues and service ink nozzles, and prevents ink from drying in critical zones by capping the printhead once printing has finished.

The Primer system provides the necessary air pressure to the printhead to perform initialization. This system also provides pressure to the necessary printhead service operations (by boosting air which pushes ink out through the printhead nozzles, cleaning residues of dried ink and other particles).

The Left spittoon is a small container located to the left of the print-zone area, this is the area used by the printhead to “spit” a small amount of ink at the end/beginning of the printing swath in order to ensure correct nozzle health for left-to-right printing.

## Components

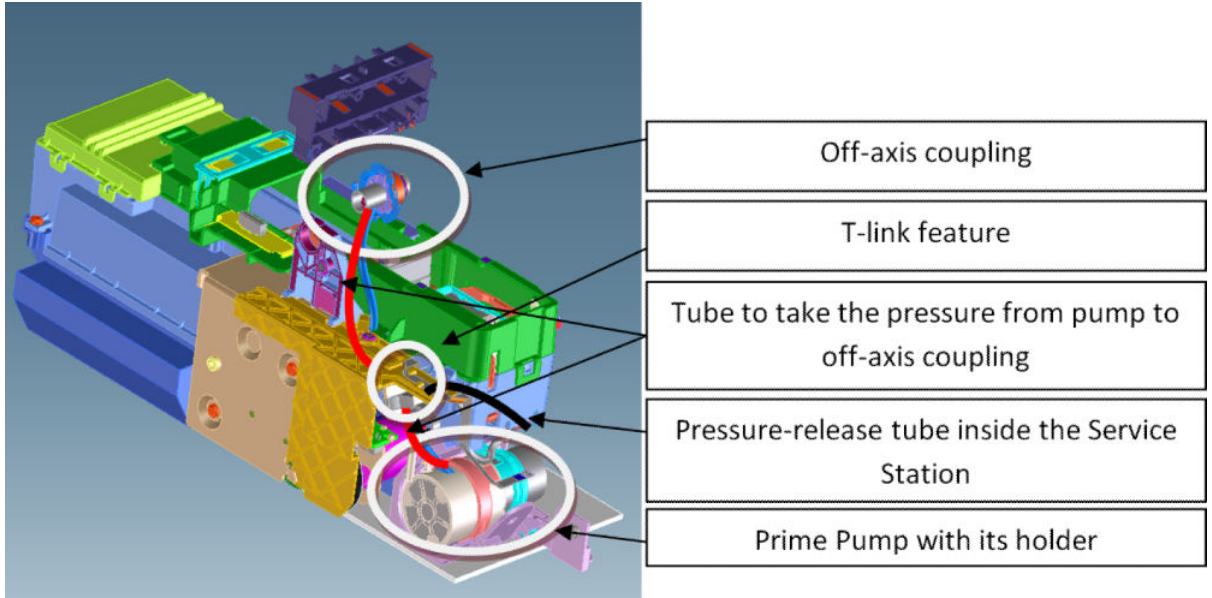

Item	Function
Off-axis coupling assembly	This is a rubber spring link located on the side plate of the scan axis (area where the Carriage moves). It links the primer system with the Carriage when the Carriage is located in its maximum left position. This system ensures the pressure from the primer reaches the printhead for nozzle servicing.
Prime Pump	This is an air pump which provides the necessary pressure for printhead servicing and nozzle repair. The Prime Pump is suspended on a rubber holder to minimize the noise that the Prime Pump makes while in operation.
Primer Tubes	The tubes take the air from the Prime Pump to the off-axis coupling. There is a T link feature connected to a tube that goes inside the service station; the purpose of this tube is to release the air pressure from the system. The tube is pinched by the shuttle of the service station when reaching a certain position; this action closes the circuit and allows the system to be pressurized. With the movement of the service station the tube is released, allowing the pressure from the system to escape.

## Notes and considerations

Any leakage in the primer system will generate poor or no priming, this will affect nozzle health (or even cause the printhead startup to fail). Bear in mind that the system is not just for the Prime Pump and tubes, the prime pressure is transmitted via the off-axis coupling to the Carriage and from there to the printhead assembly and from there to the cartridges.

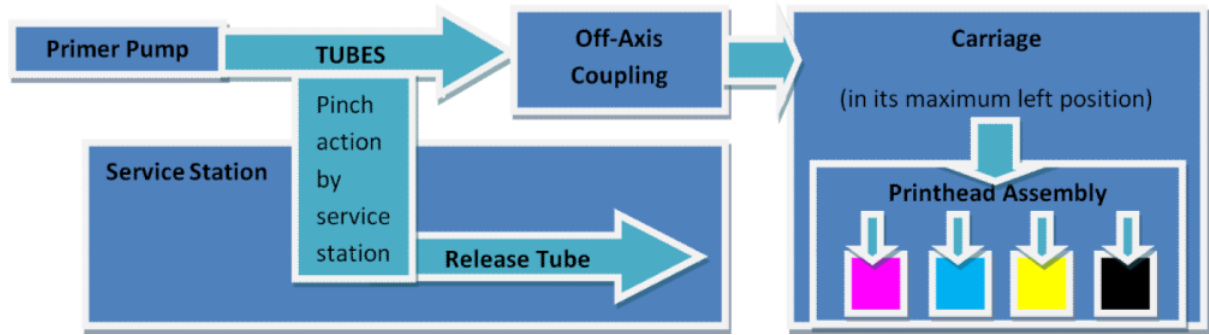

**NOTE:** There is no pressure sensor in the system. The Prime Pump operates at a certain time to reach a specific pressure level, the system is depressurized by releasing the pinching of the release tube in the Service Station (by moving the service station).

**NOTE:** It is important to ensure the Carriage reaches the maximum left position; if not, the off-axis coupling will not connect the Prime Pump with the Carriage. Also, the coupling is made of a rubbery material, degradation of the material will affect Primer performance due to air leaks.

## Electronics

The control driver of the Prime Pump is located on the printer bundle board located on the right-hand side of the printer. There is no encoder for the Prime Pump. This pump is managed only by a DC motor activated for a certain period of time to create the required priming pressure.

## Printhead assembly

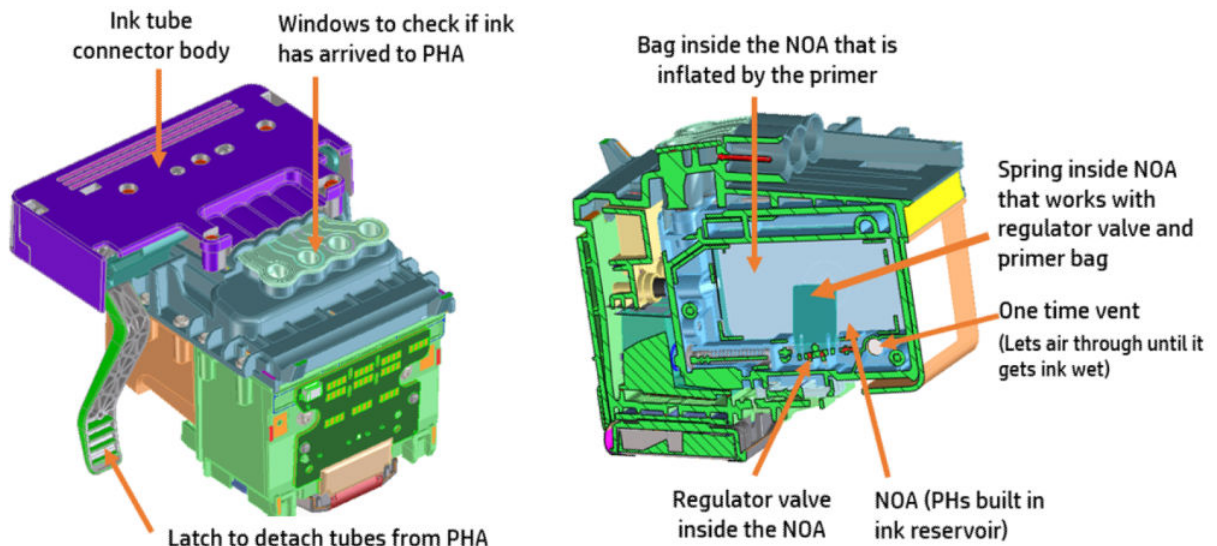

## Notes and considerations

The printhead operates as a full assembly, regulating ink flow in the NOA regulator, and warehousing air during the life of the PHA. This is done by balancing pressure between the inside of the NOA regulator and atmosphere. When ink is printed out, the pressure becomes more negative inside the chamber, causing the bag to open, which allows more ink into the system, putting it back into equilibrium and closing the regulator.

There are 4 colors on the die. With the PCA facing away from you, the color order is Black, Cyan, Magenta, and Yellow.



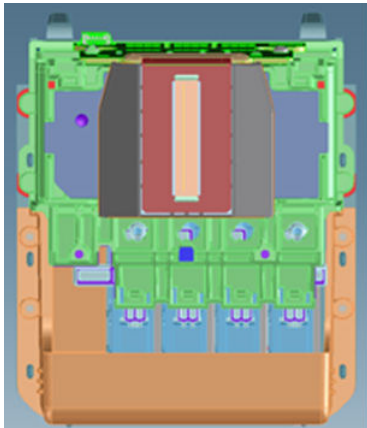

When the PHA is empty when replaced. The system uses the startup routine to fill the PHA and prepare it for the first page of printing. When performing a PHA replacement it is necessary to have enough ink in the cartridges, as prompted by the front panel. As noted in the section on the [RIDS \(Ink Tubes\) on page 494](#); when the tubes are empty, a new, empty printhead must be used.

---

 **NOTE: HOT SWAP is not allowed:** If the PHA is replaced with the printer turned ON, there is a risk of Main PCA damage if the printhead replacement front panel procedure is not followed.

---

## Electronics

The PHA is controlled through the carriage PCA and trailing cables to power the printhead and transmit data. It is connected on the backside of the carriage.

## Service Station system

### Functionality

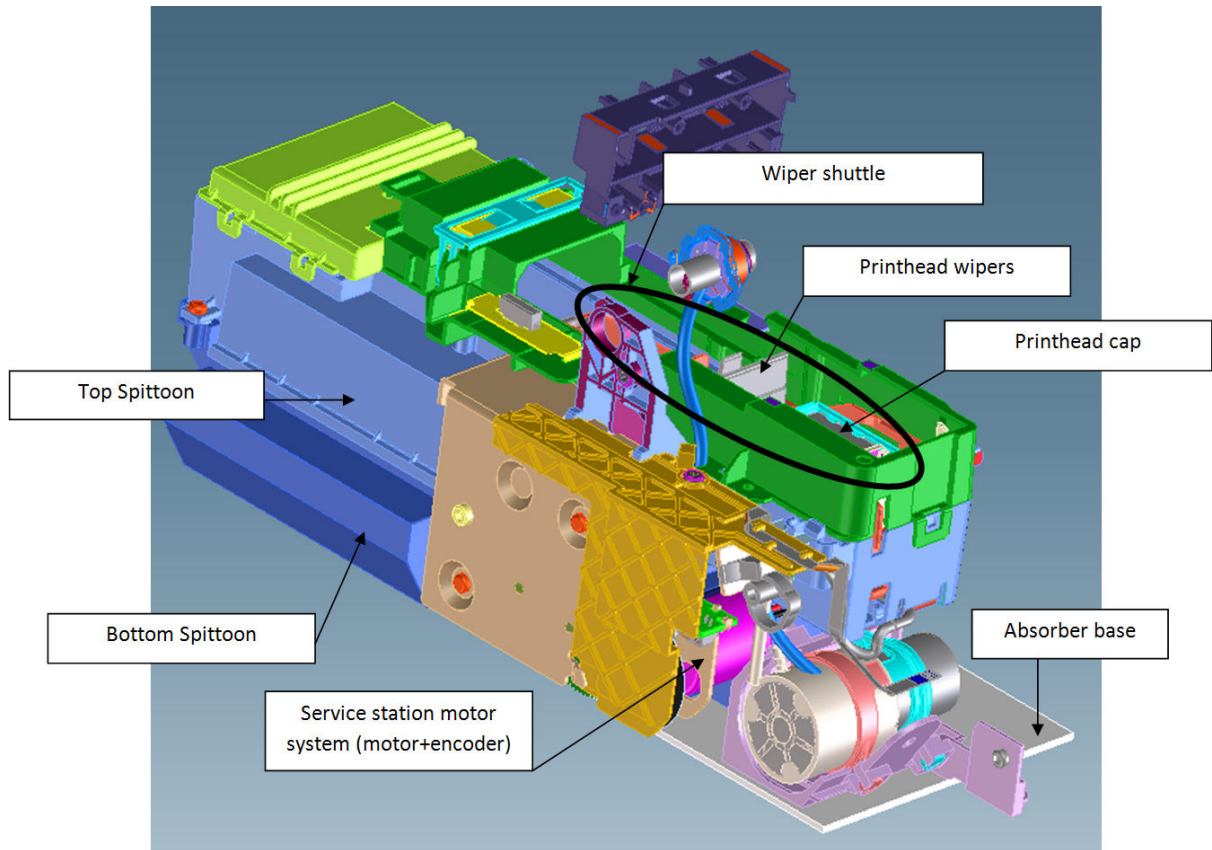

Item	Function
Printhead Wipers	These are rubber paddles that are passed through the nozzle plate of the printhead with the Service Station movement. They clean the excess ink from the nozzle plate with a rubbing action.
Printhead Cap	This caps and protects the nozzles from drying when they are not printing.
Service Station Motor system	This moves the shuttle with the wiper and the cap so that these two items can perform their functions. The system is composed of a DC motor and an encoder disk with an encoder sensor to read the motor position.
Bottom Spittoon	This part acts as an ink reservoir when spitting and nozzle health operations are performed. It contains diapers that absorb ink and keeps it contained.

Item	Function
Top Spittoon	This seals the reservoir and completes the main body of the service station.
Wiper Shuttle	<p>This mobile part is propelled by the motor that contains the Wiper and Cap. Depending on the position, spitting, wiping, capping, or priming can take place:</p> <p><b>Spitting:</b> The printhead “spits” a little ink into the spittoon to get the nozzles conditioned and ready for the next swath of printing.</p> <p><b>Wiping:</b> A physical action to pass the rubber wipers through the printhead nozzles.</p> <p><b>Capping:</b> Parking the printhead to maintain nozzle health during printer inactivity, with a surrounding seal.</p> <p><b>Priming:</b> Squirts ink through the nozzles to clean and unblock them.</p>

### Notes and considerations

The service station is offered as a complete service part for full replacement. The failures from this subsystem are usually related to the mobile parts: motor or encoder failures that prevent the shuttle from reaching the positions for capping or uncapping.

With the life primer system, tube pinching can present an issue (although it is designed to function for the life of the printer).

When the Service Station is replaced, it is mandatory to reset the Preventive Maintenance Kit for the Service Station, this will trigger a simple calibration that is done with the Service Station on the next printer startup. The calibration measures the length of the Service Station (shuttle front bump to shuttle rear bump), which ensures a correct capping position.

### Electronics

All the controlled movements for the Service Station are done from the Printer Bundle Board located on the right-hand side of the printer. Issues with the Service Station can also be related to this control board.

### Ink system overview

The ink system consists on the Ink Supply Station to pump ink from the supplies and the Ink Tubes to carry ink to the printhead.

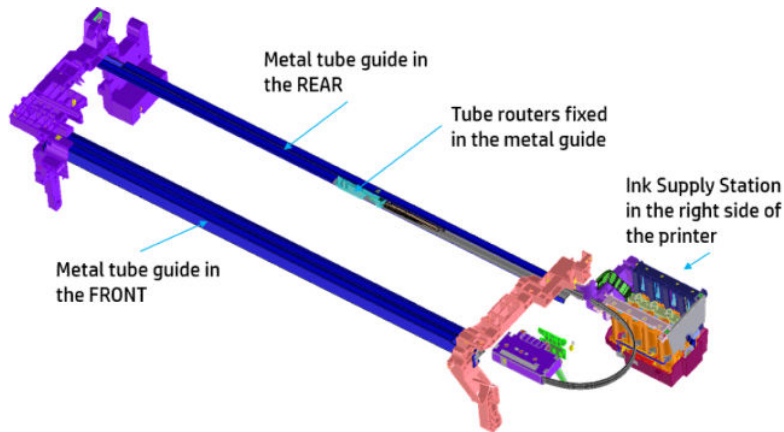

Below the two main systems mentioned are described.

## Ink Supply Station (ISS)

The Ink Supply Station (ISS) pumps ink from the supplies to tubes in order to print. The ISS acumen sensors identify HP ink supplies.

The ISS is mounted on the right of the printer so as to pump ink from the supplies to the PHA. Several of their main components are carry-over parts from other products.

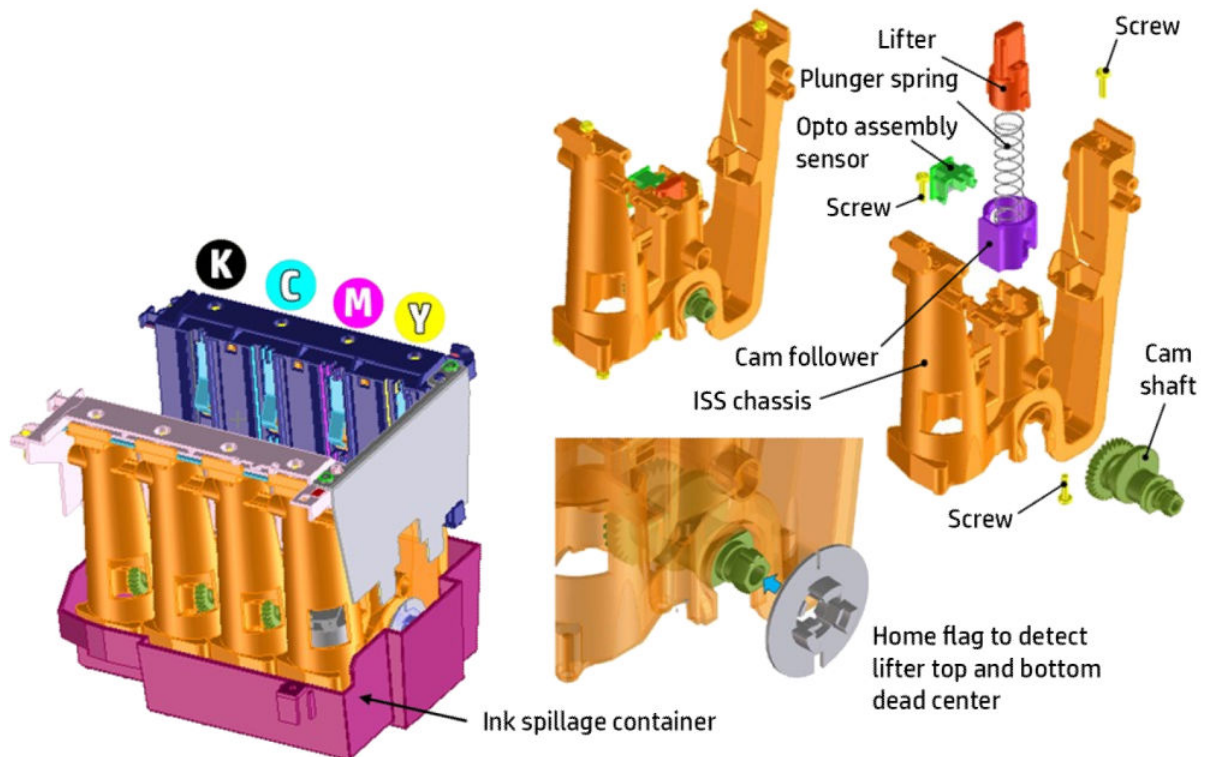

The ISS is designed to admit different supply types: Mirasis (130 cc), Mirasis Plus (300 cc) and Oasis (69 cc), with four different colors; Cyan (C), Magenta (M), Yellow (Y), Black (PK).

The Printer Bundle Board that controls the Primer, Ink Door Sensor, PHA Cover Sensor, Pick motor, ISS motor, ISS acumen sensor, ISS home flag encoder and Service Station motor is located just next to the ISS. The cables must be routed correctly (by means of wire saddles fixed in the Printer Bundle Board support), to prevent interference and wire pinching whenever the Right Cover is assembled.

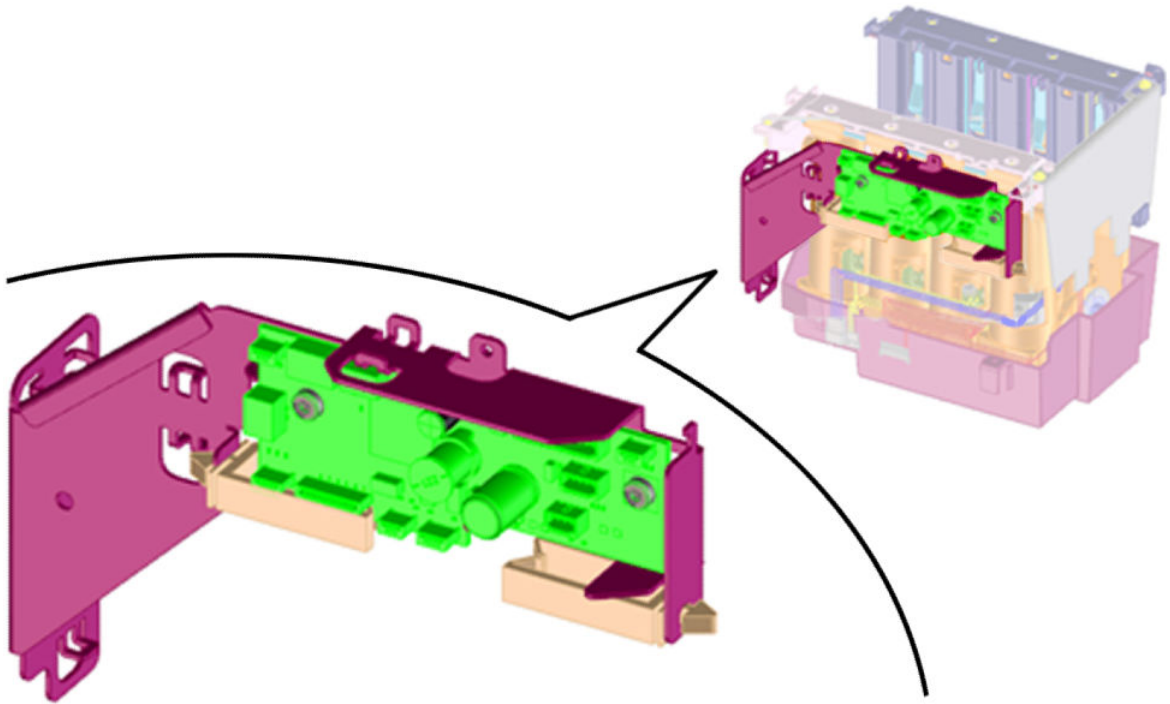

### Ink Tubes (RIDS)

The tubes connect the Ink Supply Station with the printhead and ensure ink is transferred from the supplies to the printhead. The tubes are independent of the Trailing Cables.

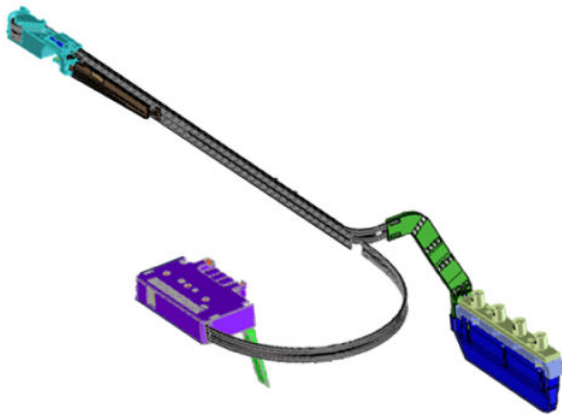

The PHA connector is not connected to the carriage, but a floating connector and the septums come pre-lubricated. Good lubrication is essential for easy insertion in the printhead.

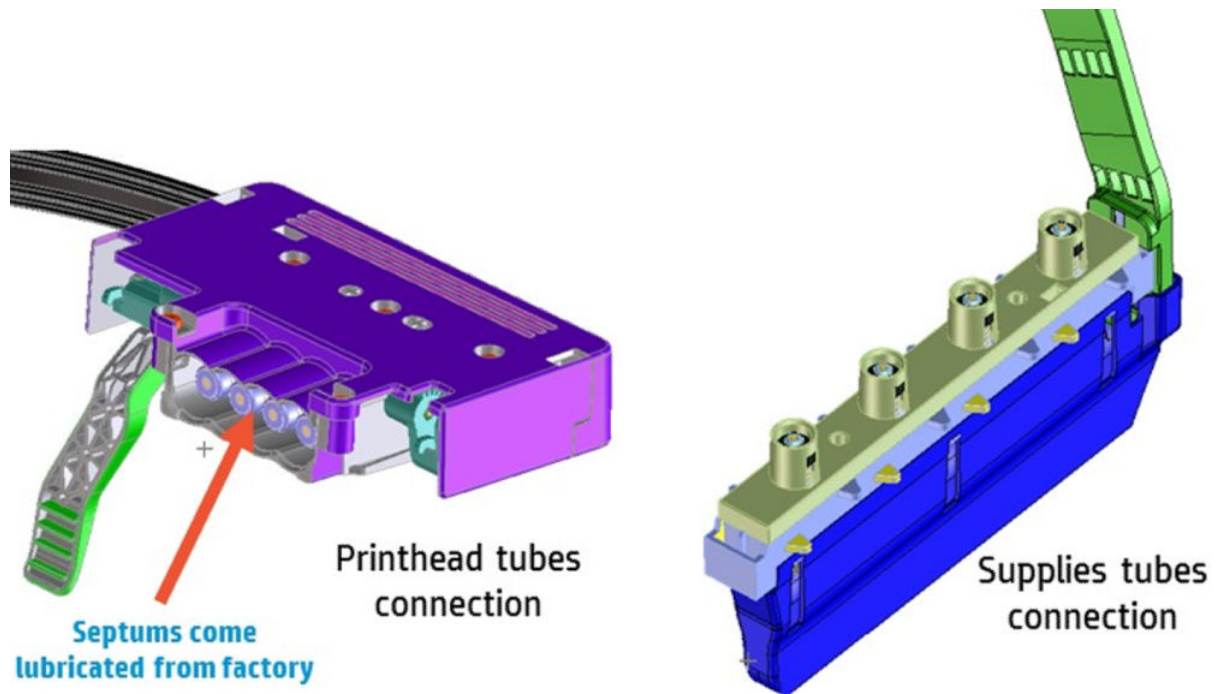

The supplies end is embedded in the Ink Supply Station and its design is very similar to other products. There is a risk that when removing the tubes from the printer some ink spillage can occur.

#### Printhead-Ink Tubes connection

This latch allows for the removal and installation of the off-axis ink tubes that go to the printhead assembly.

The ink tubes come connected to the printhead and are pre-installed in the carriage, but manual connection must be performed by the customer when a printhead replacement is required.

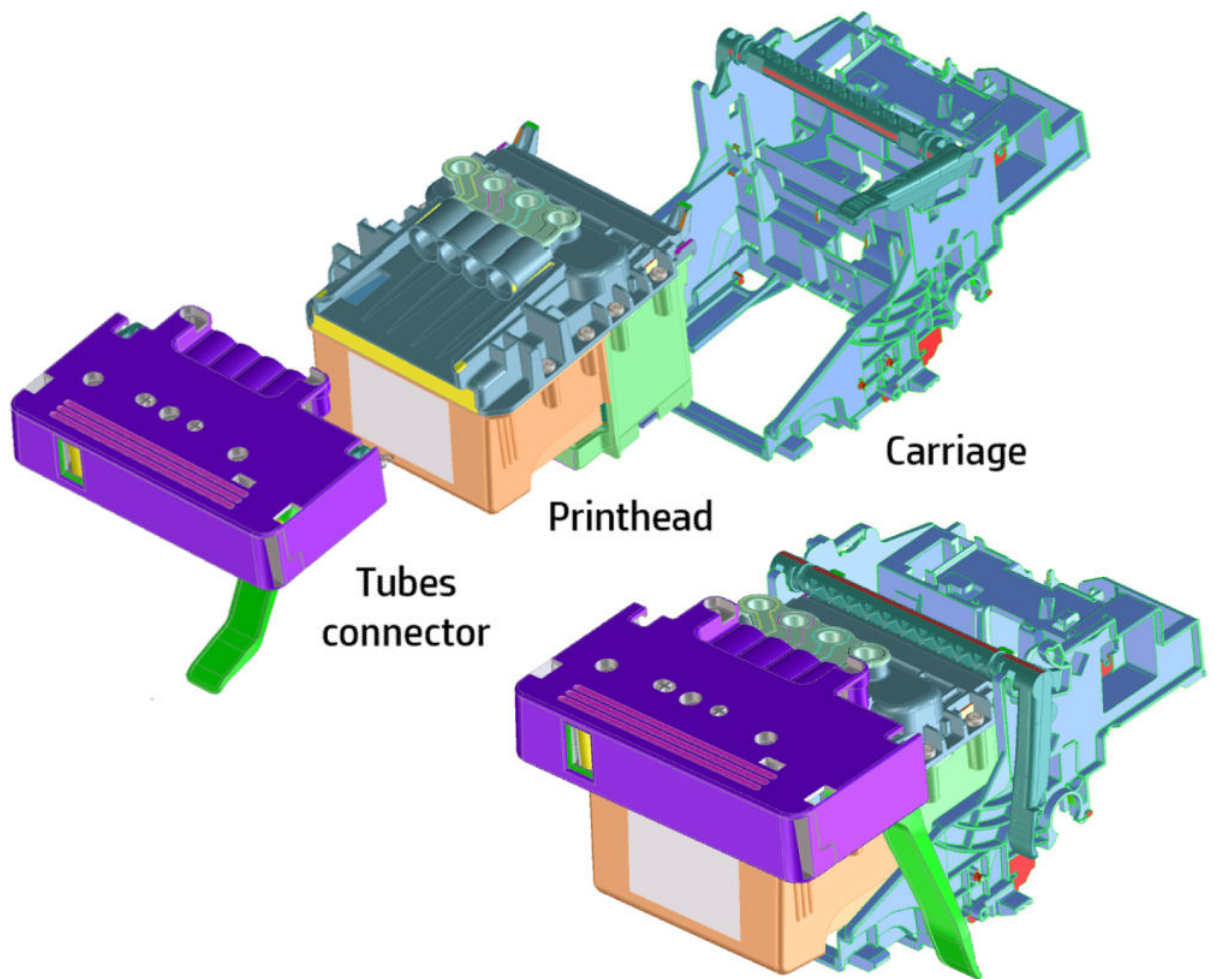

In order to help the user check if the tubes are well connected to the printhead, there is a locking indicator:

### Ink Tubes NOT PROPERLY Connected:

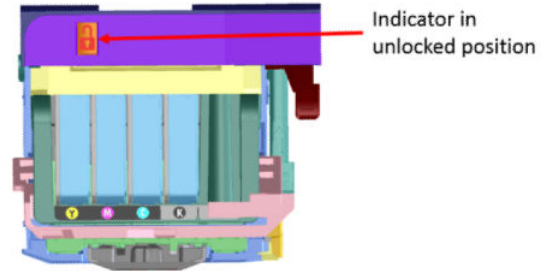
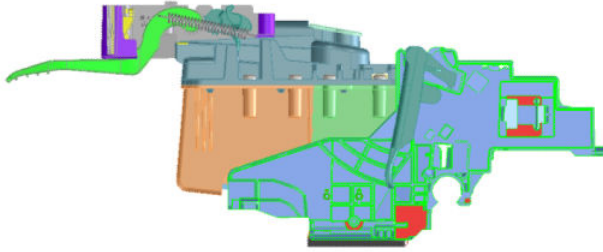

### Tubes Connected:

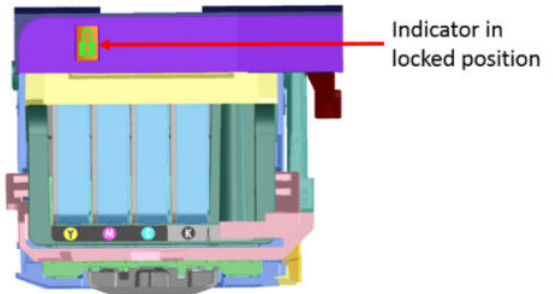

While printhead replacement is happening, it is important to handle the tubes carefully. Tubes should be left in the printhead door holder:

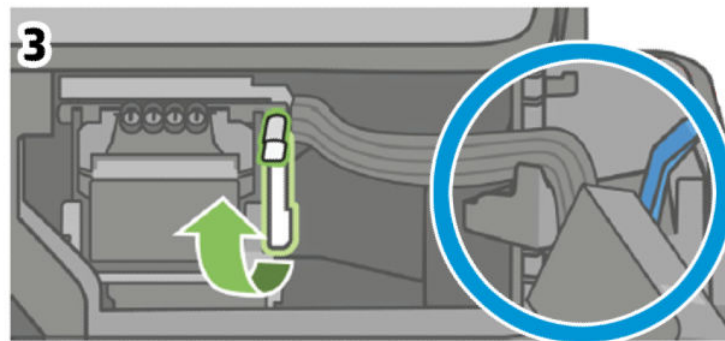
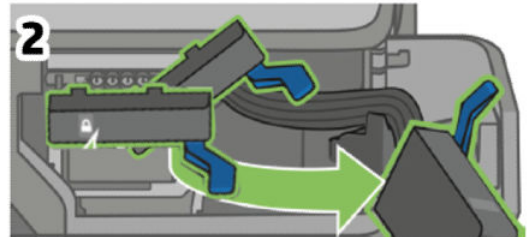
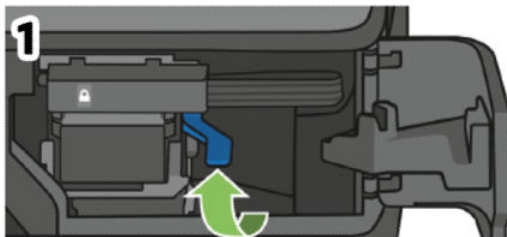

## Paper path and Cutter

### Functionality

#### The paper path

This comprises all the elements of the printer in contact with the paper, designed to hold, move, and manage it in a controlled manner in order to print.



Paper can be loaded using a roll, which is mounted on the rear spindle, or single sheets loaded from the Multi-Sheet Tray, or single sheets loaded singly.

The paper passes from its source (Roll, Single Tray, or Multi-Sheet Tray) until it touches the Out-Of-Paper Sensor, when the printer detects the presence of the paper and proceeds to load it.

To perform the paper feed, the printer catches the paper in between the Drive Roller and the Pinch Rollers (Pinch Rollers are spring-loaded pushing the paper down on top of the Drive Roller), then the paper is pushed forwards on top of the Print Platen in the print zone, which is where the printing operation is performed. The paper advance is provided by a motor that moves the Drive Roller. The exact position of the Drive Roller and hence the paper is controlled by an Encoder Disk located on the roller axis.

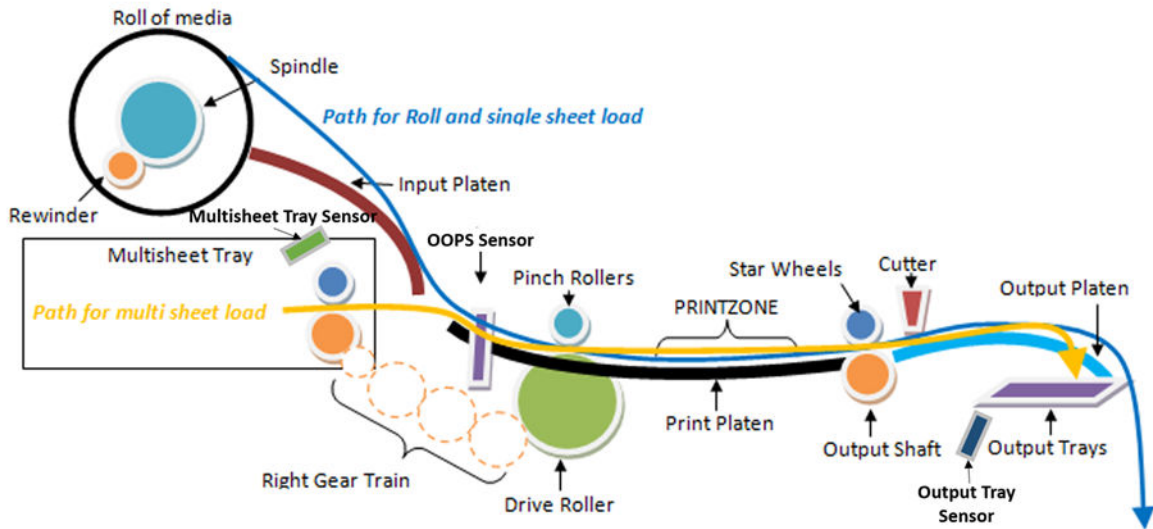

The printed paper then passes between the Output Shaft and the Starwheels (which keep the paper tension as flat as possible for printing) to exit on the Output Platen, where it is held in case of cut sheet or is cut to fall on the output basket in the case of roll paper.

The Output Shaft is designed to over-advance the Drive Roller movement slightly, and hence create the necessary paper tension to keep the paper as flat as possible. The Starwheels are spring-loaded and are designed to create force on top of the paper, this is done so as to leave the paper unmarked and at the same time allow the Output Shaft force to be appropriately transmitted.

In the Roll configuration, the rewriter module generates back force while printing to facilitate paper control.

A key electrical element of the paper path is the Paper Sensor (also known as the Out-Of-Paper Sensor or OOPS). This sensor is located at the beginning of the Print Platen; it detects paper insertion for roll load and single-sheet load.

## Electronics

In the paper-path driving system, the only electrically active element is the Drive Roller. The Drive Roller is impelled by the drive roller motor and it contains an Encoder Disk on the axis to determine its position. The Encoder Disk is read by two sensors. One, the “encoder sensor”, designed to read the encoder, counts the Encoder Disk (the Encoder Disk outer marks) and another one, the “encoder index sensor”, determines the start position (the 0 position) of the Drive Roller by reading the inner thicker lines of the Encoder Disk.

 **NOTE:** Every time the printer starts up, it searches for the 0 position of the Drive Roller. If this search fails (which means that the index sensor is faulty), the printer will give a system error and will be unable to initialize.

## The roll paper input system

### Functionality

This system keeps the roll in place and ensures controlled rotation.

It contains the rewinder, which rewinds the paper for paper ejection, and provides an opposite tension to the paper advance for better paper control.

- The Left Support encloses the Rewinder Motor and Encoder, containing a set of gears that transmit the Rewinder motion to the spindle. There is a V-shaped spring to load and fix the spindle in position.
- The Right Support holds the spindle in position to rotate over passive rollers. The right support also contains the damper for the roll cover opening movement control (the internal dampers perform a braking action preventing sudden movement during the opening operation).
- The spindle is designed to hold the paper rolls, and receive the motion from the rewinder gear in the Left Support. It consists of a central bar and two hubs; the right hub is fixed to determine the right-side loading position of the paper, and the moveable left hub adjusts to the width of the paper.
- The Roll Cover shields the roll from dust.



**NOTE:** The Roll Cover is a passive part, with no sensor: the printer does not know its status.

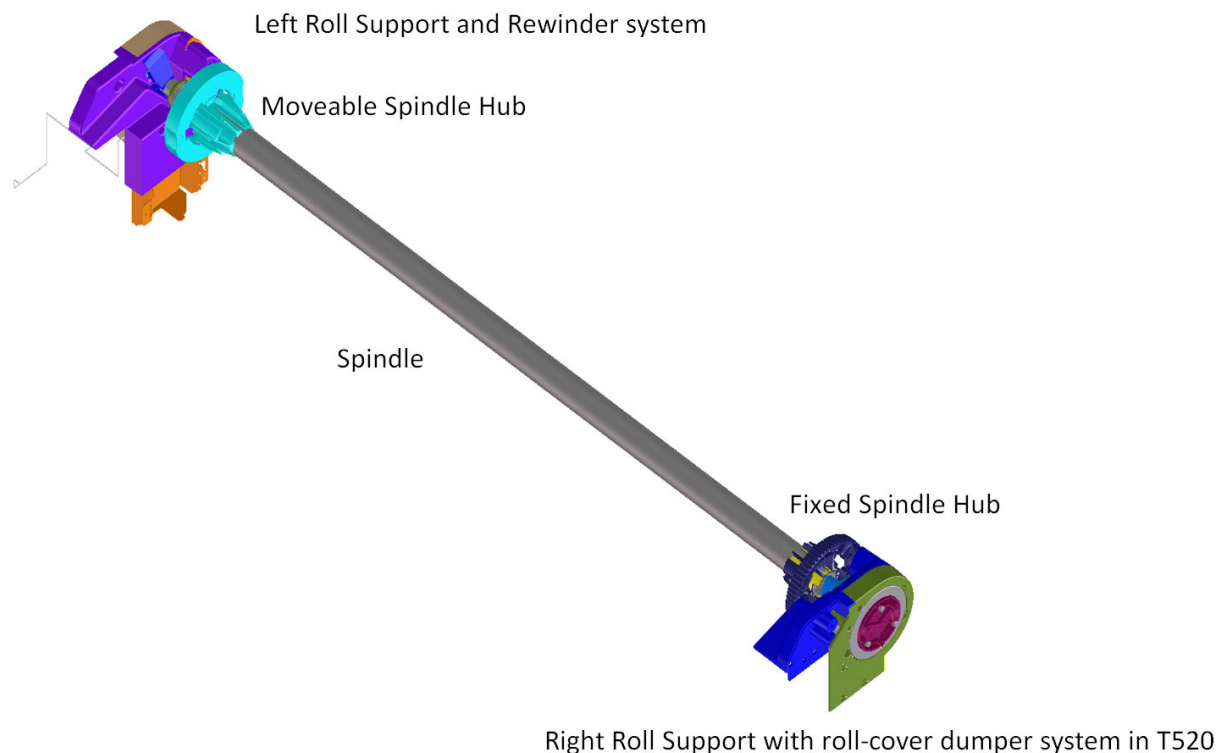

### Electronics

The Rewinder Motor and Encoder system are directly controlled by the Main PCA.

## The paper output system

### Functionality

The system ensures that the printed paper follows a controlled path and acquires a certain shape in order to be delivered properly to the user. It also has a cosmetic function.

The system includes a set of three telescopic trays, which are extended to collect the cut-sheet paper printed from the Multi-Sheet Tray. When printing from roll, telescopic output trays should be closed. Otherwise, Front Panel will warn us.

There are two roll-paper control tabs that are deployed automatically when the telescopic trays of the Output Tray are in the closed position. This is a purely mechanical action as the tabs are pushed up by the output trays when closed. The purpose of those tabs is to control the shape of the roll paper when coming out of the paper path.

The Front Cover is located underneath the Output Platen.

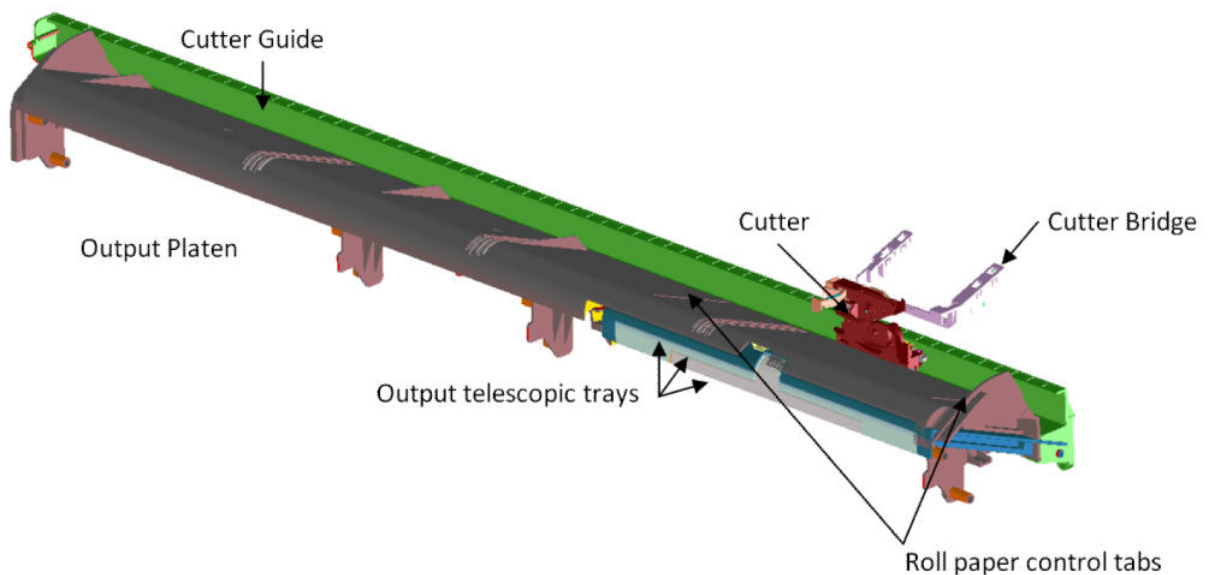

### Electronics

The only electronic component related to the Output Platen is the Output Tray Sensor located underneath the output trays. The sensor is activated when the three output trays are fully closed. The sensor cable is routed via the front of the machine and is directly connected to the main PCA.

### The Cutter system

The Cutter cuts the paper after the print has completed.

It comprises 1) a cutter module that cuts the paper with two rotary blades, 2) a Cutter Bridge attached to the Carriage that catches and releases the Cutter to perform the cutting operation and then to leave it in capping position, 3) a Cutter Guide that holds the movement of the Cutter along the printer width.

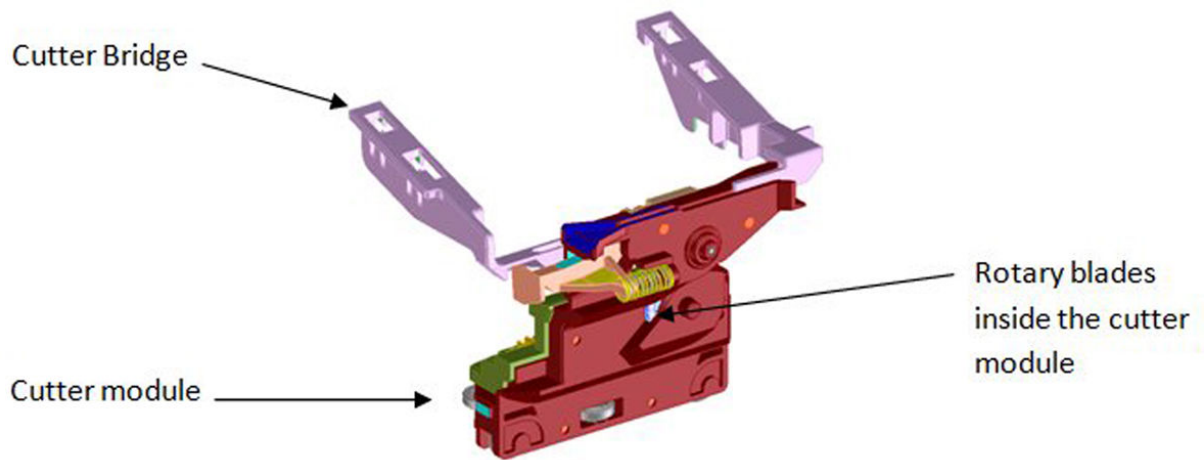

In order to operate the Cutter, it needs to be in the parked position. If not, the Cutter will not be engaged by the Cutter Bridge and the printer will not perform the cutting action.

Whenever the printer initializes, it performs a parking movement with the Carriage to ensure that the Cutter is left in the appropriate position.

The printer does not have any feedback about the cutter engagement action. Hence, if for any reason the engagement is not performed correctly, the printer will continue operating as if the engagement has occurred.

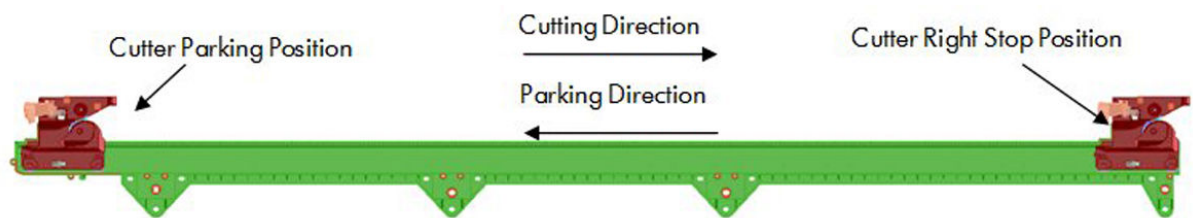

### How activation works

1. Pre-activation phase: The Cutter Engagement Feature of the Bridge gets into the funnel of the Cutter Module grooving the Cutter to ensure the correct position for activation.

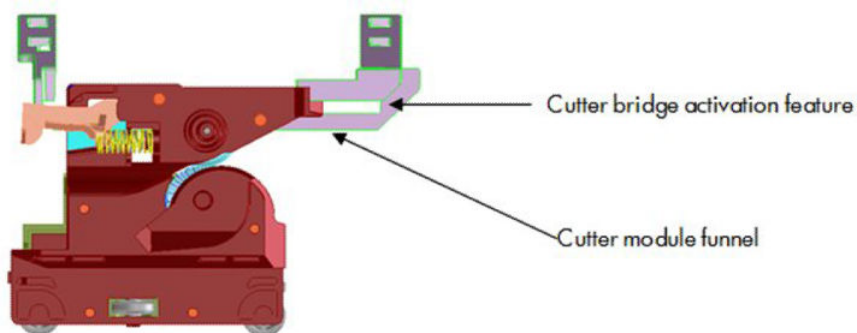

- Hook catching: The cutter bridge continues moving to the left pushing down the cutter hook (in orange), after the left side of the cutter bridge passes the Carriage stops and the cutter hook returns to its position due to its spring motion.

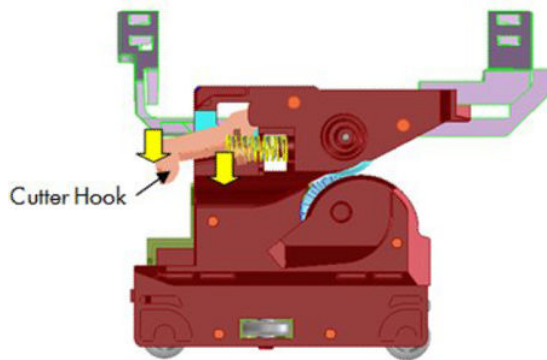

Left feature of the cutter bridge pushes down the cutter hook

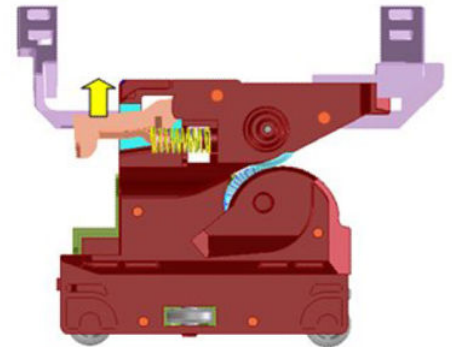

After the cutter bridge left feature passes the cutter hook returns to its position

- Cutter action: The left feature of the cutter bridge pushes the cutter to the left, performing the cutting operation.

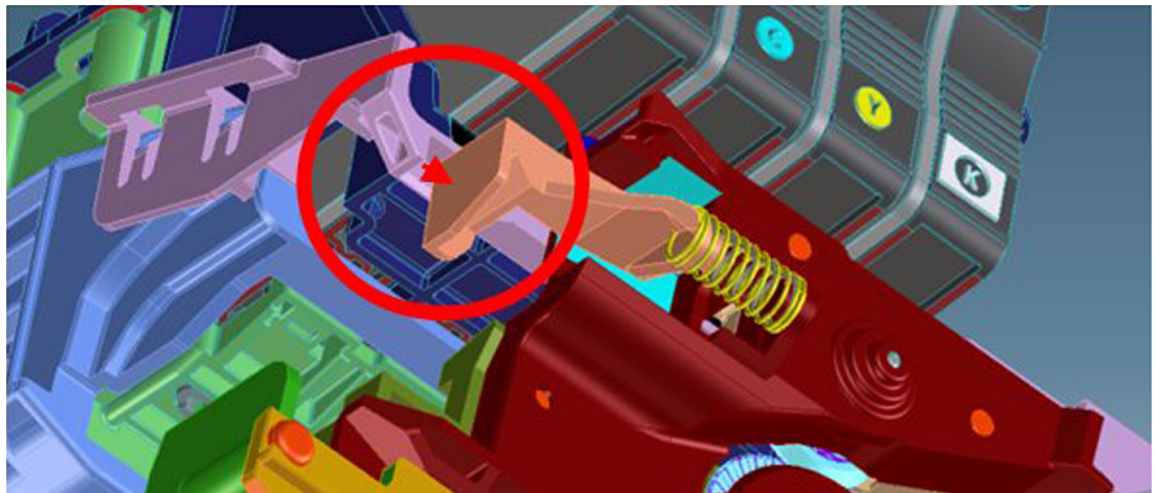

### How deactivation works

- Disengagement: Hook Bridge changes direction moving now from right to the left, so that Cutter Hook slides out of the Cutter Catch Feature.

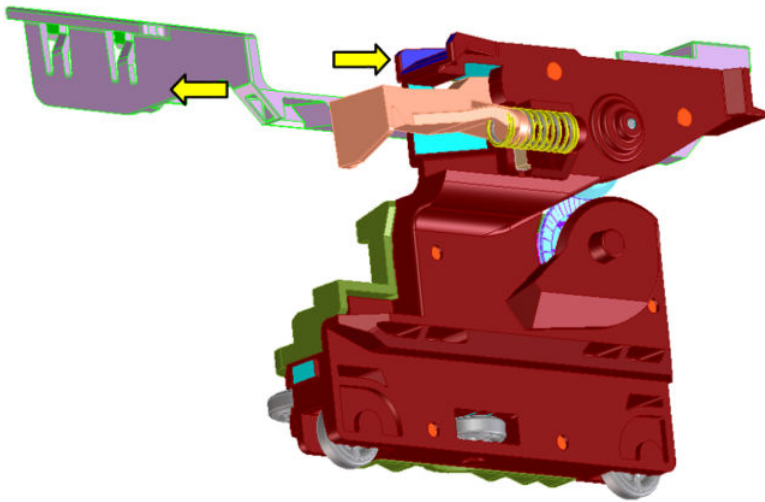

2. Move-away action: the Cutter Hook deactivates from the bridge by passing in front of it.

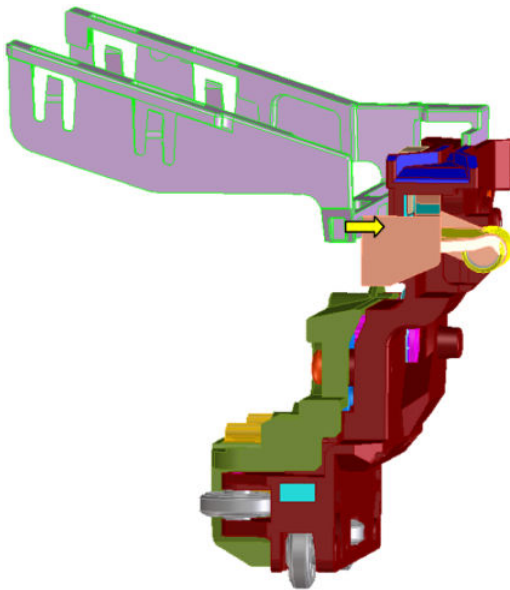

## Accessory tray and right gear module

### Functionality

The accessory tray holds and loads the cut-sheet paper for the printer. The accessory tray itself is a completely mechanical system with no electronics or motors. All the motion drives for both picking and paper drive are or created or transmitted by the Right Gear module located on the right-hand side of the printer, behind the Service Station.

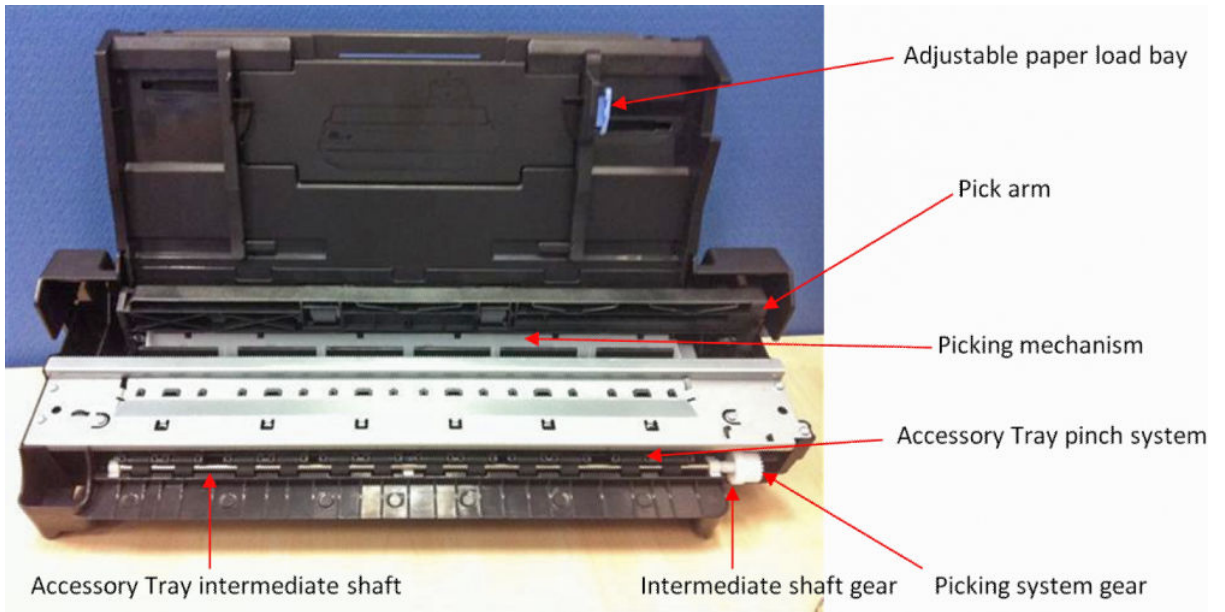

The Right Gear module has two main functions. It contains the motor encoder and gear drive system for the picking mechanism, and it contains the gear train system to transmit the movement from the drive roller to the accessory tray.

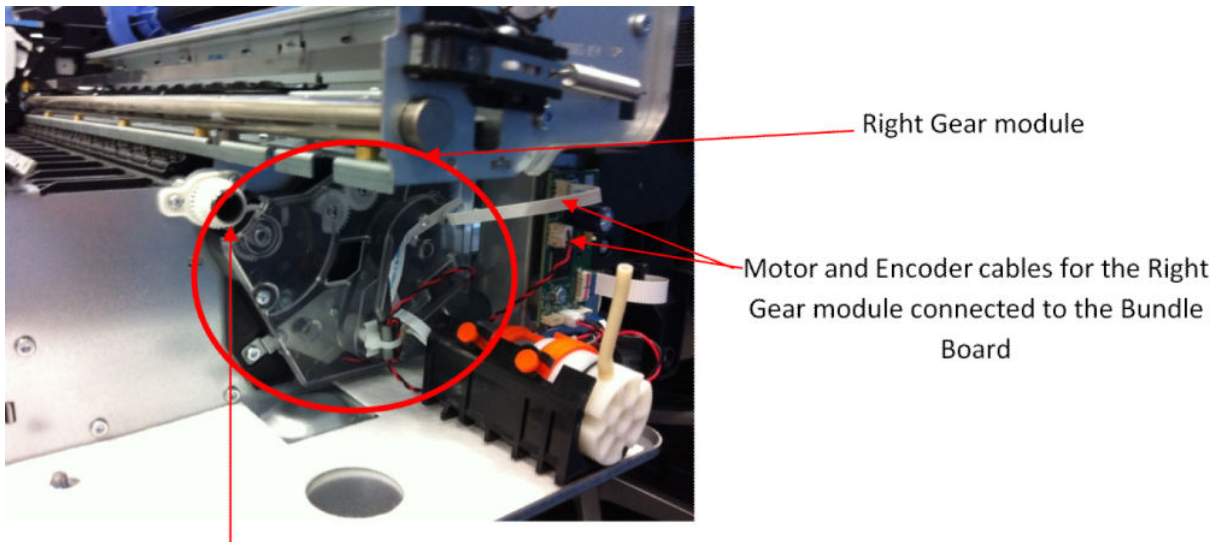

Gear connection between Drive Roller and Right Gear module

### Right Gear module functionality

The Right Gear module has two different functions associated with the Multi-Sheet Tray.

1. The paper drive from the Multi-Sheet Tray into the platen area (until the cut sheet reaches the drive roller area).

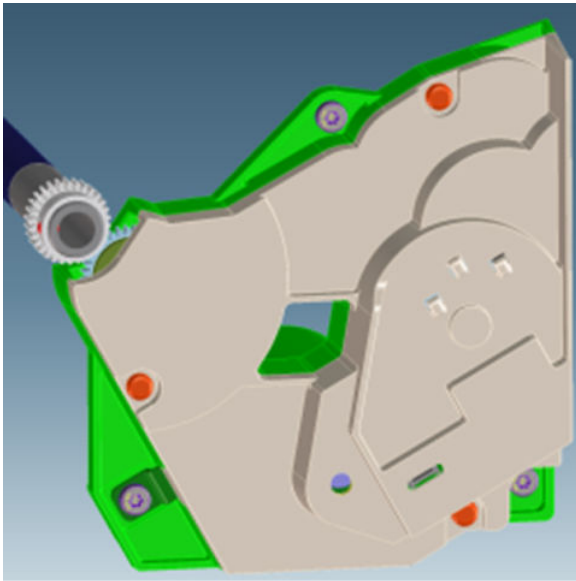

Right Gear module

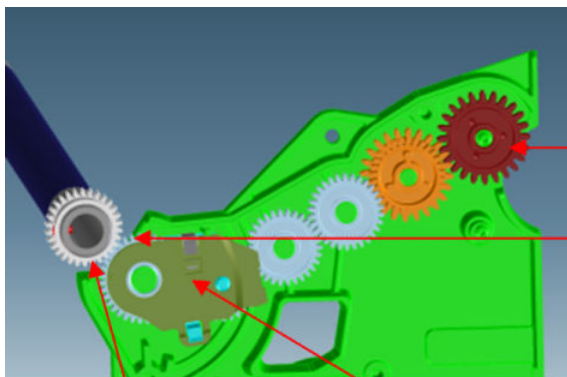

Drive Roller

Swing arm

Accessory tray gear interface

Gear connection between Drive Roller and right gear module

The intermediate shaft in the Multi-Sheet Tray is driven by the drive roller through a gear train inside the Right Gear module. The intermediate shaft meshes with the Multi-Sheet Tray gear interface (red gear in the picture) at the end of the train. A swing arm engages the gear train when the Drive Roller is driven backwards (as shown in the picture), driving the intermediate shaft forwards. When the Drive Roller is driven forwards, the swing arm disengages from the gear train and the intermediate shaft is not driven. This action is to prevent reverse paper movement to be transmitted to the Multi-Sheet Tray.



## 2. Picking functionality drive system

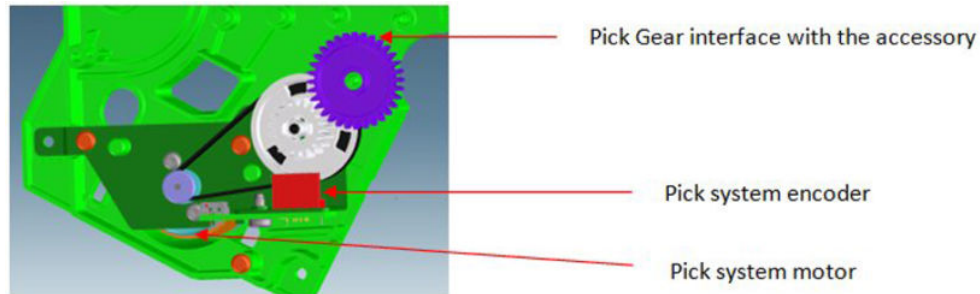

The Multi-Sheet Tray pick drive assembly is mounted in the right side gear module. The assembly contains a DC motor and pinion, belt, cluster pulley, and gear. An encoder (not shown, but it is located in front of the white gear shown in the picture) is read by the encoder sensor (in red in the picture) to servo-control the pick drive.

### Right Gear and Multi-Sheet Tray interface

The two gears from the Right Gear module interface with the Multi-Sheet Tray by location once the Multi-Sheet Tray is locked in position; both gears can be considered fully engaged.

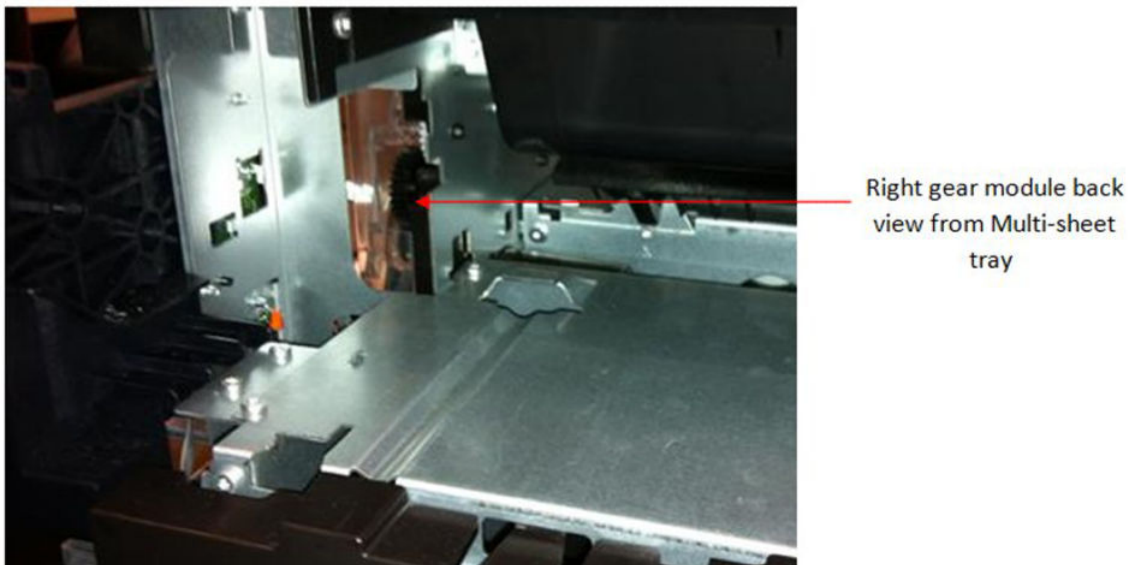

### Multi-Sheet Tray functionality

The function of the Multi-Sheet Tray is to pick and feed the cut-sheet paper until the paper is grabbed by the drive roller (drive roller and pinch system).

The actions performed for those operations are (1) sheet pick and (2) sheet input.

#### 1. Sheet pick

This movement is transmitted through a lateral gear chain in the Multi-Sheet Tray towards the swing arm, which is pushed towards the paper, and the picking mechanism located at the bottom of the Multi-Sheet Tray, which separates the top sheet from the stack of pages.

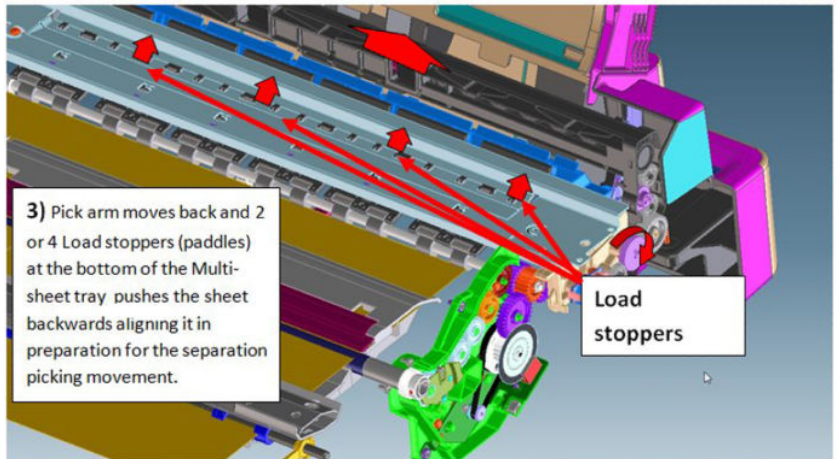
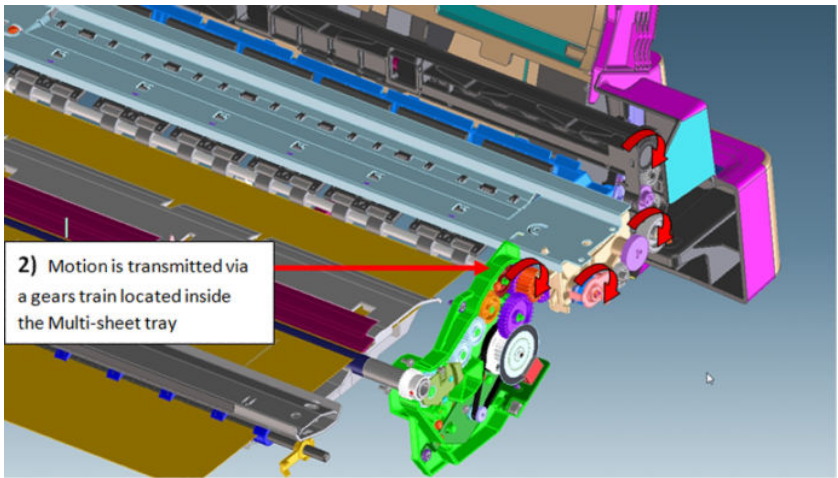
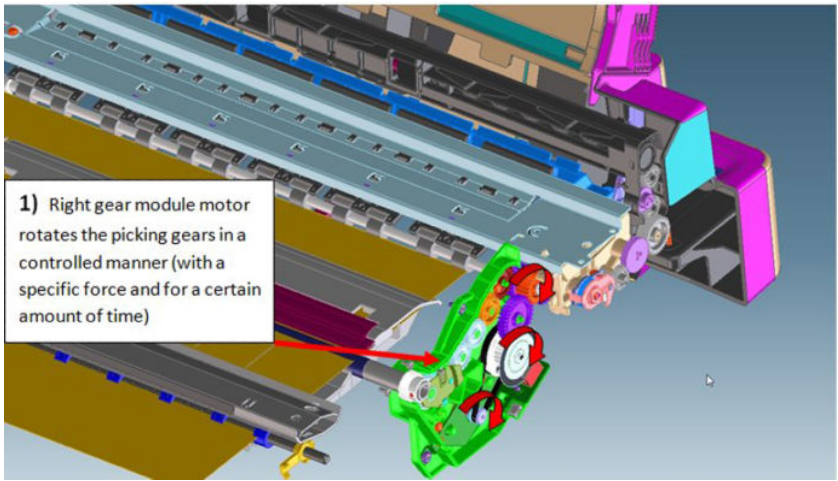

Note: There are 4 load stoppers, the 2 inner ones are used for A4 like size sheets and the 4 of them for A3 size like sheets.

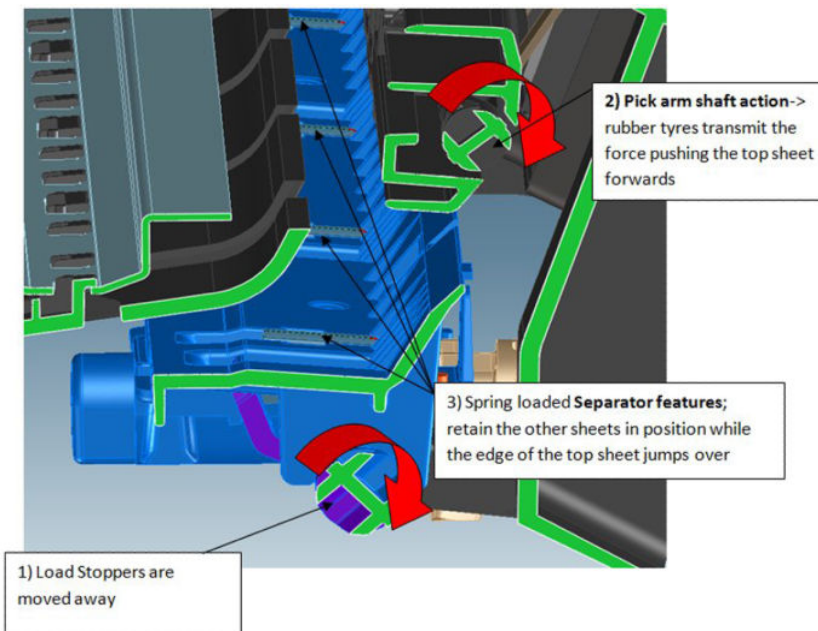
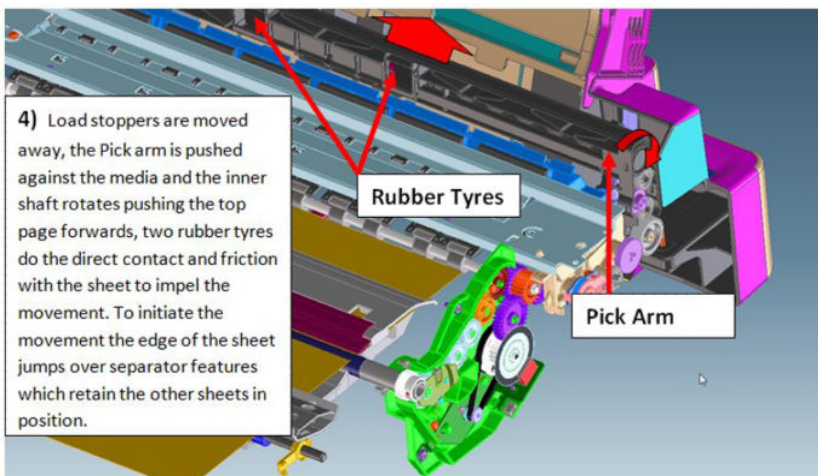
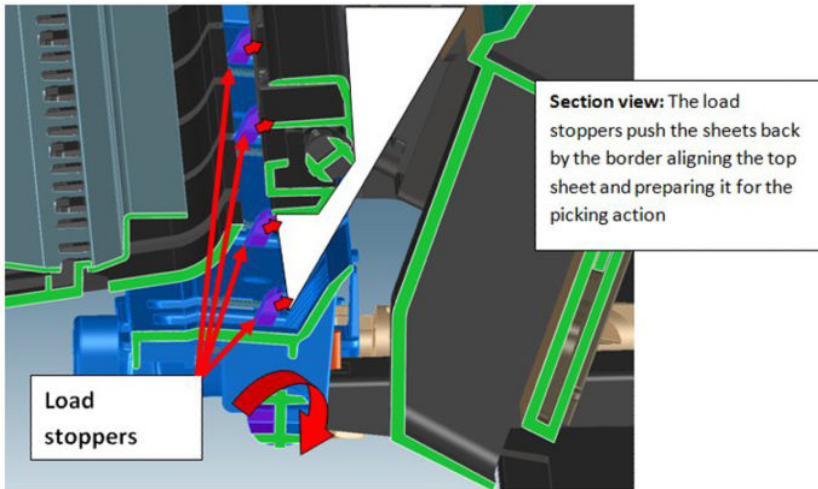

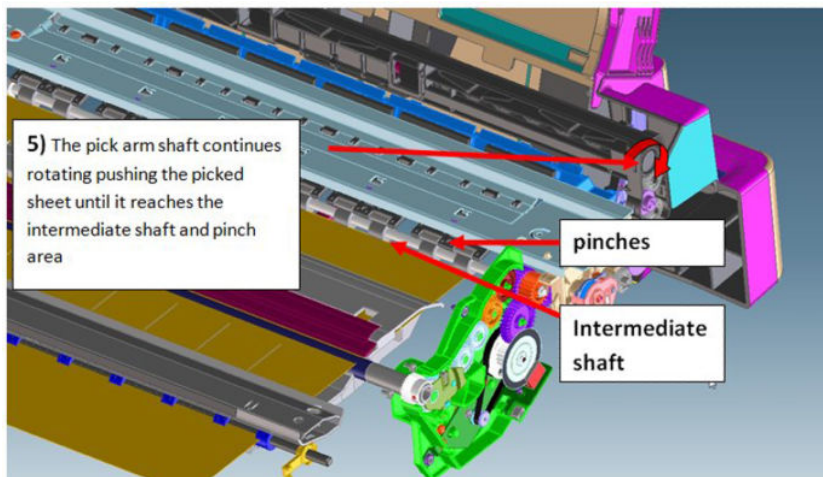



## 2. Sheet input

Once the paper is in the intermediate shaft area, the drive roller is rotated, impelling the intermediate shaft through the right gear module, pushing the sheet towards the inside of the printer, so that it will be grabbed by the drive roller and main printer pinch system, proceeding with the standard paper drive motion (as with roll paper).

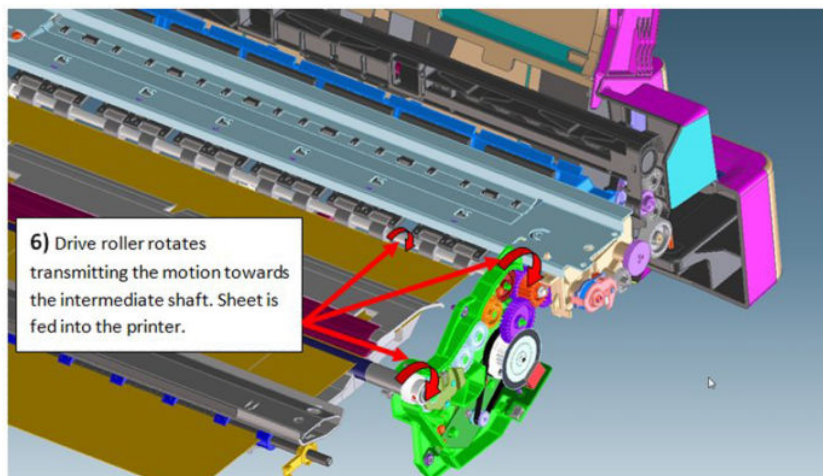
 **NOTE:** The printer considers the load successful if, after the picking and sheet input procedures, the sheet is detected by the printer's Paper Sensor. Hence, a correct function of the Paper Sensor is required also for the accessory tray loading action.



 **NOTE:** It is possible to reproduce the picking and loading motions by extracting the Multi-Sheet Tray and rotating the gears with the hand, to validate module performance and troubleshoot any possible mechanical issues.

 **NOTE:** Different elements of the Multi-Sheet Tray are not serviceable, the whole module requires replacement in case of failure.

## The Multisheet Media Sensor

This sensor detects the presence of media in the Multi-sheet Tray. Media is detected with a retroreflective sensor (known as a Optical sensor) which is mounted on a bracket beneath the media roll. The Optical sensor contains an LED which sends a beam of infrared light towards the Multi-sheet Tray, and an infrared detector which measures how much of that light bounces back to the sensor.

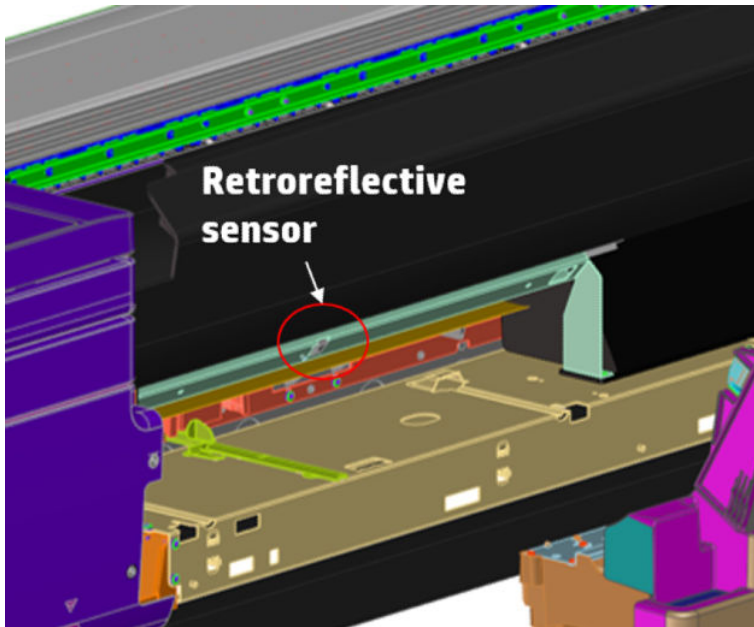

There is also a small mirror, located behind the media on the Multi-sheet Tray separator plate. This arrangement of sensor and mirror is capable of detecting three states:

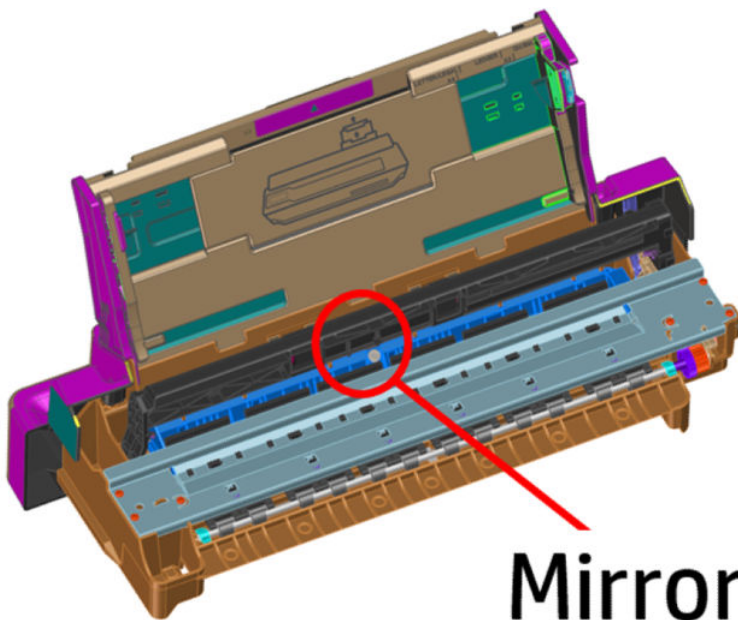

## Mirror

1. When the Multi-sheet Tray is installed but media is not present, the light from the Optical sensor hits the mirror, and almost all of it bounces back to the sensor, resulting in a large signal.

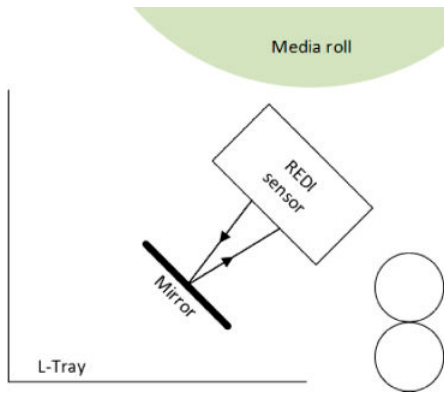

2. When the Multi-sheet Tray is installed and media is present, the light from the Optical sensor hits the media. Only a portion of the light bounces back to the sensor, resulting in a small signal.

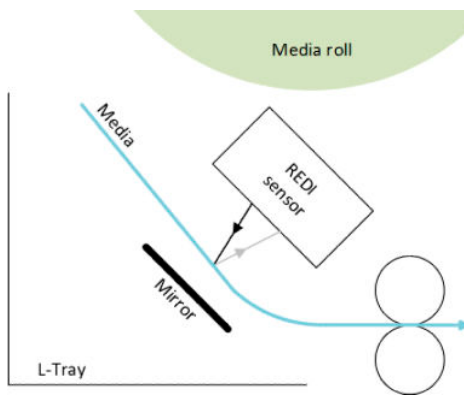

3. When the Multi-sheet Tray is not installed, the light from the Optical sensor does not shine on anything nearby, so no light will reflect back to the sensor, resulting in no signal.

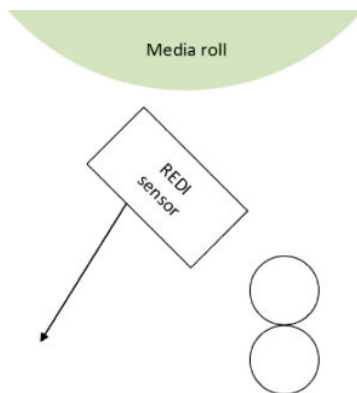

The Multisheet Media Sensor has been designed to be tolerant of the following:

- Assembly variations that affect the position and alignment of the Optical sensor.
- Assembly variations that affect the position and alignment of the mirror.
- Variations in the sensitivity of the Optical sensor.

- Different quantities of media in the Multi-sheet Tray. (A taller stack of sheets will reflect a little more light back to the sensor).
- Different media types, including off-white and glossy media.

The Multi-sheet Media Sensor may have problems in detecting certain media types:

- Transparent.
- Dark-colored paper.

## Electronics

Both the encoder and motor-drive system are managed by the Printer Bundle Board located on the right-hand side of the printer.

## Scan Axis system: Carriage and Carriage impelling

This system moves the Carriage from left to right and right to left of the printer on top of the paper in a controlled manner to perform printing, cutting, paper detection, and any other Carriage movements for servicing and final capping process.

The system comprises the Carriage sliding on the scan axis rod, on which rotates and whose position is determined by a cam mounted on the Carriage, which slides touching the bottom surface of the anti-rotation rail.

There are two trailing cables mounted one on top of the other, which connect the Carriage with the main electronics control board. A scan-axis encoder strip is needed for the Carriage to determine its position, and a Carriage Motor which impels the Carriage via a belt.

The trailing cable is held in position by a plastic holder, which clips onto the scan axis structure. A spring-loaded loop ensures follow-up action of the cables with the Carriage movement. Two plastic cable sliders are also placed to ensure minimum contact of the trailing cables with the scan axis structure. The plastic sliders are greased to prevent ink spray (aerosol) deposits from accumulating on them, generating a sticky surface which could retain the cables and then be damaged by Carriage movement.

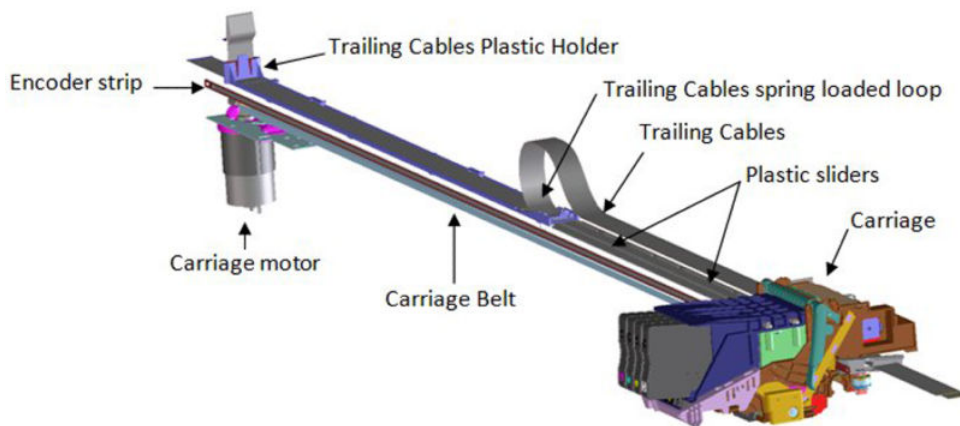

Greased cable sliders (2 in the 24" machine and 3 in the 36")

The Encoder Strip Sensor is located inside the Carriage, once the Carriage is assembled the Encoder Strip crosses the Carriage, passing by the detection area of the sensor inside the Carriage.

The main function of the Carriage is to hold the printhead in position and to move the printhead in a controlled manner in order to print.

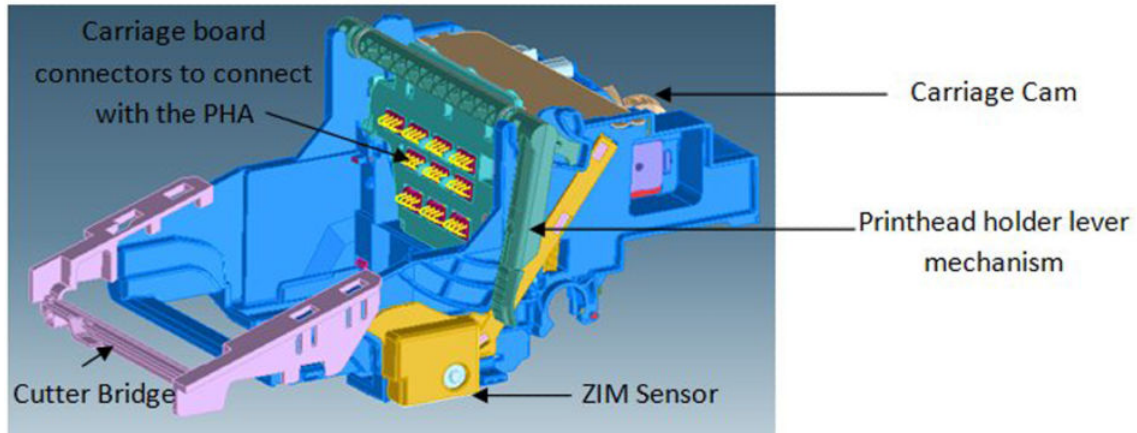

The Carriage holds all the necessary interface electronics for the main board to interact with the printhead via the trailing cables. A set of spring-loaded connectors are the main interface Carriage-printhead.

**NOTE:** It is very important that the contacts are clean, free of dust/ink to ensure a correct connection between printhead and Carriage, as high-speed data are transmitted through this connection, and dust could cause sporadic system errors. This is particularly important when replacing the printhead, as the removal of the old printhead (extraction with a rotary movement) can cause the nozzle plate to touch those contacts and create contamination that could cause problems with the new printhead. However, manual cleaning of the contacts is not recommended.

The Carriage also has additional functionality:

1. Transmits the pressure from the Prime Pump via off-axis coupling to each of the four cartridges
  - Off-axis coupling connects with the Carriage via the side connection bay:



- An internal passage of the Carriage transmits the air pressure towards the printhead.



- The rear hole of the printhead receives the air pressure which is distributed towards the four air ports inside the printhead.

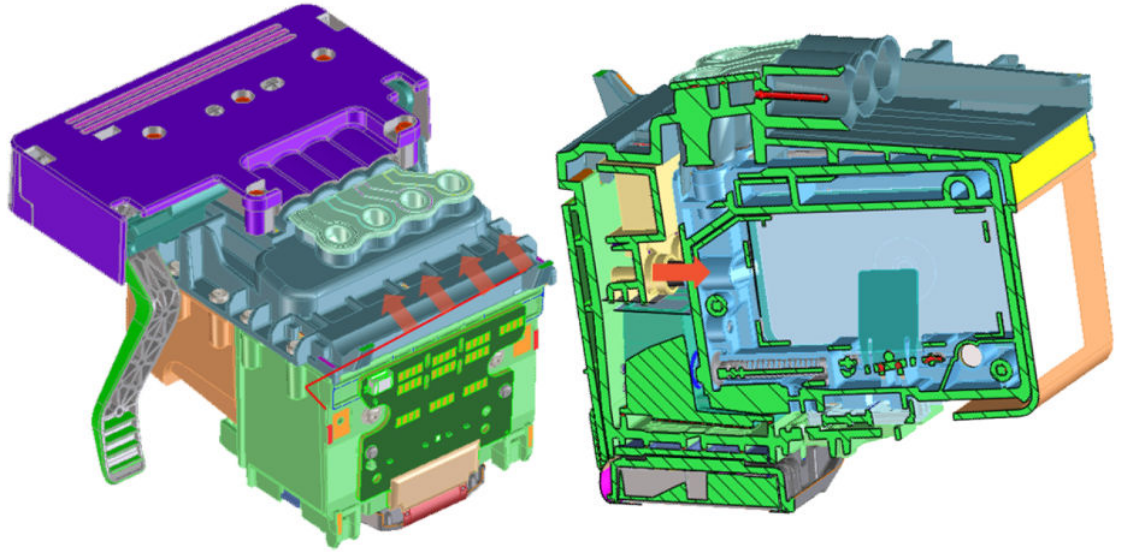

**2.** Holds the cutter bridge

The cutter bridge impels the Cutter for cutter operations (see additional information in the cutter section).

### 3. Holds the Carriage Line Sensor

The Carriage Line Sensor (also known as the ZIM Sensor) is located on the right of the printer and is used to detect the edges of the paper to determine the paper dimensions and start position. This sensor is also the tool used to detect the position of printed lines to perform calibrations (Paper Advance calibration and printhead alignment).

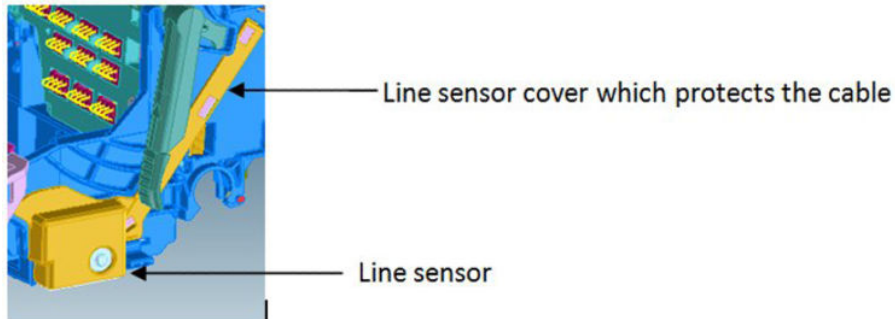

The Line Sensor is a reflective tool that generates a beam of LED light, whose reflection is detected by a luminance sensor. The signal from this sensor is used to determine the position of lines or paper edge according to the position of the Carriage.

**NOTE:** Both LED emitter and receiver sensor inside the line sensor are protected by a transparent plastic cover. If this cover becomes dirty, the signal to detect edges or lines will be affected, which could cause intermittent issues during the paper load.

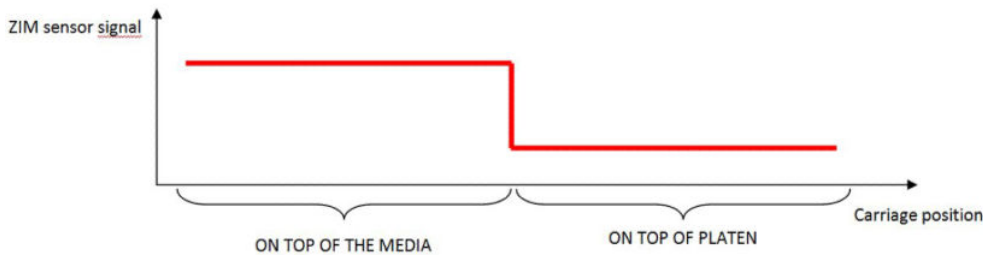
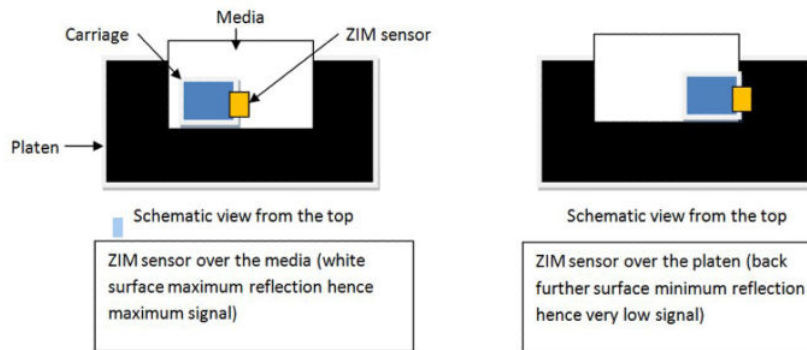

It can also detect printed lines from short signals when the sensor crosses the lines:

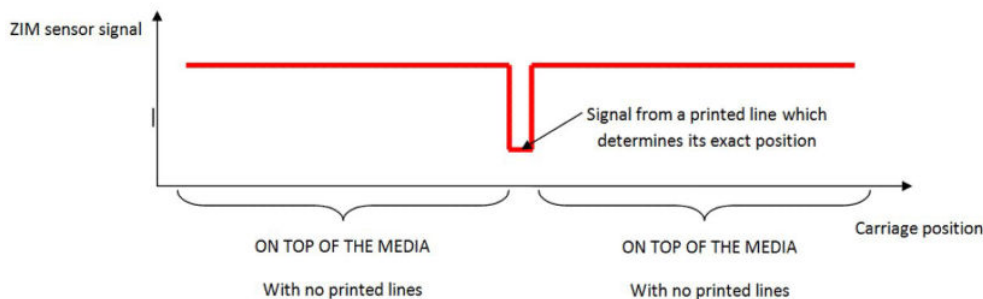

## Carriage CAM and Auto PPS adjustment

At the back of the Carriage there is a sliding cam that determines the PRS (Print to platen Rib Space) of the Carriage. In manufacturing, the anti-rotation rail (area in which the PRS cam slides) is adjusted to calibrate the nozzle plate position of the printhead, at around 1.6 mm all along the scan axis width. This calibration is not service-adjustable and should remain constant throughout the printer's life.

As there are different paper thicknesses, the printer is able to rotate this sliding cam automatically to three different positions, changing the PRS distance to accommodate it to the appropriate printing distance.

This rotation is performed by taking the Carriage to a feature on the left-hand side of the scan axis, different side movements of the Carriage at different speeds allow this feature to grab and rotate the cam accordingly. The Cam has three different areas for three different PRS adjustments.

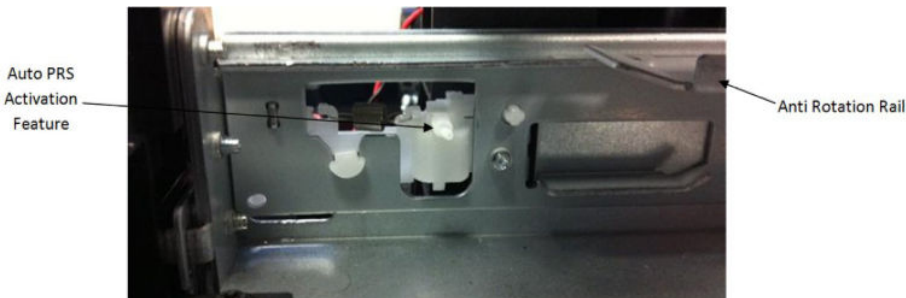

Auto-PRS feature located on the left-hand side of the scan axis.

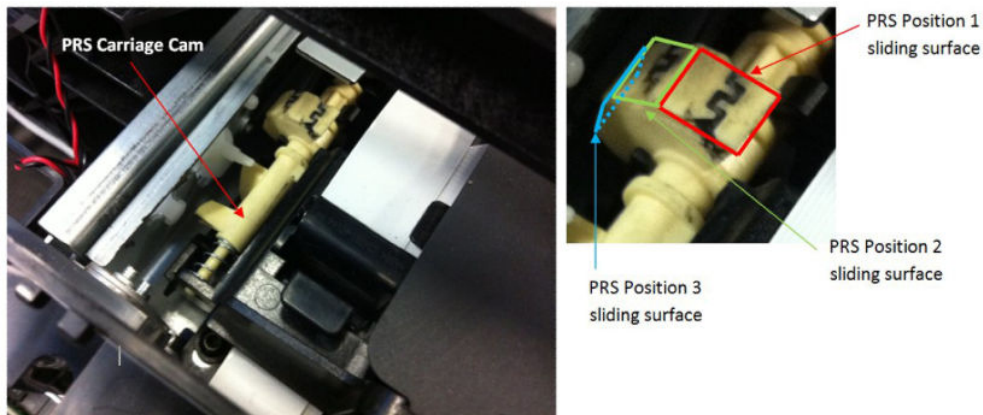

Back part of the Carriage with auto-PPS cam, after being activated in position 1.

## Carriage impelling system



### Carriage motor tensing system

- 1) Motor is assembled on holder which slides on the scan axis chassis
- 1) Belt tensing spring keeps the belt tension pulling from the motor holder

Carriage motor holder

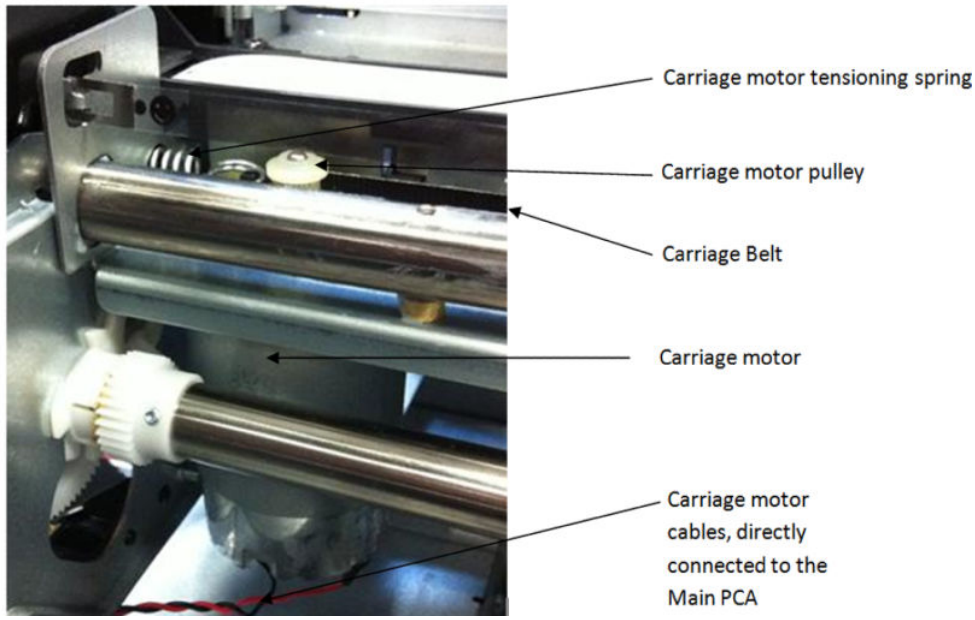

### Carriage encoder system

The encoder strip tension is also fixed by a tensioning spring. However, there is a mechanism to hold it in position after the spring places the strip at one specific tension. This is to prevent the spring from continually applying force over the encoder strip; which, over time and temperature changes, could make it creep.

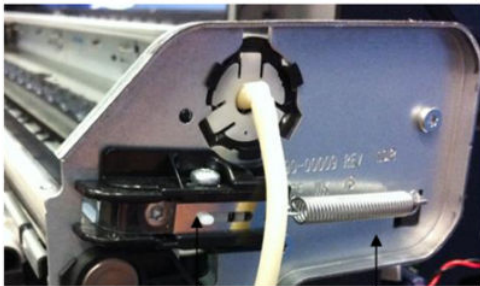

Encoder strip locking device

Encoder strip tensioning spring

Encoder strip tensioning system.

- 2) Encoder strip is tensioned by the spring force
- 3) After the encoder strip tension is set by the spring, it is then possible to lock the encoder position by the locking feature placed on the right plate of the scan axis to prevent long term creep created by the constant spring force



**NOTE:** When assembling the encoder strip, ensure that it is placed in the right orientation using the smiling symbol located on the sides of the encoder strip.



 **NOTE:** Due to the proximity of the encoder strip to the greased sliding rod, it is easy to dirty the strip with grease when performing any repair operation in the area. Please clean any grease from the encoder strip if necessary. A dry cloth can be used for this purpose, to prevent any deformation or strain on the encoder strip while performing the cleaning.

## Printer electronics, power supply, and cables

The printer contains several electronics boards and electrical and electronic components in different locations.

- There are three main active boards (Main PCA, Printer Bundle Board, and MFP only; Scanner Bundle Board).
- One WiFi Module, which provides the WiFi functionality to the printer.
- One interface board (Carriage PCA), which provides and converts the appropriate signals for the Carriage (printhead interface and line sensor signaling) .
- Five on/off sensor PCAs (Central Window[SFP]/Front Window[MFP], Out of Paper Sensor, Output Tray Sensor, Ink Door sensor and PHA Door sensor).
- One NVM Back up memory PCA for storing all factory calibration values.
- One encoder sensor and a feed index sensor (other than the encoder sensors located inside the Rewinder, the Right Gear Module, and the Service Station).
- One Power Button PCA. Located in the front panel, it is used to power the printer on and off.
- One Power Supply (PSU), which converts the AC power line (110–240 V AC) into the DC power needed by the printer (32 V and 12 V).

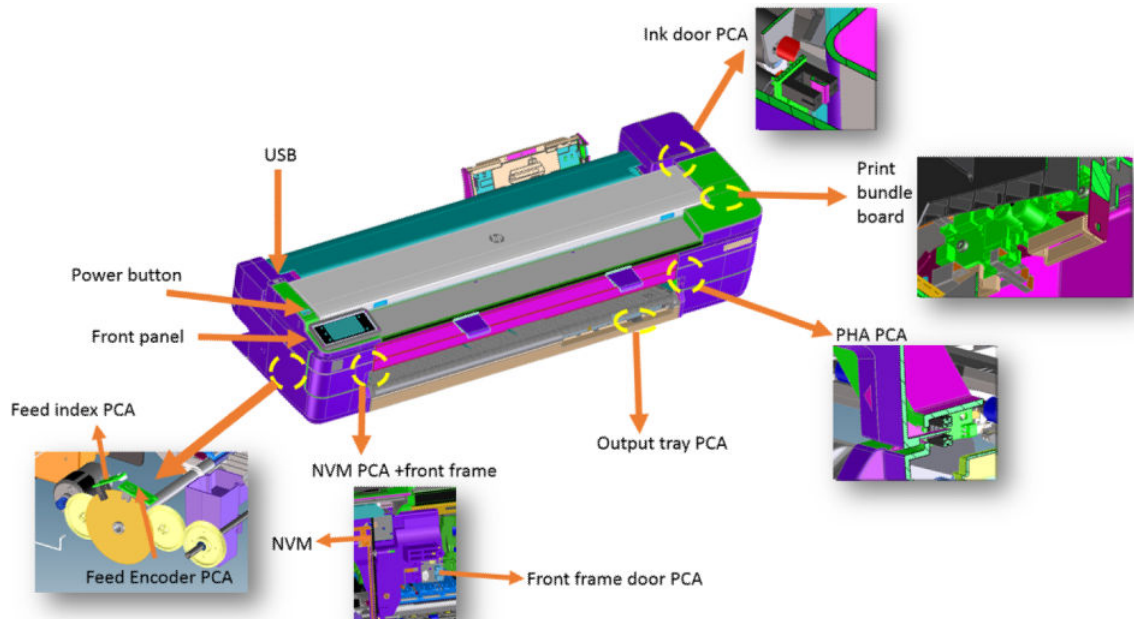

The standard wiring used in the printer is Flat Flexible Cables (FFCs), to interconnect all boards (including sensors and encoders) and distributed cables for power signals to the motors.

**NOTE:** It is important to bear in mind that FFCs are relatively delicate, so please ensure cable connectors are not touched or dirtied during manipulation for assembly and disassembly operations.

**NOTE:** Ensure that you are properly grounded for any electronics or wiring manipulation.

## The Main PCA

The Main PCA is located on the left-hand side of the printer. This board is the “brain” of the printer: where all the processing and printer management occurs; control of the overall machine (digital and mechatronics) with the battery for the Real-Time Clock. Single function and Multifunction versions share the same Main PCA. Memory size is 1 GB.

The Main PCA also contains other elements with the following functions:

- **Battery:** To maintain the internal clock running. The internal clock is used to remember the actual date, used for cartridge life counting and warranty accounting.
- **WiFi module:** Attached to the top of the board with some plastic locators, provides WiFi functionality to the printer.
- **Buzzer:** To provide acoustic signals to the user.

Front:

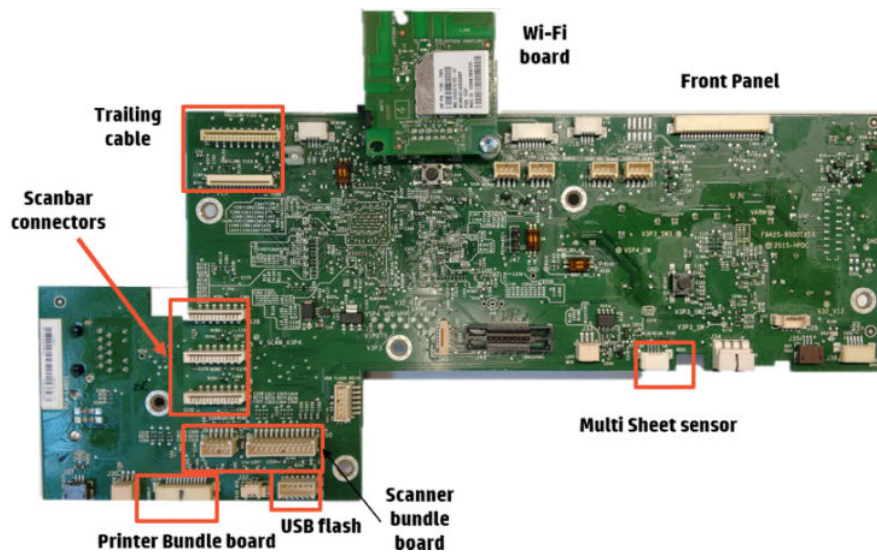

Back:

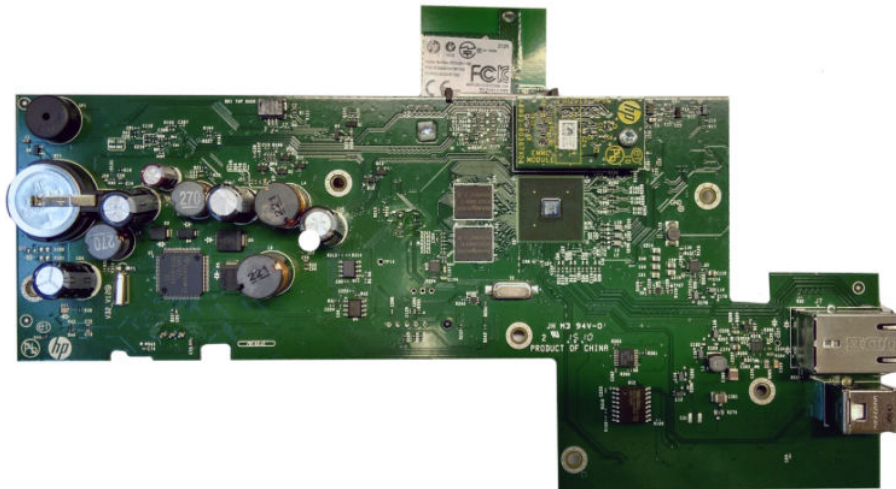

### The Printer Bundle Board

The Bundle Board is located on the right-hand side of the printer, this board includes a driver ASIC to control and manage the motor, encoder, and sensors located on the right-hand side of the printer.

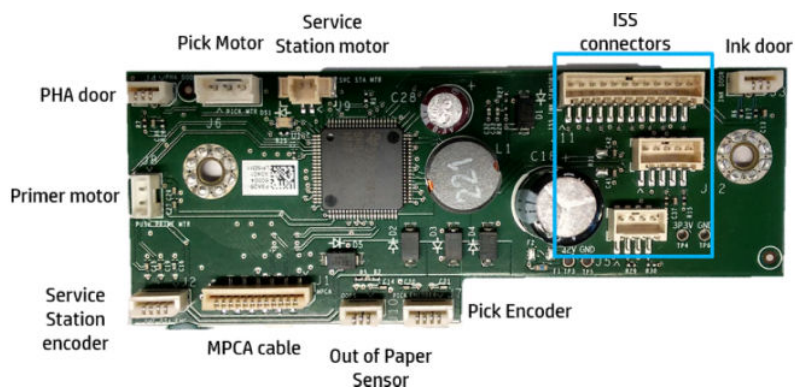

**IMPORTANT:** The pick encoder and Service Station cables are not poka-yoke cables: it is possible to connect them incorrectly, in which case a system error will result.

### The Scanner Bundle Board (HP DesignJet T830 MFP only)

The Scanner Bundle board is located inside the scanner. It manages scanner sensors and the scanner motor and acts as back up memory for scanner calibrations.

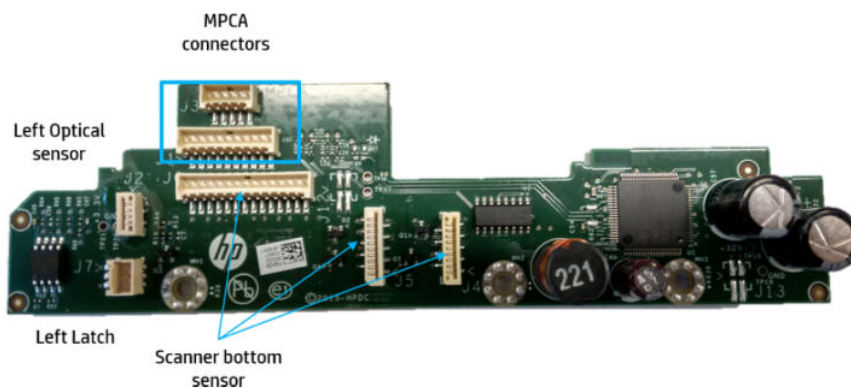

## Electrical system

The following diagram describes the connections between components and electronic boards, the voltage, and the type of data line.



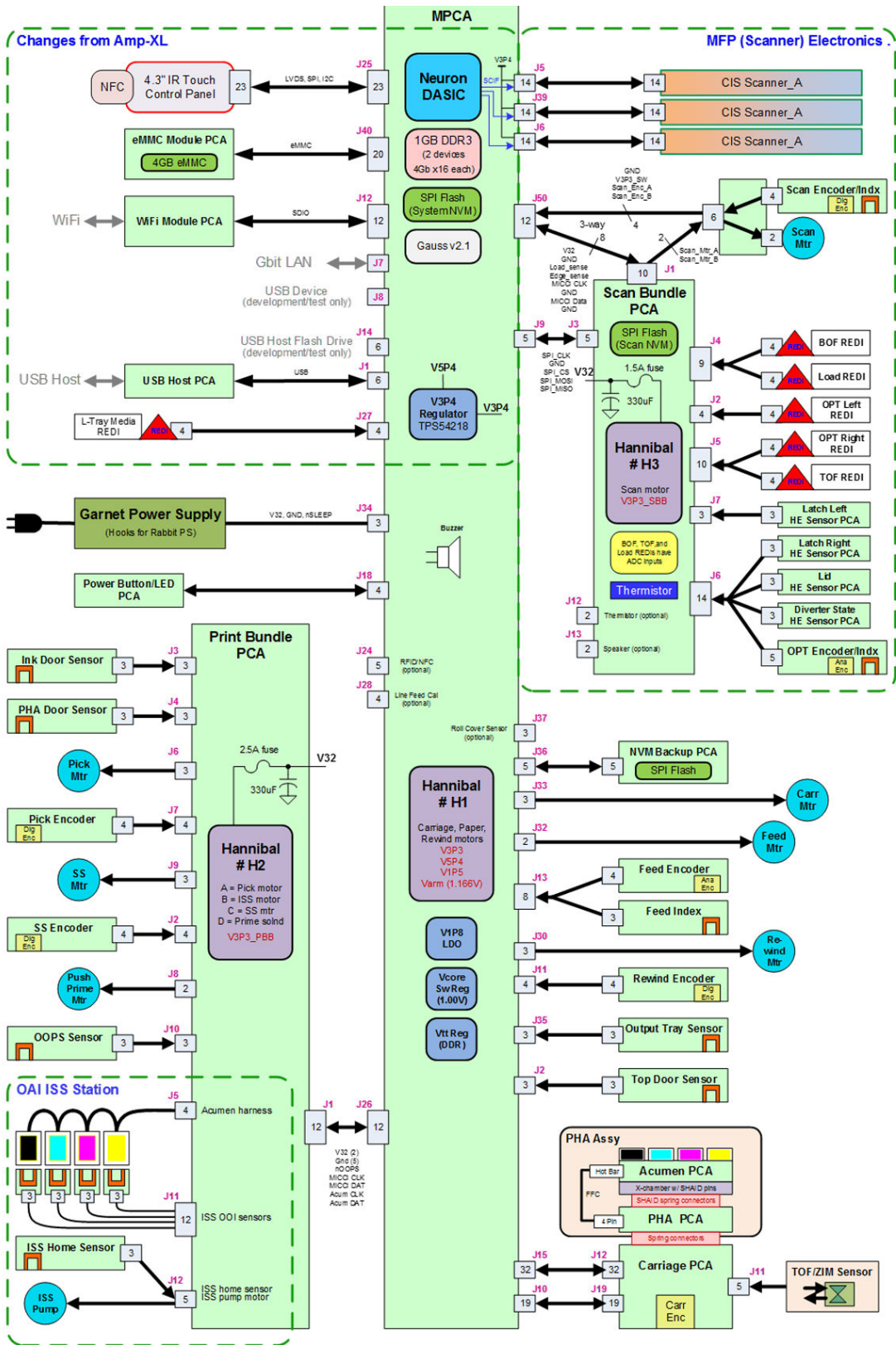

- The printer contains a total of 21 PCAs in the SFP and 29 in the MFP. All sensors and encoders are on PCAs; see the system block diagram (light green blocks represent PCAs).
- The OOP sensor, Top Cover, and Feed Index are exactly the same board.

- The WiFi PCA, although included in the Main PCA Service Kit, is a different board used in other products.

<b>Part</b>	<b>Brief technical function</b>
Main PCA	Contains memory and Firmware, manages paper and carriage motors
Bundle Board	Mechatronics driver for the right part of the machine motors and encoder
Front panel and power button	Tactile color visual screen with buzzer for machine power up and down, control, and user interface
Ink Door Sensor	Ink Door Sensor opening state control
Carriage PCA => Part of Carriage assembly	Carriage control and feed for printhead spitting
OOPS	Paper presence detection
Output Tray sensor	Front tray state control (open or closed)
Front Frame (HP DesignJet T830 MFP)/Top Cover sensor (HP DesignJet T730 Printer)	Front Frame (HP DesignJet T830 MFP)/Top Cover (HP DesignJet T730 Printer) state control (open or closed)
Feed index	Encoder to detect the paper placement (absolute)
Feed encoder	Encoder to control the exact advance of the paper (relative)
Wifi PCA	Radio module (including antenna) to give wireless capabilities (802.11 b/g)

## Locations of the PCAs

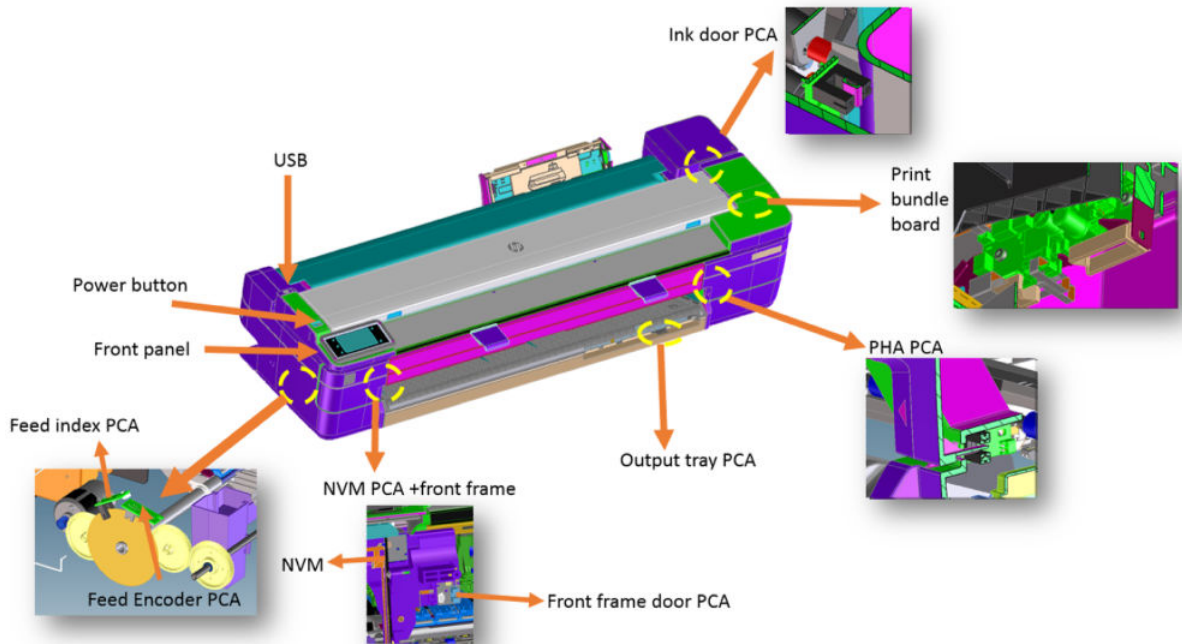
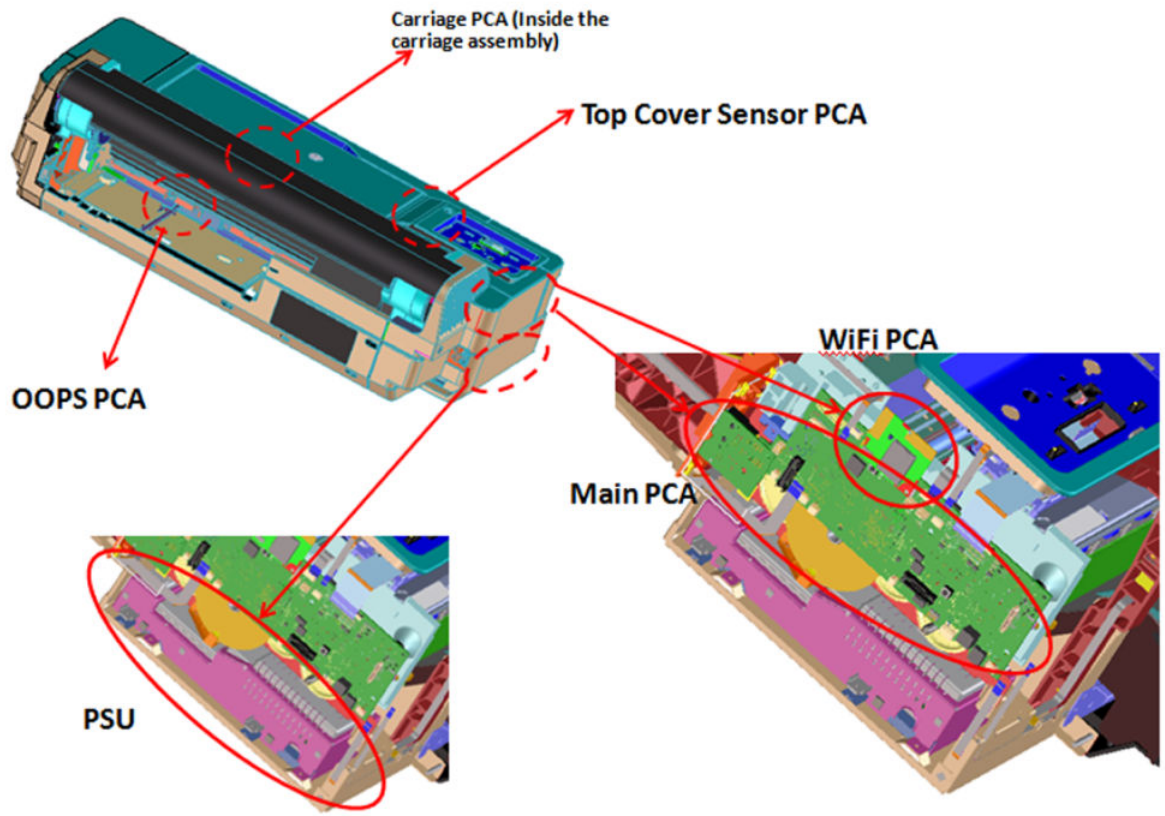

## Stand Description

The stand Supports the unit during use and has a bin to collect print outs from the machine.

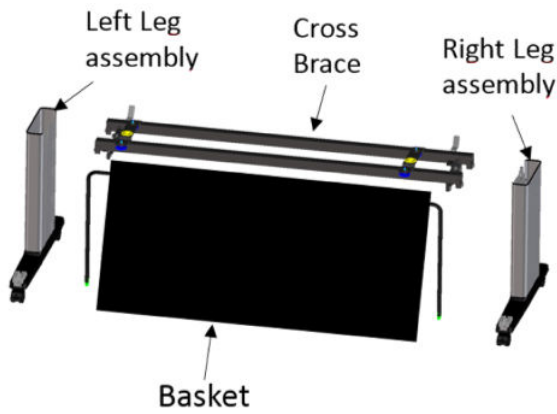

In order to make the assembly easier the stand has poka yoke features (yellow caps), and some guiding features:

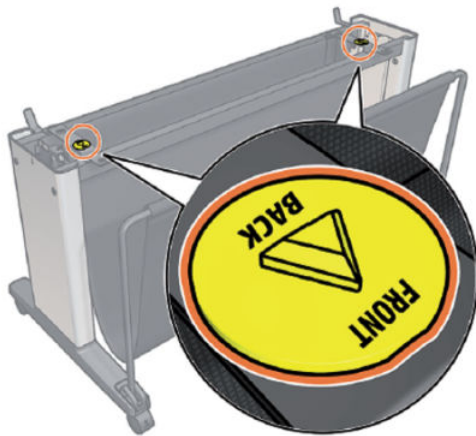
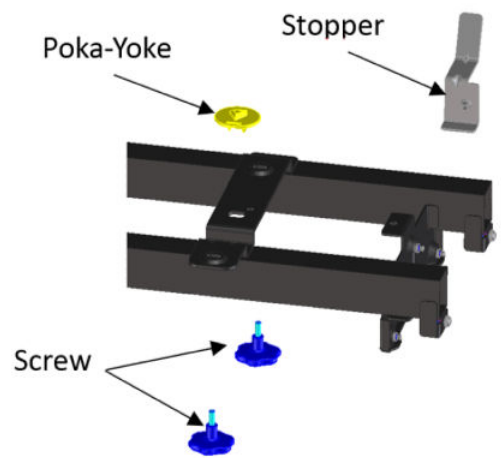
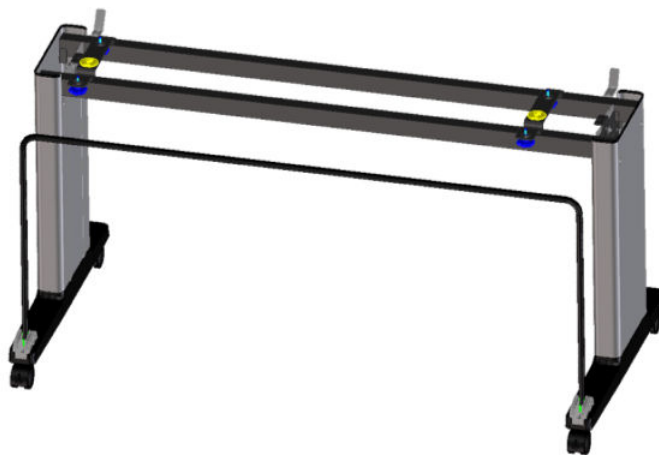

## Scanner

### Overview

The HP DesignJet T830 MFP scanner is an automatic document feeder scanner placed on top of the printer. The main elements are:

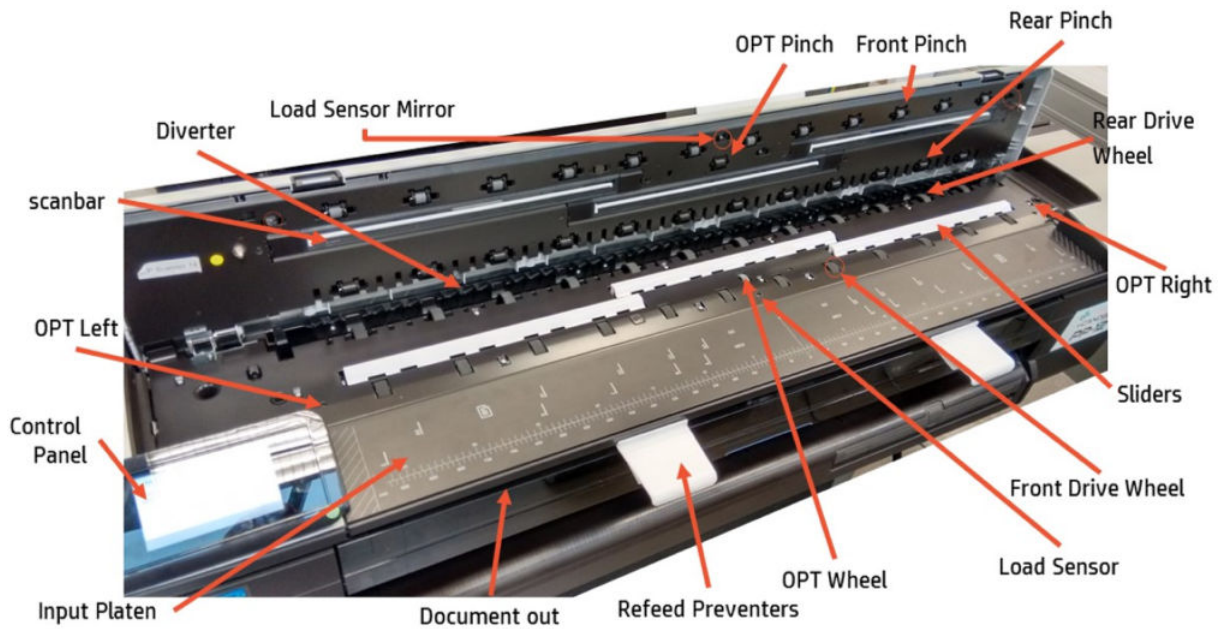

### Integration with the printer

The scanner is attached to the printer with 4 screws. Assembly is from top down, but it is necessary to slide it to the left slightly to ensure that the tabs for the screws on the right on are not damaged. For this reason there are guides on the left arch:

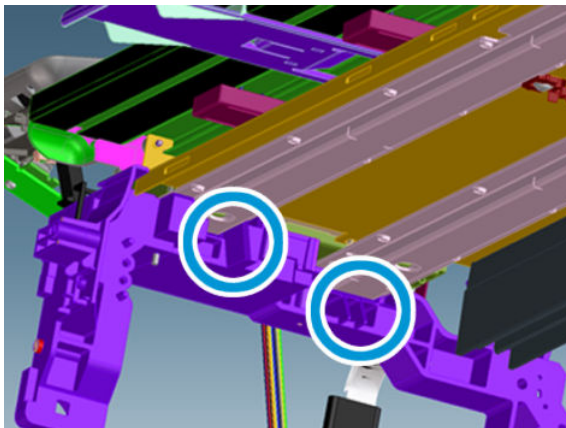

Location of the screws:

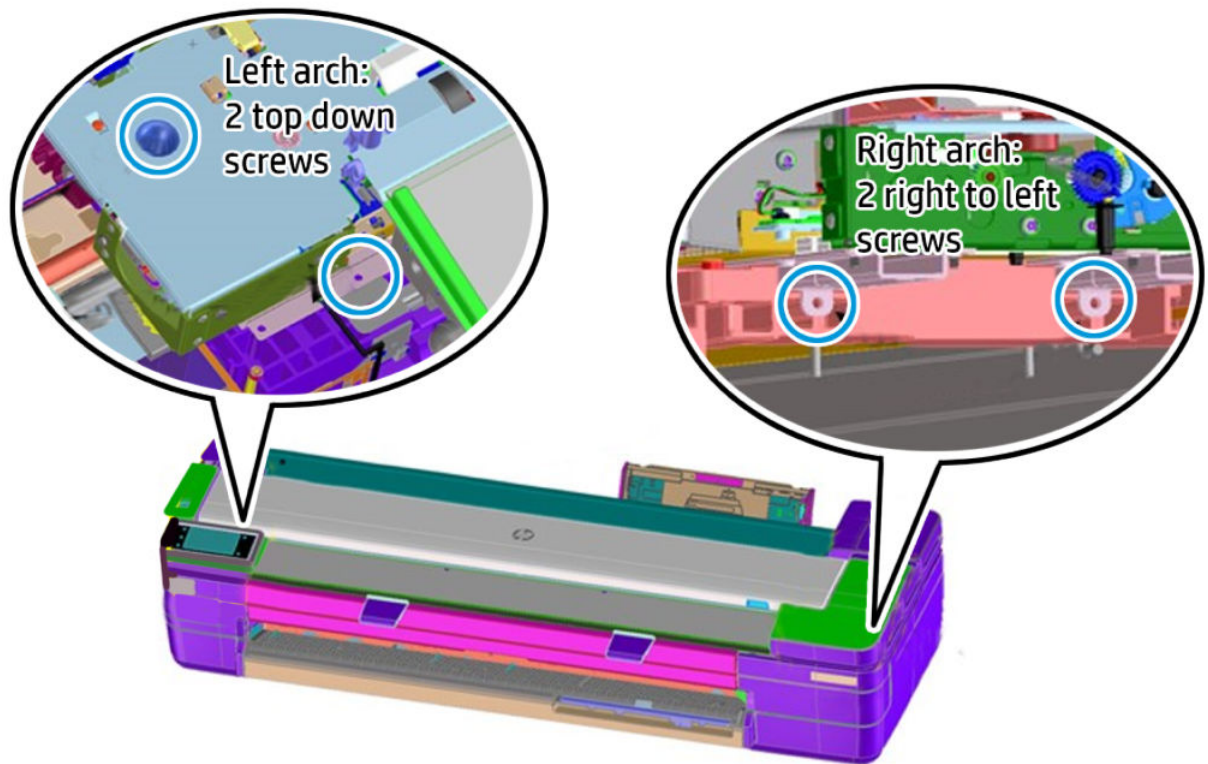

### Front panel outboard position

The front Panel and power button assembly are temporarily placed out of position to protect them when installing the scanner.

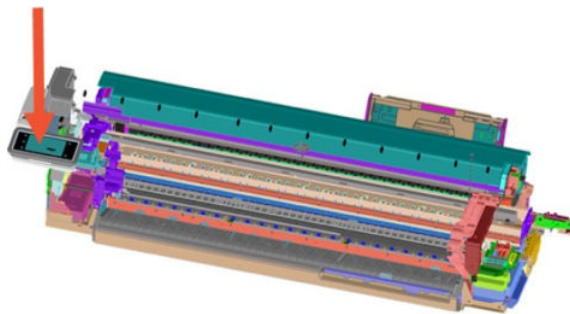

The front panel fits into a pin and box to help secure it:



- ▲ Place the long screw boss of the front panel sub-assembly into the pocket and press it down until it sits in the bottom.

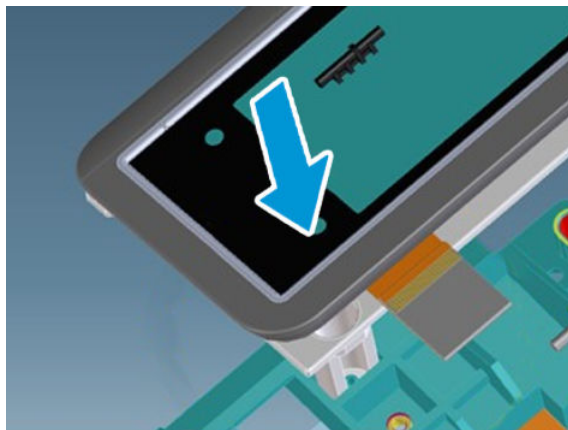

## EE layout

Scanner general electronics layout:

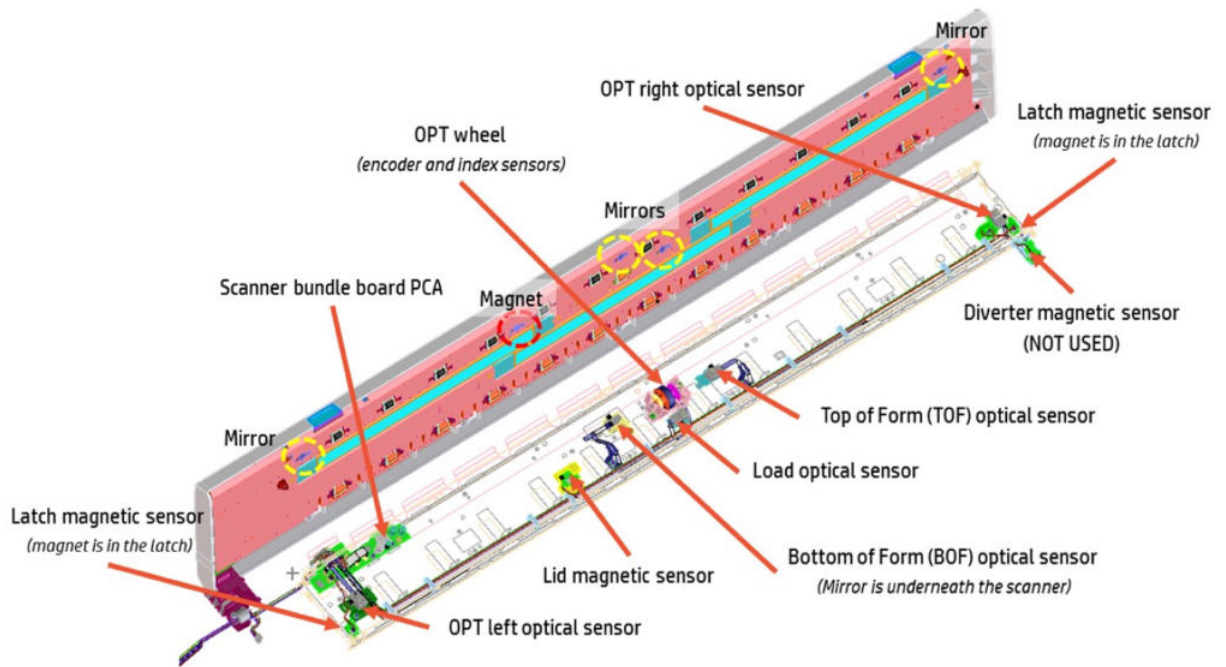

## Sensor principles

The scanner has two types of sensor:

- Mirror Sensor (Optical):** The Optical sensor contains an LED that sends a beam of infrared light towards the Multi-Sheet Tray, and an infrared detector which measures how much of that light bounces back to the sensor:

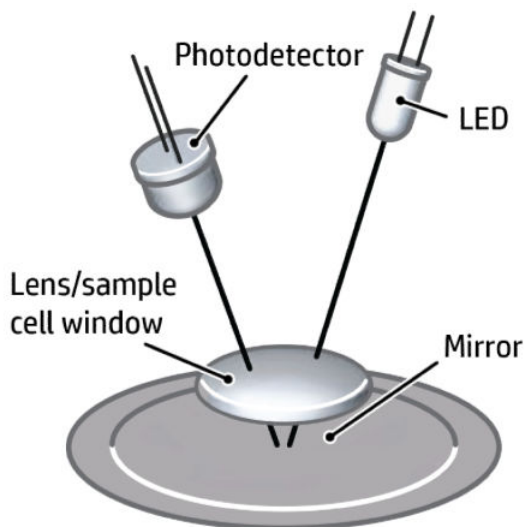

- Magnetic sensor (Lid magnetic):** This sensor is based on the Lid magnetic. When a magnet approaches the sensor, a current is induced in the sensor and it can be used as a detector.

## CIS scanning technology

Contact Image Sensors (CIS) are image sensors used in flatbed scanners in direct contact with the object to be scanned. A CIS typically consists of a linear array of detectors, covered by a glass, and flanked by red, green,



and blue LEDs for illumination. The use of LEDs allows the CIS to be highly power efficient, allowing scanners to be powered through the minimal line voltage supplied via a USB connection.

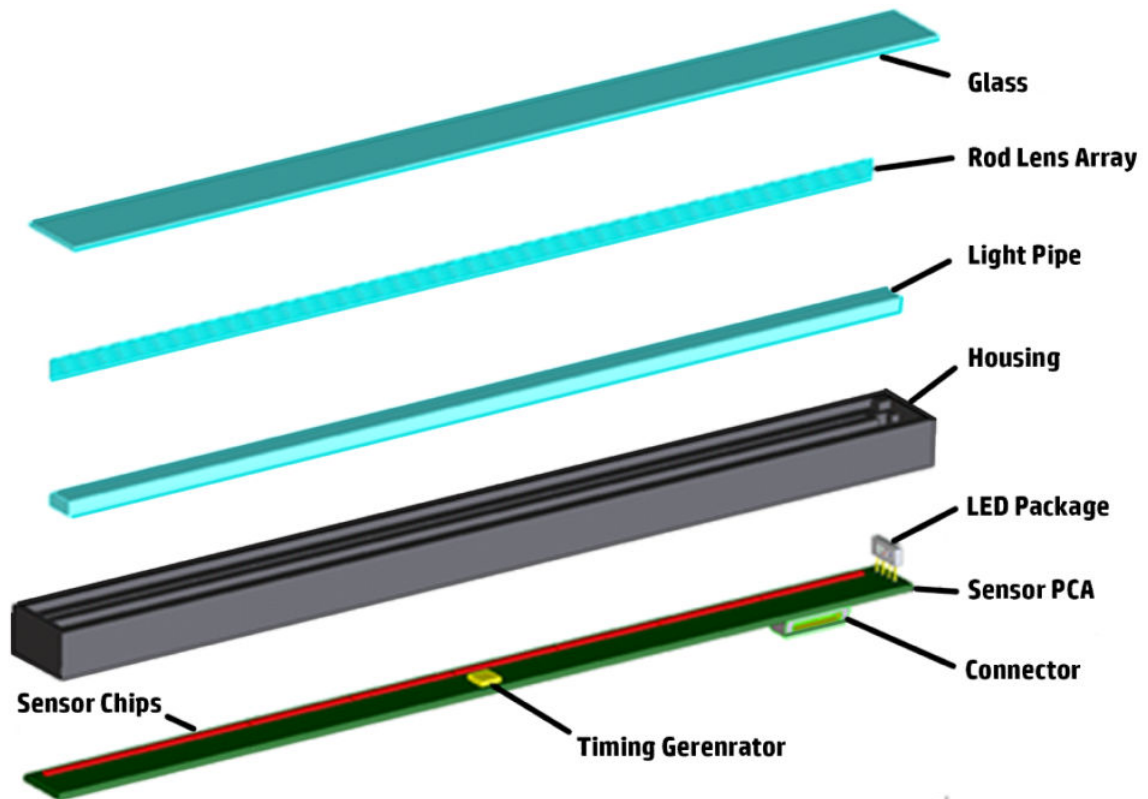

#### Principle of operation:

1. The light source is 3 RGB LEDs that are lit one at a time. The sensor consists of 14960 individual monochrome sensors in 1200PPI.
2. The purpose of the lens is to channel the light from the “pixels” on the image to the sensors. There is no magnification in the lens (1x1).
3. Due to the very short focal length, the focus depth is limited. The original has to be in contact with the surface of the glass plate in order to be in focus.
4. The LEDs flash one at a time, capturing one color at a time.

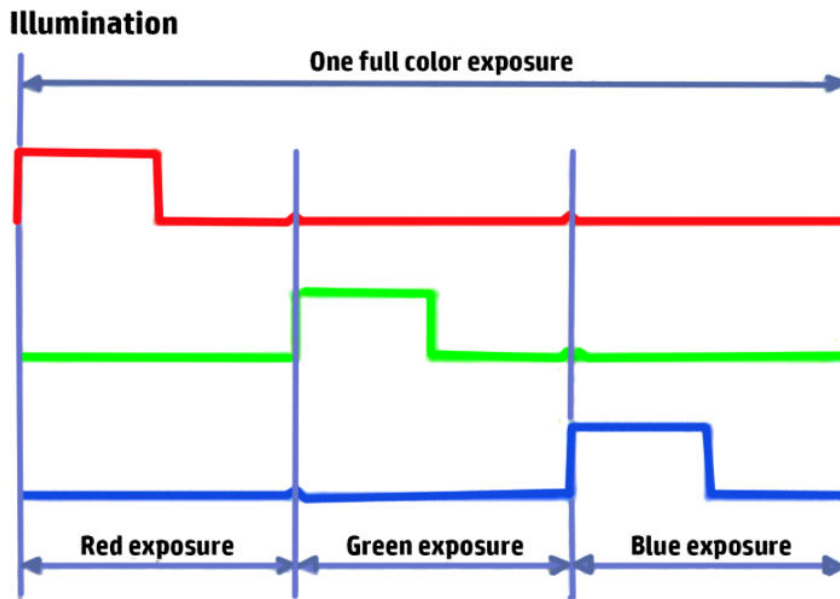

## Calibration Sliders (or Calibration Surfaces)

### Overview

The calibration sliders are used as the white color calibration for the Scanbars. There are 3 sliders; one slider for each Scanbar. The sliders are also used to hold media up against the Scanbars during scans. The normal force is controlled by 4 springs for each slider.

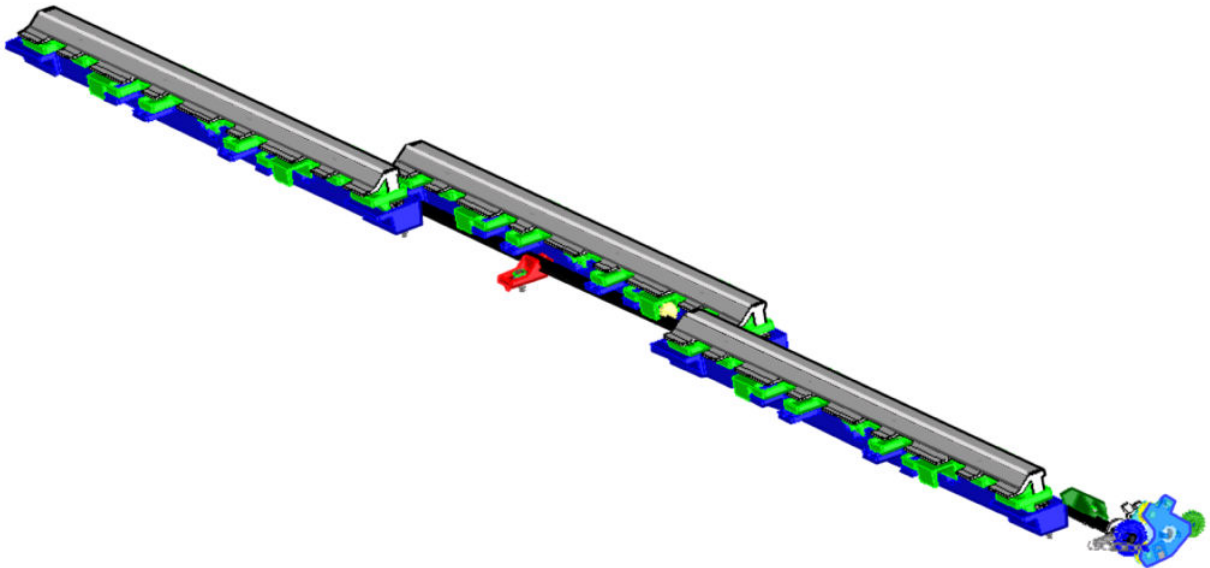

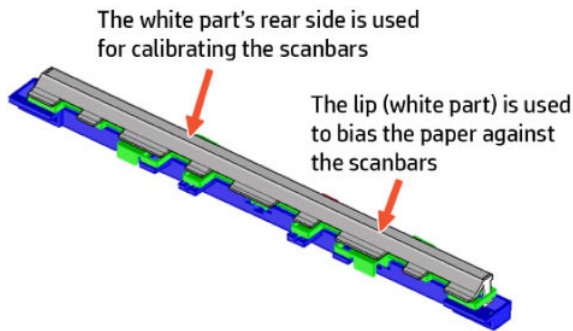

The sliders move 4 mm towards the front of the scanner pushed by cams during PRNU calibration process.

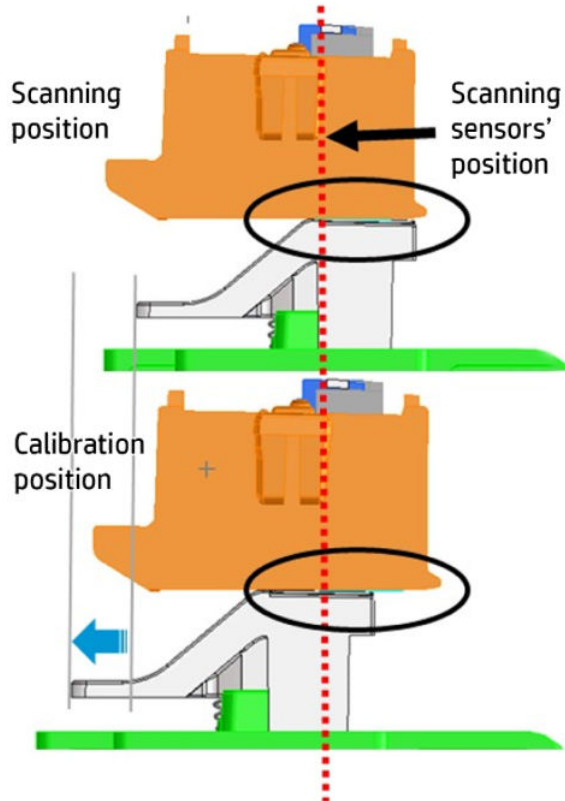

Once sliders are in the forward position, they will slide 4 mm towards the back of the scanner pushed by cams. The cams are attached to a shaft with a gear at the right end. The transmission rotates the cam shaft driven by the rear drive roller.

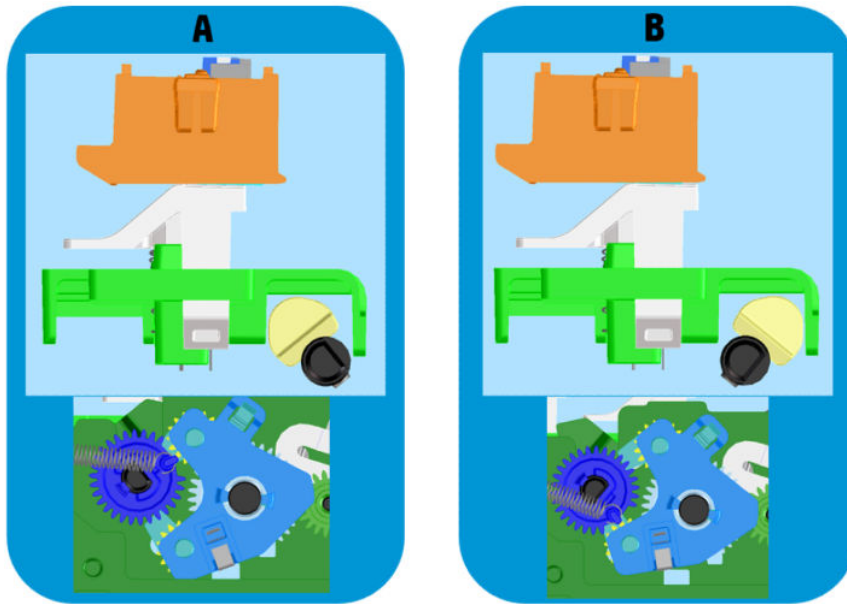

During a scan, media travels up the sliders. Media then pushes the sliders down and travels down the paper path underneath the Scanbars and above the sliders.

There is a rib at the front of the sliders that is 0.25 mm high. This is to keep the scan surface at the Scanbar's focal length of 0.25 mm.

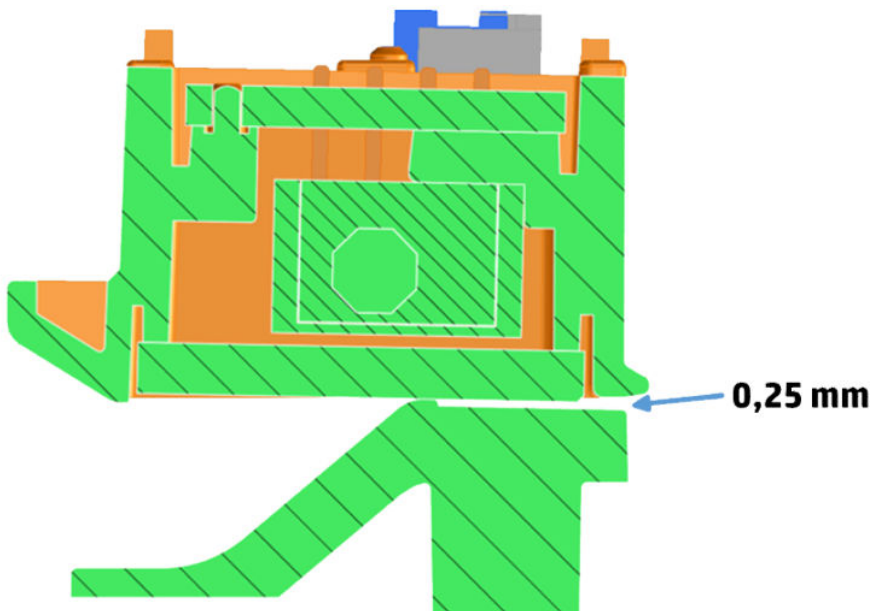

### Original Protection (OPT sensor and OPT wheel)

An original protection algorithm has been implemented to preserve the originals before they crash or jam irrevocably.

- Two sensors in the side, monitor originals with excessive skew that could come into contact with media path walls.

- An idle wheel with encoder (OPT wheel), propelled by the media, gives advance information on discrepancies between the scanner motor encoder and OPT wheel encoder. It also helps to fine tune the advance and improve image quality.

**OPT Wheel**

Tracks paper motion through contact

1. Checks advance vs scan motor to detect jam
2. Position based scanning to improve accuracy

**OPT Side Sensors**

Will shut down if media is too close to the sides of the media path.

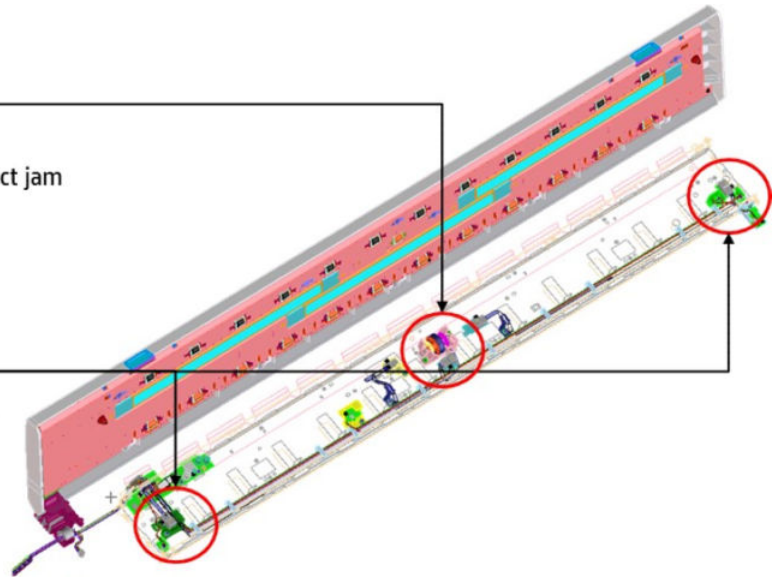



---

## 2 Troubleshooting

- [Printer troubleshooting flowchart: SFP](#)
- [Printer troubleshooting flowchart: MFP](#)
- [Printer startup troubleshooting](#)
- [Basic printer troubleshooting](#)
- [System error codes](#)
- [Paper troubleshooting](#)
- [Communication troubleshooting](#)
- [Manual driver installation](#)
- [Drivers Troubleshooting](#)
- [Ink-supplies troubleshooting](#)
- [Print-quality troubleshooting](#)
- [Print mode summary table](#)
- [Printer Emulation](#)
- [Scan and copy quality troubleshooting](#)
- [The scanner diagnostic plot](#)
- [Scanner jam removal](#)
- [Scan media does not load](#)
- [Update the firmware](#)

# Printer troubleshooting flowchart: SFP

Use the following as a guide to troubleshooting issues with the printer:

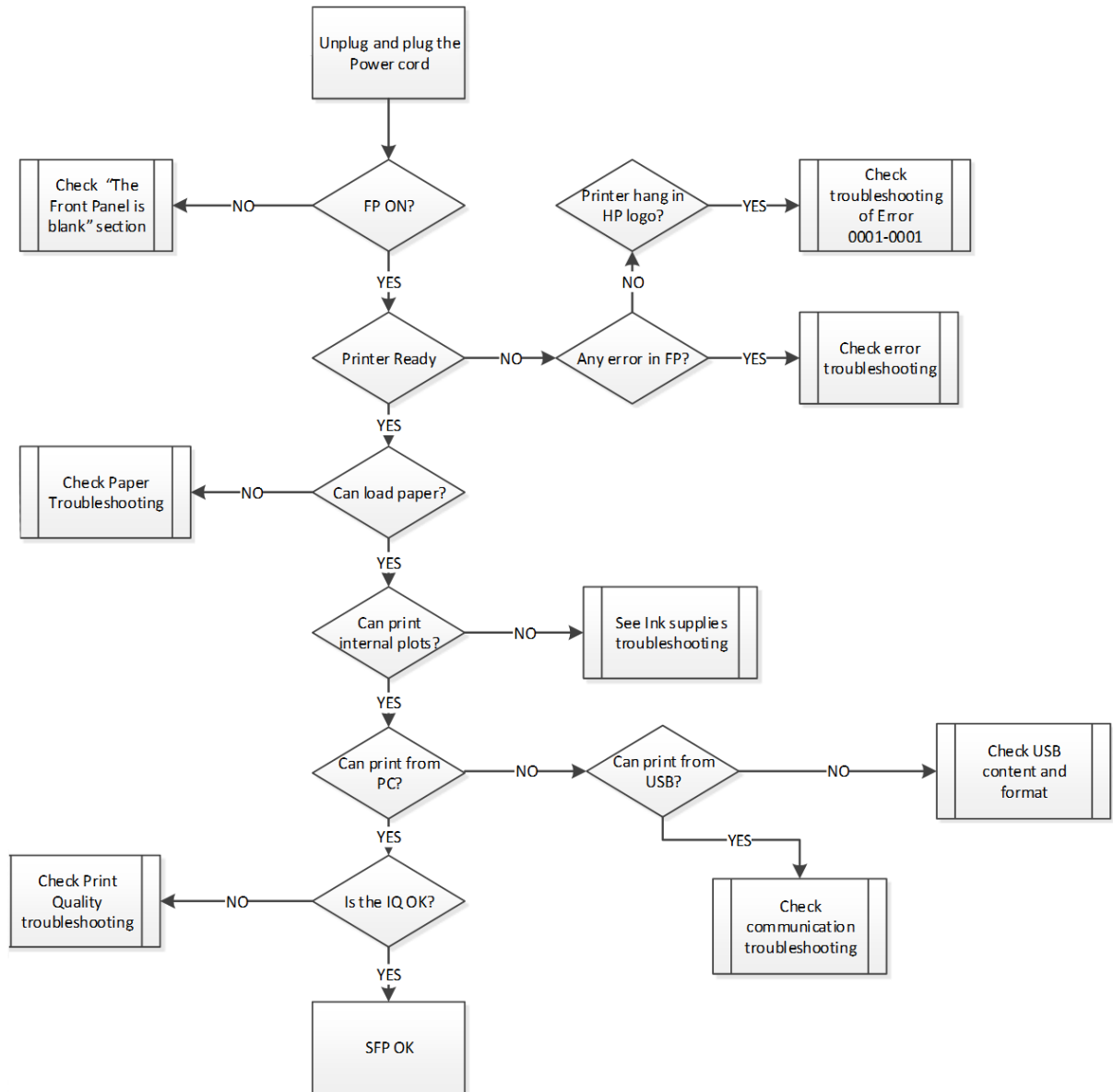



# Printer troubleshooting flowchart: MFP

Use the following as a guide to troubleshooting issues with the printer:

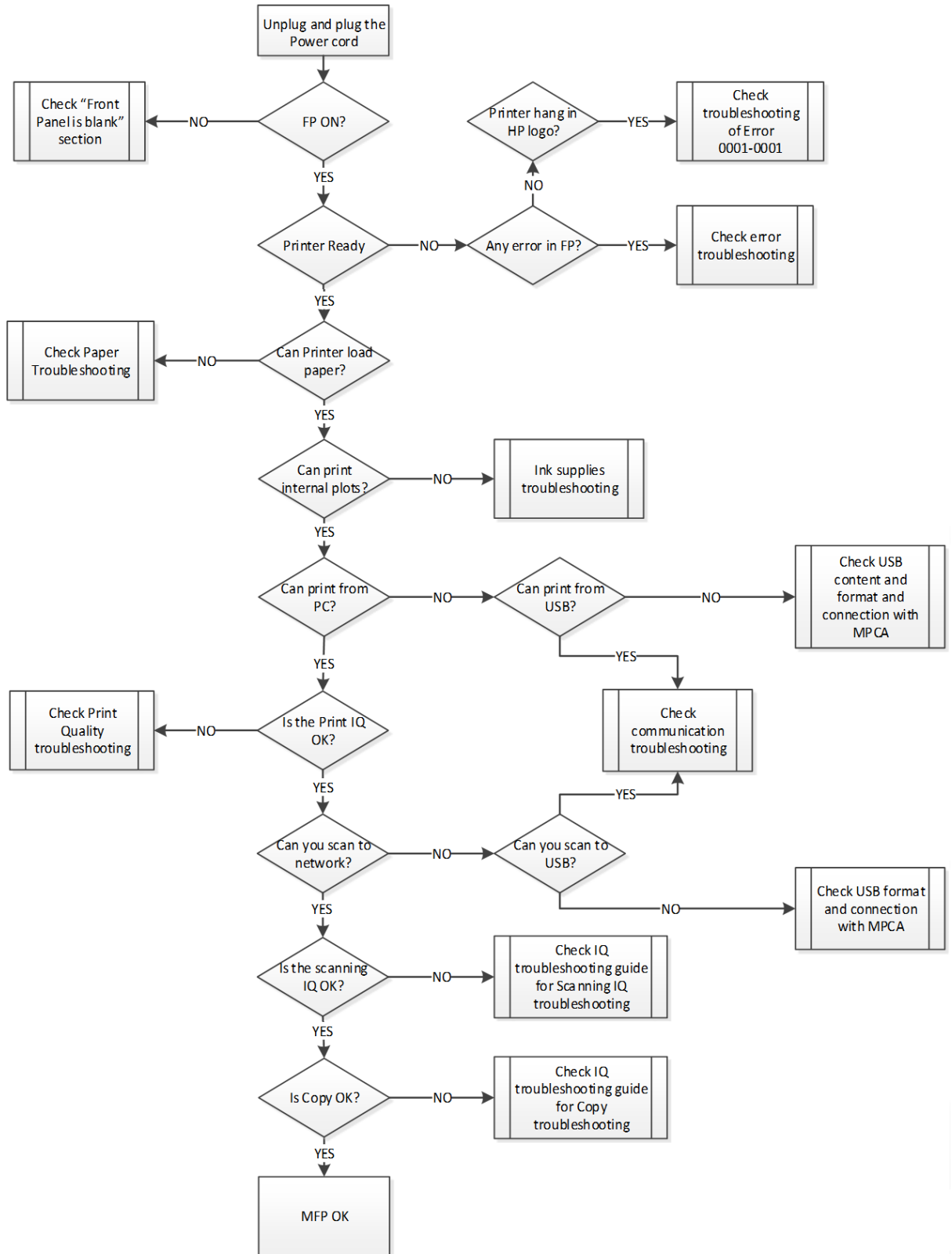

## Printer startup troubleshooting

The following diagram shows all the steps in the printer startup flow related to the tubes and PHA filling. The filling process is the same in the case of PHA replacement.

The process automatically checks that the primer works, that the ink is flowing towards the PHA, and activates the necessary recovery routines if needed. If the process fails in an unrecoverable way, it will be canceled and a specific system error will be shown. Please see the system error section for details on the steps to follow.

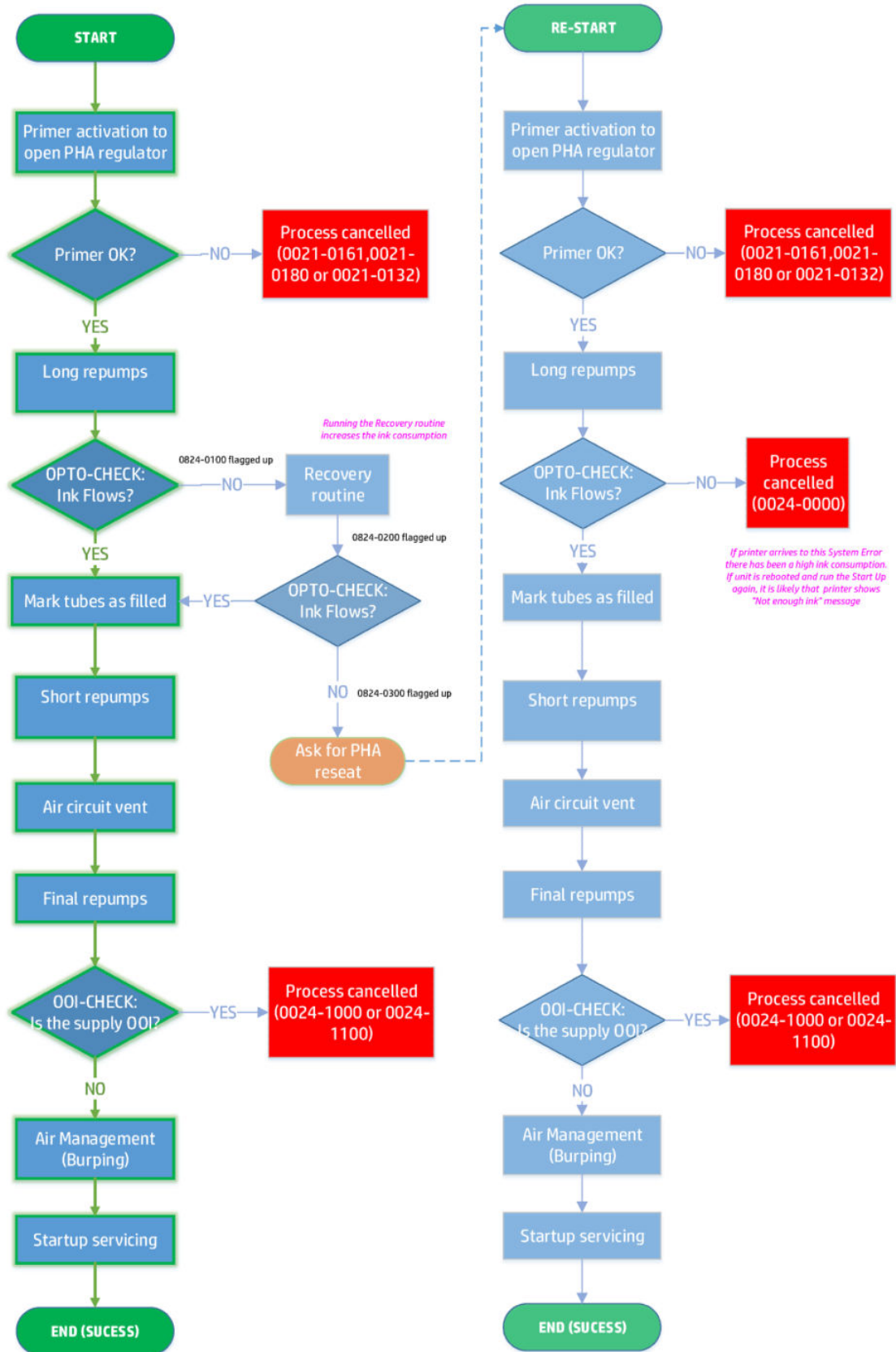

# Basic printer troubleshooting

## The printer does not print

If all is in order (paper loaded, all ink components installed, and no file errors), there are still reasons why a file you have sent from your computer may not start printing when expected:

1. You may have an electrical power problem. If there is no activity at all from the printer, and the front panel does not respond, check that the power cord is connected correctly and that there is power available at the socket.
2. You may be experiencing unusual electromagnetic phenomena, such as strong electromagnetic fields or severe electrical disturbances, which can cause the printer to behave strangely or even stop working. In this case, turn off the printer using the power key on the front panel and unplug the power cord, wait until the electromagnetic environment has returned to normal, then turn it on again. If you still experience problems, please contact your customer service representative.
3. You may not have installed in your computer the correct driver for your printer.
4. If you are printing on a sheet, you must specify Printer Autoselect or Single-Sheet or Multi-Sheet Tray as the paper source in your printer driver.
5. Check connectivity: the LAN cable and the Front Panel WiFi blue light.

## The Front Panel is blank (the printer does not start)

If the printer does not start (the front panel is blank), try the following:

### Remote troubleshooting

1. Ask the customer to unplug and plug in the power cord. The customer should check when the power cord is plugged in that the front panel is illuminated (white) for a few moments, after which the printer should start the initialization process.
2. If the front panel is still blank (does not show a flashing white screen), and the printer does not start up, then ask the customer to hold down the **Power** key for a few seconds and ask to check whether the Power LED button turns orange while the key is held down.
3. If the customer does not see the orange light, no power is reaching the printer; ask to check that the power cord is correctly plugged in. If the problem persists, there is a problem with the power supply. Arrange a service engineer visit to replace the Power Supply, see [Power Supply on page 308](#).
4. If the customer sees the orange light, ask to unplug and plug in the power cord and to listen and wait for around 30 seconds for the printer to make a beeping sound.
5. Three beeps mean that the Front Panel has failed or the Front Panel cable is disconnected or damaged. Arrange a service engineer visit to check the cable and replace the Front Panel if needed, see [Front Panel SFP F9A29-67008 on page 278](#).

6. One long beep means an electronic problem. Arrange for a service engineer visit to replace the Main PCA, see [Main PCA on page 311](#). To check if the issue is with the Main PCA, you can ask the customer to open the Cutter Door (a flat screwdriver is required) and check whether there is a green light (heartbeat LED) flashing in the left bottom part. In order to check the green light, you will need to open the door that is secured with a T15/flat head screw.



If there is no light or it is not flashing the Main PCA should be replaced.

7. If the printer initializes and the Carriage moves but the front panel is still blank, the Front Panel should be replaced, see [Front Panel SFP F9A29-67008 on page 278](#).

See also the troubleshooting flowchart for this issue on the next page.

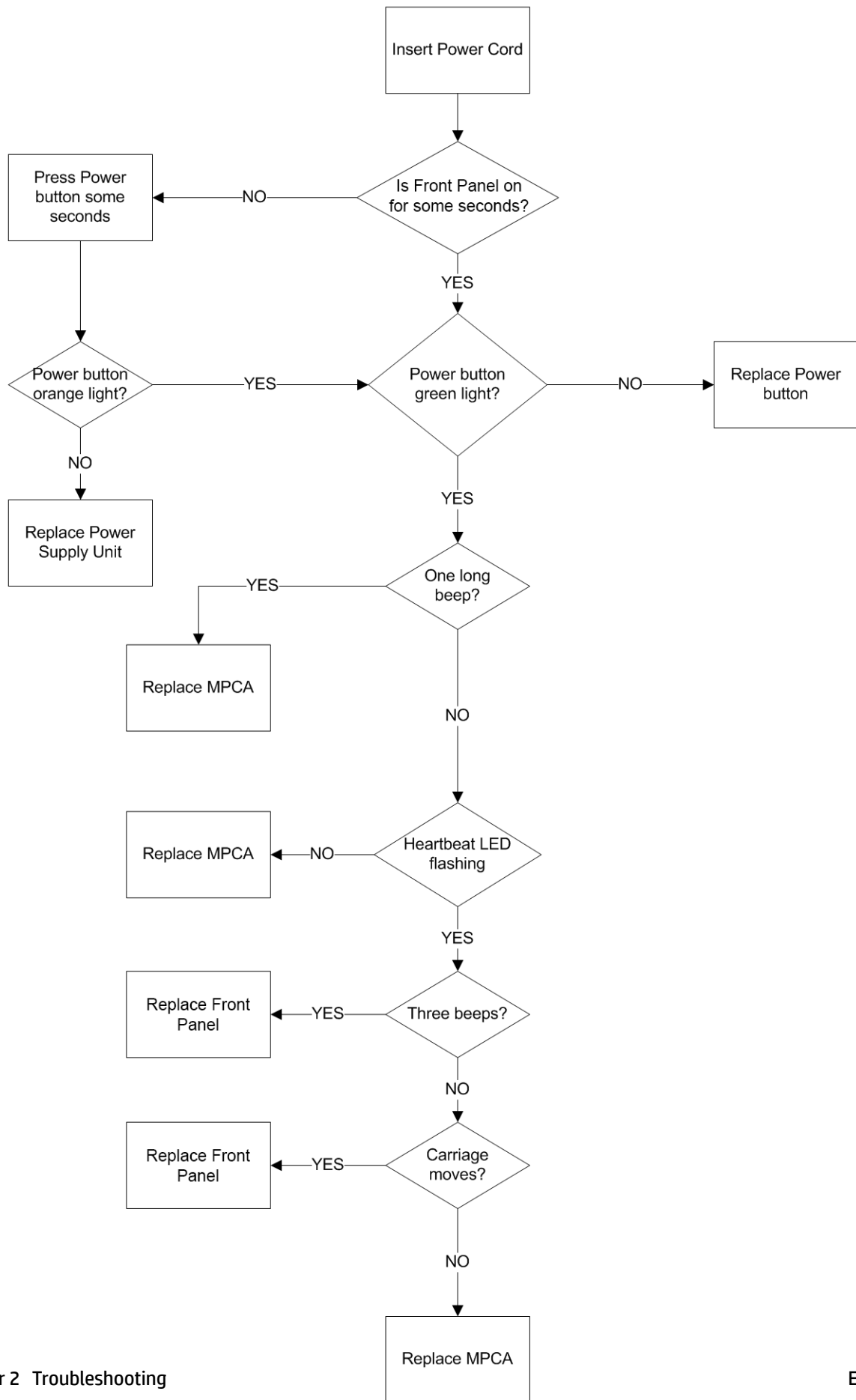

## Printer shows Resuming Screen during OOB

After selecting language, regions, and set time and date, printer gets stuck on the Resuming Screen; typically caused by the PHA door not being closed properly.

### Remote troubleshooting

1. Disconnect from the network and remove any USB pen.
2. Unplug the unit from the wall and wait 30 seconds.
3. Check there is no paper inside the unit.
4. Remove cartridges.
5. Remove PHA.
6. Check the Multi-sheet tray (back) is properly locked.
7. Check all covers are closed:
  - a. PHA door (right side).
  - b. Ink door (top).
  - c. Scanner lid (check the two latches).
  - d. Output tray (front).
  - e. Front window (front).
8. Start the unit.
9. If the problem persists; open and close the PHA door, Ink door, front window, and scanner lid to induce any change.
10. If the problem still persists; power down the unit and insert the PHA with all covers closed.
11. Start the unit.



# System error codes

## Understanding system error codes

Error messages are generally used to report internal system errors. The following pages contain a list of system error codes and their respective descriptions and recommended corrective actions. Try only one recommended action at a time, in the order that they appear, and check whether the error code has disappeared.

## Advisory error messages

Advisory error messages communicate that some action must be performed, such as adding paper or clearing a paper jam. Take the appropriate action to continue printing.

Message or code	Recommendation
[Color] cartridge is very low on ink	Ensure that you have a new cartridge of the same color ready.
Depleted cartridges must be replaced to resume printing	Replace the cartridges as needed.
One or more cartridges appear to be missing or damaged	Insert cartridges of the correct color as needed.
Paper jam	See the user guide or follow front panel instructions.
Paper width is smaller than the minimum size supported by the selected paper source. Load cancelled.	Remove the paper and load paper of the correct size.
Loaded paper is too wide. Manual unload required.	Remove the paper manually and load paper of the correct size.
Paper too far from lateral load line. Please try again.	Remove and reload the paper.
Please manually unload roll paper and try again.	Rewind the roll manually.
Single sheet is loaded with too much skew. Press Eject to unload paper.	Remove and reload the paper.
The current job has been cancelled because the roll is out of paper. Load the roll and send the job again.	Load a new roll.
You are printing a multipage job. Load another sheet to continue printing or cancel the job.	Load another single sheet.
Multi-sheet tray is out of paper. Load paper in multi-sheet tray and press OK to continue printing or cancel the job.	Load paper into the multi-sheet tray.
End of roll has been reached. It is not possible to load the roll.	Load a new roll.
Missing or failed printhead.	Remove and reinsert the same printhead, or try cleaning the electrical connections. If necessary, insert a new printhead.
Refilled or depleted cartridge detected.	Check the cartridge.



## Severe error codes

Severe error messages inform you of a device failure. Some of these messages can be cleared by pressing the power button to turn off the printer, and then pressing it again to turn the printer back on. If a severe error persists, service is required.

<b>System Error Code (DAXX-YYZZ)</b>	<b>Service Part (XX.YY)</b>	<b>Error Cause (ZZ)</b>
0001-0082	01.00. Main PCA	82. Battery or Real time clock ran down
0004-0001	04.00. Print bundle PCA	01. MALFUNCTION_ERROR_STATUS_OR_STATE
0008-0001	08.00. Candela Control Panel	01. MALFUNCTION_ERROR_STATUS_OR_STATE
0009-0000	09.00. Scanner	00. Scanner Generic failure
0009-0101	09.01. Scanner bundle PCA	01. MALFUNCTION_ERROR_STATUS_OR_STATE
0009-0174	09.01. Scanner bundle PCA	74. NVM_ISSUE
0009-0201	09.02. Scanner motor	01. MALFUNCTION_ERROR_STATUS_OR_STATE
0009-0301	09.03. Scanner bar	01. MALFUNCTION_ERROR_STATUS_OR_STATE
0009-0401	09.04. Scanner slider	01. MALFUNCTION_ERROR_STATUS_OR_STATE
0021-0001	21.00. Service station assy	01. MALFUNCTION_ERROR_STATUS_OR_STATE
0021-0017	21.00. Service station assy	17. MOVEMENT_BLOCKED
0021-0132	21.01. Prime pump	32. CURRENT_TOO_LOW
0021-0161	21.01. Prime pump	61. MOTOR_FAULT
0021-0180	21.01. Prime pump	80. AIR LEAK
0024-0000	24.00. Ink Blockage	Last 4 bits interpreted as 0=working 1=not working, order is KCMY
0026-0061	26.00. ISS	61. MOTOR_FAULT
0026-0100	26.01. ISS Opto Trip Sensors	Last 4 bits interpreted as 0=working 1=not working, order is KCMY
0026-0200	26.02. ISS Bongo Malfunction	Last 4 bits interpreted as 0=working 1=not working, order is KCMY
0041-0017	41.00. Paper motor	17. MOVEMENT_BLOCKED
0042-0117	42.01. Carriage motor	17. MOVEMENT_BLOCKED
0043-0017	43.00. Pick motor	17. MOVEMENT_BLOCKED
0045-0017	45.00. Rewinder motor	17. MOVEMENT_BLOCKED
0051-0101	51.01. Top/Front door sensor	01. MALFUNCTION_ERROR_STATUS_OR_STATE
0051-0201	51.02. PHA door sensor	01. MALFUNCTION_ERROR_STATUS_OR_STATE
0051-0301	51.03. Ink door sensor	01. MALFUNCTION_ERROR_STATUS_OR_STATE
0053-0101	53.01. OOP Sensor	01. MALFUNCTION_ERROR_STATUS_OR_STATE
0053-0201	53.02. Output tray sensor	01. MALFUNCTION_ERROR_STATUS_OR_STATE
0059-0190	59.01. Main PCA NVM or NVM Backup PCA	90. NVM_CONFLICT_MAIN_VS_BACKUP
0059-0191	59.01. Main PCA NVM or NVM Backup PCA	91. NVM_DEFAULT_IN_BOTH_MAIN_AND_BACKUP
0059-0289	59.02. NVM Backup PCA	89. BACKUP_NVM_MISSING

<b>System Error Code (DAXX-YYZZ)</b>	<b>Service Part (XX.YY)</b>	<b>Error Cause (ZZ)</b>
0085-0101	85.01. Feed index PCA	01. MALFUNCTION_ERROR_STATUS_OR_STATE
0085-0201	85.02. Feed encoder PCA	01. MALFUNCTION_ERROR_STATUS_OR_STATE
0087-0001	87.00. Encoder strip	01. MALFUNCTION_ERROR_STATUS_OR_STATE
0153-0302	53.03. Multisheet tray sensor	02. CHECK_FAILURE_PRESENCE_INITIALIZATION_ERROR
0359-0073	59.00. Main PCA NVM	73. DERIVATIVE_SETTING
0721-0078	21.00. Service station assy	78. UPDATE_OR_MAINTENANCE_NEEDED
0759-0073	59.00. Main PCA NVM	73. DERIVATIVE_SETTING
0942-0188	42.01. Carriage motor	88. Carriage homing problem
0955-0050	55.00. Carriage Zim sensor SV	50. UNABLE_TO_READ_GET_VALUE

## Silent error codes

Silent error codes help with specific troubleshooting. They are accessible only through the error log and don't appear in the front panel.

<b>System Error Code (DAXX-YYZZ)</b>	<b>Service Part (XX.YY)</b>	<b>Error Cause (ZZ)</b>
0000-0059	00.00. Unknown Service Part	59. MOTOR_SERVO_SHUTDOWN
0021-0059	21.00. Service station assy	59. MOTOR_SERVO_SHUTDOWN
0024-1000	24.10. 00I, Leakage or Missing Ctg	Last 4 bits interpreted as 0=working 1=not working, order is KCMY
0024-1100	24.11. 00I Altered Ctg	Last 4 bits interpreted as 0=working 1=not working, order is KCMY
0026-0075	26.00. ISS	75. Generic Ink supply failure
0026-0085	26.00. ISS	85. Empty supplies
0026-0092	26.00. ISS	92. Too early empty supplies
0026-0093	26.00. ISS	93. EE failure
0026-0094	26.00. ISS	94. Non 00I cartridge failure
0027-0001	27.00. Printhead	"Generic PHA error"
0027-0002	27.00. Printhead	"PHA error: not responding at all"
0027-0003	27.00. Printhead	"PHA error: CSIO xfer completed incorrectly"
0027-0004	27.00. Printhead	"PHA error: Watchdog fault"
0027-0005	27.00. Printhead	"PHA error: Auric data reset"
0027-0006	27.00. Printhead	"PHA error: Unrecognized pen type"
0027-0007	27.00. Printhead	"PHA error: LVDS error"
0027-0008	27.00. Printhead	"PHA error: Pen ID invalid"
0027-0009	27.00. Printhead	"PHA error: Pen ID b/f"
0027-0010	27.00. Printhead	"PHA error: Pen ID write failure"
0027-0011	27.00. Printhead	"PHA error: Bad DTSR"
0027-0012	27.00. Printhead	"PHA error: Temp out of range"
0027-0013	27.00. Printhead	"PHA error: Temp out of range"
0027-0014	27.00. Printhead	"PHA error: TSR fault"
0027-0015	27.00. Printhead	"PHA error: Pen stuck cold"
0027-0016	27.00. Printhead	"PHA error: Pen not heating"
0027-0017	27.00. Printhead	"PHA error: VDD short"
0027-0018	27.00. Printhead	"PHA error: VDD short"
0027-0019	27.00. Printhead	"PHA error: VDD expected on"
0027-0020	27.00. Printhead	"PHA error: VPP short"
0027-0021	27.00. Printhead	"PHA error: VPP short"

<b>System Error Code (DAXX-YYZZ)</b>	<b>Service Part (XX.YY)</b>	<b>Error Cause (ZZ)</b>
0027-0022	27.00. Printhead	"PHA error: VPP short"
0027-0023	27.00. Printhead	"PHA error: VPP short"
0027-0024	27.00. Printhead	"PHA error: VPP short test"
0027-0025	27.00. Printhead	"PHA error: VPP short test"
0027-0026	27.00. Printhead	"PHA error: VPP expected off"
0027-0027	27.00. Printhead	"PHA error: VPP out of range"
0027-0028	27.00. Printhead	"PHA error: VPP out of range"
0027-0029	27.00. Printhead	"PHA error: VPP out of range"
0027-0030	27.00. Printhead	"PHA error: VPP out of range"
0027-0031	27.00. Printhead	"PHA error: VPP out of range"
0027-0032	27.00. Printhead	"PHA error: VPP out of range"
0027-0033	27.00. Printhead	"PHA error: VPP bleed failed"
0027-0034	27.00. Printhead	"PHA error: VDD check timeout"
0027-0035	27.00. Printhead	"PHA error: VPP check timeout"
0027-0036	27.00. Printhead	"PHA error: VPP bleed fuse"
0027-0037	27.00. Printhead	"PHA error: VPP bleed fuse"
0027-0038	27.00. Printhead	"PHA error: VDD too many ignored"
0027-0039	27.00. Printhead	"PHA error: VPP too many ignored"
0027-0040	27.00. Printhead	"PHA error: VPP too many ignored"
0027-0041	27.00. Printhead	"PHA error: VDD check timeout"
0027-0042	27.00. Printhead	"PHA error: VPP check timeout"
0027-0043	27.00. Printhead	"PHA error: VDD check timeout"
0027-0044	27.00. Printhead	"PHA error: VPP check timeout"
0027-0045	27.00. Printhead	"PHA error: VDD on"
0027-0046	27.00. Printhead	"PHA error: VPP on"
0027-0047	27.00. Printhead	"PHA error: VPP setpoint failed"
0027-0048	27.00. Printhead	"PHA error: VPP setpoint failed"
0027-0049	27.00. Printhead	"PHA error: VPP bleed failed"
0027-0050	27.00. Printhead	"PHA error: VPP bleed failed"
0027-0051	27.00. Printhead	"PHA error: VPP bleed failed"
0027-0052	27.00. Printhead	"PHA error: VPP cal out of range"
0027-0053	27.00. Printhead	"PHA error: VPP bleed failed"
0027-0054	27.00. Printhead	"PHA error: VPP bleed failed"
0027-0055	27.00. Printhead	"PHA error: VPP bleed failed"

<b>System Error Code (DAXX-YYZZ)</b>	<b>Service Part (XX.YY)</b>	<b>Error Cause (ZZ)</b>
0027-0056	27.00. Printhead	"PHA error: VPP expected on"
0027-0057	27.00. Printhead	"PHA error: ecc out of range"
0027-0058	27.00. Printhead	"PHA error: ecc out of range"
0027-0059	27.00. Printhead	"PHA error: missing"
0027-0060	27.00. Printhead	"PHA error: wrong part"
0027-0061	27.00. Printhead	"Power on with Filled PHA Change"
0027-0062	27.00. Printhead	"Power on with Empty PHA Change"
0027-0063	27.00. Printhead	"PHA change with Filled PHA"
0027-0064	27.00. Printhead	"PHA change with Empty PHA"
0027-0065	27.00. Printhead	"Out of cap with Filled PHA Change"
0027-0066	27.00. Printhead	"Out of cap with Empty PHA Change"
0027-0067	27.00. Printhead	"Fake PHA Change"
0043-0059	43.00. Pick motor	59. MOTOR_SERVO_SHUTDOWN
0045-0059	45.00. Rewinder motor	59. MOTOR_SERVO_SHUTDOWN
0081-0008	81.00. Media advance	08. JAM
0086-0008	86.00. Scan axis jam	08. JAM
0227-0046	27.00. Printhead	46. NOT_CALIBRATED_MISSALIGNED_UNABLE_TO_CALIBRATE
0824-0100	24.01. Ink Blockage Long Repumps	Last 4 bits interpreted as 0=working 1=not working, order is KCMY
0824-0200	24.02. Ink Blockage Delays Phase	Last 4 bits interpreted as 0=working 1=not working, order is KCMY
0824-0300	24.03. Ink Blockage Bag Cycling Phase	Last 4 bits interpreted as 0=working 1=not working, order is KCMY
0824-2000	24.20. SHAID (Ink detection sensor inside PHA) not covered	Last 4 bits interpreted as 0=working 1=not working, order is KCMY
0942-0188	42.01. Carriage motor	88. Carriage homing problem

## How to interpret severe error codes

Error codes use the “two groups” error code format **DAXX-YYZZ**. The fields are briefly described in the table below:

<b>Field</b>	<b>Description</b>
<b>D</b>	<b>Device Type:</b> 1-digit number from 0 to 9.
<b>A</b>	<b>Action:</b> 1-digit number from 0 to 9.
<b>XX</b>	<b>Module:</b> 2-digit number from 00 to 99.
<b>YY</b>	<b>Service Part:</b> 2-digit number from 00 to 99.
<b>ZZ</b>	<b>Error Cause:</b> 2-digit numbers from 00 to 99.

See below example as reference:

<b>Key</b>	<b>Example: 0041-0017</b>
D: Device Type	0: Printer
A: Actions	0: Replace
XX-YY: Module – Service Part	41-00: Paper motor
ZZ: Error Causes	17: Movement blocked

## Specific error codes for startup and opto trip failures

System Error Code (DAXX-YYZZ)	Service Part (XX.YY)	Error Cause (YY)	Color Coding (ZZ)
0024-0000	24. IDS startup	No ink flow to PHA	See the <b>Color Coding</b> table at the end of <a href="#">How to interpret error codes for startup and opto trip failures on page 75</a>
0024-1000	24. IDS startup	Out of ink ,faulty or missing cartridge	
0024-1100	24. IDS startup	Out of ink detected in altered supplies	
0026-0100	26. ISS	Sensor malfunction	

## How to interpret error codes for startup and opto trip failures

Error codes use the “two groups” error code format **DAXX-YYZZ.**, but with slightly different coding to include the information of the color that is failing. The fields are briefly described in the table below:

Field	Description
<b>D</b>	<b>Device Type:</b> 1-digit number from 0 to 9.
<b>A</b>	<b>Action:</b> 1-digit number from 0 to 9.
<b>XX</b>	<b>Printer function that is failing:</b> 24 (startup) /26 (opto trip failure).
<b>YY</b>	<b>Error Cause:</b> 2-digit numbers from 00 to 99.
<b>ZZ</b>	<b>Color Coding:</b> See table below.

See below example as reference:

Key	Example: 0041-0017
D: Device Type	0: Printer
A: Actions	0: Replace
XX-YY: Module – Service Part	41-00: Paper motor
ZZ: Error Causes	17: Movement blocked

### Color Coding

00	Colors failing not encoded
01	Y failing
02	M failing
03	MY failing
04	C failing
05	CY failing

06	CM failing
07	CMY failing
08	K failing
09	KY failing
0A	KM failing
0B	KMY failing
0C	KC failing
0D	KCY failing
0E	KCM failing
0F	KCMY failing

## System error code troubleshooting

This section describes each of the severe errors that may be encountered while using the printer, and provides the diagnostic method and the actions required to solve the problem detected.

In general, each error is explained for two different situations:

1. For a call agent to solve remotely with the customer
2. If necessary, for an onsite service engineer to solve



**NOTE:** When more than one component could be affected by the system error, replace one component at a time and check whether the error has gone before replacing another component. **Do not replace two electronic parts at same time!** Using this procedure you will be able to determine exactly which component failed.

<b>System error:</b>	<b>0001-0082</b>
<b>Problem description:</b>	Real Time Clock (RTC) Battery ran down.
<b>Other potential parts associated:</b>	None
<b>How to solve.</b>	<p><b>How to solve. Remote troubleshooting (call agent)</b></p> <ol style="list-style-type: none"> <li>1. The call agent asks the customer to go to the <b>Support Menu</b> by pressing the <b>Power key</b> continuously for 15 seconds.</li> <li>2. Go to the <b>Diagnostics Menu</b> and select RTC Battery Status to check whether the RTC Battery has actually expired, see <a href="#">4.10 RTC battery status on page 196</a>.</li> <li>3. If yes, the call agent should arrange a service engineer visit to replace the RTC battery by replacing the Main PCA, see <a href="#">Main PCA on page 311</a>.</li> </ol>



- Main PCA

**Onsite troubleshooting and solution (service engineer)**

1. Replace the Main PCA, see [Main PCA on page 311](#).
2. Switch on the printer and go to **Extended Support Menu** o **Extended Support Menu**. Select **RTC Battery Expired** option from the **Reset Menu in order to** reset the RTC battery expired flag.
3. Go back and select **Set Date and Time** from the **Service Menu** Set the correct date and time.

**System error:**

**0004-0001**

**Problem description:**

Printer Bundle Board communication failure or malfunction

**Other potential parts associated:**

Bundle FFC, Main PCA

**How to solve.**

**How to solve. Remote troubleshooting (call agent)**

1. Switch the power off and disconnect the power cord. Reconnect the power cord and power on the printer.
2. The call agent should arrange a service engineer visit to change the Bundle PCA and follow steps below on Onsite Troubleshooting:
  - Printer Bundle Board
3. If a different system error is displayed then the call agent should perform the applicable troubleshooting procedure.

**Onsite troubleshooting and solution (service engineer)**

1. Remove covers and check that all the cables in the Bundle PCA and associated parts are correctly connected, and that none of them is damaged. If any cable is disconnected then reconnect it, and power on the printer again to check whether the system error has disappeared. **Important note:** If any cable is damaged then order a Cable Service Kit:
  - Cables Sk
2. Replace the Bundle PCA, see [Bundle Board on page 406](#).
  - Printer Bundle Board
3. Replace the Bundle FFC cable, see [Bundle Board FFC cable on page 408](#).
4. Replace the Main PCA (MPCA See [Main PCA on page 311](#))
  - Main PCA

**System error:**

**0008-0001**

**Problem description:**

Front Panel does not respond

**Other potential parts associated:**

None

**How to solve.**

**Onsite troubleshooting and solution (service engineer)**

1. This error never appears in the Front Panel, it is only logged into the Error History, and is equivalent to the 3 beeps during printer startup.
2. It happens when there is no communication between the Front Panel and the Main PCA, see [Printer shows Resuming Screen during OOB on page 67](#).

**System error:**

**0009-0101**

**Problem description:**

Scanner Bundle Board PCA

**Other potential parts associated:**

Main PCA

**Corrective action:**

**How to solve. Remote troubleshooting (call agent)**

1. Switch the power off and disconnect the power cord. Reconnect the power cord and power on the printer.
2. The call agent should arrange a service engineer visit to change the Scanner Bundle PCA, and follow the Onsite troubleshooting below:
  - Scanner Bundle Board
3. If a different system error is displayed then the call agent should perform the applicable troubleshooting procedure.

**Onsite troubleshooting and solution (service engineer)**

1. Remove covers and check that the cables in the Scanner Bundle PCA and associated parts are correctly connected and not damaged. If any cable is disconnected then reconnect it, and power on the printer again to check whether the system error has disappeared.

**IMPORTANT:** If any cable is damaged then order the appropriate Service Kit:

- Cables and Sensors
2. Replace the Scanner Bundle PCA, see [Scan Bundle Board F9A30-67029 on page 433](#).
  3. Replace the Main PCA (MPCA See [Main PCA on page 311](#))
    - Main PCA

**System error:**

**0009-0174**

**Problem description:**

Scanner bundle PCA Non-volatile memory issue

**Other potential parts associated:**

**Corrective action:**

**How to solve. Remote troubleshooting (call agent)**

1. Switch the unit off and on again.
2. If the problem persists, go to the Extended support menu and use the saved Scanner calibrations.

**Onsite troubleshooting and solution (service engineer)**

- ▲ Ensure the Main and Scan Bundle Board are properly connected, or replace Scan Bundle Board.

**System error:**

**0009-0201**

**Problem description:**

Scanner Motor failure

**Other potential parts associated:**

Motor, transmission, pinches, or advance rollers

**Corrective action:**

**How to solve. Remote troubleshooting (call agent)**

1. Switch the power off and disconnect the power cord. Reconnect the power cord and power on the printer.
2. Enter the support menu, see [Entering the support menus on page 182](#), and run the Scanner Media Drive diagnostics test.
3. Depending on the result, the call agent should arrange a service engineer visit to change the scanner motor and transmission, or any of the service parts involved on the media drive.

**Onsite troubleshooting and solution (service engineer)**

1. Replace the scanner motor and transmission.
2. Ensure the pinches and advance rollers turn freely, and the transmission to the sliders works properly.
3. Run the Scanner Media Drive diagnostics test to ensure the system works properly after the repair.

**System error:**

**0009-0301**

**Problem description:**

Scanbar failure

**Other potential parts associated:**

None

**Corrective action:**

**How to solve. Remote troubleshooting (call agent)**

1. Switch the power off and disconnect the power cord. Reconnect the power cord and power on the printer. If the error persists, the call agent should arrange a service engineer visit.
2. Print the scanner diagnostic plot or calibrate it.
3. Scan it and check the result.

**Onsite troubleshooting and solution (service engineer)**

1. Check the Scanbar connections to the main PCA.
2. Replace the Scanbars set, see [Scanbars F9A30-67017 \(HP DesignJet T830 MFP only\) on page 425](#).

**NOTE:** Please remember all 3 scanbars, together with the 3 white calibration surfaces, need to be replaced.

3. Print the scanner calibration plot and calibrate them.

**System error:**

**0009-0401**

**Problem description:**

Scanner Slider failure

**Other potential parts associated:**

None

**Corrective action:**

**How to solve. Remote troubleshooting (call agent)**

Ask the customer to open the scanner lid and check:

1. That none of the sliders surface is stained, dirty or showing symptoms of wear.
2. That the sliders aren't blocked, either:
  - a. In Z (vertical) (the springs should push the slider against the Scanbar when the lid is closed) or;
  - b. In Y (they move back and forth when the lid is open and the paper motion wheels are moved by hand).

**Onsite troubleshooting and solution (service engineer)**

1. If the sliders are in bad condition due to dirt or wear; replace the 3 sliders with new ones.
2. In case of a blocked mechanism in Z; remove the scanner platen and clean any possible paper jam, staple, or whatever else is preventing the slider movement. Ensure that the springs providing the Z movement are in place and work properly.
3. In case of a failure in Y movement; ensure that the transmission located on the right side of the scanner is working properly. It might involve the rear wheels ensuring the original advance motion and the right transmission to the sliders

**System error:**

**0021-0017**

**Problem description:**

Service station is not able to move all the way

**Other potential parts associated:**

Print Bundle PCA

**Corrective action:**

**How to solve. Remote troubleshooting (call agent)**

1. Switch the power off and disconnect the power cord.
2. Open the PHA door and look for paper remains that could be blocking the SVS movement.
3. Reconnect the power cord and power on the printer.
4. The call agent should arrange a service engineer visit to change the Service Station, and follow the Onsite troubleshooting below:
  - Service station assembly
5. If a different system error is displayed then the call agent should perform the applicable troubleshooting procedure.

**Onsite troubleshooting and solution (service engineer)**

1. Remove covers and check that the cables from the Service Station to the Bundle PCA are correctly connected and not damaged. Important note: If any cable is disconnected then reconnect it, and power on the printer again to check whether the system error has disappeared. If any cable is damaged then order a Cable Service Kit.
  - Cables Sk – CQ890-67021
2. Make sure that the Service Station path is clear. Remove any visible obstacles (screws, plastic parts, etc.) restricting the movement of the Service Station.
3. Go to **Support Menu**, see [Entering the support menus on page 182](#) and run the Service Station diagnostic test, see [4.11 Service Station on page 197](#) to check whether the system error has disappeared.
4. Replace the Service Station, see [Service Station on page 334](#).
  - Service station assembly
5. Replace the Bundle Board, see [Bundle Board on page 406](#).
  - Bundle board

**System error:**

**0021-0132**

**Problem description:**

Weak primer motor or underpowered motor

**Other potential parts associated:**

Print Bundle PCA

**Corrective action:**

**How to solve. Remote troubleshooting (call agent)**

1. Switch the power off and disconnect the power cord. Reconnect the power cord and power on the printer.
2. If the issue persists, the call agent should arrange a service engineer visit to change the Priming motor, and follow the Onsite troubleshooting below:

- Priming motor assembly
3. If a different system error is displayed then the call agent should perform the applicable troubleshooting procedure.

**Onsite troubleshooting and solution (service engineer)**

1. Switch the power off and disconnect the power cord. Reconnect the power cord and power on the printer.
2. Remove the covers and check that the cable of the Prime Pump is connected to the Pump and Print Bundle PCA and it is not damaged. Check also for disconnected air tubes, from Prime pump up to carriage coupling

**IMPORTANT:** If the cable is not connected then reconnect it, and power on the printer again to check whether the error has disappeared.

**IMPORTANT:** If the cable is damaged then order a Cable Service Kit:

- Cables Sk
3. Replace the Pump motor, see [Prime Pump on page 340](#).
    - Prime pump
  4. Replace the Print bundle PCA, see [Bundle Board on page 406](#).

**System error:**

**0021-0161**

**Problem description:**

Priming motor or electrical failure

**Other potential parts associated:**

Print Bundle PCA

**Corrective action:**

**How to solve. Remote troubleshooting (call agent)**

1. Switch the power off and disconnect the power cord. Reconnect the power cord and power on the printer.
2. If the issue persists, the call agent should arrange a service engineer visit to change the Priming motor, and follow the Onsite troubleshooting below:
  - Priming motor assembly
3. If a different system error is displayed then the call agent should perform the applicable troubleshooting procedure.

**Onsite troubleshooting and solution (service engineer)**

1. Switch the power off and disconnect the power cord. Reconnect the power cord and power on the printer.
2. Remove the covers and check that the cable of the Prime Pump is connected to the Pump and Print Bundle PCA and it is not damaged.

**IMPORTANT:** If the cable is not connected then reconnect it, and power on the printer again to check whether the error has disappeared.

**IMPORTANT:** If the cable is damaged then order a Cable Service Kit:

- Cables Sk
3. Replace the Pump motor, see [Prime Pump on page 340](#).

- Prime pump

4. Replace the Print bundle PCA, see [Bundle Board on page 406](#).

**System error:**

**0021-0180**

**Problem description:**

Air Leak in Priming System

**Other potential parts associated:**

Prime pump

**Corrective action:**

**How to solve. Remote troubleshooting (call agent)**

1. Switch the power off and disconnect the power cord. Reconnect the power cord and power on the printer.
2. The call agent should arrange a service engineer visit to check or replace the prime air circuit, and follow the Onsite troubleshooting below.
3. If a different system error is displayed then the call agent should perform the applicable troubleshooting procedure.

**Onsite troubleshooting and solution (service engineer)**

1. Switch the power off and disconnect the power cord. Reconnect the power cord and power on the printer.
2. Remove the covers and check that the Prime Pump air circuit has a leakage, and inspect fluidic connections or replace them.

**IMPORTANT:** If fluidic connections are disconnected, reconnect them and ensure they are properly fit.

3. If still there's an obvious leakage, replace them:
  - Fluidic pump – carriage circuit
4. Replace the Pump motor, see [Prime Pump on page 340](#).
  - Prime pump

**System error:**

**0024-0000**

**Problem description:**

The ink does not flow to the PHA during the PHA startup process

**Other potential parts associated:**

PHA, ISS, RIDS

**Corrective action:**

**How to solve. Remote troubleshooting (call agent)**

1. Ask the customer to try the process again. Reseat the PHA and ensure the ink tube connections are correct. Also ask the customer to check supplies are properly inserted. Customer should see a green lock in the tubes, see [Ink Tubes \(RIDS\) on page 17](#).
2. Ask the customer to check the error log (EWS or Front Panel) and list/send the full error log. The last 2 ciphers of the error code indicate the specific PHA failure. The call agent will note the complete system error for failure analysis later.
3. The call agent will arrange the shipment of a PHA replacement kit. If a new PHA does not solve the issue, the call agent should arrange a service visit.

**Onsite troubleshooting and solution (service engineer)**

1. Go to **Support Menu**, see [Entering the support menus on page 182](#), and run the **ISS** diagnostic test, see [4.12 ISS on page 198](#).
2. If the test passes, retry the startup with a new PHA. Check that the PHA is correctly latched to ensure fluidic connection between the printer RIDS and PHA, and check the supplies are properly inserted.
3. If the startup fails again with the same error code, replace the RIDS, see [RIDS \(Ink Tubes\) on page 494](#).

**System error:**

**0024-1000**

**Problem description:**

Out of ink ,faulty or missing cartridge during the PHA startup process

**Other potential parts associated:**

Supplies

**Corrective action:**

**How to solve. Remote troubleshooting (call agent)**

1. This error can show up if any of the supplies has popped out during the ink pumping sequence. Ask the customer to open the ISS door and check that all the supplies are well in position. If any of the supplies has popped out, ask the customer to reinsert it/them and retry the startup.
2. If all the supplies were well inserted, ask the customer to try the process again with a new supply. It is not required to replace the PHA as the same one can be used to retry the process.
3. If the supply was prematurely detected as OOI, the call agent will arrange a shipment for the faulty HP supply replacement.
4. The last 2 ciphers of the error code indicate the specific PHA failure. The call agent will note the complete system error for failure analysis later.

**System error:**

**0024-1100**

**Problem description:**

Out of ink detected in altered supplies during the startup process



<b>Other potential parts associated:</b>	PHA
<b>Corrective action:</b>	<p><b>How to solve. Remote troubleshooting (call agent)</b></p> <ol style="list-style-type: none"> <li>1. Ask the customer to try the process again with a new unused HP supply. It is not required to replace the PHA as the same one can be used to retry the process.</li> <li>2. The last 2 ciphers of the error code indicate the specific PHA failure. The call agent will note the complete system error for failure analysis later.</li> </ol>
<b>System error:</b>	<b>0026-0061</b>
<b>Problem description:</b>	ISS motor stall or bad encoder disc
<b>Other potential parts associated:</b>	None
<b>Corrective action:</b>	<p><b>How to solve. Remote troubleshooting (call agent)</b></p> <ol style="list-style-type: none"> <li>1. Restart the unit. If the problem persists, then:</li> <li>2. Run Service diagnostic test to verify ISS.</li> <li>3. Arrange visit with ISS Service kit.</li> </ol> <p><b>Onsite troubleshooting and solution (service engineer)</b></p> <ol style="list-style-type: none"> <li>1. Run ISS diagnostic test. If issue persists, then:</li> <li>2. Replace the ISS, see <a href="#">ISS on page 499</a>.</li> <li>3. Run the Service diagnostics test to verify ISS motor and sensors.</li> </ol>
<b>System error:</b>	<b>0026-0100</b>
<b>Problem description:</b>	ISS Optotrip failure
<b>Other potential parts associated:</b>	None
<b>Corrective action:</b>	<p><b>How to solve. Remote troubleshooting (call agent)</b></p> <ol style="list-style-type: none"> <li>1. Switch the power off and disconnect the power cord. Reconnect the power cord and power on the printer.</li> <li>2. Go to <b>Support Menu</b>, see <a href="#">Entering the support menus on page 182</a> and run the <b>ISS</b> diagnostic test, see <a href="#">4.12 ISS on page 198</a>.</li> <li>3. Depending on the result, the call agent should arrange a service engineer visit to change the ISS.</li> </ol> <p><b>Onsite troubleshooting and solution (service engineer)</b></p> <ol style="list-style-type: none"> <li>1. Ensure the ISS cables are properly fit, and reconnect them as needed.</li> <li>2. Ensure there isn't any ink spot or media debris around the opto sensors that might prevent their correct function.</li> <li>3. Replace the ISS, see <a href="#">ISS on page 499</a>.</li> </ol>

**System error:** 0026-0200

**Problem description:** ISS Bongo Malfunction

**Other potential parts associated:**

**Corrective action:** **How to solve. Remote troubleshooting (call agent)**

- ▲ Check ink supplies. Ensure they are genuine HP ink supplies.

**System error:** 0026-XXXX

**Problem description:** Silent S.E. for troubleshooting

**System error:** 0027-00XX

**Problem description:** PHA problem

**Other potential parts associated:** Carriage PCA, Trailing Cable, Main PCA

**Corrective action:** **How to solve. Remote troubleshooting (call agent)**

1. Remove, clean and reseal PHA kit. Also, check if ink tubes latch and PHA latch are properly closed (Green Lock).
2. The last 2 ciphers of the error code indicate the specific PHA failure. The call agent will note the complete system error. for later failure analysis.
3. If the PHA is still in warranty, the call agent will arrange a shipment with a PHA replacement.

**System error:** 0041-0017

**Problem description:** Unable to move Paper Servo or no feedback received.

**Other potential parts associated:** Feed Encoder Sensor PCA, Feed Index Sensor PCA, Feed Encoder Disk

**Corrective action:** **How to solve. Remote troubleshooting (call agent)**

1. Switch the power off and disconnect the power cord. Reconnect the power cord and power on the printer.
2. The call agent asks the customer to go to **Support Menu** by pressing the **Power key** continuously for 15 seconds.
3. Go to **Diagnostic Menu**, see [Entering the support menus on page 182](#) and run **Paper Servo** diagnostic, see [4.4 Paper servo on page 188](#).
4. After running the diagnostic the printer will show one of these system errors:
  - 0081-0008 arrange a service engineer to replace Paper/Feed motor and follow the Onsite Troubleshooting explained below, see [Paper Motor on page 317](#).

- Paper Motor
  - 0085-0101 need to replace Feed encoder sensor PCA and follow the [Onsite troubleshooting and solution \(service engineer\) on page 95](#) explained for error 0085-0201.
  - 0085-0201 need to replace Feed encoder sensor PCA and follow the [Onsite troubleshooting and solution \(service engineer\) on page 95](#) explained for error 0085-0201.
5. The call agent should arrange a service engineer visit to replace the right part depending on the system error.

**Onsite troubleshooting and solution (service engineer)**

1. Remove covers and check that all the cables are well connected to the Main PCA, specially the paper motor cable, and none of them are damaged. If any of the cables is not connected, then reconnect it, and power on the printer again to check whether the system error has disappeared. Check that there are no debris, media or foreign objects preventing drive shaft movement.

**IMPORTANT:** If any cable is damaged then order a Cable Service Kit:

- Cables Sk
2. Run Paper Servo diagnostic, see [4.4 Paper servo on page 188](#). After running the diagnostic check for the following system errors:

After running the diagnostic the printer will show one of these system errors:

- 0081-0008 arrange a service engineer to replace Paper/Feed motor and follow the Onsite Troubleshooting explained below, see [Paper Motor on page 317](#).
    - Paper Motor
  - 0085-0101 need to replace Feed encoder sensor PCA and follow the [Onsite troubleshooting and solution \(service engineer\) on page 95](#) explained for error 0085-0201.
  - 0085-0201 need to replace Feed encoder sensor PCA and follow the [Onsite troubleshooting and solution \(service engineer\) on page 95](#) explained for error 0085-0201.
3. If the 0041-0017 error continues then the Paper/Feed motor should be replaced. See [Paper Motor on page 317](#).
- Paper Motor
4. Replace the Main PCA, see [Main PCA on page 311](#).
- Main PCA

**System error:** 0042-0117

**Problem description:** Unable to move Carriage Servo or no feedback received.

**Other potential parts associated:**

Trailing Cables, Carriage Board, Carriage Motor, Carriage Belt, Encoder Strip

**Corrective action:**

**How to solve. Remote troubleshooting (call agent)**

1. Switch the power off and disconnect the power cord. Reconnect the power cord and power on the printer.
2. The call agent asks the customer to go to **Support Menu** by pressing the **Power key** continuously for 15 seconds.
3. Go to **Diagnostic Menu**, see [Entering the support menus on page 182](#) and run **Carriage Servo** diagnostic, see [4.3 Carriage servo on page 187](#).
4. The call agent should arrange a service engineer visit to change the carriage motor.

**Onsite troubleshooting and solution (service engineer)**

1. Check that the Carriage Motor belt is not broken or out of place, and the pulley on the SVS side turns freely and horizontal.
2. If the belt and pulley are OK, then the Carriage Motor should be replaced, see [Carriage Motor on page 374](#).
  - Carriage Motor
3. If the belt was damaged, it should be changed. Order the belt service kit, see [Carriage Belt on page 351](#).
  - Belt (36)

**System error:**

**0043-0017**

**Problem description:**

Unable to move Pick Servo or no feedback received.

**Other potential parts associated:**

None

**Corrective action:**

**How to solve. Onsite troubleshooting and solution (service engineer)**

1. Remove the covers and check that all the cables are well connected to the Printer Bundle Board (right side of the unit), specially the pick motor cable, and none of them are damaged. If any cable is not connected, then reconnect it, and power on the printer again to check whether the system error has disappeared.

Check right hand gear train for blockage or damage.

**IMPORTANT:** If any cable is damaged, then order a Cable Service Kit:

- Cables Sk
2. Replace the Pick motor.

**System error:**

**0045-0017**

**Problem description:**

Unable to move Rewind Servo or no feedback received.

**Other potential parts associated:**

Main PCA

**Corrective action:**

**How to solve. Remote troubleshooting (call agent)**

1. Switch the power off and disconnect the power cord. Reconnect the power cord and power on the printer.
2. Remove the spindle, check the spindle gear and gear cap position. Check rewinder gears for damage. Finally, boot the unit without the spindle.
3. The call agent should arrange a service engineer visit to change the Rewinder module, and follow the Onsite troubleshooting below:
  - Left Roll Support
4. If a different system error is displayed then the call agent should perform the applicable troubleshooting procedure.

**Onsite troubleshooting and solution (service engineer)**

1. Remove the covers and check that the cables of the rewinder module are correctly connected to the Main PCA, and that none of them are damaged. If any cable is disconnected then reconnect it, and power on the printer again to check whether the system error has disappeared.

**IMPORTANT:** If any cable is damaged then order a Cable Service Kit:

- Cables Sk
2. Replace the Left Roll Support. See [Left Roll Support on page 292](#).
    - Left Roll Support
  3. Replace the Main PCA, see [Main PCA on page 311](#).
    - Main PCA

**System error:**

**0051-0101**

**Problem description:**

Top (SFP) or Front (MFP) Cover sensor failure

**Other potential parts associated:**

Main PCA

**Corrective action:**

**How to solve. Remote troubleshooting (call agent)**

1. Switch off the printer, and disconnect the power cord. Reconnect the power cord and power on the printer.
2. The call agent asks the customer to go to **Support Menu** by pressing the **Power key** continuously for 15 seconds.
3. **Top Cover Sensor** can be tested opening and closing the window (see [4.14 Additional Manual Sensor Test \(not included in the Service Menu\) on page 200](#)).
4. The call agent should arrange a service engineer visit to change the Top Cover Sensor PCA; follow the onsite troubleshooting below.

- Top Cover Sensor

5. If a different system error is displayed then the call agent should perform the applicable troubleshooting procedure.

**Onsite troubleshooting and solution (service engineer)**

1. Go to **Support Menu** (see [Entering the support menus on page 182](#)) and run **Top Cover Sensor** diagnostic, see [4.14 Additional Manual Sensor Test \(not included in the Service Menu\) on page 200](#).
2. Replace the Top Cover Sensor PCA.
3. Remove the covers and check that the cables of the rewinder module are correctly connected to the Main PCA, and that none of them are damaged. If any cable is disconnected then reconnect it, and power on the printer again to check whether the system error has disappeared.

**IMPORTANT:** If any cable is damaged then order a Cable Service Kit:

- Cables Sk

4. Replace the Main PCA, see [Main PCA on page 311](#):

- Main PCA

**System error:**

**0051-0201**

**Problem description:**

PHA door sensor failure

**Other potential parts associated:**

Main PCA

**Corrective action:**

**How to solve. Remote troubleshooting (call agent)**

1. Switch off the printer, and disconnect the power cord. Reconnect the power cord and power on the printer.
2. The call agent asks the customer to go to **Support Menu** by pressing the **Power key** continuously for 15 seconds.
3. **PHA door sensor** can be tested opening and closing the PHA door (see [4.14 Additional Manual Sensor Test \(not included in the Service Menu\) on page 200](#)).
4. The call agent should arrange a service engineer visit to change the PHA door Sensor PCA; follow the onsite troubleshooting below.
  - PHA door sensor SV kit
5. If a different system error is displayed then the call agent should perform the applicable troubleshooting procedure.

**Onsite troubleshooting and solution (service engineer)**

1. Check that the cable of the PHA door sensor is connected to Main PCA and is undamaged. If the cable is not connected then reconnect it, and power on the printer again to check that the error has disappeared.

**IMPORTANT:** If any cable is damaged then order a Cable Service Kit:

- Cables Sk

2. Replace the PHA door Sensor PCA:

- PHA door Sensor
3. Replace the Main PCA, see [Main PCA on page 311](#):
- Main PCA

**System error:**

**0051-0301**

**Problem description:**

Ink Cartridge door sensor failure

**Other potential parts associated:**

Main PCA

**Corrective action:**

**How to solve. Remote troubleshooting (call agent)**

1. Switch off the printer, and disconnect the power cord. Reconnect the power cord and power on the printer.
2. The call agent asks the customer to go to **Support Menu** by pressing the **Power key** continuously for 15 seconds.
3. Go to **Diagnostic Menu**, see [Entering the support menus on page 182](#) and run **Ink door Sensor** diagnostic, see [4.14 Additional Manual Sensor Test \(not included in the Service Menu\) on page 200](#).
4. The call agent should arrange a service engineer visit to change the Ink Cartridge door Sensor PCA; follow the onsite troubleshooting below.
  - Ink Cartridge Cover Sensor
5. If a different system error is displayed then the call agent should perform the applicable troubleshooting procedure.

**Onsite troubleshooting and solution (service engineer)**

1. Check that the cable of the Ink Cartridge door sensor is connected to Main PCA and is undamaged. If the cable is not connected then reconnect it, and power on the printer again to check that the error has disappeared.

**IMPORTANT:** If any cable is damaged then order a Cable Service Kit:

- Cables Sk
2. Replace the Ink Cartridge door Sensor PCA, see [Printer NVM backup PCA on page 305](#):
    - Ink Cartridge door Sensor
  3. Replace the Main PCA, see [Main PCA on page 311](#):
    - Main PCA

**System error:**

**0053-0101**

**Problem description:**

OOP (Out-Of-Paper) Sensor failure

**Other potential parts associated:**

Bundle PCA, Bundle FFC, Main PCA

**Corrective action:**

**How to solve. Remote troubleshooting (call agent)**

1. Switch off the printer, and disconnect the power cord. Reconnect the power cord and power on the printer.
2. The call agent should recommend the customer to power off the printer, remove the Multi-tray sheet module, and check that there is no paper behind it, then power on the printer to see whether the error continues.
3. Ask the customer to check if the OOPS sensor is not dislodged from its location. If yes, reseal the OOPS sensor.
4. The call agent asks the customer to go to **Support Menu** by pressing the **Power key** continuously for 15 seconds.
5. Go to **Diagnostic Menu**, see [Entering the support menus on page 182](#) and run **OOP Sensor** diagnostic, see [4.5 Out-Of-Paper Sensor on page 190](#).
6. If error persists, send the customer an OOP Sensor module SV kit (CSR B part).
7. If a different system error is displayed then the call agent should perform the applicable troubleshooting procedure.
8. If, after the customer replaces the OOP Sensor, the failure still continues, the failure may be due to the OOP Sensor cable, so the call agent should order an onsite engineer with the cables kit:
  - Cables Sk
  - OOP Sensor flag

**Onsite troubleshooting and solution (service engineer)**

1. Go to **Support Menu**, see [Entering the support menus on page 182](#) and run **OOP Sensor** diagnostic, see [4.5 Out-Of-Paper Sensor on page 190](#).
2. Remove the Multi-Sheet Tray at the back of the printer, see [Multi-Sheet Tray Assembly on page 367](#), and check that there is no paper jammed in the OOP sensor; check also that the sensor is assembled correctly.
3. Replace the OOP Sensor assembly, see [Out-Of-Paper Sensor on page 388](#).
  - OOP Sensor flag
4. Remove the covers and check that the cable of the OOP sensor is connected to Bundle PCA and is not damaged. If the cable is not connected then reconnect it, and power on the printer again to check whether the system error has disappeared.

**IMPORTANT:** If any cable is damaged then order a Cable Service Kit:

  - Cables Sk
5. Replace the Bundle PCA, see [Bundle Board on page 406](#).
  - Bundle Board
6. Replace the Bundle FFC cable, see [Bundle Board FFC cable on page 408](#).
7. Replace the Main PCA, see [Main PCA on page 311](#).
  - Main PCA



<b>System error:</b>	<b>0053-0201</b>
<b>Problem description:</b>	Output Tray sensor failure
<b>Other potential parts associated:</b>	Main PCA, Output tray
<b>Corrective action:</b>	<p><b>How to solve. Remote troubleshooting (call agent)</b></p> <ol style="list-style-type: none"> <li>1. Switch off the printer, and disconnect the power cord. Reconnect the power cord and power on the printer.</li> <li>2. The call agent asks the customer to go to <b>Support Menu</b> by pressing the <b>Power key</b> continuously for 15 seconds.</li> <li>3. Go to <b>Diagnostic Menu</b>, see <a href="#">Entering the support menus on page 182</a> and run <b>Output Tray Sensor</b> diagnostic, see <a href="#">4.6 Output Tray Sensor on page 191</a>.</li> <li>4. The call agent should send to the customer the Output Tray Sensor, which is a CSR part. <ul style="list-style-type: none"> <li>• Output Tray Sensor Assembly</li> </ul> <p><b>NOTE:</b> If, after the customer repair, the issue still continues, we recommend sending an onsite engineer with Cables Kit and Output Tray Sensor PCA. Follow the steps below on onsite troubleshooting.</p> <ul style="list-style-type: none"> <li>• Cables Sk</li> <li>• Output Tray Sensor PCA</li> </ul> </li> <li>5. If a different system error is displayed then the call agent should perform the applicable troubleshooting procedure.</li> </ol> <p><b>Onsite troubleshooting and solution (service engineer)</b></p> <ol style="list-style-type: none"> <li>1. Go to <b>Support Menu</b>, see <a href="#">Entering the support menus on page 182</a> and run <b>Output Tray Sensor</b> diagnostic, see <a href="#">4.6 Output Tray Sensor on page 191</a>. Check that the Output Tray is not damaged.</li> <li>2. If the Output Tray is OK and the problem continues then replace the Output Tray Sensor PCA. <ul style="list-style-type: none"> <li>• Output Tray Sensor PCA</li> </ul> </li> <li>3. Remove the covers and check that the cable of the Output Tray Sensor is connected to the Main PCA and is not damaged. If the cable is not connected then reconnect it, and power on the printer again to check whether the system error has disappeared. <p><b>IMPORTANT:</b> If the cable is damaged then order a Cable Service Kit (add part number and name of Cable Service Kit) and change the Output Tray sensor cable: see <a href="#">Output Tray Extender Sensor Cable on page 398</a>.</p> <ul style="list-style-type: none"> <li>• Output Tray Sensor Assembly</li> </ul> </li> <li>4. Replace the Main PCA, see <a href="#">Main PCA on page 311</a>. <ul style="list-style-type: none"> <li>• Main PCA</li> </ul> </li> </ol>
<b>System error:</b>	<b>0059-0190</b>
<b>Problem description:</b>	Conflict found between NVM main and backup

<b>Other potential parts associated:</b>	None
<b>Corrective action:</b>	<p><b>How to solve. Onsite troubleshooting and solution (service engineer)</b></p> <ol style="list-style-type: none"> <li>1. The error appears if during a service operation, the Main PCA or the NVM backup PCA are replaced by a reused part (not a new spare part).</li> <li>2. To recover, repair using HP genuine new spare parts.</li> </ol>
<b>System error:</b>	<b>0059-0191</b>
<b>Problem description:</b>	Default data found in both NVM main and backup
<b>Other potential parts associated:</b>	None
<b>Corrective action:</b>	<p><b>How to solve. Onsite troubleshooting and solution (service engineer)</b></p> <ol style="list-style-type: none"> <li>1. The error appears if during a service operation, the Main PCA and the NVM backup PCA are replaced at the same time.</li> <li>2. To recover, repair by changing first one component (use the old component for this printer), then power the printer off and on, and change the other.</li> </ol>
<b>System error:</b>	<b>0059-0289</b>
<b>Problem description:</b>	NVM backup is missing or does not work correctly (NVM location, see <a href="#">Locations of the PCAs on page 47</a> ).
<b>Other potential parts associated:</b>	None
<b>Corrective action:</b>	<p><b>How to solve. Remote troubleshooting (call agent)</b></p> <p>▲ Restart the unit. If the problem persists, then:</p> <p><b>Onsite troubleshooting and solution (service engineer)</b></p> <ol style="list-style-type: none"> <li>1. Remove left cover, see <a href="#">Left Cover MFP SV Kit F9A30-67012 on page 268</a>, and ensure NVM backup cable is properly connected to it and to the Main PCA.</li> <li>2. Replace the NVM backup.</li> </ol>
<b>System error:</b>	<b>0085-0101</b>
<b>Problem description:</b>	Feed index encoder sensor does not work properly
<b>Other potential parts associated:</b>	Feed Encoder Disk, Main PCA
<b>Corrective action:</b>	<p><b>How to solve. Remote troubleshooting (call agent)</b></p> <ol style="list-style-type: none"> <li>1. Switch off the printer, and disconnect the power cord. Reconnect the power cord and power on the printer.</li> <li>2. The call agent should arrange a service engineer visit to change the Feed Index PCA and follow onsite troubleshooting below.</li> </ol>

- Feed Index encoder sensor PCA
3. If a different system error is displayed then the call agent should perform the applicable troubleshooting procedure.

**Onsite troubleshooting and solution (service engineer)**

1. Remove the covers and check that all the cables are well connected to the Main PCA, and none of them are damaged. If any cable is not connected then reconnect it, and power on the printer again to check whether the system error has disappeared.

**IMPORTANT:** If any cable is damaged then order a Cable Service Kit:

- Cables Sk
2. Replace the Feed Index Encoder Sensor PCA, see [Encoder PCA and Index on page 319](#)
    - Feed Index encoder sensor PCA
  3. Check that the Encoder Disk is not dirty or damaged. If the Encoder Disk is damaged, it should be replaced, see [Encoder Disk on page 323](#).
    - Encoder Disk

**System error:**

**0085-0201**

**Problem description:**

Feed encoder sensor does not work properly

**Other potential parts associated:**

Feed encoder Disk, Main PCA

**Corrective action:**

**How to solve. Remote troubleshooting (call agent)**

1. Switch off the printer, and disconnect the power cord. Reconnect the power cord and power on the printer.
2. The call agent should arrange a service engineer visit to change the Feed encoder sensor PCA.
  - Feed Encoder Sensor PCA
3. If a different system error is displayed then the call agent should perform the applicable troubleshooting procedure.

**Onsite troubleshooting and solution (service engineer)**

1. Remove the covers and check that all the cables are well connected to the Main PCA, and none of them are damaged. If any cable is not connected then reconnect it, and power on the printer again to check whether the system error has disappeared.

**IMPORTANT:** If any cable is damaged then order a Cable Service Kit:

- Cables Sk
2. Replace the Feed Encoder Sensor PCA, see [Encoder PCA and Index on page 319](#).
    - Feed Encoder Sensor PCA
  3. Check that the Encoder Disk is not dirty or damaged. If the Encoder Disk is damaged it should be replaced, see [Encoder Disk on page 323](#).
    - Encoder Disk

**System error:**

**0087-0001**

<b>Problem description:</b>	Encoder Strip failure
<b>Other potential parts associated:</b>	Carriage (encoder sensor)
<b>Corrective action:</b>	<p><b>How to solve. Remote troubleshooting (call agent)</b></p> <ol style="list-style-type: none"> <li>1. Switch off the printer, and disconnect the power cord. Reconnect the power cord and power on the printer.</li> <li>2. The call agent should arrange a service engineer visit to change the Encoder Strip and follow onsite troubleshooting below. <ul style="list-style-type: none"> <li>• Encoder Strip (36)</li> </ul> </li> <li>3. If a different system error is displayed then the call agent should perform the applicable troubleshooting procedure.</li> </ol> <p><b>Onsite troubleshooting and solution (service engineer)</b></p> <ol style="list-style-type: none"> <li>1. Remove the covers and check that Encoder Strip is not broken or dirty. <ul style="list-style-type: none"> <li>• Cables Sk</li> </ul> </li> <li>2. If the Encoder Strip is dirty, follow the procedure in this manual to clean it, see <a href="#">Clean the Encoder Strip on page 531</a>.</li> <li>3. If the Encoder strip is damaged or does not work, it should be replaced, see <a href="#">Encoder Strip on page 300</a>.</li> <li>4. If this fails to solve the issue, the problem might be due to the encoder sensor within the carriage. In that case, replace the carriage, see <a href="#">Carriage and Belt on page 344</a>.</li> </ol>

**System error:** 0153-0302

**Problem description:** Multi-Sheet Tray presence not detected

**Other potential parts associated:** MPCA

**Corrective action:** **How to solve. Remote troubleshooting (call agent)**

- ▲ Ensure that the Multi-Sheet Tray is properly placed and the latch is closed.

**Onsite troubleshooting and solution (service engineer)**

- ▲ Ensure that the Multi-Sheet Tray sensor cable is correctly connected to the MPCA, checking the J27 connector in the MPCA.

**System error:** 0824-XXXX

**Problem description:** IDS startup problem: Silent System Errors not shown in the Front Panel. Refer to Ink supplies troubleshooting for more information, see [Ink-supplies troubleshooting on page 122](#). See [Error messages related with printhead and start-up on page 130](#) for additional error codes.

**System error:** 0942-0188

**Problem description:** Carriage homing problem

**Other potential parts associated:**

None

**Corrective action:**

**How to solve. Remote troubleshooting (call agent)**

1. Reboot the unit. If the problem persists, clean the encoder strip, see [Clean the Encoder Strip on page 531](#).
2. If the issue is not solved, open the PHA door and check if there's any paper strips blocking either the carriage or the SVS.
3. Go to **Diagnostic Menu**, see [Entering the support menus on page 182](#) and run **Carriage Servo** diagnostic, see [4.3 Carriage servo on page 187](#).

**Onsite troubleshooting and solution (service engineer)**

1. Check encoder strip, scan axis and service station parts.
2. Depending on the failing subsystem, any one of them may need replacing.

**System error:**

**0955-0050**

**Problem description:**

Line sensor failure

**Other potential parts associated:**

Carriage PCA, Trailing Cable, Main PCA

**Corrective action:**

**How to solve. Remote troubleshooting (call agent)**

1. Switch off the printer, and disconnect the power cord. Reconnect the power cord and power on the printer.
2. The call agent asks the customer to go to **Support Menu** by pressing the **Power key** continuously for 15 seconds.
3. Go to **Diagnostic Menu** and run the **Line Sensor** diagnostic, see [4.7 Line Sensor \(or ZIM, Spot sensor\) on page 192](#).
4. The call agent should arrange a service engineer visit to change the Line Sensor assembly; follow the onsite troubleshooting below.
  - Line Sensor
5. If a different system error is displayed then the call agent should perform the applicable troubleshooting procedure.

**Onsite troubleshooting and solution (service engineer)**

1. Go to **Support Menu** (see [Entering the support menus on page 182](#)) and run the **Line Sensor** diagnostic, see [4.7 Line Sensor \(or ZIM, Spot sensor\) on page 192](#).
2. Remove the covers and check that the cable of the line sensor is connected to the Carriage PCA and it is not damaged. If the cable is not connected then reconnect it, and power on the printer again to check whether the error has disappeared.

**IMPORTANT:** If the cable is damaged then replace the Line Sensor, see [Carriage Line Sensor on page 402](#).

- Line Sensor
3. Clean the Line Sensor and try again, see [Clean the Carriage Line Sensor on page 530](#).
  4. Replace the Carriage Assembly, see [Carriage and Belt on page 344](#).

- Carriage assembly w/belt (36)
5. Replace the Main PCA, see [Main PCA on page 311](#)
- Main PCA

## Other possible errors

Although infrequent, there are errors and asserts that can be displayed in the Front Panel in a different format. Usually these errors are solved by turning the printer off and on. Examples of these errors are shown here:

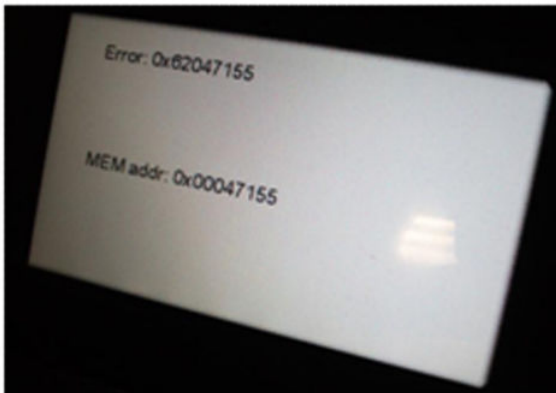
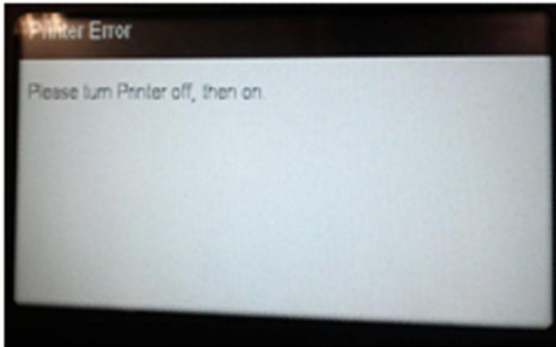

## How to get the system error log

To see the last 50 system errors on the Front Panel, go to the Service Menu, enter the Information Menu, and request the error history; see [1.6 Error history on page 185](#).

To print the error history, go to the Service Menu, enter the Reports Menu, and request the error history; see [6.6 Error history on page 208](#).

To check the error log via EWS go to **Tools ► Reports ► Error Log**.

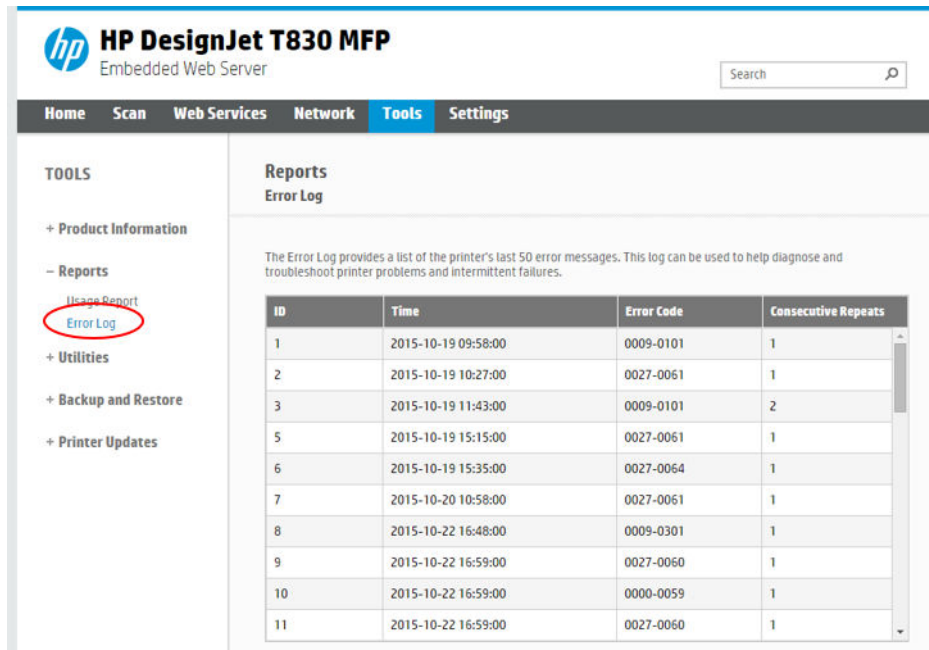

The screenshot shows the HP DesignJet T830 MFP Embedded Web Server interface. The top navigation bar includes Home, Scan, Web Services, Network, Tools, and Settings. The 'Tools' menu is expanded, showing options like Product Information, Reports, Utilities, Backup and Restore, and Printer Updates. Under the 'Reports' section, 'Error Log' is highlighted with a red circle. The main content area displays the 'Error Log' page, which includes a table of the printer's last 50 error messages. The table has columns for ID, Time, Error Code, and Consecutive Repeats.

ID	Time	Error Code	Consecutive Repeats
1	2015-10-19 09:58:00	0009-0101	1
2	2015-10-19 10:27:00	0027-0061	1
3	2015-10-19 11:43:00	0009-0101	2
5	2015-10-19 15:15:00	0027-0061	1
6	2015-10-19 15:35:00	0027-0064	1
7	2015-10-20 10:58:00	0027-0061	1
8	2015-10-22 16:48:00	0009-0301	1
9	2015-10-22 16:59:00	0027-0060	1
10	2015-10-22 16:59:00	0000-0059	1
11	2015-10-22 16:59:00	0027-0060	1

## Paper troubleshooting

Use the following section to troubleshoot paper-related issues when the problem has not been solved by following the troubleshooting of paper issues in the user's guide.

For every paper issue, first make sure you have reviewed the paper supported by the product (type and size). Also make sure the customer has followed the user's guide instructions to load the paper. In summary, check that the customer is:

- Using supported paper
- Using appropriate paper path
- Following the front-panel instructions

For further detailed information about HP Large-Format Printing Supplies, see <http://www.hp.com/go/designjet/supplies>.

### Paper specifications:

	Minimum	Maximum
Roll width	279 mm (11 in)	914 mm (36 in)
Roll length		46 m (150 feet)
Roll diameter		100 mm (3.9 in)
914 mm (36 in) roll weight		6.2 kg (14 lb)
Sheet width	210 mm (8.27 in)	914 mm (36 in)
Sheet length	279 mm (11 in)	1676 mm (66 in)
Paper thickness		0.3 mm (0.01 in)
Paper weight	60 g/m <sup>2</sup>	280 g/m <sup>2</sup> (220 g/m <sup>2</sup> in multi-sheet tray)
Multi-sheet tray stacking capacity		5 mm height

## Paper cannot be loaded successfully

### Remote troubleshooting (call agent)

- Check that the customer has followed the paper troubleshooting included in the user's guide, if not, help the customer to do it.
- If the problem persists, ask the customer to restart the printer.
- If the paper still cannot be loaded after restarting, follow the next recommendations depending on the type of paper the user is trying to load (roll, single sheet, or from the Multi-Sheet Tray).

### Unsuccessful roll load

1. Ensure that the Output Tray is closed. If the Output Tray is open, ask the customer to close it and try to load the roll again.
2. Check spindle hubs and roll directionality feed under or over.



3. Ask the customer to try to print from the Multi-Sheet Tray. If he can print from the Multi-Sheet Tray, it means that the OOP sensor and the paper motor work correctly. Ask the customer to re-check that there are no pieces of paper stuck in the paper path.
4. If no anomalies are detected, ask the customer to cut 10 cm of the paper roll or use a new roll (if possible) and try to load the roll again.
5. If no anomalies are detected, ask the customer to run the OOP sensor diagnostics (see [4.5 Out-Of-Paper Sensor on page 190](#)). If they fail the OOP sensor should be replaced, arrange the shipment of an OOP sensor (CSR A part) to the customer.
6. If the OOP sensor diagnostics pass, arrange a service engineer visit to diagnose the issue.

#### Unsuccessful sheet load

1. Ensure that the Output Tray is closed. If the Output Tray is open, ask the customer to close it and try to load the sheet again.
2. Ask the customer to try to print from the Multi-Sheet Tray. If he can print from the Multi-Sheet Tray, it means that the OOP sensor and the paper motor work correctly. Ask the customer to re-check that there are no pieces of paper stuck in the paper path.
3. If no anomalies are detected, ask the customer to try to load a different paper type (roll or single sheet). If the load is successful, check with the customer that the type of paper failing to load is a supported paper.
4. If the paper is supported, ask the customer to run the OOP sensor diagnostics (see [4.5 Out-Of-Paper Sensor on page 190](#)). If the diagnostics fail, the OOP sensor should be replaced, arrange the shipment of an OOP sensor (CSR A part) to the customer.
5. If the OOP sensor diagnostics pass, arrange a service engineer visit to diagnose the issue.

#### Unsuccessful load from the Multi-Sheet Tray

1. Ask the customer to remove all the sheets from the Multi-Sheet Tray, and load only one sheet (A4 or A3). Try to print. If the load is correct, ensure that the customer has not loaded too many sheets into the tray, also that the paper is supported.
2. Ask the customer to ensure that the Multi-Sheet Tray is well positioned.
3. If one sheet works OK, but it fails with several, it could mean that there is a problem with the Multi-Sheet Tray. To check this, ask the customer if roll or single sheet can be loaded successfully. If yes, the Multi-Sheet Tray should be replaced, arrange the shipment of a Multi-Sheet Tray (CSR A part) to the customer.
4. If it is impossible to load a sheet through the Multi-Sheet Tray, and neither roll nor single sheet can be loaded, ask the customer to remove the Multi-Sheet Tray and re-check whether there is any piece of paper stuck in the tray.
5. If no anomalies are detected, ask the customer to run the OOP sensor diagnostics (see [4.5 Out-Of-Paper Sensor on page 190](#)). If they fail, the OOP sensor should be replaced, arrange the shipment of an OOP sensor (CSR A part) to the customer.
6. If the OOP sensor diagnostics pass, arrange a service engineer visit to diagnose the issue.

#### Onsite troubleshooting

The service engineer should first follow the paper troubleshooting procedure in the user's guide, and also the instructions in this manual given to the customer by the call agent to double-check that the troubleshooting

has been done correctly. In most cases the problem can be solved by following these instructions. If the problem persists, try the following:

1. Remove covers and check that there is no broken part in the following:
  - Starwheel rail
  - Pinchwheels
  - Strange noise in motor or Drive Roller
  - Upper paper guide is out of place or broken
  - Out-Of-Paper Sensor is badly positioned
2. If any defective or broken part is found, it should be replaced.

## Multisheet Tray Sensor issues: Printer displays wrong status for Multisheet Tray

### Onsite troubleshooting

In case front panel messages do not match actual tray status the issue may be related with the Multisheet Tray sensor.

1. If the printer informs that the tray is detached when it is not: Clean the mirror in the tray or check whether it is missing. Ultimately, replace the Multisheet Sensor.
2. If the printer informs media is present when it is not: Clean the mirror in the tray or check for media pieces obstructing the sensor.
3. If the printer informs media is not present when it is: The printer will trigger the loading action anyway after a job is sent, if the media is there, it will be picked up and moved to the Out of Paper sensor that will detect the media.

## Media jam removal

When a paper jam occurs, you normally see a message about it in the front-panel display.

### If the printer is a T830 MFP

1. Open the roll cover.

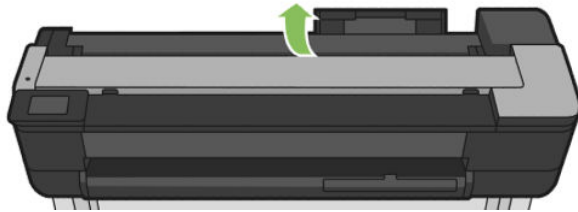

2. Rewind the roll. You may feel resistance if the paper is stuck; pull firmly.

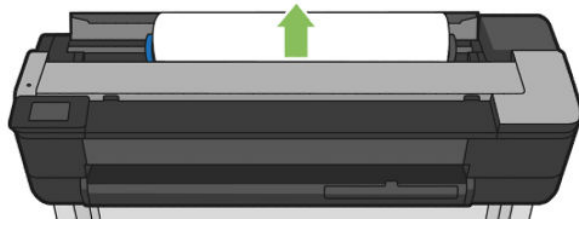

3. Cut the paper if needed

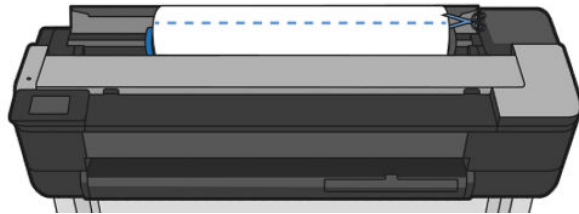

4. Rewind the roll.



5. Carefully remove any of the jammed paper that you can lift up and out from the top of the printer.

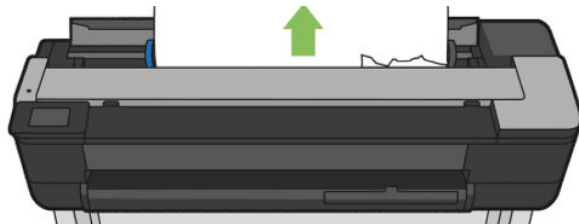

6. Open the front window.



7. Try to move the printhead carriage out of the way.

8. Carefully remove any of the jammed paper that you can from the front window.

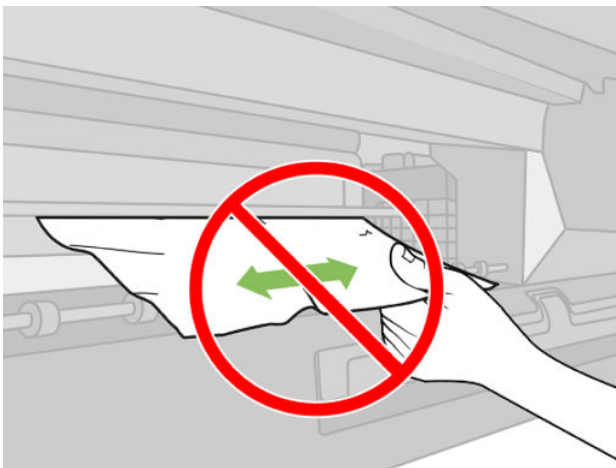
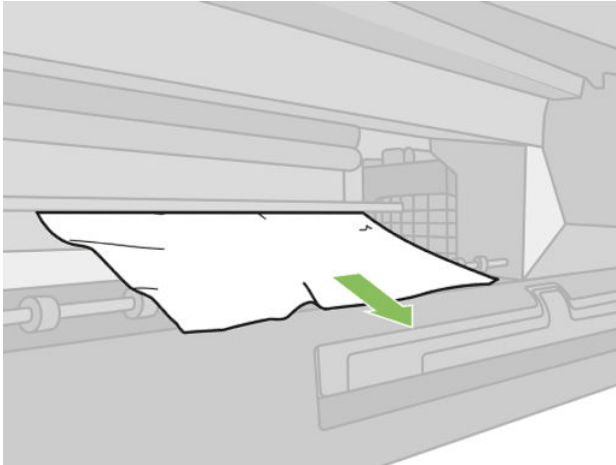

---

**⚠ CAUTION:** Take care not to damage printer's inside components.

**CAUTION:** Do not move the paper sideways, as it could damage the printer.

---

9. Close the front window.



10. Close the roll cover.

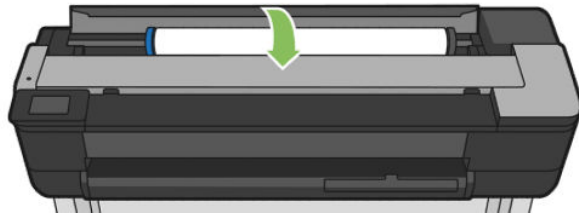

11. Reload the roll, or load a new sheet.

### If the printer is a T730 Printer

1. Open the roll cover.



2. Open the top window.

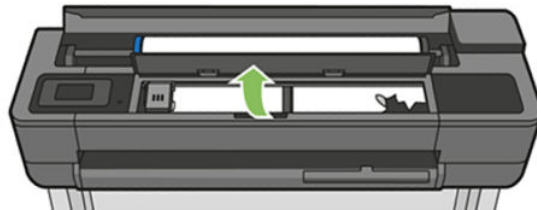

3. Remove any of the jammed paper that you can lift up and out from the top of the printer.

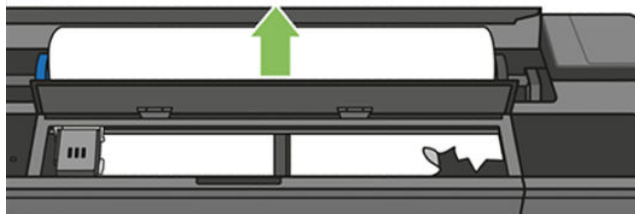

4. Cut the paper if needed

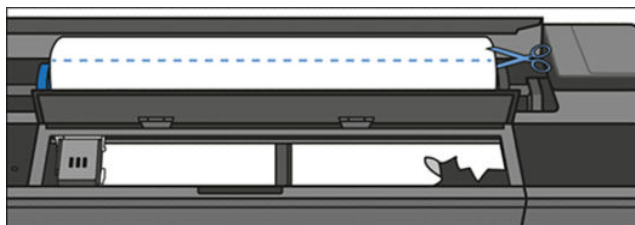

5. Try to move the printhead carriage out of the way.

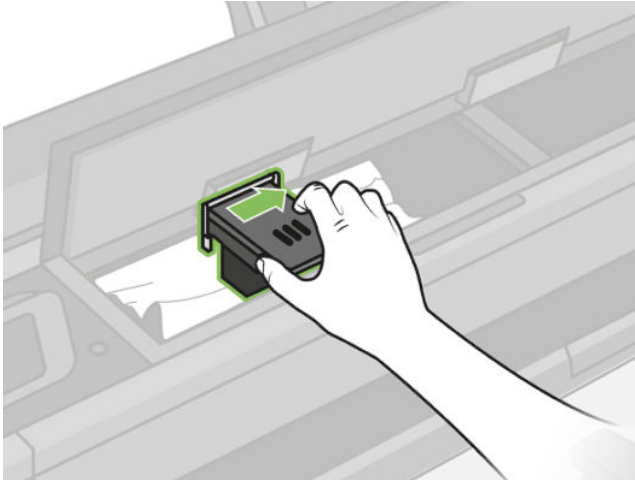

6. Carefully remove any of the jammed paper that you can lift up and out from the top of the printer.

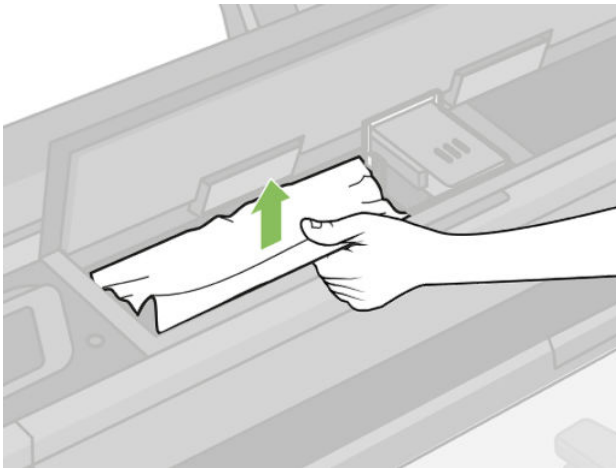

7. Remove any of the jammed paper from the top window.



8. Close the top window.

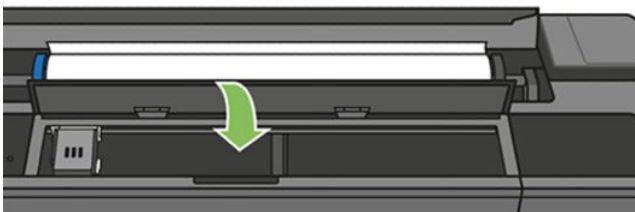

9. Load the paper roll again.

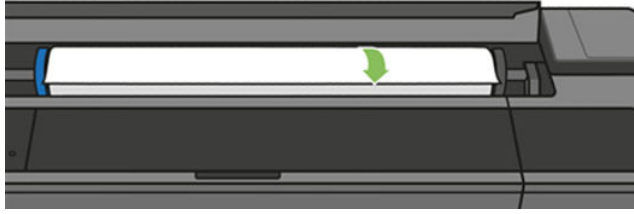

10. Close the roll cover.



11. Reload the roll, or load a new sheet.



**NOTE:** If you find that there is still some paper causing an obstruction within the printer, restart the procedure and carefully remove all pieces of paper. You may need to remove the multi-sheet tray (see [Multi-Sheet Tray Assembly on page 367](#)).

## Printer displays out of paper when paper is available

### Remote troubleshooting

- Check if the customer has followed the paper troubleshooting included in the user's guide. If not, help him or her to do it.
- If the problem persists, ask the customer to unload paper, restart the printer and ask to load paper again. If everything is OK, it is likely the printer has an old firmware version, ask the customer to do an firmware upgrade.
- If there is a problem with the printer is likely that the customer cannot load paper after restarting the printer, in this case see [Paper cannot be loaded successfully on page 100](#).

### Onsite troubleshooting

The service engineer should first follow the paper troubleshooting in the user's guide, and also the instructions in this manual given to the customer by the call agent to double-check that the troubleshooting has been done correctly. In most cases the problem can be solved by following these instructions. If the problem persists:

1. Remove the covers and check that the OOP sensor is well placed and the flag is not broken.
2. Check the cables to see whether any of them is broken or disconnected (especially the OOPS cable and the cable in the Bundle Board).
3. If everything is OK, replace the Bundle Board (see [Bundle Board on page 406](#)).
4. If the problem persists, replace the Main PCA (see [Main PCA on page 311](#)).

## Cutter does not cut, or does not cut well

### Remote troubleshooting

- Check that the customer has followed the paper troubleshooting included in the user's guide. If not, help him or her to do it.
- If the problem persists, ask the customer to check whether the cutter has been disabled in the front panel and/or in the driver.
- Ask to try a different paper, and try to cut it using Form Fit and Cut from the front panel menu.
- If is still not cutting, ask the customer to check that the cutter is engaged and that it moves together with the Carriage. If the cutter is not activated, ask the customer to open the Ink Cartridge Cover and check whether there is a strip of paper in the parking position causing the cutter not to activate.

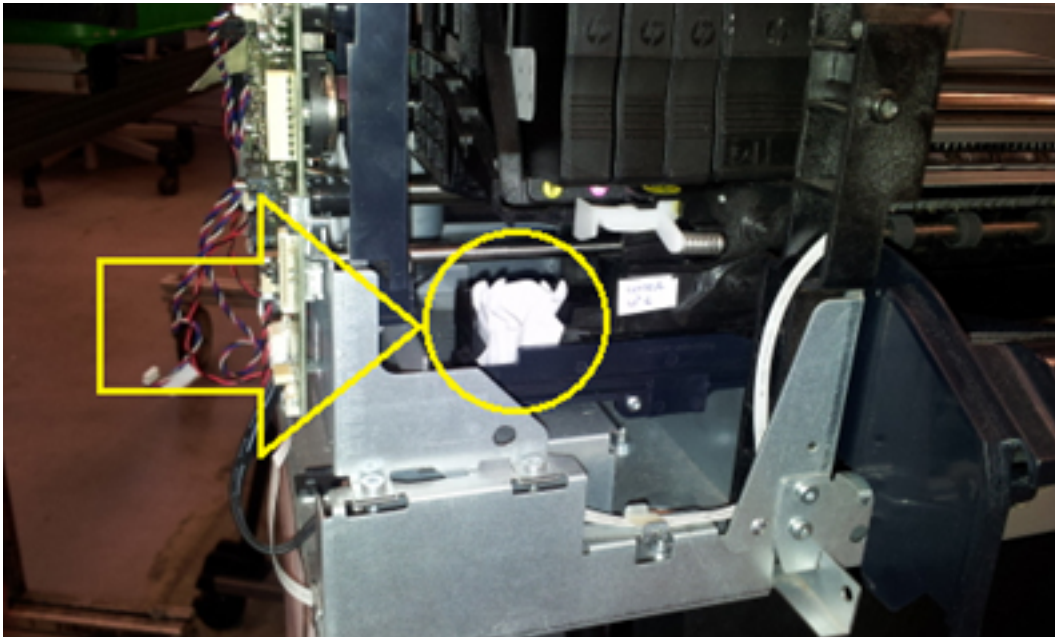

- If this does not solve the issue, arrange a service engineer visit to replace the cutter assembly.

### Onsite troubleshooting

The service engineer should first follow the paper troubleshooting in the user's guide, and also the instructions in this manual given to the customer by the call agent, to double-check that the troubleshooting has been done correctly. In most cases the problem can be solved by following these instructions. However, if the problem persists, try the following steps:

1. If the cutter is not engaged, check that the cutter bridge is well assembled.

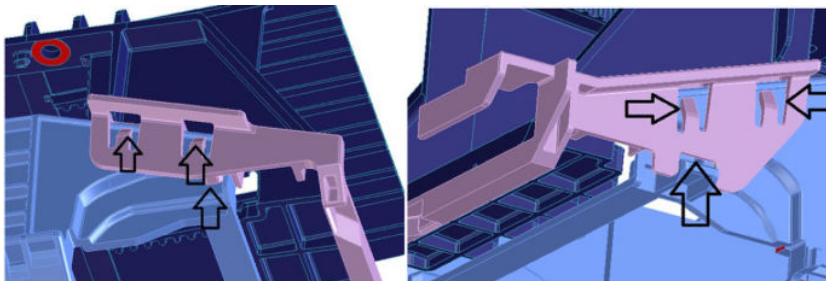



2. Check the cutter spring is in place.

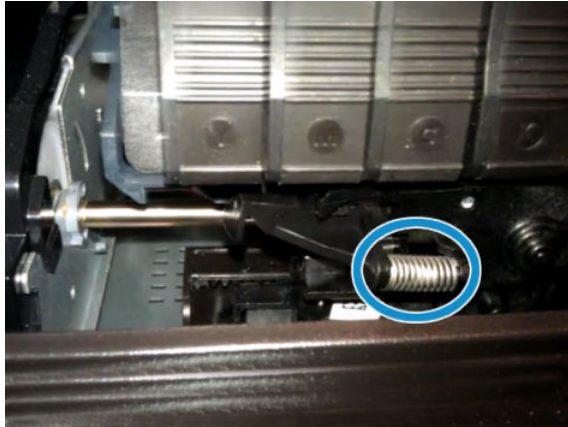

3. If the cutter bridge is well assembled and the cutter is not activated while cutting, the cutter assembly should be changed..
4. Check whether there is noise due to high friction during the cut. If this occurs, the cutter assembly should be changed. The high friction could be due to one of the following circumstances:
  - a. Worn-out blades as a consequence of many cuts.
  - b. Dirty blades. Likely to hold some sticky glue after cutting vinyl.
  - c. Hard points in blades. Whenever the cutter has suffered an impact, such as falling onto the floor, the blades mark themselves creating a hard point.
  - d. Excessive friction in the mechanism of the cutter.

## Paper has jammed

### Remote troubleshooting

- Check that the customer has followed the paper troubleshooting procedures described in the user's guide. If not, help him or her to do it.
- If the jam occurs with roll or single sheet, check with the customer that the output tray is closed. The printer does not allow printing or loading roll or single sheet with the Output Tray open (a message appears on the Front Panel). However if this is the case it is likely that the Output Tray Sensor is broken. Ask the customer to run the Output Tray Sensor diagnostics (see [4.6 Output Tray Sensor on page 191](#)). If the diagnostics fail, arrange a service engineer visit to replace the Output Tray Sensor (see [Output Tray Sensor Assembly on page 395](#)).
- If the jam occurs with roll, and the output tray is closed, check with the customer whether the jam occurs at the beginning of the print, because due to the paper curling the paper is stopped into the Output Tray (does not fall into the basket), provoking a paper jam. If this is the case, check with the customer whether the ribs in the Output Tray have risen or not. If these ribs are not up while printing from roll, it can cause paper jams at the beginning of the plot. If this is the case, arrange a service engineer visit to replace the Output Tray.
- If the problem persists it is probably a mechanical problem that should be diagnosed by a service engineer. Arrange a service engineer visit to diagnose the issue.

### Onsite troubleshooting

The service engineer should first follow the paper troubleshooting in the user's guide, and also the instructions in this manual given to the customer by the call agent, to double-check that the troubleshooting has been done correctly. In most cases the problem can be solved by following these instructions. However, if the problem persists, remove the covers and try the following steps:

1. Check that all the Pinchwheels are all present and well assembled; check also that all the pinchwheel springs are in place.

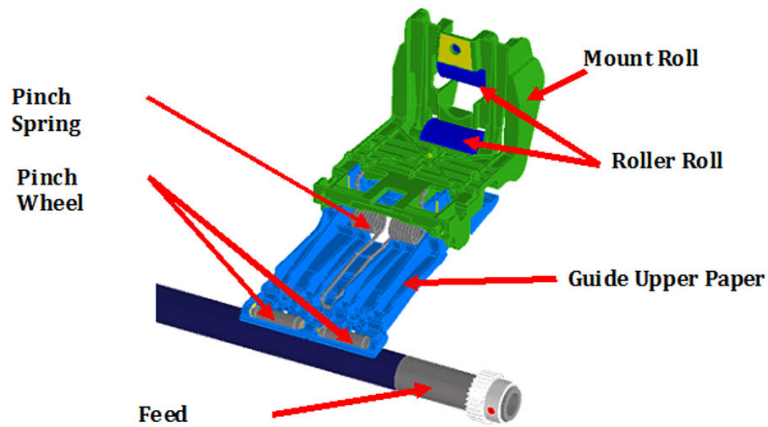

2. Check that the starwheel rail is correct.
3. Check that the spindle is not broken or inserted incorrectly, and that the spindle gear is OK.

# Communication troubleshooting

Please follow these suggestions to diagnose remote communication issues.

## General troubleshooting

1. Check the following symptoms:
  - The front-panel display does not show the **Printing** message when an image has been sent to the printer.
  - The computer displays an error message instead of printing.
  - The computer or printer hangs (stays idle), while communication is taking place.
  - The printed output shows random or inexplicable errors (misplaced lines, partial graphics, etc.).
2. To solve a communication problem:
  - Ensure that the correct printer has been selected in the application.
  - Ensure that the printer works correctly when printing from other applications.
  - Remember that very large prints may take some time to receive, process, and print.
  - If the printer is connected to a network, check the printer connectivity status: the printer should have an IP address and it should match the IP address specified in the printing computer. If the addresses do not match, then configure it correctly; if the issue persists, check the network configuration.
  - Try WiFi.
  - If the printer is connected to a wireless network, try moving the printer closer to the wireless router. Alternatively, try connecting the printer by network.
  - If the printer is connected to a wireless network, you can request a diagnostic report from the front panel: Scroll down the dashboard and press **⏏**, then scroll down the menu and press **Network Set Up > Print Reports > Wireless Test Report**. Alternatively, try moving the printer closer to the wireless router, or try connecting the printer by wired network.

When a network device automatically configures itself by receiving an IP address from the DHCP service, this IP address may change from the last time the device is powered off to the next time it is powered on, which may lead to the device being shown as "offline" when driver port settings are configured with the original IP address. There are at least three possible ways to avoid this:

- Increase the lease time of the DHCP server device.
- Set a fixed IP address for the printer so that it will not change by DHCP.
- Configure the printer and driver to refer to the hostname instead of the numeric IP address.

## Wired network issues

- ▲ If the HP software provided with the printer cannot be installed, check that:
  - All cable connections to the computer and the printer are secure.
  - The network is operational and the network hub is turned on.

- All applications, including virus protection programs, spyware protection programs, and firewalls, are closed or disabled for computers running Windows.
- The printer is installed on the same subnet as the computers that use the printer.

If the installation program cannot discover the printer, print the Network Configuration Page, and enter the IP address manually in the installation program.

Although assigning a static address to the printer is not recommended, some installation problems (such as a conflict with a personal firewall) may be resolved by doing so.

### Network port created does not match printer IP address (Windows)

If the computer is running Windows, make sure that the network ports created in the printer driver match the printer's IP address.

1. Print the printer's Network Configuration Page.
2. From **Start > Set up**, and then click **Printers** or **Printers and Faxes**. - or - From **Start > Front Panel**, and then double-click **Printers**.
3. Right-click the printer icon, click **Properties**, and then click the **Ports** tab.
4. Select the TCP/IP port for the printer, and then click **Configure Port**.
5. Compare the IP address listed in the dialog box and make sure it matches the IP address listed on the Network Configuration Page. If the IP addresses are different, change the IP address in the dialog box to match the address on the Network Configuration Page..
6. Click OK twice to save the settings and close the dialog boxes.

### Wireless network issues

1. Make sure the wireless (802.11) light at the top left of the front panel is turned on .

If the blue light is not lit, the wireless capabilities may not have been turned on. Swipe down the dashboard and press , then scroll down the menu and press **Network Set Up > Wireless Settings > On**.

2. Make sure that an Ethernet cable has not been connected to the printer. Connecting an Ethernet cable turns off the printer's wireless capabilities.
3. Restart components of the wireless network.

Turn off the router and the printer, and then turn them back on in this order: the router first, and then the printer. Then run the Wireless Setup wizard in the front panel and select your network. If you still are unable to connect, turn off the router, printer, and computer. Sometimes, turning off the power and then turning it back on recovers a network communication issue.

4. Run the Wireless Network Test.

For wireless networking issues, run the Wireless Network Test. To print a Wireless Network Test page, scroll down the dashboard and press , then scroll down the menu and press **Network Set Up > Print Reports > Wireless Test Report**. If a problem is detected, the printed test report includes recommendations that could help to solve the problem.

5. If required, print the Network Configuration Page to check deep network status information.



**NOTE:** The wireless connection can be affected by the location of the network router and the device. In order to improve your wireless connection:

1. If possible, try to position the wireless access point in a more central position of the office as shown in figure no 2 below. Try and place away from dense materials; metal, concrete, double thick walls are the hardest to penetrate, wood and plasterboard are easier. Consider these when positioning your printer.
2. Change the wireless channel to one that's not being used preferably; 1, 6 or 11 as these are non overlapping channels.
3. Extend the range of the wireless network by using a simple wireless extender or adding more wireless access points as shown in figures 3 and 4 below.

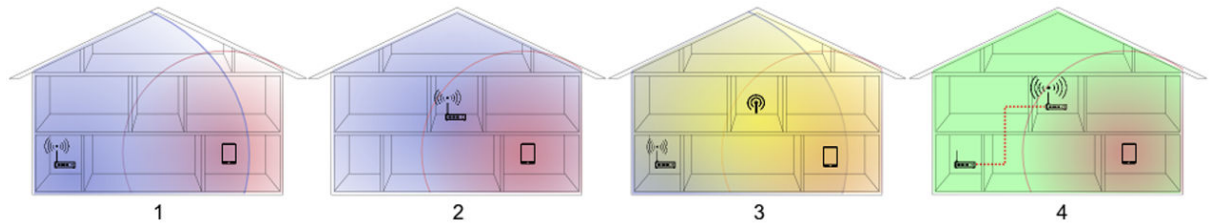

### Wireless Network Troubleshooting Report

1. Print the Wireless Network Troubleshooting Report (WNTR). From the front panel: Swipe down the dashboard and press , then scroll down the menu and press **Network Set Up > Print Reports > Wireless Test Report**.

This report consists of a top-level assessment of whether any wireless connection problems exist between the printer (STA) and the home network's wireless router, followed by more detailed sections showing the result of various diagnostic tests as well as a configuration summary.

**ATTENTION** Your HP printer is unable to connect to your wireless router.

- SOLUTION**
- 1 Check that your wireless router is powered on.
  - 2 Check that your HP printer network name (SSID) matches your wireless router network name (SSID) exactly.
  - 3 If they do not match exactly, run the Wireless Setup Wizard to configure your HP printer.

**DIAGNOSTICS RESULTS**

<b>&gt; Wireless</b>	
-- Wireless On	PASS
-- Wireless Working	PASS
-- Signal Quality	Not Run
<b>&gt; Connectivity</b>	
-- Connected	Not Run
-- Disconnect count total	12
-- Disconnect count (last hour)	5
-- Disconnect count (last 24 hours)	5
<b>&gt; Network</b>	
-- Network Name (SSID) Found	FAIL
-- Other networks detected matching your network name (SSID)	Not Run
-- Wireless Networks Detected	16
<b>&gt; Settings</b>	
-- Printer Settings Consistent with Wireless Router Settings	Not Run
-- No Filtering	Not Run
-- Channel	Not Run
-- Security	Not Run

**CURRENT CONFIGURATION**

-- Network Name (SSID)	XXXXXXXXXXXX XXXXXXXXXXXX XXXXXXXXXXXX
-- Hardware Address (MAC)	02:ba:d0:03:07:0e
-- IP Address	Not applicable
-- Configuration Source	Not applicable
-- Communication Mode	Infrastructure
-- Authentication Type	Open System
-- Encryption	64-bit WEP
-- Internet	Not applicable

For additional help with troubleshooting, refer to the network troubleshooting help section provided with your HP printer.  
For more information on your network configuration, print the Network Configuration Page.  
Visit the HP Wireless Printing Center - [www.hp.com/go/wirelessprinting](http://www.hp.com/go/wirelessprinting).

For more information about the contents of the Wireless Network Troubleshooting Report, see [Wireless troubleshooting report error cases on page 549](#). There is only one situation that requires on-site repair: when the Wireless PCA is defective. To replace the Wireless PCA, you must replace the Main PCA; see [Main PCA on page 311](#).

2. If you are not using a unique network name (SSID), then it is possible that the computer could be connected to the wrong network. See [How to check whether your computer is connected to your network on page 546](#).

## Network Configuration Page

1. Make sure that the computer's wireless networking has been turned on. For more information, see the documentation that came with the computer.

- Print the **Network Configuration Page**. From the front panel: press , then **Internal Prints > User Information Prints > Network Configuration Page**.

This contains important wireless configuration information at a glance for the user and call agents. Detailed configuration and status information is also included, such as MAC address, wireless channel and signal strength, IP settings, Ports/Services status, and a list of wireless networks in range of the printer. The Network Configuration Page contains important details for Wireless Direct including SSID name, IP address and security pass code.

### HP Network Configuration Page

---

#### General Information

Network Status	Ready
Active Connection Type	None
URL(s) for Embedded Web Server	http://HP23478E http://192.168.0.92 http://192.168.223.1
Firmware Revision	MUL2FA1049BR
Hostname	HP23478E
Serial Number	CN08O2V51805MQ

---

#### 802.11 Wireless

Hardware Address (MAC)	02:ba:d0:23:47:8e
Status	Connected
Communication Mode	Infrastructure
Network Name (SSID)	Betalab-CSat
Access Point HW Address	00:24:a8:9b:6e:f3
Signal Quality (1 – 5)	5
Channel	1
Authentication Type	WPA-PSK
Encryption	Automatic (AES or TKIP)

#### IPv4

IP Address	192.168.0.92
Subnet Mask	255.255.255.0
Default Gateway	192.168.0.1
Configuration Source	DHCP
Primary DNS Server	209.18.47.61
Secondary DNS Server	209.18.47.62
Total Packets Transmitted	171
Total Packets Received	1948

## Manual driver installation

If there are issues installing the drive with the installer provided, follow these steps for manual set up:

1. Connect printer to the PC.
2. Unzip the driver package in the Config folder > Drivers:
  - X64 folder for 64-bit OS [hpi51cax.inf]
  - X86 folder for 32-bit OS [hpi51cah.inf]

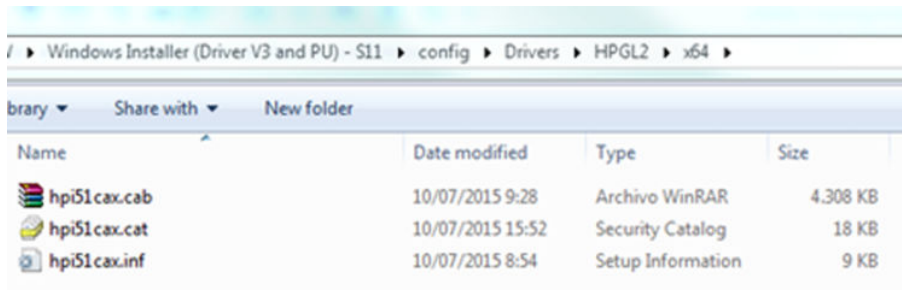

3. Open the **Print Management Console** (In the Start menu, type “printmanagement.msc” -> In the **Print Management Console**, go to Print Servers/Local):

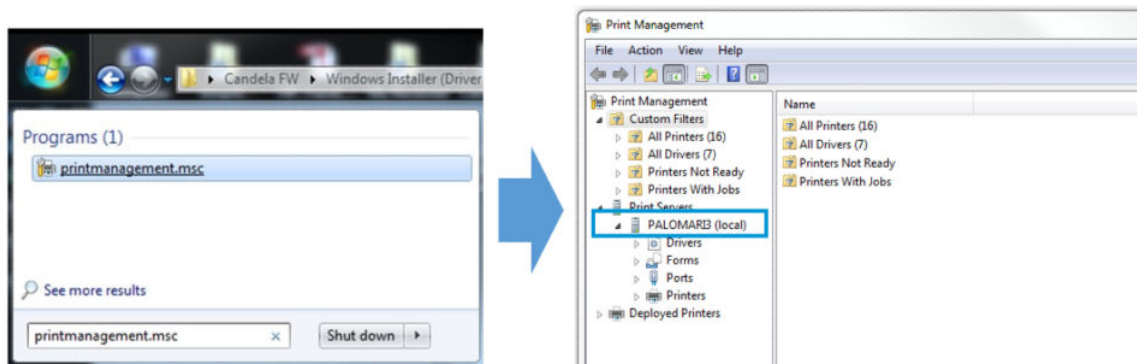

In order to set up the driver for the printer, required are; one driver, one port, and one printing queue.

1. **Driver Set Up:**
  - a. Select the drivers section and right click on a blank area.
  - b. Select **Add Driver**.
  - c. Follow the steps.
  - d. Select “**Have Disk...**”.
  - e. Browse to the location of the driver.



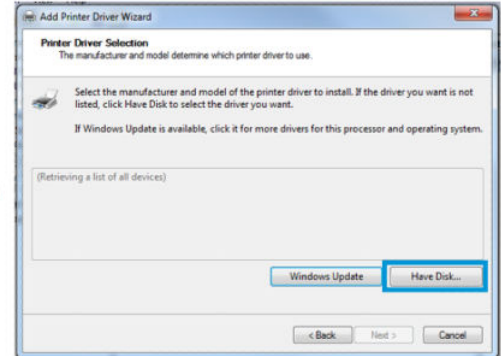
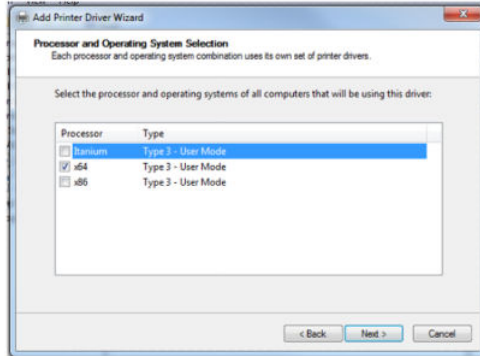
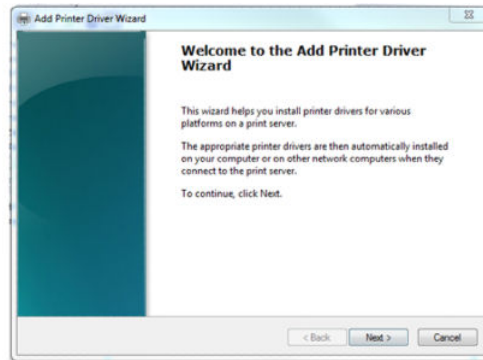
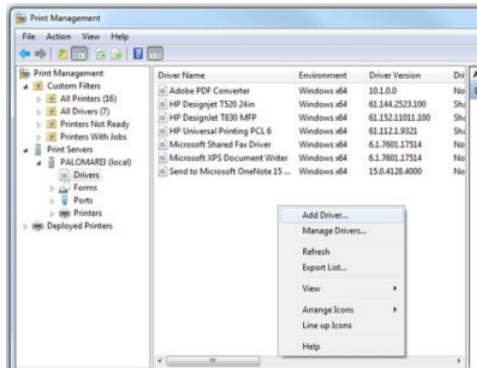

## 2. Port Set Up:

Select port section and right click on a blank area “Add Port...”

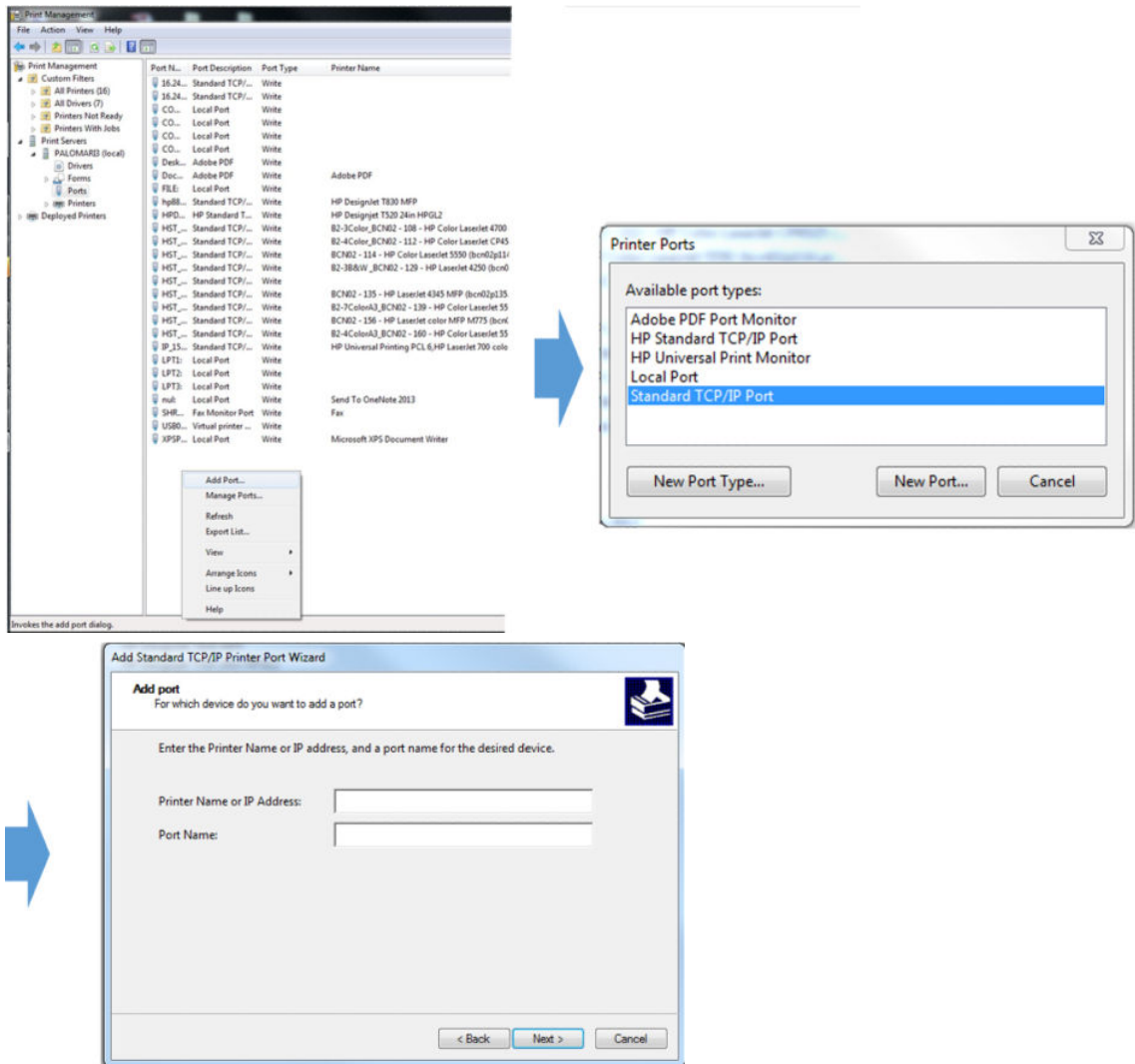

### 3. Printer/Printing Queue Set Up:

Select port section and right click on a blank area “Add Printer...”

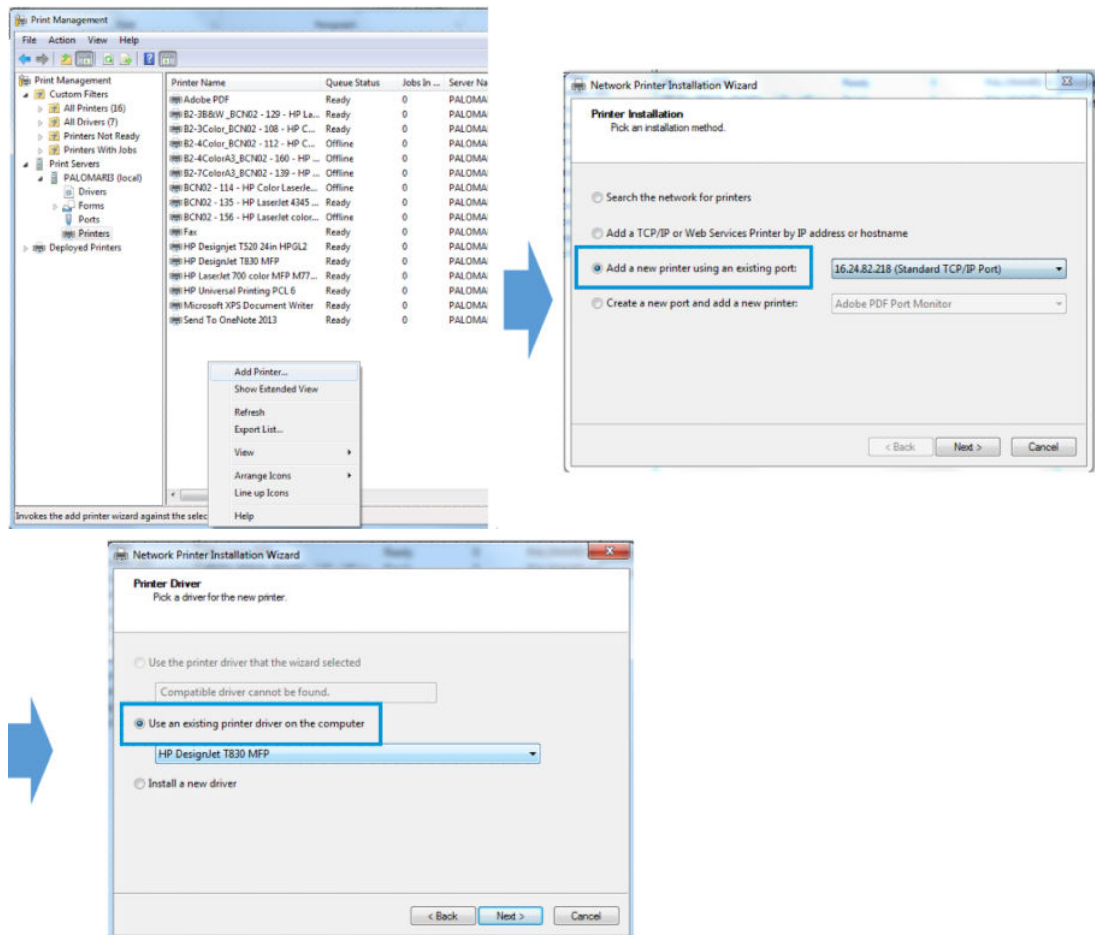

## Drivers Troubleshooting

When reporting a customer issue, it is very important to have the following information:

- Printer Model
- Operating system version (Client/Server?)
- Driver version
- Application causing problems and version
- Full list of driver settings used
- Killer plots
- PRN

Driver version is obtained from: “**Devices and Printers**”:

1. Right-click on the printer.
2. Select “**Printer properties**”.
3. Go to the “**About**” tab.

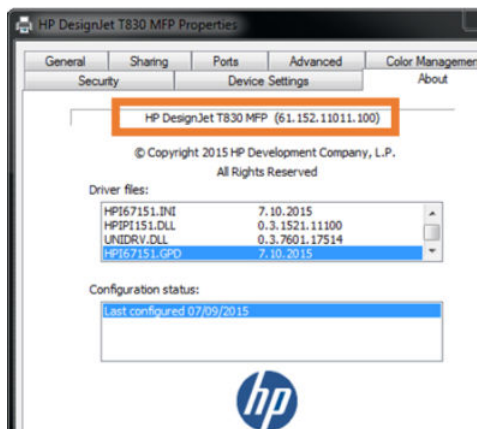

The PRN is a file containing driver information generated before the spooler sends it to the printer.

1. From “**Devices and Printers**”, right-click on the printer and select “**Printer properties**” and then go to the “**Ports**” tab.
2. Click “**Add Port**”, select “**Local Port**” type and “**New Port**”, and enter the full path (including file name) where the PRN will be generated, for example:

- C:\Users\\Desktop\hpgl2\_issue.prn

After creating the new port, it will be assigned to the Printer Queue automatically.

---

 **NOTE:** Every time the user prints to this printer, a PRN file will be generated with the driver’s job information.

---

**Table 2-1 Driver features**

Feature	V3 : discrete and UPD ( W7, W8 and W8.1 ) - HPGL2	V4 (W8 and W8.1) - PCL3GUI	V4 Class Driver - PCL3GUI	MacOS- PCL3GUI
Document Size ( A4, A, ...)	X	X	X	X
Margins: STD, Oversize, Clip content by margins	X	X		X
Custom page size	X	OS	OS	X
Paper Source: Tray, Roll, Manual feed	X	X	X	X
Paper type: Actual media types, not Generics	X	X		X
Quality: Fast / Normal / Best	X	X	X	X
Economode	X	X	X	X
Max detail	X	X		X
Resize: % , Fit to ...	X	X		OS
Disable cutter	X	X		X
Remove top/bottom blank areas	X	X		X
Remove margins between pages	X			
Rotate 90 degrees	X	X		
Autorotate	X	X		
Print on Color/Mono/Grayscale	X	X		X
Color management: Application/Printer (sRGB/AdobeRGB/Printer Emulation)		HP DesignJet 500/800 series HP DesignJet 100 series		
Send job as bitmap	X			
Max Application resolution	X			
Resolution managed by application	X			
Page order: Front to Back, Back to Front	X	X		OS
Orientation in 'Auto Select': Short edge first/Defined by document	X			
Bi-directionality	X	X		X
Copies	X	X	X	OS
Collate	X	X		OS

# Ink-supplies troubleshooting

## Ink cartridges

**Table 2-2 Available Ink Cartridges**

Ink cartridge	Part number
HP 728 69 ml Black Ink Cartridge	F9J64A
HP 728 40 ml Cyan Ink Cartridge	F9J63A
HP 728 40 ml Magenta Ink Cartridge	F9J62A
HP 728 40 ml Yellow Ink Cartridge	F9J61A
HP 728 300 ml Black Ink Cartridge	F9J68A
HP 728 130 ml Cyan Ink Cartridge	F9J67A
HP 728 130 ml Magenta Ink Cartridge	F9J66A
HP 728 130 ml Yellow Ink Cartridge	F9J65A

All ink cartridges are compatible with the T730 and T830.

## Replace an ink cartridge

There are two occasions when you need to replace an ink cartridge:

- The ink cartridge is very low and you want to replace it with a full cartridge for unattended printing (you can use up the remaining ink in the first cartridge at a more convenient time).
- The ink cartridge is empty or faulty, and you must replace it to continue printing.

**⚠ CAUTION:** Do not try to remove an ink cartridge while printing.

**CAUTION:** Remove an ink cartridge only if you are ready to insert another one.

1. Make sure the printer is turned on.
2. Open the ink cartridge cover on the rear right-hand side of the printer.



3. Remove the ink cartridge.

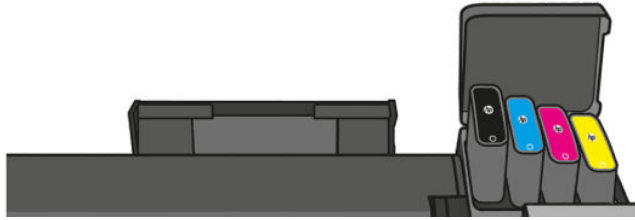

4. Insert the new ink cartridge. Make sure that you insert the ink cartridge into the slot that has the same colored letter as the cartridge you are installing.

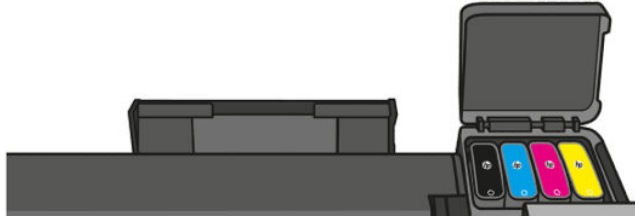

5. Close the ink cartridge cover.

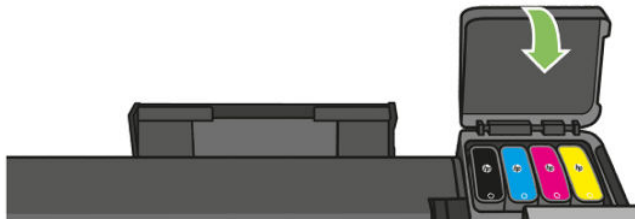

## Ink cartridge status

To view the ink levels of your ink cartridges, touch the **Dashboard status** on the front panel and touch .

Touch the desired ink level for more information.

You can also get this information from the HP Utility.

- In the HP Designjet Utility for Windows, go to the **Supplies** tab to see each cartridge's status.
- In the HP Utility for Mac OS X, select **Supplies Status** in the Information group.

For an explanation of the ink cartridge status messages, see [ink cartridge status messages on page 123](#).

If you touch **Replace Inks**, the printer will give you step-by-step instructions to replace the ink cartridges. See [Replace an ink cartridge on page 122](#) for more information.

## Ink cartridge status messages

To check the status of ink cartridges, see [ink cartridge status on page 123](#).

These are the possible ink cartridge status messages:

- **OK:** The cartridge is working normally, with no known problems.
- **Missing or Damaged:** There is no cartridge present, or it is not correctly connected to the printer (shown with an X on the status screen).
- **Low:** The ink level is low.
- **Out of ink:** The cartridge is empty.
- **Non-HP ink cartridges installed:** The cartridge is not a genuine HP cartridge.
- **Incompatible:** The cartridge is incompatible with this printer.

## Solving ink-supply problems

Most of the problems that you may encounter when working with the ink supplies are solved with guidance from the Front Panel. A full list of Front Panel messages is supplied in the user's guide.

### You cannot insert the Ink Cartridge

1. Check that you have the correct type of cartridge (model number). See [Table 2-1 Driver features on page 121](#).
2. Check that the colored label on the cartridge is the same color as the label on the slot.
3. Check that the cartridge is correctly oriented, with the letter or letters marking the cartridge label right-side up and readable.

---

 **CAUTION:** Never clean inside the ink cartridge slots.

---

## Printhead

The printhead is extremely durable and does not need to be replaced every time an Ink Cartridge is replaced. It is independent of the Ink Cartridges and will continue giving excellent results even if the Ink Cartridges are low on ink.

**Table 2-3 Available printheads**

	Part number
Printhead Host	F9J56A
HP 729 Printhead Trade Replacement Kit	F9J81A

## Replace the printhead

 **TIP:** When the printhead has been replaced, the printer will automatically perform a printhead alignment on the loaded paper. If you would like to perform the printhead alignment on a different paper (perhaps from the multi-sheet tray), you could change the paper before starting this procedure. Plain white paper is recommended.

**TIP:** Wear cotton gloves to avoid transferring oils onto the paper.

---



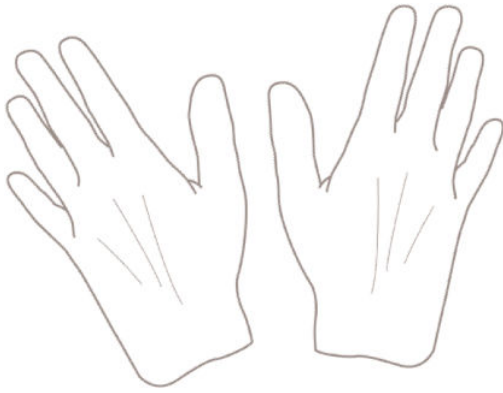

 **NOTE:** It is recommended to use the supplies provided with the printhead kit. Before starting this process make sure the inserted print cartridges contain enough ink. In case there is not enough ink, the printer will request new cartridges. See [Replace an ink cartridge on page 122](#).

1. Make sure the printer is turned on.
2. Make sure the printer wheels are locked (the brake lever is pressed down) to prevent the printer from moving.
3. From the front panel, go to the dashboard status, touch , scroll to Printer maintenance and select the **Replace Printhead** option. Follow the instructions on the control panel.
4. When requested on the front panel, open the printhead door on the right hand side of the printer.

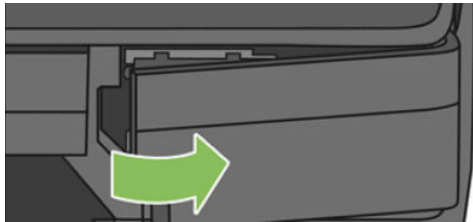

5. Locate the tubes connector lever (blue) to release the ink tubes.



6. Raise the blue lever to release the tube connector and store the tubes connector on the tubes connector holder in the printer door.

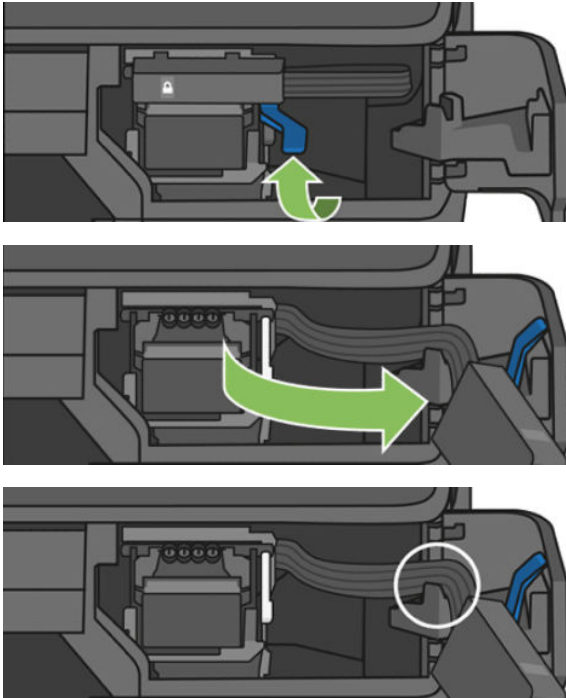

7. Locate the printhead lever (white).

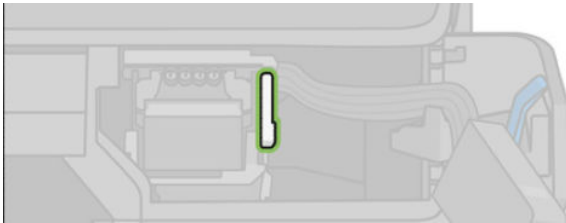

8. Raise the lever to release the carriage.

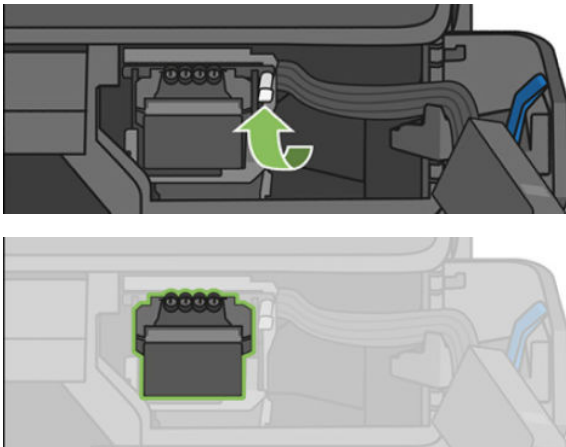

9. Remove the printhead. Handle it with care to avoid getting ink on the connections.

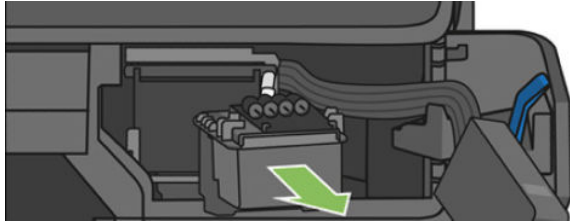

10. Insert the new printhead.

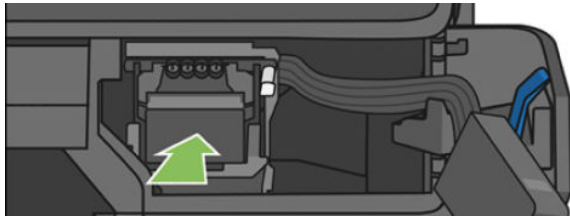

11. Lower the printhead lever (white).

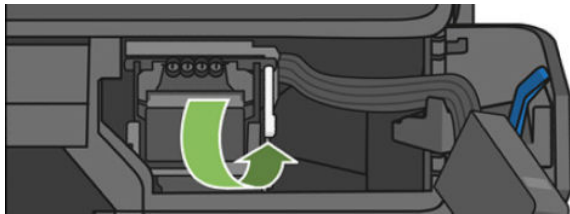

12. Insert the tubes connector into the printhead.

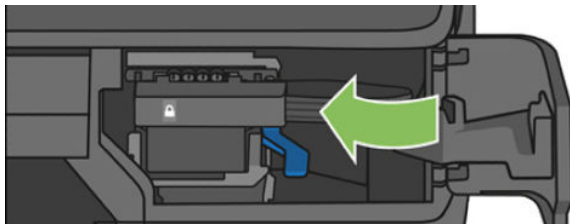

13. Make sure it locks.

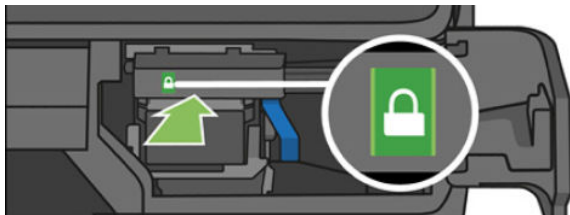

14. Close the door and follow the instructions on the front panel.

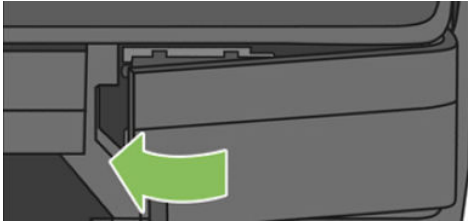

15. The front panel recommends a printhead alignment.

The Printer now prepares the printhead for use. The process takes approximately 6 minutes.

 **IMPORTANT:** Do not open any covers during this process.

### You cannot insert the printhead

1. Check that you have the correct type of printhead (HP no. 729). See [Table 2-1 Driver features on page 121](#) to check corresponding model number.
2. Check that you have removed the orange protective cap from the printhead.
3. Check that the printhead is correctly oriented.

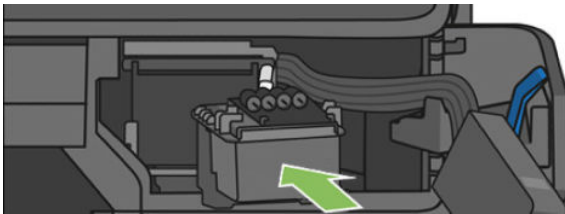

4. Check that you have correctly latched the printhead (white latch), see [Replace the printhead on page 124](#).



5. Check that the printhead is correctly inserted.
6. Check that the tubes connector lever (blue) is up before connecting the tubes connector.

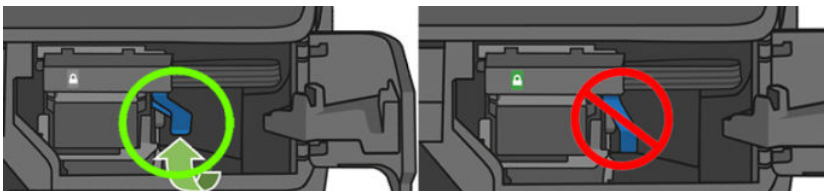

## Clean the printhead

If your print is streaked or has incorrect or missing colors, the printhead may need to be cleaned.

There are three stages of cleaning. Each stage lasts about two minutes, uses one sheet of paper, and uses an increasing amount of ink. After each stage, review the quality of the printed page. You should initiate the next phase of cleaning only if the print quality is poor.

If print quality still seems poor after you complete all stages of cleaning, try aligning the printhead.

---

 **NOTE:** Cleaning uses ink, so clean the printhead only when necessary.

 **NOTE:** Failing to turn off the printer correctly can cause print-quality problems.

---

### Clean the printhead from the front panel

1. Make sure there is paper in the input tray or a roll loaded.
2. Go to the front panel and touch , then **Image Quality Maintenance > Clean printhead**.

### Clean the printhead from the Embedded Web Server

1. Make sure there is paper in the input tray or a roll loaded.
2. In the **Tools** tab of the Embedded Web Server, select **Print Quality Toolbox > Clean Printhead**, and follow the instructions on the screen.

### Clean the printhead from the HP Utility

1. Make sure there is paper in the input tray or a roll loaded.
2. **Windows:** In the **Support** tab of the HP Utility, select **Printhead Cleaning**, and follow the instructions on the screen.
3. **Mac OS X:** In the **Information and Print Quality** tab of the HP Utility, select **Clean Printhead**, and follow the instructions on the screen.

## Align the printhead

Precise printhead alignment is essential for accurate colors, smooth color transitions, and sharp edges in graphical elements. Your printer has an automatic printhead alignment process which runs whenever a printhead has been accessed or replaced.

You may need to align the printhead after a paper jam or if you are experiencing problems with color accuracy.

To align the printhead, ensure that paper is loaded, then press , then **Image Quality Maintenance > Align printhead**.

---

 **CAUTION:** Do not use transparent or semi-transparent paper to align the printhead.

---

## Printhead troubleshooting

A printhead failure will be reported with the following message:

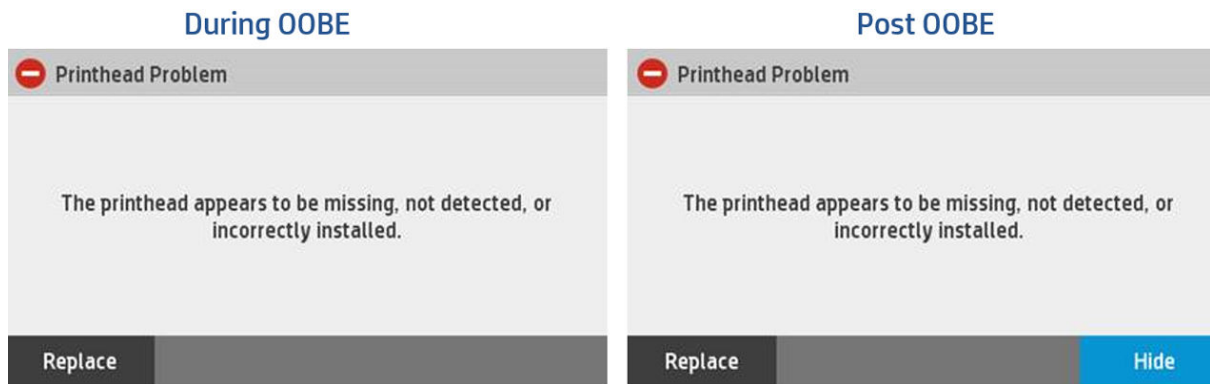

Press the [Replace](#) button to enter the replace routine and cut electrical power to the printhead.

1. Remove the printhead and check electrical contacts for damage or dirt.
2. Reseat the printhead and try again.

Further information can be obtained from the error log. System Errors for the printhead are not explicitly shown in the Front Panel. This can give information about a failure in the printhead, if the printhead is missing, or if the wrong part is being used (T120&T520 printhead).

3. If the System Error log points to a printhead failure proceed to replace the printhead.
4. If the error persists, then the carriage with the trailing cables should be replaced.

### Error messages related with printhead and start-up

- “The printhead appears to be missing, not detected, or incorrectly installed.”
  - An error in the printhead was detected.
  - How to solve: replace the printhead.
  - In the error log, this is encoded using error codes 0027-XXXX.
- “A new, un-used printhead is needed.”
  - The tubes are empty but the printhead is full; the only way to fill the tubes is by using an empty (new) printhead.
  - How to solve: replace the printhead.
- “The printer has detected an error. Restart the printer and retry the operation. If the problem persists, call HP support. Error code: XXXX-XXXX.”
  - 0021-0161: Priming motor or electrical failure.
  - 0021-0180: Air Leak in Priming system.
  - 0021-0132: Weak Primer motor or underpowered motor.
  - 0024-0000: PHA startup failed due to ink blockage after retrying twice.
- “An error occurred and the printhead start-up failed. Contact HP. Error code: XXXX-XXXX.”

- 0024-1100: IDS startup failure due to ALTERED supplies OOI.
- 0024-1000: IDS startup failure due to supplies OOI, or leaky tubes or supplies.
- “The printhead needs to be resealed. Open the door on the right to access printhead.”
  - Bad connection of the tubes with the printhead. May happen once during startup before showing a system error.
  - User should just follow instructions.

Other system errors related with the PHA startup that may appear in the error log:

- 0824-0100: IDS startup detected no ink flow during the long repumps phase.
- 0824-0200: IDS startup detected no ink flow during the delays phase.
- 0824-0300: IDS startup detected no ink flow during the bag cycling phase.
- 0824-2000: SHAID was not covered during IDS startup.

## Safe Stop: printer behavior in the face of a Continuous Ink System

HP Designjet T730 & T830 MFP, and all new DesignJet printers, will include this feature to detect when unsupported supplies are used in the unit: the printer expects a supply with finite volume, and after an expected ink volume is extracted from the supply, an Out of Ink event must happen. If this event does not happen, the printer evaluates that the customer is using a continuous ink system.

If customers are using a continuous ink system, the printer will show the following message:



There are comments included in the User guide to inform the customer about this unsupported operation:

- *The printer is not designed to use continuous ink systems. To resume printing, remove continuous ink system and install genuine HP (or compatible) cartridges.*
- *This printer is designed for ink cartridges to be used until they are empty. Refilling cartridges prior to depletion might cause your printer to fail. If this happens, insert a new cartridge (either genuine HP or compatible) to continue printing.*

There is also a clause in the warranty statement where this is clearly stated:

- *5. HP's limited warranty is void in the event the printer is attached to an aftermarket apparatus or system that modifies the printer's functionality such as a continuous ink system.*

In the event the customer is using a continuous ink system:

- Do not replace cartridges under warranty. (Instruct customer to replace the incompatible cartridges with HP or compatible cartridges.)
- **Do not replace or repair the printer under warranty!**
- This error can also occur when customers refill supplies, never allowing them to become depleted.

**The following messages are proposals of communication from Call Agent to Customer:**

- "This printer is not designed to use continuous ink systems. To resume printing, remove continuous ink system and install genuine HP (or compatible) cartridges."
- "This printer is designed for ink cartridges to be used until they are empty. Refilling cartridges prior to depletion might cause your printer to fail. If this happens, insert a new cartridge (either genuine HP or compatible) to continue printing."
- "HP's limited warranty is void in the event the printer is attached to an aftermarket apparatus or system that modifies the printer's functionality such as a continuous ink system."



# Print-quality troubleshooting

## General print-quality troubleshooting

These procedures should help with streaked or faded prints, prints without black or other colors, prints with blurred or fuzzy text, prints with ink streaks or smears, and many other problems.

Try the following solutions in the order presented in order to resolve the common issues described above. When one of the solutions resolves the issue, there is no need to continue troubleshooting.

### Use genuine HP ink cartridges

- ▲ HP recommends that you use genuine HP ink cartridges. HP cannot guarantee the quality or reliability of non-HP cartridges. If you are not using genuine HP ink cartridges, the following solutions might not resolve your print-quality issue.

### Check the paper

- ▲ Make sure that the paper is appropriate for the print job.

### Check the print settings

- ▲ **Windows:** Open the Windows driver and go to the **Paper/Quality** tab. Adjust **Print Quality, Document Size, and Margins/Layout**.
- ▲ **Mac OS:** Open the Mac OS Print dialog and go to the **Paper/Quality** tab. Adjust **Quality Options, Paper Size, Format, and Margins/Layout**.

### Print and evaluate a print-quality diagnostic report and troubleshoot defects



---

**NOTE:** Never use demo plots to check image quality as they are optimized for settings that may not match the customer's scenario.

---

Use the following procedure to print, and then evaluate a print-quality diagnostic report.

1. Print a print-quality diagnostic page.
  - a. Make sure there is plain white, letter-size paper loaded in the sheet feeder at the back of the printer.
  - b. Choose the Multi-Sheet Tray (multi-sheet or single-sheet) from the front panel.

- c. Swipe down the dashboard and press , then scroll down the menu and press **Reports >.Print Quality Report**. The print-quality diagnostic page prints.

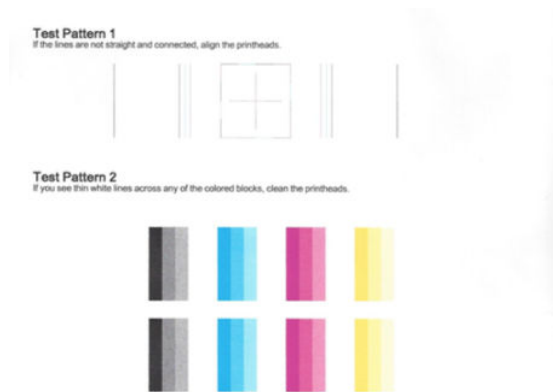

2. If the lines in Test Pattern 1 are not straight and connected, follow these steps to align the printer:
  - a. Make sure there is plain white, letter-size paper loaded in the sheet feeder on the back of the printer.
  - b. Swipe down the dashboard and press , then scroll down the menu and press **Printer Maintenance >.Align Printhead**. The printhead alignment procedure will begin.
  - c. At the end of the process a page prints, which may be discarded.
3. Examine the Test Pattern 2. Shown here is a good example of the test pattern.

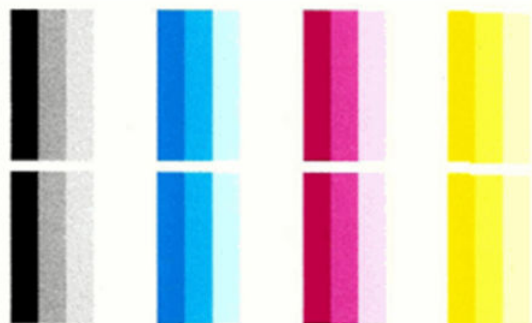

If any of the colored blocks in Test Pattern 2 show white lines, or are faded or missing completely, follow these steps to clean the printhead.

- a. Make sure there is plain white, letter-size paper loaded in the sheet feeder on the back of the printer.

- b. Swipe down the dashboard and press , then scroll down the menu and press **Printer Maintenance** > **Clean Printhead**. The printhead cleaning process will begin.

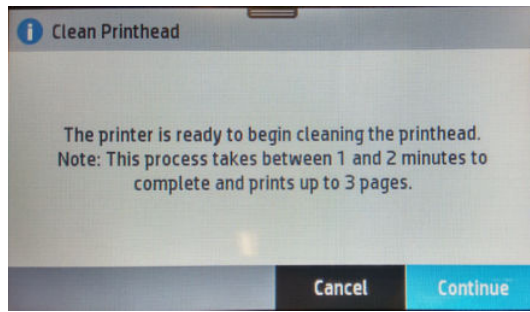

- c. At the end of the process a page prints. Examine that page to see if more cleaning is required.
- d. If there are defects on the page that prints after cleaning, try cleaning the printhead by pressing the Yes button on the Front Panel for second level cleaning. Repeat the cleaning for the third level cleaning if it is still not resolved.

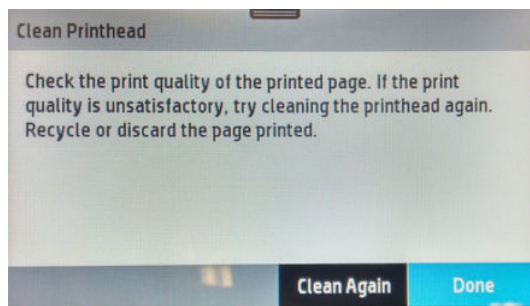

- e. If the problem is still not resolved after third-level cleaning, proceed to the next step (check print quality), before replacing the printhead.

---

 **NOTE:** To avoid problems that require printhead cleaning, always use the **Power** button to turn the printer off. Always replace any missing cartridges as soon as possible to avoid print-quality issues and possible extra ink usage or damage to the ink system. Never turn off the printer when the ink cartridges are missing.

---

### Check print quality

If you see no defects on the print-quality diagnostic report, you can double-check the print quality with the Diagnostic Image.

- a. Make sure there is plain white, letter-size paper loaded in the sheet feeder on the back of the printer.

- b. Press four times on the Back Key. The Support Menu will appear. Go to **4. Reports > 4.4 Agents Assisted Image Test.**

### AGENT-ASSISTED IMAGE TEST

#### Product and Revision Information

1. Serial Number: CN22M0M04C
2. Firmware Version: AXP1CN1226FR

#### Ink Delivery System Information

	Magenta	Cyan	Yellow	Black
3. Ink Supply:	0	0	0	0
4. SHAID Status:	2014/02/26	2013/12/17	2013/12/17	2014/01/01
5. End of Warranty Date (Y-M-D):	OK	OK	OK	OK
6. Warranty Status:				

#### Print Head Information

7. Total Drop Count (ml):	Magenta: 0.872	Cyan: 0.864	Yellow: 0.939	Black: 1.080
8. PHA Install Date:	2012/03/28			

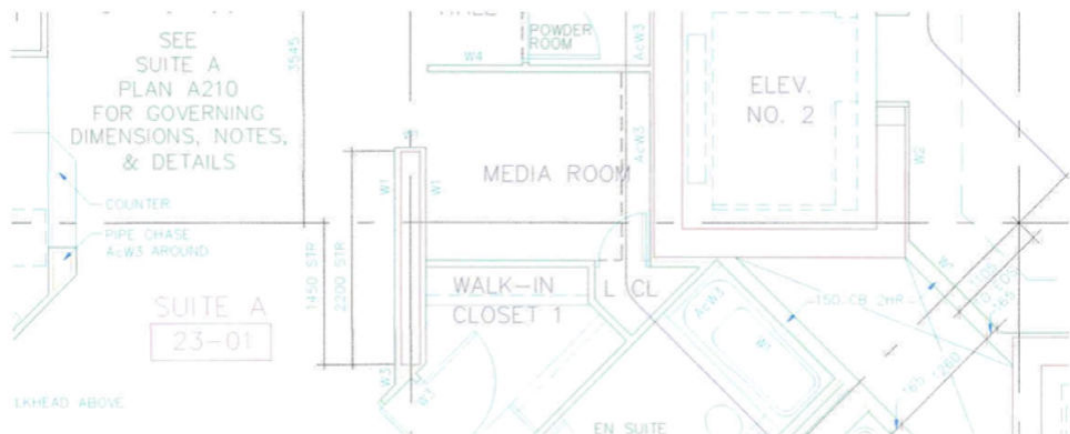

If the Agent Assisted Images both look OK, then the print mechanism and ink supplies are working correctly. Ask the customer to use a higher quality print mode.

#### Check ink supply station

Remove all ink cartridges and confirm movement of all the lifters, check the cartridges, and confirm bongos are not damaged or blocked.

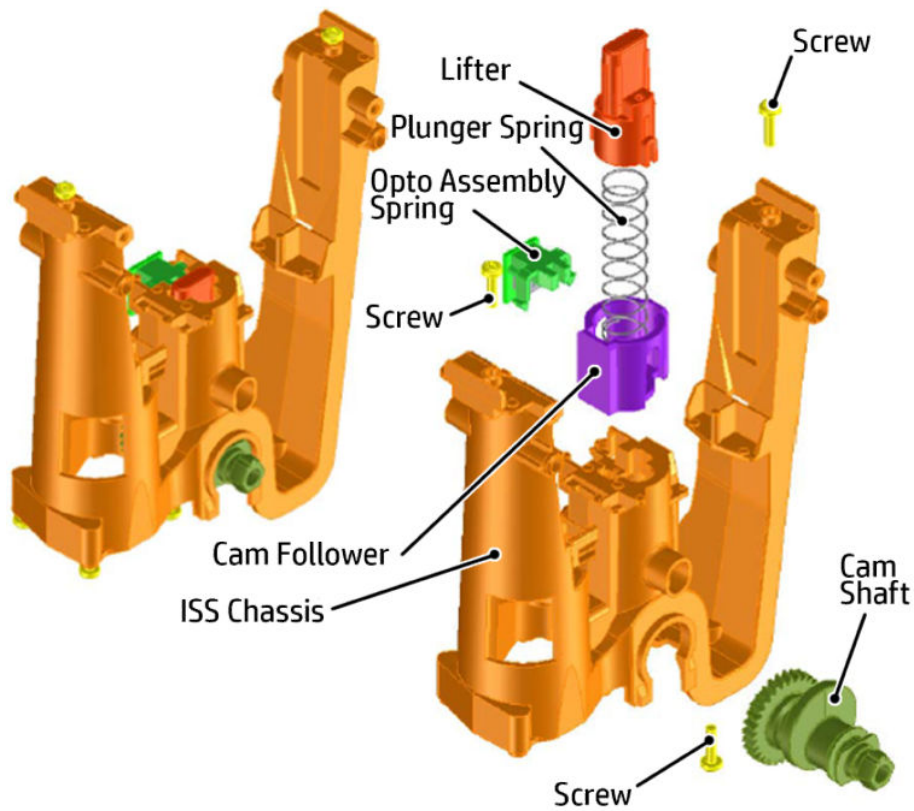

### Replace the problem ink cartridge

If none of the preceding steps resolved the issue, replace the cartridge that corresponds to the defect on the Print Quality Diagnostic report. For example, if the magenta color block is streaked and printhead cleaning does not help, replace the magenta cartridge, see [Replace an ink cartridge on page 122](#).

 **NOTE:** Use the Print Quality Diagnostic Page (not the Agent Assisted Image Test) to confirm failure before replacing ink cartridges or the printhead.

### Replace the printhead

If you have completed all of the troubleshooting steps and are still experiencing a problem, replace the printhead.



---

**NOTE:** Use the Print Quality Diagnostic Page (not the Agent Assisted Image Test) to confirm failure before replacing ink cartridges or the printhead.

---

### **Service the printer**

If the steps above have not solved the problem, service the printer.



---

**NOTE:** Keep a print sample that shows the problem. If the ink cartridges, printhead, or printer is replaced under warranty, the support agent will request the print sample. If the printer is returned to HP, the print sample must be returned with the printer. Place the sample in the output tray when you package your printer for shipping.

---

## **Print-quality defects**

- [Horizontal lines across the image \(banding\)](#)
- [Lines are too thick, too thin or missing](#)
- [Lines appear stepped or jagged](#)
- [Lines print double or in the wrong colors](#)
- [Lines are discontinuous](#)
- [Lines are blurred](#)
- [Line lengths are inaccurate](#)
- [The whole image is blurry or grainy](#)
- [The paper is not flat](#)
- [The print is scuffed or scratched](#)
- [Ink marks on the paper](#)
- [Black ink comes off when you touch the print](#)
- [Edges of objects are stepped or not sharp](#)
- [Edges of objects are darker than expected](#)
- [Vertical lines of different colors](#)
- [White spots on the print](#)
- [Colors are inaccurate](#)
- [Colors are fading](#)
- [The image is incomplete \(clipped at the bottom\)](#)
- [The image is clipped](#)
- [Some objects are missing from the printed image](#)
- [A PDF file is clipped or objects are missing](#)

## Horizontal lines across the image (banding)

If your printed image suffers from added horizontal lines as shown (the color may vary):



1. Check that the paper type loaded corresponds to the paper type selected in the front panel and in the software.
2. Check that the customer is using appropriate print-quality settings for the purpose. In some cases, you can overcome a print-quality problem merely by selecting a higher print-quality level. For instance, if you have set the Print Quality slider to **Speed**, try setting it to **Quality**.
3. Print the print-quality diagnostic report. See [General print-quality troubleshooting on page 133](#).
4. If the printhead is working correctly, perform paper advance calibration, see the user's guide.

If the problem persists despite all the above actions, contact your customer service representative for further support.

## Lines are too thick, too thin or missing

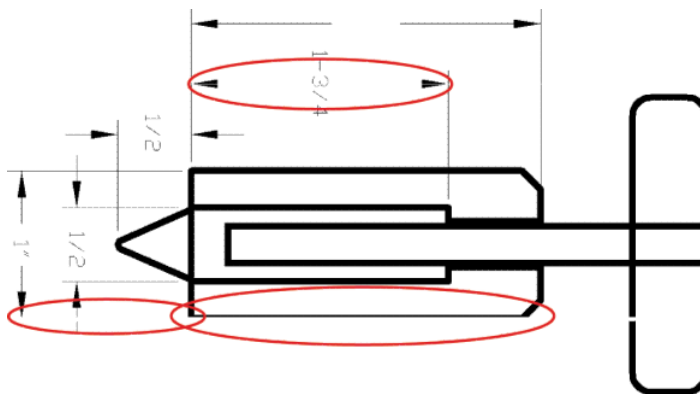

1. Check that the paper type you have loaded corresponds to the paper type selected in the front panel and in your software.
2. Check that you are using appropriate print-quality settings for your purposes. Select the custom print-quality options in the driver dialog, and try turning on the **Maximum detail** option (if available).
3. If the resolution of your image is greater than the printing resolution, you may notice a loss of line quality. You can find the **Max. Application Resolution** option in the driver dialog's **Advanced** tab, under **Document Options > Printer Features**.
4. If lines are too thin or missing, print the print-quality diagnostic report. See [General print-quality troubleshooting on page 133](#).

5. If the problem remains, align the printhead. See [Align the printhead on page 129](#).
6. If the problem remains, perform paper advance calibration, see the user's guide.

If the problem persists despite all the above actions, contact your customer service representative for further support.

### Lines appear stepped or jagged

If lines in your image appear stepped or jagged when printed:

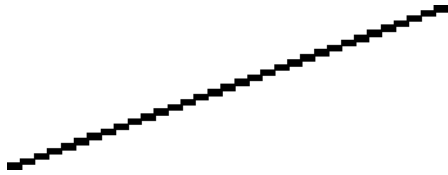

1. The problem may be inherent in the image. Try to improve the image with the application you are using to edit it.
2. Check that you are using appropriate print-quality settings, see the user's guide.
3. Select the custom print-quality options in the driver dialog, and turn on the **Maximum detail** option (if available).

### Lines print double or in the wrong colors

This problem can have various visible symptoms:

- Colored lines are printed double, in different colors.

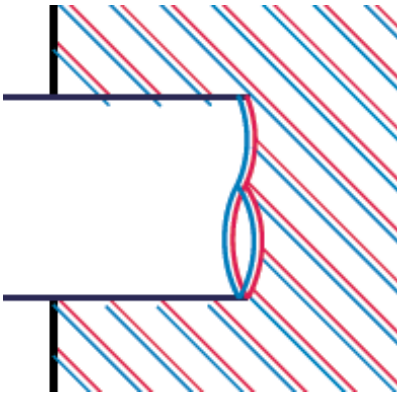



- The borders of colored blocks are wrongly colored.

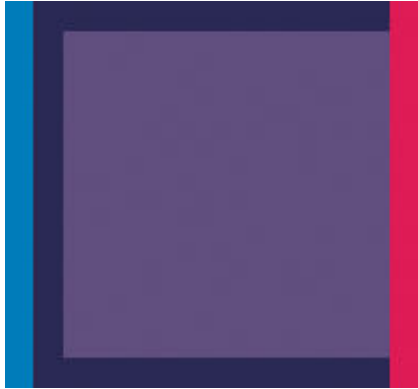

To correct this kind of problem, align the printhead. See [Align the printhead on page 129](#).

### Lines are discontinuous

If your lines are broken in the following way:



1. Check that you are using appropriate print-quality settings, see the user's guide.
2. Align the printhead. See [Align the printhead on page 129](#).

### Lines are blurred



Humidity can cause ink to soak into the paper, making the lines blurred and fuzzy. Try the following:

1. Check that your environmental conditions (temperature, humidity) are suitable for high-quality printing.
2. Check that the paper type selected in the front panel is the same as the paper type you are using.

3. Try changing to a heavier paper type, such as HP Heavyweight Coated Paper.
4. Select a paper type that is slightly thinner than the paper you have loaded; this will persuade the printer to use less ink. Here are some example paper types in ascending order of thickness: Plain Paper, Coated Paper, Heavyweight Coated Paper.
5. If you are using glossy paper, try changing to a different type of glossy paper.
6. Align the printhead. See [Align the printhead on page 129](#).

### Line lengths are inaccurate

If you have measured your printed lines and find that the lengths are not sufficiently accurate for your purposes, you can try to improve line length accuracy in the following ways.

1. Print on HP Matte Film, for which your printer's line length accuracy is specified.  
Polyester film is about ten times more dimensionally stable than paper. However, using film that is thinner or thicker than HP Matte Film will reduce line length accuracy.
2. Set the Print Quality slider to **Quality**.
3. Maintain the room at a steady temperature between 10 and 30°C (50 and 86°F).
4. Load the roll of film and let it rest for five minutes before printing.
5. If you are still not satisfied, try recalibrating the paper advance.

### The whole image is blurry or grainy



1. Check that the paper type you have loaded corresponds to the paper type selected in the front panel and in your software.
2. Check that you are printing on the correct side of the paper.
3. Check that you are using appropriate print-quality settings. In some cases, you can overcome a print-quality problem merely by selecting a higher print-quality level. For instance, if you have set the Print Quality slider to **Speed**, try setting it to **Quality**.
4. If the problem remains, align the printhead. See [Align the printhead on page 129](#).
5. If the problem remains, perform paper advance calibration.

If the problem persists despite all the above actions, contact your customer service representative for further support.

## The paper is not flat

If the paper does not lie flat when it comes out of the printer, but has shallow waves in it, you are likely to see defects in the printed image, such as vertical stripes. This can happen when you use thin paper that becomes saturated with ink.



1. Check that the paper type you have loaded corresponds to the paper type selected in the front panel and in your software.
2. Try changing to a thicker paper type, such as HP Heavyweight Coated Paper.
3. Select a paper type that is slightly thinner than the paper you have loaded; this will persuade the printer to use less ink. Here are some example paper types in ascending order of thickness: Plain Paper, Coated Paper, Heavyweight Coated Paper.

## The print is scuffed or scratched

The black ink pigment can be scuffed or scratched when touched by a finger, a pen or some other object. This is particularly noticeable on coated paper.

Glossy paper may be extremely sensitive to the basket or to anything else that it contacts soon after printing, depending on the amount of ink used and the environmental conditions at the time of printing.

To reduce the risk of scuffs and scratches:

- Handle prints carefully.
- Avoid stacking prints on top of each other.
- Catch your prints as they are cut from the roll and do not let them fall into the basket. Alternatively, leave a sheet of paper in the basket so that freshly printed sheets do not make direct contact with the basket.
- Increase the drying time. At the front panel, press , then **Printer Preferences > Print Retrieval > Select drying time > Extended**.

## Ink marks on the paper

This problem can occur for several different reasons.

### Horizontal smears on the front of coated paper

If a lot of ink is used on plain or coated paper, the paper absorbs the ink quickly and expands. As the printhead moves over the paper, the printhead may come into contact with the paper and smear the printed image. This problem is normally seen only on cut sheets of paper (not on roll paper).

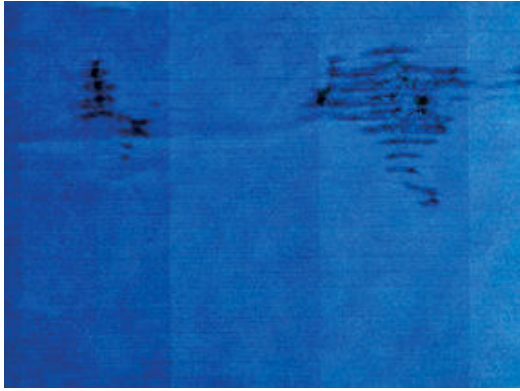

Whenever you notice this problem, cancel the printing job immediately. Press  and also cancel the job from your computer application. Soaked paper can damage the printhead.

Try the following suggestions to avoid this problem:

1. Check that the paper type you have loaded corresponds to the paper type selected in the front panel and in your software.
2. If using sheet paper, try rotating the sheet 90 degrees. The orientation of the paper fibers may affect performance.
3. Try changing to a thicker paper type, such as HP Heavyweight Coated Paper.
4. Select a paper type that is slightly thinner than the paper you have loaded; this will persuade the printer to use less ink. Here are some example paper types in ascending order of thickness: Plain Paper, Coated Paper, Heavyweight Coated Paper.
5. Try to increase the margins by relocating the image to the center of the page using your software application.

### **Ink marks on the back of the paper**

Clean the platen with a soft cloth. Clean each rib separately.

### **Black ink comes off when you touch the print**

This problem may be caused by printing with matte black ink on glossy paper. The printer will not use matte black ink if it knows that the paper will not retain it. To be sure of avoiding matte black ink, you can select Photo Glossy Paper as the paper type (in the Photo Paper category).

### **Edges of objects are stepped or not sharp**

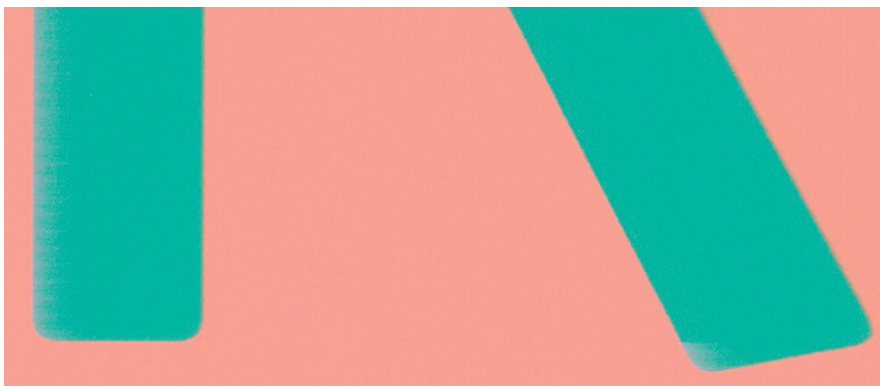

If edges of objects or lines appear to be poorly defined or lighter in density, and you have already set the print-quality slider to **Quality** in the driver dialog, select the custom print-quality options, and try setting the quality level to **Normal**.

### Edges of objects are darker than expected



If edges of objects seem darker than expected, and you have already set the print-quality slider to **Quality** in the driver dialog, select the custom print-quality options, and try setting the quality level to **Speed**.

### Vertical lines of different colors

If your print has vertical bands of different colors along it:

1. Try using thicker paper, choosing from the recommended paper types such as HP Heavyweight Coated Paper.
2. Try using higher print-quality settings. For instance, if you have set the Print Quality slider to **Speed**, try setting it to **Quality**.

### White spots on the print

You may notice white spots on the print. This is probably due to paper fibers, dust or loose coating material. To avoid this problem:

1. Try cleaning the paper manually with a brush before printing, to remove any loose fibers or particles.
2. Always keep the cover of your printer closed.
3. Protect your paper rolls and sheets by storing them in bags or boxes.

## Colors are inaccurate

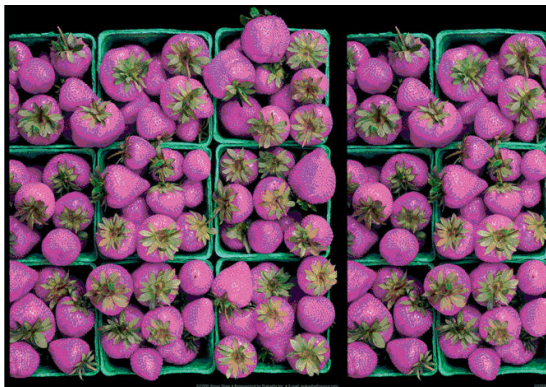

If the colors of your print do not match your expectations, try the following:



1. Check that the paper type you have loaded corresponds to the paper type selected.
2. Check that you are printing on the correct side of the paper.
3. Check that you are using appropriate print-quality settings. For the most accurate colors, select **Speed** or **Best** quality.
4. Print the print-quality diagnostic report. See [General print-quality troubleshooting on page 133](#).

## Colors are fading

If you print on instant-dry photo paper, your prints will fade rapidly. If you plan to display the prints for more than two weeks, you should laminate them to achieve longer life.

Prints on swellable coated papers will fade much less rapidly. However, lamination will increase the life of prints (depending on the type of lamination) with all paper types. For more information, consult your laminate provider.

## The image is incomplete (clipped at the bottom)

- Did you press  before all the data were received by the printer? If so, you have ended the data transmission and will have to print the page again.
- The **I/O timeout** setting may be too short. This setting determines how long the printer waits for the computer to send more data, before deciding that the job is finished. From the front panel, increase the **I/O timeout** setting to a longer period and then send the print again. Press , then **Connectivity** > **Advanced setup** > **Select I/O timeout**.
- There may be a communications problem between your computer and the printer. Check your USB or network cable, or your Wi-Fi connection.
- Check to make sure that your software settings are correct for your current page size (for example, long-axis prints).
- If you are using network software, make sure it has not timed out.

## The image is clipped

Clipping normally indicates a discrepancy between the actual printable area on the loaded paper and the printable area as understood by your software.

- Check the actual printable area for the paper size you have loaded.  
printable area = paper size – margins
- Check what your software understands to be the printable area (which it may call "printing area" or "imageable area"). For example, some software applications assume standard printable areas that are larger than those used in this printer.
- If you have defined a custom page size with very narrow margins, the printer may impose its own minimal margins, clipping your image slightly. You may want to consider using a larger paper size.
- If your image contains its own margins, you may be able to print it successfully by using the **Clip Contents by Margins** option.
- If you are trying to print a very long image on a roll, check that your software is capable of printing an image of that size.
- You may have asked to rotate the page from portrait to landscape on a paper size that is not wide enough.
- If necessary, reduce the size of the image or document in your software application, so it fits between the margins.

There is another possible explanation for a clipped image. Some applications, such as Adobe Photoshop, Adobe Illustrator and CorelDRAW, use an internal 16-bit coordinate system which means that they cannot handle an image of more than 32,768 pixels.



---

**NOTE:** An image 32,768 pixels long would print at a length of 1.39 m (54.61 in) if you select Best or Quality in the driver, 2.78 m (109.23 in) if you select Fast, Normal or Speed in the driver.

---

If you try to print an image larger than this from these applications, the bottom of the image may be clipped. To print the whole image, try these suggestions:

- The driver dialog includes an option called **Max. application resolution**, which enables you to print successfully in this situation. You will not normally need to change the default setting, which is **Auto**. However, you can find the option in the **Advanced** tab, under **Document Options > Printer Features**.
- Save the file in another format, such as TIFF or EPS, and open it with another application.
- Use a RIP to print the file.

## Some objects are missing from the printed image

Large quantities of data may be necessary to print a high-quality large-format print job, and in some specific workflows there may be issues that can lead to some objects missing from the output. Here are some suggestions to help you to avoid this problem.

- Tell the HP-GL/2 driver to send the image as a bitmap.
- Select a smaller page size and scale to the desired final page size in the driver or in the front panel.
- Save the file in another format, such as TIFF or EPS, and open it with another application.
- Use a RIP to print the file.
- Reduce the resolution of bitmap images in your application software.
- Select a lower print quality in order to reduce the resolution of the printed image.



---

**NOTE:** If you are working under Mac OS, not all of these options are available.

---

These options are suggested for troubleshooting purposes and may adversely affect the final output quality or the time necessary to generate the print job. Therefore, they should be cancelled if they do not help to solve the problem.

### **A PDF file is clipped or objects are missing**

In older versions of Adobe Acrobat or Adobe Reader, large PDF files could be clipped or lose some objects when printing with the HP-GL/2 and HP RTL driver at high resolution. In order to avoid such problems, upgrade your Adobe Acrobat or Adobe Reader software to the latest version. From version 7 onwards, these problems should be solved.



# Print mode summary table

Media Family in Front Panel	Bond and Coated Paper	Technical Paper	Adhesive Paper	Photo Paper	Film
	<p><b>Plain Paper</b></p> <p>HP Natural Tracing Paper</p> <p>Generic Natural Tracing Paper &lt; 65 g/m2</p> <p>Generic Natural Tracing Paper &gt; 65 g/m2</p> <p><b>HP Universal Bond Paper</b></p> <p>HP Recycled Bond Paper</p> <p>HP Bright White Inkjet Bond Paper</p> <p><b>Blueprint</b></p>	<p>HP Natural Tracing Paper</p> <p>Generic Natural Tracing Paper &lt; 65 g/m2</p> <p>Generic Natural Tracing Paper &gt; 65 g/m2</p> <p>Vellum</p> <p>Natural Tracing Paper</p> <p>Rubber Resistant</p>	<p><b>HP Coated Paper</b></p> <p>Coated Paper</p> <p>Adhesive Paper</p>	<p>HP Universal Gloss Photo Paper</p> <p>HP Universal Satin Photo Paper</p> <p>HP Premium Gloss Photo Paper</p> <p>HP Premium Satin Photo Paper</p> <p>Polypropylene Satin Paper</p> <p>Phot Semi-gloss/Satin Paper</p> <p>Photo glossy paper</p>	<p><b>Transparent/Clear Film</b></p> <p><b>Matte Film</b></p>
fast (-2)	1p bidi 30ips	1p L2R 30ips, 40ips retrace	1p L2R 30ips, 40ips retrace		1p bidi 30ips
econo fast (-1)	1p bidi 40ips	1p L2R 30ips, 40ips retrace	1p L2R 30ips, 40ips retrace		1p bidi 30ips
normal (0)	K/C: 1p/2p/NUA 30ips	4p L2R 30ips, 40ips retrace	4p L2R 30ips, 40ips retrace	8p L2R 20ips	K/C: 1p/2p/NUA 30ips
best (+1)	6p L2R 30ips, 40ips retrace	6p L2R 30ips, 40ips retrace	6p L2R 30ips, 40ips retrace	10p L2R 20ips, 40ips retrace	4p L2R 30ips, 40ips retrace
max dpi (+2)				12p L2R 18ips, 40ips retrace	
	Not Supported				

**Key**  
# of passes & print direction  
carriage speed

## Printer Emulation

HP DesignJet 500/800/100 Printer Series emulation works only in Normal & Best print modes. If Fast mode is selected emulation will be void.



---

**NOTE:** Emulation only works using Plain & Coated media.

---

# Scan and copy quality troubleshooting

In this chapter the most common defects and failure modes are shown, sorted by relevance and frequency of appearance. A defect is a common image artifact that usually appears when using any CIS scanner. These are due to incorrect settings, product limitations, or easily solvable mistakes. A failure mode is due to malfunctions of some of the scanner components.

Scanner cleanliness is paramount to ensure good image quality. Before proceeding with any troubleshooting, please make sure the glass scanbars are clean and in good condition and the pressure sliders (wide, white plastic parts) are also in good and clean condition.

Some of the corrective actions proposed here require the use of the Scanner Diagnostic Plot, which you can print and scan as indicated in [The scanner diagnostic plot on page 168](#). When copying, to be sure that the defect does not come from the printing function, use this diagnostic plot to detect any scanning issue. Please do not use any printed version of this guide to test the scanner, as the resolution of the images included here is insufficient. Use the diagnostic plot when recommended in response to any of the errors described in this chapter.

First, check that the latest firmware is installed. See [Update the firmware on page 176](#).

## Random vertical lines

This is one of the most common issues in sheet-fed scanners. Usually, the vertical streaks are caused by dust particles inside the scanner, or miscalibration of the scanner (in these cases, the problem can be solved). Here are some examples of images suffering from vertical lines or streaks. Please note the black arrow indicating the scanning direction in these examples.



### Actions

1. Clean the scanner's glass plate and the original to be scanned, as described in [Preventive maintenance on page 529](#). Reboot the printer and re-scan your original afterwards.
2. If the streaks remain, recalibrate the scanner as indicated in [Support Menus, Diagnostic Plots & Calibrations on page 181](#). Reboot the printer and re-scan your original after the calibration is completed.
3. If the streaks still remain; replace the Scanbars and sliders and recalibrate the scanner.

 **NOTE:** The problem of vertical streaks cannot always be solved, due to the technological limitations of CIS technology. HP offers HD Scanners with CCD technology for higher quality requirements. If the streaks remain after the corrective actions explained above, then no further action can be taken to improve the image quality, except to buy a more expensive CCD scanner.

## Wrinkles or folds

Scanners based on CIS technology have a high optical resolution within their focus plane, at the price of a very limited depth of field. Hence, the images are sharp and detailed when the scanned original is perfectly flat

against the glass plate. However, whenever the original contains wrinkles or folds, these defects are clearly visible in the scanned image (as shown in the following example).

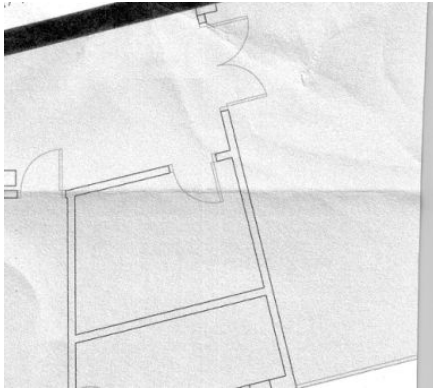

### Actions

1. Re-scan the original and set the background color and noise removal to **Off**. If copying, set the content type to **IMAGE**.
2. If the problem persists, re-scan the original at a lower scanner resolution (300 dpi or lower resolution if scanning, Fast or Normal if copying). It may also help to flatten the original manually as much as possible before scanning it again.



**NOTE:** The problem of wrinkles cannot always be solved, due to the technological limitations of CIS technology. HP offers HD Scanners with CCD technology for higher quality requirements. If the wrinkles remain after the corrective actions explained above, then no further action can be taken to improve the image quality, except to buy a more expensive CCD scanner.

### Line discontinuities

When scanning or copying large originals, you may sometimes find issues such as that shown in the following image, where a straight line (it does not necessarily have to be horizontal) appears with discontinuities or small steps. Please note the black arrow indicating the scanning direction in this example.



### Actions

1. Repeat the scan, and this time make sure that the product is correctly positioned (it is flat on the floor and it does not move). Turning the original 90 or 180 degrees and scanning it again may also solve the problem.
2. If the problem persists, check that the original to be scanned is not skewed, and that it does not become skewed during the scan. If so, please refer to [Incorrect paper advance, skew during scanning, or horizontal wrinkles on page 163](#). You might also want to deactivate the automatic de-skew algorithm as indicated in [A copied or scanned image is very skewed on page 167](#).

3. If there is no skew but the problem persists, clean and calibrate the scanner see [Preventive maintenance on page 529](#) to see how to clean the scanner, and see [Support Menus, Diagnostic Plots & Calibrations on page 181](#) to see how to Calibrate the scanner. See "Scanner Maintenance" in the user guide for more information. Take care not to move the printer during the calibration, and check that the maintenance sheet is correctly positioned before starting the calibration. Also check that the maintenance sheet is not damaged before calibrating the scanner (an old or damaged maintenance sheet may cause this problem); if it is damaged, reprint it.
4. If the problem persists, proceed to analyze the following areas of the diagnostic plot:
  - D, H and L (for three modules, 0-Left, 1-Middle, and 2-Right and its intersection).

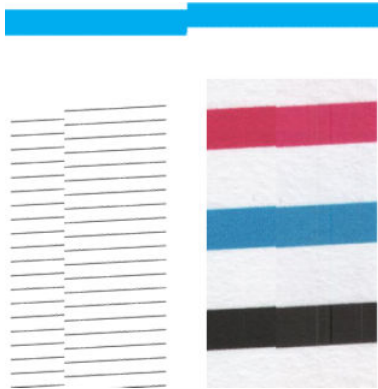

The two vertical thin black lines at the beginning and the end of the diagnostic plot show, approximately, the position of the intersection between Scanbars, where this kind of error usually appears. If the error appears outside these areas and the line discontinuity varies along the plot try to recalibrate the OPT wheel. See [Support Menus, Diagnostic Plots & Calibrations on page 181](#).

If unsuccessful try to reset the Scanbars. If the problem persists replace the [OPT Wheel F9A30-60038 on page 453](#) and recalibrate it again. If the problem still persists replace the Scanbars.

## Light colored area fills are missing in the scan or copy

When scanning or copying a map with a light are fill in the top of the plot, the **Background color removal** setting could interpret it as a color in the background and may remove it, together with the lighter area fills. This could cause some light area fills to disappear. The example below shows the original image on the left and the scanned image on the right.

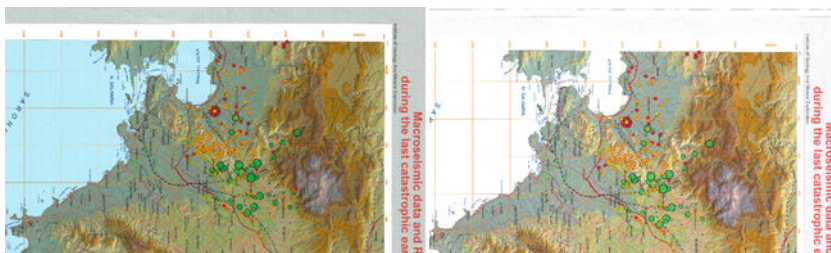

## Actions

1. Repeat the scan or copy with **Background color removal** set to **Off**, or, in the case of copying, you can select **Image** as the content type. See Scan settings and Copy settings sections of the User Guide.
2. If the problem persists, see [Preventive maintenance on page 529](#) to see how to clean the scanner, and see [Support Menus, Diagnostic Plots & Calibrations on page 181](#) to see how to Calibrate the scanner. Repeat it again with **Background color removal** set to **Off**.

## Grain in area fills when scanning plain paper

When making copies of an original containing area fills, if the paper used in the printer is plain paper (for instance, HP Universal Bond or HP Bright White Inkjet Bond), some grain may appear in the image. This error may also appear in scanned files of originals that were printed on textured paper. The example below shows the original image on the left and the scanned, grainy image on the right.



## Actions

1. Please look at the original and check if it is dirty, has fingerprints on it or if the grain is already present in the print. If not, then proceed to step 2.
2. If it is a copy, repeat it, setting the content type to **Image**.
3. If the problem persists:
  - If the problem appears when copying, use Best quality. We also recommend using coated or glossy paper in order to avoid grain in copies.
  - If the problem appears in a scanned file, scan at a lower resolution (300dpi or less), and a lower compression file format
4. If the problem persists, see [Preventive maintenance on page 529](#) to see how to clean the scanner, and see [Support Menus, Diagnostic Plots & Calibrations on page 181](#) to see how to Calibrate the scanner. Check that the maintenance sheet is also clean, and that it is not damaged before calibrating the scanner (an old or damaged maintenance sheet may cause this problem); if it is damaged, reprint it.

5. If the problem persists, proceed to analyze areas I and J of the diagnostic plot across modules =, 1 and 3. In the three examples below, the top example is ideal, the middle example can be regarded as acceptable; but, if you see something similar to the bottom example (or worse), replace the scanbar.

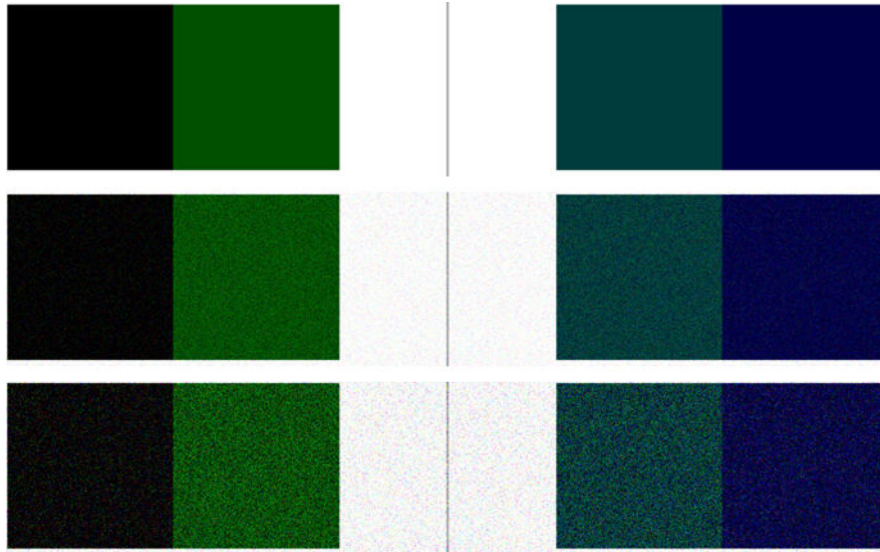

### Small color differences between adjacent Scanbars

When scanning wide plots, sometimes slightly different colors can be seen at both sides of the junction between two scanbars. This issue, if present, can be easily seen by analyzing patterns A and G of the diagnostic plot at the intersection between scanbars. Here are some examples. Please note the black arrow indicating the scanning direction in these examples.

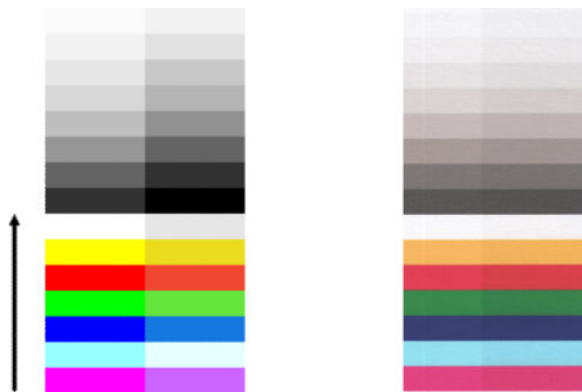

Sometimes the color mismatch between adjacent modules can be enormous, showing a serious scanner malfunction, as in the following example. If this occurs, see [Completely wrong colors on page 164](#).



## Actions

1. Reboot the scanner and repeat the scan or copy. If the problem persists, repeat the scan or copy, setting the background color removal to Off or turning the original 90 degrees before scanning it again.
2. If the problem persists, see [Preventive maintenance on page 529](#) to see how to clean the scanner, and see [Support Menus, Diagnostic Plots & Calibrations on page 181](#) to see how to Calibrate the scanner. If calibration ended without errors, try to scan or copy again.
3. If the problem persists, proceed to analyze patterns A and G in the diagnostic plot, if you see some color differences between left and right sides of the bars for neutral and vivid colors, call HP support and report “small color differences between adjacent”. Otherwise, if you see color differences for vivid colors but not for neutral colors, see [Clipping in dark or light areas on page 159](#). If necessary, see also [Grain in area fills when scanning plain paper on page 154](#).

## Vertical light lines at the intersection between Scanbars

This problem can be found when scanning large uniform area fills which are made of some light color. You sometimes find light vertical bands (around 0.5 cm wide) at the intersection between two scanbars, as in this example. Please note the black arrow indicating the scanning direction in this example.



## Actions

1. Repeat the scan or copy, rebooting the printer and setting the background color removal to Off or turning the original 90 degrees before scanning it again.
2. If the problem persists, see [Preventive maintenance on page 529](#) to see how to clean the scanner, and see [Support Menus, Diagnostic Plots & Calibrations on page 181](#) to see how to Calibrate the scanner. Then proceed to analyze pattern B of the diagnostic plot at the intersections between Scanbars. The example below shows a good result on the left and a bad result on the right: the latter has light vertical banding 0.5 cm wide at the intersection between two Scanbars.



3. If the problem persists, see [Preventive maintenance on page 529](#) to see how to clean the scanner, and see [Support Menus, Diagnostic Plots & Calibrations on page 181](#) to see how to Calibrate the scanner. Then proceed to analyze pattern B of the diagnostic plot at the intersections between Scanbars. The example below shows a good result on the left and a bad result on the right: the latter has light vertical banding 0.5 cm wide at the intersection between two Scanbars.



4. If you see the kind of result shown on the right, try to reseat the Scanbars and recalibrate the scanner (see [Support Menus, Diagnostic Plots & Calibrations on page 181](#)). If it persists; try to replace the Scanbars and sliders (all 3 scanbars need to be replaced).

## Variable line thickness or missing lines

When scanning some CAD plots at low resolution, mostly when working with grayscale or black-and-white prints that contain very thin lines, you may see a variation in line thickness, or even some missing lines, in some places:

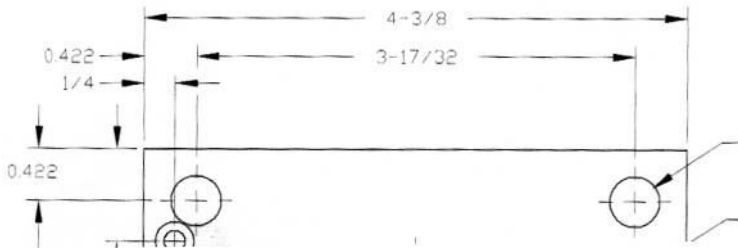

### Actions

1. Repeat the scan or copy using a higher resolution (600 dpi). You should also set **Background color removal to Off**, or, for copying, set the content type to **Mixed**. You might also deactivate the automatic de-skew as explained in [A copied or scanned image is very skewed on page 167](#). In case you were working in black-and-white mode, we recommend using grayscale instead.
2. If the problem persists, turn the original plot 90 degrees before scanning it again.
3. If the problem persists, see [Preventive maintenance on page 529](#) to see how to clean the scanner, and see [Support Menus, Diagnostic Plots & Calibrations on page 181](#) to see how to Calibrate the scanner.
4. If the problem persists, see [Defocus, blurring and fading colors on page 161](#).

## Inaccurately reproduced colors

You have to deal with several variables when attempting to match colors with the original you are scanning and the copy or scanned file you obtain as a result. If you find undesired colors in cases like the example shown below (original on the left, scanned image on the right), you can follow these guidelines.

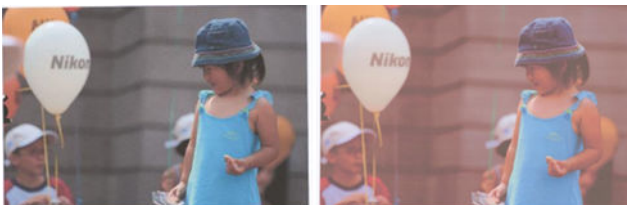

## Actions

1. When dealing with copies, you must take into account that good color matching between a given original and its copy can be achieved only if both are printed on the same type of paper. In the case of scanned files, good color matching can be achieved only if your monitor is color-calibrated or compliant with sRGB or AdobeRGB standards.
2. Reboot the printer and scan or copy again.
3. If the above conditions are met, you should also take into account that various scanner settings can affect the final color result, such as Lighter/Darker, background color or noise removal, content type and paper type. To obtain the best possible colors, set the Darker/Lighter to Normal, the **Background color and noise removal** to **Off**, set the Content Type to **Image** (only if copying), and do not select the Translucent Media.
4. For optimum color results, see [Preventive maintenance on page 529](#) to see how to clean the scanner, and see [Support Menus, Diagnostic Plots & Calibrations on page 181](#) to see how to Calibrate the scanner.
5. Avoid placing the scanner in direct sunlight or near sources of heat or cold.

## Color fringing

The problem called “color fringing” occurs when the scanner is affected by incorrect paper advance and/or miscalibration. Nevertheless, some amount of color fringing is unavoidable, especially at high scanning speeds. It can be seen at the borders of sharp black text over a white background, as in the example below (original on the left, scanned image on the right). Please note the black arrow indicating the scanning direction.



## Actions

1. Repeat the scan after increasing the scanner’s resolution (choose 300dpi or higher quality if scanning, Best if copying). Turn your original 90 degrees, if possible, before scanning it again.
2. If the problem persists, see [Preventive maintenance on page 529](#) to see how to clean the scanner, and see [Support Menus, Diagnostic Plots & Calibrations on page 181](#) to see how to Calibrate the scanner. Repeat the scan at a high resolution (300dpi or higher if scanning, Best if copying) and check whether the problem disappears.
3. If the problem still persists, you can diagnose this issue by analyzing the E patterns of the diagnostic plot. The black horizontal lines appear slightly colored at the top and bottom of each end (in the example on the right, below). Normally, they look red at the top and blue or green at the bottom, but it could be the other way around.



If you see this effect, call HP support and report “color fringing problem after calibration”.

## Clipping in dark or light areas

Sometimes you may see that the scanned file or copy of one of your plots has lost detail in light or dark areas (or both), as in the example below: original on the left, scanned image on the right.



Image © www.convincingblack.com, reproduced with permission.

### Actions

1. If you are making copies, and the original is printed on photographic paper, while you are copying it onto matte paper, this problem is to be expected. However, you can try to reboot the printer and set the background color and noise removal to Off and also change the Lighter/Darker settings; this also applies if you see this problem in scanned files.
2. If the problem persists, repeat the scan or copy using a higher resolution (300dpi or higher if scanning, Normal or Best if copying). Set the content type to **Image** (if copying).
3. If the problem persists, recalibrate the scanner, see [Preventive maintenance on page 529](#). Make sure you clean the maintenance sheet before calibrating the scanner, and check that the maintenance sheet is not damaged. Re-scan your original after the calibration is completed.
4. If the problem persists, analyze patterns M (0, 1 and 2 modules) of the diagnostic plot. If you can distinguish lightness steps beyond the upper and lower specified thresholds, then the scanner is fine. Here you can see some examples of correct and incorrect functioning.

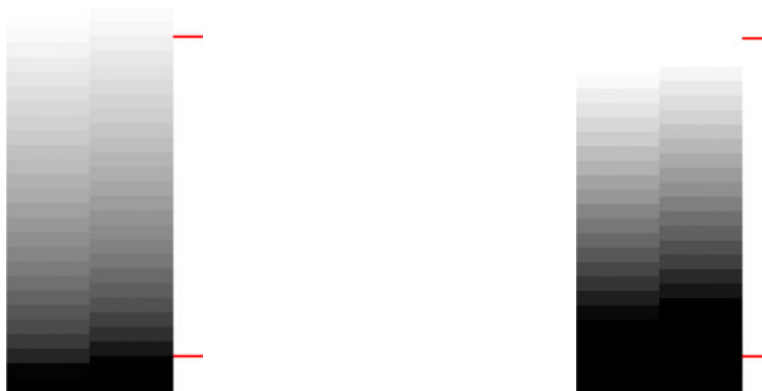

If your scanned pattern looks like the incorrect one on the right, whether the clipping is in dark and/or light areas, first try to reset the Scanbars and recalibrate. If it persists; replace the Scanbars and sliders, then recalibrate.

## Flare in the image when scanning glossy originals

If the scanner is miscalibrated, or if the original plot you are trying to scan is very glossy or reflective, you can sometimes find flare in the scanned image, as in the following example: original on the left, scanned image on the right.

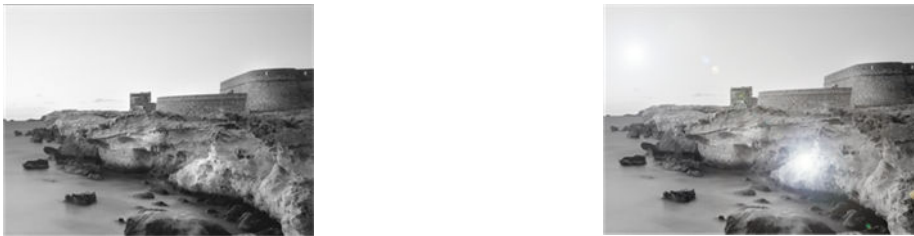

Image © www.convincingblack.com, reproduced with permission.

### Actions

1. Clean the original and the scanner's glass plate, then scan again. See [Preventive maintenance on page 529](#).
2. If the problem persists, recalibrate the scanner, see [Support Menus, Diagnostic Plots & Calibrations on page 181](#) to see how to Calibrate the scanner. Re-scan your original after the calibration is completed.
3. If the problem persists, see [Clipping in dark or light areas on page 159](#).

## Vertical red and green bands over white or black background

If the scanner has not been calibrated for a long period of time, or if the last calibration failed, you can sometimes see defects like the following. Please note the black arrow indicating the scanning direction in this example: original on the left, scanned image on the right.



### Actions

1. First, reboot the printer and re-scan or copy. Clean and calibrate the scanner, see [Preventive maintenance on page 529](#) to see how to Clean the scanner, and see [Support Menus, Diagnostic Plots & Calibrations on page 181](#) to see how to Calibrate the scanner. Scan your original again and check that the colored vertical bands have disappeared.
2. If the problem persists, try to reset the Scanbars and recalibrate the scanner. If it still persists, try to replace the Scanbars and sliders and recalibrate the scanner.

## Vibration

If your printer is not properly placed on a flat surface, or if the scanner lid does not close correctly, you may sometimes find that the scanned image suffers from vibration, as in the following example: original on the left, scanned image on the right.



1. Make sure that the scanner is placed on a flat surface, the scanner lid is correctly closed, and the printer is not working while you are scanning. Scan your original again.
2. If the problem persists, change (increase or decrease) the scanning resolution and re-scan your original. We also recommend turning the original 90 degrees before scanning it again.
3. If the problem persists, analyze pattern D of the diagnostic plot. If you see the problem shown on the right; check that the scanner lid is properly closed, open and close it, by pushing it down until a you hear a click. Recalibrate the scanner and try again.

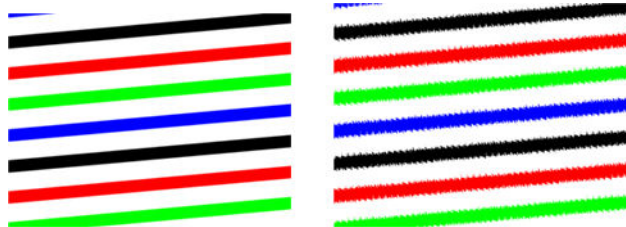

## Defocus, blurring and fading colors

CIS technology scanners are tuned to work at a fixed focal distance, and they are very sensitive to small variations in the position of the original with respect to the scanner glass plate. If the scanner lid is not properly closed, or if the original has deep wrinkles or texture, you may sometimes find problems as in the following example (on the right), where the scanned image is blurred and colors are faded.

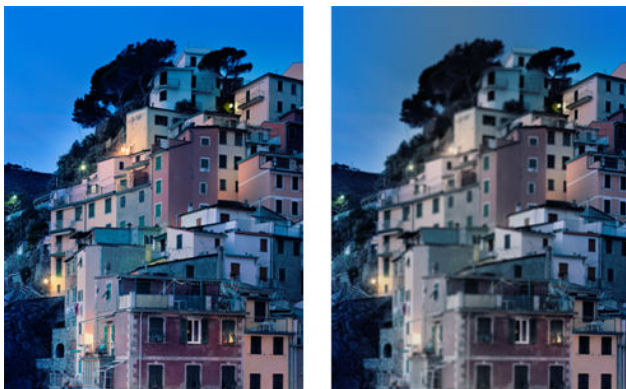

## Actions

1. Check that the scanner lid is properly closed, open and close it by pushing it down until you hear a click. Then calibrate the scanner as indicated in [Support Menus, Diagnostic Plots & Calibrations on page 181](#), then reboot and repeat the scan.
2. If the problem persists, repeat the scan or copy using a higher resolution (300dpi or more if scanning, Normal or Best if copying). You should also set background color removal to Off, or set the content type to **Mixed** if copying.
3. If the problem persists, analyze pattern F in modules 0, 1 and 2 of the diagnostic plot. A correct example is given below, followed by two incorrect examples. Note that there is a black ring near the center of pattern F. In this step, you must look at the region near the black ring. If you can see discontinuities in the black and white lines, try to reset the Scanbars and recalibrate the scanner. If the problem persists; try to replace the Scanbars and the sliders, then recalibrate the scanner.

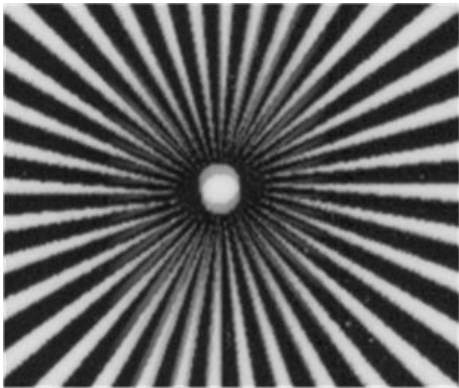
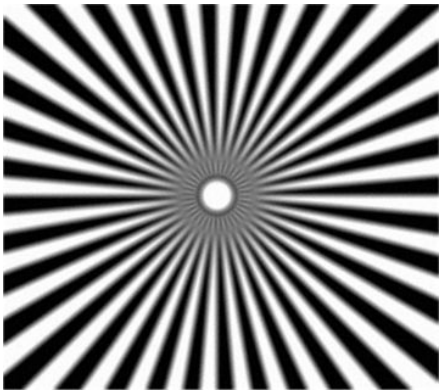
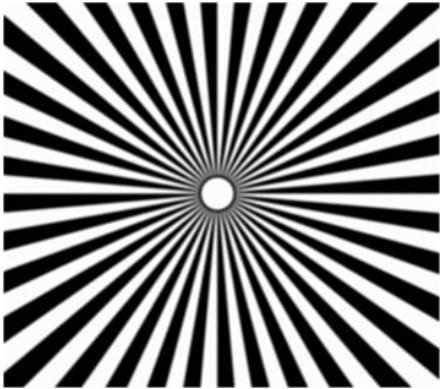

## Incorrect paper advance, skew during scanning, or horizontal wrinkles

You may encounter problems with some thick glossy originals being moved through the scanner's paper path. In some cases, the original may become skewed during the scanning process.

If some of the paper rollers are not working correctly, you may find small horizontal wrinkles in the scanned image, due to the paper being stuck in some regions while not in others.

### Actions

1. Turn your original 90 degrees and repeat your scan.
2. Check media is within specification.
3. If the problem persists, open the scanner lid. Clean the feed wheels (small black rubber) and the pressure sliders (wide white plastic). If you find dust particles or objects that obstruct the movement of the pressure sliders, try to remove them, then close the scanner lid and repeat your scan.
4. If the problem persists, restart the scanner by turning it off and on again. If you find an error message on the front panel during this operation, review the error messages section.
5. If the problem persists, analyze patterns D, K, and L of the diagnostic plot. The plot should look like this:



If you see an image resembling the incorrect examples below, call HP support and report an "incorrect paper advance" problem.



## Vertical black band 30 cm wide

Your scanner contains various scanner scanbars, each of which covers an area 30 cm (12 in) wide. If one of the modules fails, and the scanner hardware check does not detect the failure, you may see a black vertical band, corresponding to the area covered by a single scanbar, in your scanned image or copy. Here is an example (on the right). Please note the black arrow indicating the scanning direction in this example.



Original Scan affected by a CIS failing module

## Actions

1. Restart the scanner by turning it off and on again. If you find an error message on the front panel during this operation, call HP support and report the error message. If no error message appears, try repeating your scan.
2. If the problem persists, try to calibrate the scanner, see [Support Menu, Diagnostic Plots & Calibrations on page 181](#) to see how to Calibrate the scanner. If this operation fails, review the error messages section. If no error code appears, try to repeat your scan.
3. If the problem persists, try to reset the Scanbars and recalibrate the scanner. If it still persists; replace the Scanbars and recalibrate the scanner.

## The scanner damages some originals

HP is aware that this scanner may cause vertical scratches on inkjet originals on thick glossy paper. Very thin tracing paper or old originals may also be damaged. This is because CIS technology requires the original to be held down with high pressure to obtain accurate results and avoid blurring and defocus problems.

If the original you intend to scan is valuable, and if it belongs to one of the types described above (inkjet-printed, thick, glossy original or old/thin/tracing paper original), HP recommends using a CCD.

## Completely wrong colors

If some of the LEDs used for illumination in the scanner scanbars are failing, or the last calibration did not work correctly, although no error message was given on the front panel, you may experience some completely wrong colors in your scanned images, as in the example below: original on the left, scanned image on the right.

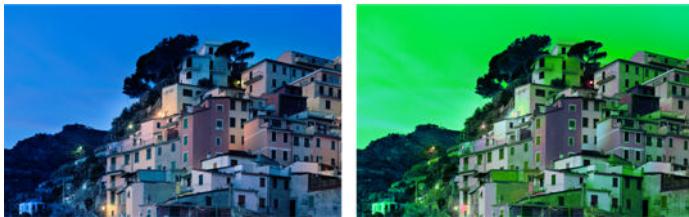

1. Restart the scanner by turning it off and on again. If you find an error message on the front panel during this operation, review the error messages section.
2. If no error message appears on the front panel during the restart process, try to calibrate your scanner, see [Support Menu, Diagnostic Plots & Calibrations on page 181](#).
3. If calibration succeeded, reboot and repeat your scan and check the colors.
4. If the colors are still wrong, analyze the whole diagnostic sheet. Check that you find completely wrong colors in the area corresponding to just one of the scanbars, as in the following figure. If so, try to reset the Scanbar and recalibrate the scanner. If it remains; replace the Scanbars and recalibrate the scanner.

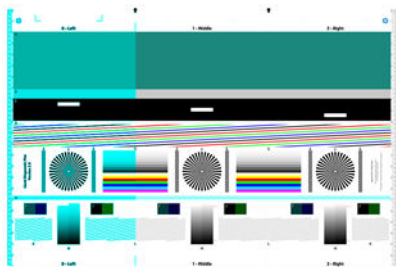



## Vertical distortion

If the lid sensor of the scanner fails, the scanner cannot detect when the lid is open. Hence, you can start a scan, and at some point find that the pressure sliders do not move the original through the scanner paper path. You may see images like the following when this happens (original on the left, scanned image on the right). Please note the black arrow indicating the scanning direction in these examples.

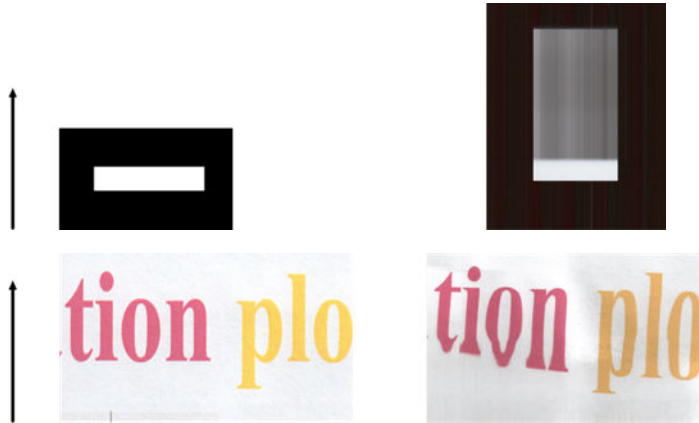

### Actions

- ▲ Open the scanner lid and close it by pushing it down until you hear a click. Then repeat your scan and visually check that the original advances correctly through the scanner path. If not, first try to calibrate the OPT wheel (see [Support Menus, Diagnostic Plots & Calibrations on page 181](#) to see how to Calibrate the OPT wheel) and try again. If it still fails; try to replace the [OPT Wheel F9A30-60038 on page 453](#) and recalibrate it.

## Object replication (ghosting)

This error very rarely appears in CIS scanners. However, you can occasionally find image defects like the following: original on the left, scanned image on the right.



Image © [www.convincingblack.com](http://www.convincingblack.com), reproduced with permission.

## Actions

1. Restart your printer. Then calibrate the scanner; see [Support Menus, Diagnostic Plots & Calibrations on page 181](#) to see how to Calibrate the scanner. Turn the original 90 degrees if possible before rescanning. You can also try to modify the lighter/darker setting.
2. If the problem persists, analyze pattern C, modules 0, 1, and 2, of the diagnostic plot. First try to reset the Scanbar and calibrate the scanner again. If it remains; replace the Scanbars and recalibrate it.



## Clipping or incorrect scale factor when down-scaling in copies and prints

When doing copies or prints (from USB, Embedded Web Server, or printer driver), the scaling setting is available with various possible options. If you are experiencing problems related to border clipping, or it seems that your print has lost the scale-factor adjustment, please read this section carefully in order to select the best value for the scaling setting in future jobs.

- **Custom (Precise scaling):** In this case, the content of the original image is scaled by the percentage factor that you have selected. For example, in an original CAD image with a 1:100 scale, if user selects scale to 50%, the printed plot will have an accurate scale of 1:200. Nevertheless, in the case of down-scalings when selecting a fixed percentage, some clipping of the marginal content of the plot may occur, as it is impossible for the printer to print up to the borders of the paper.
- **Fit To (Scale to fit into page size):** In this case, the content of the original image is scaled by the percentage necessary to make sure that all the content is correctly printed and no clipping occurs. Nevertheless, in the case of down-scalings when selecting fit to page, the scale-factor adjustment may not be an integer divisor of the original. For example, in an original CAD plot with a 1:100 scale on A2 paper size, if user selects scale to fit on A3 paper size, the scaling factor will not be exactly 50% and the scale of the printed plot will not be 1:200 exactly. However, the plot will be printed completely without clipping any content.

## Incorrect edge detection, mostly when scanning tracing paper

Tracing or translucent papers can be scanned with good results, although totally transparent papers are not supported. Nevertheless, the resulting image may have extra margins or some clipping of the content in some situations when detection of the edge of the paper is not accurate, which may also happen when scanning plain paper if the glass plate is dirty. In order to avoid these undesired effects, please follow these recommendations.

## Actions

1. Carefully clean the scanner's glass plate and the original to be scanned with a cloth. Turn the original 90 degrees if possible and re-scan it afterwards. Remember to select **Translucent** as the paper type at the scanner if your original is translucent.
2. If the problem persists, please calibrate your scanner, and re-scan your original again afterwards.
3. If the problem persists in the case of translucent paper, attach a sheet of white paper to the back of the original to be scanned.

## A copied or scanned image is very skewed

Originals are often loaded into the scanner with some degree of skew. In order to correct for this unavoidable problem, the scanner has a built-in automatic de-skew algorithm, which measures the skew in the original and rotates the scanned image so that the result is perfectly straight. However, in some cases the de-skew algorithm may increase the skew rather than correcting it. In other cases, the skew is so bad that it cannot be automatically corrected.



To load the original with minimum skew, grasp the original with the image facing up and your hands at left and right edges. You are recommended to avoid resting your hands or the original on the scanner's input tray. Push the original into the scanner insertion slot until you feel the whole top border of the original pressing against the scanner rubber rolls, which will load the original after a delay of 0.5 seconds. Now you can take your hands off the original. If you are not happy with the way the scanner has grabbed your original, you can touch  and try again.

The action of the automatic de-skew algorithm can be deactivated by pressing , then **Scan preferences** or **Copy preferences** (you might want to deactivate it in one case but not in the other). You can also deactivate the automatic de-skew from the **Settings** button at every new scanner job.

# The scanner diagnostic plot

## Prepare the printer and the paper to print the diagnostic sheet

Turn on your printer and wait until it is functioning. Then select the paper on which the diagnostic plot is going to be printed (you can reuse the diagnostic plot any time in the future, if it is saved carefully). Ideally, the diagnostic plot should be printed on glossy paper, and you are highly recommended to do that if you use your printer mostly for scanning or copying photo originals (posters, pictures printed on glossy paper, etc). If you use your printer mostly to scan or copy matte originals, then you can use any matte white paper to print the diagnostic plot. Please do not use recycled or tracing paper to print this plot. The size of the diagnostic plot is 610 × 914 mm (24 × 36 in). It can be printed on any 914 mm (36 in) landscape or 610 mm (24 in) portrait paper roll. You can also use a single sheet that is at least 610 × 914 mm (24 × 36 in).

You can print the diagnostic plot from the front panel: press , then , then **Printer Maintenance** > **Scanner Diagnostic**.

## Visual check for errors while printing the diagnostic sheet

Once the diagnostic plot is printed, the first step is to check that all the patterns included in it are correctly printed. The diagnostic plot, if printed correctly, should look like this:

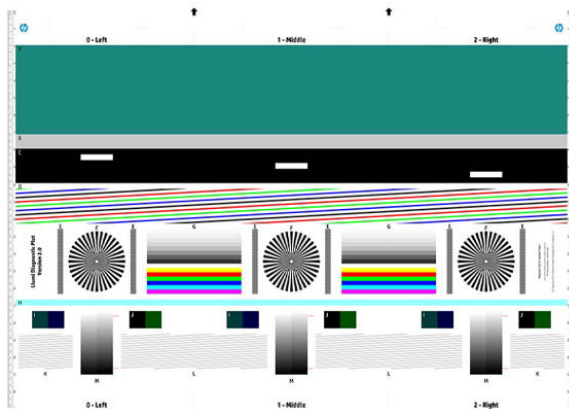

Some of the most common defects that may appear in a printed diagnostic plot are described below. If you find any of these problems, you should follow the recommended recovery procedure (see [Print-quality troubleshooting on page 133](#)). Once the printer has been diagnosed and it is working correctly, you can reprint the diagnostic sheet as described in [Prepare the printer and the paper to print the diagnostic sheet on page 168](#).

## Resolution

By looking at pattern F you may find problems with the printer's resolution for the loaded paper. Usually, this test does not reveal a printer problem, but a defect in the paper, which may not be suitable for printing the diagnostic sheet with the required quality.

Here is what you should see if all is well, followed by two defective examples.

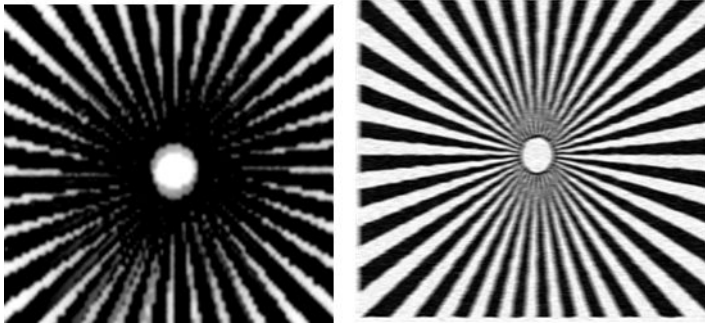
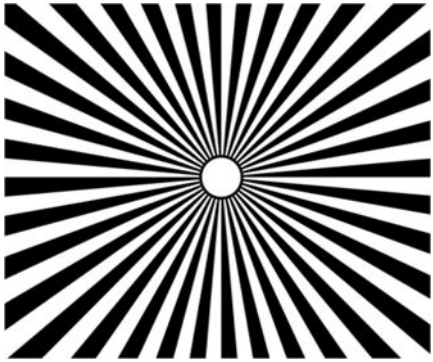

## Alignment

Looking at patterns D, K, and L, you may find problems with the printer's printhead alignment, which can cause defects such as the following.

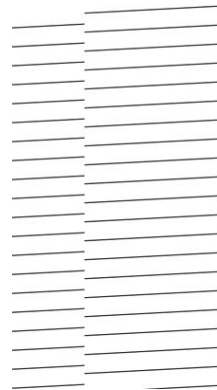
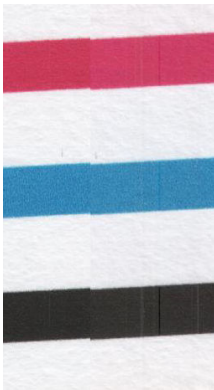

Additionally, misalignment problems can be seen in patterns D and G in the form of color fringing (which is exaggerated below, on the right). That is, the limits between two strong colors are not well defined or a third color appears between them.

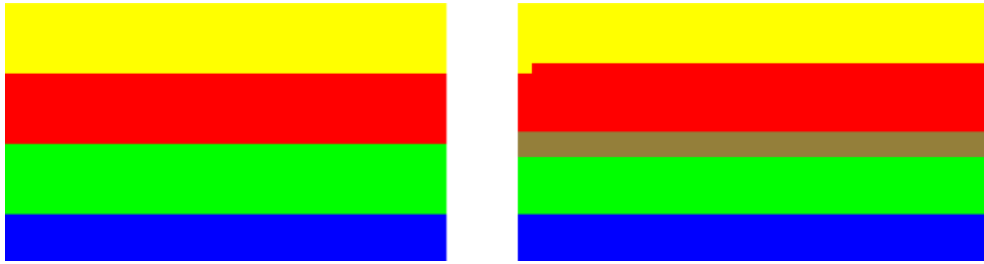



Finally, a special pattern for checking the printer's printhead alignment can be found at the top left of the diagnostic sheet. This pattern has no number as it is not used for scanner checking. It is made of three colored crosses that may be used to identify the problem in question. The correct pattern is shown on the left, an example of misalignment on the right.

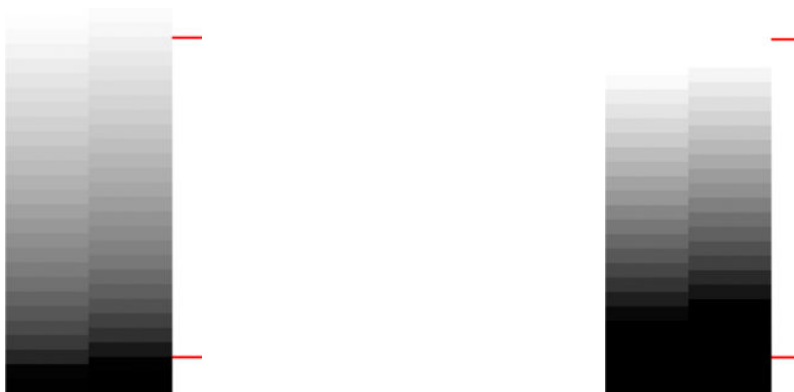

### Loss of shadow or highlight details

Looking at pattern H, you may find a problem with the color calibration of the printer (CLC process). If you can distinguish lightness steps beyond the upper and lower specified thresholds, then the printer is fine. Here you can see examples of correct functioning on the left, incorrect on the right.



If the printer does not pass this test, you should run a color calibration if the paper loaded in the printer can be calibrated (coated or glossy paper, for instance). The color calibration can be launched from the front panel by touching , then **Image Quality Maintenance** > **Color calibration**.

### Printer banding

Looking at patterns A, B, and C, you can see vertical banding problems. See [Horizontal lines across the image \(banding\) on page 139](#).

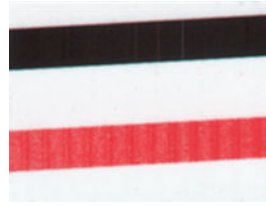

You can also see some banding in patterns 4, 9, 10, and 11, indicating that the printheads need to be cleaned. You can launch printhead cleaning from the front panel by touching , then **Image Quality Maintenance** > **Clean printheads**.

## Streaks

Looking at patterns A, B, C, G and H, you may find vertical streaks as in the examples shown below, if the printer's printheads are not working correctly. Replacing the printhead for the color showing the streaks may solve the problem.

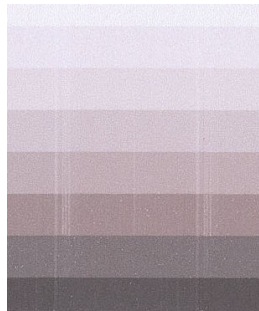

## Grain

Looking at patterns A, B, and C, you may find problems in the printer's paper advance or the printheads that cause visible grain in area fills. The following examples show this defect: original on the left, printed image on the right.

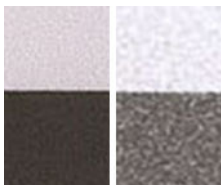
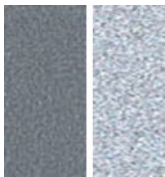

## Scan or copy the diagnostic plot

There are two options for evaluating the diagnostic plot: scanning into a JPEG file, or copying onto paper. We recommend using the scan option, so that the generated file can be analyzed more easily by a remote support engineer if necessary. If you decide to scan the plot, first adjust your computer's monitor as described in [Monitor calibration on page 172](#). Once you have scanned the diagnostic plot, please remember to open the scanned file in any image viewer software and select a zoom of 100% for correct visual evaluation of patterns.

If you decide to copy, make sure that a paper roll at least 36 in (914 mm) wide is loaded in the printer. Ideally, the same type of paper used to print the diagnostic plot should be used for copying it.

These are the settings that you should select:

### Scan

- Quality: 600dpi
- File type: JPG
- Compression: medium
- Paper type: photo or matte, according to the paper used to print the diagnostic plot. Use photo if in doubt

### Copy

- Content type: Image

Load the diagnostic plot into the scanner input tray, making sure that the printed side of the plot is facing up. The black arrows on the diagnostic plot indicate the direction of loading. Make sure that the diagnostic plot is loaded without skew, and it is centered (that is, it covers the whole scanner area).

Once you have scanned the diagnostic plot (in case you selected the scan option), please remember to open the scanned file in any image viewer software and select a zoom of 100% for correct visual evaluation of patterns.

## Monitor calibration

The monitor on which the plot is going to be evaluated should ideally be calibrated. As this is not always feasible, we propose here to follow an easy procedure for adjusting the brightness and contrast of the monitor in order to see the patterns correctly.

Adjust the brightness and contrast of your monitor until you can see a difference in lightness between these two squares:





Now you are ready to check each pattern individually.

### **Save the diagnostic plot for future use**

We recommend saving the diagnostic plot for future use.

## Scanner jam removal

When a paper jam occurs, a message about it appears in the front-panel display.

1. Open the scanner cover.

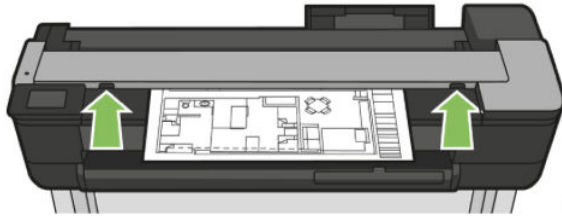

2. At the back, pull the media out from the top rear area.

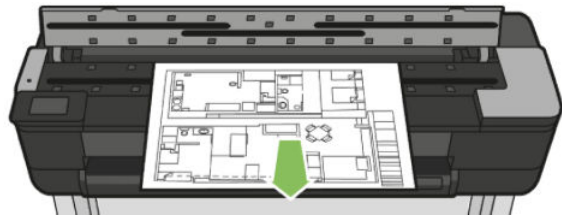

Or pull it from the front bottom area between the scanner platen and front window.



**⚠ CAUTION:** Do not move the paper sideways; it could damage the scanner!

Or pull it from the front bottom area between the scanner platen and front window.

3. Turn the rubber wheels with a finger in order to get better access to the paper, and remove any debris.



4. Close the scanner lid.

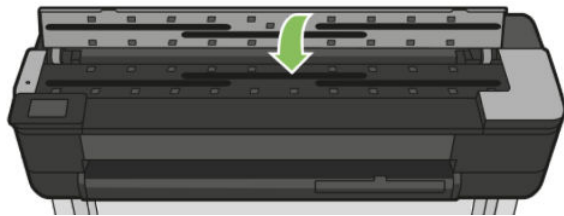

## Scan media does not load

In case the customer has difficulty loading the original please try the following troubleshooting:

1. Check that unit is on.
2. Make sure the unit has booted up completely and it is idle.
3. Check for any messages in the Front Panel.
4. If everything above is correct, please check the original meets the specs of the scanner capabilities.
5. Then, make sure to load the original far enough in so the scanner can sense it.
6. Try to smooth out the original leading edge or trim the leading edge so the media can travel nicely into the scanner.
7. Finally try with a different media type to discard scanner hardware issues.

## Update the firmware

There are various ways of downloading and installing firmware updates, as described below; you can choose whichever you find most convenient.

### Update the firmware automatically from the Front Panel

1. Ensure that the printer is connected to the Internet.
2. Touch , to go to **Web Services**.
3. Select **Automatic FW upgrade**.

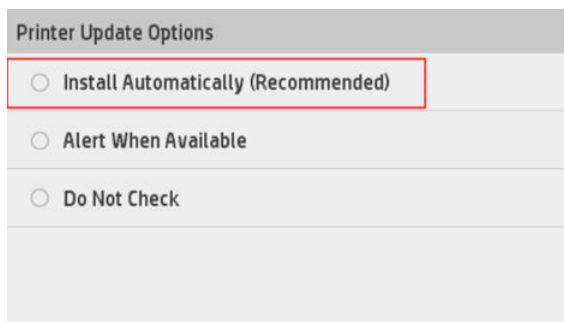

### Update the firmware from the Embedded Web Server

1. Ensure that the printer is connected to the Internet.

2. Go to **Print Quality Toolbox**.

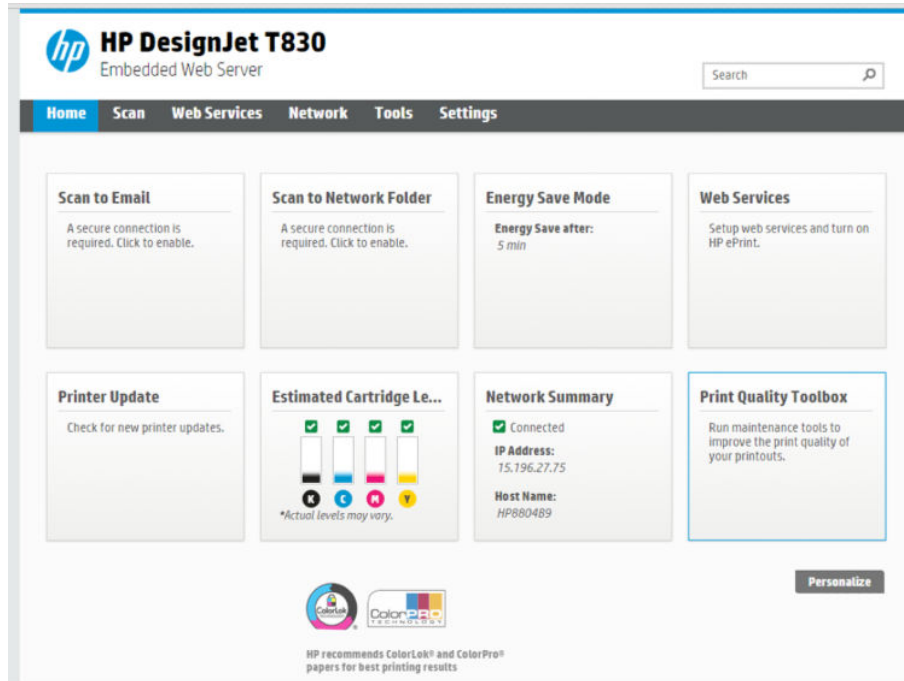

3. Select **Printer Update > Check Now**.

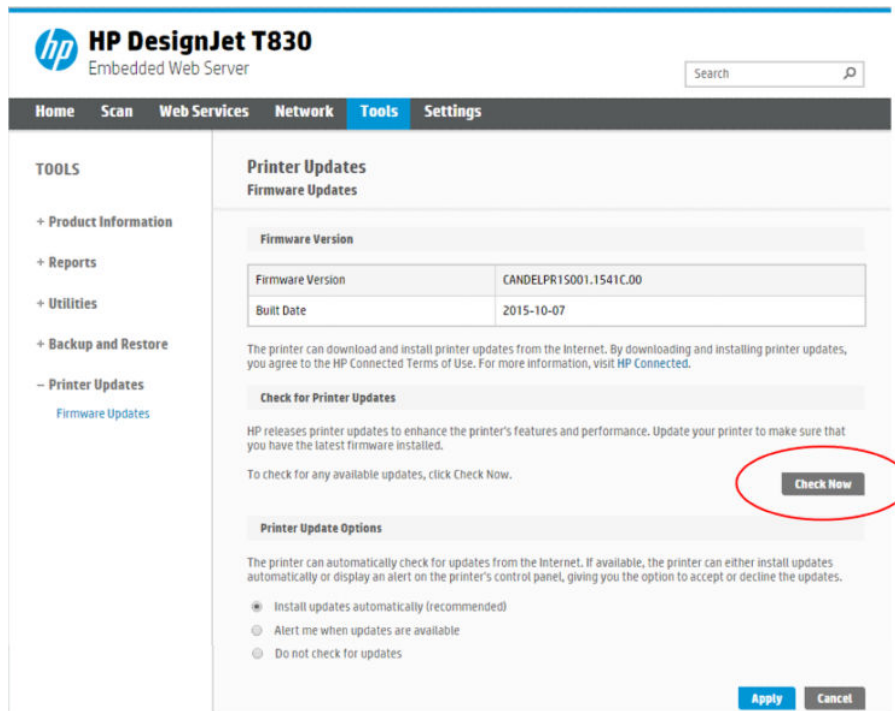

**Update the firmware from USB**

1. Download latest firmware file (.ful2) from the HP web site.
2. Copy the FUL2 file onto a USB flash drive (it must be FAT32 format).

3. Plug the USB pen drive into the printer.



 **IMPORTANT:** DO NOT remove the USB drive until the process is complete.

4. The firmware update option appears in the Front Panel.

 **NOTE:** The upgrade firmware option has a **40 second** delay. Please wait until the option appears in the Front Panel before proceeding.

 **NOTE:** If after the 40 seconds the unit does not read a firmware file from the USB pen, the option screen below will become unavailable and disappear.

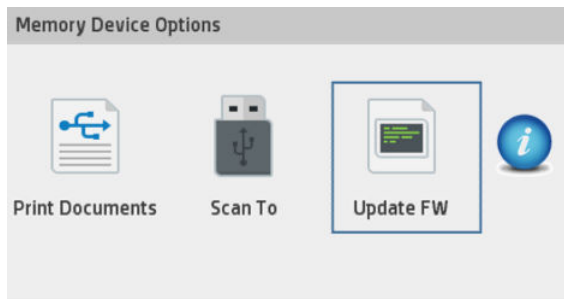

If there is a large amount of information on the USB pen, the printer may have struggled to read the firmware file before the 40 second time out, in this case:

- a. Ensure the USB is FAT32 format
  - b. Ask the customer to delete all information from the USB pen except the firmware update file.
5. After selecting, it will start automatically. During the firmware upgrade, the screen will remain black for an extended period of time (15 seconds) and it may look that printer has frozen.
  6. Check the firmware upgrade is successful in the Front Panel dashboard.

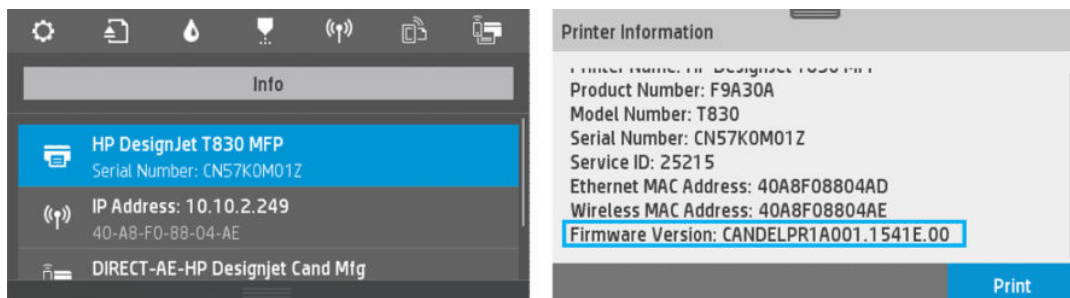

## Update the firmware from the HP (Designjet) Utility

1. Launch the HP Designjet Utility under Windows or the HP Utility under Mac OS.
2. Go to the **Admin** tab.

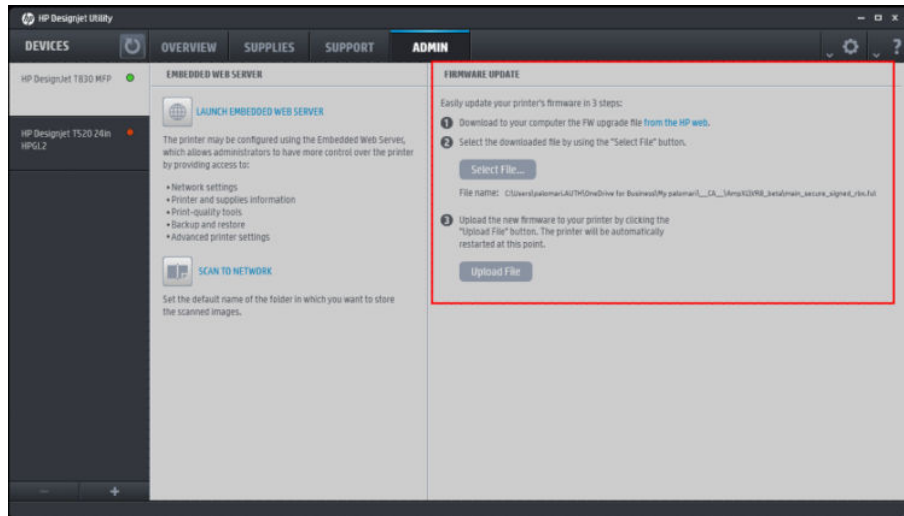

3. Download the firmware upgrade file.
4. Click **Select File** and a pop-up window to select the firmware upgrade file will appear.
5. Select the file (\*.ful2) and click **Open** button. Then the **Upload File** button will be enabled. Click it to start the firmware upgrade.

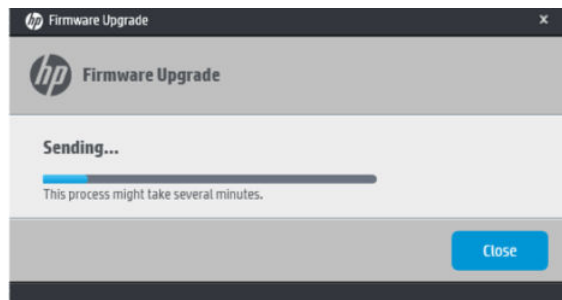

6. Once the file has been sent, a new pop-up is displayed.

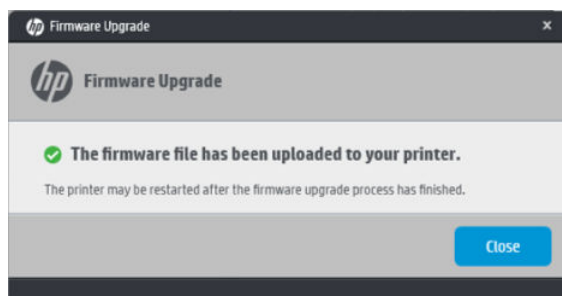

7. Press **OK**. The printer restarts to finish the firmware upgrade, and the printer status report is printed. Check that the firmware version is the latest.

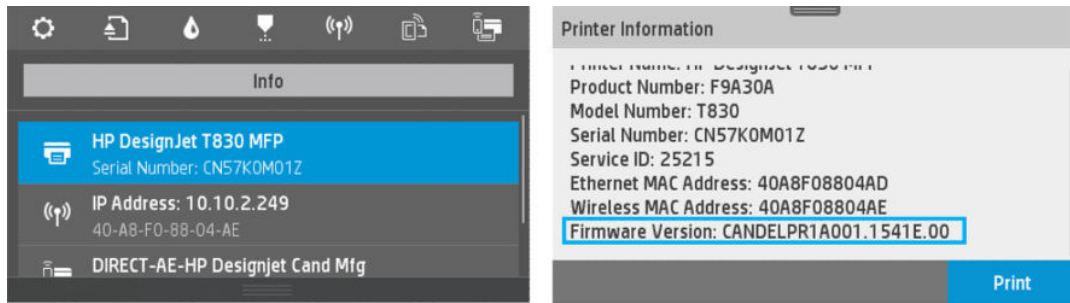



---

## 3 Support Menus, Diagnostic Plots & Calibrations

- [Support menus](#)
- [Entering the support menus](#)
- [Support menu](#)
- [Extended Support menu](#)
- [7. Scanner diagnostics \(included only in Extended Support Menu\)](#)
- [Diagnostic Plots & Calibrations](#)

## Support menus



In this chapter you will find an explanation in detail of each of the items included in the Support Menu and the Extended Support Menu. All these service options and utilities under the Support Menu are available to customers under the assistance of an HP call agent.

## Entering the support menus

There are two different menus, the Support Menu, used for customers following instructions by phone assisted by a **call agent** in order to troubleshoot an issue, and/or to access printer information when a customer has contacted HP for assistance; and the Extended Support Menu, accessible only by **service engineers** and used for troubleshooting, diagnosis during repair, calibrations, reset, and accessing printer information during a service operation.

### Entering the Support Menu for customers

Use the following procedure to enter into the Support menu.

1. The Support Menu for the customer is accessible from any screen by pressing the Power Button continuously for 15 seconds. This menu is also accessible from the Home screen by pressing: Back  / Back  / Back .
2. The following screen will display, select **Support Menu**.

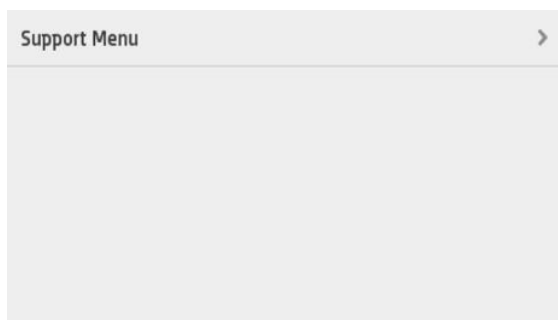

3. The following screen will display:

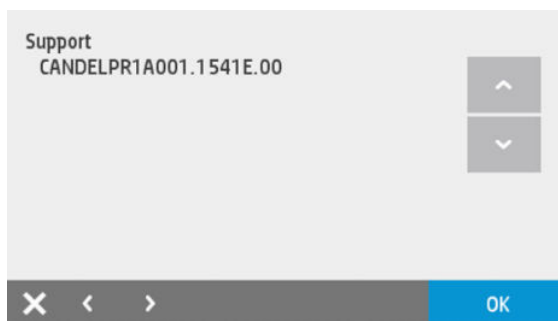

4. Navigate through the menu using the Up (↑) and Down (↓) arrows in the Front Panel display.

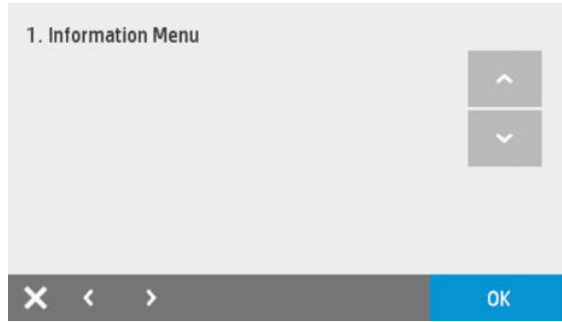

5. To go back to the previous level, use the Cancel (X) key.

### Entering the Extended Support Menu for service engineers

Use the following procedure to enter into the service engineer's Extended Support Menu.

1. This menu is accessible only by the service engineer and is called the Extended Support Menu, accessible from the Home screen by pressing: Home (🏠) / Back (⏪) / Home (🏠) / Home (🏠).

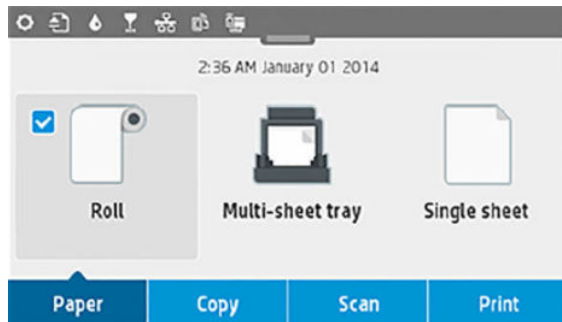

**NOTE:** The Extended Support Menu is accessible only from the Home screen. If there is a system error, you will not be able to access this menu. Therefore, to diagnose the issue, use the Support Menu for customers (by pressing the Power button continuously for 15 seconds). Once the printer is repaired, if you need access to this menu, do the resets or use the service utilities that are accessible only from this menu.

2. The following screen will display with the extended menu options:



3. Select the **Extended Support Menu** tab on Front Panel, the following menu will display:

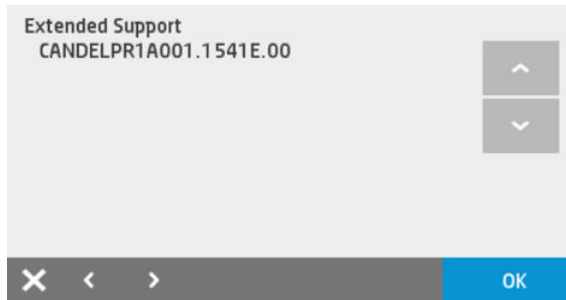

4. Navigate through the menu using the Up (^) and Down (v) arrows in the Front Panel display.

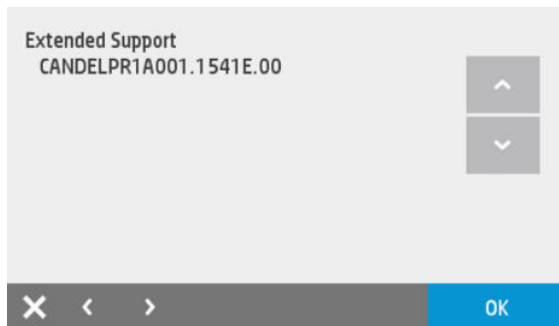

5. To go back to the previous level always use Cancel (X) key.

For information on the extra items in the Extended Support Menu, see [Extended Support menu on page 216](#).

# Support menu

In this section of the service manual you will find an explanation in detail of each of the menus included on the Support Menu. All these service options and utilities are available to customers under the assistance of an HP call agent. For a diagram of the menu tree, see [Support Menu and Extended Support Menu Tree on page 545](#).

## Information menu

### 1.1 Model number

Select this to get the printer's Model Number.

### 1.2 Serial number

Select this to get the printer's Serial Number.

### 1.3 Region/Language

Select this to get the printer's Country location and language setting.

### 1.4 Counters

Select this to get information about the number of pages printed and Carriage cycles.

### 1.5 Firmware version

Select this to get the printer's Firmware Version. The firmware version are identified by the week of year they are released. Example: FW name: xxxxxxxxx.1541F.xxxx

Where:

- 15 = Year
- 41 = Week
- F = Minor weekly revision

### 1.6 Error history

Select this to get the printer's last 50 system errors or asserts.



Navigate through the menu using the Up (↑) and Down (↓) arrows in the Front Panel display. The first error [0] is the oldest logged.

## 1.7 Printer region

Select this to get the printer region. Printer region is always "0".

## 1.8 Pen and Ink supply region

Select this to get the pen and Ink supply region. Supply region is always "1".

## 1.9 Pen and Ink supply serial number

Select this option to check the pen and Ink supply serial number.

## 1.10 Ink supply level

Select this option to check the status of the ink supply. (Pen refers to cartridge). "Ok" means cartridge is OK for use.

## Extra Printhead information (not included in the Service Menu)

Printhead install date and Printhead drop count can be retrieved from the standard menu. Simply go to the dashboard and key on the PHA icon.

Check this to get the PHA installation date, and use it to find out the PHA warranty.

Check printhead drop count to display the amount of ink fired (ml) by the printhead for each color. Also shows printhead warranty status.

\*Warranty Info Status can be:

- In Warranty
- Out of Warranty

## 1.11 – 1.14 Other items for manufacturing purposes

These tests pull data from the unit. No damage or reset can be triggered.

## 1.15 Wireless region

Select this to verify the wireless region. By default, it's configured to WorldSafe.

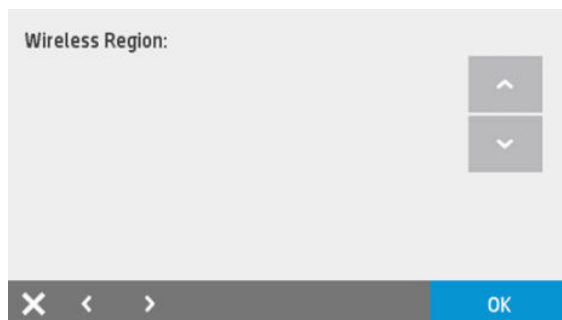

Press **OK**

## Reset menus

### 2.1 Country/language reset

Erases country and language settings. Printer will shut down and restart.

### 2.2 Soft reset

Erases all the custom user settings to their default values.

### 2.3 Hard reset

Erases all the settings and device self-calibrations including OOB. Clears wireless settings and web services.

### 2.4 Web Server password

Erases the password set in the Web Server.

### 2.5 OOB reset

Resets everything to factory default except Ink tubes and mandatory firmware upgrade.

### 2.9 Line feed mfg calibration

Deletes user media advance calibrations. Restores the manufacturing ones. Unit will power down and reboot.

## System configuration

### 3.2 Set boot mode to user mode

Sets the unit from manufacturing mode to “user mode”. This option should only be used if Front Panel shows a white grid (manufacturing mode).

## Print diagnostics menu

### 4.1 Nozzle test

#### Description

Prints the nozzle health pattern. While performing this test, paper is needed in the Multi-sheet tray. Also, it is required to be an A4 or Letter Size paper, or else there will be a paper size mismatch message. There will be an option to print anyway.

### 4.2 Bypass Pen alignment

#### Description

Skips printhead alignment during start up or printhead replacement. This can be useful for some troubleshooting.

### 4.3 Carriage servo

#### Description

This test verifies all the components associated with the Carriage servo subsystem: Carriage Motor, Encoder Strip, and Encoder Strip sensor (located on the Carriage PCA). When the test is done the Carriage is uncapped and moved outside the Service Station in order to check that all the components work properly or if any seems damaged.

### Associated errors

When any of the following errors occur in the printer, this diagnostics procedure must be performed:

- System error 0042-0117
- Printhead missing or damaged
- Carriage jam error during printer startup

### Procedure

1. From the Diagnostics menu, select **4.3 Carriage Servo** and then **OK**. (After pressing OK screen remains the same until test is complete.)

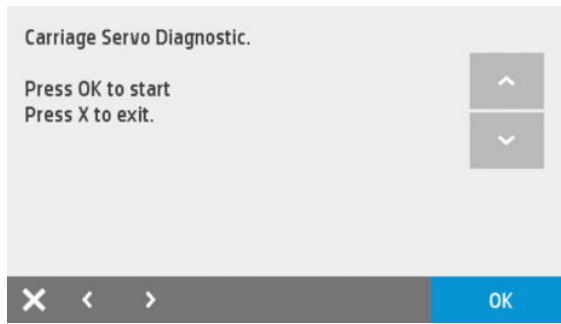

2. The Carriage will be uncapped and moved outside the Service Station. If everything is fine the following screen will be displayed:

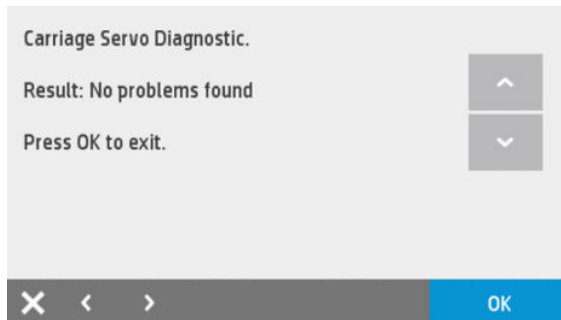

3. If there is a failure you will see one of these system errors: 0042-0117, 0942-0188, 0002-0001.

## 4.4 Paper servo

### Description

This test verifies all the components associated with the Paper servo Subsystem: Paper Motor, Feed Encoder Disk, Feed Encoder PCA, and Index Encoder PCA. When the test is done the feed roller is moved a small distance in both directions in order to check that all the components work properly or if any is damaged.

### Associated errors

When any of the following errors occur in the printer, this diagnostics procedure must be performed:



- System error 0041-0117
- Paper jam error

### Procedure

1. From the Diagnostics menu, select **4.4 Paper Servo** and then **OK**.

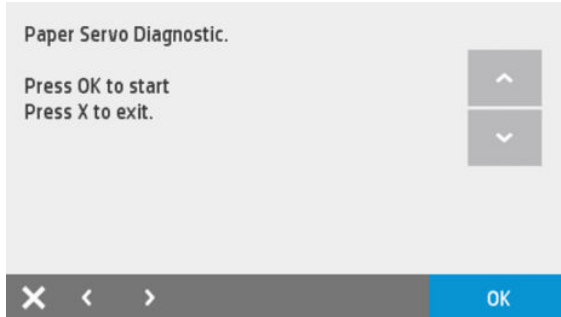

2. Open the Top Cover and press **OK** again to verify if the feed roller is moving.

**TIP:** If there is no roll paper loaded and in order to check easily if the feed roller is moving or not you can introduce a paper sheet into the top input slot (where single sheets are loaded see below) if the feed roller moves correctly you will see the paper moving up and down.

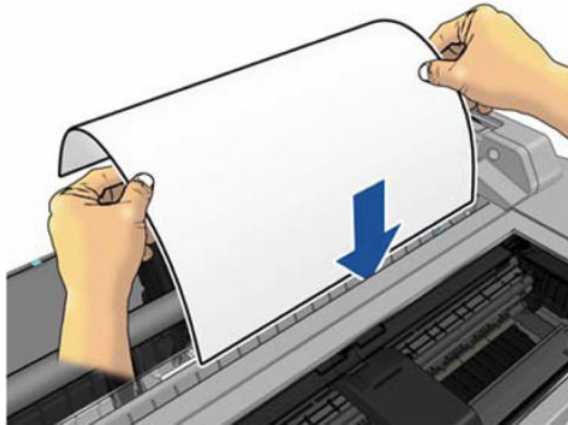

3. The feed roller will be moved a bit in both directions. If everything is fine the following screen will be displayed:

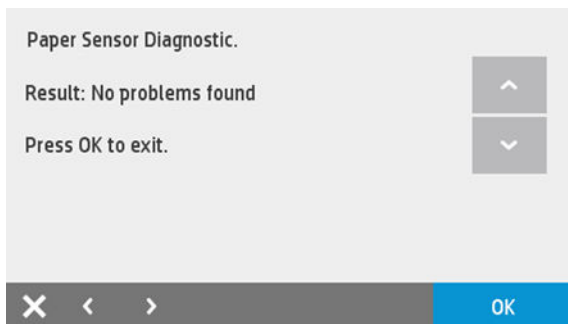

4. If there is a failure you will see one of these system errors: 0041-0117, 0085-0101, 0085-0201.

## 4.5 Out-Of-Paper Sensor

### Description

This test verifies the Out-Of-Paper Sensor. When this test is done you will be asked to introduce a single sheet to check that the sensor is not damaged.

### Associated errors

When any of the following errors occur in the printer, this diagnostics procedure must be performed:

- The printer is not able to complete the load because it cannot detect the paper.
- The printer shows in the Front Panel that the paper is loaded although there is not any paper loaded.

### Procedure

1. From the Diagnostics menu, select **4.5 Out-Of-Paper Sensor** and then **OK**.

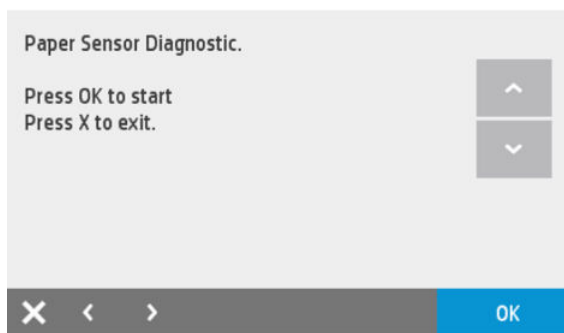

2. Press **OK** again to start the test, the following screen will display. Load paper as in single sheet feed (recommendation is A4 size or larger):

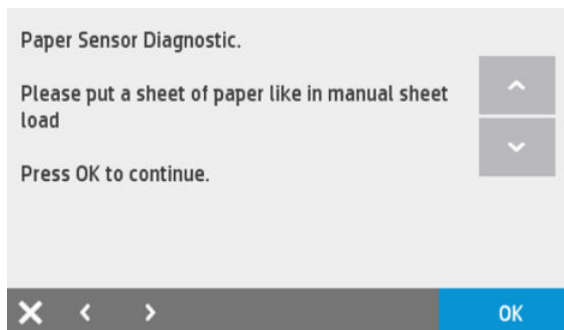

3. Insert the paper sheet and press **OK**. The screen message will change for this:

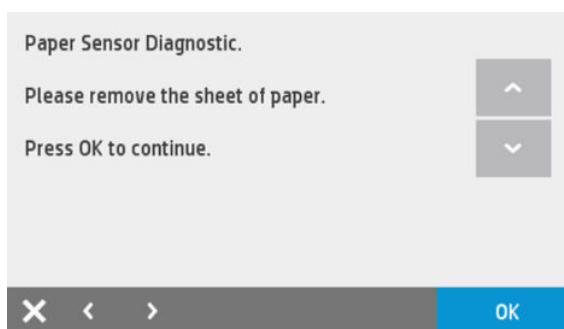

4. Remove the paper and press **OK**. If the sensor is not damaged then you will see:

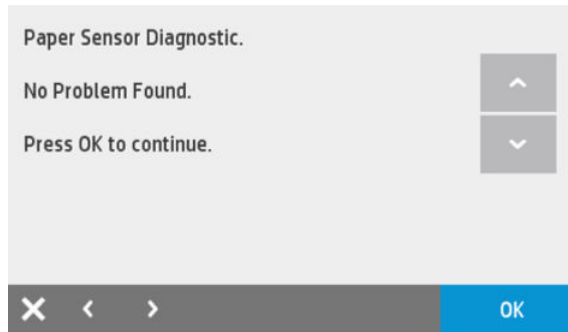

5. If the sensor does not work properly there will be the following error:

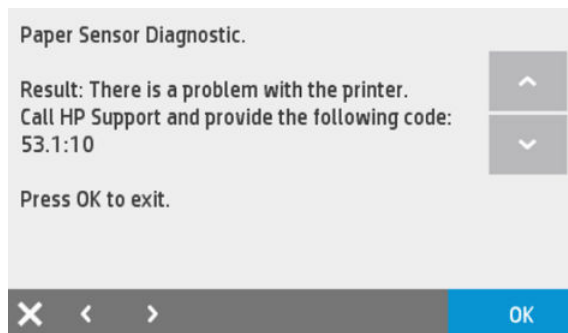

6. Replace the OOP, see [Out-Of-Paper Sensor on page 388](#).

## 4.6 Output Tray Sensor

### Description

This test verifies the Output Tray Sensor. When this test is done you will be asked to open and close the Output Tray door to check that the sensor is not damaged.

### Associated errors

When any of the following errors occur in the printer, this diagnostics procedure must be performed:

- The printer shows the animation "Close Output Tray Sensor" when trying to load or print from roll although the tray is closed.

### Procedure

1. From the Diagnostics menu, select **4.6 Output Tray Sensor** and then **OK**.

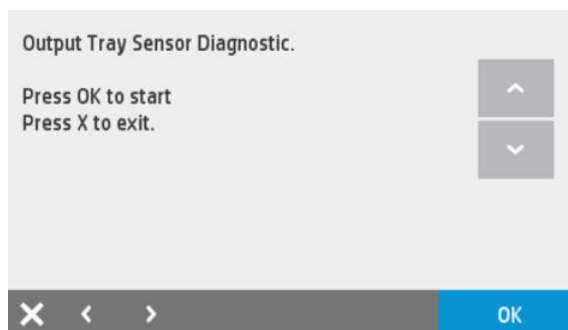

2. Press **OK** again to start the test, the following screen will display:

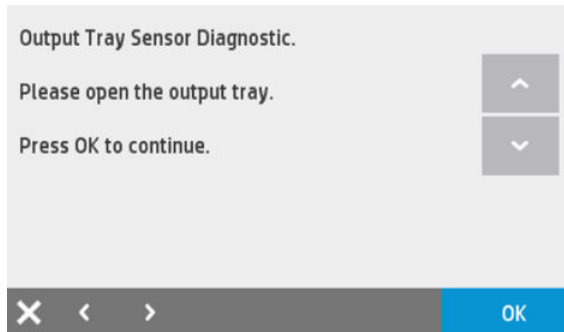

3. Open the Output Tray and press **OK**. The screen message will change for this:

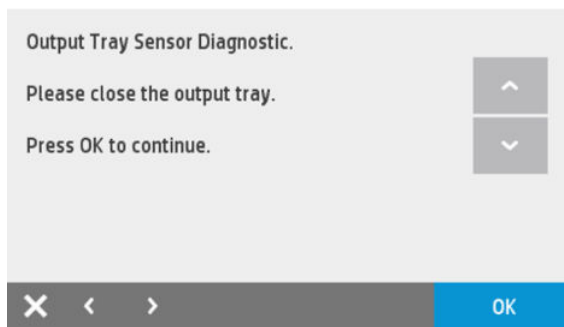

4. Close the Output Tray and press **OK**. If the sensor is not damaged then you will see:

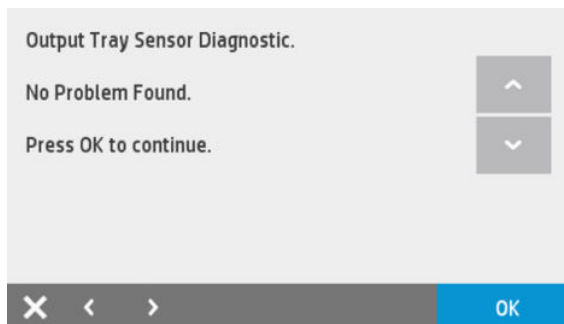

5. If the sensor does not work properly replace the Output Tray Sensor, see [Output Tray Sensor Assembly on page 395](#).

## 4.7 Line Sensor (or ZIM, Spot sensor)

### Description

This test verifies the Line Sensor. When this test is done you will be asked to load paper into the Multi-Sheet Tray in order to check that the sensor is not damaged.

### Associated errors

When the following error occurs in the printer, this diagnostics procedure must be performed:

- The printer is unable to complete the load because it cannot detect the paper.

### Procedure

1. From the Diagnostics menu, select **4.7 Line Sensor** and then **OK**.

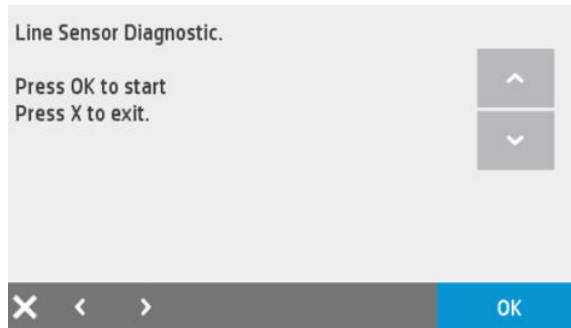

2. Press **OK** again to start the test, the following screen will display:

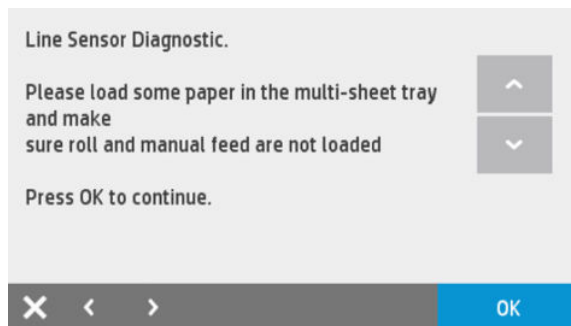

3. Check that there is paper in the Multi-Sheet Tray and the roll is unloaded and press **OK**. Then one sheet will be loaded to perform the test. If the test is correctly done you will hear 3 beeps, and the paper will be unloaded to finish the test, and the following will be displayed:

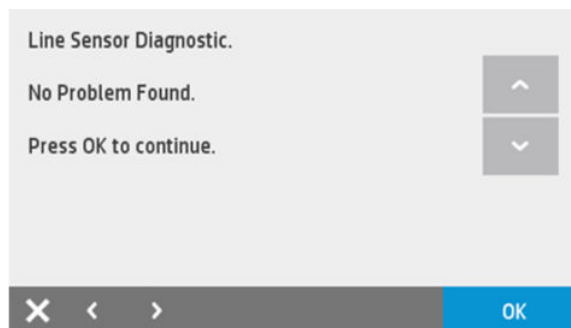

4. If the sensor is not working properly the system error 0955-0050 will appear. The Line Sensor should be replaced, see [Carriage Line Sensor on page 402](#).



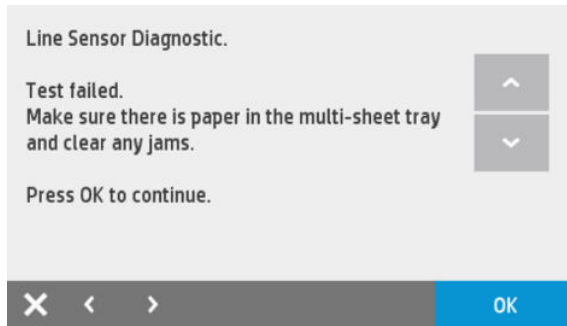



5. If the Multi-Sheet Tray is empty or the paper cannot be loaded, you will see the following screen:



6. If the test fails:
- Check that there is no paper jam preventing the sheet loading process. Remove the Multi-Sheet Tray if necessary.
  - Perform the OOP sensor diagnostics to be sure that the Paper Sensor works correctly, see [4.5 Out-Of-Paper Sensor on page 190](#).

## 4.8 Display frame keys

### Description

This test verifies all the keys in the Front Panel frame: Home , Help , Left arrow , Right arrow , Back , Cancel , and the Power key located on the right of the Front Panel. When this test is done you are asked to press these keys one by one to check whether any are damaged.

### Associated errors

When the following error occurs in the printer, this diagnostics procedure must be performed:

- One or more keys are unresponsive.

### Procedure

- From the Diagnostics menu, select **4.8 Display Frame keys** and then **OK**.
- The following screen will display:

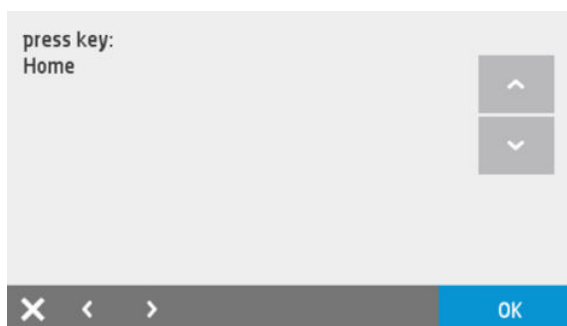

- Check that the Cancel key is on and press it, then the screen will change automatically to the next key (Home). Check again that the Home key is on (the icon should be illuminated), press this key and then one by one through all the keys. The last one is the Power key.

4. If you press all the keys and they work correctly you will see:

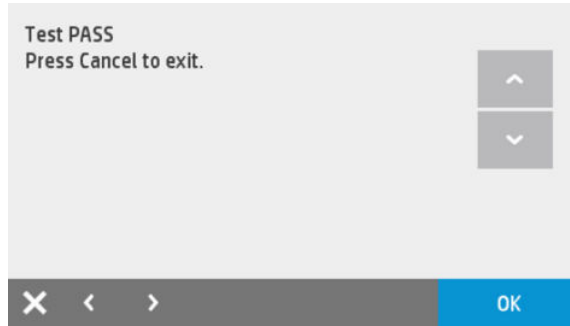

5. If any key does not work, the diagnostic will not pass to the next key, and will stay always in the screen of the failing key therefore the front panel should be changed, see [Front Panel SFP F9A29-67008 on page 278](#). To recover the printer, if this occurs the printer should be restarted by switching it off and on with the power key.

## 4.9 Display

### Description

This test verifies that the Front Panel display works OK.

### Associated errors

When any of the following errors occur in the printer, this diagnostics procedure must be performed:

- There is no specific error associated with a failure of some pixels or the backlight of the Front Panel. This diagnostic should be run when we want to check if the front panel display is OK, or if the Front Panel does not respond.

### Procedure

1. From the Diagnostics menu, select **4.9 Display** and then **OK**.
2. The following screen will display:

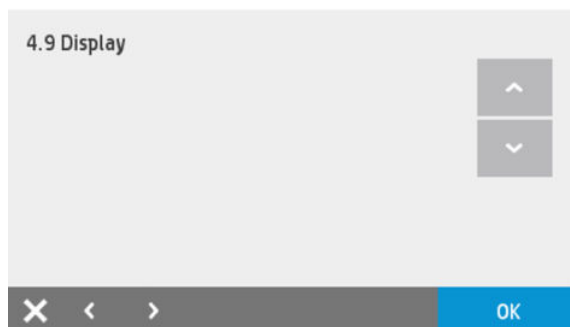

3. Press **OK** several times. Each time that **OK** is pressed the display color will change.

4. Once the test is finished you will see:

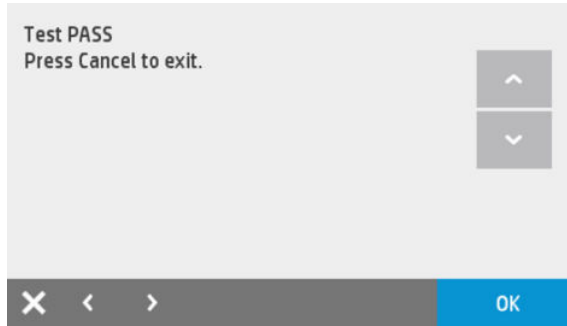

## 4.10 RTC battery status

### Description

This test checks whether the Real-Time Clock's battery has expired.

### Associated errors

There is no error. The symptom is that the date and time is lost when the power cord is disconnected. To check that the battery is OK perform this diagnostic following the procedure below.

### Procedure

1. Switch off the printer and remove the power cable.
2. Wait for 20 seconds.
3. Reconnect the power cord and turn on the printer.
4. From the Diagnostics menu, select **4.10 RTC Battery Status** and then **OK**.
5. The following screen is displayed:

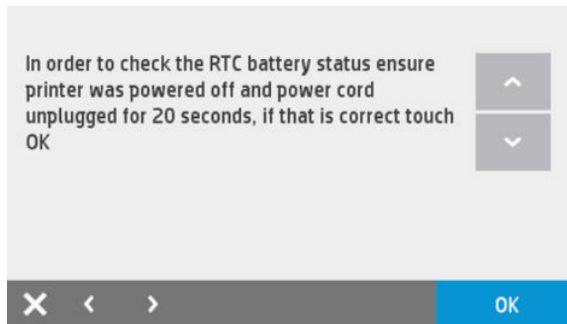



6. If test passes the following screen is shown:

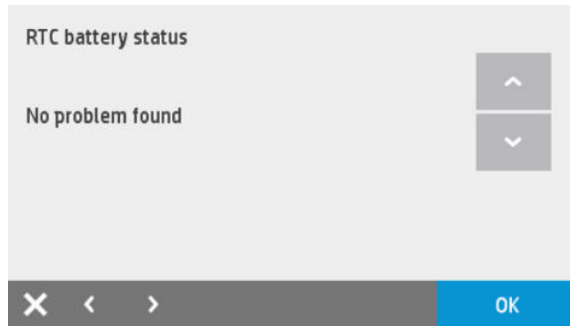

7. If the battery is exhausted the following message is displayed:

**Problem found: Battery expired or RTC problem. Call HP support and provide the following code: 0001-0082**

## 4.11 Service Station

### Description

This test verifies the mechanical components of the Service Station to check whether there is any anomaly (such as a mechanical blockage, a broken gear, etc.).

### Associated errors

This test is used for manufacturing purposes.

### Procedure

1. From the Diagnostics menu, select **4.11 Service Station** and then **OK**.
2. The following screen is displayed:

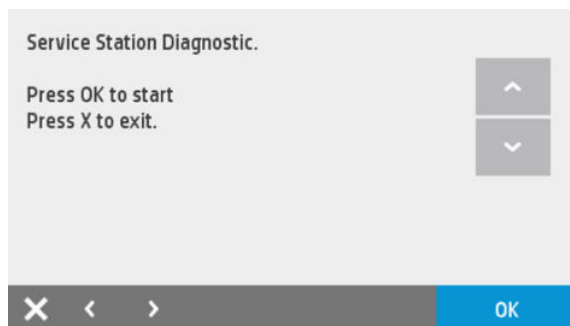

3. Press **OK** to perform the test, if everything is OK the following screen is displayed.

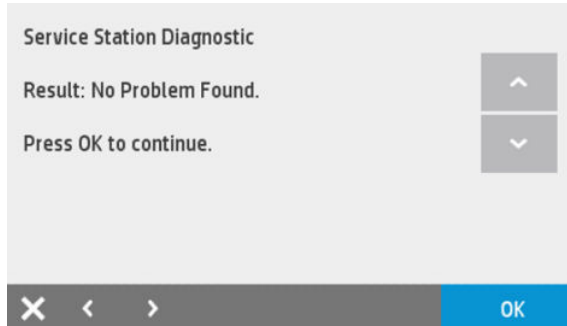

## 4.12 ISS

### Description

This test verifies the mechanical components of the ISS to check whether there is any anomaly (such as a mechanical blockage, sensor failure, etc.).

### Associated errors

This test is used for ISS verification.

### Procedure

1. From the Diagnostics menu, select **4.12 ISS** and then **OK**.
2. The following screen is displayed:



3. Press **OK** to perform the test, if everything is OK the following screen is displayed.

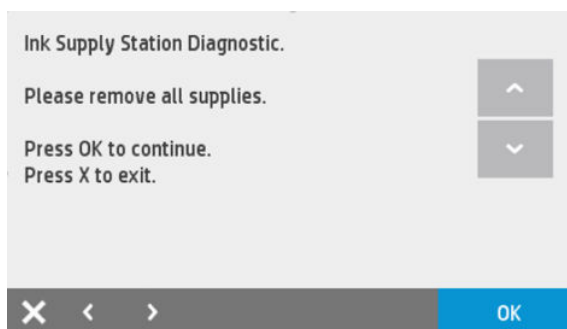

4. Remove the supplies and press **OK** to perform the test, if everything is OK the following screen is displayed.

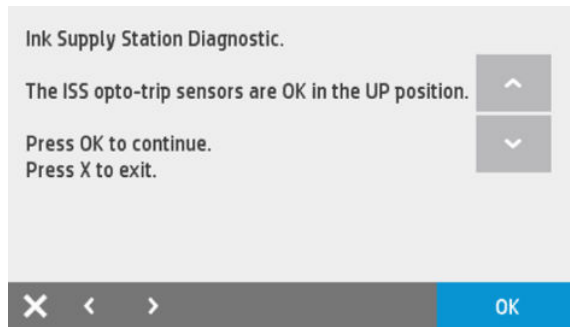

5. Press **OK** and the following screen is displayed.

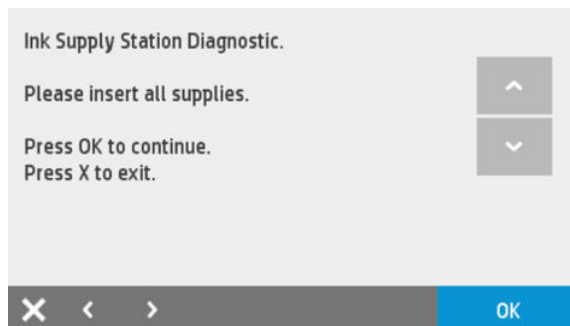

6. Insert the supplies and press **OK** to perform the test, if everything is OK the following screen is displayed.

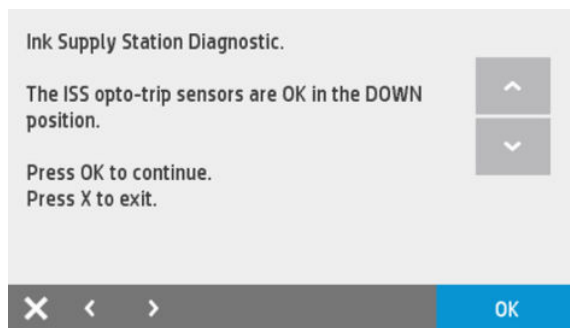

## 4.13 Rewinder motor

### Description

This test verifies all the components associated with the Rewinder motor and Rewinder Encoder Disk. When the test is done the rewinder motor turns a small distance in both directions in order to check that all the components work properly or if any is damaged.

### Associated errors

This test should be conducted when there are issues unloading the roll or media advance problems affecting IQ.

### Procedure

1. Unload roll.
2. From the Diagnostics menu, select **4.13 Rewinder Motor** and then **OK**.
3. The following screen is displayed:

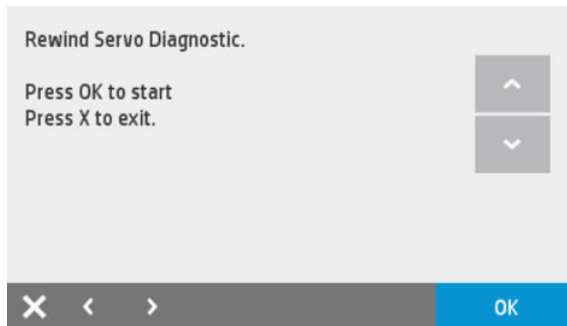

4. Press **OK** to perform the test, if everything is OK the following screen is displayed.

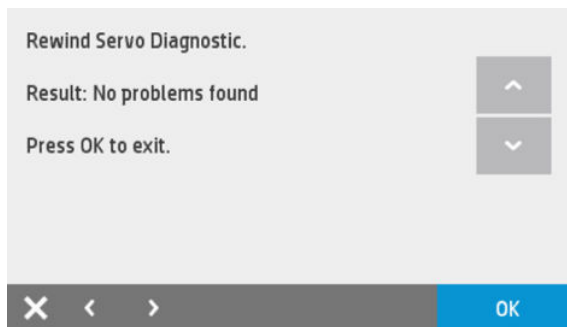

#### 4.14 Additional Manual Sensor Test (not included in the Service Menu)

- Ink door sensor
- PHA door sensor
- Top/front cover sensor
- Multisheet Tray Sensor

All these sensors can be checked through the normal UI.

**Ink door sensor:** Printer with door open should report a "Replace Ink cartridges screen". With door closed, it should report the home screen.

**Top/Front door open:** Printer with top/front door open should report the Door open screen. With top/front door closed, it should report the home screen.

**PHA door sensor:** Printer with PHA door open should report the "Close Printhead Door" screen. With PHA door closed, it should report the home screen.

**Multisheet Tray sensor:** With Multi-Sheet Tray open and removed, the printer should report that the Multi-sheet tray is detached. Once it is placed at the rear part of the printer, it should report that the multi-sheet tray is attached.

## Connectivity Diagnostics

### 5.1 Connectivity report

Prints a report that contains all the various Connectivity settings.

# HP DesignJet T830 MFP series Connectivity Status

Serial Number: CN57K0M01Z

## [ Networking ]

Printer Name: HP8804AD; Active DNS Server(s): 10.10.0.1; Active Default Gateway: 10.10.0.1; MAC Policy: Multiple Hot Multiple MAC

### ---- Network Interface Adaptor Summary ----

Name	Type	Status	MAC Address
eth0	Wired (802.3)	Off	40:a8:f0:88:04:ad
wlan0	Wireless (802.11)	Connected	40:a8:f0:88:04:ae
wlan1			42:a8:f0:88:84:ae

### ---- IP Status ----

Name	Type	Addr. Source	IP Address	Subnet Mask	Gateway	DNS Server(s)
eth0	Wired (802.3)	Off				
wlan0	Wireless (802.11)	DHCP	10.10.2.249	255.255.248.0	10.10.0.1	10.10.0.1
wlan1		DHCP	192.168.223.1	255.255.255.0	10.10.0.1	10.10.0.1

Note: Automatic or manual IP address assignment only occurs for an adaptor if it is currently connected.

### Wired (802.3) Adaptor Information Detail

```

----- Configuration -----
Enabled at power on: yes                    Link Config: Auto link speed
Auto Crossover: On                          Auto or Manual IP Address: Automatic
Auto or Manual DNS Server: Automatic

----- Status -----
Adaptor Name: eth0                           Adaptor State: Off
Adaptor Connection Active: False             Adaptor MAC Address: 40:a8:f0:88:04:ad
Link Status: 10 Mbs Half Duplex

```

### Wireless (802.11) Adaptor Information Detail

```

----- Configuration -----
SSID: 'hpguest'                               Mode: Infrastructure, enabled at power on
Regulatory Domain: Unconfigured - legal everywhere Max. Power Level: 1000mw
Authentication: Open                           Encryption: None
High Speed Mode: Disabled                       Fragmentation Threshold: 2346 (default is 2346)
RTS Threshold: 2347 (default is 2347)          Max. Transmit Rate: Automatic
Beacon Period: 100ms                           ATIM Window: 0ms
IBSS Always Up: off                             Infrastructure 802.11b only: off
Ad hoc 802.11b only: off                       Auto or Manual IP Address: Automatic
Auto or Manual DNS Server: Automatic

----- Status -----
Adaptor Name: wlan0                           Adaptor State: Connected
Adaptor Connection Active: True                Adaptor MAC Address: 40:a8:f0:88:04:ae
Radio Hardware Status: Radio Detected          Permanent MAC Address: 00:00:00:00:00:00
Board Rev: 00002332 Board ID: 0000067c        Radio Firmware Revision: 18.198.20.06
Association Attempt Info: Associated Successfully Completion Time: 00:00:00.0
Association State: Associated                   WPS Status: Ready To Run
Signal Strength: -58dBm, good                 Link Speed: 2 mbps
BSSID In Use: ac:16:2d:e5:f4:33               Channel Used: 11
Channels Available: 1, 2, 3, 4, 5, 6, 7, 8, 9, 10

```

### UnDirected Scan - Wireless networks found = 16

Discovered SSID	Mode	BSSID	Channel	Privacy	Auth	Encrypt	RSSI	WPS
'hpin'	Access Pnt	ac:16:2d:e5:f4:31	11	RSN	WPA2-Ent.	AES/TKIP	-56	No
'hpinetnet'	Access Pnt	ac:16:2d:e5:f4:34	11	RSN	WPA2-Ent.	AES/TKIP	-56	No
'hpe'	Access Pnt	ac:16:2d:e5:f4:30	11	RSN	WPA2-Ent.	AES/TKIP	-57	No
'hp'	Access Pnt	ac:16:2d:e5:f4:32	11	RSN	WPA2-Ent.	AES/TKIP	-58	No
'hpinetnet'	Access Pnt	a0:d3:c1:9f:bb:14	11	RSN	WPA2-Ent.	AES/TKIP	-58	No
'hpguest'	Access Pnt	ac:16:2d:e5:f4:33	11	Disabled			-59	No
'hpin'	Access Pnt	a0:d3:c1:9f:bb:11	11	RSN	WPA2-Ent.	AES/TKIP	-59	No
'hpinetnet'	Access Pnt	a0:d3:c1:a0:e7:d4	11	RSN	WPA2-Ent.	AES/TKIP	-59	No
'hpe'	Access Pnt	a0:d3:c1:9f:bb:10	11	RSN	WPA2-Ent.	AES/TKIP	-60	No
'hp'	Access Pnt	a0:d3:c1:a0:e7:d2	11	RSN	WPA2-Ent.	AES/TKIP	-60	No
'hpe'	Access Pnt	a0:d3:c1:a0:e7:d0	11	RSN	WPA2-Ent.	AES/TKIP	-61	No
'hpguest'	Access Pnt	a0:d3:c1:9f:bb:13	11	Disabled			-61	No
'hpguest'	Access Pnt	a0:d3:c1:a0:e7:d3	11	Disabled			-62	No
'hpe'	Access Pnt	ac:16:2d:e5:c4:30	11	RSN	WPA2-Ent.	AES/TKIP	-63	No
'hpin'	Access Pnt	a0:d3:c1:9f:be:91	11	RSN	WPA2-Ent.	AES/TKIP	-64	No
'hp'	Access Pnt	ac:16:2d:e5:b4:52	11	RSN	WPA2-Ent.	AES/TKIP	-65	No

### Directed Scan: 'hpguest' - Wireless networks found = 11

Discovered SSID	Mode	BSSID	Channel	Privacy	Auth	Encrypt	RSSI	WPS
'hpguest'	Access Pnt	ac:16:2d:e5:f4:33	11	Disabled			-57	No
'hpguestnet'	Access Pnt	a0:d3:c1:a0:e7:d3	11	Disabled			-60	No
'hpguest'	Access Pnt	a0:d3:c1:9f:bb:13	11	Disabled			-60	No
'hpguest'	Access Pnt	ac:16:2d:e5:c4:33	11	Disabled			-64	No
'hpguestnet'	Access Pnt	a0:d3:c1:9f:be:93	11	Disabled			-66	No
'hpguest'	Access Pnt	a0:d3:c1:a0:da:b3	11	Disabled			-68	No
'hpguest'	Access Pnt	a0:d3:c1:a0:e8:13	11	Disabled			-70	No
'hpguestnet'	Access Pnt	ac:16:2d:e5:e4:b3	11	Disabled			-73	No
'hpguest'	Access Pnt	ac:16:2d:e5:59:53	11	Disabled			-79	No
'hpguest'	Access Pnt	a0:d3:c1:9f:bf:13	11	Disabled			-81	No
'hpguest'	Access Pnt	a0:d3:c1:a0:e8:53	11	Disabled			-82	No

## [ Network Troubleshooting Agent (version 2006.0) ]

Key to messages:

I - Informational: The condition MAY be IGNORED but might be of interest.  
W - Warning: The condition MUST be UNDERSTOOD because it MIGHT be a problem.  
F - Fatal: The condition MUST be CORRECTED because it WILL prevent network connectivity with the printing device.

W 00500: wlan0 There were 16 access points (APs) (or wireless repeaters) with your configured SSID (hpguest) found in the area. The printing device will connect to the one with the strongest signal.

If you've set up a network with multiple APs this is a normal condition. Note that the APs must be connected to the same LAN, usually via a wired connection. A special case is a wireless repeater which is an AP but uses a wireless connection to connect to

## 5.2 Wireless diagnostics test

Performs the same Wireless Diagnostics Test as in the "Customer UI", through the Front Panel of the printer. This diagnostic tool tests the wireless setup of the product.

## WIRELESS NETWORK TEST RESULTS

Model : HP DesignJet T830 MFP

**ATTENTION** *More than one access point/wireless router has been found that matches your wireless network name (SSID). If this is not intended, your HP printer may connect to the wrong wireless network. To avoid this, change your wireless network name (SSID) to be unique.*  
*If you change your network name, you will need to configure the SSID on all wireless devices to match your new network SSID.*

---

---

## DIAGNOSTICS RESULTS

---

### > Wireless

-- Wireless On	PASS
-- Wireless Working	PASS
-- Signal Quality	Excellent

### > Connectivity

-- Connected	PASS
-- Disconnect count total	4
-- Disconnect count (last hour)	0
-- Disconnect count (last 24 hours)	0

### > Network

-- Network Name (SSID) Found	PASS
-- Other networks detected matching your network name (SSID)	Yes
-- Wireless Networks Detected	45

### > Settings

-- Printer Settings Consistent with Wireless Router Settings	PASS
-- No Filtering	PASS
-- Channel	11
-- Security	PASS

## CURRENT CONFIGURATION

---

-- <b>Network Name (SSID)</b>	<b>hpguest</b>
-- Hardware Address (MAC)	40:a8:f0:88:04:ae
-- IP Address	10.10.2.249
-- Configuration Source	DHCP
-- Communication Mode	Infrastructure
-- Authentication Type	Open System
-- Encryption	None
-- Internet	Connected

For additional help with troubleshooting, refer to the network troubleshooting help section provided with your HP printer.

For more information on your network configuration, print the Network Configuration Page.

Visit the HP Wireless Printing Center - [www.hp.com/go/wirelessprinting](http://www.hp.com/go/wirelessprinting).

## 5.3 Print wireless metrics

Prints details on disconnect counts, disconnect duration, signal strength, noise levels, wifi frame lost details etc.

**WIRELESS METRICS DATA REPORT**  
**HP DesignJet T830 MFP series**  
 Firmware Revision: CANDELPR1A001.1541F.00

---

**Connectivity Details (In Nos)**

Disconnect count total	4
Disconnect count (last hour)	0
Disconnect count (last 24 hours)	0

---

**Disconnect Duration for Last 24 Hour (In Seconds)**

Minimum Disconnect Duration	NA
Average Disconnect Duration	NA
Maximum Disconnect Duration	NA

---

**Signal Strength Details (In RSSI)**

Range: -200(very very weak) to 20(strong)

Minimum RSSI Value (Last One hour)	-60
Average RSSI Value (Last One hour)	-58
Maximum RSSI Value (Last One hour)	-57
Minimum RSSI Value (Last 24 hour)	-60
Average RSSI Value (Last 24 hour)	-58
Maximum RSSI Value (Last 24 hour)	-57
Current RSSI Value	-57

---

**Signal Noise Level Details**

Minimum Noise Value (Last One hour)	-86
Average Noise Value (Last One hour)	-88
Maximum Noise Value (Last One hour)	-90
Minimum Noise Value (Last 24 hour)	-86
Average Noise Value (Last 24 hour)	-88
Maximum Noise Value (Last 24 hour)	-91
Current Noise Value	-88

---

**Wireless Frame Lost Details**

Frame Lost Count (Last One hour)	0
Frame Lost Count (Last 24 hour)	0

---

Regulatory Domain:

Unconfigured - legal everywhere

---

**IP Address Usage History (Recent First)**

IP Address	Channel	Config Mode	Duration	Allocation Time
10.10.2.249	11	DHCP	NA	1 Hr 4 Mi 2 Sec
10.10.2.249	11	DHCP	NA	1 Hr 4 Mi 2 Sec



## Reports

After printing a report the printer will return to the normal printer menu. If you want to continue in the support menu you will have to enter again.

In some cases there is a delay between the moment when you press **OK** in the support menu and when the printer starts to print the report. Please be patient.

### 6.1 Printer status report

A high level view of the product status.

## Printer Status Report

### Product Information

1. Model Name: HP DesignJet T830 MFP
2. Model Number: T830
3. Serial Number: CN57K0M01Z
4. Product Number: F9A30A
5. Service ID: 25215
6. Printer Zone (PX): 0
7. Firmware Version: CANDELPR1A001.1541F.00
8. FW Patch Version: 0
9. Country/Region: 15 / 1
10. ADF: Installed





### Print Usage Information

11. Total Pages Printed: 53
12. Total Color Pages Printed: 38

### Ink Delivery System Information

25. Ink Supply:
26. Estimated Ink Level:

27. Cartridge Number:
28. End of Warranty Date (Y-M-D):
29. First Installation Date (Y-M-D):
30. Ink Zone:
31. USE:
32. HP:
33. Supported Ink Cartridges\*:

Black	Cyan	Magenta	Yellow
			
HP 728 300ML	HP 728 130ML	HP 728 130ML	HP 728 130ML
2017/08/25	2017/08/25	2017/08/25	2017/08/25
2015/07/30	2015/07/30	2015/07/30	2015/07/30
1	1	1	1
0	0	0	0
1	1	1	1
HP 728 69ML	HP 728 40ML	HP 728 40ML	HP 728 40ML
HP 728 300ML	HP 728 130ML	HP 728 130ML	HP 728 130ML
HP	HP 728 300ML	HP 728 300ML	HP 728 300ML

\*\*Not all cartridges are available in all regions.

### Print Head Information

34. Pen ID  
(17 - 16) 0x00000000 00000000  
(15 - 11) 0x00000000 00000000 00000000 00000000 00000000  
(10 - 06) 0x00000000 00000000 00000000 00000000 00000000  
(05 - 01) 0x00000004 50412000 000058a0 c000004c 001357df
35. PHA Install Date In This Printer  
2015/08/05
36. HP:  
1
37. Part number  
HP 729 (F9J56A)
38. Total Drop Count (ml):  
Black: 13      Cyan: 8      Magenta: 7      Yellow: 10

### Additional Assistance

For more information about how to change settings and diagnose problems, see the user documentation for your device. This documentation is available on your computer after you install the software—either from the HP DesignJet T830 MFP Printer Software (Windows) or the Help Viewer (Mac OS).

### Wireless Network Test

To verify your product is setup correctly for Wireless, run the Wireless Network Test. You can access this test from the device control panel.

## 6.2 Extended self test

Includes printhead specific info.

## Extended Self-Test Report

HP DesignJet T830 MFP

Serial #: CN57K0M01Z

Language: 1

Device: 6, 0

Vertical Cartridge-to-Cartridge Alignment Setting: 32767

Horizontal Cartridge-to-Cartridge Alignment Setting: 32767

Black Bidirectional Printing Alignment Setting: 32767, 32767, 32767

Color Bidirectional Printing Alignment Setting: 32767, 32767, 32767

Service ID #: 25215

Country/Region: 15

ADF Detected

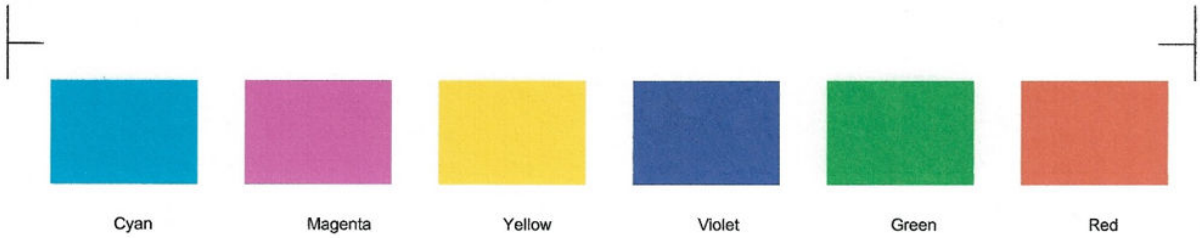

Total Page Count: 63



-- 5 Pt Font--

Extended Self Test Report

Product Number: F9A30A

Copy Page Count: 1

Pen Ambient Temp: 210

Main Digital ASIC Revision: NEURON Rev A.3 Mfg: ST

Other PCA Revision(s): Not Available

-- 5 Pt Font--

Number Power Cycles: 101

Scan Page Count: 30

Firmware Version: CANDELPR1A001.1541F.00-0

Main PCA Revision: 0x582e

counts at off = 10

-- 5 Pt Font--

Total Engine Page Count: 63

Last System Error Code: 02C0FE4D

Other ASIC Revision(s): Not Available

SPOT Sensor Value = 128

-- 5 Pt Font--

## 6.3 Print Quality Report

Standard print quality report available from the customer UI.

## 6.4 PrintMech button tap

Advanced testing for manufacturing purposes.

## 6.5 Counter report

Shows the full list of counters.

### SERVICE COUNTERS REPORT PAGE

=== Media Section ===

Loaded Rolls:  
- 8.5 Inches wide: 0      - 11 Inches wide: 0      - 18 Inches wide: 0  
- 24 Inches wide: 0      - 36 Inches wide: 0      - Other widths: 0  
Overall: 0

Measured Skew Values on Roll Load By Skew range (Units in mm/m):  
[.;-18]: 0      [-18;-14]: 0      [-14;-10]: 0      [-10;-6]: 0      [-6;-2]: 0  
[-2;2]: 0      [2;6]: 0      [6;10]: 0      [10;14]: 0      [14;18]: 0  
[18;.): 0

Hand-Fed Sheets: 0

LTray Pages:  
- Letter: 0      - Legal: 0      - Ledger: 0  
- A4: 1      - A3: 0      - Other Sizes: 0  
Overall: 1

LTray Pick Retries: 0

=== Jams & Crashes Section(In progress) ===

Carriage Stalls: 0      Jams: 1

=== Consumables Section ===

Replaced PHAs: 9  
Replaced C Cartridges: 1      Replaced M Cartridges: 1  
Replaced Y Cartridges: 1      Replaced K Cartridges: 1

=== Servicing Section ===

Capping Operations: 11      Wiping Cycles: 21  
Scrapping Cycles: 0      Priming Cycles: 28

=== Scan Axis Section ===

Scan Axis Covered Distance (inches): 6069  
Scan Axis Cycles: 135

Cutter Cycles:  
- 18 in wide: 0      - 24 in wide: 0  
- 36 in wide: 0      - Other widths: 0  
Overall: 0

=== Print Section ===

Jobs sent: 1

Printed area on roll (square inches):  
- Plain Paper Media Type:  
  Best Quality: 0      Normal Quality: 0      Fast Quality: 0  
  
- Other Media Types:  
  Best Quality: 0      Normal Quality: 0      Fast Quality: 0

## 6.6 Error history

Prints the error log.

-----  
 SERVICE AND DIAGNOSTICS REPORT  
 -----

Number of errors logged: 50 (max 50)

Sequence Id	Severity	Time Stamp	Occurrences	Error code
10	ADVISORY	Fri, 12 Jun 2015 15:36:28 GMT	1	0000-0000
11	ADVISORY	Fri, 12 Jun 2015 15:36:28 GMT	1	0000-0000
12	ADVISORY	Fri, 12 Jun 2015 15:36:29 GMT	1	0000-0000
13	ADVISORY	Fri, 12 Jun 2015 15:36:30 GMT	1	0000-0000
14	ADVISORY	Fri, 12 Jun 2015 15:36:30 GMT	1	0000-0000
15	ADVISORY	Fri, 12 Jun 2015 15:36:30 GMT	1	0000-0000
16	ADVISORY	Fri, 12 Jun 2015 15:36:31 GMT	1	0000-0000
17	ADVISORY	Fri, 12 Jun 2015 15:36:32 GMT	4	0000-0000
21	ADVISORY	Fri, 12 Jun 2015 15:36:33 GMT	2	0000-0000
23	ADVISORY	Fri, 12 Jun 2015 16:44:27 GMT	1	0000-0000
24	ADVISORY	Fri, 12 Jun 2015 16:44:28 GMT	1	0000-0000
...				
62	ADVISORY	Fri, 12 Jun 2015 16:45:56 GMT	1	0000-0000
63	ADVISORY	Fri, 12 Jun 2015 16:45:57 GMT	1	0000-0000

Internal Code	Behavior	Error Code	Description
0x00000001	IGNORE	0000-0001	For development purposes only. Test error ignored
0x00000002	LOG_ONLY	0000-0002	For development purposes only. Test error logging
0x00000003	WARNING	0000-0003	For development purposes only. Test warning message
0x00000004	UNRECOVERABLE	0000-0004	For development purposes only. Test unrecoverable error

## 6.7 PMK

Prints the PMK status report.

```
#-----#
|           Preventive Maintenance Kit Status Report           |
#-----#
```

PMK 1: Carriage - status: Not required

\* Carriage travelled distance in ~50km units

- CURRENT VALUE: 0
- Warning limit: 33
- Reset value: 0
- dsid: 76452

\* Carriage cycles

- CURRENT VALUE: 155
- Warning limit: 4000000
- Reset value: 0
- dsid: 71832

```
|-----|
```

PMK 2: Service Station - status: Not required

\* SVS & Left spittoon level gauge (warning at 95%, critical at 100%)

- CURRENT VALUE: 0
- Warning limit: 2
- Critical limit: 3

\* SVS level gauge (%)

- CURRENT VALUE: 0

\* Auxiliary spittoon level gauge (%)

- CURRENT VALUE: 0

\* SVS tolerance length flag

- CURRENT VALUE: 0
- Warning limit: 1
- Reset value: 0
- dsid: 77169

```
|-----|
```

PMK 3: Cutter - status: Not required

\* Cutter #cuts

- CURRENT VALUE: 0
- Warning limit: 28000
- Reset value: 0
- dsid: 76450

```
|-----|
```

## 6.8 Agent-assisted image

Prints IQ troubleshooting page. It is recommended to use Plain paper (>85gsm).

## AGENT-ASSISTED IMAGE TEST

### Product and Revision Information

1. Serial Number: CN22M0M04C

2. Firmware Version: AXP1CN1226FR

### Ink Delivery System Information

3. Ink Supply:

Magenta

Cyan

Yellow

Black

4. SHAID Status:

0

0

0

0

5. End of Warranty Date (Y-M-D):

2014/02/26

2013/12/17

2013/12/17

2014/01/01

6. Warranty Status:

OK

OK

OK

OK

### Print Head Information

7. Total Drop Count (ml):

Magenta: 0.872

Cyan: 0.864

Yellow: 0.939

Black: 1.080

8. PHA Install Date:

2012/03/28

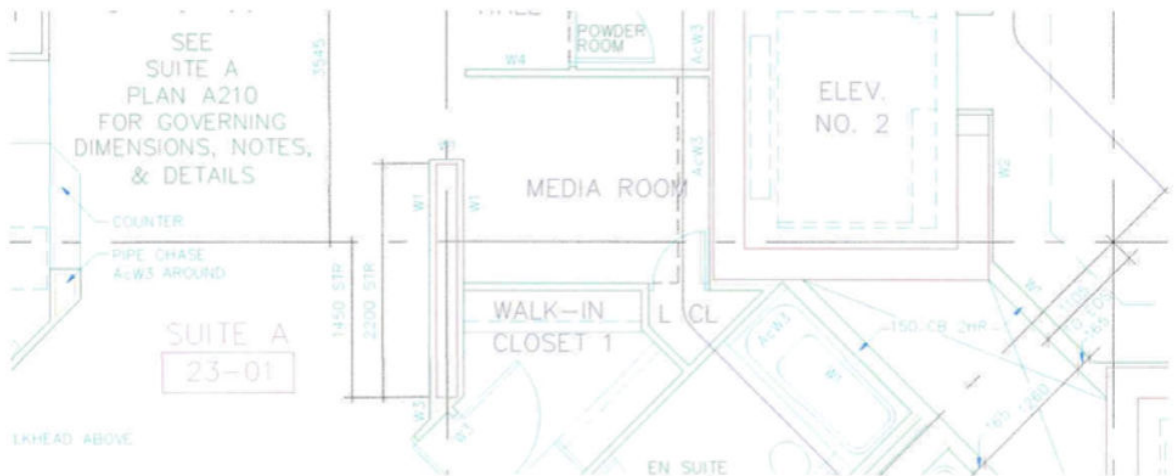

## Scan Diagnostics

### 7.1 Scanner sensors

Sensors tested:

- OPT left and right
- TOP

- Load
- Latches left and right
- Lid

### Procedure

1. From the **Scanner Diagnostics** menu, select **7.1 Scanner Sensor** and then **OK**.
2. The following screen is displayed:



3. Press **OK**, then the following screen is shown. Push the latches, **do not lift** the scanner lid and press **OK**.

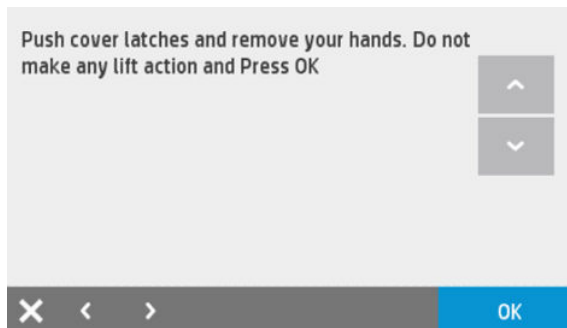



4. After pressing OK, the following screen is shown.

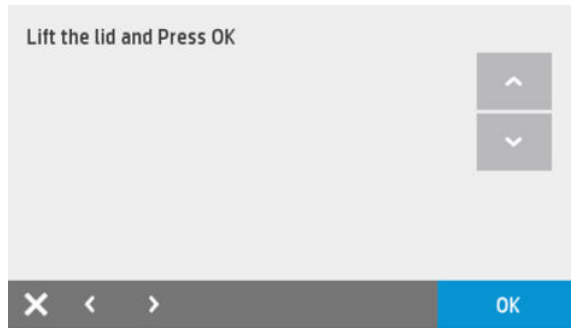

5. Now lift the lid and press **OK**.

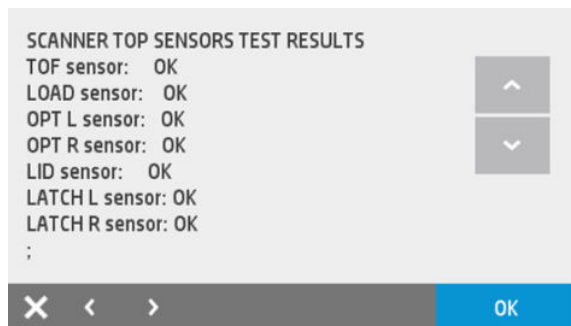

6. Press **OK** then the following screen is shown.

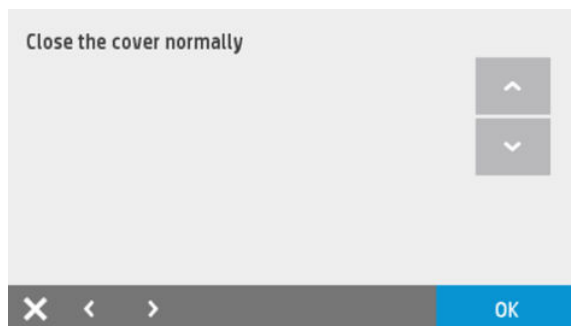

7. Close the lid normally.

The test is able to detect if the sensor changes the state. It can be sensor, cable, or Scanner Bundle Board.

## 7.2 Scanner media drive

Elements tested:

- Bottom of Form (BOF) sensor
- OPT Wheel encoder and index
- Motor, motor encoder

### Procedure

1. From the **Scanner Diagnostics** menu, select **7.2 Scanner Media Drive** and then **OK**.



2. The following screen is displayed:



3. With the lid closed, feed A4/letter paper into the scanner:
  - a. Motor operation judged by PWM supply and reads encoder counts:
    - ▲ Fail: motor or encoder or MPCA (motor power is in MPCA) or Scanner Bundle Board (SBB) (encoder is in SBB).
  - b. OPT wheel is judged by: Motor encoder OK and OPT wheel encoder not OK, then it is sure there is paper because the load optical sensor is active:
    - ▲ Fail: OPT wheel encoder and index or SBB (Index sensor is independent of OPT encoder).
  - c. BOF: detect state change:
    - i. Fail: BOF or SBB. monitoring the counts between the Top of Form (TOF) trigger and BOF trigger.
    - ii. If there is a media jam, this would trigger a fail and is not true.
    - iii. Message should be: "the test has failed for the BOF, check the cause is not a media jam. If you want to verify, click OK to repeat".

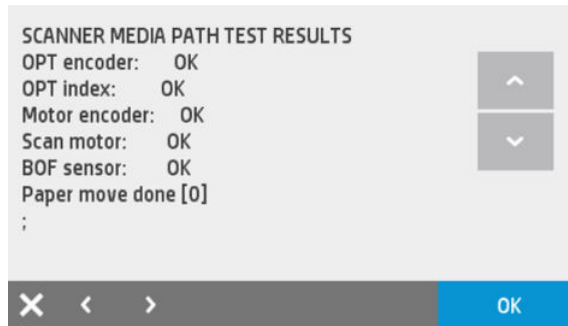

4. Finally, eject the media if not already done:

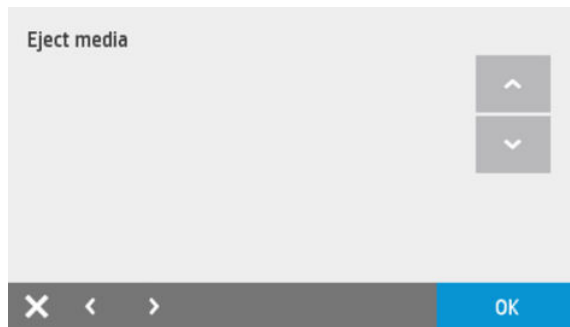

## Extended Support menu

Here you will find an explanation in detail only of those items not included or different in the Support Menu. These resets and utilities should be used only by HP service engineers. For a diagram of the menu tree, see [Support Menu and Extended Support Menu Tree on page 545](#).

### 2. Reset menu

#### 2.1 OOB reset

Resets the unit with manufacturing calibrations, except the tubes status.

#### 2.6 PMK1

Use this option to reset the counters after installing the Print Maintenance Kit 1 or if replacing the Carriage Assembly/Carriage Belt/Cutter/Encoder Strip.

#### 2.7 PMK2

Use this option to reset the counters after installing the Print Maintenance Kit 2 or if replacing the Service Station.

#### 2.8 Mark Tubes as empty

In the case of an ink tubes replacement, they must be marked as empty tubes. A new (empty) printhead and new ink supplies are required to ensure the tubes and printhead can be correctly filled with ink.

#### 2.9 Power-On button behaviour reset.

When doing a Main PCA replacement, it may happen that the new MPCA does not power off the unit (it restarts instead) when the power button is pressed to shut the unit down. This entry changes the power button behaviour so, when it is pressed, the unit will shut down. If the unit already has this behaviour, the reset does not change it.

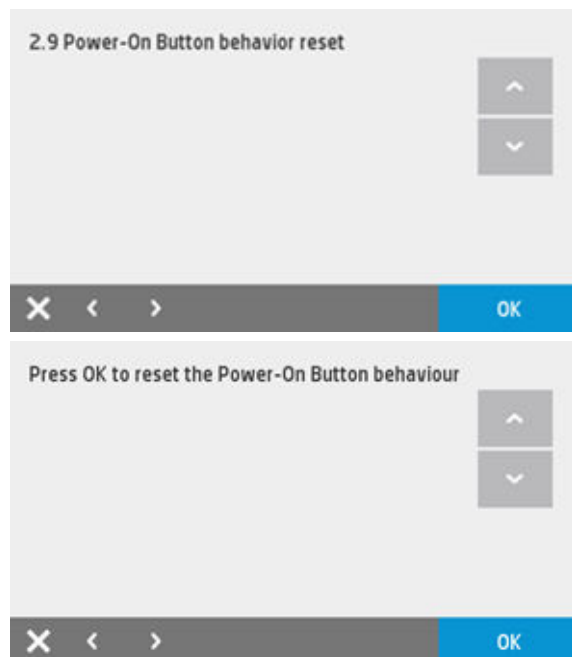

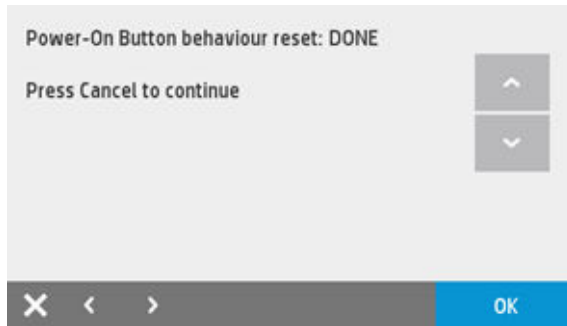

## 2.10 RTC Battery expired

Use this option to reset the RTC battery flag after replacing the RTC battery.

## 3. System Configuration

### 3.2 Set Wireless Region

This option can be used to change the Wireless region.

1. From the Extended Support Menu, select **3.2 Set Wireless Region** and then **OK**.
2. The following screen is displayed:

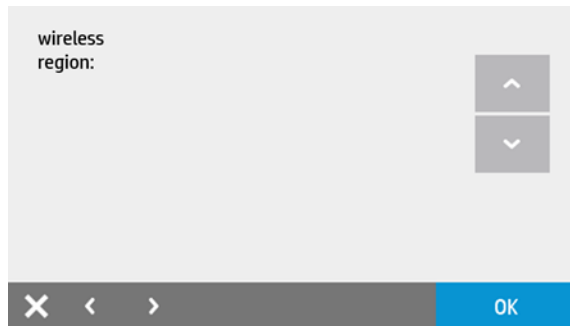

3. Press **OK**.
4. Use the left  and right  arrows to change the wireless region.

---

 **CAUTION:** Changing the wireless region has legal implications. If you change the region, be sure you are using the correct wireless region for the country in which the printer is installed.

---

The options available are the following:

- **World Safe:** It can be used worldwide, and is the default region in the printer. If you are not sure which region to use, please configure the printer with the World Safe region.
  - Settings: 2.4 Ghz; Maximum Power EIRP = 20 dBm; Channels = 1 to 11
- **World:** This region can be used worldwide **except** in the following countries: USA, Canada, and Taiwan.
  - Settings: 2.4 Ghz; Maximum Power EIRP = 20 dBm; Channels = 1 to 13
- **US:** This region can be used **only** in the USA, Canada, or Taiwan. Do not use this wireless region in any other country.

- Settings: 2.4 Ghz; Maximum Power EIRP = 30 dBm; Channels = 1 to 11

# 7. Scanner diagnostics (included only in Extended Support Menu)

## 7.3 Scanner runout calibration

Required when the OPT wheel of the scanner is replaced in the field.

1. From the **Scanner Diagnostics** menu, select **7.3 Scanner runout calibration** and then **OK**.
2. The following screen is displayed:

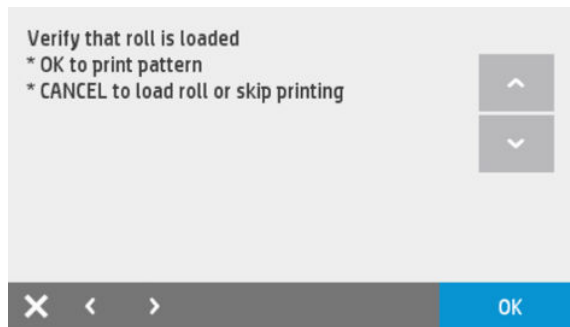

- a. If calibration plot is not available, it needs to be printed out:

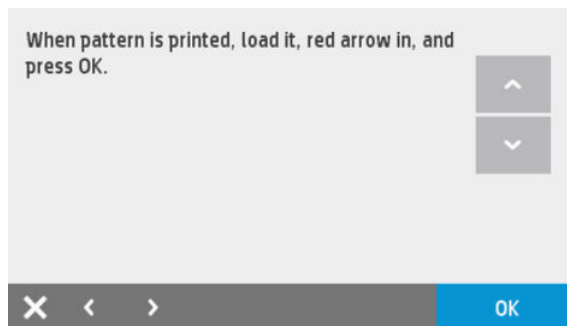

- b. Load the calibration plot that just printed out:

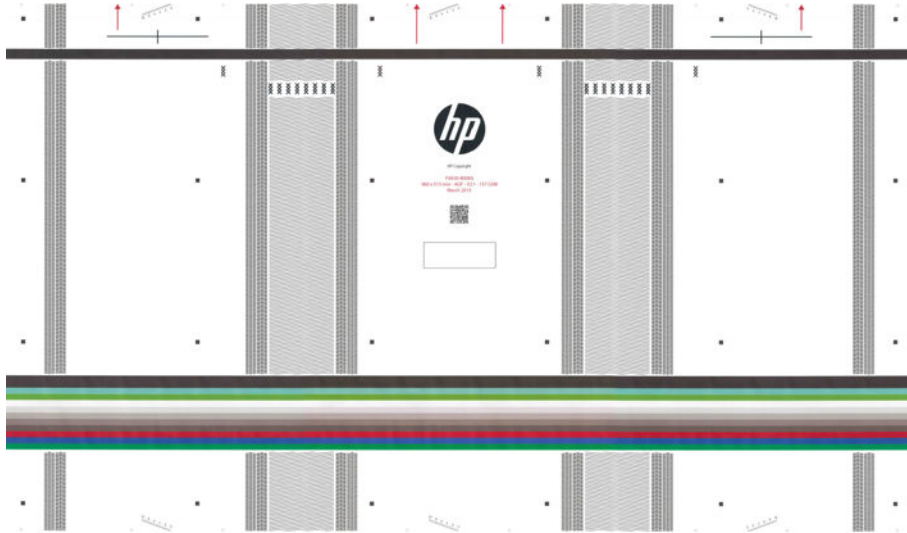

 **IMPORTANT:** The pattern for “Scanner run out calibration” and “Scanbar alignment&PRNU target compensation” calibration plots is the same but the printing direction is different. They may look the same but they are not compatible for performing the calibration.

3. After scanning the following message appears:



## 7.4 Promote PRNU to Pristine calibration

Needs to be run when the scanbars & calibrations surfaces are replaced or when the calibration surfaces are replaced. After new parts are installed, this should be conducted immediately after the first boot up.

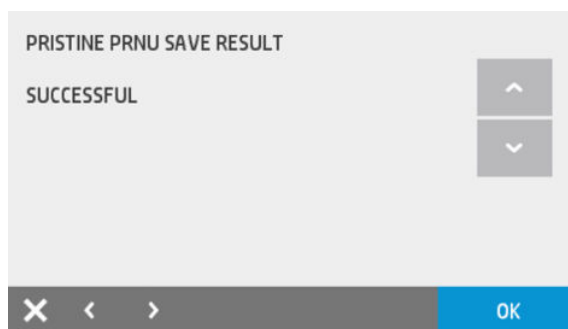

 **NOTE:** Only use this option if you have replaced the scanbars (all 3 scanbar need to be changed).



 **NOTE:** Pristine PRNU is the white balance calibration that is done in the factory in clean conditions, just after removing all protective films. Under such conditions, PRNU calibration is the best quality possible and is used for reference to detect dust in the scanner and component degradation.

---

## 7.5 Scanner save calibrations

This needs to be conducted when synchronization between the Main PCA and Scan Bundle Board is required. Possible scenarios are:

1. Scanbar replacement.
2. Calibration surfaces replacement.
3. Main PCA replacement.
4. Scan Bundle board replacement.

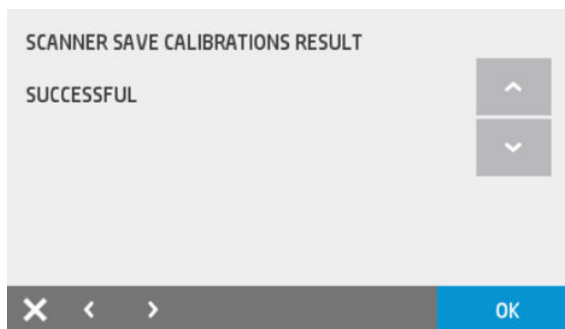

## 7.6 Scanner Analog Encoder calibration

Needs to be run when the scanner OPT wheel is replaced in the field. Run this operation on the first boot up after the OPT wheel is replaced.

# Diagnostic Plots & Calibrations

Samples of good plots are shown.

## Print IQ Diagnostic Plot

### Test Pattern 1

If the lines are not straight and connected, align the printheads.

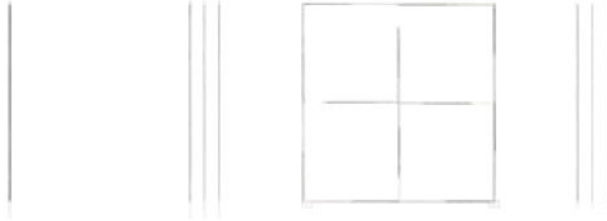

### Test Pattern 2

If the thin white lines are seen across any of the colored blocks, clean the printheads.

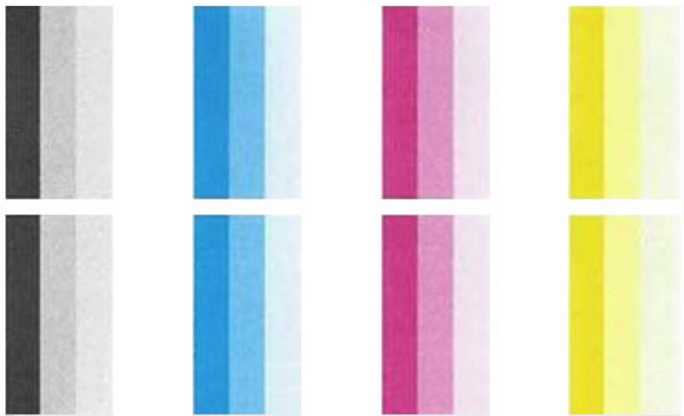

## Media Advance Calibration Plot



## Automatic Printhead Alignment Plot

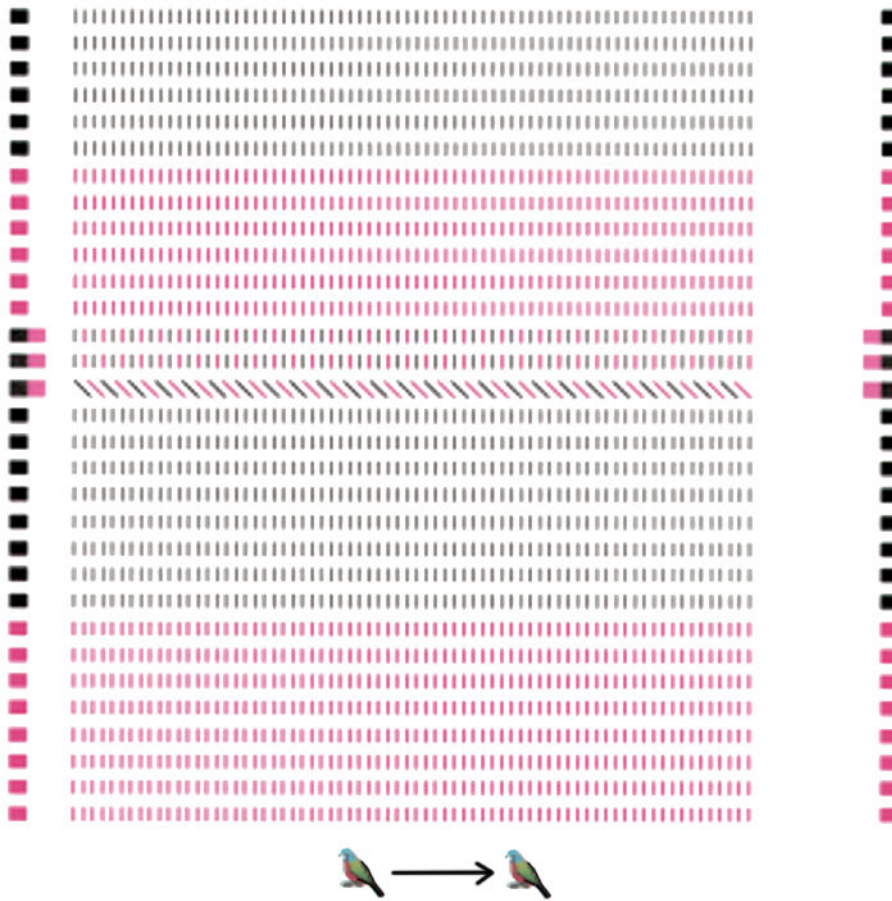

## Scan IQ Diagnostic Plot

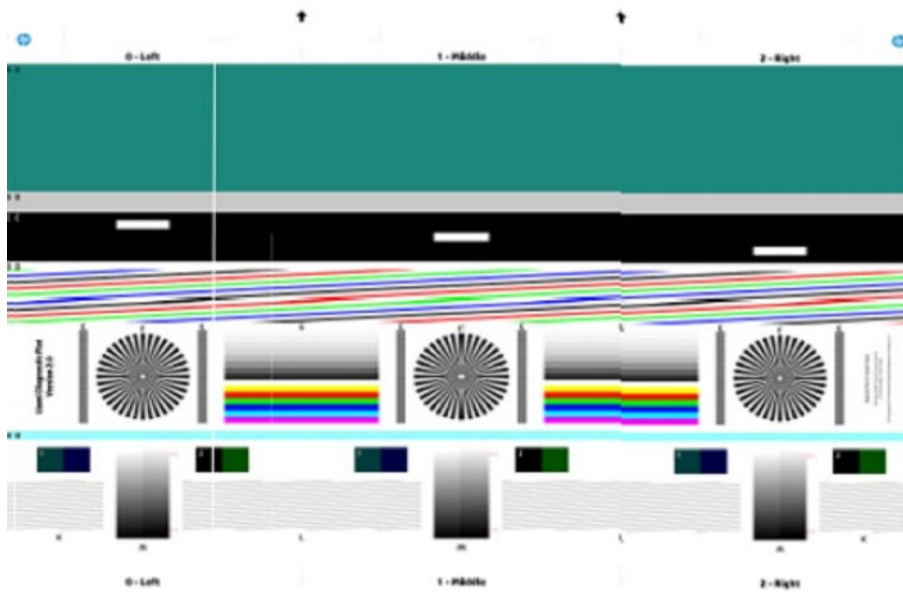

## Scan Calibration Plot

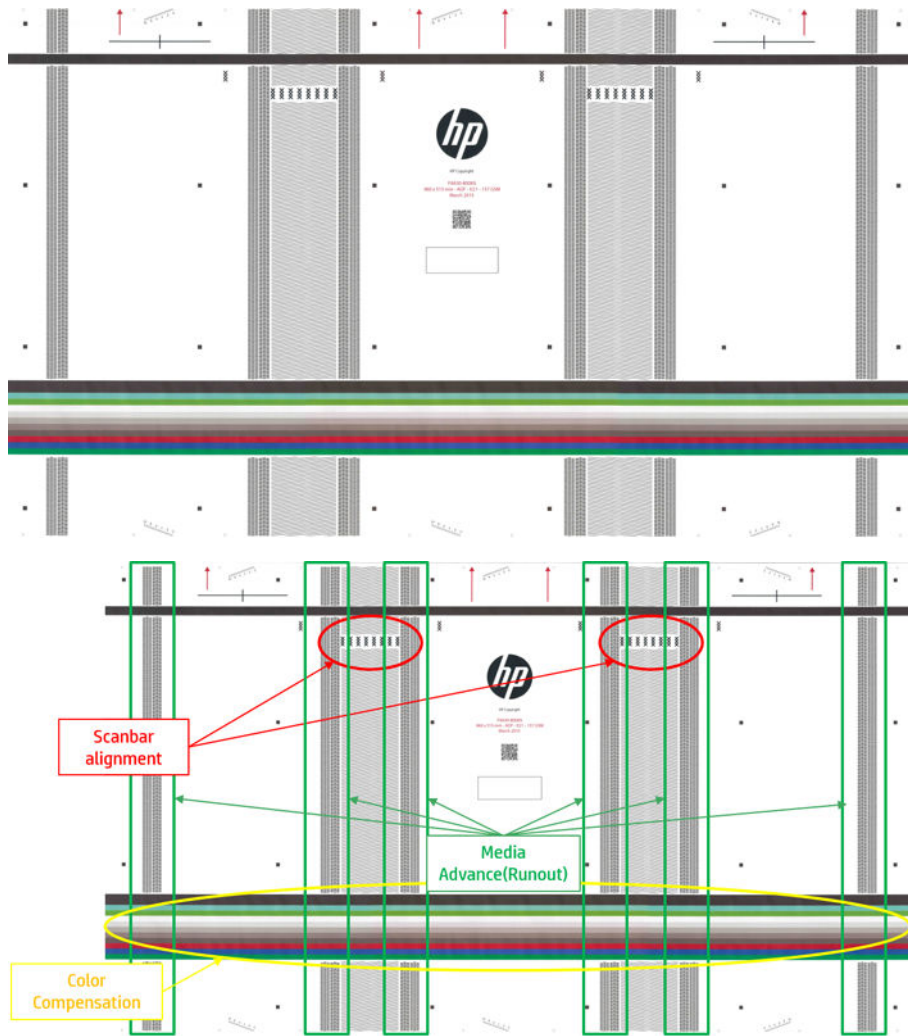

## Calibrations

	Calibration	User calibration?	Where to find it?	Need a plot?	Need media?
1	Printhead Alignment	Yes	Customer Menu	No	Yes
2	Paper Advance Calibration	Yes	Customer Menu	No	Yes
3	Manual Media Advance adjustment	Yes	Customer Menu	No	No
4	Scanbar Alignment & Color Uniformity	Yes	Customer Menu	yes, calibration plot	No
5	Scanner Run Out (Media Advance) Calibration	No	Extended Support Menu	yes, calibration plot	No

	Calibration	User calibration?	Where to find it?	Need a plot?	Need media?
6	Scanner Analog encoder Calibration	No	Extended Support Menu	Any media sheet	Yes
7	Scanner PRNU calibration (White Balance)	Yes	Automatic at every start up or after a set number of scans	No	No
8	Scanner Promote PRNU to Pristine PRNU	No	Extended Support Menu	No	No

For reference, below is a table with the calibrations that need to be run when a scanner component is replaced:

CALIBRATIONS REQUIRED vs PARTS REPLACED	Scan Bundle Board	OPT Wheel	Scan Bars	Calibrations Surfaces	Scan Motor	Main PCA Board
Promote to Pristine PRNU	No	No	Yes	Yes	No	No
Analog encoder OPT wheel	Yes	Yes	No	No	No	No
Scanner Media Advance (Runout OPT wheel)	No	Yes	No	No	No	No
Scanbar alignment&Color Uniformity (PRNU Target Comp.)	No	Yes	Yes	Yes	No	Yes
Extended Support Menu Calibrations						
Support Menu Calibrations						

**NOTE:** In case of having to replace **both** Scan Bundle Board and OPT wheel:

- 1) Replace Scan Bundle Board
- 2) Replace OPT wheel
- 3) Run all calibrations (Analog encoder, Scanner Media Advance, Scanbar Alignment&color uniformity)

Factory calibrations are stored in the Scanner Bundle Board:

1. PRNU (white balance) pristine.
2. Scanner Media Advance calibration.
3. Analog encoder calibration (OPT wheel encoder).
4. Color uniformity and Scanbar alignment.

All Scanner Bundle Board PCA NVM data is replicated in the Main PCA NVM.

The PRNU (white balance; automatic at every start up) is only stored in the MPCA RAM since it is run at every start up. When the power is down, it is lost.

If every user calibration needed to be Synchronized with the Scanner Bundle Board, all NVM calibrations would have to synced too, which would mean 2MB of information in a SPI bus. There is a high risk of the unit freezing, and all NVMs becoming corrupted. As a result, the calibrations that are “easy to run” will not be copied to the Scanner Bundle PCA NVM on normal use basis. This calibration is: Scanbar alignment & color uniformity, and is only in the MPCA.

If the MPCA is replaced, the new one is empty by default and the printer will run Scanner Bundle PCA calibrations. Since the Scanbar alignment & color uniformity may be an old version in the Scanner Bundle PCA (from factory), Scanbar alignment & color uniformity is run after MPCA replacement.

When replacing the Scan Bundle Board or the MPCA, there is no auto sync, so access needs be via the front panel option (Extended Support Menu). Failure to do so prevents the printer from using any factory calibration (impacting IQ).

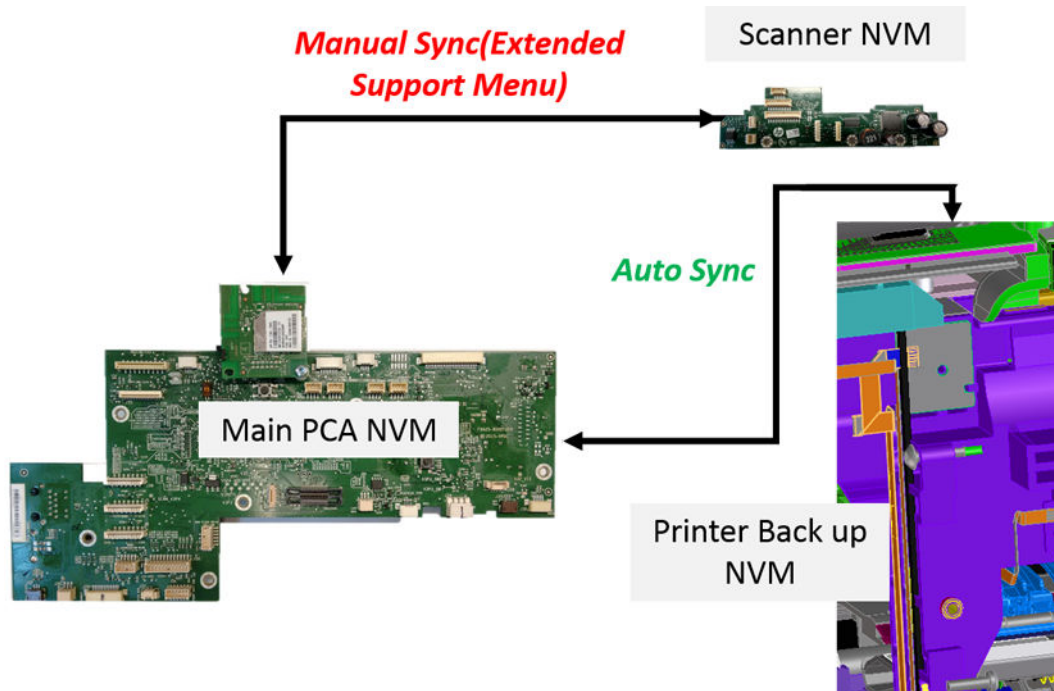

---

# 4 Parts and diagrams

- [Introduction](#)
- [Printer stand](#)
- [Stand HW SV kit](#)
- [Covers HP DesignJet T730 Printer](#)
- [Covers HP DesignJet T830 MFP](#)
- [Roll covers](#)
- [Right-hand assemblies](#)
- [Left-hand assemblies](#)
- [Carriage assembly](#)
- [Paper path \(front\)](#)
- [Paper path \(rear\)](#)
- [Spindle](#)
- [Sensor Kit](#)
- [Cable Kit](#)
- [Ink tubes \(RIDS\) and Ink Supply Station \(ISS\)](#)
- [Scanner Lid](#)
- [Scanner Bottom Mech](#)
- [Scanner Bottom-EE](#)
- [Scanner Back](#)
- [Miscellaneous parts](#)

## Introduction

- The list of parts in this chapter include the notation CSR A or CSR B for parts that can be replaced by the customer. All other parts must be replaced by an engineer. See [Customer Self Repair parts on page 256](#).
- For information on part replacement visit HP Customer Self Repair Services Media Library - Media Selection, ("**Printers and Multifunction > HP DesignJet Printers**"), at: <http://h20464.www2.hp.com/index.html>
- Part Numbers of SV kits are subject to change. Please double check in the HP Part Surfer for the latest version or elevate to the next support level for advice.
- For information on the preventive maintenance kits, see [Preventive maintenance kits on page 537](#).
- Unless otherwise indicated, service parts are compatible with all SKUs. If there is any limitation, it is indicated in the tables below as follows:
  - SFP: compatible with the HP DesignJet T730 Printer
  - MFP: compatible with the HP DesignJet T830 MFP

For further info:



# Printer stand

	HP part number	Part description	Removal and installation reference	Comments
1	F9A30-67057	Stand Right Leg Assembly		CSR A
2	F9A30-67059	Stand HW kit		CSR A: Includes all screws, tools and 4 wheels to repair and mount the stand
3	F9A30-67058	Stand Basket SV kit		CSR A
4	F9A30-67056	Stand Left Leg Assembly		CSR A

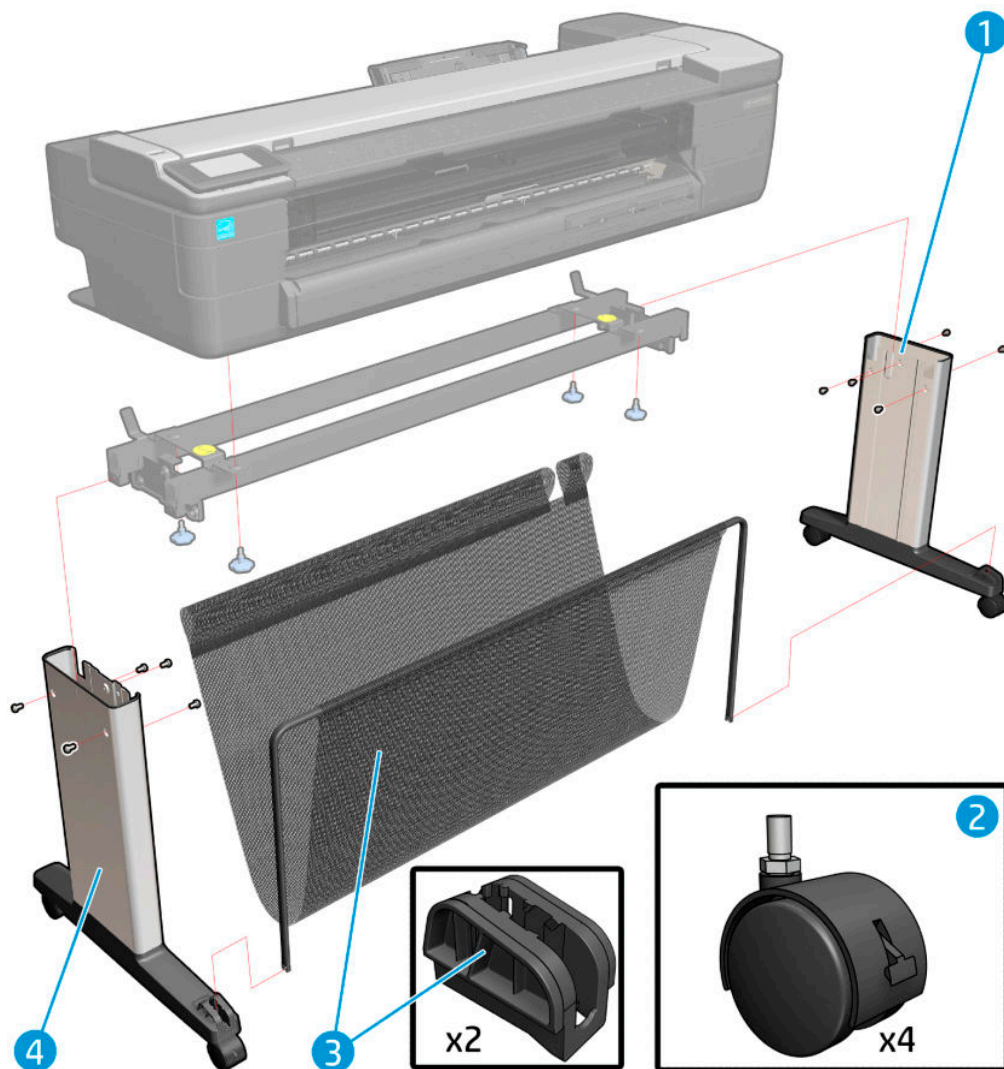

## Stand HW SV kit

1. Handle M5x14mm. Qty: 4



2. Tool



3. Screws Qty: 10

4. Triangle positioner. Qty: 2



5. Wheels. Qty: 4



# Covers HP DesignJet T730 Printer

	HP part number	Part description	Removal and installation reference	Comments
1	F9A30-67014	Ink door cover SV kit	<a href="#">Ink Door flir on page 584</a>	CSR A
2	F9A29-67004	Right cover SFP SV kit		
3	F9A30-67010	Assembly PH Door SV kit		CSR A
4	CQ894-67001	36 Front Cover SV	<a href="#">Front Cover on page 261</a>	CSR A
5	F9A29-67006	Central covers SFP SV	<a href="#">Central Cover on page 284</a>	
6	F9A30-67006	Assembly Cutter Door SV kit	<a href="#">Cutter Door F9A30-67006 on page 378</a>	CSR B: Need a flat screwdriver
7	F9A29-67005	Left cover SFP SV kit		
8	CQ893-67002	36 Back cover SV	<a href="#">Back Cover on page 275</a>	
9	F9A29-67007	Top window SFP SV kit	<a href="#">Top window SFP F9A29-67007 on page 258</a> also known as Central Window	CSR A

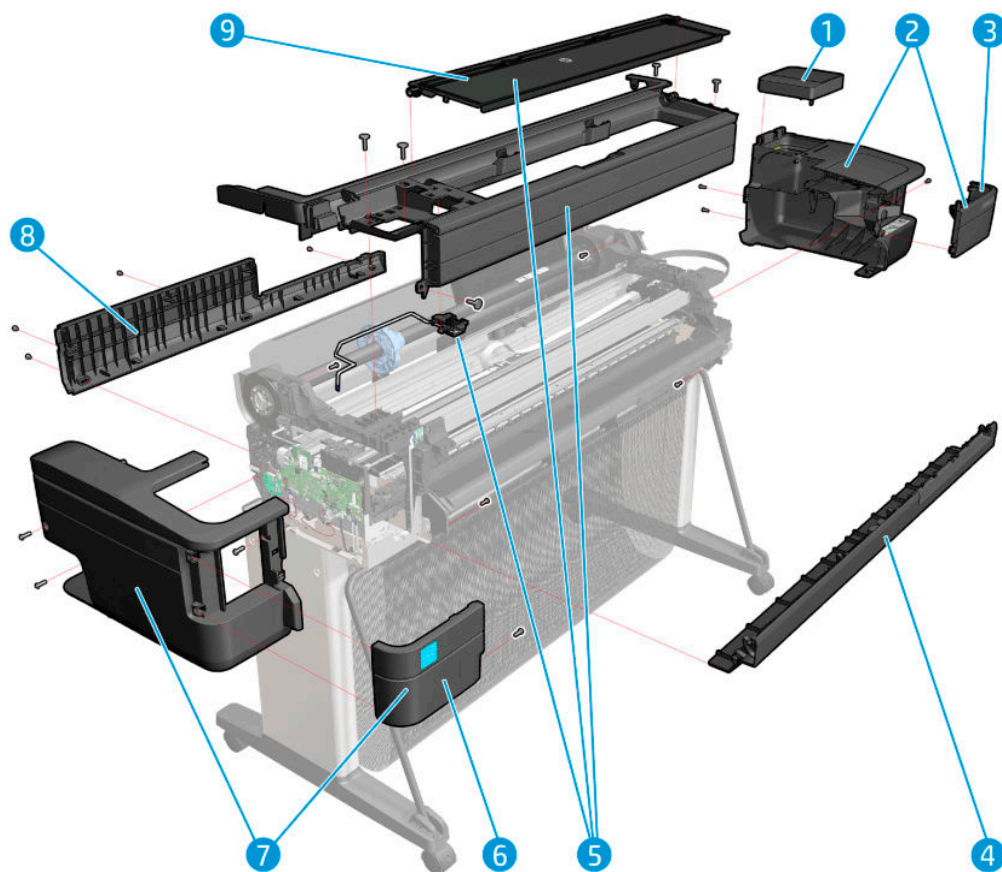

## Covers HP DesignJet T830 MFP

	HP part number	Part description	Removal and installation reference	Comments
1	F9A30-67014	Ink door cover SV kit		CSR A see <a href="#">Ink Door flier on page 584</a>
2	F9A30-67011	Right cover SFP SV kit	<a href="#">Right Cover MFP SV Kit F9A30-67011 on page 264</a>	
3	F9A30-67010	Assembly PH Door SV kit		CSR A
4	F9A30-67035	Refeed preventers SV kit	<a href="#">Refeed Preventer on page 504</a>	CSR A
5	CQ894-67001	36 Front Cover SV	<a href="#">Front Cover on page 261</a>	CSR A see <a href="#">Front Cover flier on page 569</a>
6	F9A30-67013	Front frame window MFP SV kit		
7	F9A30-67006	Assembly Cutter Door SV kit	<a href="#">Cutter Door F9A30-67006 on page 378</a>	CSR B: Need a flat screwdriver
8	F9A30-67012	Left cover SFP SV kit	<a href="#">Left Cover MFP SV Kit F9A30-67012 on page 268</a>	
9	CQ893-67002	36 Back cover SV	<a href="#">Back Cover on page 275</a>	
10	F9A30-67016	Top cover button latch MFP SV	<a href="#">Top window SFP F9A29-67007 on page 258</a>	Latches for scanner lid
11	F9A30-67015	Central covers SFP SV	<a href="#">Central Cover on page 284</a>	Scanner top cover. The kit also contains F9A30-60224 Central top cover (behind the scanner)

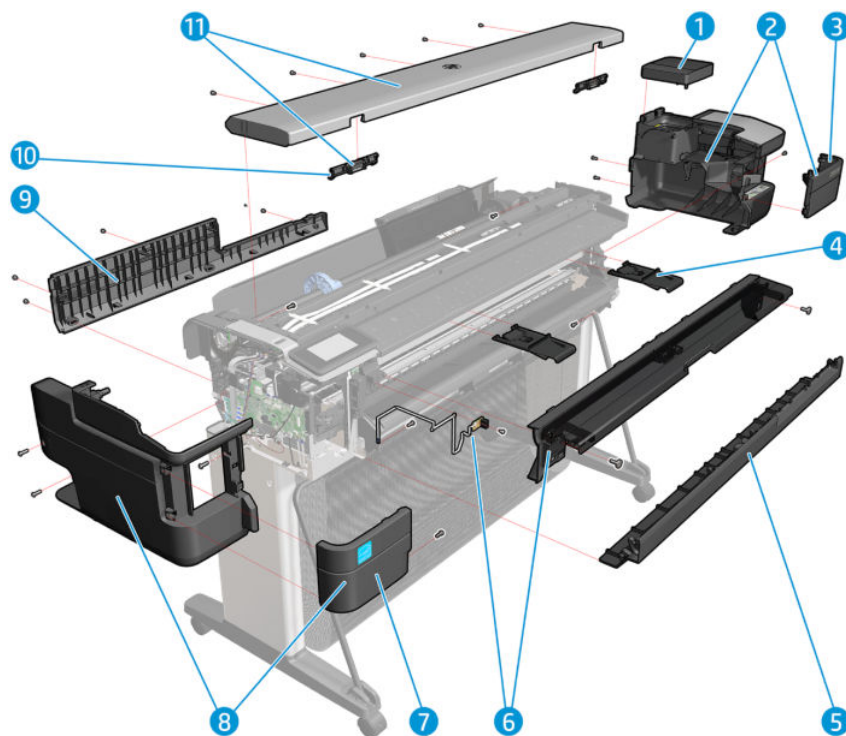

## Roll covers

	HP part number	Part description	Removal and installation reference	Comments
1	CQ893-67003	Roll Cover (36)	<a href="#">Roll Cover on page 272</a>	
2	F9A30-67050	Candela Left Roll Support SV	<a href="#">Left Roll Support on page 292</a>	
3	F9A30-67051	Candela Right Roll Support SV	<a href="#">Right Roll Support on page 297</a>	

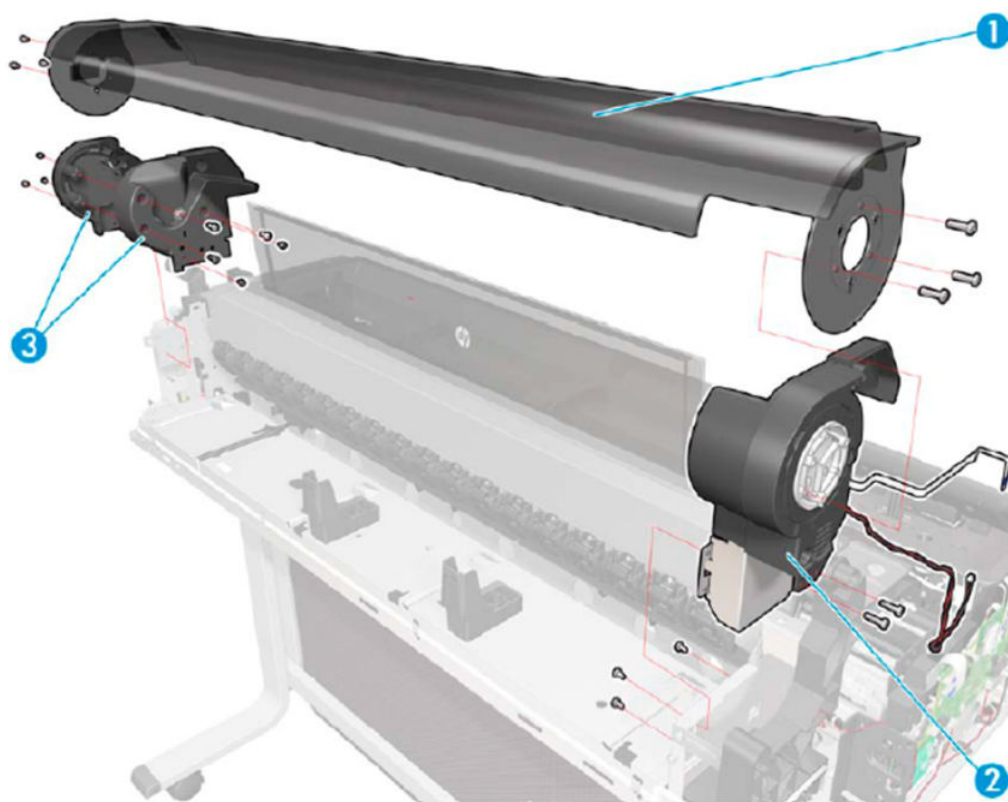

## Right-hand assemblies

	HP part number	Part description	Removal and installation reference	Comments
1	F9A30-67048	Prime pump SV kit	<a href="#">Prime Pump on page 340</a>	
2	F9A30-67004	Print Bundle PCA SV	<a href="#">Bundle Board on page 406</a>	SV kit includes FFC connecting Printer Bundle Board with Main PCA.
3	F9A30-67052	Service Station Assembly (see real image below)	<a href="#">Service Station on page 334</a>	Includes the Service Station motor, encoder, spittoons, wipers, extra absorber pad (in case of need), extra left spittoon (in case of need), and gloves. The Left Spittoon is available also in a separate kit (see <a href="#">Left-hand assemblies on page 236</a> ).

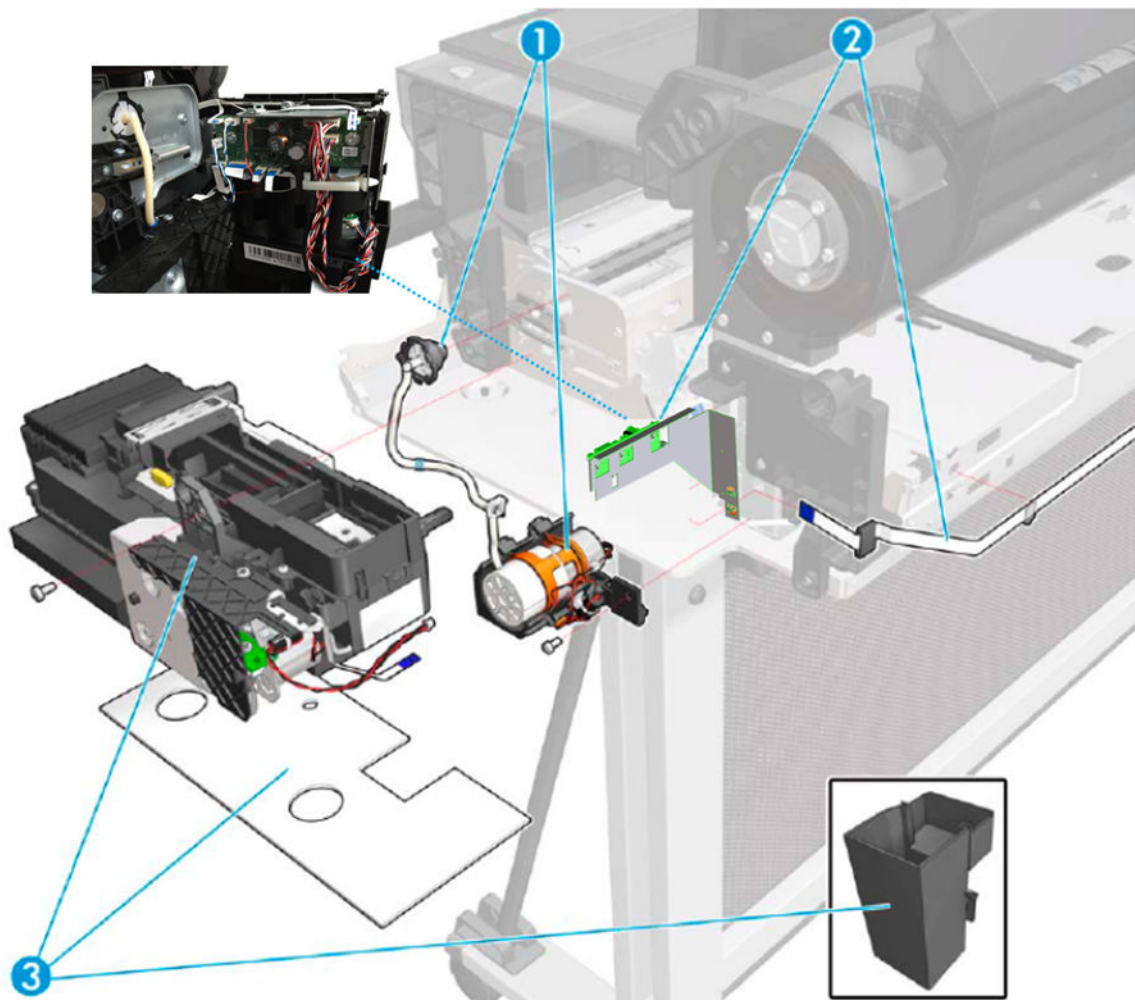

**Service Station assembly F9A30-67052.**

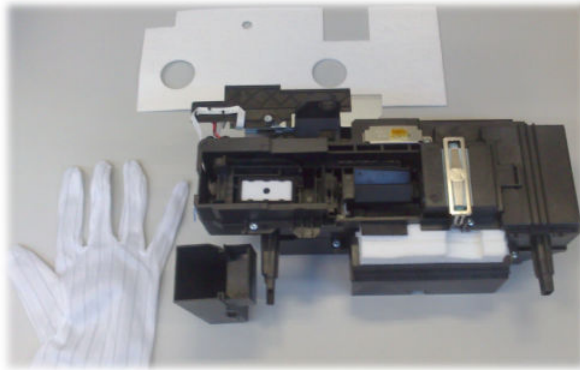

## Left-hand assemblies

	HP part number	Part description	Removal and installation reference	Comments
1	F9A29-67008	Control Panel and support SFP (T730)	<a href="#">Front Panel SFP F9A29-67008 on page 278</a>	Includes plastic support with power button and cables
2	F9A30-67047	NVM Backup PCA SV kit		
3	CQ890-67044	Left side spittoon SV	<a href="#">Left Spittoon on page 420</a>	Includes gloves.
4	CQ890-67033	Encoder disk SV	<a href="#">Encoder Disk on page 323</a>	SV kit includes the brush. For sensor parts, see <a href="#">Sensor Kit on page 242</a>
5	F9A30-67001	MAIN PCA SV	<a href="#">Main PCA on page 311</a>	
6	CQ890-67089	5V Power Supply SV	<a href="#">Power Supply on page 308</a>	
7	F9A30-67043	Control Panel and left trim MF (T830)	<a href="#">Front Panel SFP F9A29-67008 on page 278</a>	Includes plastic support with power button and cables

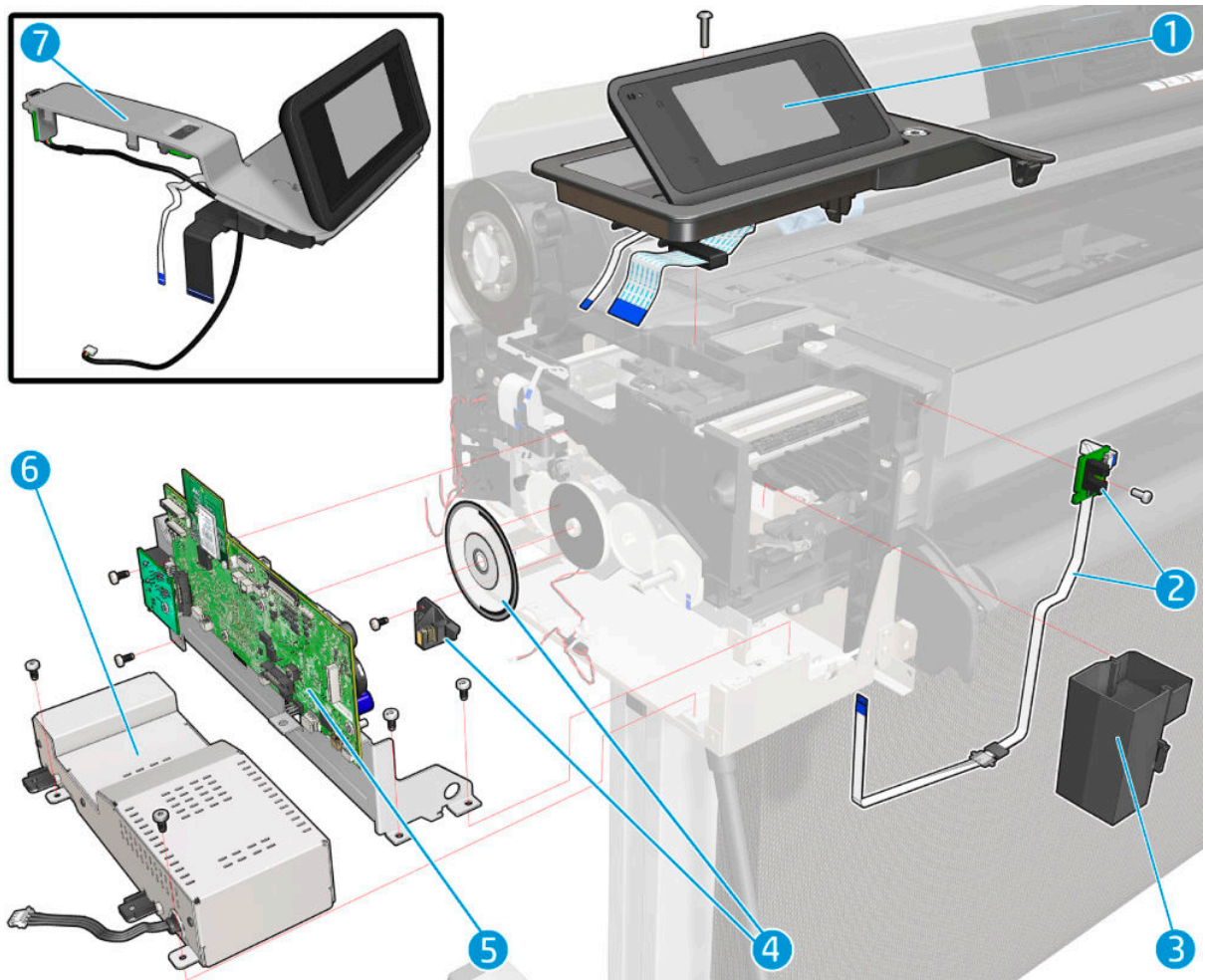



## Encoder Disk SV kit, CQ890-67033



## Carriage assembly

	HP part number	Part description	Removal and installation reference	Comments
1	F9A30-67061	Carriage Assembly	<a href="#">Carriage and Belt on page 344</a>	Includes carriage base, carriage PCA and cover, Carriage Line Sensor, extra Encoder Strip, instruction flier, and gloves
2	CQ890-67001	Carriage Line Sensor (ZIM Sensor)	<a href="#">Carriage Line Sensor on page 402</a>	
3	CQ893-67016	Belt (36)	<a href="#">Carriage Belt on page 351</a>	
4	CQ893-67029	36 Encoder strip SV	<a href="#">Encoder Strip on page 300</a>	Includes gloves
5	CQ890-67091	Cutter Y margin new Extract Li		It includes cutter, extraction lid, carriage bridge and screwdriver. There is also a Cutter CSR SV kit: "CQ890-67090 Cutter CSR SV kit"
6	F9A30-67063	Carriage Motor	<a href="#">Carriage Motor on page 374</a>	
7	CQ893-67001	36 Trailing cable SV	<a href="#">Trailing Cable on page 326</a>	

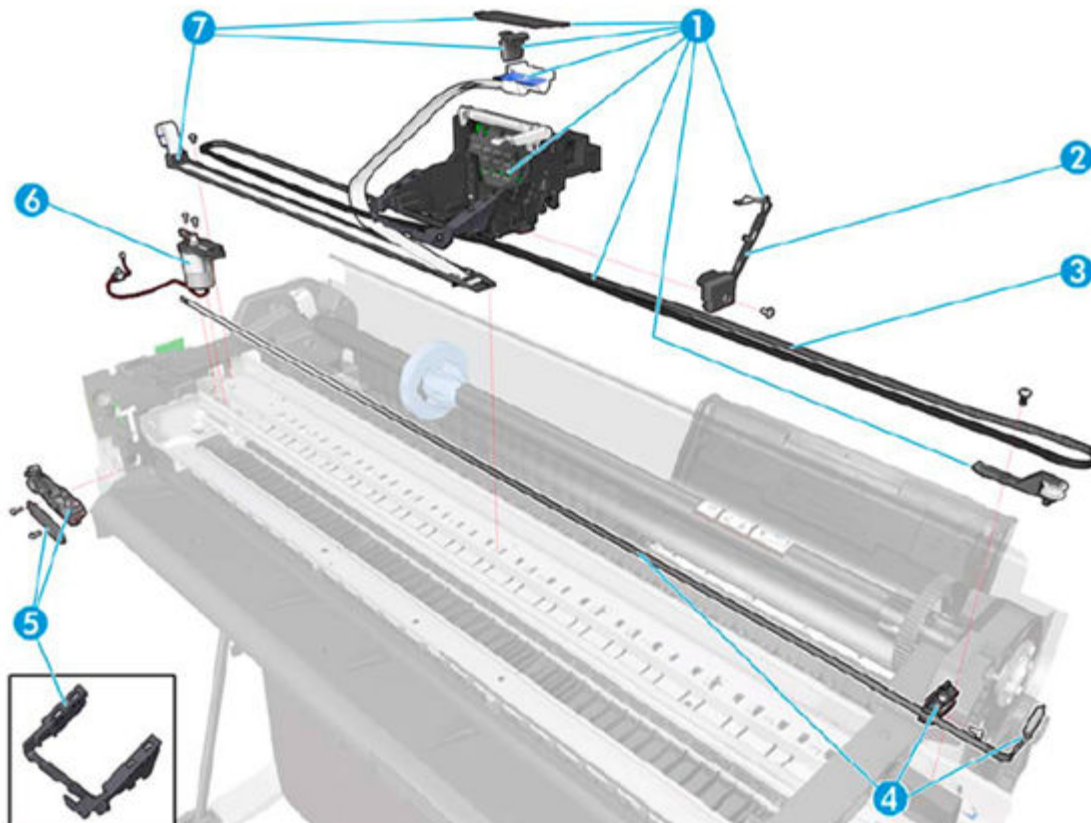

## Paper path (front)

	HP part number	Part description	Removal and installation reference	Comments
1	CQ893-67022	36 Starwheel assy SV Rep	<a href="#">Starwheel Assembly on page 356</a>	Includes the Output Shaft and instruction flier
2	F9A30-67054	Right Gear Train SV	<a href="#">Right Gear Train Module on page 353</a>	
3	CQ893-67018	Output Tray Sensor SV		CSR B (has no cable included); see <a href="#">Out-Of-Paper Sensor flier on page 572</a>
4	CQ890-67019	Pro Extension/Output Tray	<a href="#">Output Tray on page 365</a>	CSR A
5	CQ893-67027	Output Platen New Lid 36	<a href="#">Output Platen on page 370</a>	The cutter rail is not a service part

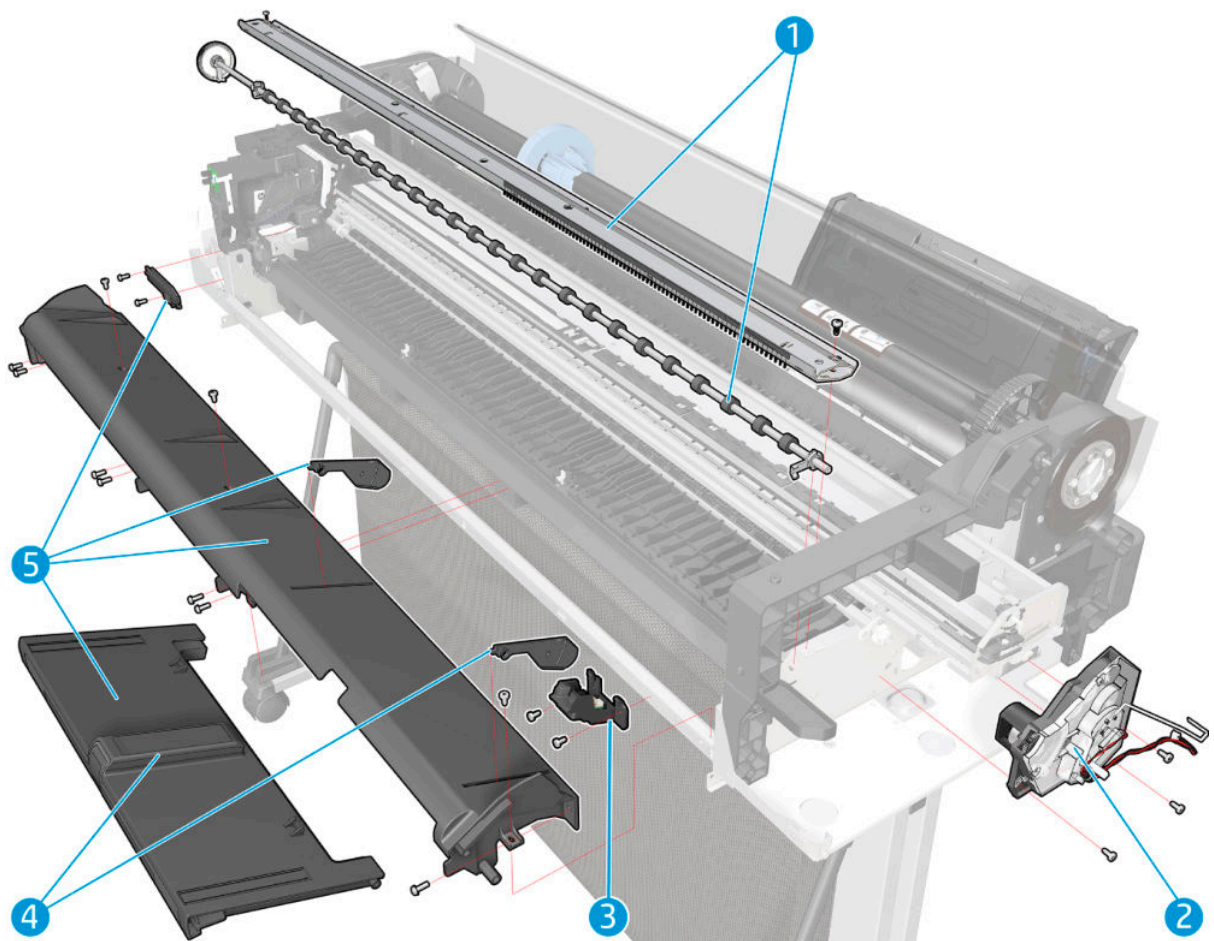

## Paper path (rear)

	HP part number	Part description	Removal and installation reference	Comments
1	F9A30-67009	Assembly Multi-sheet tray SV kit	<a href="#">Multi-Sheet Tray Sensor Assembly on page 385</a>	
2	F9A30-67049	Paper Motor SV kit	<a href="#">Paper Motor on page 317</a>	
3	CQ890-67060	Pinches Assembly SV	<a href="#">Pinchwheels on page 414</a>	Includes 3 pinchwheels, a tool to remove and mount them, and an instruction flier
4	CQ890-67007	Accessory Tray SV	<a href="#">Multi-Sheet Tray Assembly on page 367</a>	CSR A
5	CQ890-67047	Extension in the accessory		CSR A; see <a href="#">Multi-Sheet Tray Extension flier on page 570</a>
6	F9A30-67053	OOPS Sensor flag w/tap	<a href="#">Out-Of-Paper Sensor on page 388</a>	CSR B; see <a href="#">Out-Of-Paper Sensor flier on page 572</a>

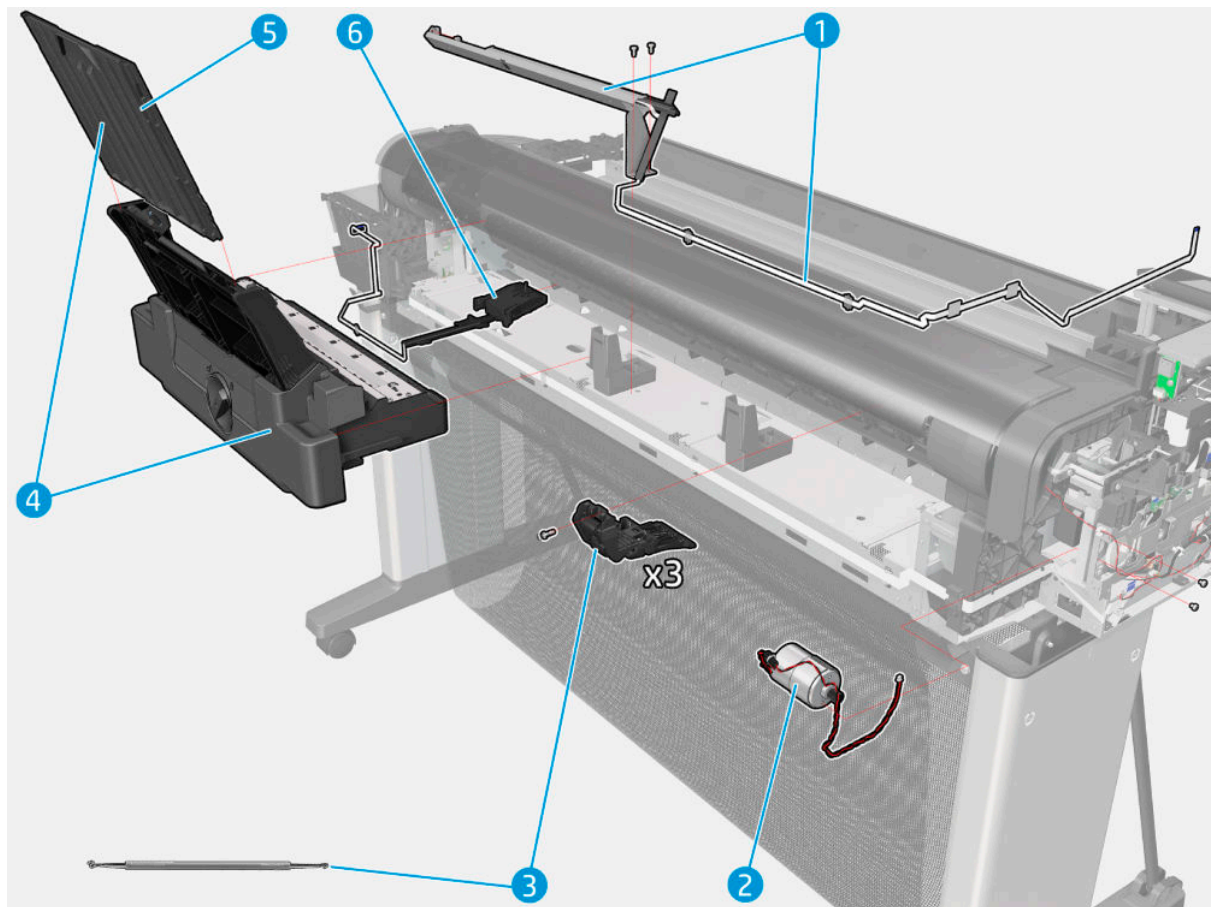

# Spindle

	HP part number	Part description	Removal and installation reference	Comments
1	CQ893-67008	36 Spindle module SV		CSR A. It contains the spindle (with black hub) and the blue hub
2	CQ893-67009	Spindle hubs SV		CSR A. It contains the blue hub and the black hub

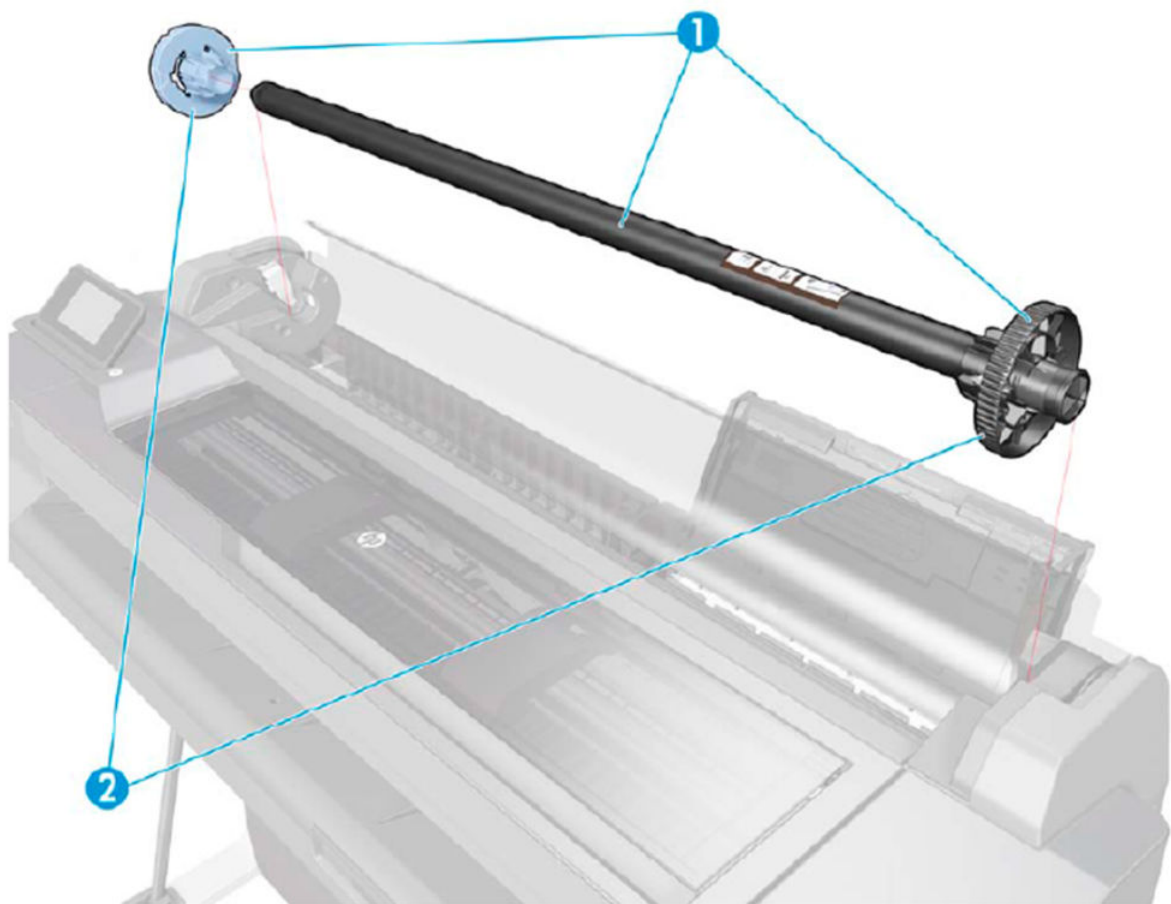

# Sensor Kit

	HP part number	Part description	Removal and installation reference	Comments
1	F9A30-67045	Printer sensor kit SV	<a href="#">Printer Sensor Kit SV on page 473</a>	

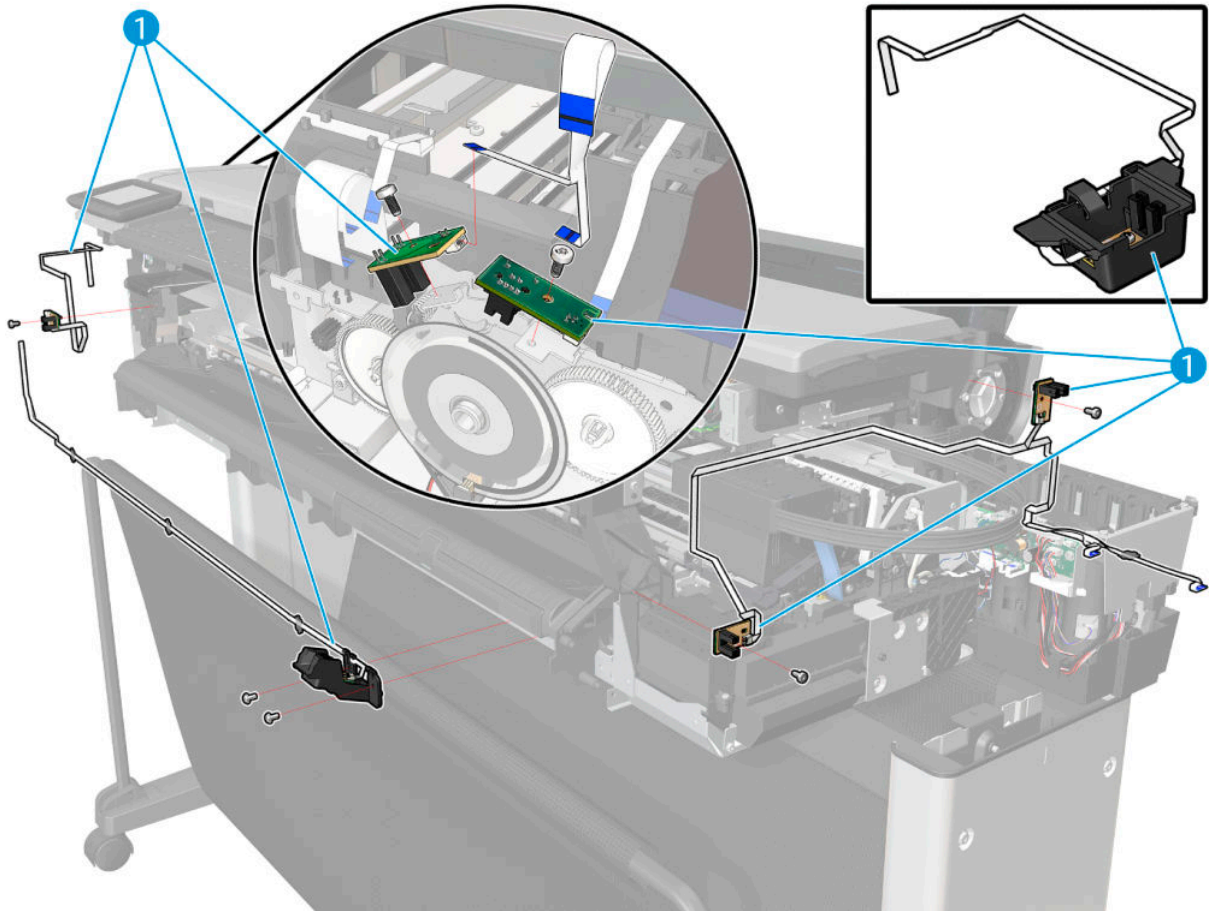

## Cable Kit

	HP part number	Part description	Removal and installation reference	Comments
1	F9A30-67046	Printer Cables kit SV		

- FFC-Encoder-Rewinder
- FFC-Paper-Feed-Sensors
- FFC-OutputTraySensor
- FFC-Power-Button\_MFP
- FFC-Service-Station Encoder
- USB Cable Front Panel to MPCA
- FFC\_Out Of Paper Sensor
- FFC-PHAdoor\_InkDoor
- FFC-Multisheet Tray sensor
- FFC-Printer Bundle Board to MPCA
- FFC-Front-Window MFP
- FFC-TopDoor SFP
- FFC-PowerButton-SFP
- FFC\_Encoder\_Pick motor
- FFC-NVM-Backup

## Ink tubes (RIDS) and Ink Supply Station (ISS)

	HP part number	Part description	Removal and installation reference	Comments
1	F9A30-67007	RIDS SV kit	<a href="#">RIDS (Ink Tubes) on page 494</a>	<b>IMPORTANT:</b> A new PHA is needed when the ink tubes are replaced. PHA is not included in the SV kit, needs to be ordered separately.
2	F9A30-67008	ISS SV kit	<a href="#">ISS on page 499</a>	

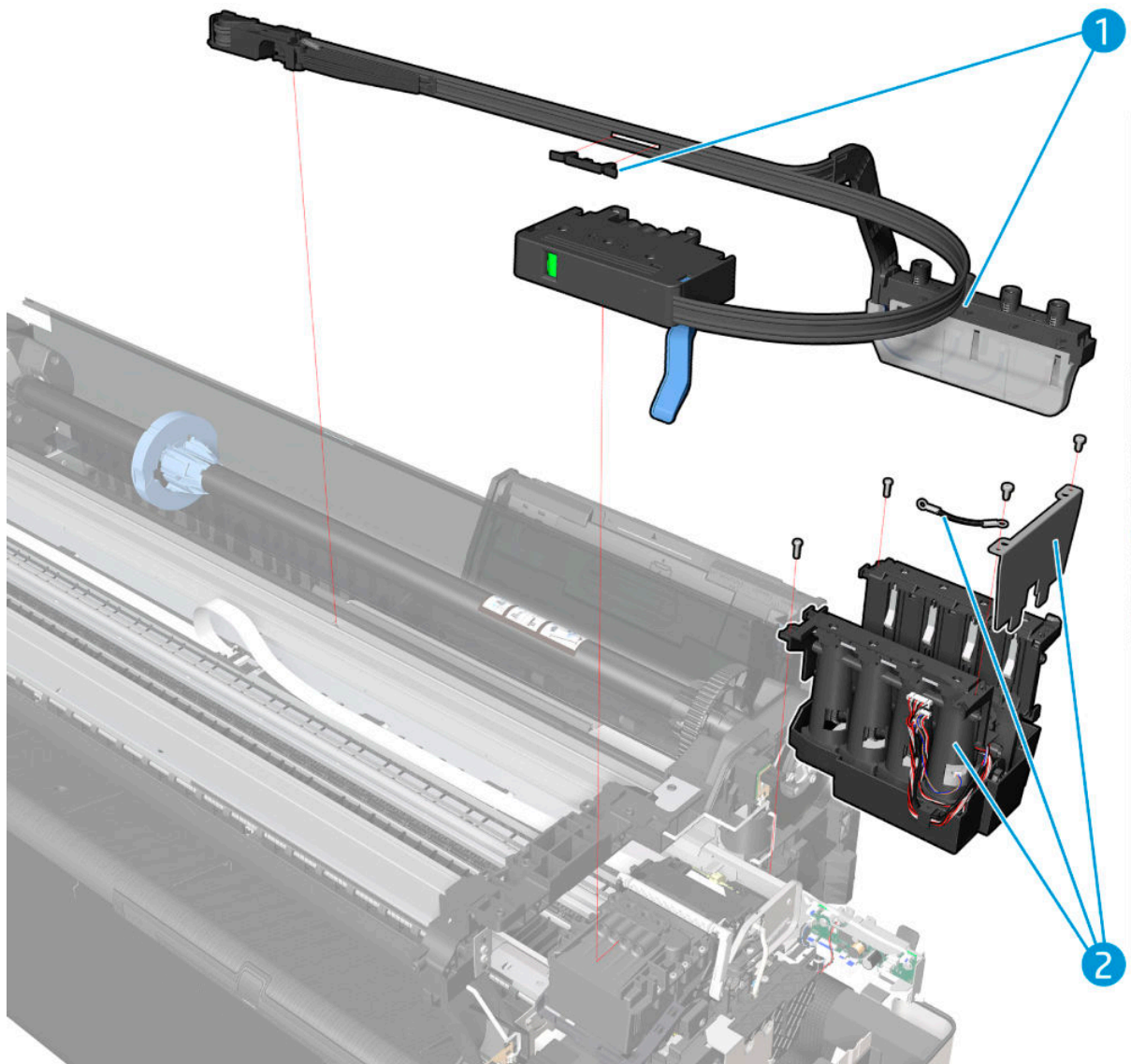



# Scanner Lid

	HP part number	Part description	Removal and installation reference	Comments
1	F9A30-67023	Top lid Mirror magnet SV kit (T830)	<a href="#">Top Lid Mirror and Magnet (HP DesignJet T830 MFP only) on page 511</a>	It contains 4 mirrors and 1 magnet. All 4 mirrors are identical and interchangeable.
2	F9A30-67017	Scanbars SV kit (T830)	<a href="#">Scanbars F9A30-67017 (HP DesignJet T830 MFP only) on page 425</a>	CSR A Kit contains 3 scanbars and 3 calibration surfaces
3	F9A30-67020	Assembly Pinch SV kit (T830)	<a href="#">Pressure Rollers flier on page 586</a>	CSR A
4	F9A30-67018	Scanbars SV kit (T830)	<a href="#">Scanbar FFC F9A30-67018 on page 466</a>	

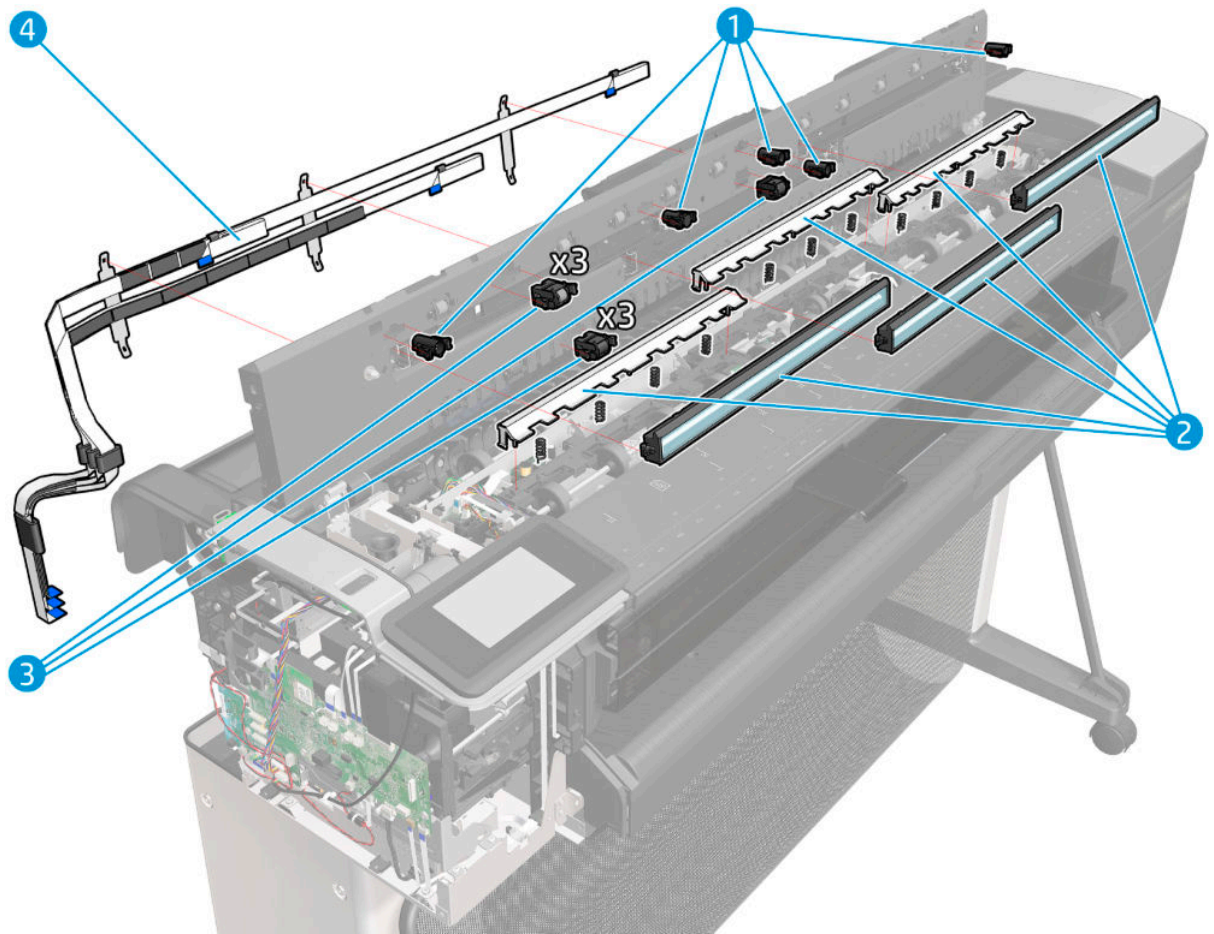

# Scanner Bottom Mech

	HP part number	Part description	Removal and installation reference	Comments
1	F9A30-67042	Bottom platen SV (T830)	<a href="#">Bottom Platen F9A30-67042 on page 431</a>	
2	F9A30-67026	Calibration slider SV kit (T830)	<a href="#">Calibration Slider on page 487</a>	There is a CSR SV kit for calibration surface only: "F9A30-67027 Calibration surface CSR SV kit"
3	F9A30-67025	Scanner feed shaft SV kit (T830)		SV kit contains only 1 feedshaft.
4	F9A30-67030	Assembly Latch SV kit (T830)		
5	F9A30-67039	Input platen SV (T830)	<a href="#">Input platen SV F9A30-67039 (HP DesignJet T830 MFP only) on page 513</a>	Includes L shape Torx tool.
6	F9A30-67033	Lower pinch assembly with mirror S (T830)	<a href="#">Lower Pinch Assembly with Mirror F9A30-67033 (HP DesignJet T830 MFP only) on page 492</a>	SV kits only contains 1 pinch assembly with mirror.
7	F9A30-67027	Calibration surface CSR SV kit	<a href="#">Calibration Surface F9A30-67027 on page 484</a>	SV kit contains 3 calibration surfaces and 12 springs.

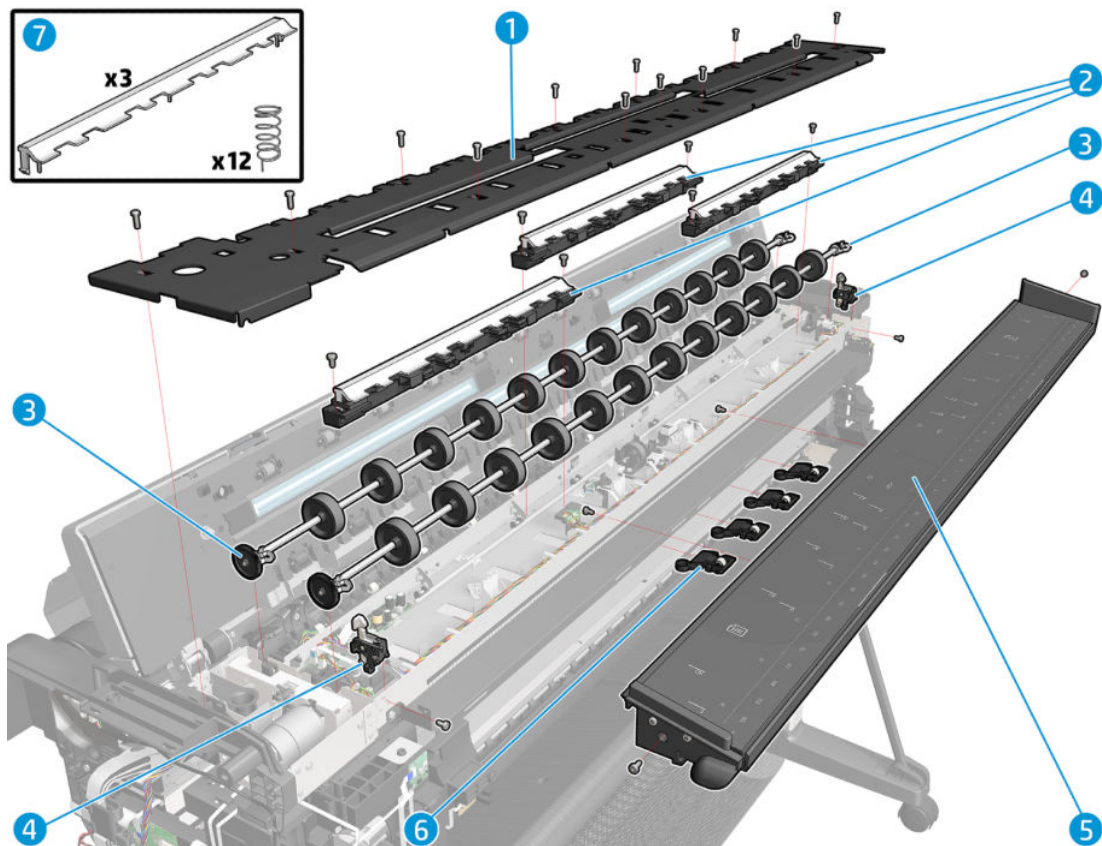

# Scanner Bottom-EE

	HP part number	Part description	Removal and installation reference	Comments
1	F9A30-67034	Bottom Cables SV kit (T830)	<a href="#">Bottom Cables F9A30-67034 on page 448</a>	
2	F9A30-67038	OPT wheel SV (T830)	<a href="#">OPT Wheel F9A30-60038 on page 453</a>	
3	F9A30-67031	Optical sensor SV kit (T830)	<a href="#">Sensor SV Kit F9A30-67031 on page 454</a>	
4	F9A30-67024	Scanner feed motor SV kit (T830)	<a href="#">Scanner Feed Motor F9A30-67024 on page 435</a>	
5	F9A30-67029	Scan Bundle PCA SV kit (T830)	<a href="#">Scan Bundle Board F9A30-67029 on page 433</a>	

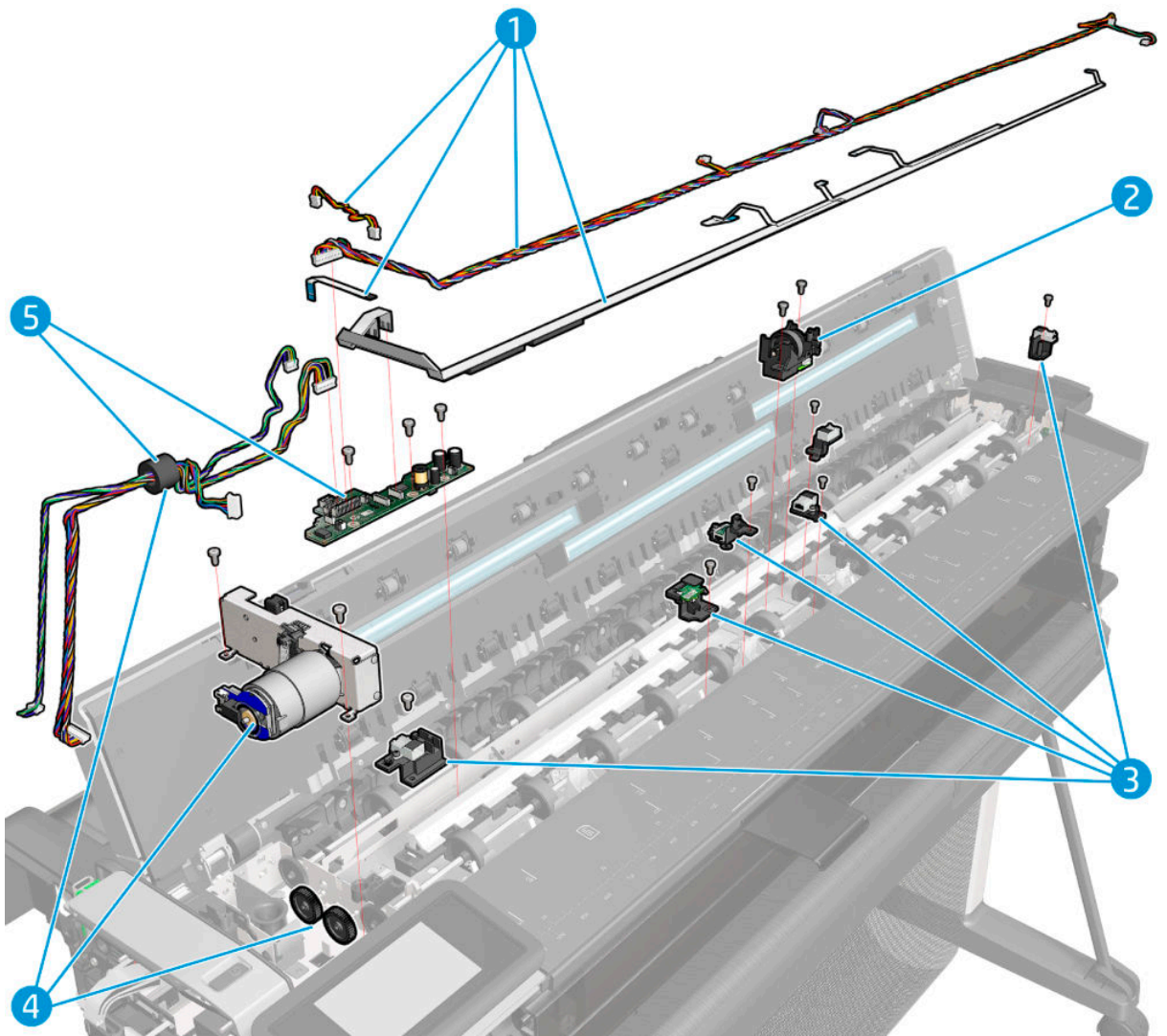

## Scanner Back

	HP part number	Part description	Removal and installation reference	Comments
1	F9A30-67040	Diverter SV (T830)	<a href="#">Diverter SV F9A30-67040 on page 516</a>	
2	F9A30-67062	Diverter Bottom Part SV (T830)	<a href="#">Diverter bottom part F9A30-67062 on page 520</a>	SV kit contains only 1 assembly.
3	F9A30-67019	Assembly Hinges SV kit (T830)	<a href="#">Hinges F9A30-67019 (HP DesignJet T830 MFP only) on page 437</a>	
4	F9A30-67028	Calibration Surface Gear Train SV kit (T830)	<a href="#">Calibration Surface Gear Train F9A30-67028 on page 489</a>	

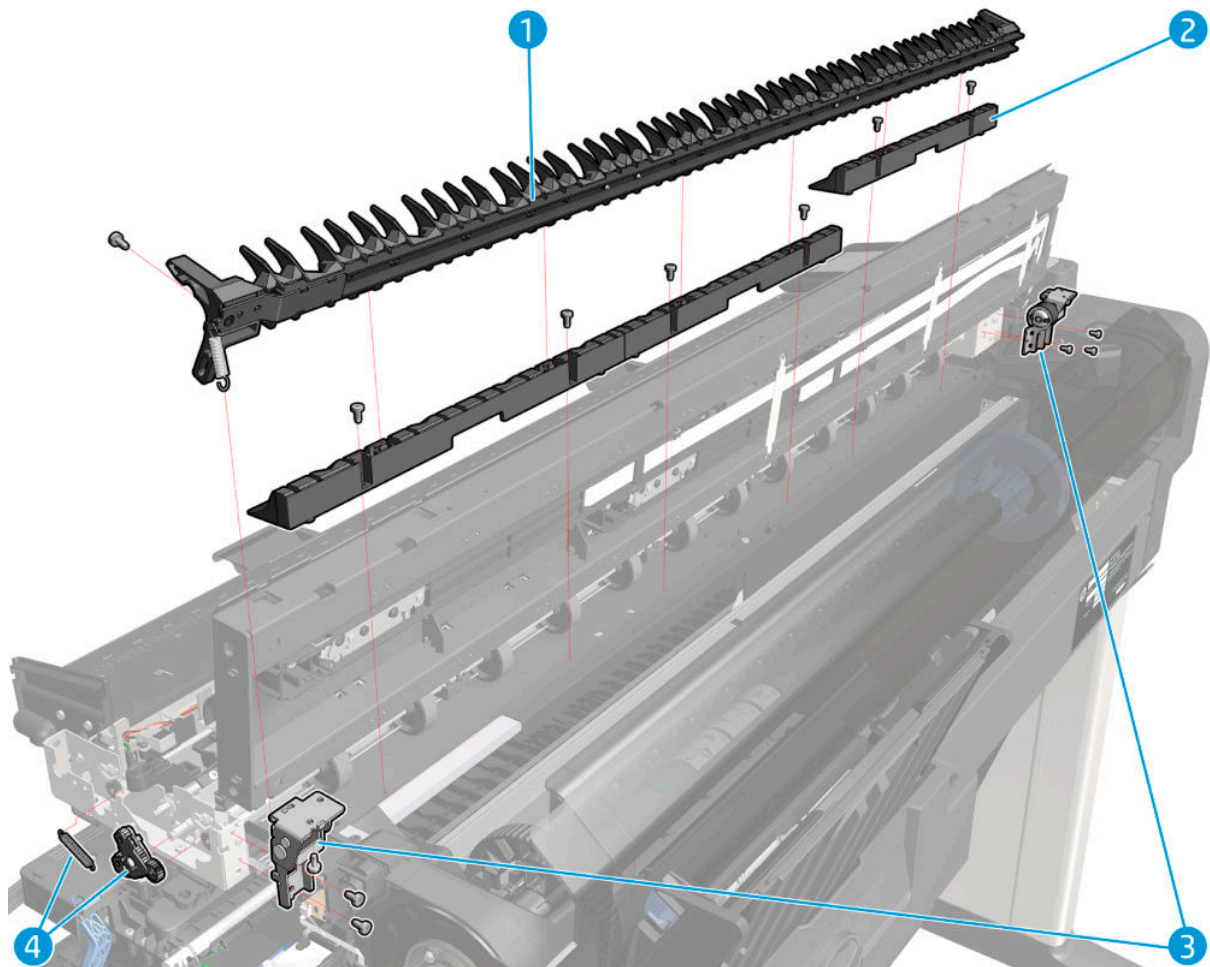

## Miscellaneous parts

HP part number	Part description	Comments
CQ890-60244	Friction repair Kit (lubrication kit)	Lubrication kit contains grease syringe for slider rod, aerosol shields and carriage bearings.
CQ890-67044	Left side spittoon SV	
CQ891-60021	Power Cord: EU SV KIT	CSR A
		8120-6314 EU, Denmark, South Africa, Switzerland
		8120-8699 UK & Middle East
CQ891-60022	Power Cord: AMS SV KIT	CSR A
		8120-6313 US, Canada & Mexico
		8120-8367 Argentina
		8121-1081 Brazil
		8121-0514 Chile
CQ891-60023	Power Cord: APJ SV KIT	CSR A
		8120-8699 Singapore, HK, MY
		8121-1168 India
		8121-0664 Thailand & Philippines
		8120-6316 Japan
		8120-8373 China
		8121-0963 Taiwan
		8120-8441 Korea
		8120-6314 Indonesia & Vietnam
8121-0870 Australia		
CQ894-67002	36 Upper roll media guide	See <a href="#">Upper-Roll Paper Guide on page 289</a>
F9A30-67055	PM Kit (Preventive Maintenance kit)	It contains: Carriage Motor, Carriage assembly with Belt and Trailing Cable and Cutter assembly.
F9A30-67060	Labels	CSR A Includes ink supply label, serial label, nameplates, and ink supply labels
F9J81A	Printhead Replacement Kit	CSR A



---

# 5 Removal and installation

## Parts in alphabetical order

[Back Cover on page 275](#)

[Bottom Cables F9A30-67034 on page 448](#)

[Bottom Platen F9A30-67042 on page 431](#)

[Bundle Board on page 406](#)

[Bundle Board FFC cable on page 408](#)

[Calibration Surface F9A30-67027 on page 484](#)

[Calibration Slider on page 487](#)

[Calibration Surface Gear Train F9A30-67028 on page 489](#)

[Carriage and Belt on page 344](#)

[Carriage Belt on page 351](#)

[Carriage Line Sensor on page 402](#)

[Carriage Motor on page 374](#)

[Central Cover on page 284](#)

[Cutter on page 379](#)

[Cutter Assembly on page 378](#)

[Cutter Bridge on page 380](#)

[Cutter Door F9A30-67006 on page 378](#)

[Cutter Guide on page 383](#)

[Diverter SV F9A30-67040 on page 516](#)

[Diverter bottom part F9A30-67062 on page 520](#)

[Encoder Disk on page 323](#)

[Encoder PCA and Index on page 319](#)

[Encoder Strip on page 300](#)

[Front Cover on page 261](#)

[Front Panel and Left Trim F9A30-67043 on page 526](#)

[Front Panel SFP F9A29-67008 on page 278](#)

[Front Window MFP SV Kit F9A30-67013 on page 502](#)

## Parts in removal order

[Top window SFP F9A29-67007 on page 258](#)

[Front Cover on page 261](#)

[Right Cover MFP SV Kit F9A30-67011 on page 264](#)

[Left Cover MFP SV Kit F9A30-67012 on page 268](#)

[Roll Cover on page 272](#)

[Back Cover on page 275](#)

[Front Panel SFP F9A29-67008 on page 278](#)

[Central Cover on page 284](#)

[Upper-Roll Paper Guide on page 289](#)

[Left Roll Support on page 292](#)

[Right Roll Support on page 297](#)

[Encoder Strip on page 300](#)

[Printer NVM backup PCA on page 305](#)

[Power Supply on page 308](#)

[Main PCA on page 311](#)

[Paper Motor on page 317](#)

[Encoder PCA and Index on page 319](#)

[Encoder Disk on page 323](#)

[Trailing Cable on page 326](#)

[Service Station on page 334](#)

[Prime Pump on page 340](#)

[Carriage and Belt on page 344](#)

[Carriage Belt on page 351](#)

[Right Gear Train Module on page 353](#)

[Starwheel Assembly on page 356](#)

[Output Shaft on page 358](#)

[Output Tray on page 365](#)

**Parts in alphabetical order**

[Hinges F9A30-67019 \(HP DesignJet T830 MFP only\) on page 437](#)

[Input platen SV F9A30-67039 \(HP DesignJet T830 MFP only\) on page 513](#)

[ISS on page 499](#)

[Latch \(Left\) F9A30-67030 on page 524](#)

[Latch \(Right\) F9A30-67030 on page 522](#)

[Left Cover MFP SV Kit F9A30-67012 on page 268](#)

[Left Roll Support on page 292](#)

[Left Spittoon on page 420](#)

[Lower Pinch Assembly with Mirror F9A30-67033 \(HP DesignJet T830 MFP only\) on page 492](#)

[Main PCA on page 311](#)

[Multi-Sheet Tray Assembly on page 367](#)

[Multi-Sheet Tray Assembly Extensions on page 368](#)

[OPT Wheel F9A30-60038 on page 453](#)

[Sensor SV Kit F9A30-67031 on page 454](#)

[Out-Of-Paper Sensor on page 388](#)

[Out-Of-Paper Sensor Cable on page 392](#)

[Output Platen on page 370](#)

[Output Shaft on page 358](#)

[Output Tray on page 365](#)

[Output Tray Extender Sensor Cable on page 398](#)

[Output Tray Sensor Assembly on page 395](#)

[Paper Motor on page 317](#)

[Pinchwheels on page 414](#)

[Power Supply on page 308](#)

[Prime Pump on page 340](#)

[Printer NVM backup PCA on page 305](#)

[Printer Sensor Kit SV on page 473](#)

[Rear Cover \(MFP only\) on page 464](#)

[Refeed Preventer on page 504](#)

[RIDS \(Ink Tubes\) on page 494](#)

[Right Cover MFP SV Kit F9A30-67011 on page 264](#)

[Right Gear Train Module on page 353](#)

[Right Roll Support on page 297](#)

**Parts in removal order**

[Multi-Sheet Tray Assembly on page 367](#)

[Multi-Sheet Tray Assembly Extensions on page 368](#)

[Output Platen on page 370](#)

[Carriage Motor on page 374](#)

[Cutter Assembly on page 378](#)

[Cutter Door F9A30-67006 on page 378](#)

[Cutter on page 379](#)

[Cutter Bridge on page 380](#)

[Cutter Guide on page 383](#)

[Multi-Sheet Tray Sensor Assembly on page 385](#)

[Out-Of-Paper Sensor on page 388](#)

[Out-Of-Paper Sensor Cable on page 392](#)

[Output Tray Sensor Assembly on page 395](#)

[Output Tray Extender Sensor Cable on page 398](#)

[Carriage Line Sensor on page 402](#)

[Bundle Board on page 406](#)

[Bundle Board FFC cable on page 408](#)

[Pinchwheels on page 414](#)

[Left Spittoon on page 420](#)

[Scanner Top Cover F9A30-67015 on page 423](#)

[Scanbars F9A30-67017 \(HP DesignJet T830 MFP only\) on page 425](#)

[Top Cover Button Latch F9A30-67016 \(HP DesignJet T830 MFP only\) on page 430](#)

[Bottom Platen F9A30-67042 on page 431](#)

[Scan Bundle Board F9A30-67029 on page 433](#)

[Scanner Feed Motor F9A30-67024 on page 435](#)

[Hinges F9A30-67019 \(HP DesignJet T830 MFP only\) on page 437](#)

[Scanner Feedshaft \(Front\) F9A30-67025 on page 440](#)

[Scanner Feedshaft \(Rear\) on page 446](#)

[Bottom Cables F9A30-67034 on page 448](#)

[OPT Wheel F9A30-60038 on page 453](#)

[Sensor SV Kit F9A30-67031 on page 454](#)

[Rear Cover \(MFP only\) on page 464](#)

[Scanbar FFC F9A30-67018 on page 466](#)



**Parts in alphabetical order**

[Roll Cover on page 272](#)

[Scan Bundle Board F9A30-67029 on page 433](#)

[Scanbars F9A30-67017 \(HP DesignJet T830 MFP only\) on page 425](#)

[Scanner Feed Motor F9A30-67024 on page 435](#)

[Scanner Feedshaft \(Front\) F9A30-67025 on page 440](#)

[Scanner Feedshaft \(Rear\) on page 446](#)

[Scanner Module on page 505](#)

[Scanbar FFC F9A30-67018 on page 466](#)

[Scanner Top Cover F9A30-67015 on page 423](#)

[Sensor SV Kit F9A30-67031 on page 454](#)

[Service Station on page 334](#)

[Starwheel Assembly on page 356](#)

[Top window SFP F9A29-67007 on page 258](#)

[Top Cover Button Latch F9A30-67016 \(HP DesignJet T830 MFP only\) on page 430](#)

[Top Lid Mirror and Magnet \(HP DesignJet T830 MFP only\) on page 511](#)

[Trailing Cable on page 326](#)

[Upper-Roll Paper Guide on page 289](#)

**Parts in removal order**

[Printer Sensor Kit SV on page 473](#)

[Calibration Surface F9A30-67027 on page 484](#)

[Calibration Slider on page 487](#)

[Calibration Surface Gear Train F9A30-67028 on page 489](#)

[Lower Pinch Assembly with Mirror F9A30-67033 \(HP DesignJet T830 MFP only\) on page 492](#)

[RIDS \(Ink Tubes\) on page 494](#)

[ISS on page 499](#)

[Front Window MFP SV Kit F9A30-67013 on page 502](#)

[Refeed Preventer on page 504](#)

[Scanner Module on page 505](#)

[Top Lid Mirror and Magnet \(HP DesignJet T830 MFP only\) on page 511](#)

[Input platen SV F9A30-67039 \(HP DesignJet T830 MFP only\) on page 513](#)

[Diverter SV F9A30-67040 on page 516](#)

[Diverter bottom part F9A30-67062 on page 520](#)

[Latch \(Right\) F9A30-67030 on page 522](#)

[Latch \(Left\) F9A30-67030 on page 524](#)

[Front Panel and Left Trim F9A30-67043 on page 526](#)

# Introduction

This chapter is a step-by-step guide to the removal and installation of the key components of the printer. Use the illustrations for each procedure to identify the parts referred to in the text.

---

 **NOTE:** Before using this chapter to remove and install a new component, always make sure that you have performed the relevant service test. If the test passes you will not need to replace the component.

 **NOTE:** We recommend that, every time a part is removed, the Line Sensor and the Encoder Strip are cleaned. See [Clean the Carriage Line Sensor on page 530](#) and [Clean the Encoder Strip on page 531](#).

---

## Safety precautions

Review the instructions identified by WARNING and CAUTION symbols before you service the printer. Follow these warnings and cautions for your protection and to avoid damaging the printer.

Serious shock hazard leading to death or injury may result if you do not take the following precautions:

- Switch the printer off and disconnect it from the power source prior to performing any maintenance.
- Prevent water or other liquids from running onto electrical components or circuits, or through openings in the module.

---

 **IMPORTANT:** You are recommended to wear gloves when removing or installing any part, even if it is not mentioned in the removal or installation procedure.

---

## Electrostatic Discharge (ESD) Precautions

To prevent damage to the printer's circuits from high-voltage electrostatic discharge (ESD):

1. Do not wear clothing that is subject to static build-up.
2. Do not handle integrated circuits (ICs) in carpeted areas.
3. Do not remove an IC or a Printed-Circuit Assembly (PCA) from its conductive foam pad or conductive packaging until you are ready to install it.
4. Ground (earth) your body while disassembling and working on the printer.
5. After removing a cover from the printer, attach an earthing (ground) lead between the PCA common and earth (ground). Touch all tools to earth (ground) to remove static charges before using them on the printer.
6. After removing any PCA from the printer, place it on a conductive foam pad or into its conductive packaging to prevent ESD damage to any ICs on the PCA.

## Required tools

All the special tools and equipment required to disassemble, service, and repair the printer are provided in the Toolkit P/N Q6683-67001. Some tools can be ordered separately from the toolkit.

The Toolkit contains the following tools:

Description/Comments	HP part number
Alcohol (100cc isopropyl alcohol)	Q6675-60091
Cleaning Cloth	9300-2531
Protective Plastic Gloves	Q6675-60035
Tweezers	Q6675-60037
Flat screwdriver	
Torx screwdriver 6, 10	
Pliers	
Pinchwheel alignment tool	
Media driver tool	
Spanner number 13	
Oil dispenser	
Insert spring tool	
T15 screwdriver	
Lubricant oil	
Flex contacts cleaning tool	

You may also need the following standard hand tools:

Description/Comments	Size
Long Torx Screwdriver	1/4 inch drive
Torx bit (75 mm)	8
	10
	15
	20

## Customer Self Repair parts

Some printer parts are designated Customer Self Repair (CSR) parts, which means that a faulty part can be replaced by the customer. Non-CSR parts need to be replaced by an engineer. There are two categories of CSR parts:

- **CSR A:** Customer self-repair is mandatory, as mentioned in the printer's warranty statement. If HP is asked to replace such parts, the customer will be charged for travel and labor costs. Parts should be replaceable by end users (customers) from a mechanical perspective within 5 minutes, with simple or no tools required. Examples include spindles and cartridges.
- **CSR B:** Parts are easy to replace, but some knowledge of the printer and technical skills may be required. The customer can decide whether to replace the part or to call for an engineer.

The CSR parts are listed below.

Part number	Description	CSR type	Flyer
F9J81A	Printhead	CSR A	Yes
CQ890-67007	Multi-Sheet Tray Assembly	CSR A	Yes
CQ890-67019	Output Tray (Pro)	CSR B	Yes
CQ890-67047	Multi-Sheet Tray Extensions	CSR A	Yes
CQ890-67090	Cutter CSR SV kit	CSR A	Yes
CQ891-60021	Power Cords EU SV Kit	CSR A	No
CQ891-60022	Power Cords AMS SV Kit	CSR A	No
CQ891-60023	Power Cords APJ SV Kit	CSR A	No
CQ893-67008	Spindle (36)	CSR A	No
CQ893-67009	Spindle Hubs CSR A	CSR A	No
CQ893-67018	Output Tray Sensor	CSR B	Yes
CQ894-67001	Front Cover (36)	CSR A	Yes
F9A30-67006	Cutter Door kit (ink door kit)	CSR A	No
F9A30-67014	Ink door	CSR A	Yes
F9A30-67020	Scanner Rollers assy	CSR A	Yes
F9A30-67035	Refeed preventer SV	CSR A	Yes
F9A30-67053	OOPS Sensor flag w/tap	CSR B	Yes
F9A30-67056	Stand Left Leg Assy	CSR B	Yes
F9A30-67057	Stand Right Leg Assy	CSR B	Yes
F9A30-67058	Stand Basket SV kit	CSR A	Yes
F9A30-67059	Stand HW kit	CSR A	No
F9A30-67060	Labels	CSR A	No
F9A30-67064	Calibration Scanner Plot SV kit	CSR A	No

Copies of most of the fliers can be found in the appendices to this manual: see [CSR fliers on page 567](#).

### For further information

- CSR Corporate Standards: <http://standards.corp.hp.com/smc/hpstd/AHP0001501.htm>
- CSR Web site: <http://www.hp.com/go/csrrparts/>
- HP Parts Page: <http://partsurfer.hp.com/>
- HP Parts Store: <http://www.hp.com/go/hpparts>

## Videos available

The following videos are available in the HP Services Media Library:

- Public, available to customers: Ink Cartridge Cover, Out-Of-Paper Sensor, Output Tray, Output Tray Sensor.
- For service technicians only: Carriage, Carriage Motor, Central Cover, Cutter, Front Panel, Main PCA, Output Platen, Pinchwheels, Starwheels and Output Shaft, Trailing Cable.

### HP Services Media Library

- HP intranet access: <http://thesml.hp.com/>
- HP external/Customer Self Repair: <http://www.hp.com/go/sml>
- HP Partner via regional Partner portal: <http://www.hp.com/go/psml>

## Recommended checks after replacing parts

After replacing a part, we recommend checking the status of the printer as follows:

1. Turn on the printer and check that there is no system error.
2. Print the print-quality diagnostic report on an A4 or US Letter sheet of paper and check that there are no problems.
3. Load a roll of paper and perform some form feeds and cuts.

For some parts, further actions are required:

- After replacing the Main PCA, check for firmware updates and set up Web Services.
- After replacing the Service Station or Carriage Assembly, perform the appropriate preventive maintenance reset. See [Extended Support menu on page 216](#).

## Top window SFP F9A29-67007

 **NOTE:** The Top Window is also known as the Central Window.

---

1. Open the Top Window.



2. Unclip the indicated clip of the Front Panel.

 **NOTE:** Image shown is from another product, and for reference only.

---

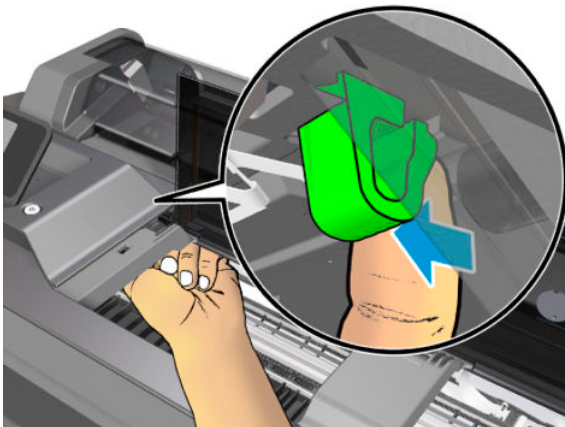

3. Push up the clip as shown below.

 **NOTE:** Image shown is from another product, and for reference only.

 **NOTE:** Do not force too much pushing the clip up as the Front Panel movement might be limited by the USB cable. The purpose of pushing the clip up is only to create space in order to slide the window to the left (not to fully remove the Front Panel).

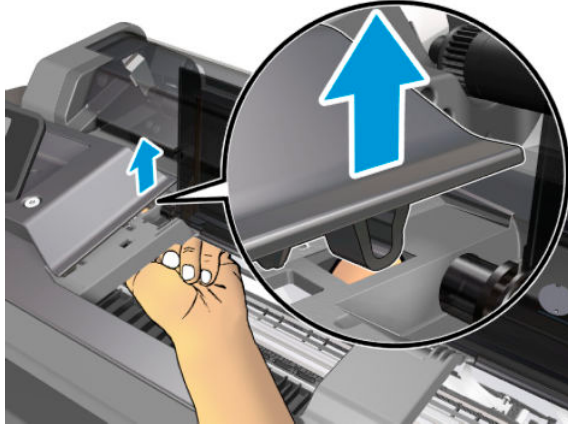

4. Press down the flange of the Top Cover in order to slide the Window to the left.

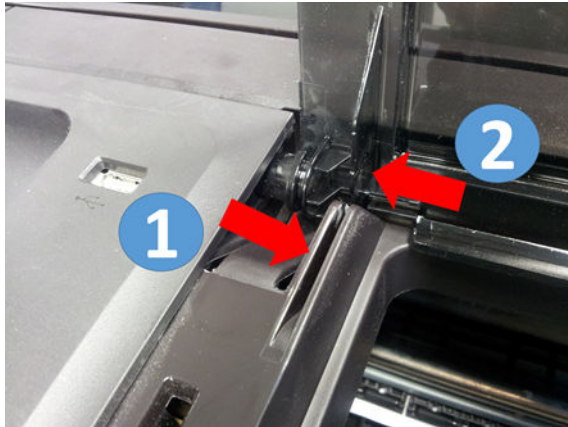

5. Make sure you have slid the Top Window as far as possible to the left.



6. Move the right side of the Top Window upwards.



7. Remove the Top Window.

**⚠ CAUTION:** There is a damper.

---



8. After a new Top Cover is installed, remember to snap the Front Panel clip, that was released earlier, back into place.

### Installation

- ▲ Install the Top Window by reversing the removal process.



# Front Cover

## Removal

1. Switch off the printer.



2. Lock the four wheels.

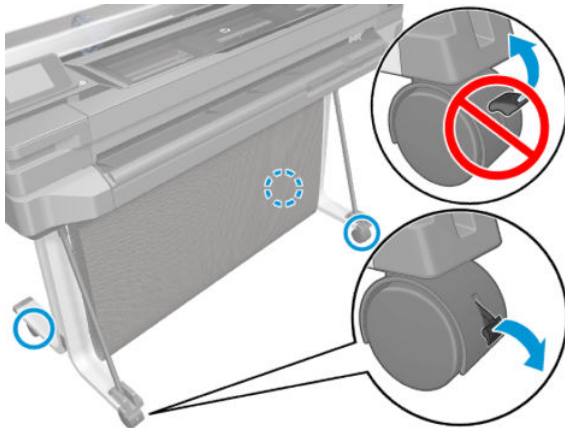

3. Unclip the lower part of the Front Cover (1) and unclip the upper part (2) from locations along the length of the cover:

- 36 inch printer: 4 clips from the bottom and 4 from the top.

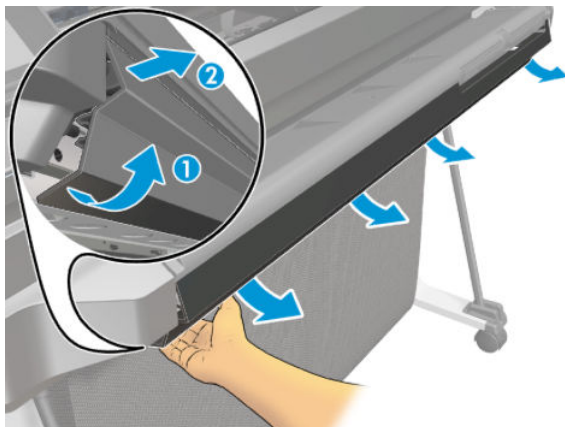

**4. Remove the Front Cover.**

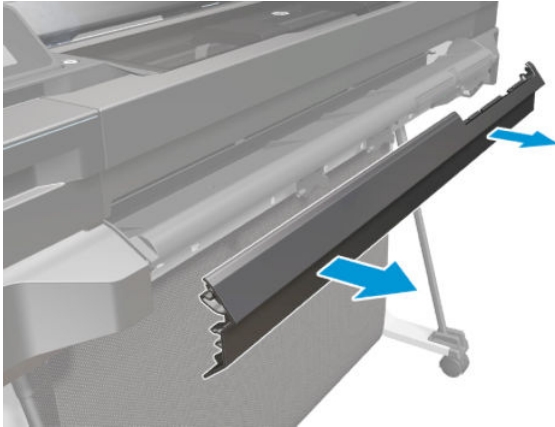

**Installation**

**1. The underside of the Front Cover:**

- 36 inch printer: 8 clips.

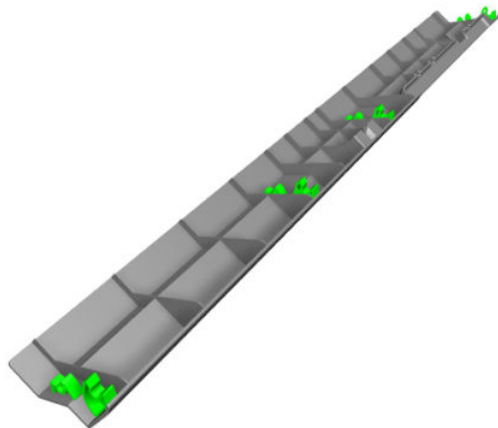

**2. Detail showing where the clips must be attached.**

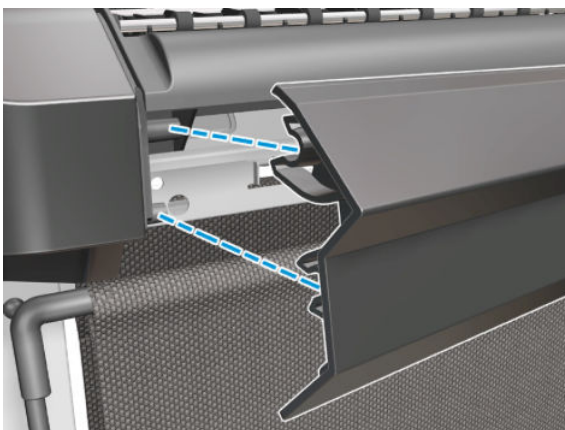

3. Snap the Front Cover into place, making sure that each of the clips is fully engaged.

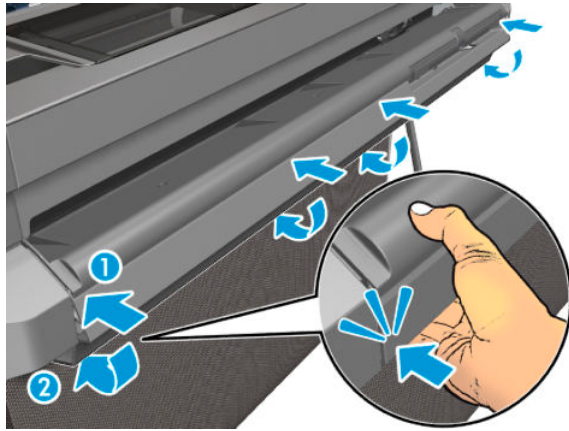

# Right Cover MFP SV Kit F9A30-67011

## Removal

1. Remove the Front Cover, see [Front Cover on page 261](#).
2. Remove one screw.



3. Open the Cartridges Door.



4. Remove the Cartridges.



5. Remove the two screws.

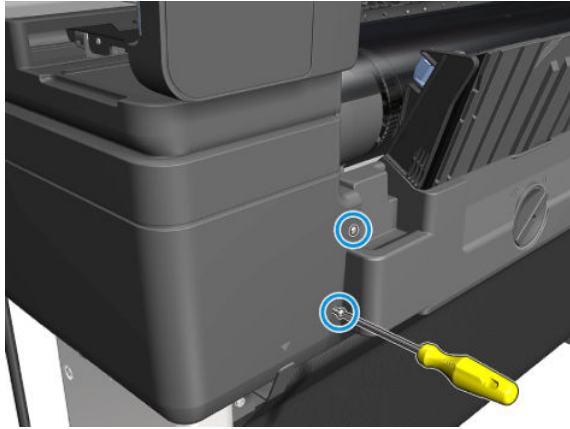

6. Open the Roll Cover.

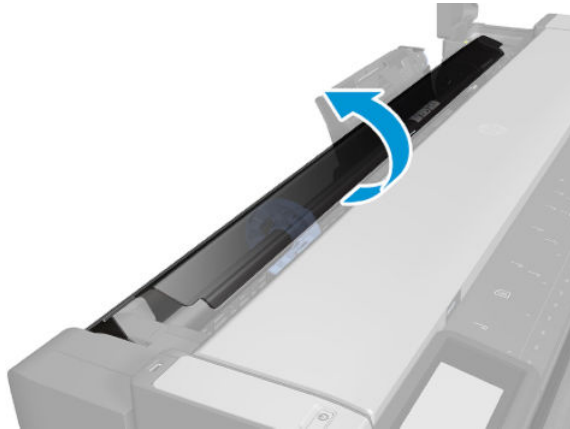

7. Remove one screw.

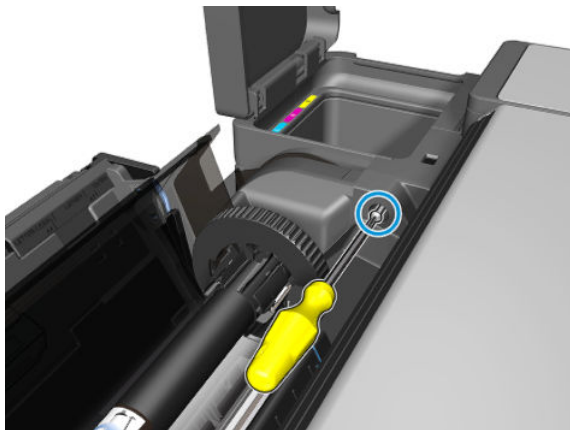

8. Open the Printhead door.

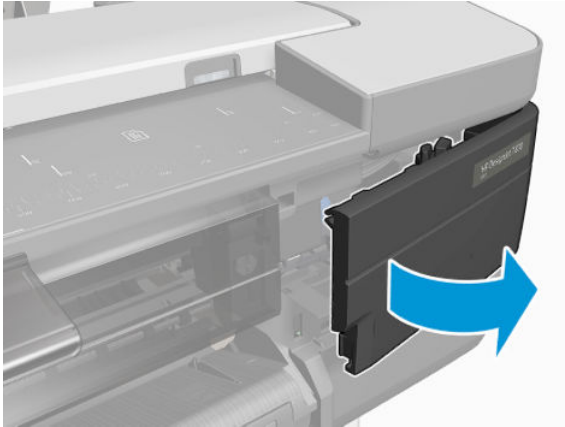

9. Remove one screw.

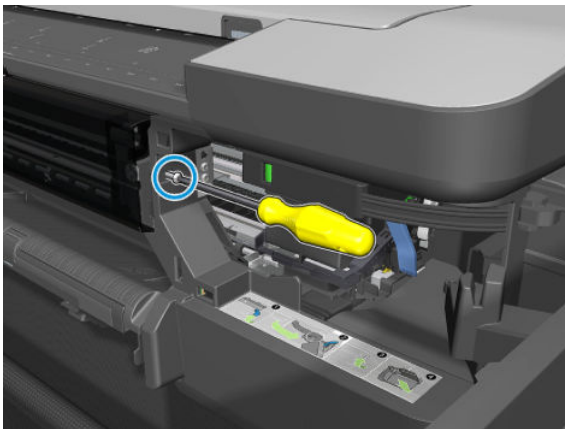

10. Close the Carriage door (**VERY IMPORTANT**).

**⚠ CAUTION:** Failure to follow will cause potential damage to ink tubes.

---

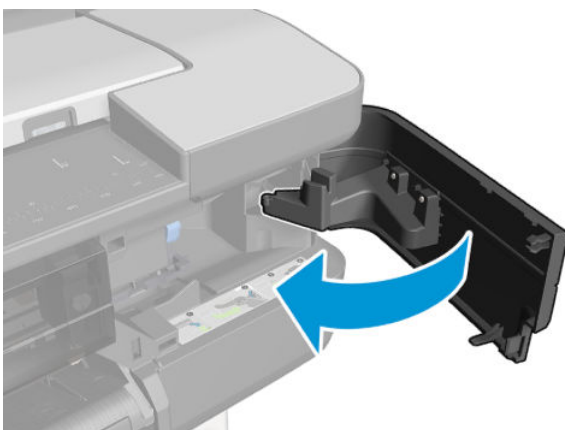

11. Be sure the Cartridges Door is open (**VERY IMPORTANT**).

 **CAUTION:** Failure to follow will cause potential damage to cartridge door tab.

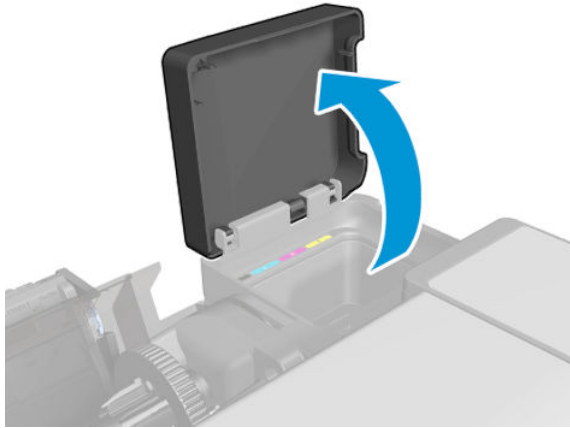

12. Remove the Right Cover.

 **IMPORTANT:** Remove the Right Cover with the **Ink Door open** and the **PHA Door closed**.

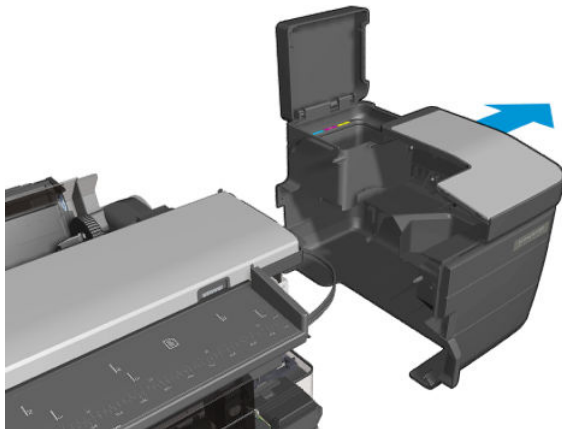

## Installation

▲ Install the Right Cover by reversing the removal process.

# Left Cover MFP SV Kit F9A30-67012

## Removal

1. Remove the Front Cover, see [Front Cover on page 261](#).
2. Remove the two screws.



3. Open the Cutter Door.



4. Remove one screw.





5. Remove the two screws.

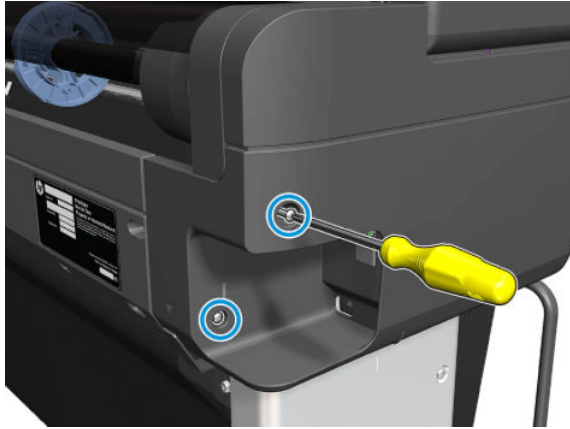

6. Open the Roll Cover.

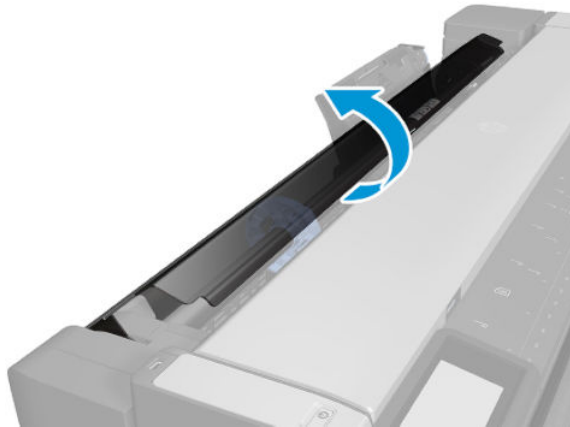

7. Remove one screw.

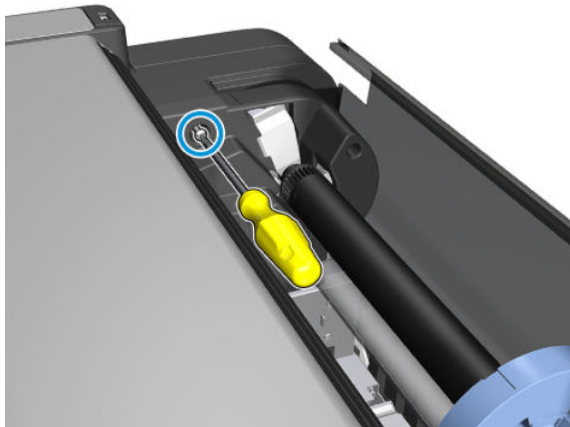

8. **MFP only:** Open the Scanner.

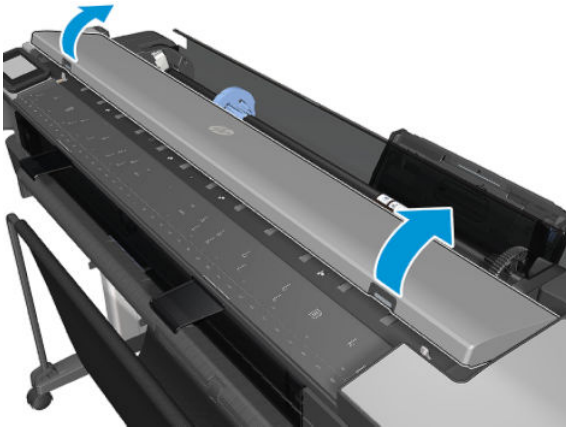

9. **MFP only:** Remove two screws.

 **NOTE:** A long T15 bit is required to reach the screws.

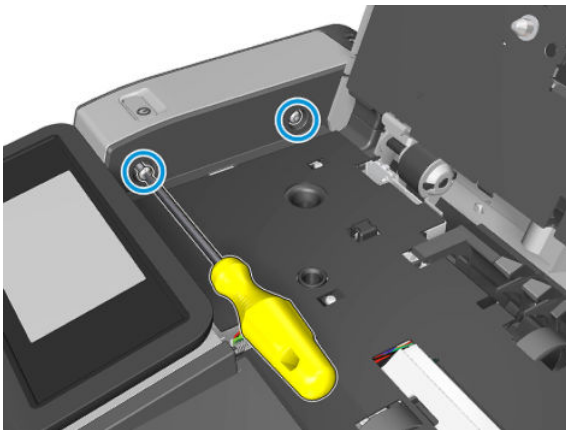

10. Remove the left cover.

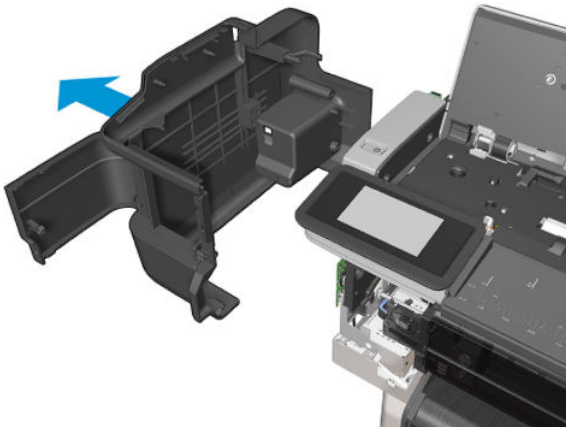

## Installation

- ▲ Install the Left Cover by reversing the removal process.

---

 **CAUTION:** Be careful with Front Panel FFC cable in the front area when replacing the cover.

---

# Roll Cover

## Removal

1. Switch off the printer and remove the power cable.
2. Remove the Front Cover, see [Front Cover on page 261](#).
3. Remove the Cutter Door, see [Cutter Door F9A30-67006 on page 378](#).
4. Remove the Left Cover, see [Left Cover MFP SV Kit F9A30-67012 on page 268](#).
5. Remove the Right Cover, see [Right Cover MFP SV Kit F9A30-67011 on page 264](#).
6. Close the Roll Cover.



7. Remove three T-15 screws from the left side of the Roll Cover.

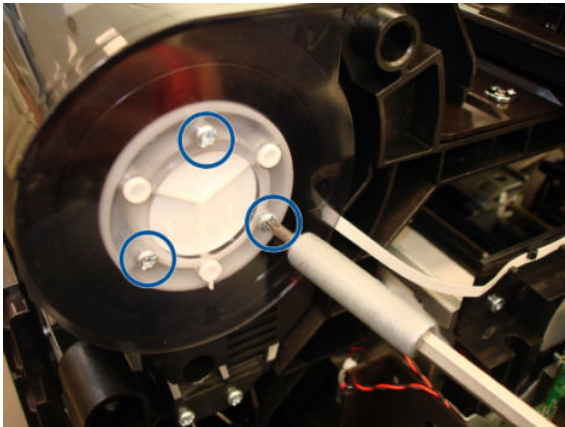

8. Remove three T-15 screws from the right side of the Roll Cover.

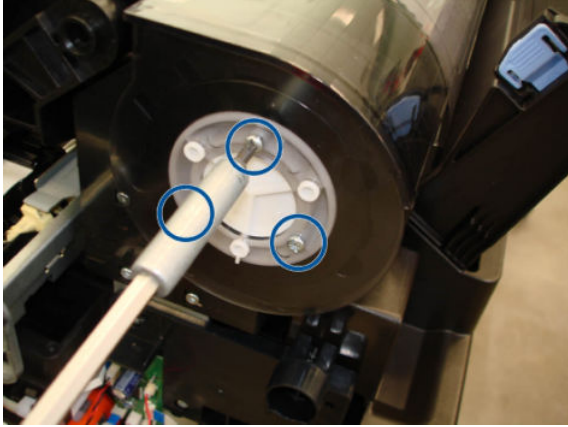

9. Unclip and detach the left side of the Roll Cover, bending it carefully.

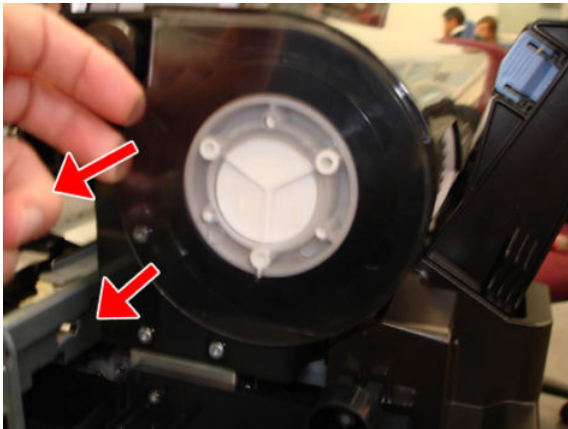

10. Unclip and detach the right side of the Roll Cover, bending it carefully.

**⚠ CAUTION:** Take care not to damage the Rewinder cables.

---

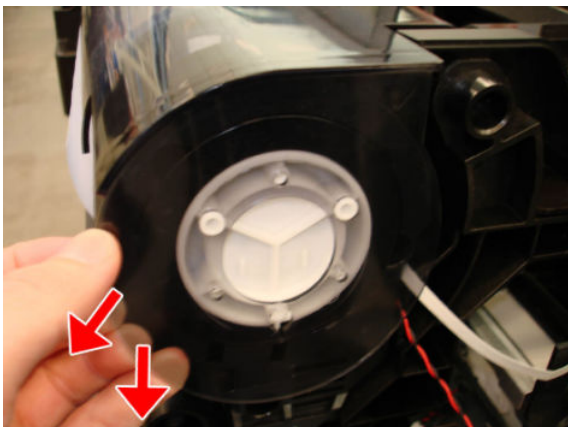

11. Remove the Roll Cover.

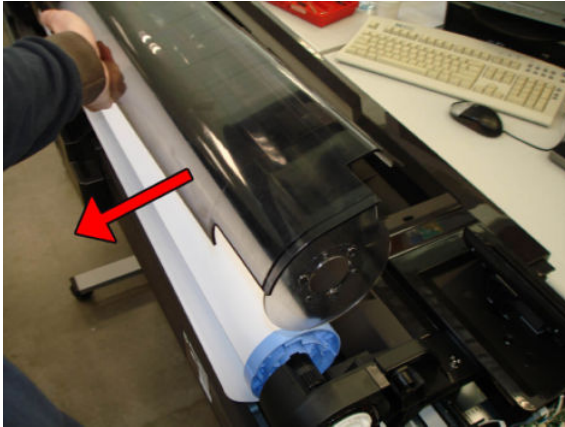

### Installation

1. When installing the Roll Cover, ensure that the key is correctly installed when attaching the Roll Cover to the Gear Damper.

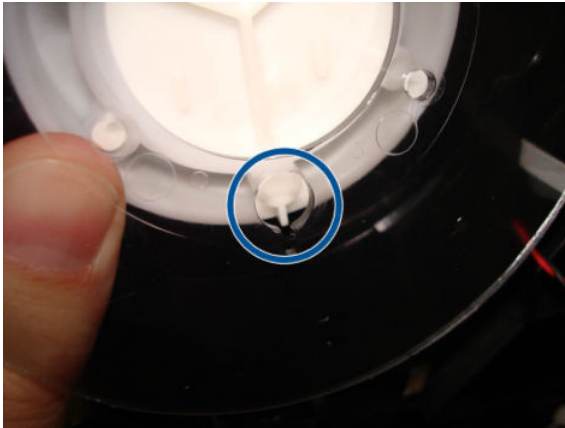

2. Install the Roll Cover by reversing the removal process.

# Back Cover

## Removal

1. Switch off the printer and remove the power cable.
2. Remove the Multi-Sheet Tray, see [Multi-Sheet Tray Assembly on page 367](#).
3. Remove four T-10 screws.



4. Unclip the four bottom clips.

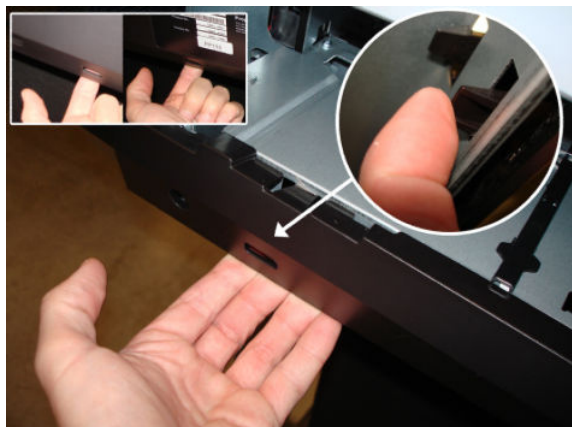

5. Unclip the left top clip.



6. Unclip the two top clips.



7. Remove the Back Cover.



## Installation

1. When installing the Back Cover, take care not to disconnect or damage the cables at the rear.



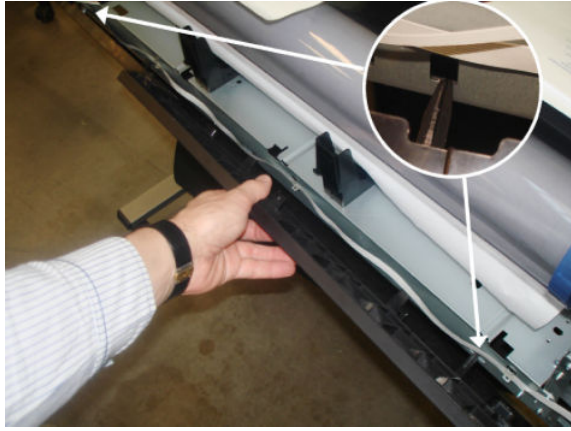

2. Install the Back Cover by reversing the removal process.

# Front Panel SFP F9A29-67008

## Removal

1. Switch off the printer and remove the power cable.
2. Remove the Front Cover, see [Front Cover on page 261](#).
3. Remove the Cutter Door, see [Cutter Door F9A30-67006 on page 378](#).
4. Remove the Left Cover, see [Left Cover MFP SV Kit F9A30-67012 on page 268](#).
5. Disconnect the Power Button FFC, the FP cable and the black USB cable.

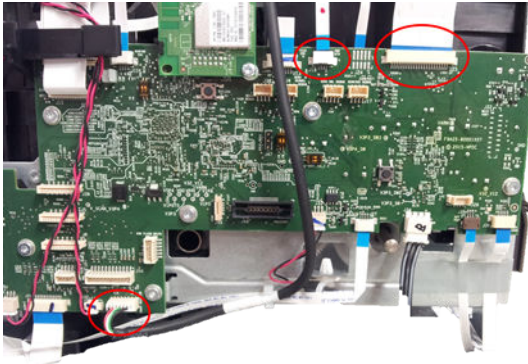

6. Move up the Front Panel if it is in the flat position.

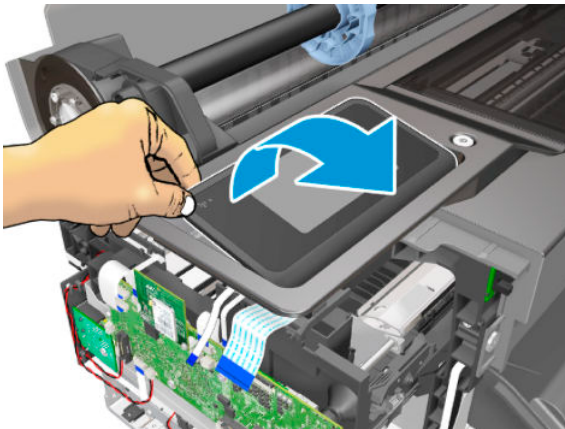

7. Remove one T15 screw.



**NOTE:** Image shown is from another product, and for reference only. This step is different for both models.

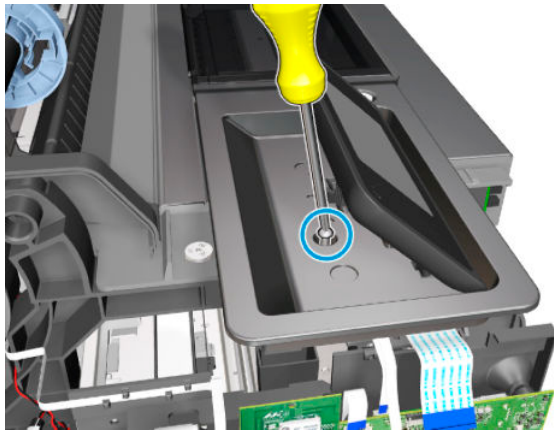

8. Open the Top Cover.



9. Unclip the first of the 4 clips.

 **NOTE:** Image shown is from another product, and for reference only. This step is different for both models.

 **NOTE:** See image below for Front Panel clip location for T730 model.

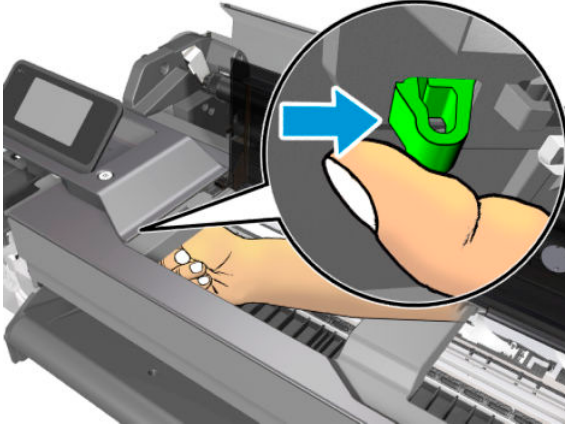

10. Push up after unclipping.

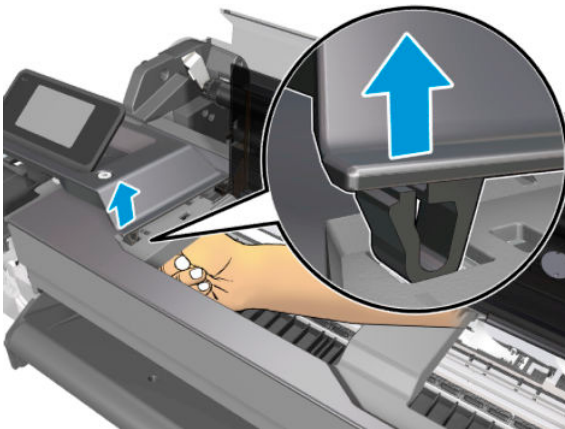

11. Unclip the second clip as indicated here.

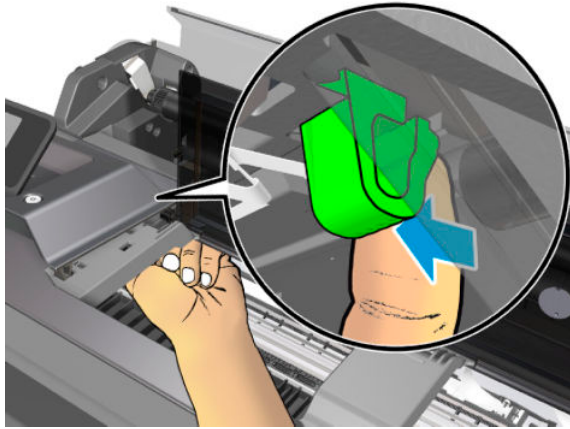

12. Unclip the clip indicated here.

 **NOTE:** Image shown is from another product, and for reference only.

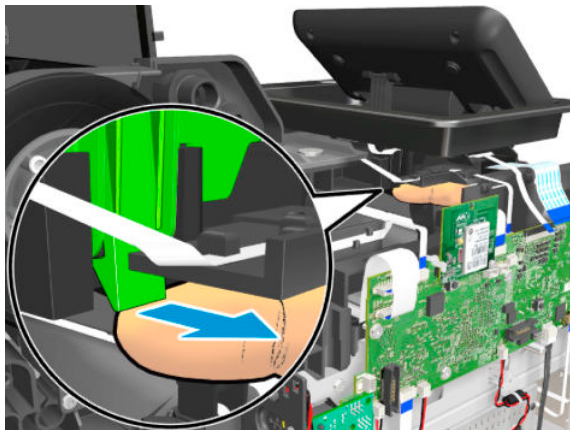

13. Push up after unclipping.

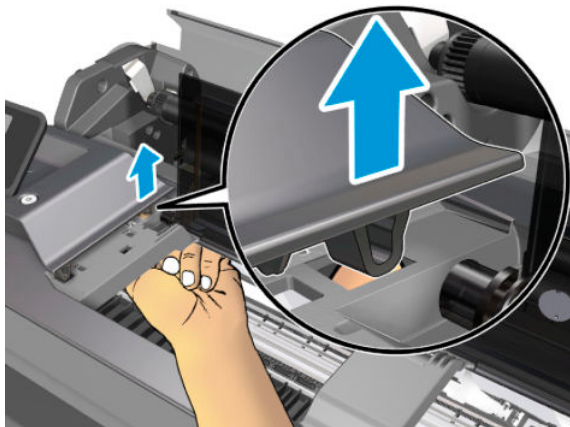

- Slide up the Front Panel carefully through the ferrite, taking care not to damage the flat cable attached to the ferrite.

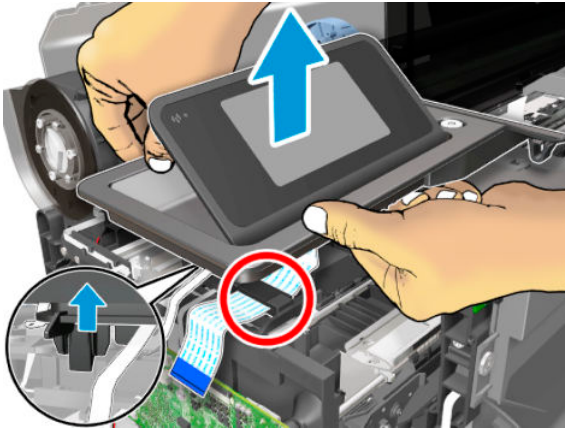

**CAUTION:** Ferrite is difficult to remove. Care need to be taken not to damage cable or MPCA board.

- Remove the flat cable from the ferrite.

**NOTE:** Image shown is from another product, and for reference only. This step is different for both models.

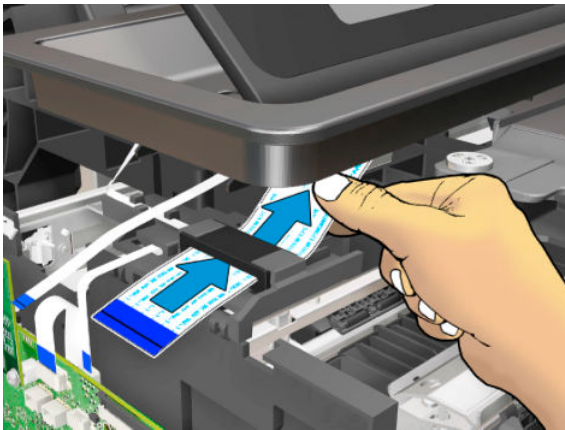

- Unroute the USB cable before removing completely the FP.

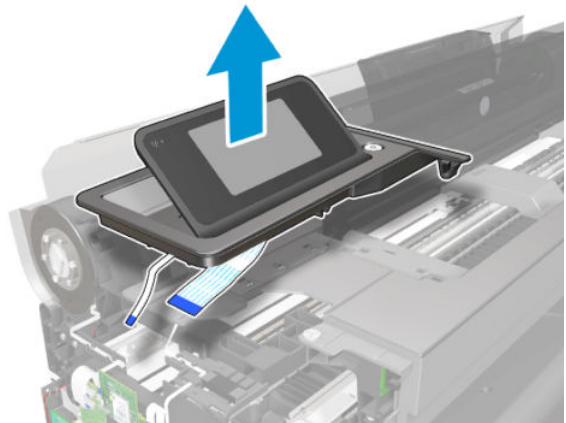

## Installation

1. When you install the Front Panel reversing the removal process, be careful to insert the indicated parts inside.

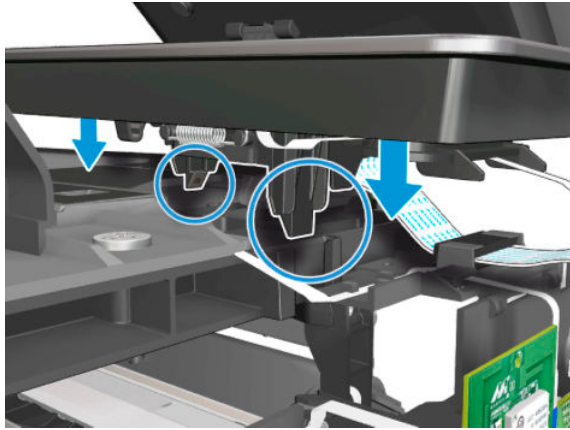

2. If the Front Panel cable is not correctly connected, the printer can sometimes start up with colors that are different from the normal colors (orange, blue), as shown below.

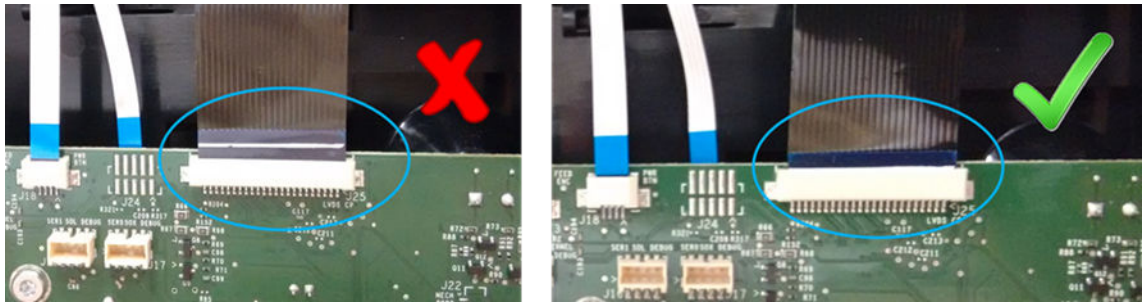

**⚠ CAUTION:** Don't remove the FFC from the Front Panel side, as there is no access for reconnecting:

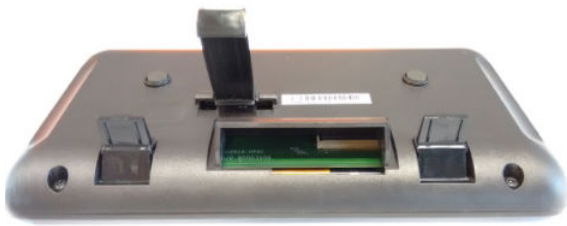

# Central Cover

## Removal

1. Switch off the printer and remove the power cable.
2. Remove the Front Cover, see [Front Cover on page 261](#).
3. Remove the Cutter Door, see [Cutter Door F9A30-67006 on page 378](#).
4. Remove the Left Cover, see [Left Cover MFP SV Kit F9A30-67012 on page 268](#).
5. Remove the Right Cover, see [Right Cover MFP SV Kit F9A30-67011 on page 264](#).
6. Remove the Front Panel, see [Front Panel SFP F9A29-67008 on page 278](#).
7. Uncap the Carriage.

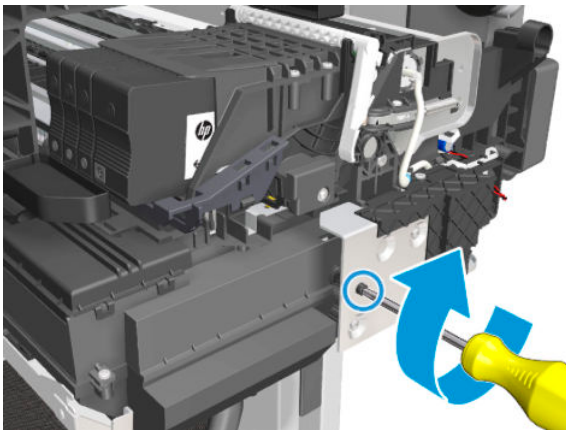



8. Move the Carriage to the left.

 **NOTE:** Image shown is from another product, and for reference only.

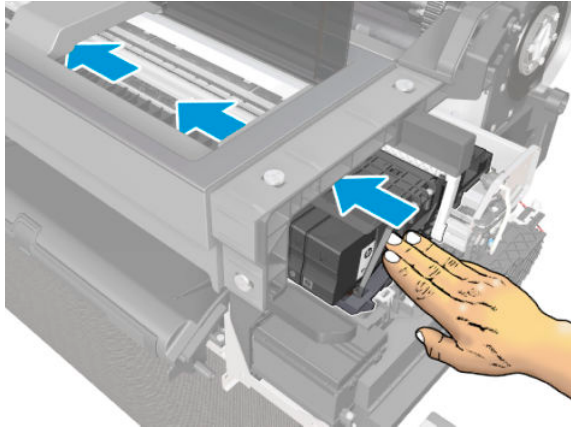

 **CAUTION:** Make sure the Carriage is positioned at the far left, so that the Trailing Cable does not become damaged.

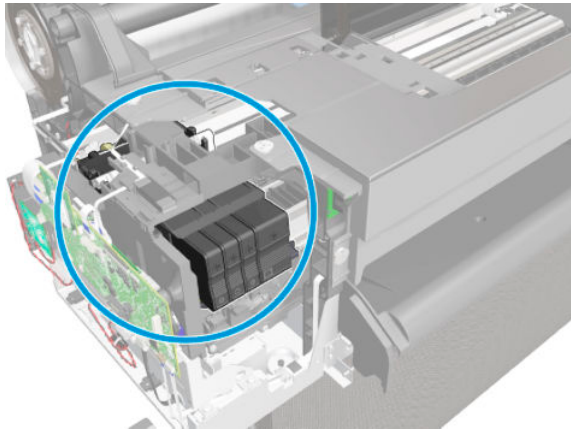

9. Close the Top Cover.



10. Ensure that the flat cable shown here is disconnected.

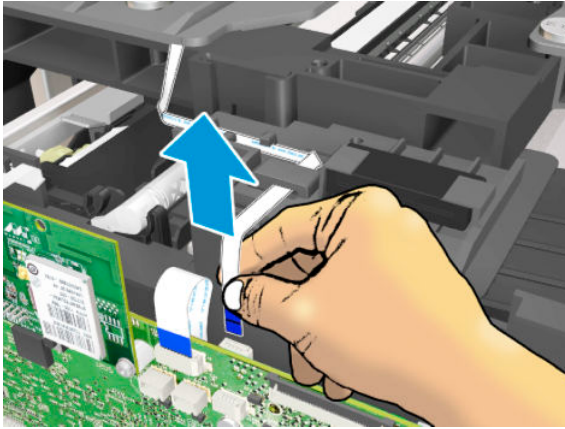

11. Unroute the flat cable.

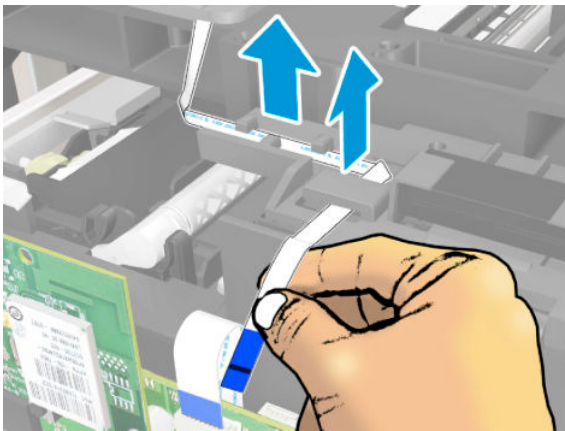

12. Remove two T-15 screws from the left side.

 **NOTE:** Image shown is from another product, and for reference only.

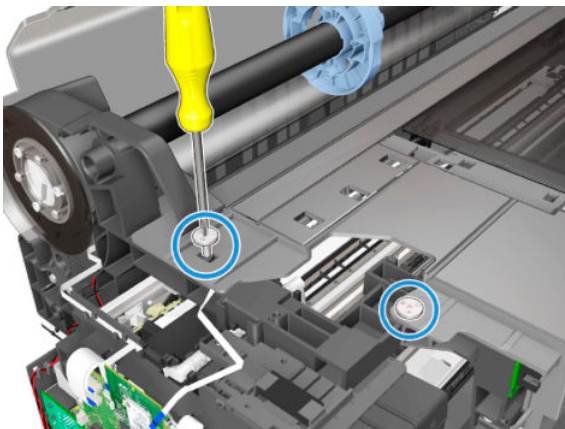

13. Remove two T-15 screws from the right side.

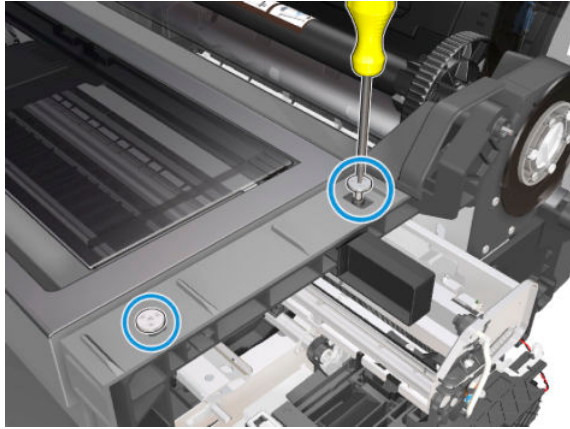

14. Remove one T-15 screw from the left side.

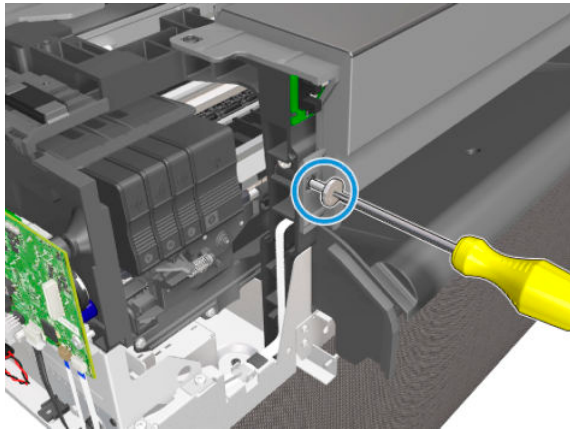

15. Unclip it from both sides.

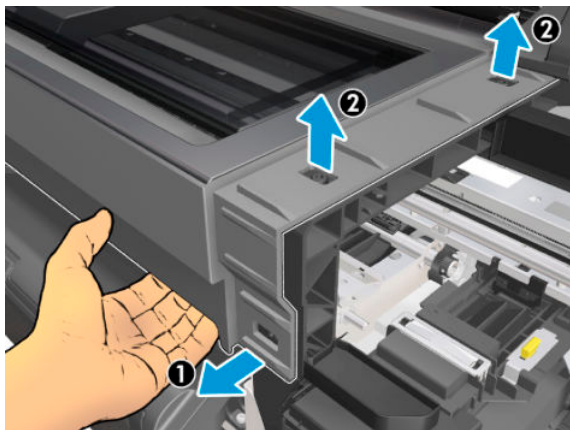

16. Remove the Central Cover.

 **NOTE:** Image shown is from another product, and for reference only.

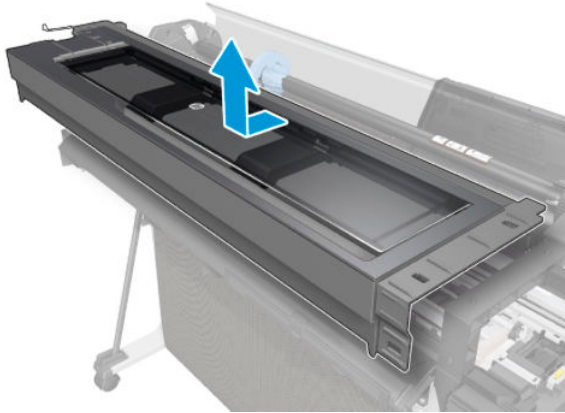

**Installation**

- ▲ **VERY IMPORTANT:** Before mounting the Central Cover by reversing the removal process, make sure that the Carriage is located at the extreme left.

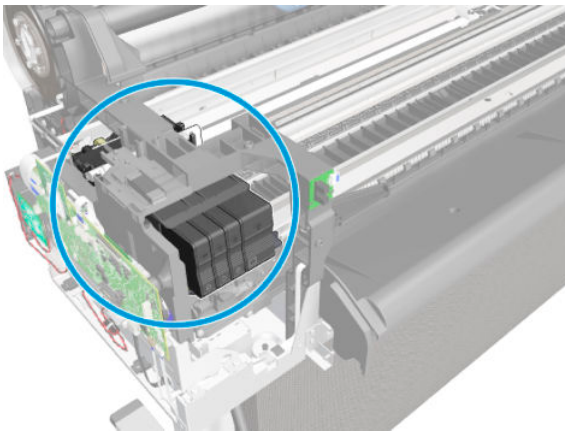

# Upper-Roll Paper Guide

## Removal

1. Switch off the printer and remove the power cable.
2. Remove the Back Cover, see [Back Cover on page 275](#).
3. Remove the Roll Cover, see [Roll Cover on page 272](#).
4. Remove the Spindle.
5. Remove two T-10 screws.



**NOTE:** The Multisheet Tray Sensor needs to be removed partially in order to access the screws. See [Multi-Sheet Tray Sensor Assembly on page 385](#).

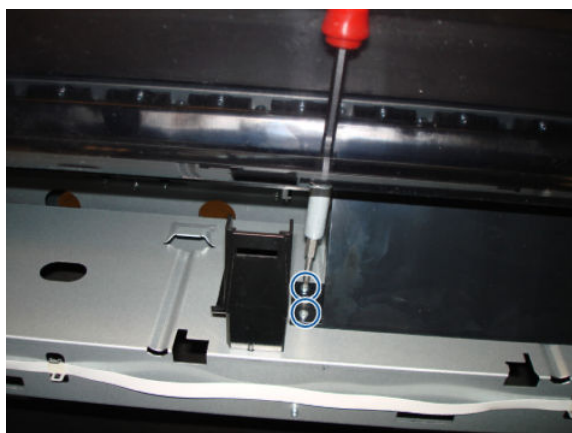

6. Remove two T-10 screws.



7. Move up the Upper-Roll Paper Guide to detach the pin.



8. Slide the Upper-Roll Paper Guide to the left to release both pins from the holes.

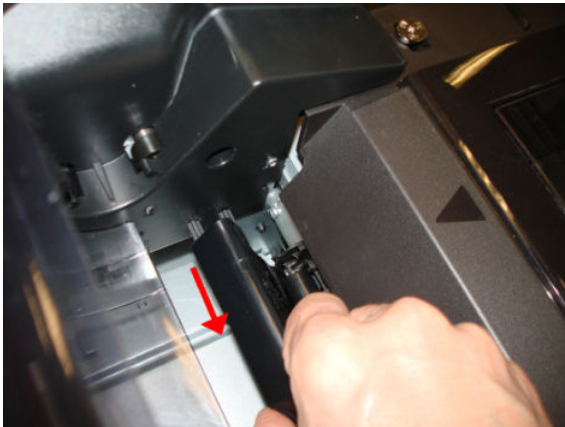

9. Close the Roll Cover.



10. Rotate up the Upper-Roll Paper Guide.



11. Rotate down the Upper-Roll Paper Guide.



12. Remove the Upper-Roll Paper Guide.

 **NOTE:** There are two brackets for the Back Cover that are screwed onto the Multi-Sheet Tray, which do not need to be removed.



## Installation

- ▲ The first step is to insert the two pins at the left, then install by reversing the removal process.

# Left Roll Support

## Removal

1. Switch off the printer and remove the power cable.
2. Remove the Front Cover, see [Front Cover on page 261](#).
3. Remove the Cutter Door, see [Cutter Door F9A30-67006 on page 378](#).
4. Remove the Left Cover, see [Left Cover MFP SV Kit F9A30-67012 on page 268](#).
5. Remove the Right Cover, see [Right Cover MFP SV Kit F9A30-67011 on page 264](#).
6. Remove the Back Cover, see [Back Cover on page 275](#).
7. Remove the Spindle.
8. Remove the Roll Cover, see [Roll Cover on page 272](#).
9. Remove the Upper-Roll Paper Guide, see [Upper-Roll Paper Guide on page 289](#).
10. Disconnect the flat cable.

 **NOTE:** Image shown is from another product, and for reference only.

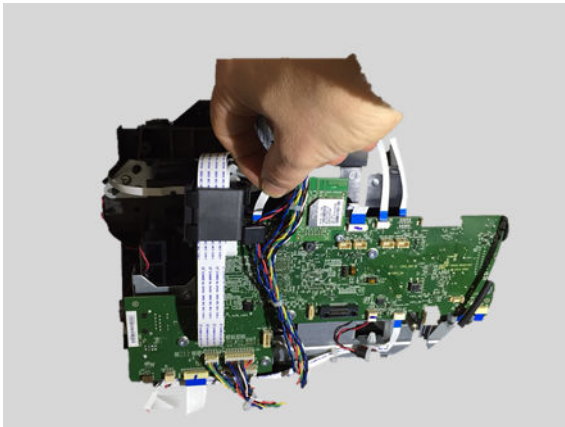

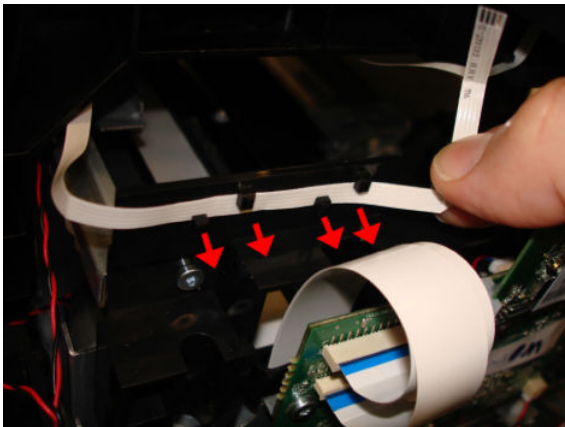

11. Detach the flat cable.





12. Disconnect the cable.

 **CAUTION:** Take care, because the small connector is easy to break.

 **NOTE:** Image shown is from another product, and for reference only.

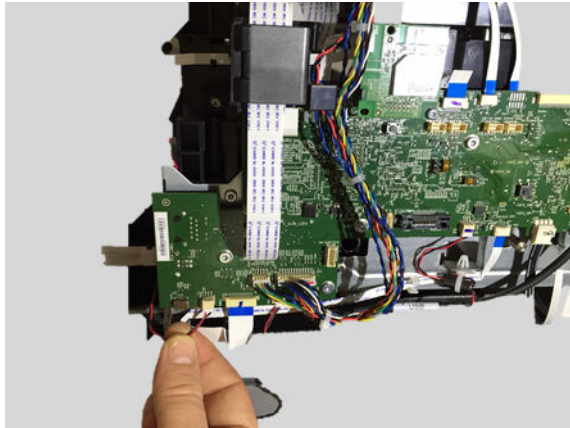

13. Detach the cable from the 3 clips of the LAN Panel USB.

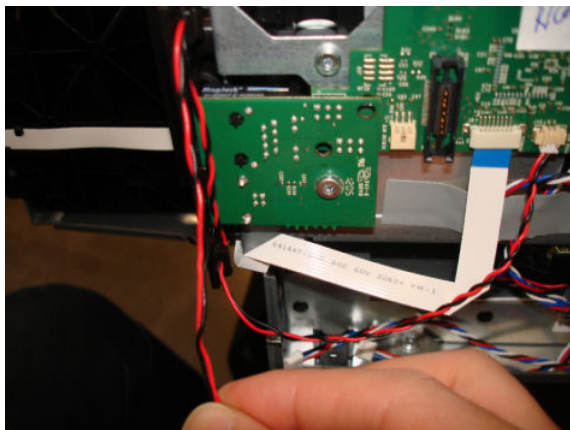

14. Make sure both cables are free.

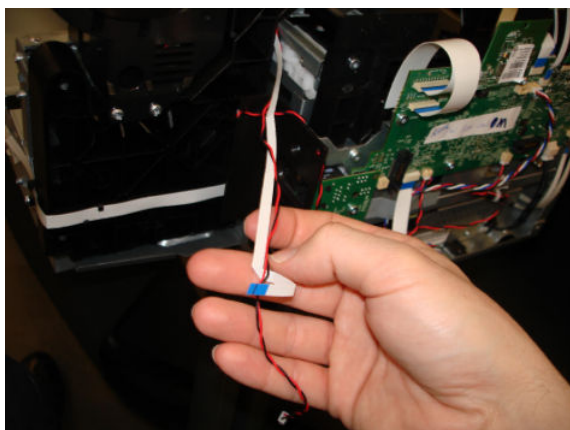

15. Remove three T-10 screws.



16. Remove two T-10 screws.

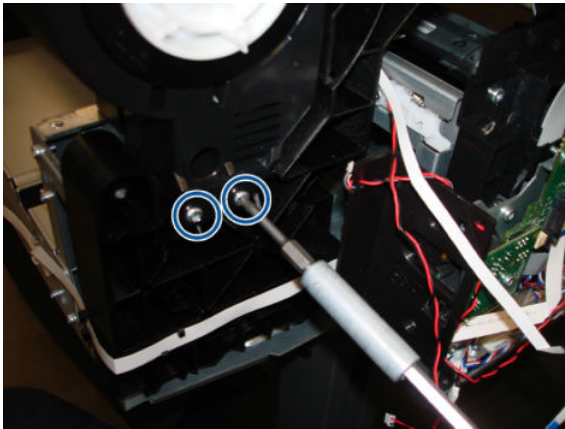

17. From the rear of the machine, rotate the Left Roll Support lower metal lugs a little to the right to detach them from the chassis bracket.

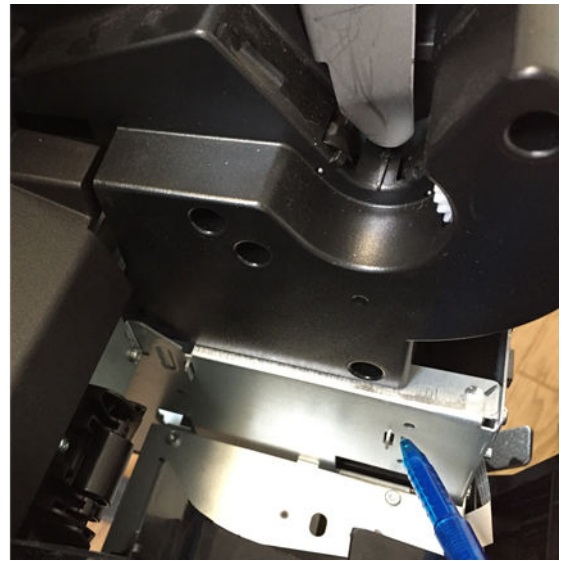
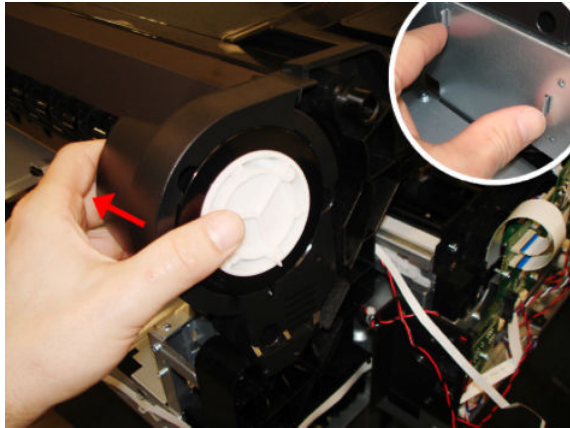

18. Remove the Left Roll Support, taking care not to damage the cables.

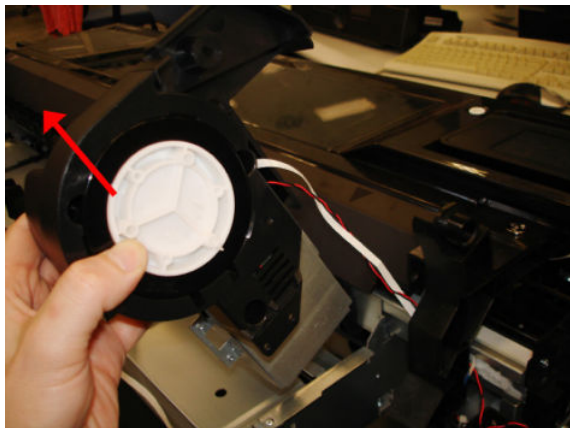

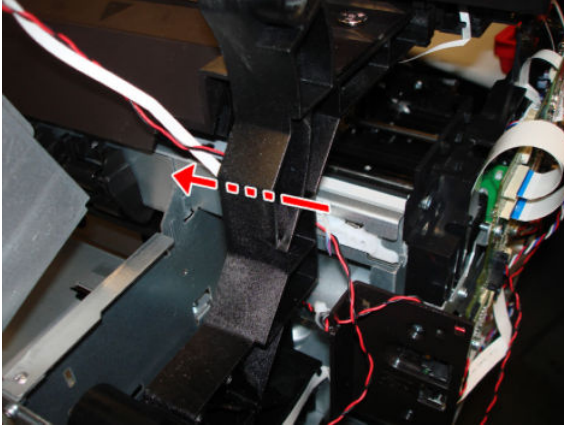

19. Pass the cables through the arch.

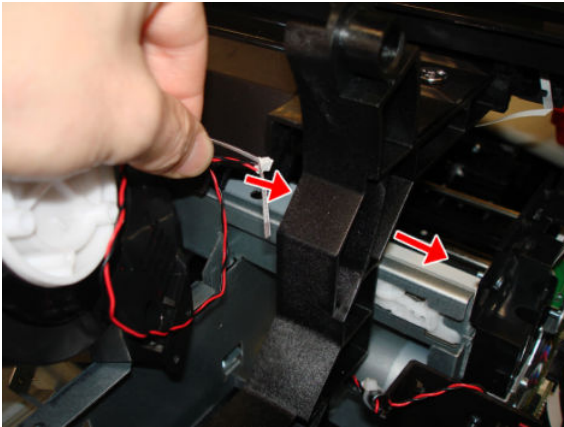

## Installation

1. When mounting the Left Roll Support, make sure to pass both cables through the arch.



 **NOTE:** Be careful with the routing, make sure it is the same as when the cables were removed. Check that it does not obstruct any moving parts or prevent any covers from being installed correctly.

2. Make sure the Left Roll Support is attached inside the two holes.

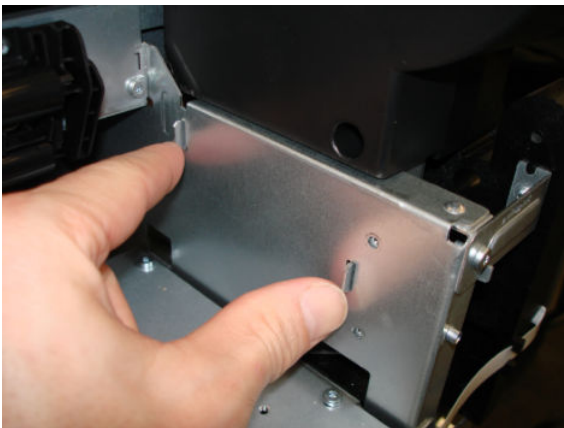

 **NOTE:** When connecting the cables to the Main PCA, make sure that the blue side of the flat cables is facing you; and, with the red/black cables, **the red color should always be on the left.**

# Right Roll Support

## Removal

1. Switch off the printer and remove the power cable.
2. Remove the Front Cover, see [Front Cover on page 261](#).
3. Remove the Cutter Door, see [Cutter Door F9A30-67006 on page 378](#).
4. Remove the Left Cover, see [Left Cover MFP SV Kit F9A30-67012 on page 268](#).
5. Remove the Right Cover, see [Right Cover MFP SV Kit F9A30-67011 on page 264](#).
6. Remove the Back Cover, see [Back Cover on page 275](#).
7. Remove the Spindle.
8. Remove the Roll Cover, see [Roll Cover on page 272](#).
9. Remove the Upper-Roll Paper Guide, see [Upper-Roll Paper Guide on page 289](#).

 **NOTE:** There are two brackets for the back cover that are screwed onto the Multi-Sheet Tray, these do not need to be removed.

---

10. Remove three T-15 screws.

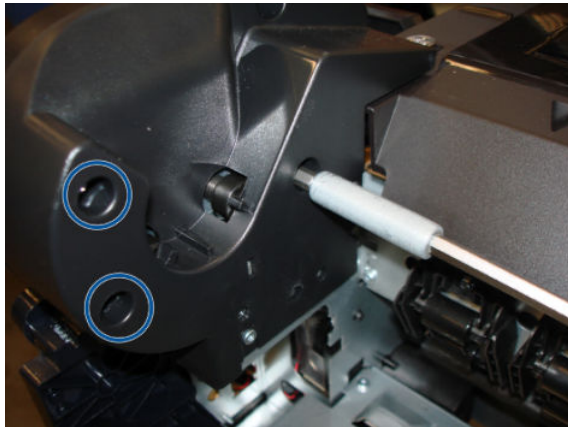

11. Remove two T-10 screws.

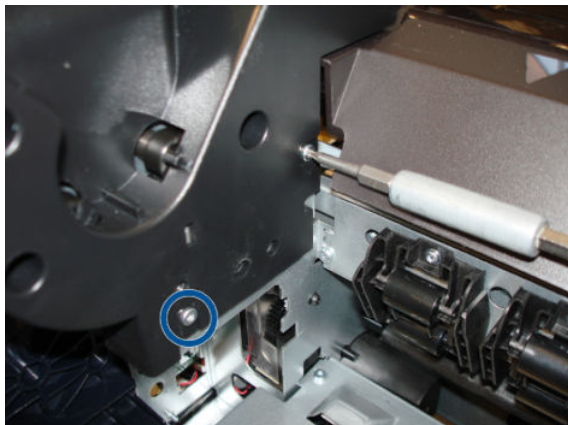

12. Remove three T-10 screws.

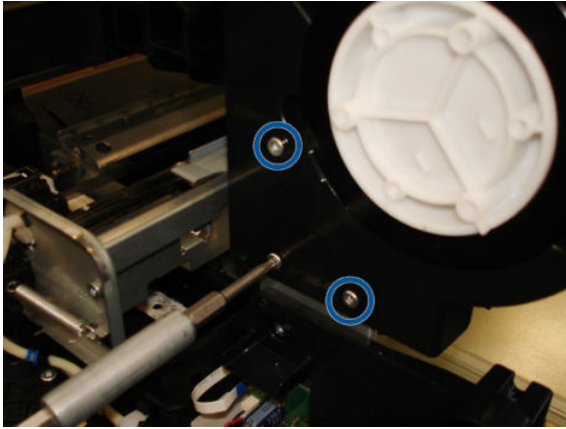

13. Remove the end of the Roll Support.

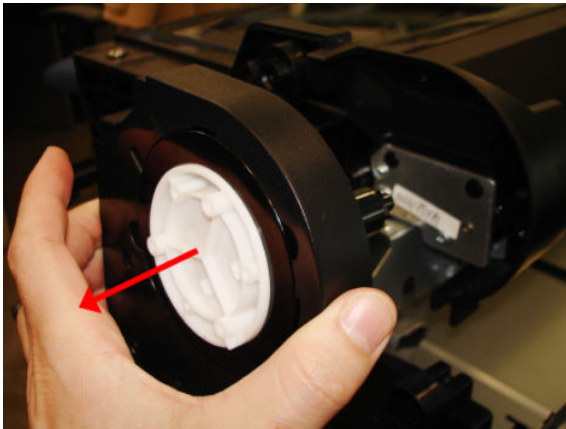

14. Remove one T-10 screw.



15. Remove the Cover Right Roll Support.

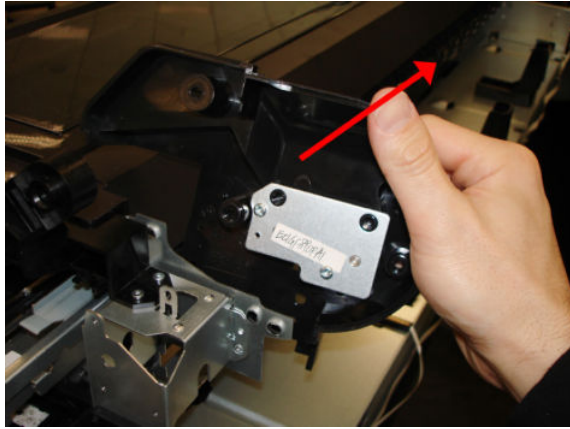

### Installation

- ▲ Install the Right Roll Support by reversing the removal process.

# Encoder Strip

## Removal

1. Switch off the printer and remove the power cable.
2. Remove the Front Cover, see [Front Cover on page 261](#).
3. Remove the Right Cover, see [Right Cover MFP SV Kit F9A30-67011 on page 264](#).

 **NOTE:** **MFP only:** Scanner removal is recommended before proceeding further. See [Scanner Module on page 505](#).

4. Uncap the Carriage and move it to the left.

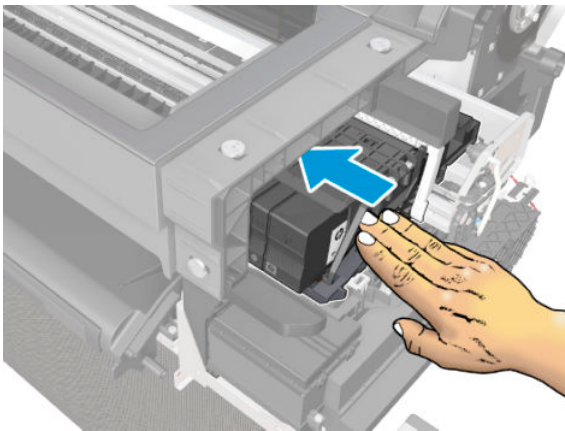

5. Insert some paper (of any type) to prevent grease or dirt from falling into the printer.

 **NOTE:** When working in this area, in which dirt and grease can contaminate other parts of the printer, we recommend wearing gloves.

 **NOTE:** Image shown is from another product, and for reference only.

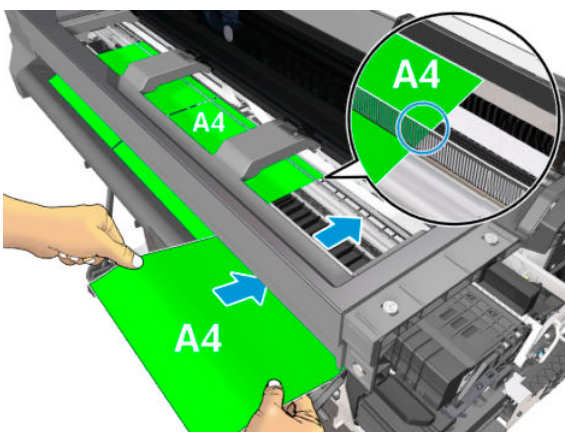



6. Detach the spring.

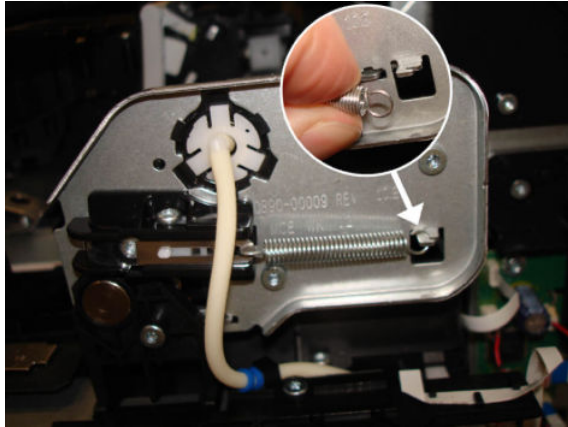

**⚠ CAUTION:** The Encoder Strip must not come into contact with the slider rod grease! Handle with care, and be careful with your hands and the Encoder Strip.

**CAUTION:** The primer pipe at the end plate can become damaged.

7. Remove one screw.

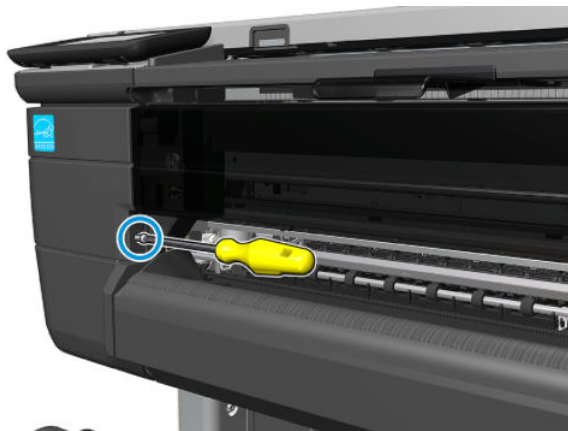

8. Open the Cutter Door.



9. Rotate the Encoder Strip a little to detach it from the hook.

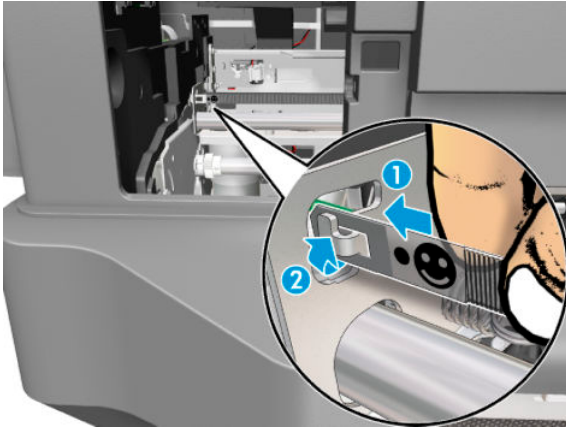

10. Detach the Encoder Strip from the hook.

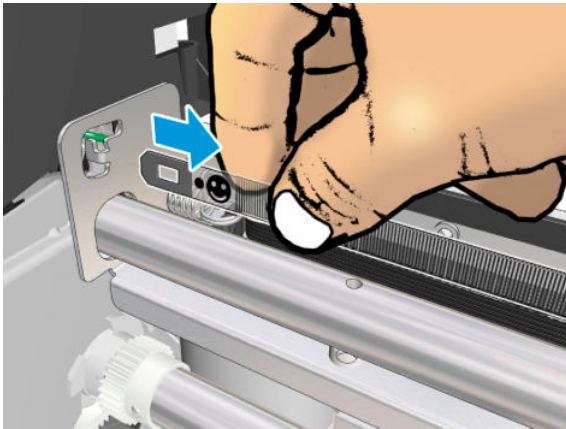

11. Slide the Encoder Strip carefully from the right side, and remove it.

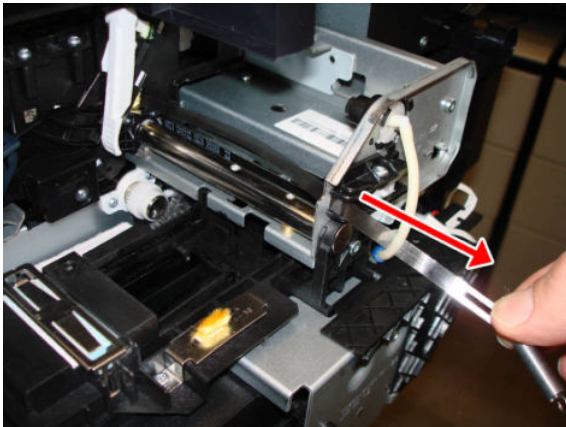

## Installation

1. Move the Carriage to cap position.

2. Pass the Encoder Strip through the hole of the bracket. **Very important:** The face is shown here:

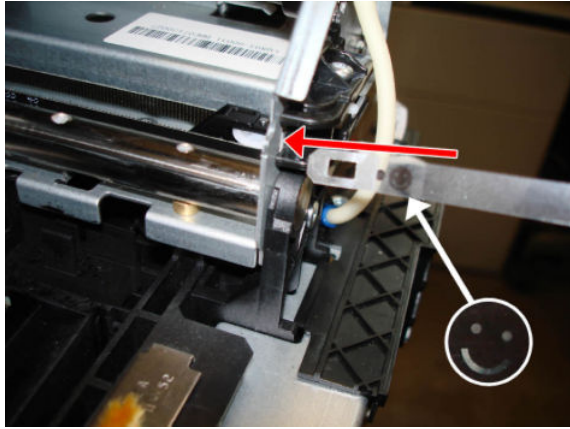

 **NOTE:** The Encoder Strip must be inserted from the right side of the Carriage into the left side.

3. Pass the Encoder Strip through the hole of the Carriage, taking care not to bend it.

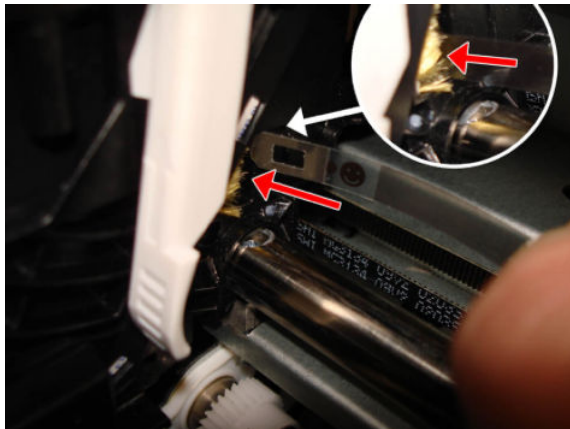

4. The Encoder Strip should go out through the other side of the Carriage as shown.

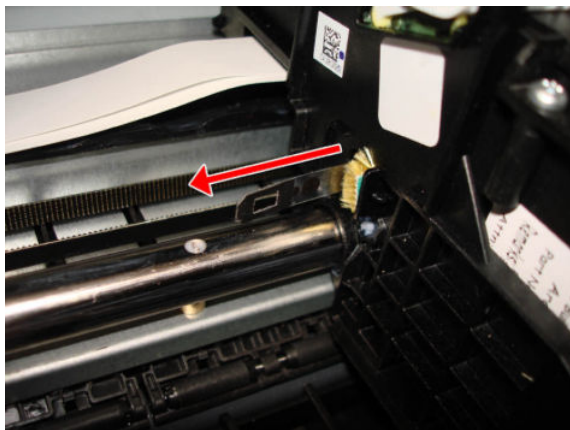

5. The right end of the Encoder Strip must have the triangle in the position as shown below.

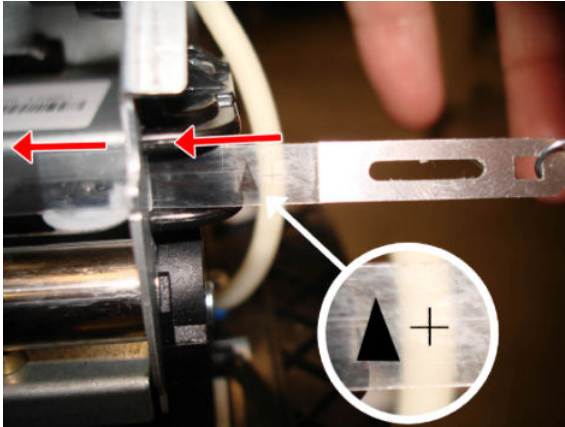

6. When you attach the left end of the Encoder Strip to the hook, make sure the position of the face is as shown below.

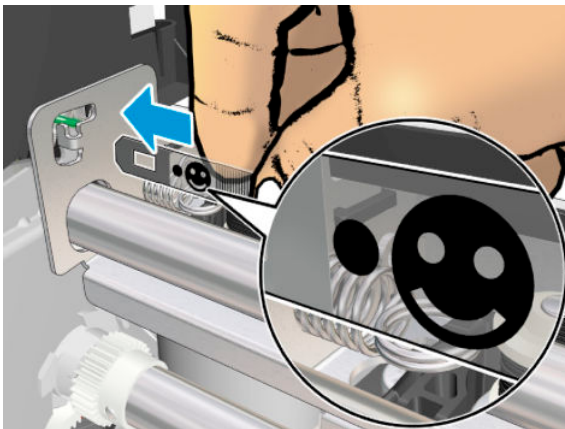

7. Attach the Encoder Strip at the left before attaching the spring at the right.

# Printer NVM backup PCA

## Removal of the NVM PCA

1. Switch off the printer and remove the power cable.
2. Remove the Front Cover, see [Front Cover on page 261](#).
3. Remove the Cutter Door, see [Cutter Door F9A30-67006 on page 378](#).
4. Remove the Left Cover, see [Left Cover MFP SV Kit F9A30-67012 on page 268](#).
5. Disconnect the flat cable.

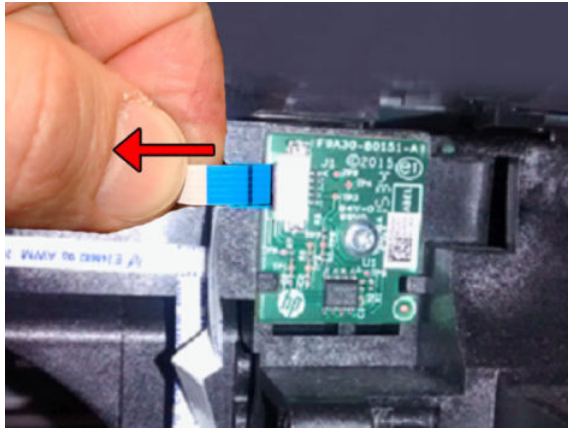

6. Remove one T-10 screw.
7. Remove the PCA.

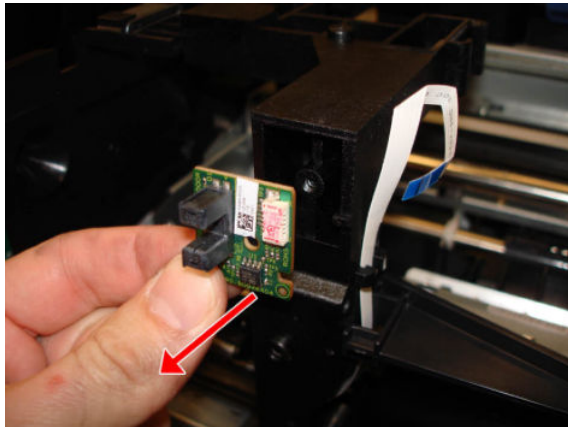

## Removal of Printer Back Up NVM PCA

The cable needs to be replaced only if it is clearly damaged or if the replaced sensor fails to work.

1. Slide down the flat cable to detach it from the hook.

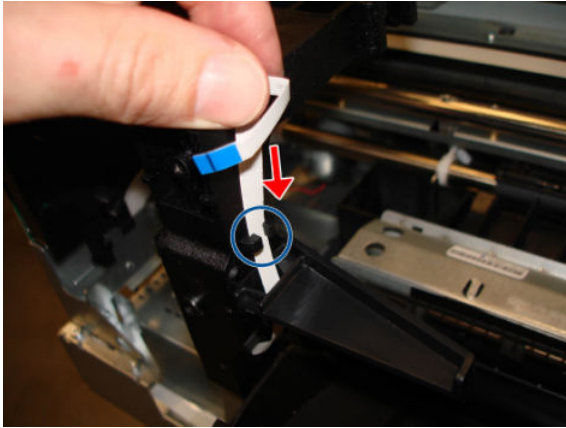

2. Unroute the Printer Back Up NVM PCA Cable.
3. Be sure the PCA Cable is free as shown.

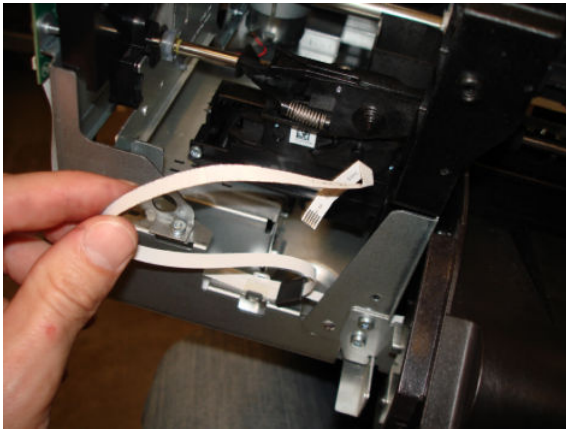

4. Unclip the PCA Cable from the clip.

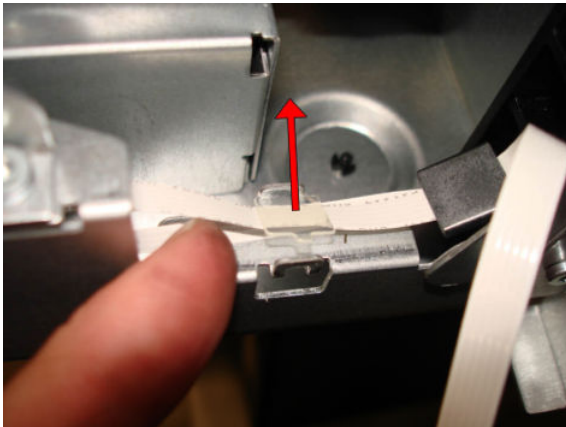

5. Slide out the PCA Cable, taking care not to lose the ferrite.

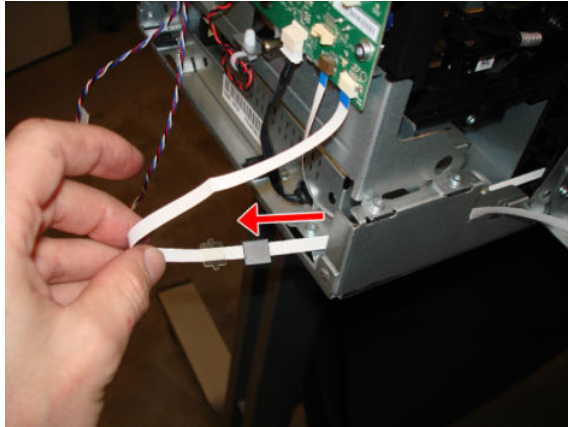

6. Disconnect the PCA Cable.

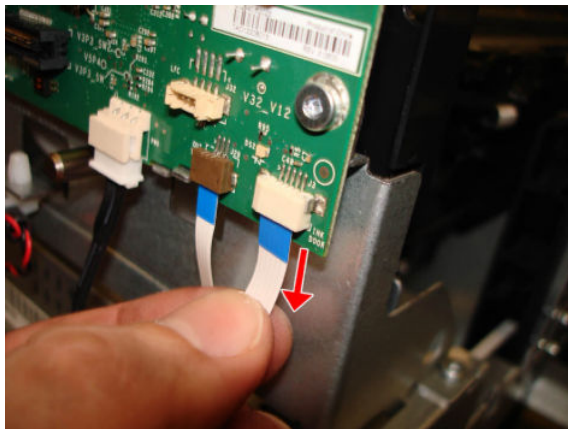

7. Remove the Printer Back Up NVM PCA Cable.

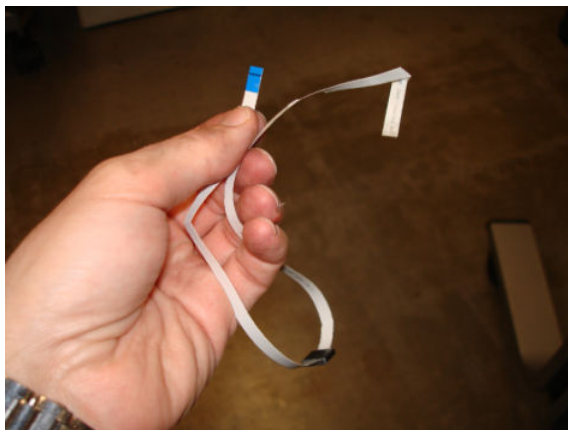

### Installation of the Printer Back Up NVM PCA Cable

- ▲ It is important to route the new cable in the same way as the old cable.

# Power Supply

## Removal

1. Switch off the printer and remove the power cable.
2. Remove the Front Cover, see [Front Cover on page 261](#).
3. Remove the Cutter Door, see [Cutter Door F9A30-67006 on page 378](#).
4. Remove the Left Cover, see [Left Cover MFP SV Kit F9A30-67012 on page 268](#).
5. Disconnect the Power Supply cable from the Main PCA.

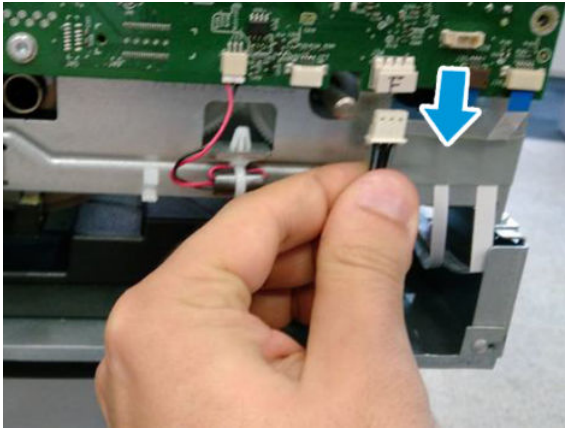

6. Remove two T-10 screws.

 **NOTE:** Image shown is from another product, and for reference only.

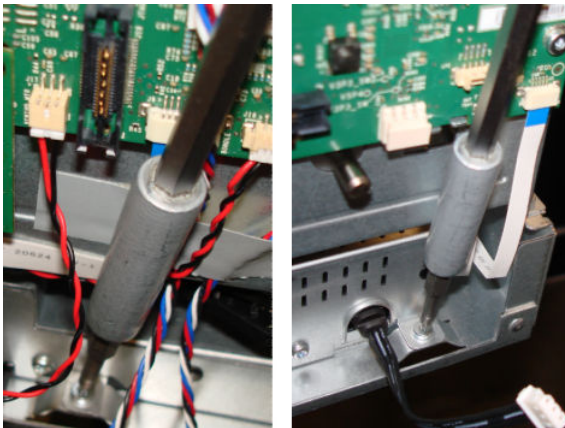



7. Slide out with a flat screwdriver and push from the rear.

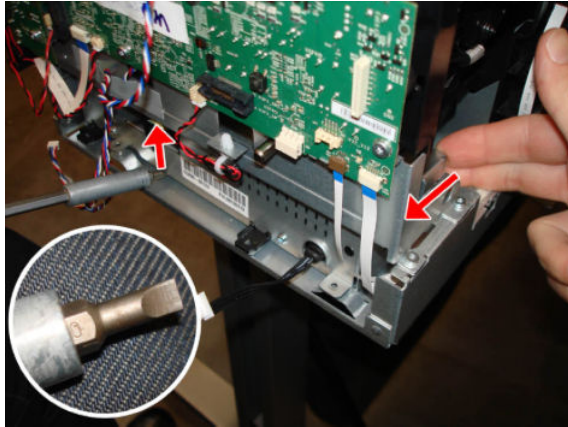

8. Never take out the Power Supply by pulling the cable, because you will damage it.

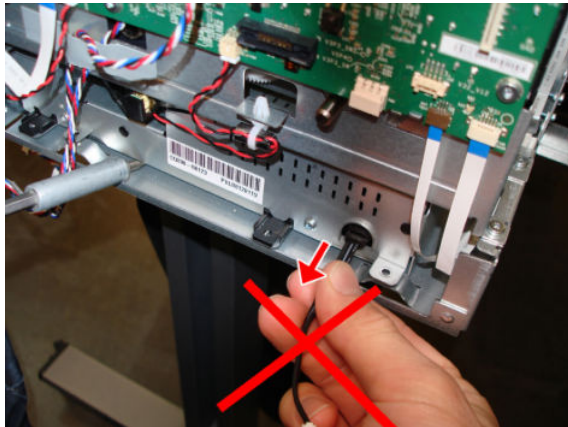

9. Slide out the Power Supply carefully.

**CAUTION:** Take care not to disconnect or damage any cables or the Disk Encoder.

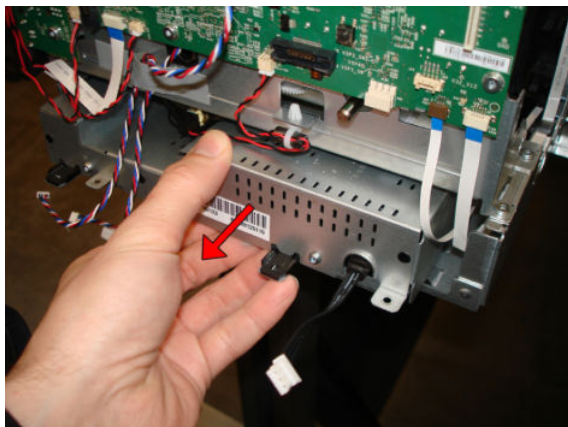

10. Remove the Power Supply from the front.

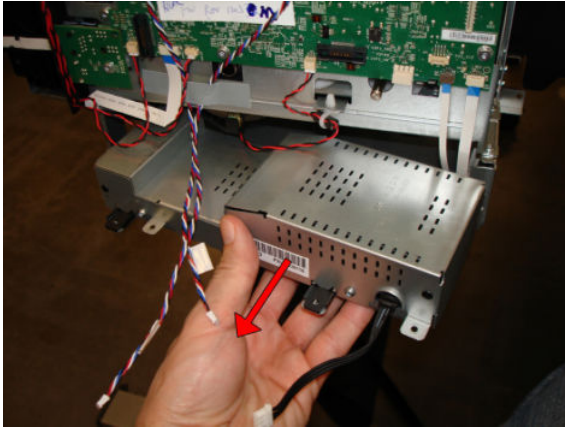

### Installation

- ▲ Install the Power Supply by reversing the removal process.

# Main PCA

## Removal

1. Switch off the printer and remove the power cable.
2. Remove the Front Cover, see [Front Cover on page 261](#).
3. Remove the Cutter Door, see [Cutter Door F9A30-67006 on page 378](#).
4. Remove the Left Cover, see [Left Cover MFP SV Kit F9A30-67012 on page 268](#).
5. Disconnect all cables (**T730**: 7 FFC cables on top, 4FFC cables underneath, and 3 motor cables. **T830**: MFP: Scanner FFC 3 cables on top, 7 FFC cables on top, 4FFC cables underneath, and 5 motor cables). See [The Main PCA on page 42](#).

---

**⚠ CAUTION:** Take care! Do not pull up so hard as to damage the connectors .

---

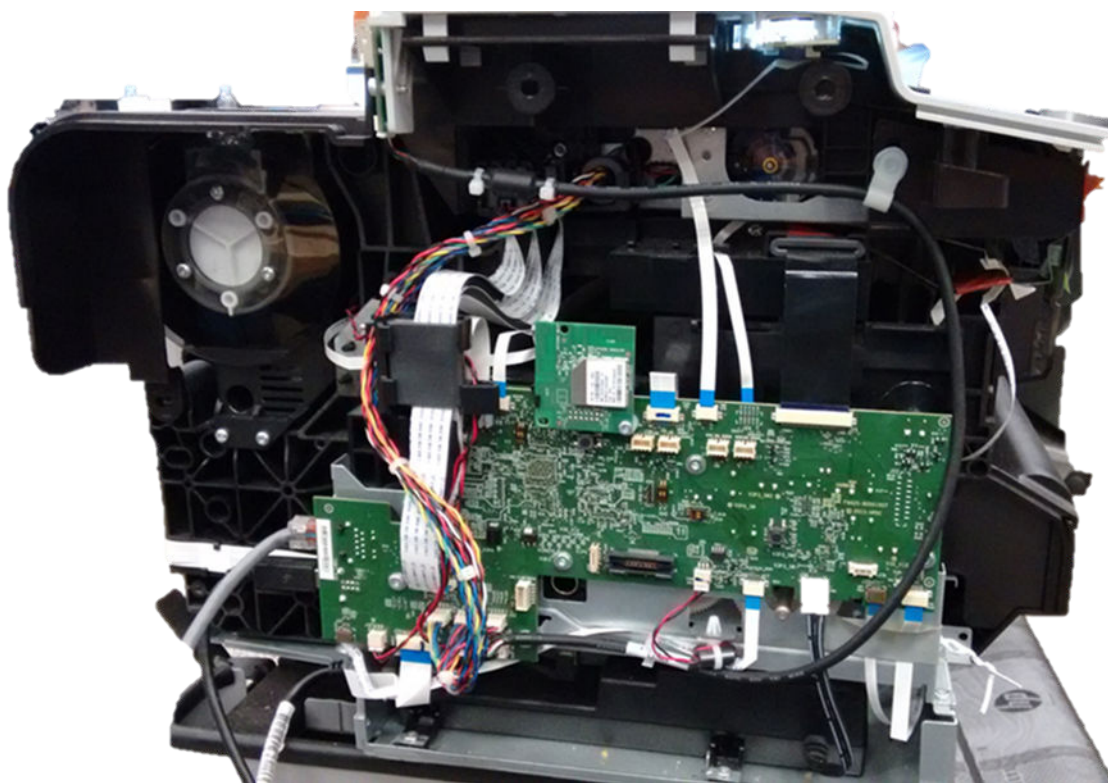

6. Disconnect the flat cable.

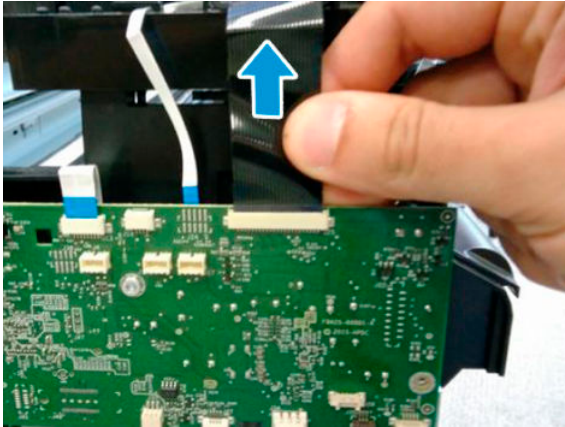

7. Unclip and remove it.

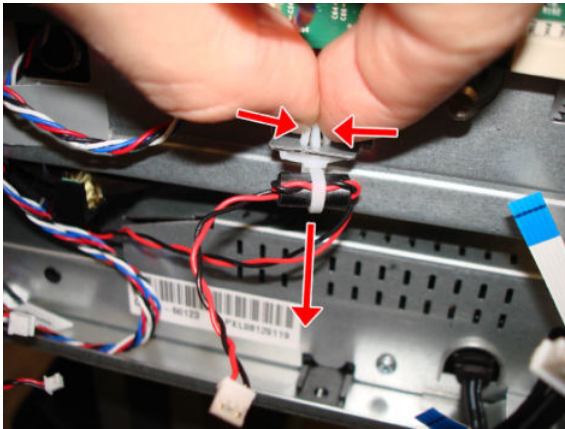

8. Unhook the two cables from the bottom hook.

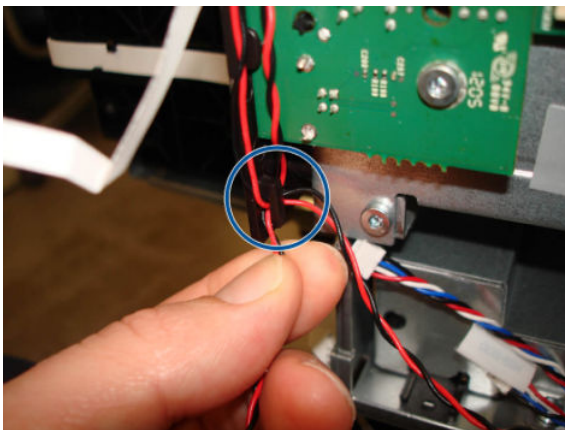

9. Unhook the two cables from the top hooks.

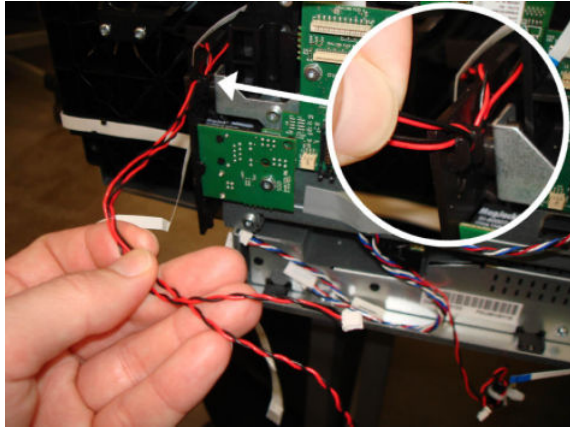

10. Make sure both cables are free.

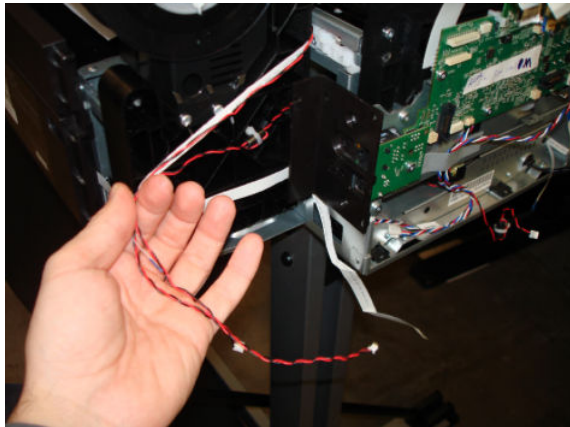

11. Remove two T-10 screws.

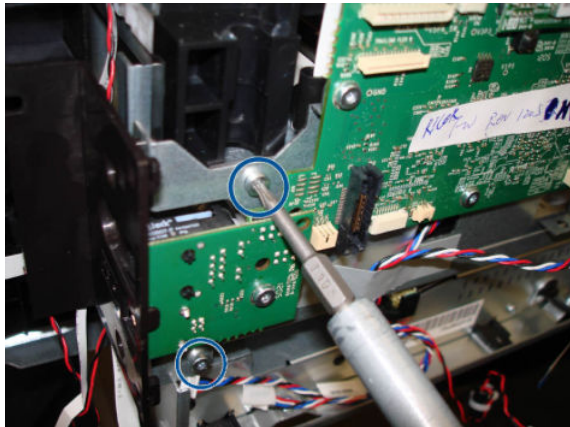

12. Remove two T-10 screws.

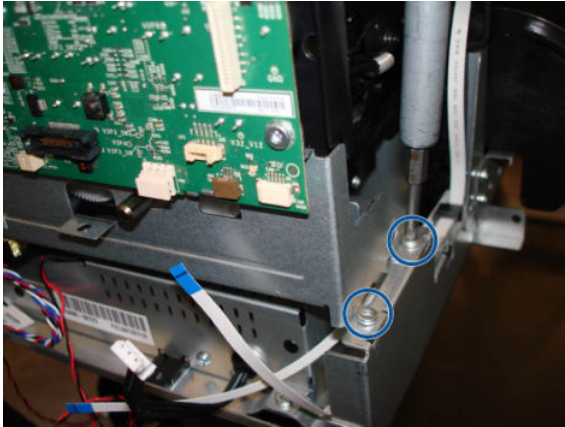

13. Slide out the Main PCA horizontally to disengage it from the hook.

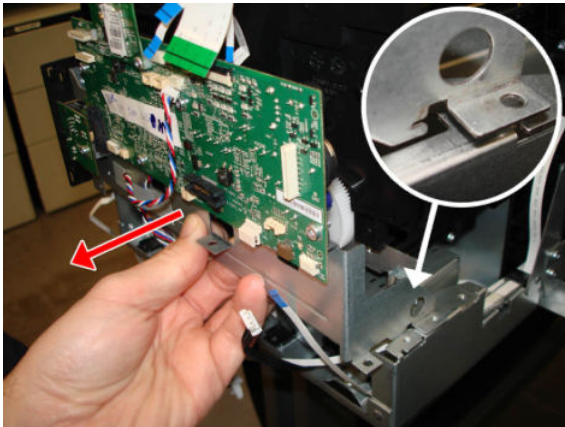

14. Remove the Main PCA.

**⚠ CAUTION:** The Main PCA will come out of the printer together with the attached metal bracket.

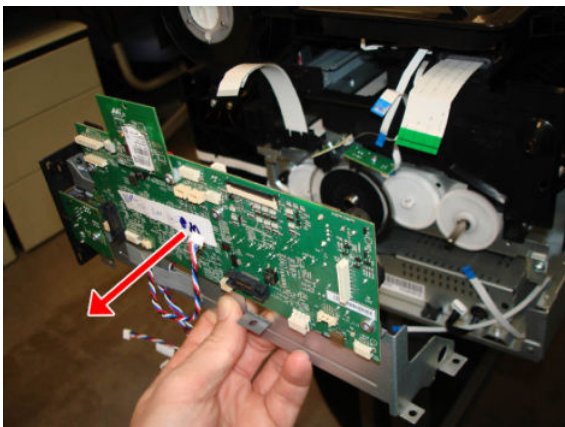

## Installation

1. When mounting the Main PCA, remember to insert it in the hook.

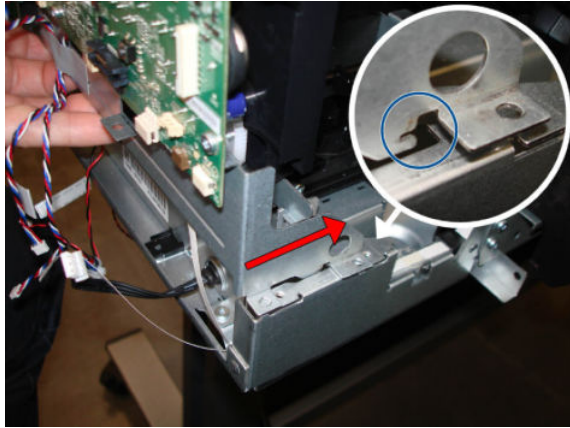

2. First place these two screws, because will be easier to screw in the next two screws.

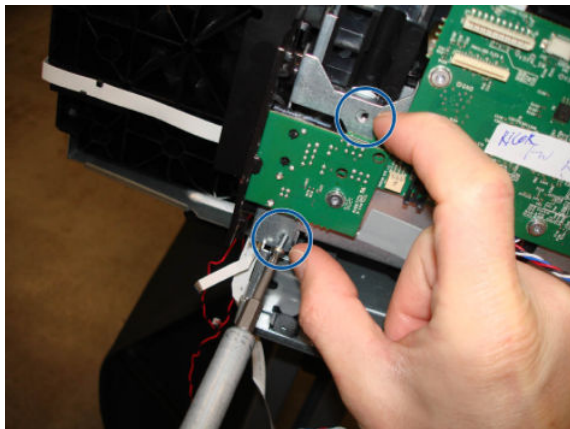

3. Push in the bracket of the Main PCA to align the two holes and screw the two screws without damaging them.

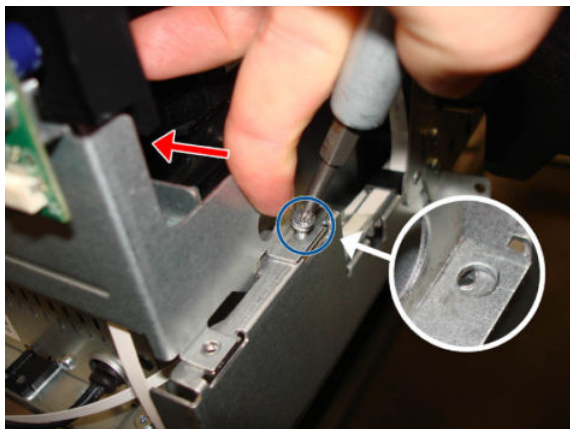

4. When connecting the cables to the Main PCA, make sure that the blue side of the flat cables is facing you; and, with the red/black cables, **the red color should always be on the left**.

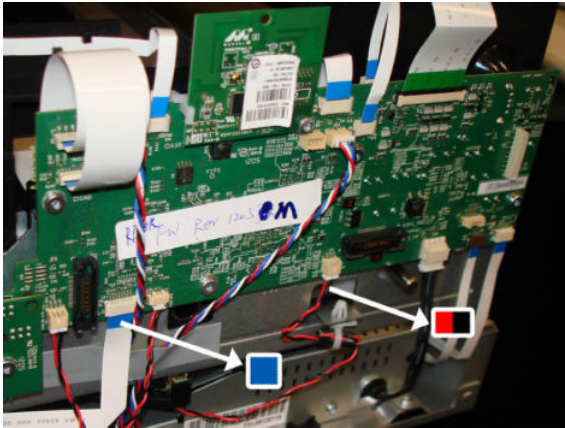

**IMPORTANT:** MFP only: Synchronize the Main PCA and Scan Bundle Board after Main PCA replacement:  
**Extended Support Menu -> "Scanner save calibrations"**.



# Paper Motor

## Removal

1. Switch off the printer and remove the power cable.
2. Remove the Front Cover, [Front Cover on page 261](#).
3. Remove the Cutter Door, see [Cutter Door F9A30-67006 on page 378](#).
4. Remove the Left Cover, see [Left Cover MFP SV Kit F9A30-67012 on page 268](#).
5. Remove the Main PCA, see [Main PCA on page 311](#).
6. Remove two T-10 screws.

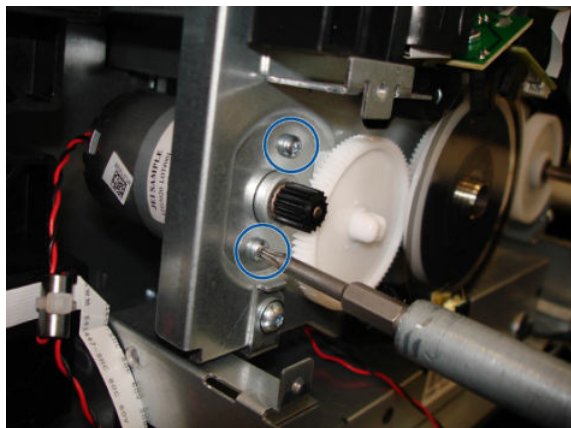

7. Slide the Paper Motor inwards, and hold it with a finger to stop it falling down.

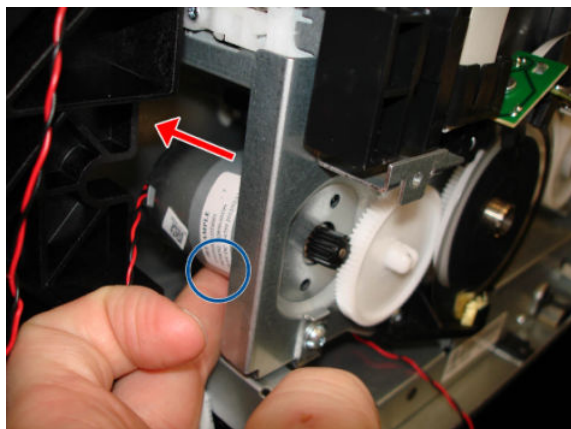

8. Slide it out from this hole.

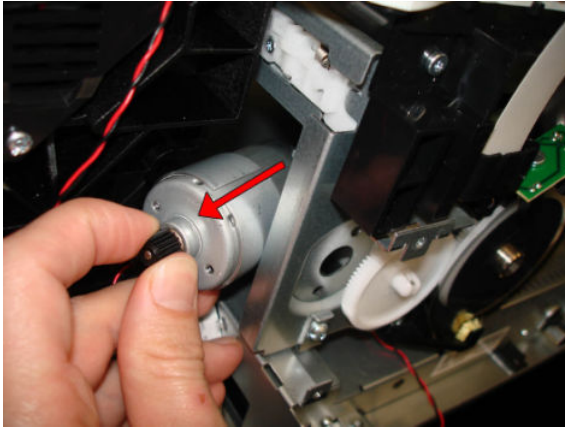

9. Remove the Paper Motor.



## Installation

- ▲ Make sure to reinstall the ferrite inside the wall of the LAN Panel USB.

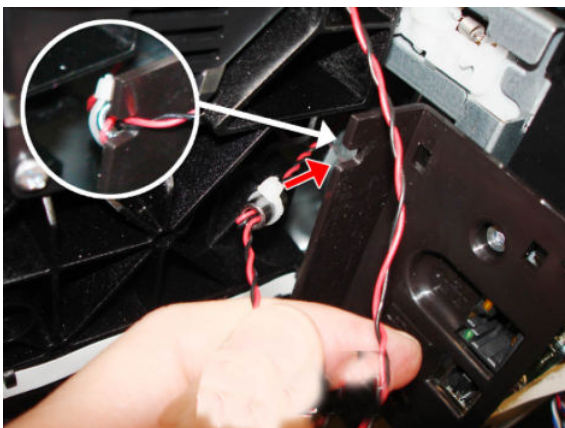

# Encoder PCA and Index

## Removal

1. Switch off the printer and remove the power cable.
2. Remove the Front Cover, see [Front Cover on page 261](#).
3. Remove the Cutter Door, see [Cutter Door F9A30-67006 on page 378](#).
4. Remove the Left Cover, see [Left Cover MFP SV Kit F9A30-67012 on page 268](#).
5. Remove the Main PCA, see [Main PCA on page 311](#).
6. Remove one T-10 screw.

---

 **CAUTION:** Be careful not to damage the Encoder Disk.

---

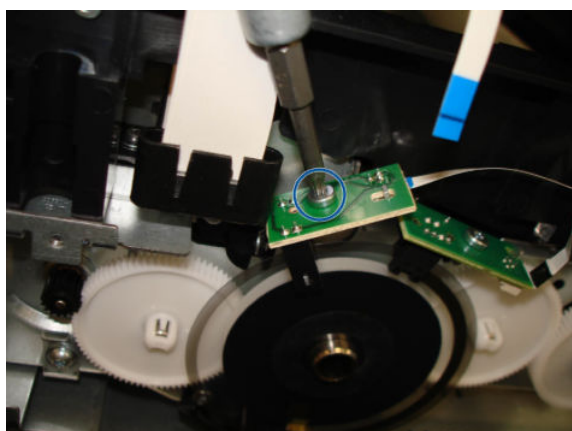

7. Release the PCA from the pin or locator.

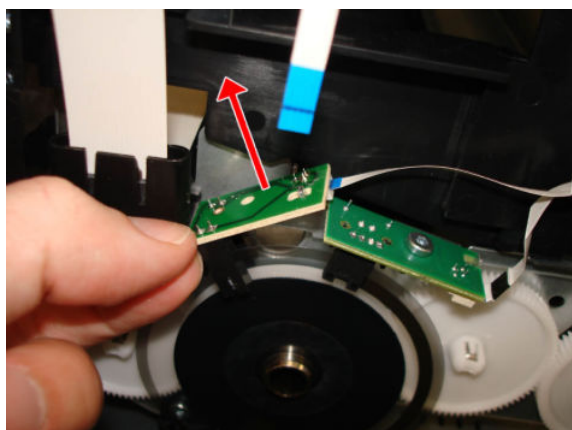

8. Rotate the PCA to see the connector.

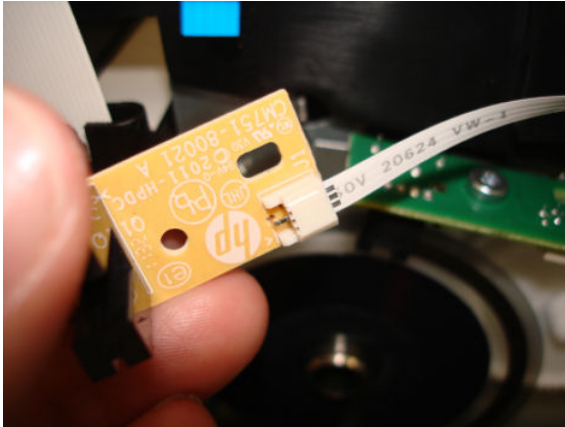

9. Disconnect the flat cable.

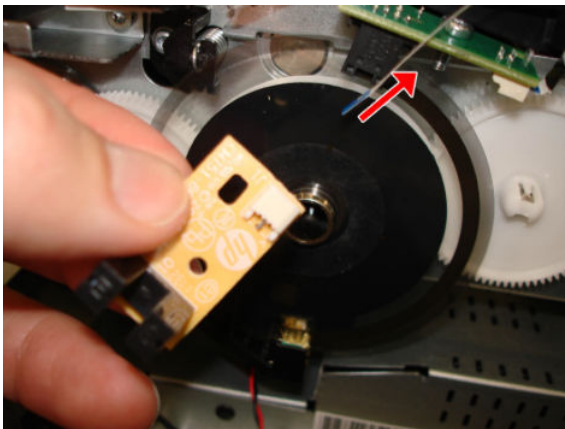

10. Remove one T-10 screw.

**⚠ CAUTION:** Be careful not to damage the Encoder Disk.

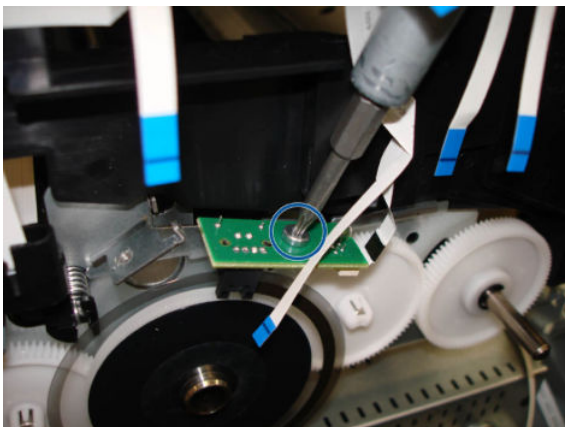

11. Release the PCA from the pin or locator.

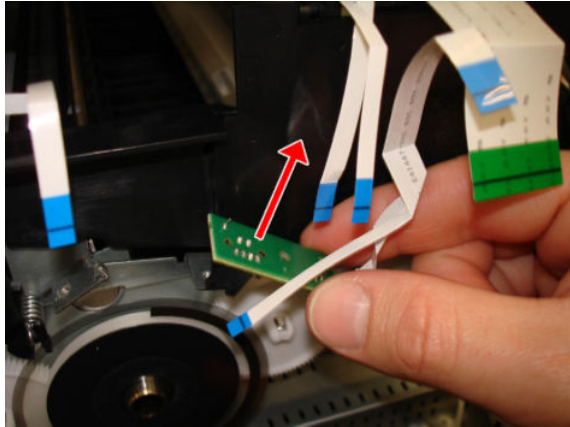

12. Rotate the PCA to see the connector.

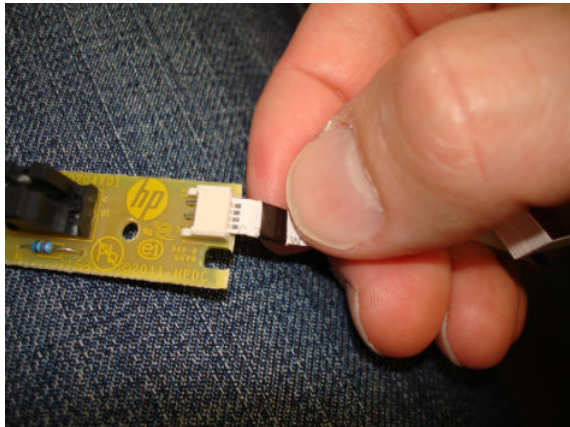

13. Disconnect the flat cable.

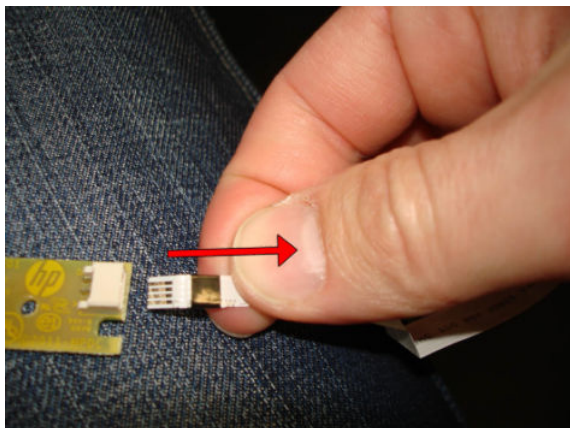

## Installation

1. Be careful not to damage the Encoder Strip when you mount the two PCAs.

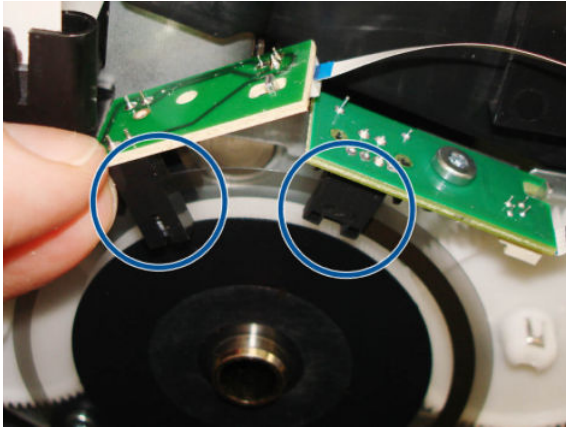

2. When connecting the cables to the PCAs, make sure that the blue side of the flat cables is facing up.

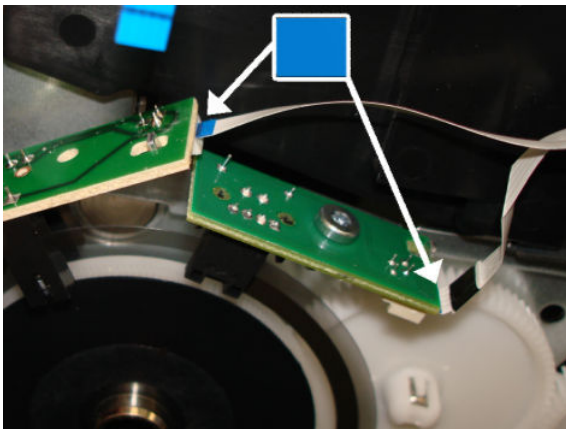

## Encoder Disk

1. Switch off the printer and remove the power cable.
2. Remove the Front Cover, see [Front Cover on page 261](#).
3. Remove the Cutter Door, see [Cutter Door F9A30-67006 on page 378](#).
4. Remove the Left Cover, see [Left Cover MFP SV Kit F9A30-67012 on page 268](#).
5. Remove the Main PCA, see [Main PCA on page 311](#).
6. Remove the Encoder PCA and Index, see [Encoder PCA and Index on page 319](#).
7. Remove one T-10 screw.

 **NOTE:** Image shown is from another product, and for reference only.

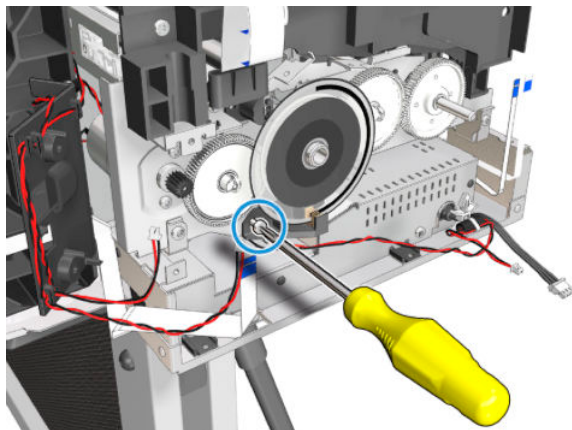

8. Remove the Holder Brush Feed Shaft.

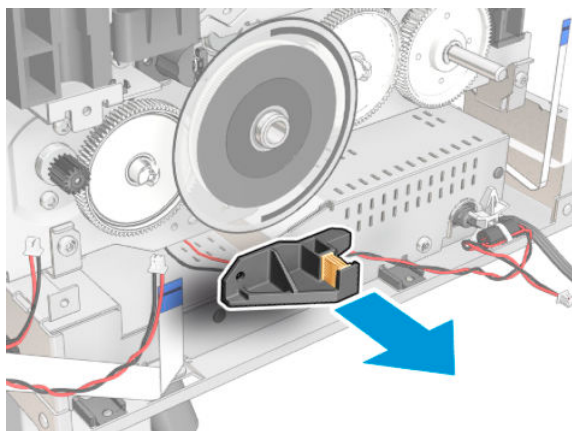

9. **IMPORTANT:** Do not remove the Encoder Disk without checking the position of the black reference mark.

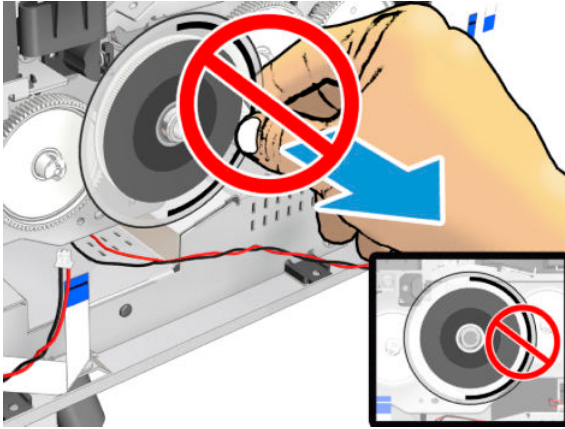

10. Rotate the Encoder Disk to a position where the black reference mark is entirely below the midpoint of the disk (so that it looks like a smile).

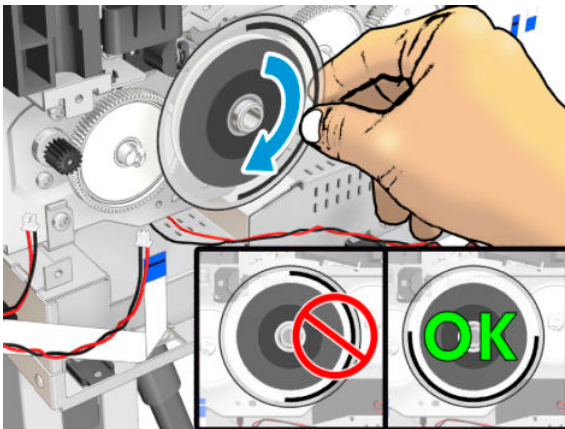

11. Remove the Encoder Disk by pulling it off (without moving the Roller).

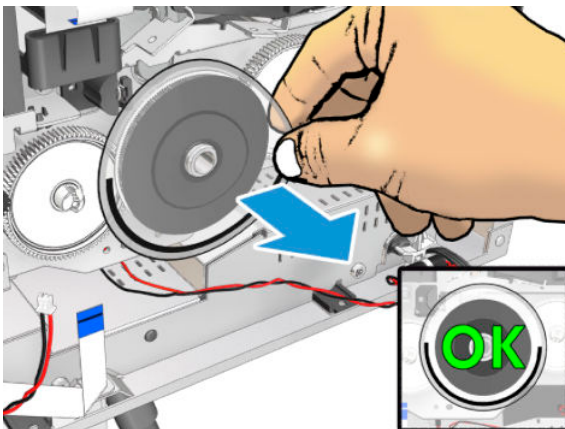

## Installation

1. Remove the film from the new Encoder Disk. **IMPORTANT:** Wear gloves.



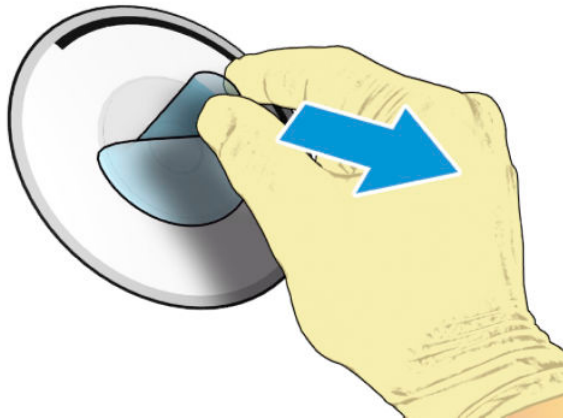

2. Clean the new Encoder Disk with a lint-free cloth dampened with alcohol to remove any remaining glue. Let it dry before proceeding.
3. Attach the new Encoder Disk with the black reference mark in exactly the same position as it was when you removed it (without moving the Roller).

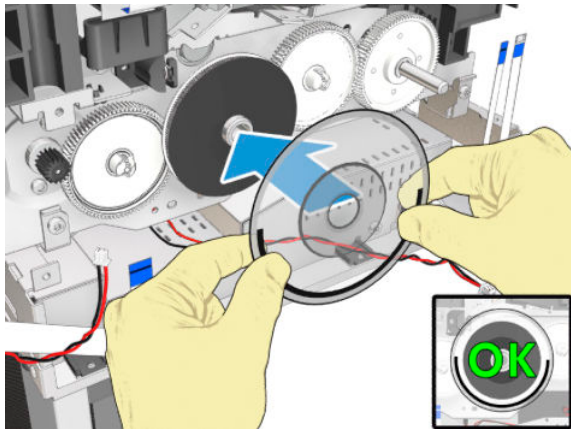

4. Make sure the Encoder Disk is firmly attached.

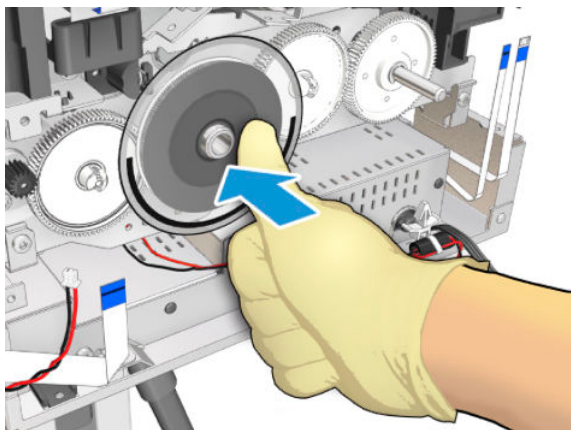

# Trailing Cable

## Removal

1. Switch off the printer and remove the power cable.
2. **(MFP only)** Remove the Scanner Module, see [Scanner Module on page 505](#).
3. Remove the Front Cover, see [Front Cover on page 261](#).
4. Remove the Cutter Door, see [Cutter Door F9A30-67006 on page 378](#).
5. Remove the Left Cover, see [Left Cover MFP SV Kit F9A30-67012 on page 268](#).
6. Remove the Right Cover, see [Right Cover MFP SV Kit F9A30-67011 on page 264](#).
7. Remove the Front Panel, see [Front Panel SFP F9A29-67008 on page 278](#).

 **TIP:** If you want to power on the printer, the Front Panel can be placed on clips (without cover).

8. Remove Central Cover, see [Central Cover on page 284](#).
9. Move the Carriage to the middle of the Platen.

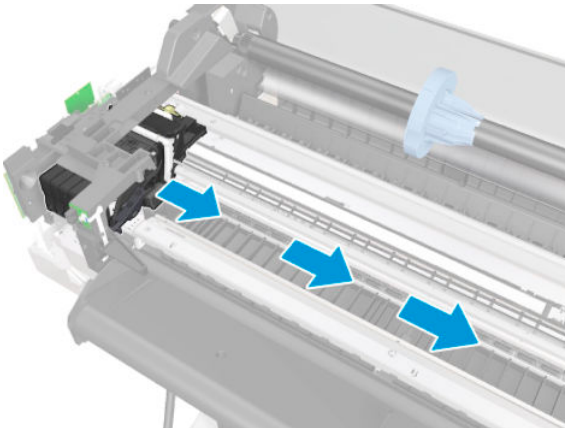

10. Remove the PCA Carriage Cover.

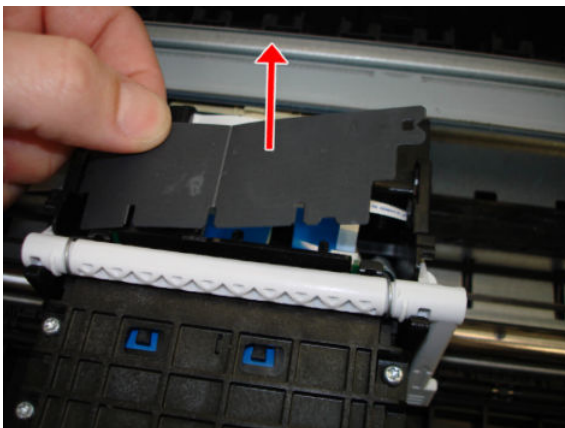

11. Unclip and remove the strain relief.

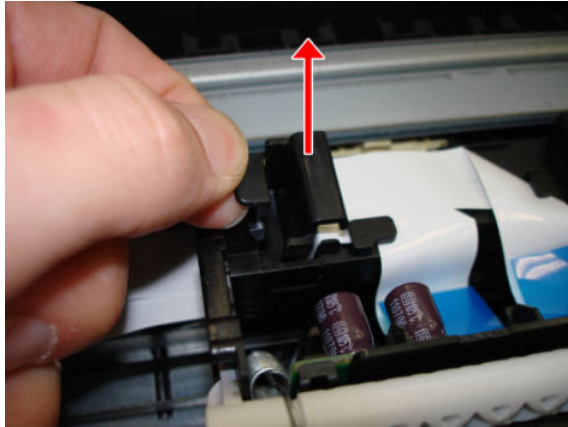

12. Disconnect the Trailing Cable by pulling the blue plastic.

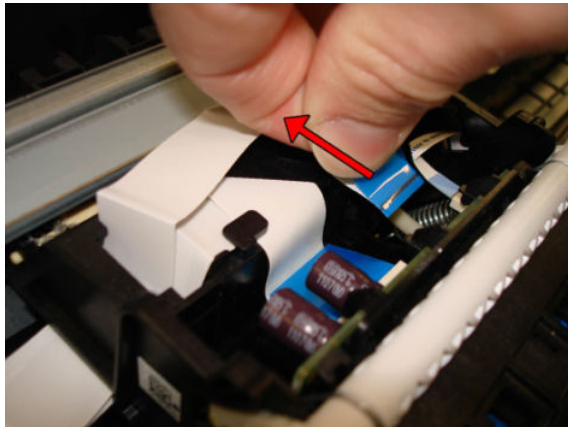

13. Put the Trailing Cable in a flat position, carefully avoiding making folds in the cable.



14. Slide out the Trailing Cable carefully through the hole.

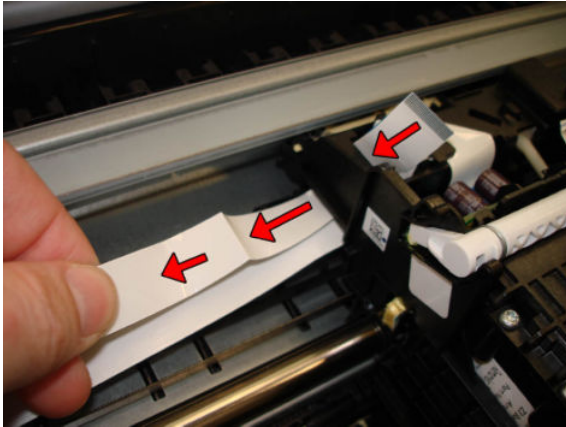

15. Disconnect the second Trailing Cable by pulling the blue plastic.

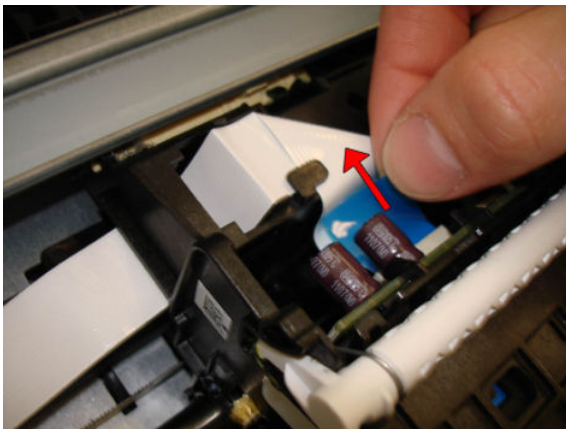

16. Put the Trailing Cable in a flat position, carefully avoiding making folds in the cable.



17. Slide out the Trailing Cable carefully through the hole.



18. Leave the two parts of the Trailing Cable hanging on the left side.

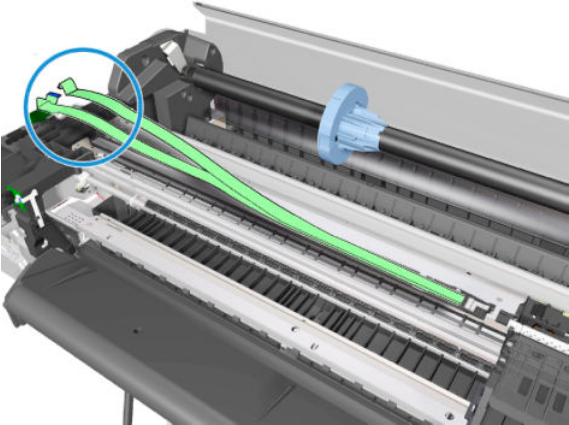

19. Disconnect the two parts of the Trailing Cable.

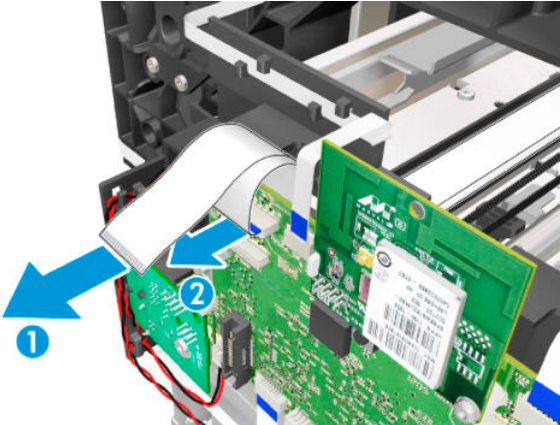

20. Remove one T-10 screw.

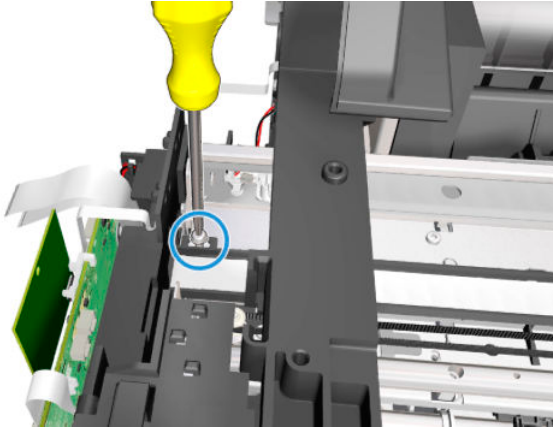

21. Unclip the flex retainer. You are recommended to wear gloves.

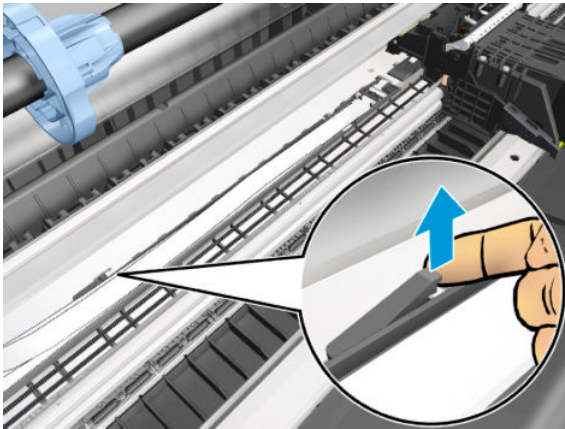

22. Slide the flex retainer to the right to unhook it.

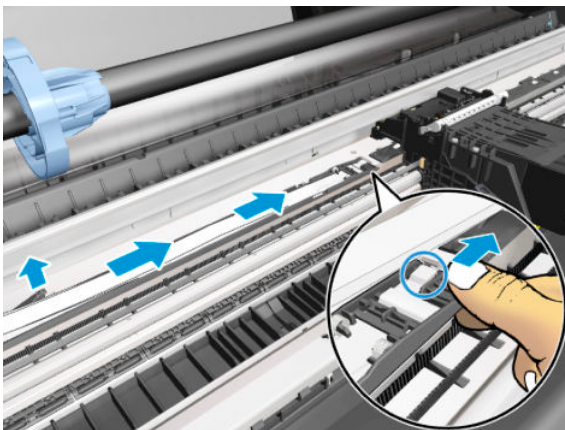

23. Slide the Trailing Cable to the right, passing the flat cables through the hole.

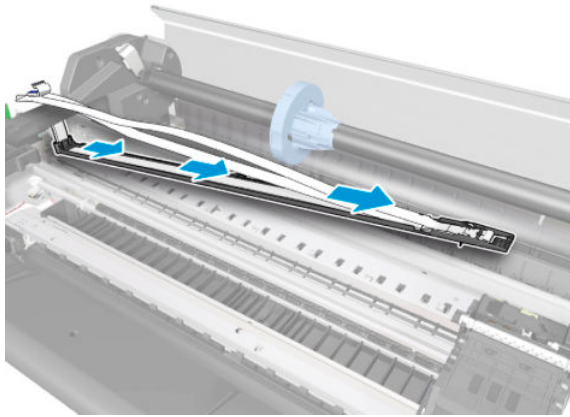

24. Remove the Trailing Cable.

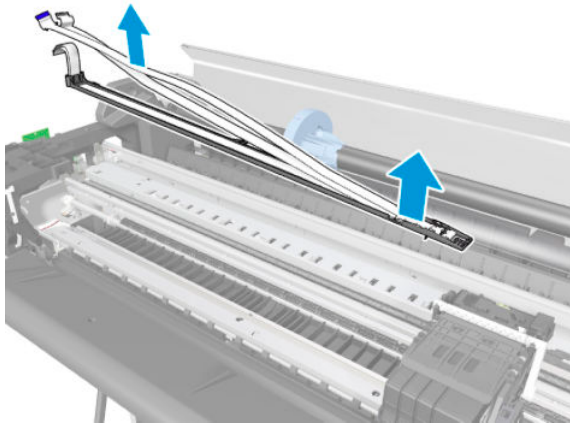

## Installation

You are recommended to wear gloves throughout the installation; and be careful not to touch the Encoder Strip.

1. Pass the Trailing Cable through the Main PCA Cover and through the ferrite.

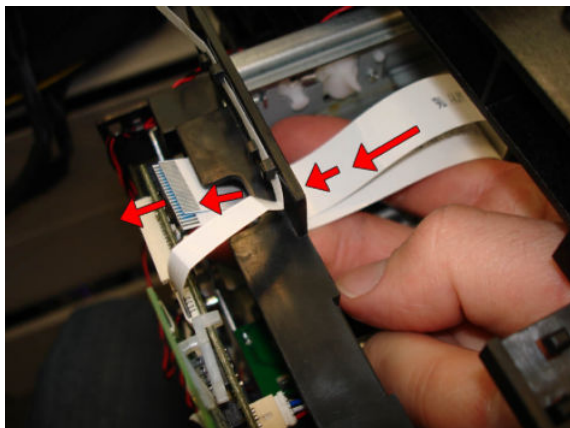

2. When connecting the cables to the Main PCA, remember that the blue side of the Trailing Cable must be facing up.

---

**CAUTION:** When connecting the two parts of the Trailing Cable, insert them into the connectors straight.

---

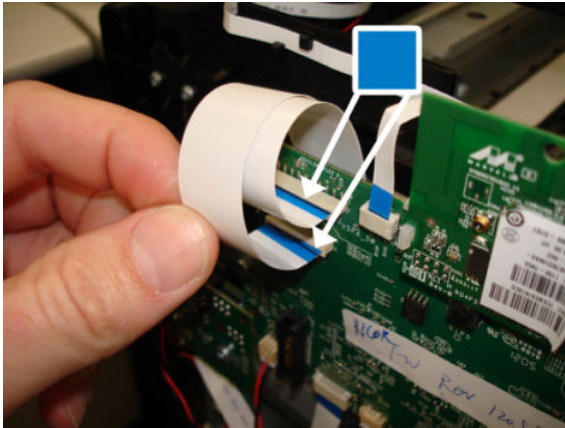

3. Hook the Trailing Cable to the two hooks.

---

**IMPORTANT:** Make sure the cables are centered and aligned with each other.

---

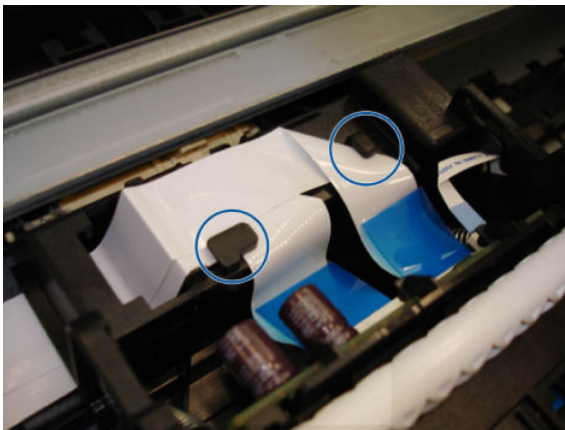

---

**NOTE:** Be careful not to damage the cables.

---

4. Remember to put back the Trailing Cable retainer.



5. When installing the PCA Carriage Cover, the letter A should be on the right side.

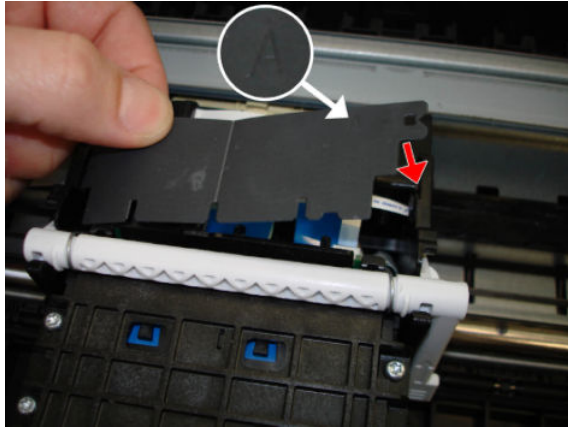

6. When the installation is complete, clean the Encoder Strip. See [Clean the Encoder Strip on page 531](#).

# Service Station

## Removal

1. Switch off the printer and remove the power cable.
2. Remove the Front Cover, see [Front Cover on page 261](#).
3. Remove the Right Cover, see [Right Cover MFP SV Kit F9A30-67011 on page 264](#).
4. Remove the ISS, see [ISS on page 499](#).
5. Uncap the Carriage.

 **CAUTION:** Avoid touching the Encoder Disk by mistake.

---

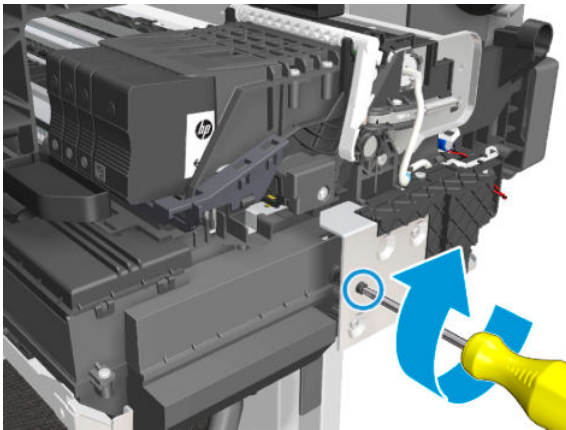

6. Move the Carriage to the left.

 **NOTE:** Image shown is from another product, and for reference only.

---

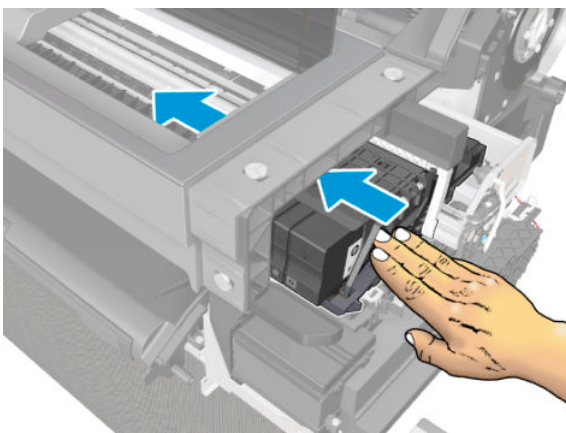

7. Unclip the tube.

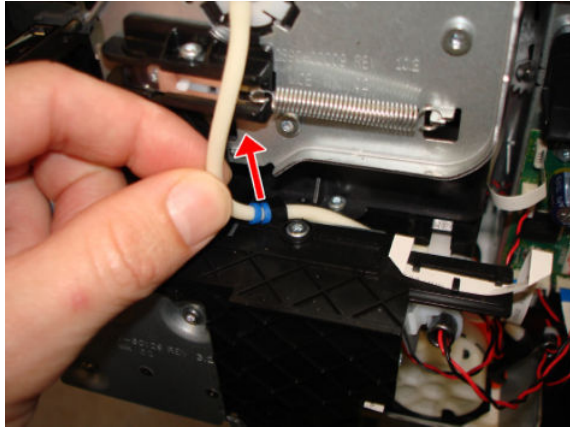

8. Unclip the Tee Pump Prime.

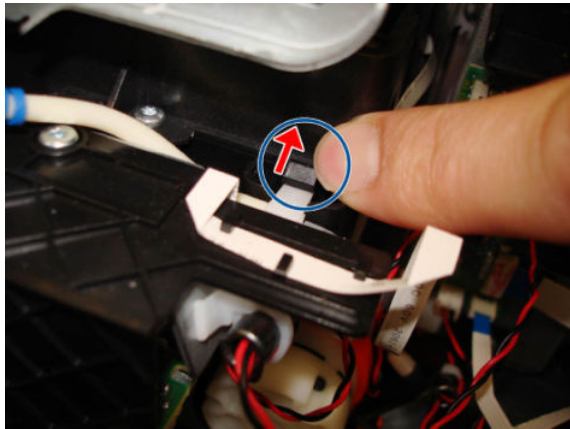

9. Remove the Tee Pump Prime.

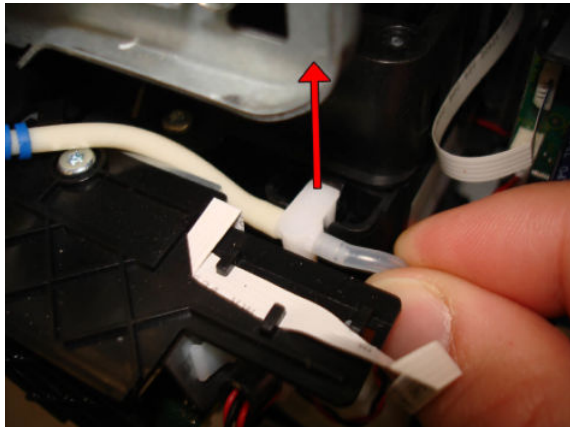

10. Disconnect the tube.

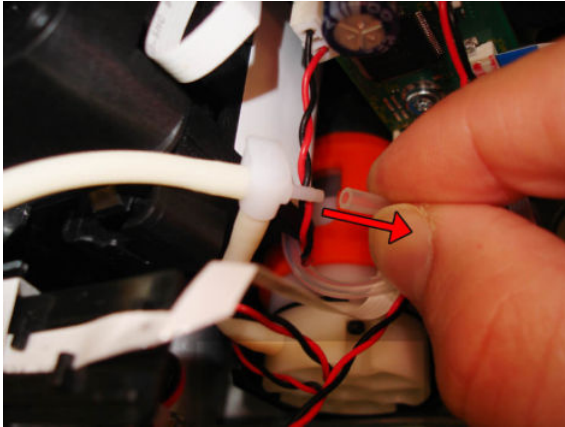

11. Disconnect the tube.

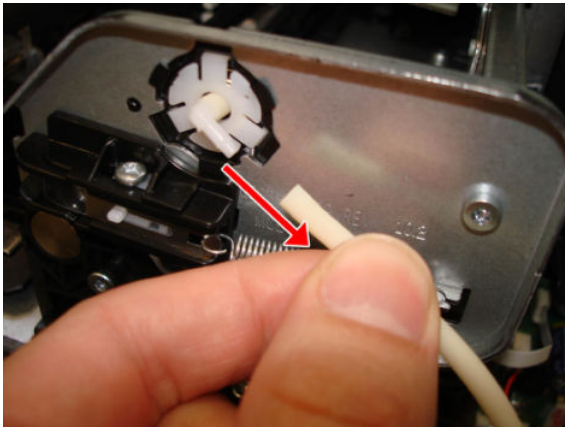

12. Disconnect the flat cable.

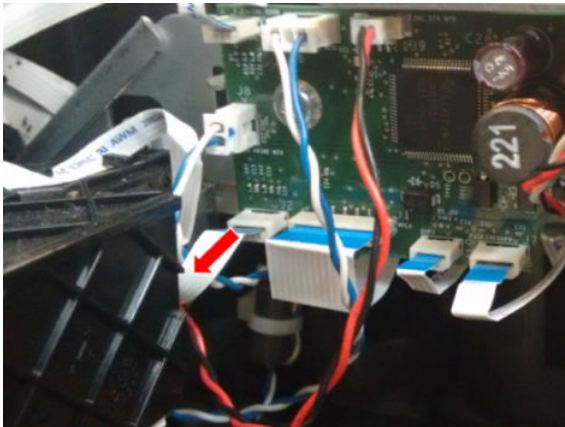

13. Unroute the cables from behind the Printer Bundle Board bracket, and remove the FFC retainers indicated.

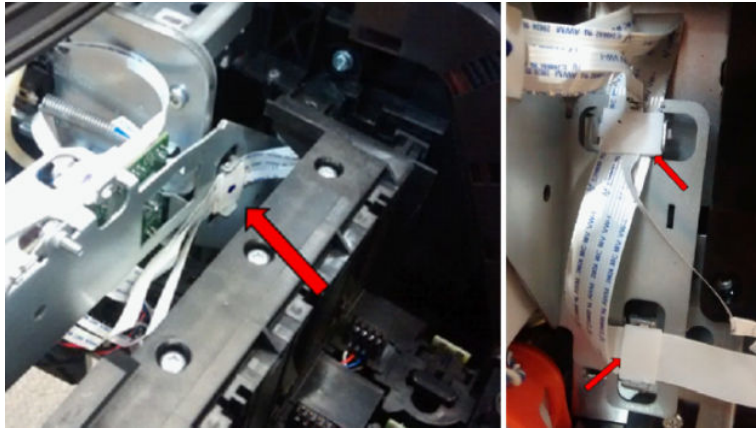

14. Disconnect the cable.

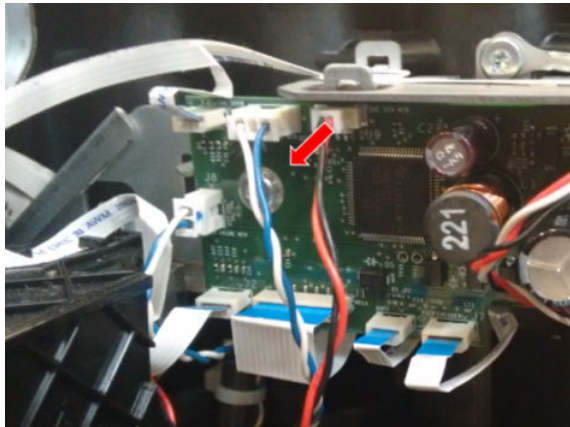

15. Remove one T-15 screw.

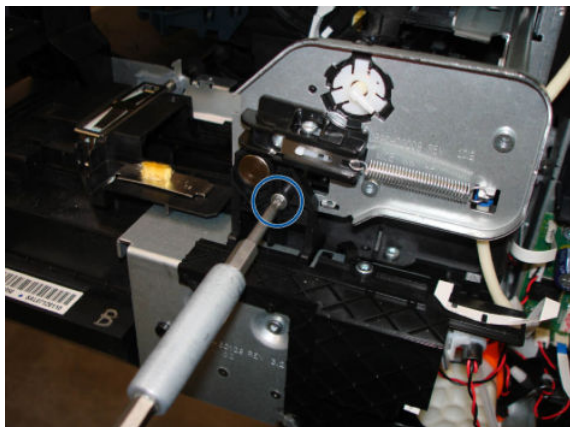

16. Loosen only one T-15 screw.

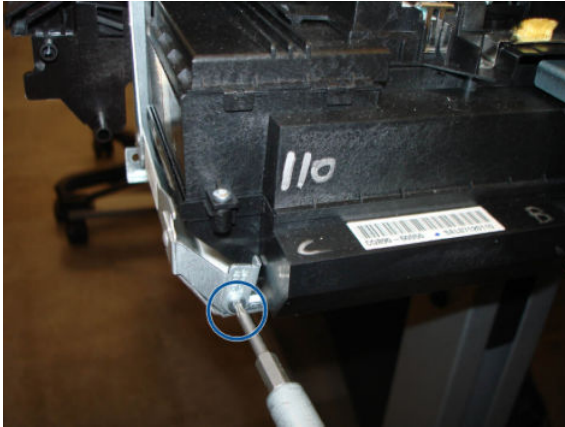

17. Rotate the Xlimiter.



18. Push down the metal sheet and slide out the Service Station.

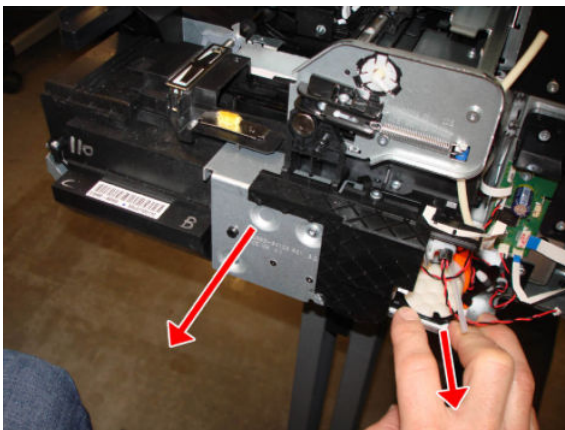

19. If, while you are sliding out the Service Station, there is an interaction with the metallic bracket, then you should push down the Service Station.

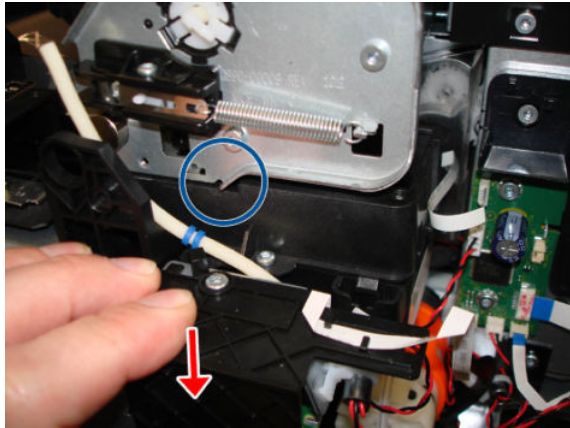

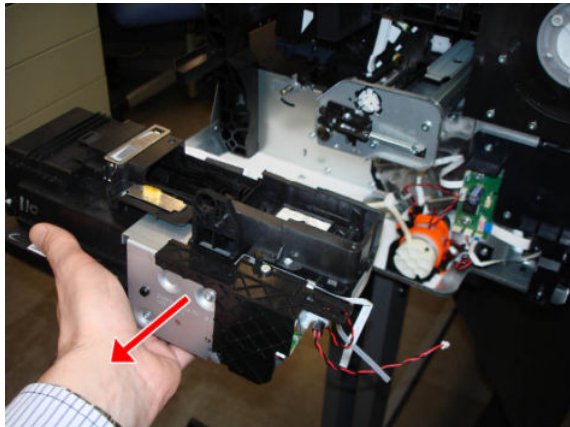

20. Remove the Service Station.

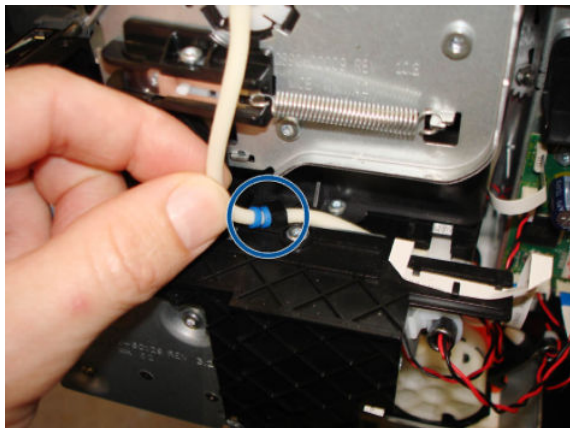

## Installation

- ▲ Install the blue washers of the tube on the left side of the hook.



 **NOTE:** After the successful installation of this part, perform the Preventive Maintenance Kit Reset procedure, see [2.7 PMK2 on page 216](#).

# Prime Pump

## Removal

1. Switch off the printer and remove the power cable.
2. Remove the Front Cover, see [Front Cover on page 261](#).
3. Remove the Right Cover, see [Right Cover MFP SV Kit F9A30-67011 on page 264](#)
4. Remove the ISS, see [ISS on page 499](#).
5. Disconnect the cable.

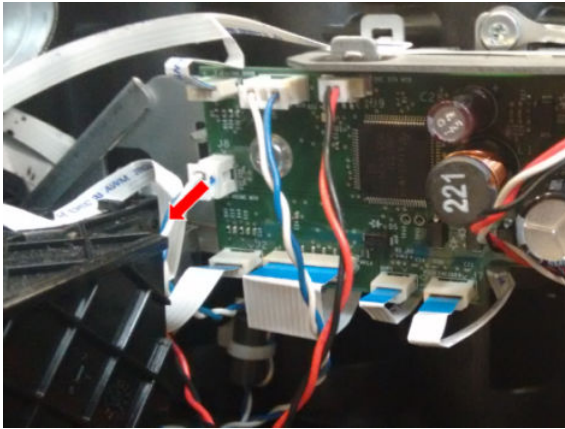

6. Disconnect the tube.

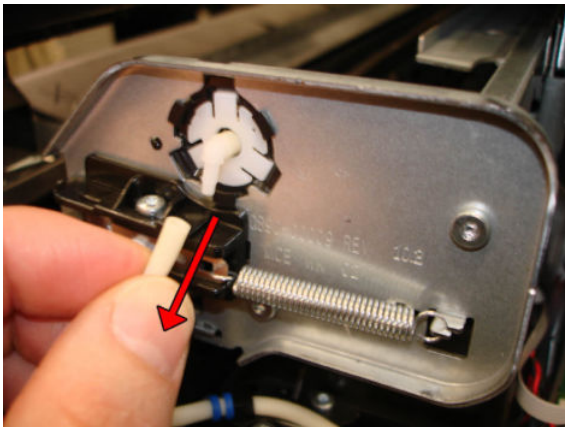



7. Unhook the cable.

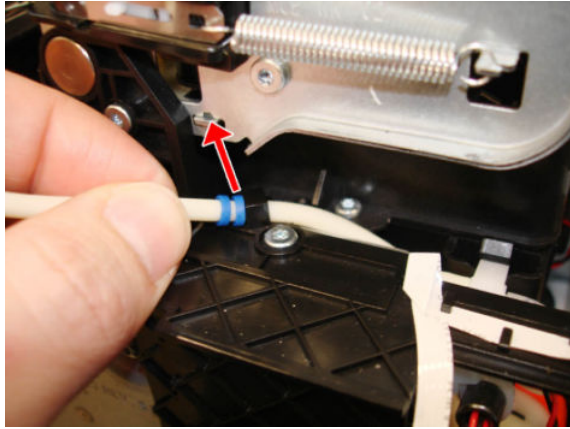

8. Unclip the Tee Pump Prime.

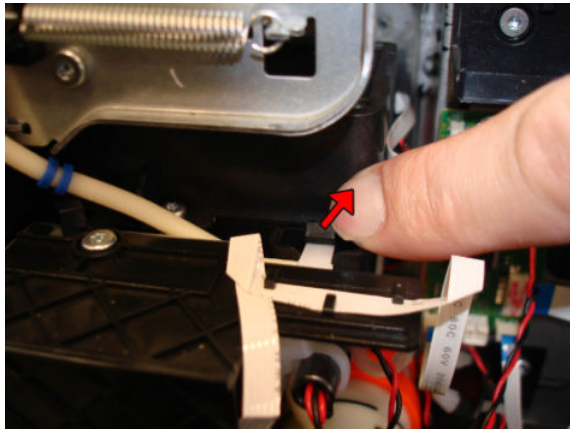

9. Remove the Tee Pump Prime.

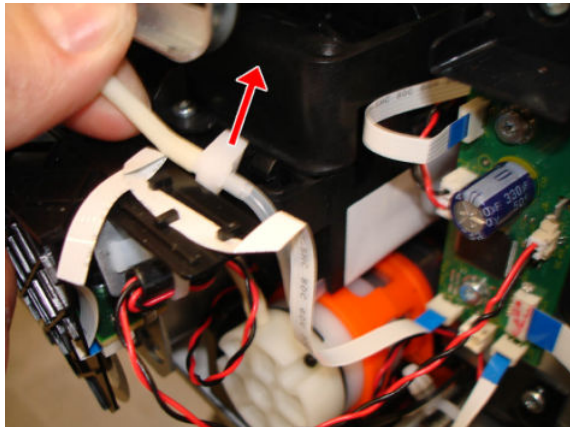

10. Disconnect the tube.

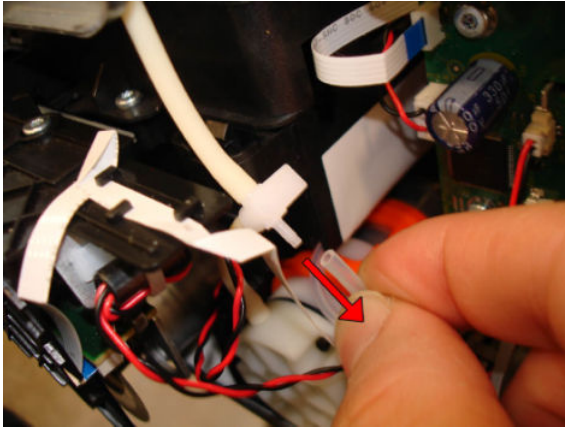

11. Remove one T-10 screw.

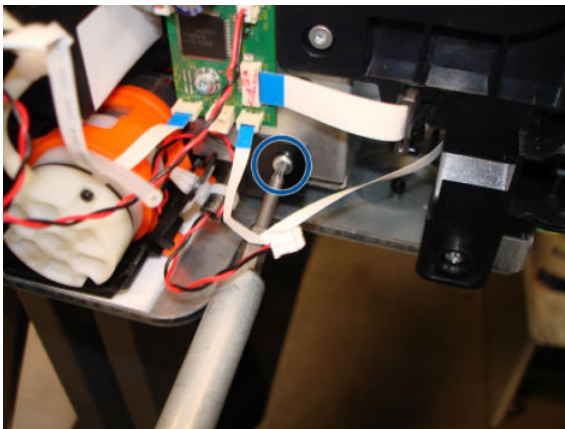

12. Remove the Prime Pump.

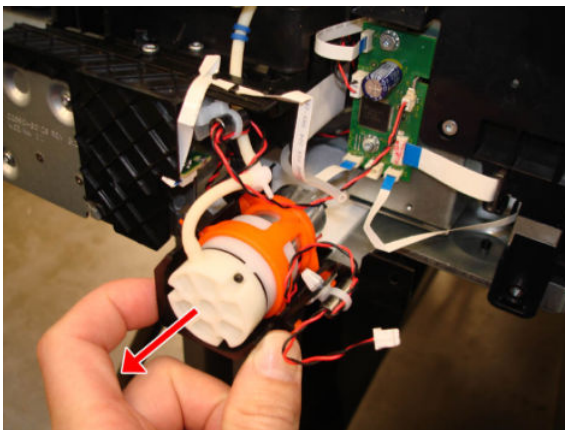

## Installation

- ▲ Reverse the removal process, fitting the tubes right up until the ends.

⚠ **CAUTION:** Take care with the fittings.

---

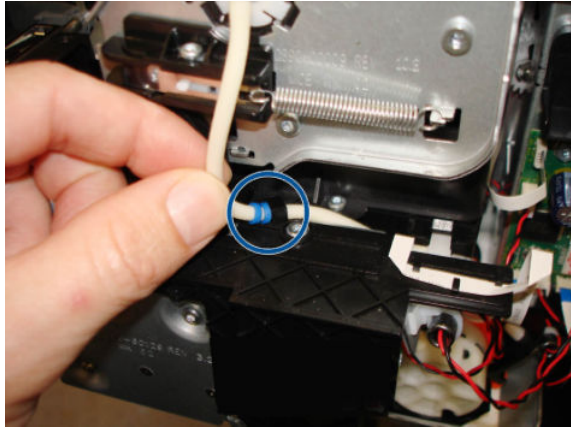

# Carriage and Belt

## Removal

1. Switch off the printer and remove the power cable.
2. **(MFP only)** Remove the Scanner Module, see [Scanner Module on page 505](#).
3. Remove the Front cover, see [Front Cover on page 261](#).
4. Remove the Cutter Door, see [Cutter Door F9A30-67006 on page 378](#).
5. Remove the Left Cover, see [Left Cover MFP SV Kit F9A30-67012 on page 268](#).
6. Remove the Right cover, see [Right Cover MFP SV Kit F9A30-67011 on page 264](#).
7. Remove the Front Panel, see [Front Panel SFP F9A29-67008 on page 278](#)

---

 **TIP:** If you want to power on the printer, the Front Panel can be placed on clips (without cover).

---

8. Remove the Central Cover, see [Central Cover on page 284](#).
9. Remove the Service Station, see [Service Station on page 334](#).

---

 **NOTE:** Do not touch the Service Station's Encoder Disk when handling the Service Station.

---

10. Remove Encoder Strip, see [Encoder Strip on page 300](#).
11. Remove the Ink Cartridges, see [Replace an ink cartridge on page 122](#).
12. Make sure the Carriage is in this position.

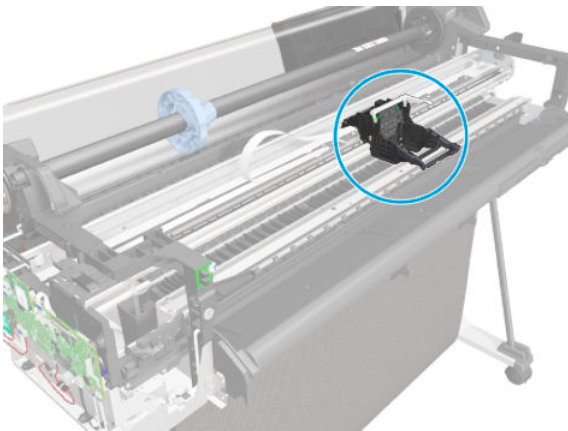

13. Disconnect the two flat cables from the PCA.

 **NOTE:** Image shown is from another product, and for reference only.

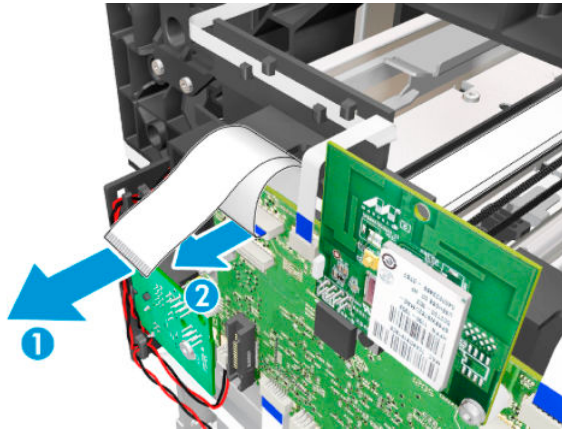

14. Remove one T-15 screw from the left side.

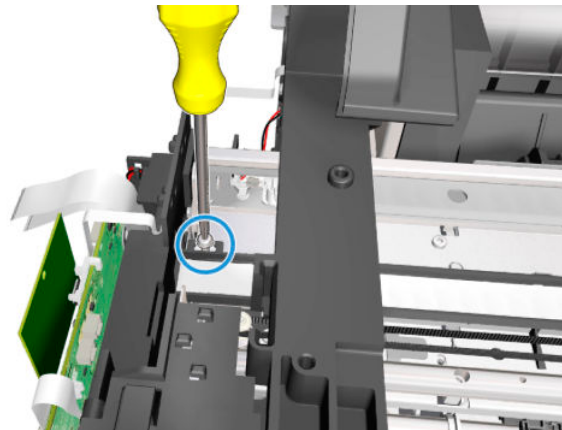

15. Unclip the trailing cable retainer clip shown here (1) and slide it to the right (2).

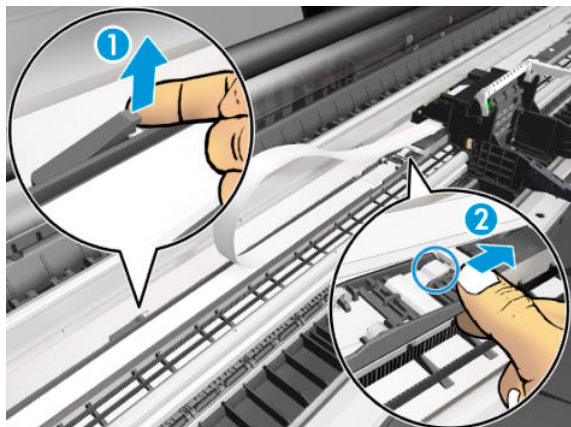

16. Slide the trailing cables retainer to the right.

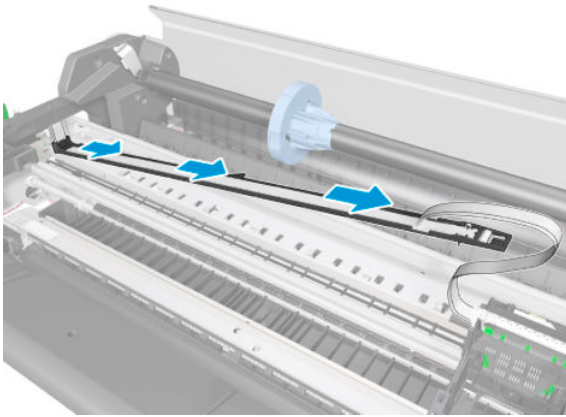

17. Leave the trailing cables retainer on the platen.

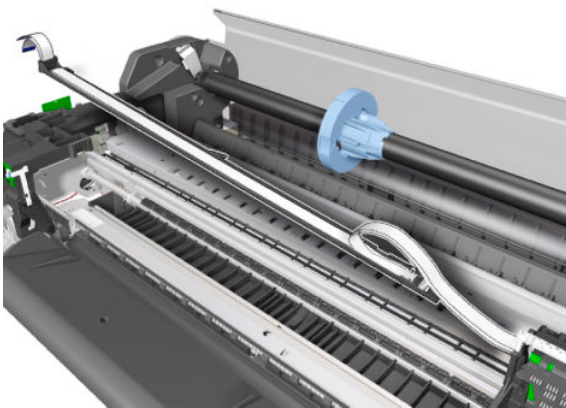

18. Remove two T-10 screws from the Right End Plate.

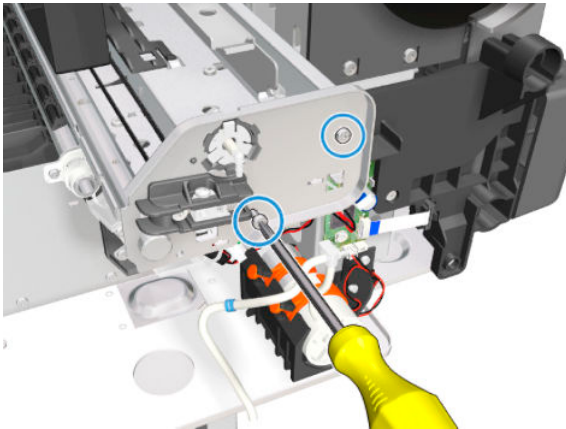

**19.** Remove the Right End Plate.

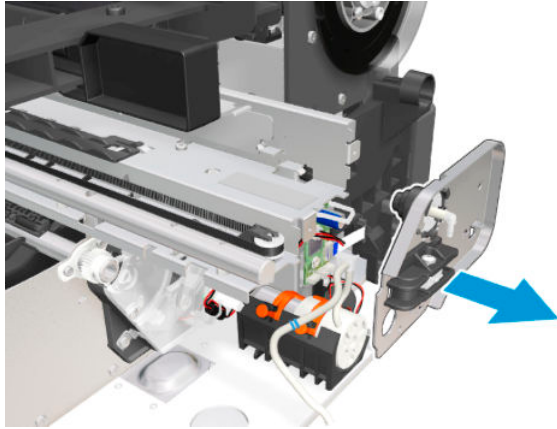

**20.** Unhook the Carriage Belt with a finger and lift it away.

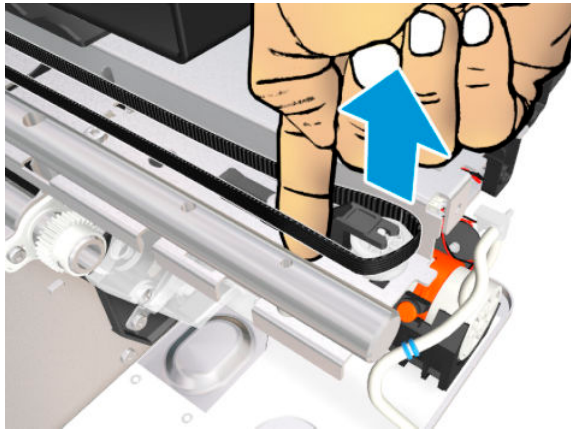

**21.** Remove the Carriage Belt from the end pulley.

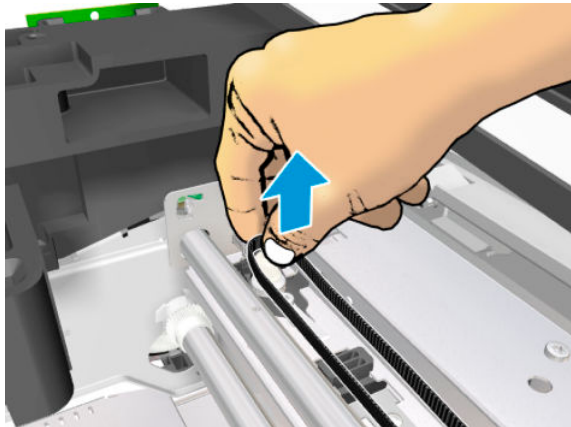

22. Remove one T-15 screw .

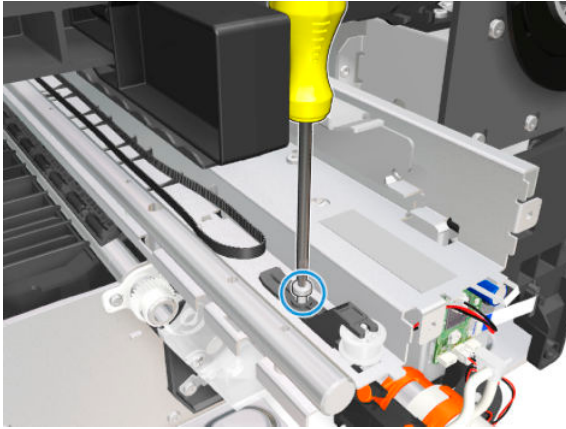

23. Unclip the pulley latch shown here (1) and slide it to the right (2).

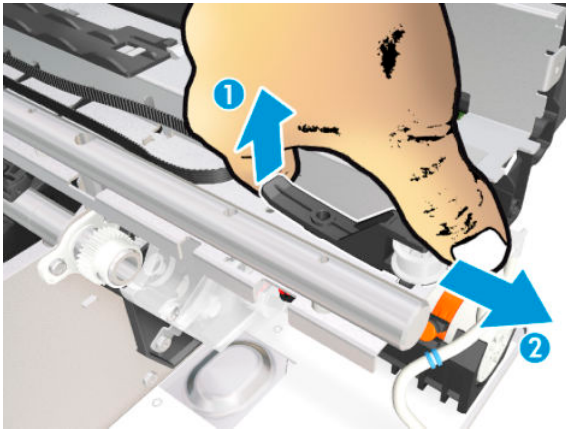

24. Remove the pulley latch..

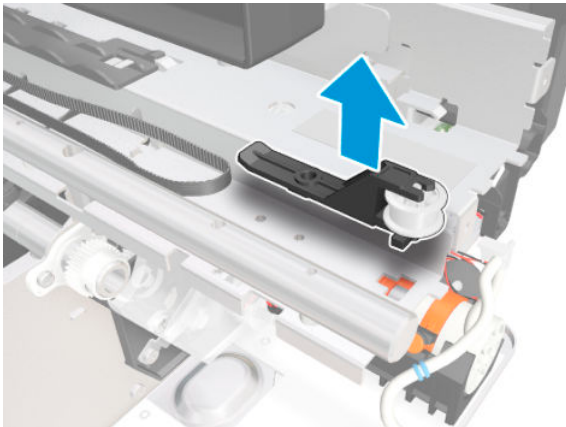



25. Pull the latch down.

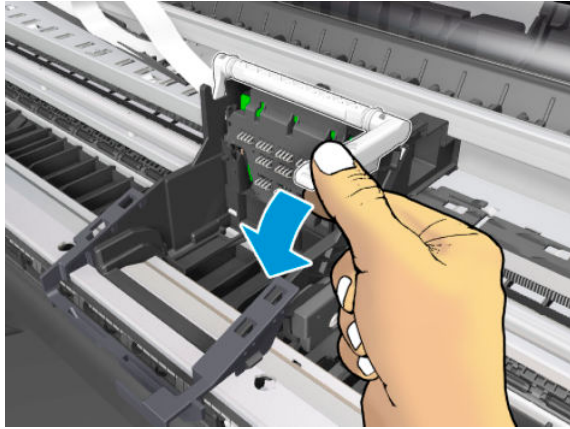

26. Slide the Carriage, the Belt, and the Trailing Cable to the right.

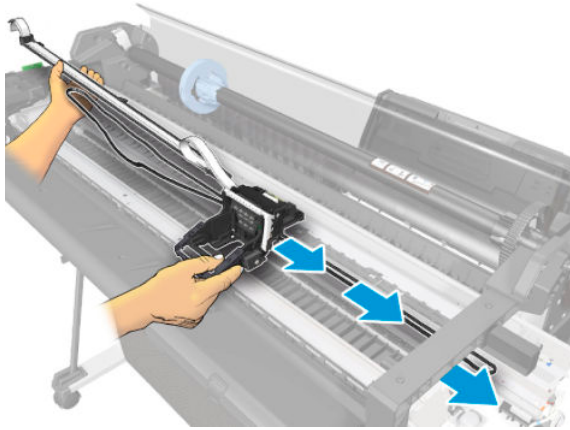

27. Remove the Carriage Assembly.

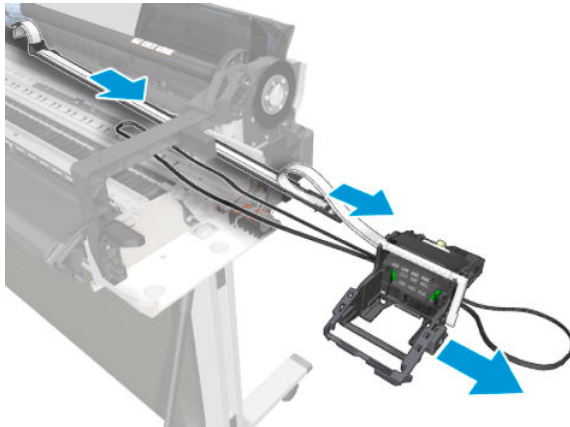

## Installation

1. To reinstall the Belt, use a screwdriver to lever the Belt back on.

2. When installing the Carriage Assembly, make sure you slide the part indicated here onto the slider rod.

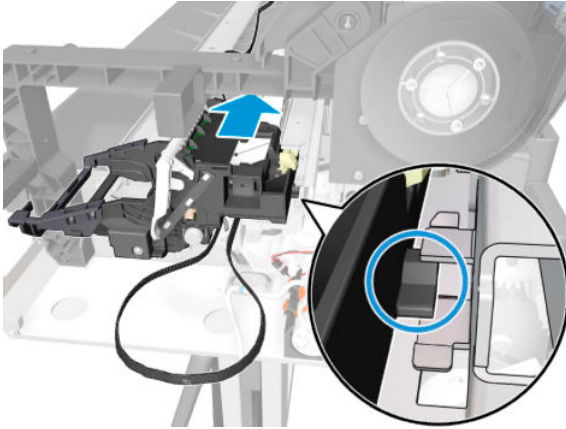

3. When the installation is complete, clean the Encoder Strip (see [Clean the Encoder Strip on page 531](#)) and the Line Sensor (see [Clean the Carriage Line Sensor on page 530](#)).

# Carriage Belt

## Removal

1. Switch off the printer and remove the power cable.
2. **(MFP only)** Remove the Scanner Module, see [Scanner Module on page 505](#).
3. Remove the Front Cover, see [Front Cover on page 261](#).
4. Remove the Cutter Door, see [Cutter Door F9A30-67006 on page 378](#).
5. Remove the Left Cover, see [Left Cover MFP SV Kit F9A30-67012 on page 268](#).
6. Remove the Right Cover, see [Right Cover MFP SV Kit F9A30-67011 on page 264](#).
7. Remove the Front Panel, see [Front Panel SFP F9A29-67008 on page 278](#).
8. Remove the Central Cover, see [Central Cover on page 284](#).
9. Remove the Service Station, see [Service Station on page 334](#).
10. Remove the Ink Cartridges, see [Replace an ink cartridge on page 122](#).
11. Remove the Encoder Strip, see [Encoder Strip on page 300](#).
12. Remove the printhead, see [Replace the printhead on page 124](#).
13. Remove the Carriage, see [Carriage and Belt on page 344](#).
14. Rotate the Carriage to see the bottom side.



15. Slide the Carriage Belt.

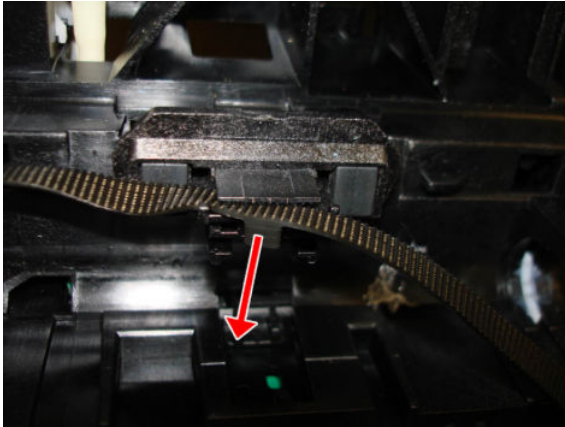

16. Remove the Carriage Belt.

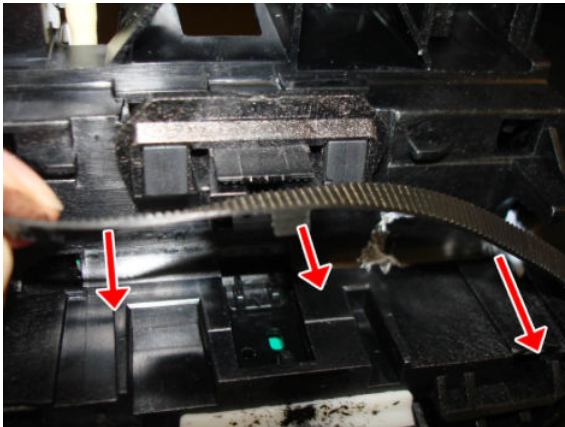

 **NOTE:** After the successful installation of this part, perform the Preventive Maintenance Kit Reset procedure, see [2.6 PMK1 on page 216](#).

# Right Gear Train Module

## Removal

1. Switch off the printer and remove the power cable.
2. Remove the Front Cover, see [Front Cover on page 261](#).
3. Remove the Right Cover, see [Right Cover MFP SV Kit F9A30-67011 on page 264](#).
4. Remove the Service Station, see [Service Station on page 334](#).
5. Remove the Prime Pump, see [Prime Pump on page 340](#).
6. Remove the Multi-Sheet Tray, see [Multi-Sheet Tray Assembly on page 367](#).
7. Disconnect the flat cable.

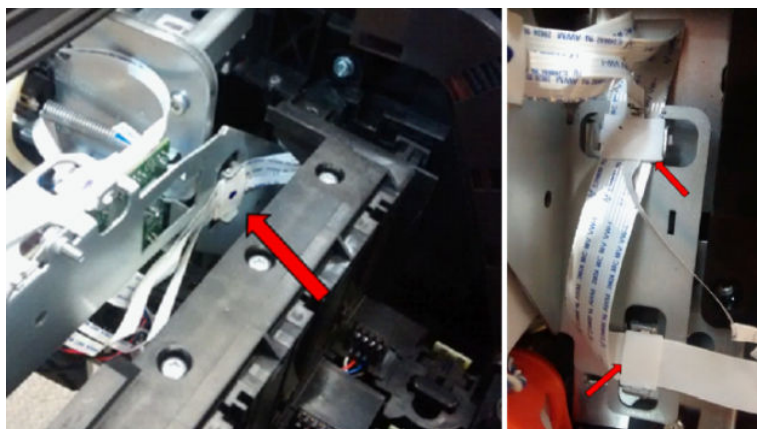
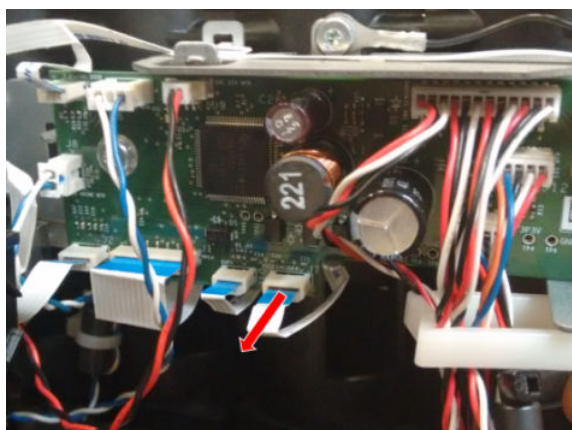

8. Disconnect the motor cable.

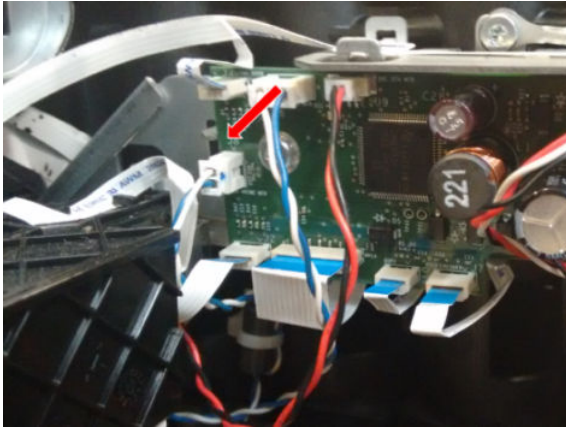

9. Remove three T-10 screws.

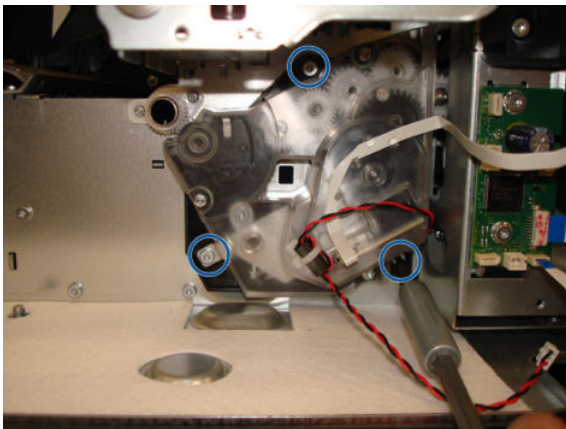

10. Slide the Right Gear Train Module horizontally to detach the pins.

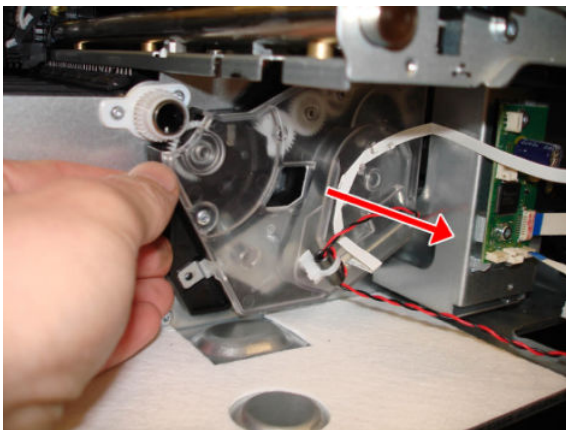

**11. Remove the Right Gear Train Module.**

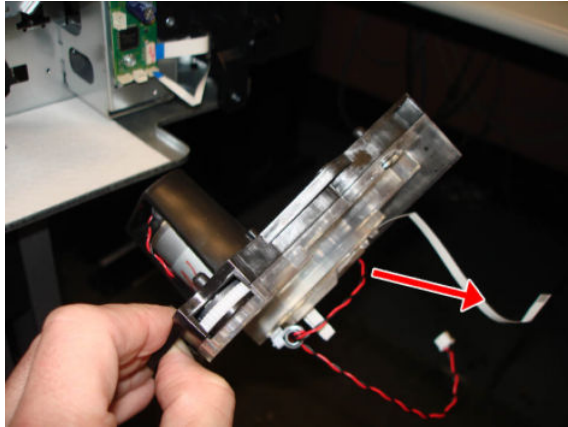

**Installation**

- ▲ Install the Right Gear Train Module by reversing the removal process.

# Starwheel Assembly

## Removal

1. Switch off the printer and remove the power cable.
2. **(MFP only)** Remove the Scanner Module, see [Scanner Module on page 505](#).
3. Remove the Front Cover, see [Front Cover on page 261](#).
4. Remove the Cutter Door, see [Cutter Door F9A30-67006 on page 378](#).
5. Remove the Left Cover, see [Left Cover MFP SV Kit F9A30-67012 on page 268](#).
6. Remove the Right Cover, see [Right Cover MFP SV Kit F9A30-67011 on page 264](#).
7. Remove the Front Panel, see [Front Panel SFP F9A29-67008 on page 278](#).
8. Remove the Central Cover, see [Central Cover on page 284](#).
9. Remove one T-10 screw on the left side of the Starwheel Assembly.

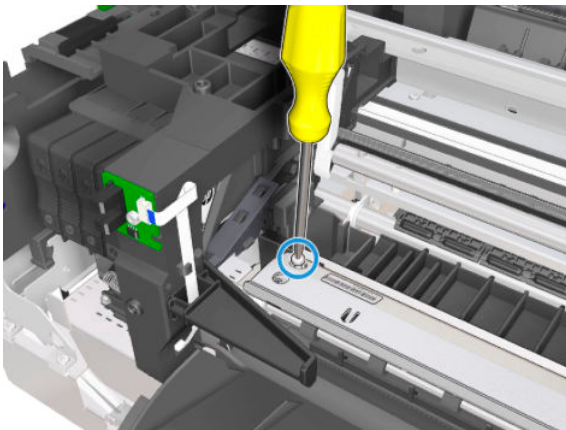

10. Remove one T-10 screw on the right side of the Starwheel Assembly.



**NOTE:** Image shown is from another product, and for reference only.

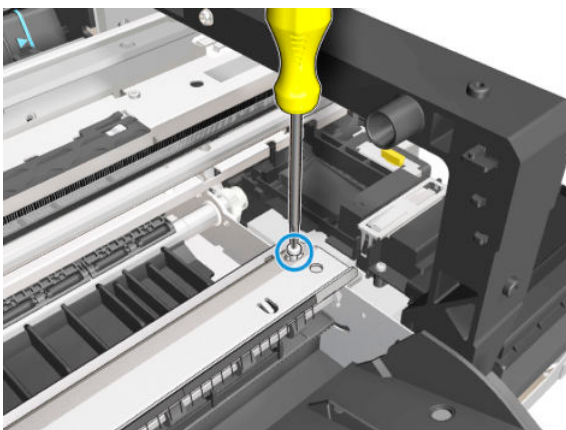



11. Detach the Starwheel Assembly from the two hooks by sliding it up.

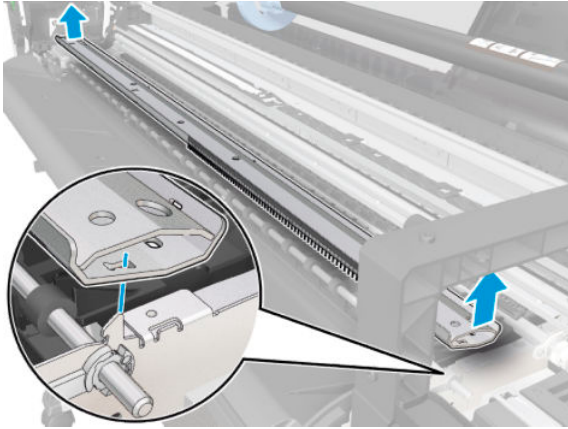

12. Remove the Starwheel Assembly.



### Installation

- ▲ When installing the Starwheel Assembly, make sure it is located correctly on the hooks.

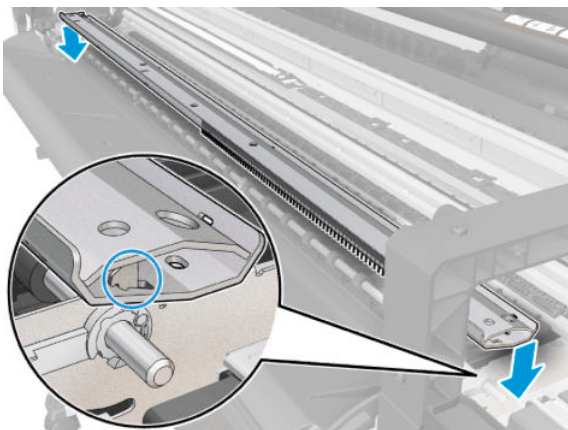

# Output Shaft

## Removal

1. Switch off the printer and remove the power cable.
2. **(MFP only)** Remove the Scanner Module, see [Scanner Module on page 505](#).
3. Remove the Front Cover, see [Front Cover on page 261](#).
4. Remove the Cutter Door, see [Cutter Door F9A30-67006 on page 378](#).
5. Remove the Left Cover, see [Left Cover MFP SV Kit F9A30-67012 on page 268](#).
6. Remove the Right Cover, see [Right Cover MFP SV Kit F9A30-67011 on page 264](#).
7. Remove the Front Panel, see [Front Panel SFP F9A29-67008 on page 278](#).
8. Remove the Central Cover, see [Central Cover on page 284](#).
9. Remove the Main PCA, see [Main PCA on page 311](#).
10. Remove the Starwheel, see [Starwheel Assembly on page 356](#).
11. Uncap the Carriage and move it to the left of the printer.
12. Pull the Right Bearing to unclip it from the hole.

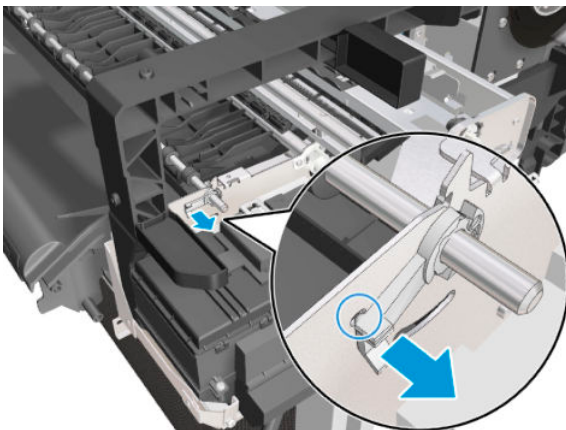

13. Rotate the Right Bearing.

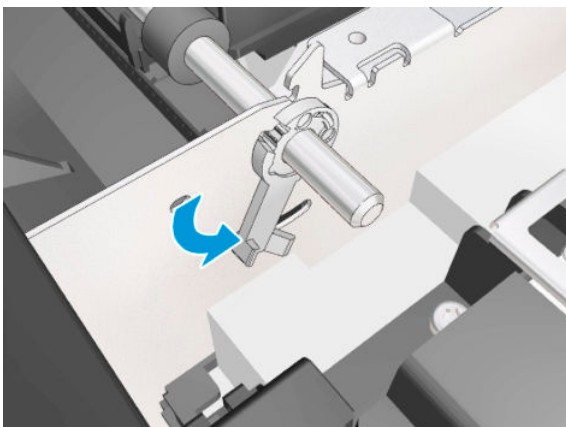

14. Move the Carriage from the left to the right side of the printer.

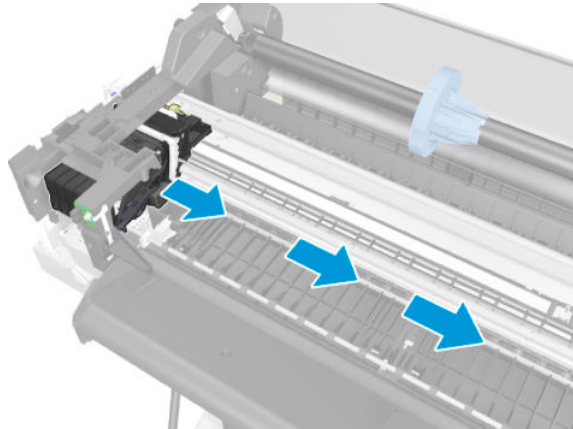

15. Leave the Carriage as shown below, without touching it with the Output Shaft.

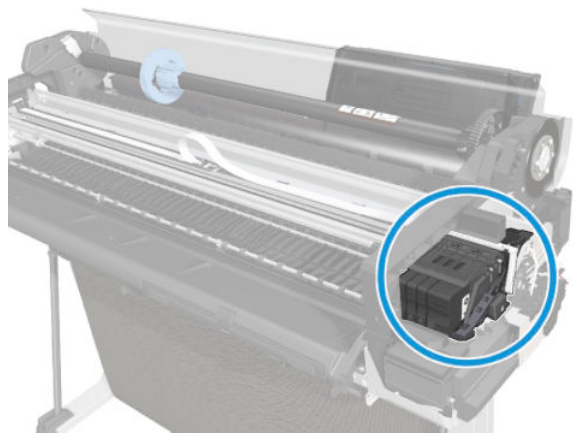

16. Move the cutter to the right and leave it in the middle of the Platen.

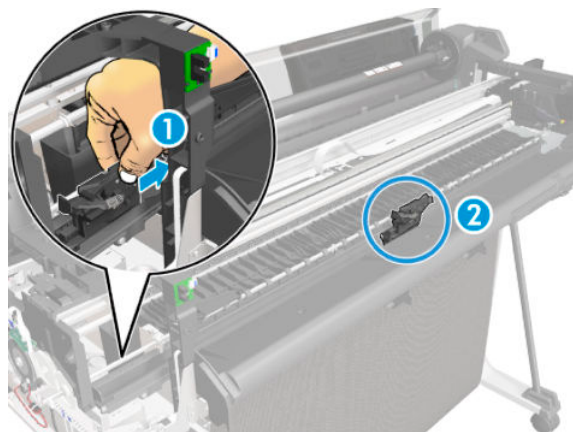

17. Unroute the flat cable.

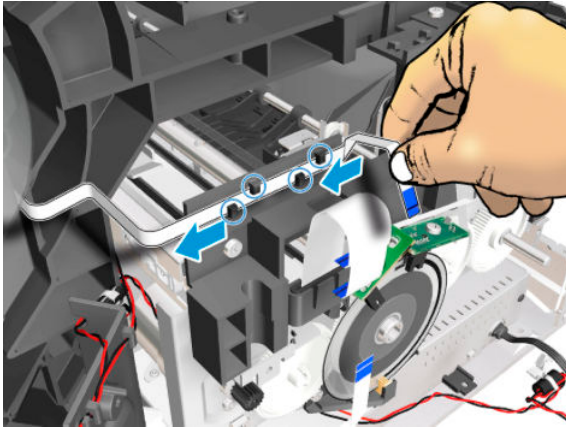

18. Remove one T-10 screw.

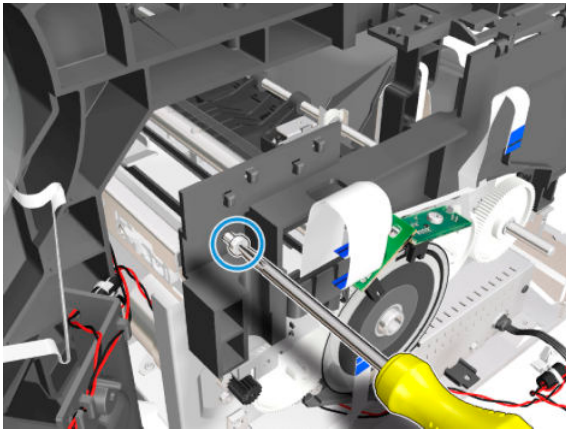

19. Rotate the Bridge FFC.

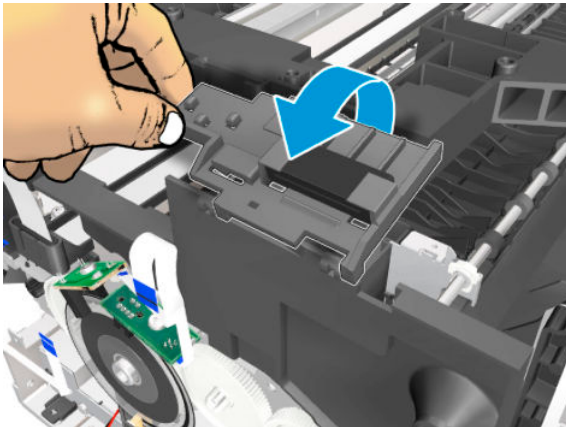

20. Slide the Bridge FFC (1) and remove it (2).

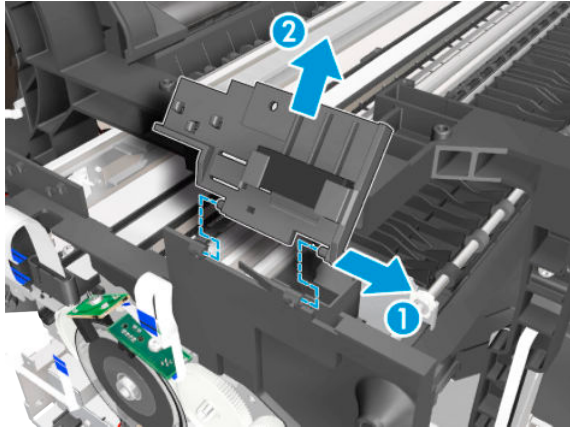

21. Detach the Main PCA Cover from the bracket.

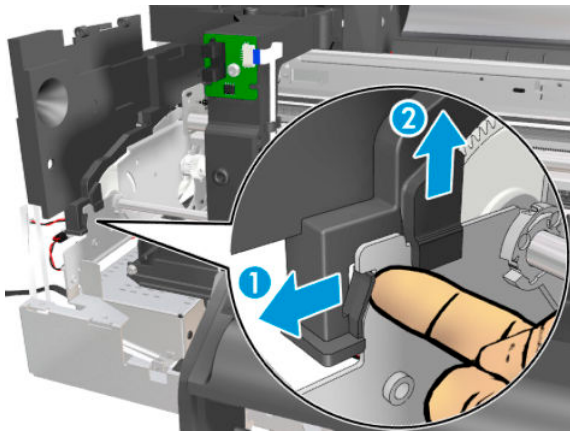

22. Remove the Main PCA Cover.

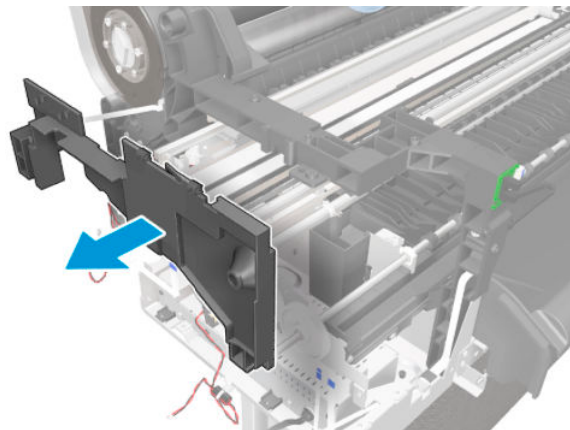

23. Pull the Left Bearing to unclip it from the hole (1), then rotate it (2).

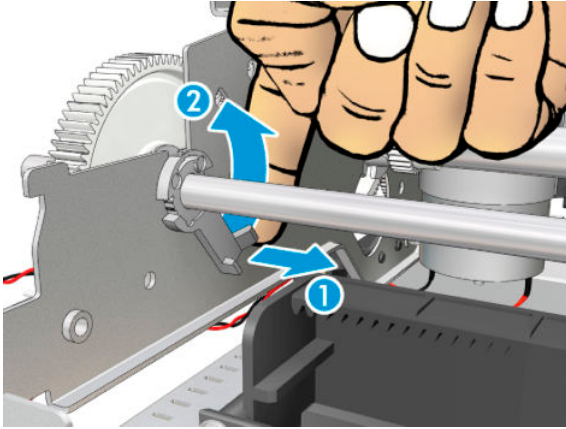

24. Slide the Left Bearing to the right.

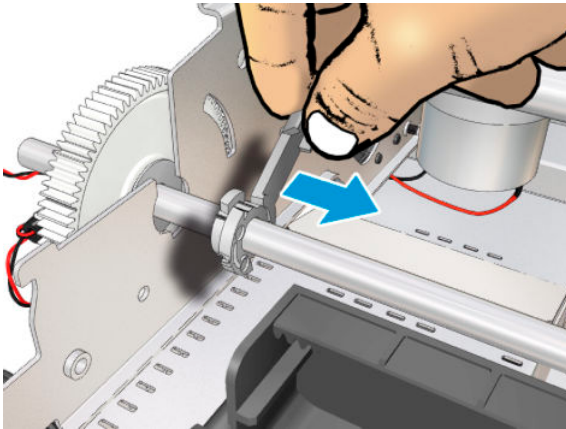

25. Move the Output Shaft up to detach the Middle Bearing.

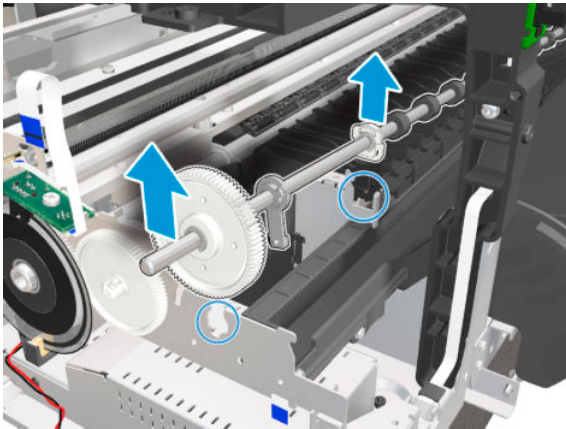

26. Slide the Output Shaft to the left to release it from the hole.

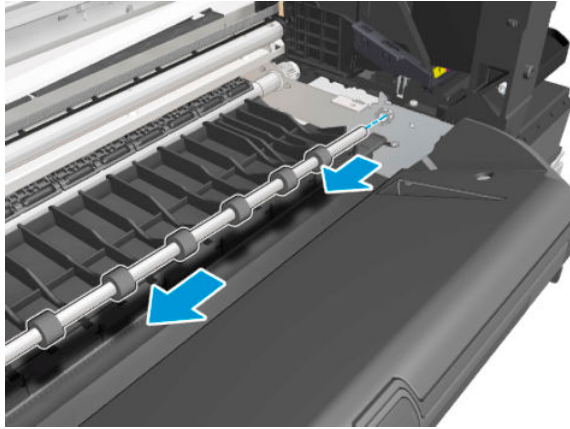

27. Remove the Output Shaft .

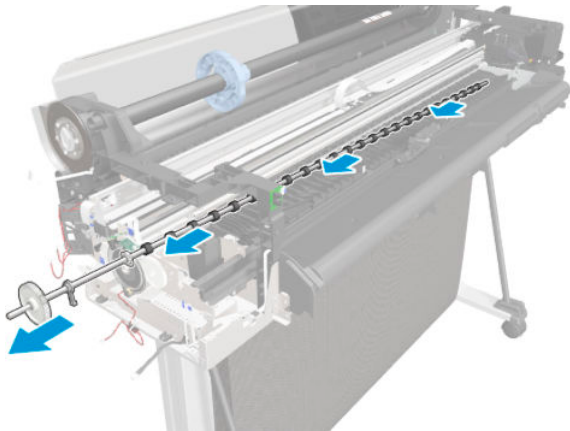

## Installation

1. If you find the Middle Bearing mounted from the factory in a different position (rotated by 180°), this is also correct.

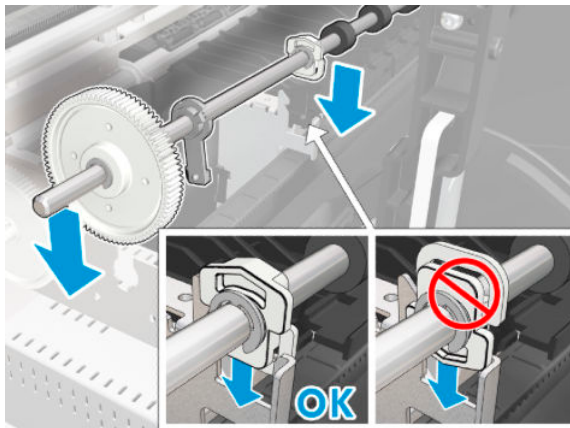

2. Make sure the Middle Bearing is mounted correctly.

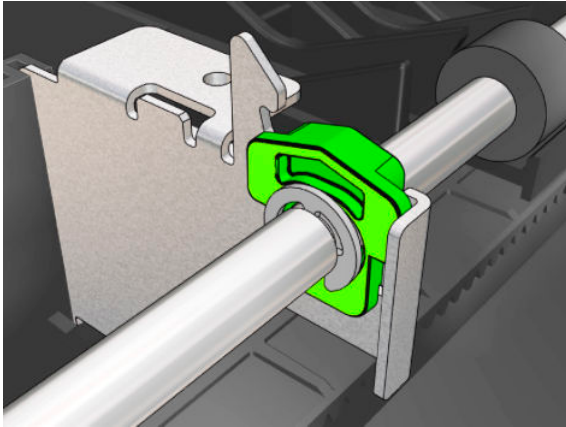

3. Put the Left Bearing in this position to mount to the left bracket.

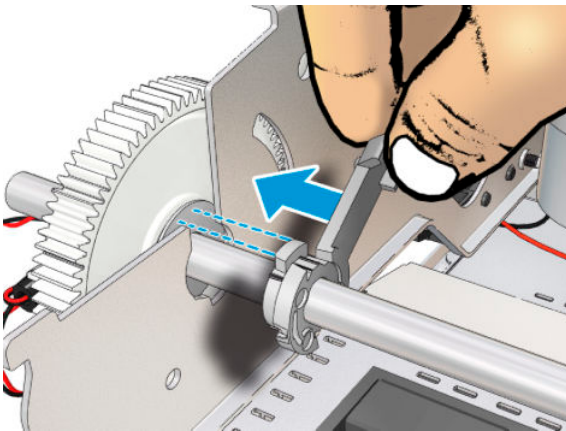

4. Rotate the Left Bearing until it clips into the hole.

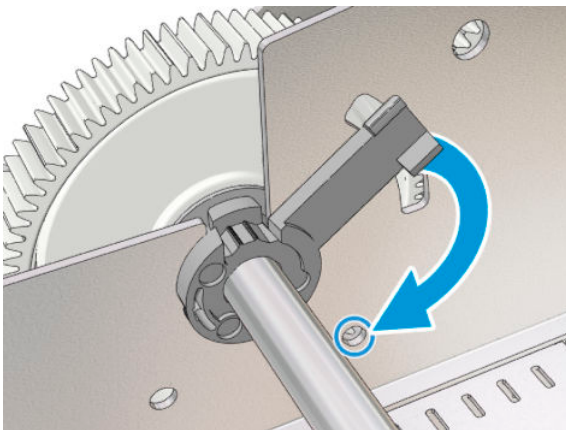



# Output Tray

## Removal

1. Turn off the printer.
2. Lock the castors of the printer's stand.

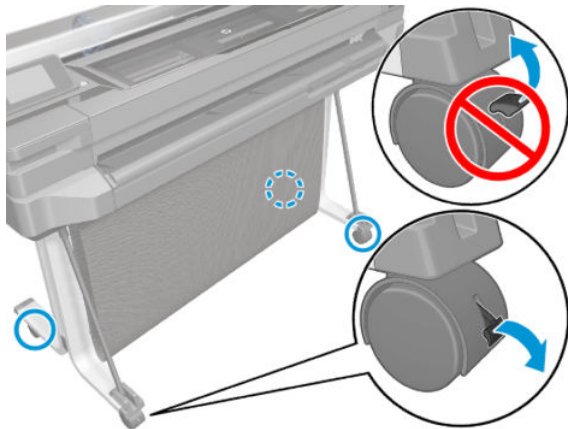

3. Pull out the Output Tray.



4. Pull out the Output Tray to the A4 position.

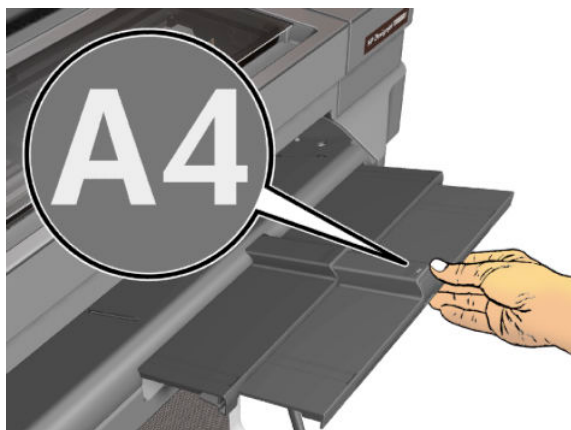

5. Bend the Output Tray slightly as shown below.

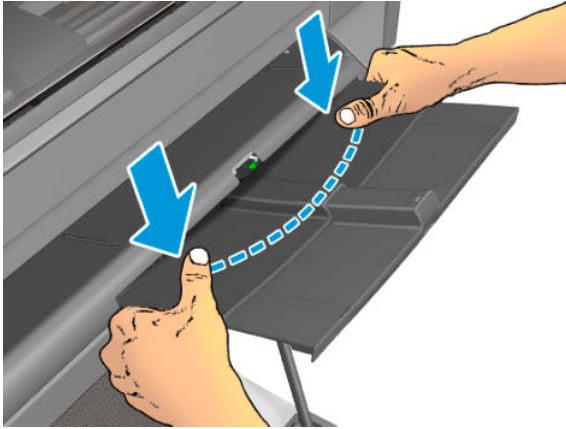

6. At the same time, pull out the Output Tray.

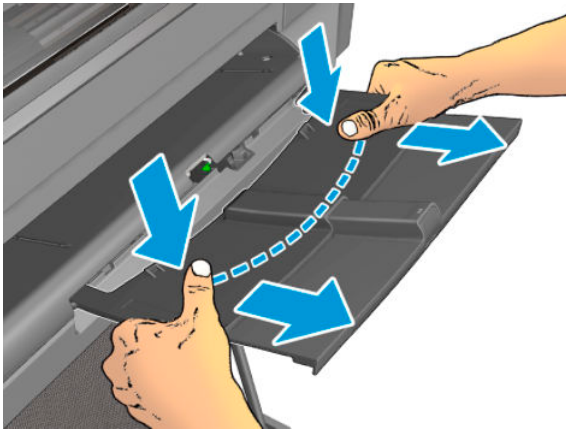

7. Remove the Output Tray.

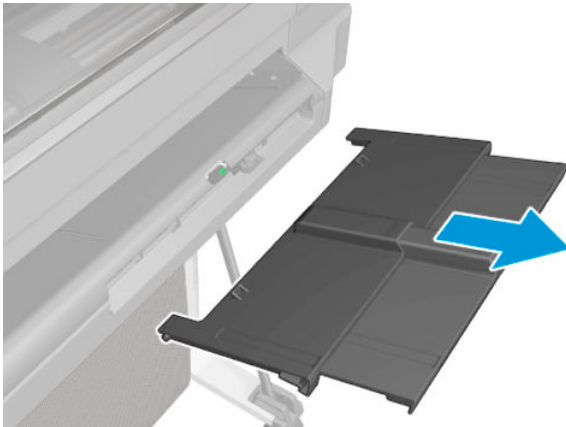

### Installation

- ▲ Install the Output Tray by reversing the removal process.

# Multi-Sheet Tray Assembly

## Removal

1. Unlock the Multi-Sheet Tray Assembly .

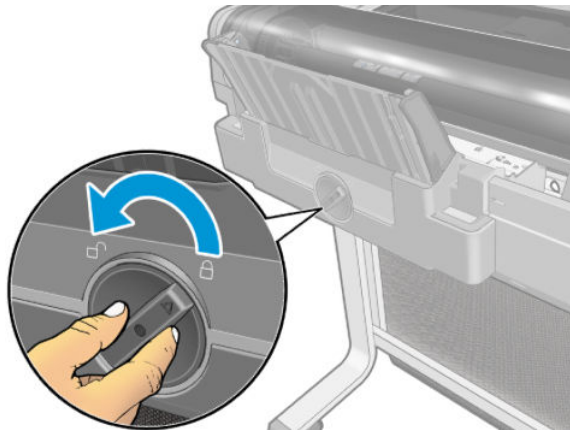

2. Pull out the Multi-Sheet Tray Assembly.

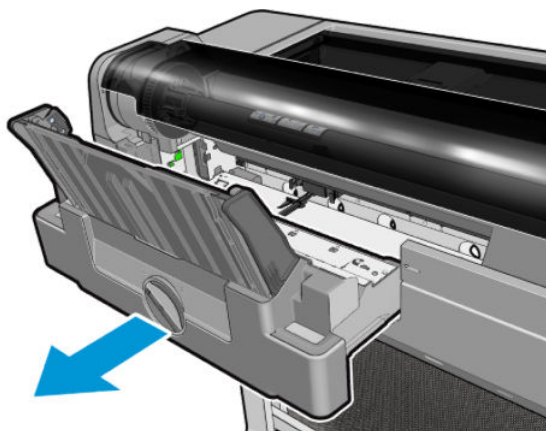

# Multi-Sheet Tray Assembly Extensions

## Removal

1. Pull out the Multi-Sheet Tray Assembly Extensions to the A3 position.

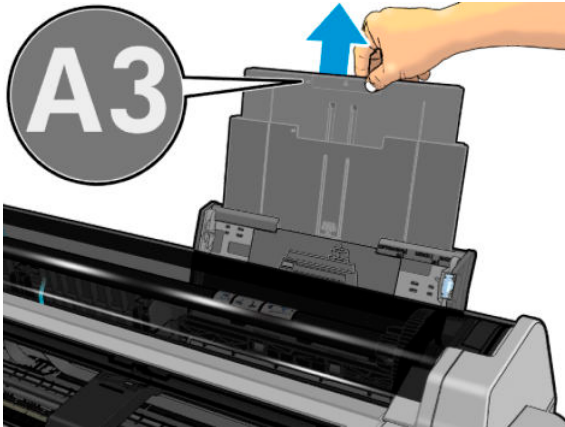

2. Unclip the Extensions from the assembly.



3. Bend the Extensions slightly as shown below.



4. Remove the Extensions.

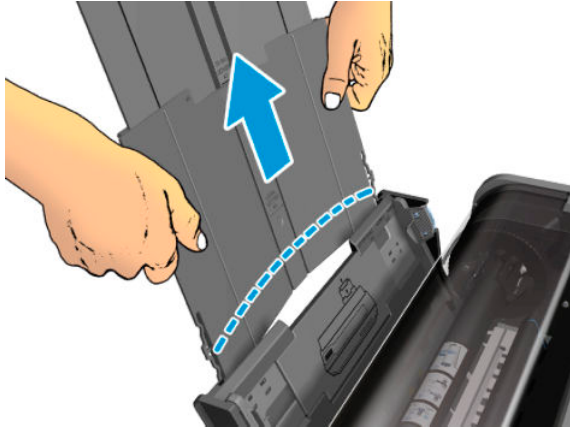

### Installation

- ▲ Install the Multi-Sheet Tray Assembly Extensions by reversing the removal process.

# Output Platen

## Removal

1. Switch off the printer and remove the power cable.
2. **(MFP only)** Remove the Scanner Module, see [Scanner Module on page 505](#).
3. Remove the Front Cover, see [Front Cover on page 261](#).
4. Remove the Cutter Door, see [Cutter Door F9A30-67006 on page 378](#).
5. Remove the Left Cover, see [Left Cover MFP SV Kit F9A30-67012 on page 268](#).
6. Remove the Right Cover, see [Right Cover MFP SV Kit F9A30-67011 on page 264](#).
7. Remove the Front Panel, see [Front Panel SFP F9A29-67008 on page 278](#).
8. Remove the Central Cover, see [Central Cover on page 284](#).
9. Remove the Output Tray, see [Output Tray on page 365](#).
10. Remove the Cutter Extraction Lid.

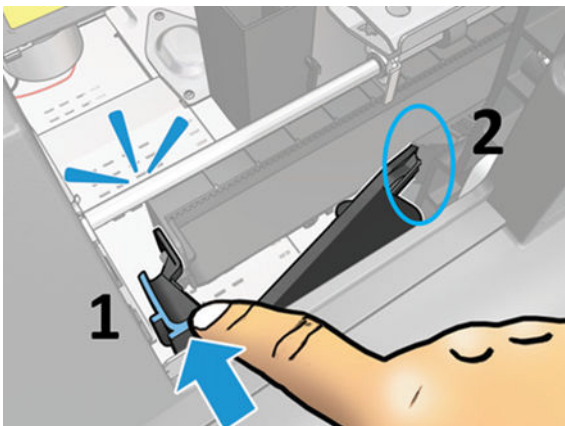

11. Remove T-10 screws:
  - 3 vertical screws
  - 7 horizontal screws



**NOTE:** A special screwdriver is required for the screw on the right as the arch blocks vertical access. If the screw cannot be tightened, there will be no functional impact on the customer unit.



**12.** Remove two T-10 screws.

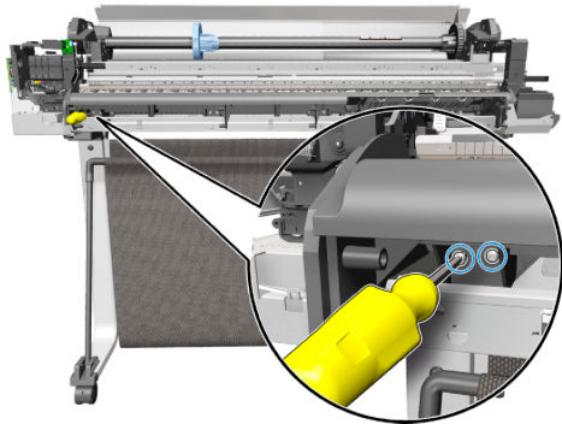

**13.** Remove two T-10 screws.

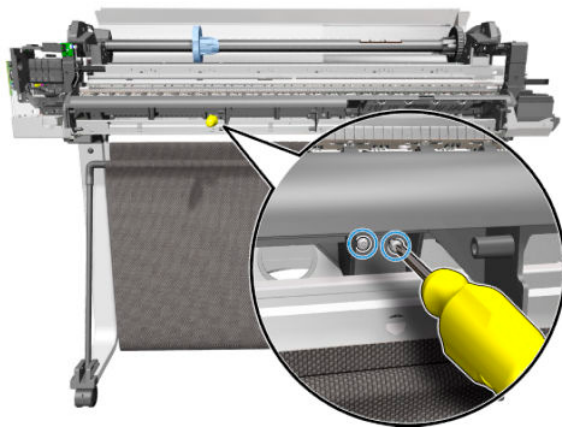

14. Remove two T-10 screws.

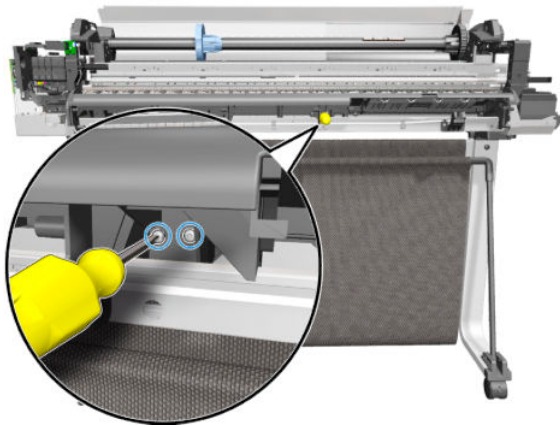

15. Remove one T-10 screw.

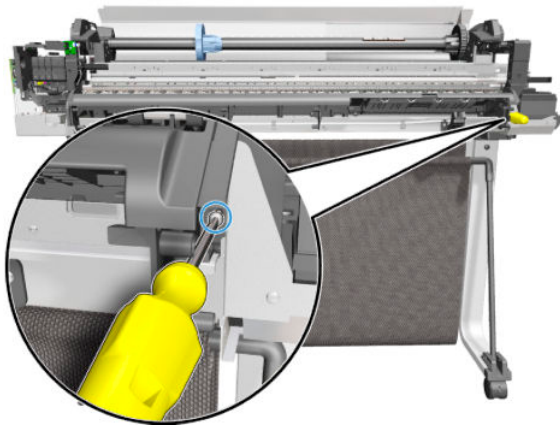

16. Remove the Output Platen.

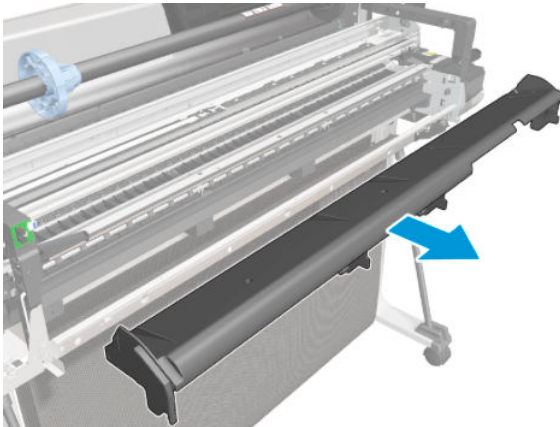

## Installation

1. There are 4 pins and locators when mounting the Output Platen.



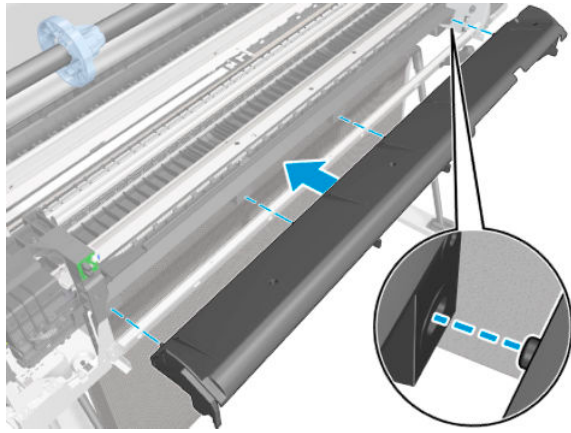

2. Introduce the Cutter Extraction Lid into the hole.

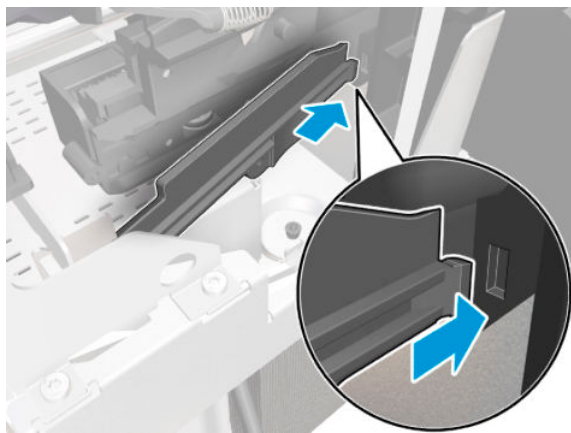

3. Ensure that the part indicated below is located correctly as you install it.

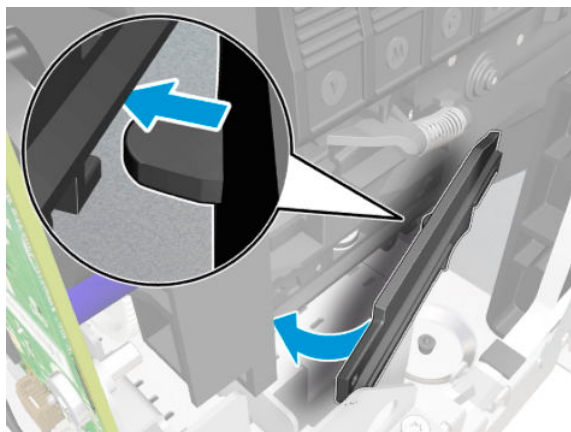

# Carriage Motor

## Removal

1. Switch off the printer and remove the power cable.
2. Remove the Front Cover, see [Front Cover on page 261](#).
3. Remove the Cutter Door, see [Cutter Door F9A30-67006 on page 378](#).
4. Remove the Left Cover, see [Left Cover MFP SV Kit F9A30-67012 on page 268](#).
5. Remove the Front Panel, see [Front Panel SFP F9A29-67008 on page 278](#).
6. Remove the Power Supply, see [Power Supply on page 308](#).
7. Disconnect the Carriage Motor Cable.

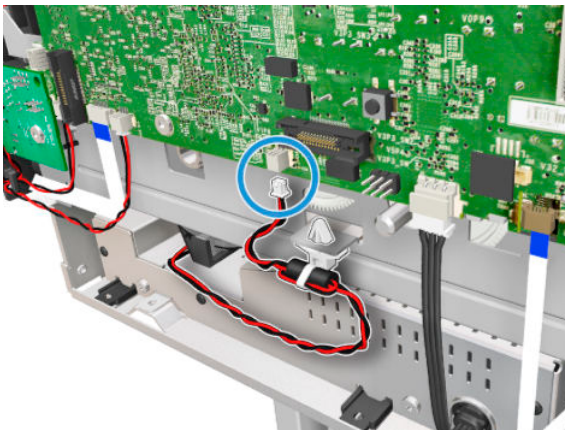

8. Unclip it from the holder in the chassis.

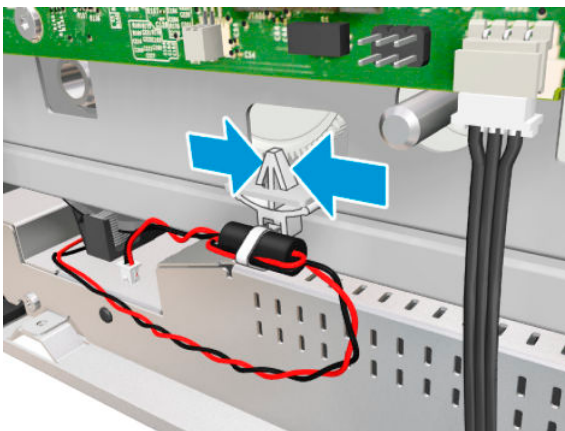

9. Remove the Carriage Motor Cable.

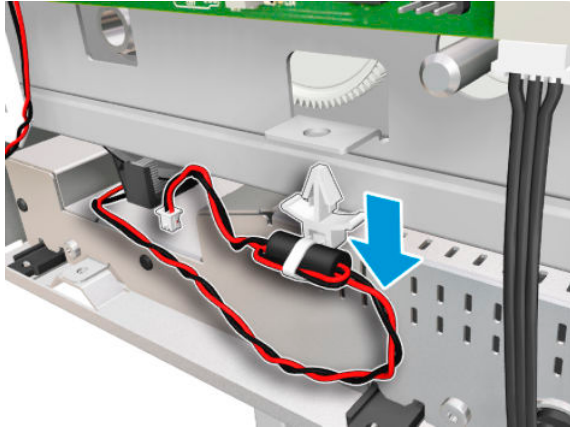

10. Keep the screwdriver inserted while levering and at the same time releasing the left end of the Belt from the Carriage Pulley Motor.

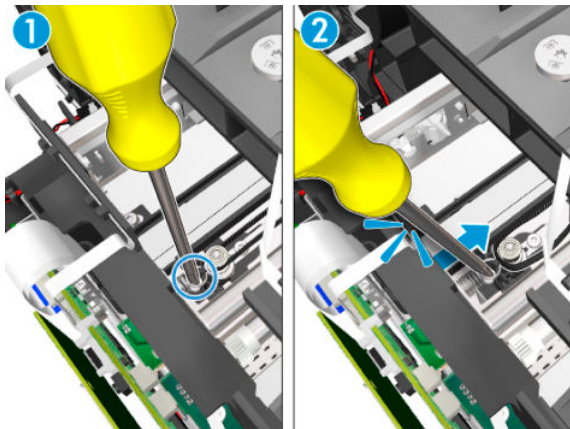

11. Remove the Carriage Belt from the pulley.

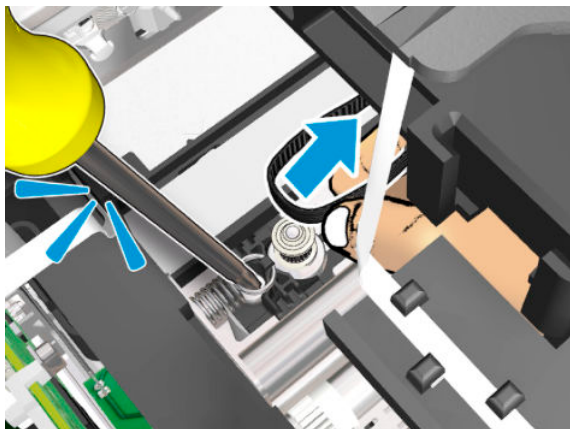

12. Remove two T-15 screws.



13. Move the Cutter to the right in order to have better access to the motor.

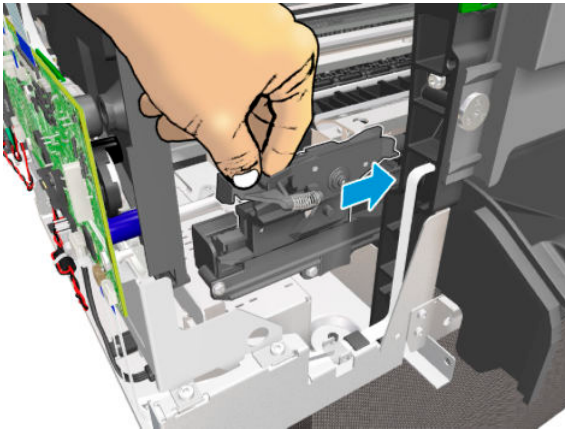

14. Rotate the Carriage Motor to have better access to it.

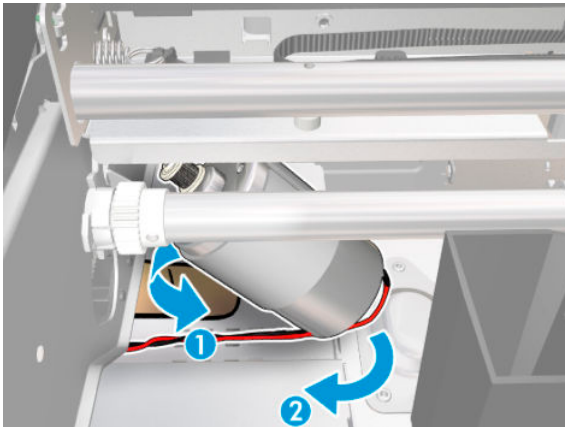

**15. Remove the Carriage Motor.**

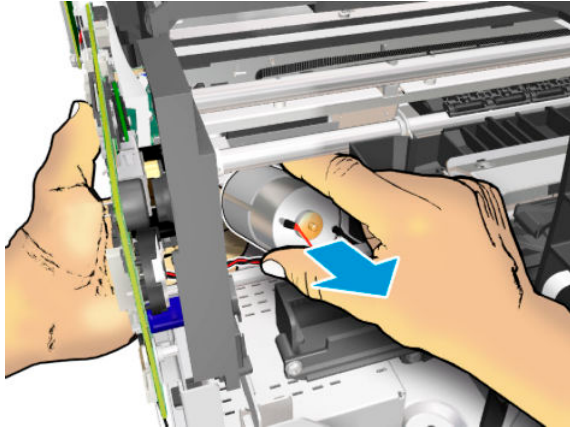

**Installation**

- ▲ When you attach the left end of the Encoder Strip to the hook, make sure the position of the face is as shown below.

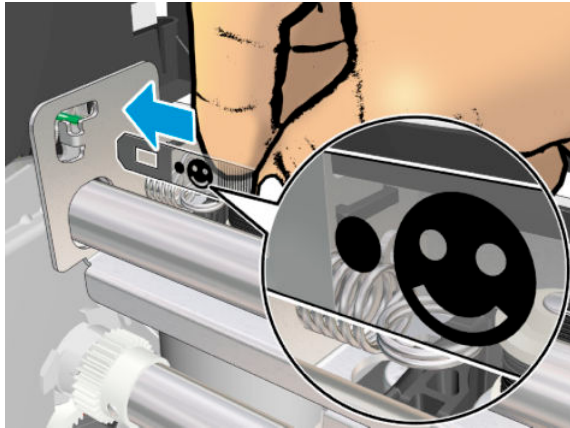

# Cutter Assembly

## Cutter Door F9A30-67006

### Removal

1. Remove one screw.

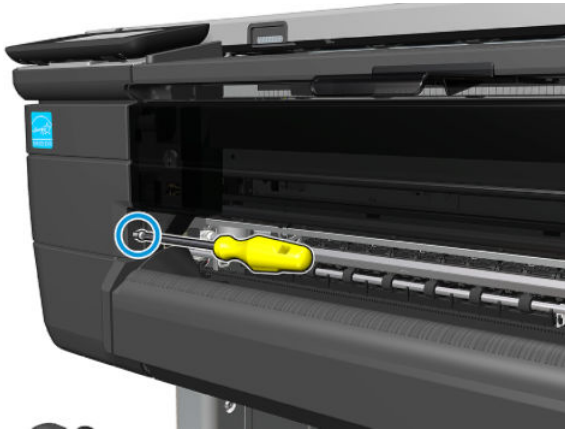

2. Open the Cutter Door.

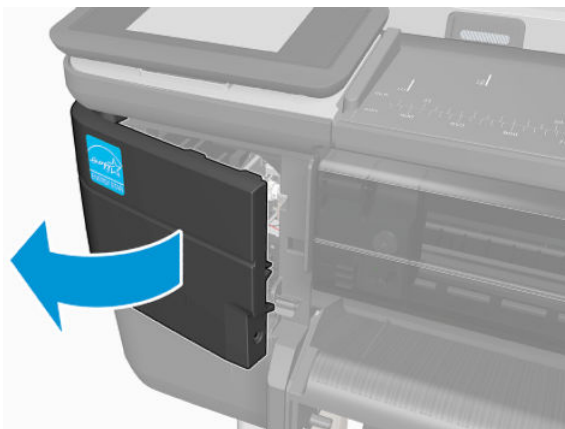

3. Unclip and remove the Cutter Door.

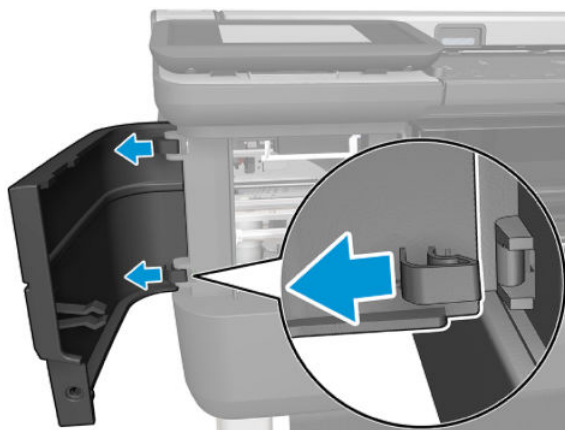

## Installation

- ▲ Install the Cutter Door by reversing the removal process.

## Cutter

### Removal

1. Switch off the printer and remove the power cable.
2. Follow the steps described in [Cutter flier on page 588](#).

## Cutter Bridge

The Cutter Bridge is attached to the front of the Carriage as shown below:

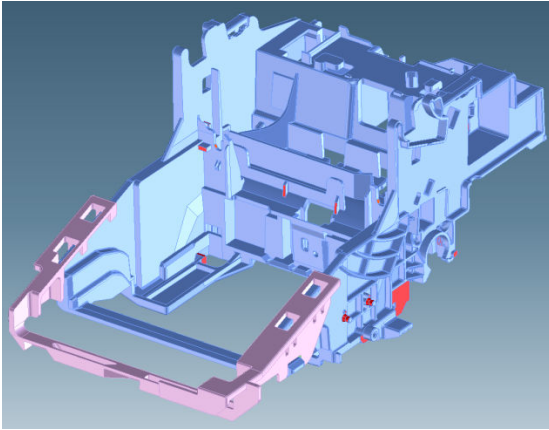

### Removal

1. Remove the Printhead Assembly, see [Replace the printhead on page 124](#).
2. Switch off the printer and remove the power cable.
3. **(MFP only)** Remove the Scanner Module, see [Scanner Module on page 505](#).
4. Ensure that the Carriage is in the center of the Platen, where you can easily access it.





5. Use the tool provided with the Cutter Assembly Kit to lever up the two prongs attaching the Cutter Bridge to the right-hand side of the Carriage.

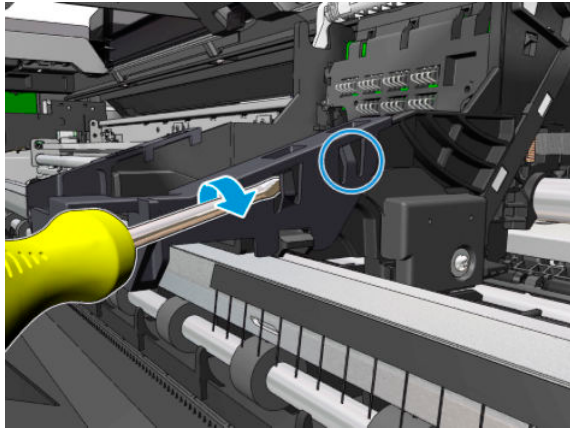

6. Use the tool again to lever up the two prongs attaching the Cutter Bridge to the left-hand side of the Carriage.

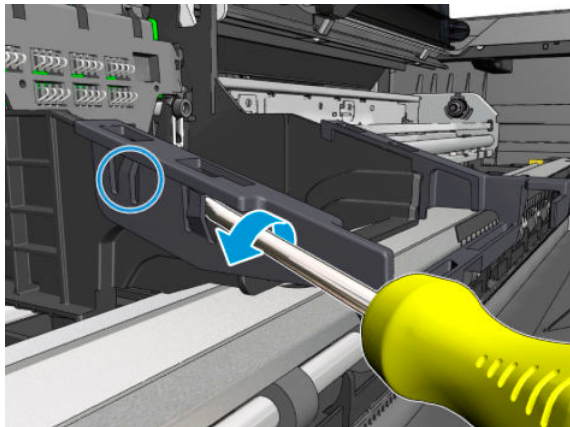

7. Remove the Cutter Bridge.

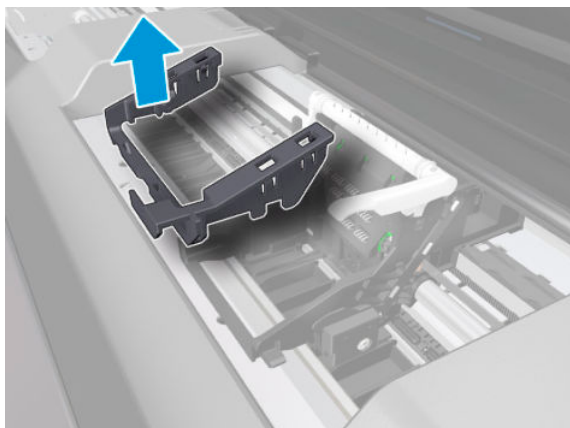

## Installation

1. Position the new Cutter Bridge above the Carriage and press down.

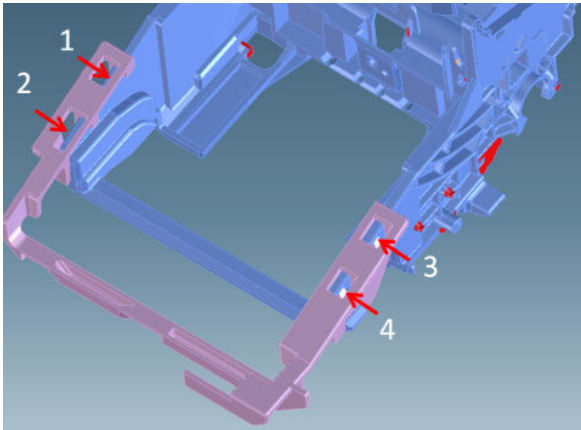

2. The Cutter Bridge is designed to fit over features of the Carriage.

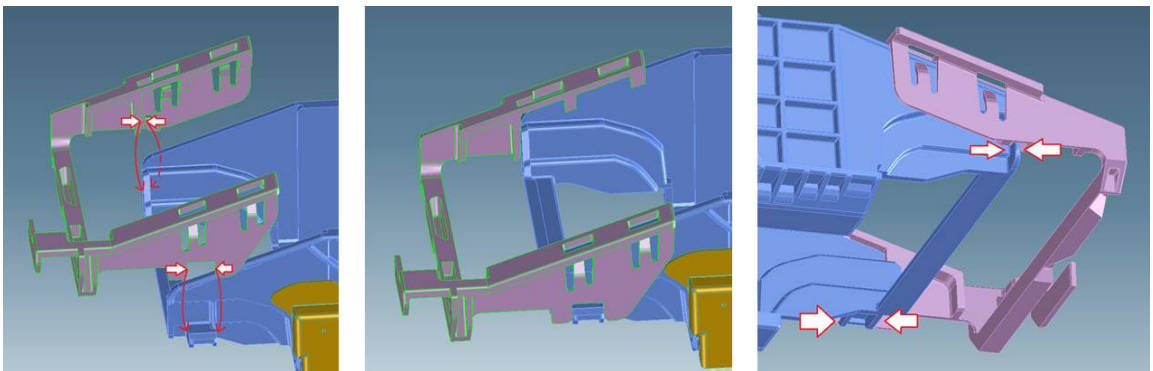

3. Use the tool provided with the Cutter Assembly Kit to press each of the four prongs attaching the Cutter Bridge to the Carriage, and make sure that all of them are correctly engaged; otherwise the Cutter may not work correctly.

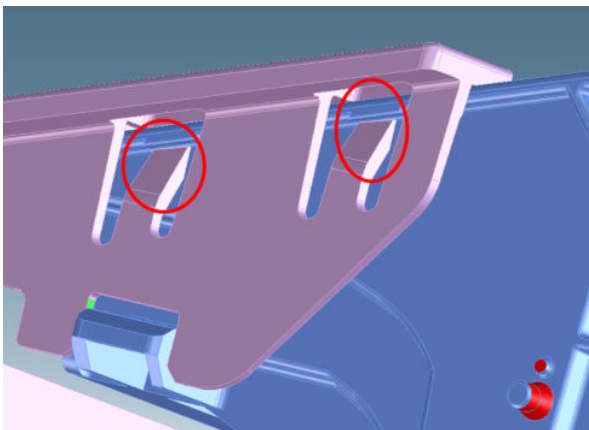

## Cutter Guide

### Removal

1. Switch off the printer and remove the power cable.
2. **(MFP only)** Remove the Scanner Module, see [Scanner Module on page 505](#).
3. Remove the Front Cover, see [Front Cover on page 261](#).
4. Remove the Cutter Door, see [Cutter Door F9A30-67006 on page 378](#).
5. Remove the Left Cover, see [Left Cover MFP SV Kit F9A30-67012 on page 268](#).
6. Remove the Right Cover, see [Right Cover MFP SV Kit F9A30-67011 on page 264](#).
7. Remove the Front Panel, see [Front Panel SFP F9A29-67008 on page 278](#).
8. Remove the Central Cover, see [Central Cover on page 284](#).
9. Remove the Output Tray, see [Output Tray on page 365](#).
10. Remove the Output Platen, see [Output Platen on page 370](#).
11. Remove the Cutter Assembly, see [Cutter Assembly on page 378](#).
12. Remove twelve T-10 screws for the 36 inch printer.

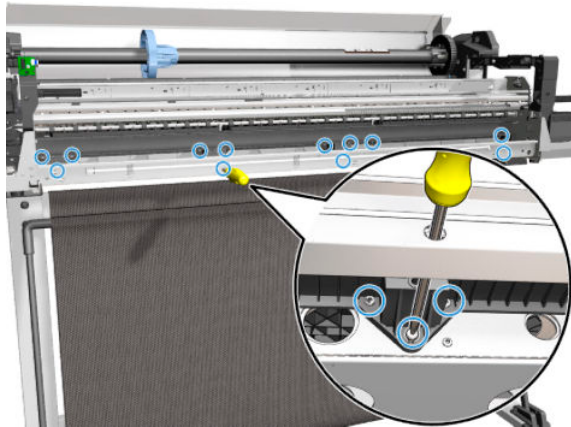

13. Rotate the Cutter Guide approximately 160°.

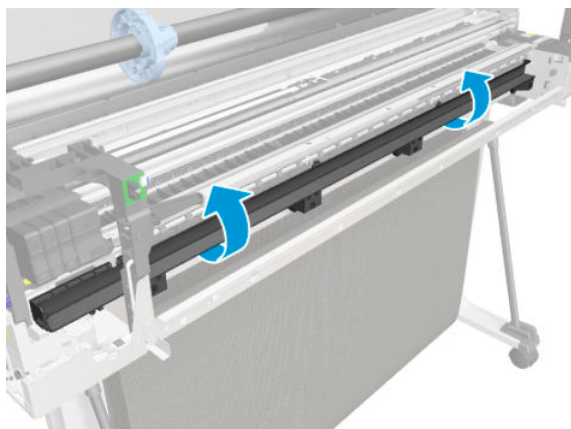

14. Slide the Cutter Guide to the right and remove it.

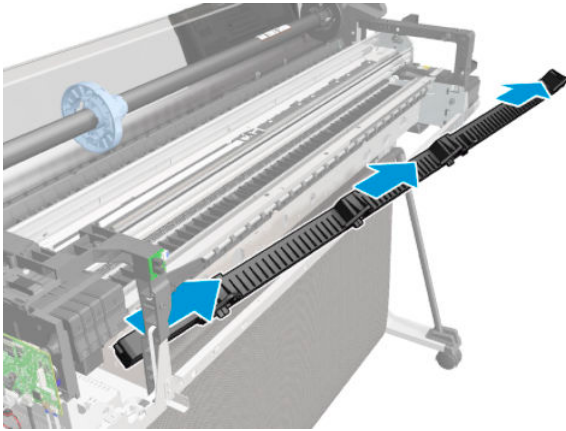

### Installation

- ▲ Install the Cutter Guide by reversing the removal process.

# Multi-Sheet Tray Sensor Assembly

## Removal

1. Remove the Left Cover, see [Left Cover MFP SV Kit F9A30-67012 on page 268](#).
2. Remove the Back Cover, see [Back Cover on page 275](#).
3. Disconnect the cable from the main PCA.

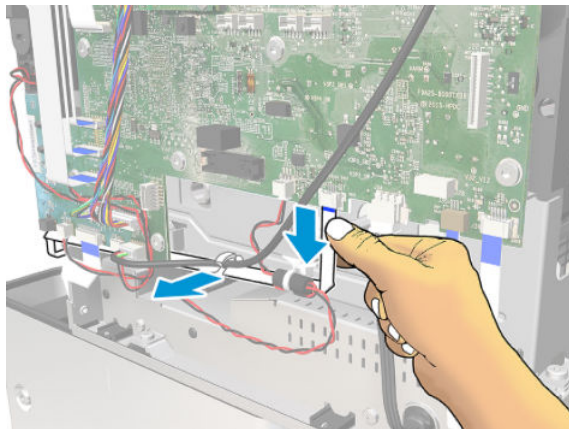

4. Unroute the cable.

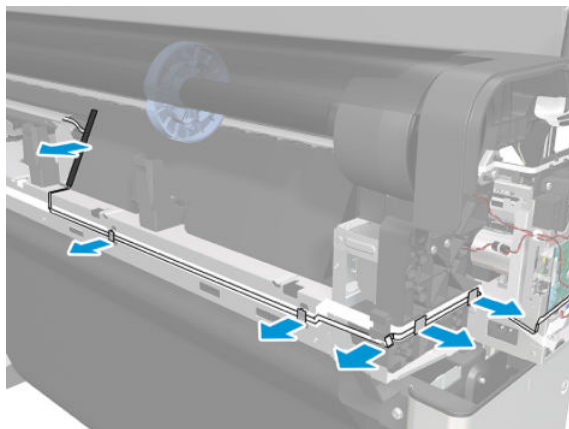

5. Close the Scanner and open the Roll Cover.

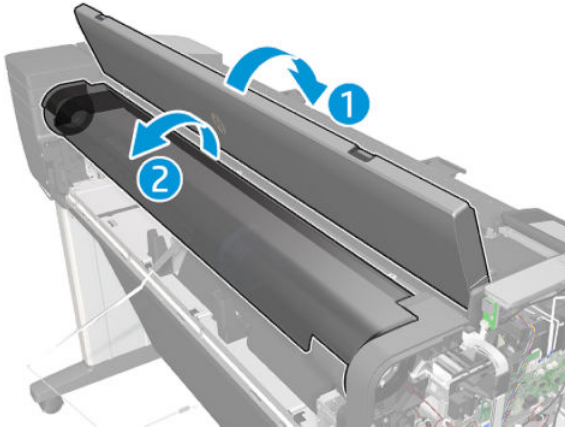

6. Remove the Spindle.

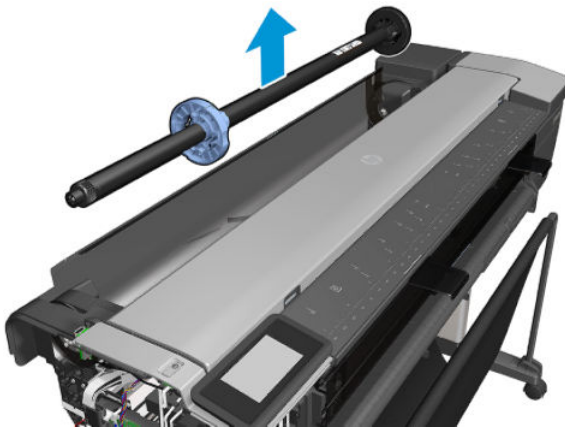

7. Remove one screw.



8. Remove the cover partially and remove two screws.

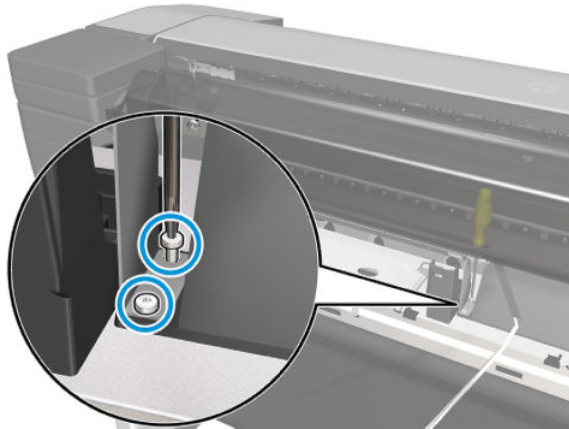

9. Remove the Multi-sheet Tray Assembly.

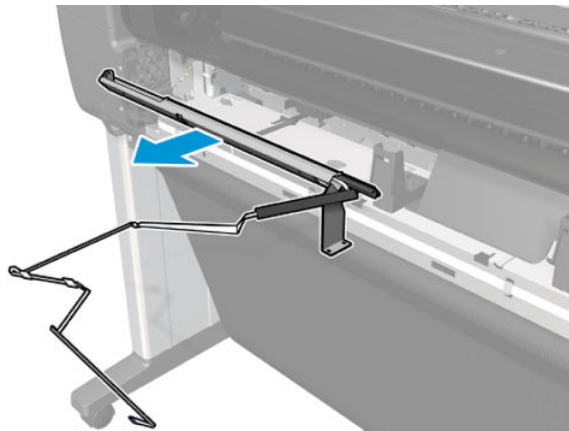

### Installation

- ▲ Install the Multi Sheet Tray Sensor Assembly by reversing the removal process.

# Out-Of-Paper Sensor

## Removal

1. Switch off the printer and remove the power cable.
2. Remove the Multi-Sheet Tray, see [Multi-Sheet Tray Assembly on page 367](#).
3. Locate the Out-Of-Paper Sensor.



4. Unclip the Out-Of-Paper Sensor FFC Cover.

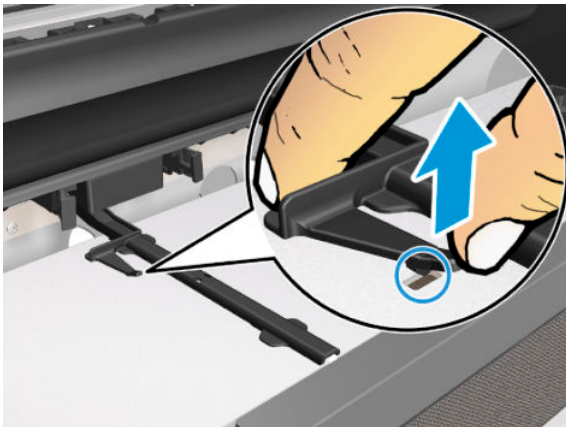



5. Slide the Out-Of-Paper Sensor FFC Cover.

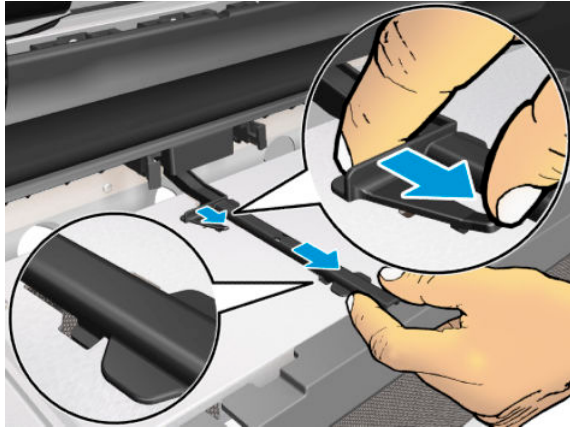

6. Lift up (1) the Out-Of-Paper Sensor FFC Cover and slide it to the left (2).

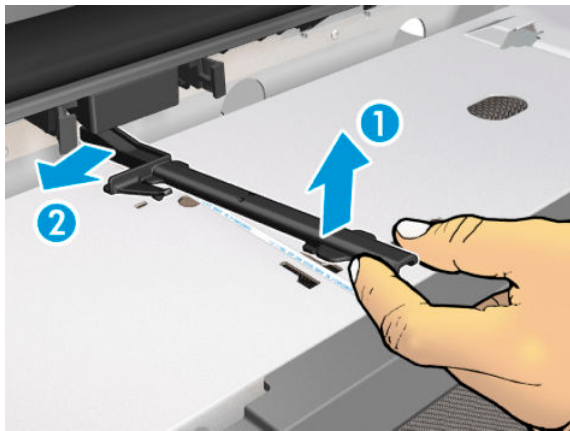

7. Press the retaining clips of the Out-Of-Paper Sensor Assembly.

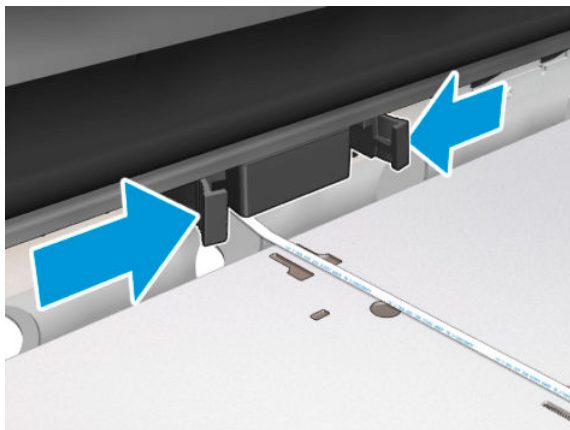

8. Slide out the Out-Of-Paper Sensor Assembly.

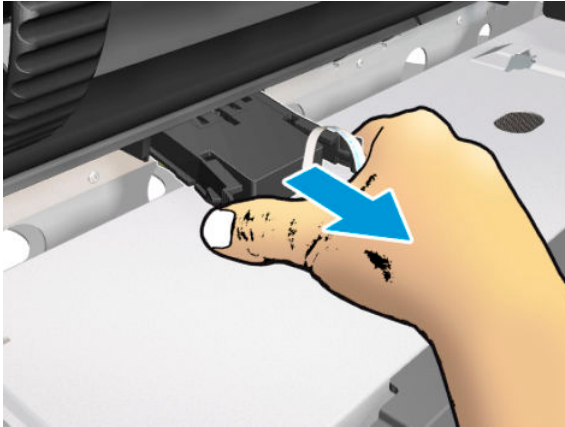

9. Turn over the Out-Of-Paper Sensor Assembly to get better access to the connector.

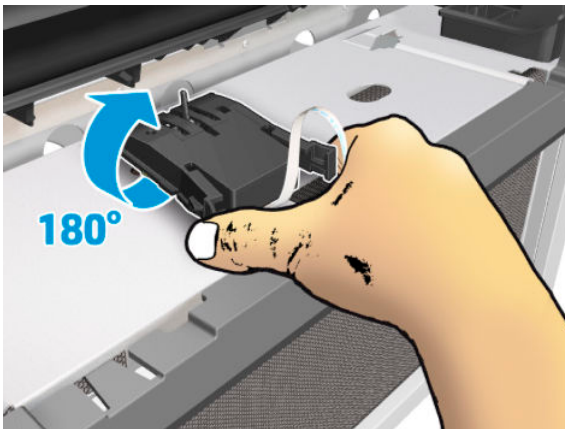

10. Disconnect the Out-Of-Paper Sensor cable.

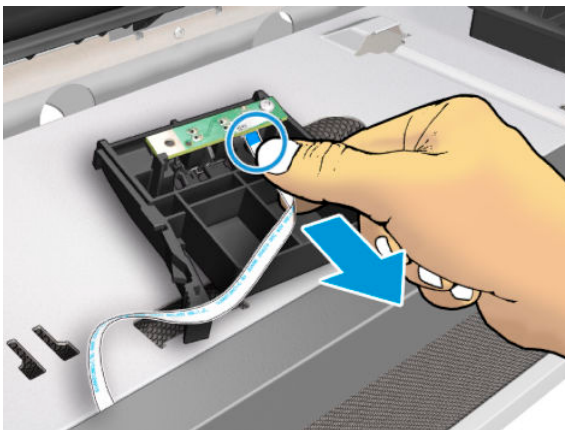

11. Remove the Out-Of-Paper Sensor Assembly.

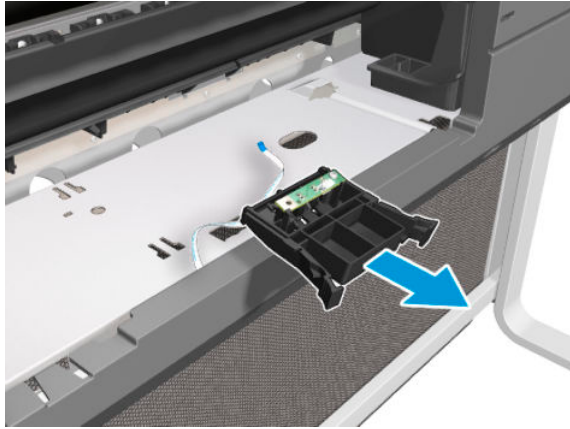

### Installation

- ▲ Install the Out-Of-Paper Sensor by reversing the removal process.

# Out-Of-Paper Sensor Cable

## Removal

1. Remove the Front Cover, see [Front Cover on page 261](#).
2. Remove the Cutter Door, see [Cutter Door F9A30-67006 on page 378](#).
3. Remove the Left Cover, see [Left Cover MFP SV Kit F9A30-67012 on page 268](#).
4. Remove the Right Cover, see [Right Cover MFP SV Kit F9A30-67011 on page 264](#).
5. Remove the Back Cover, see [Back Cover on page 275](#).
6. Remove the Out-Of-Paper Sensor, see [Out-Of-Paper Sensor on page 388](#).
7. Unclip the locator FFC.

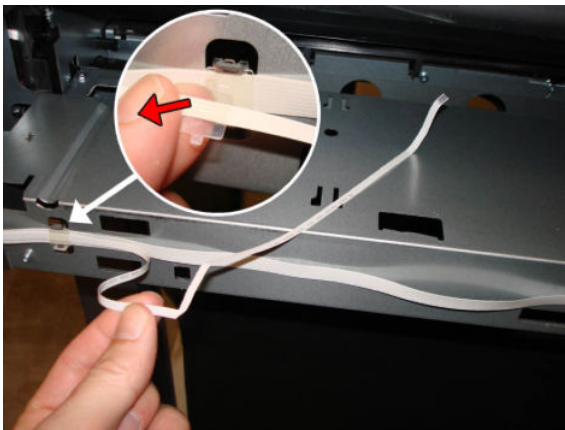

8. Disconnect the Out-Of-Paper Sensor Cable from the Bundle Board.

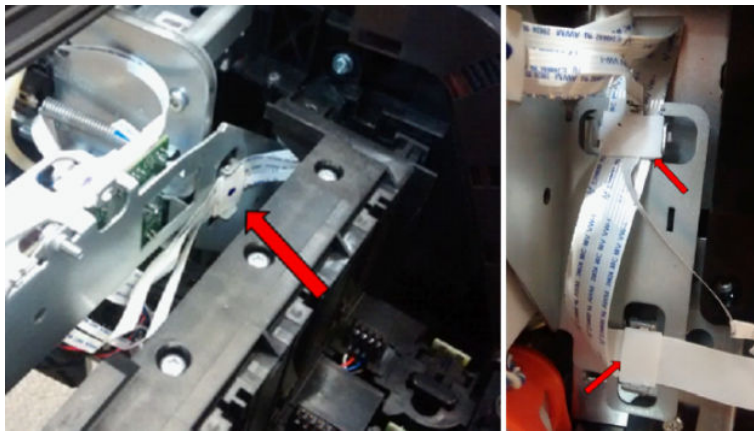
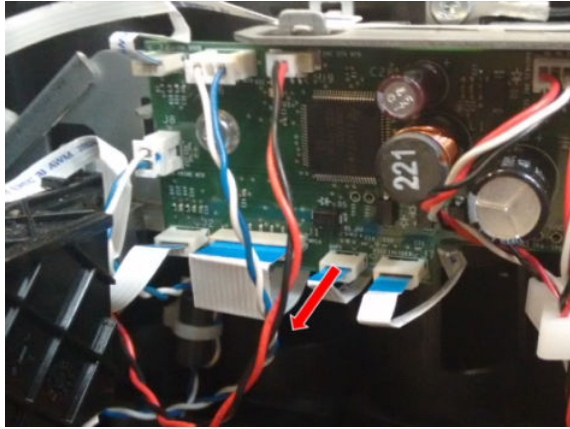

9. Unroute the Out-Of-Paper Sensor Cable through the hook.

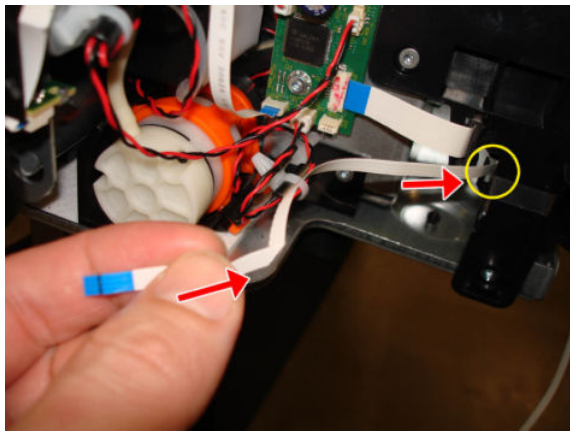

10. Remove the Out-Of-Paper Sensor Cable.

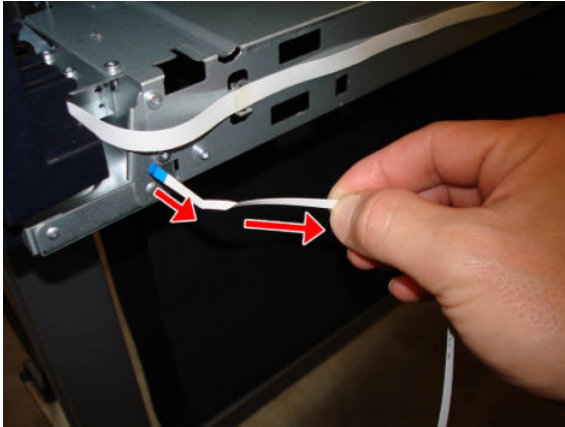

### Installation

- ▲ When you pass the Out-Of-Paper Sensor Cable through the hook, make sure that the blue end of the cable is facing you.

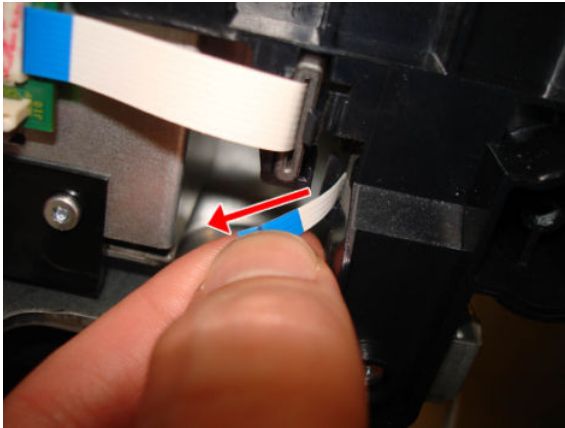

# Output Tray Sensor Assembly

## Removal

1. Remove the Front Cover, see [Front Cover on page 261](#).
2. Locate the Output Tray Sensor Assembly.



3. Remove two T-10 screws.

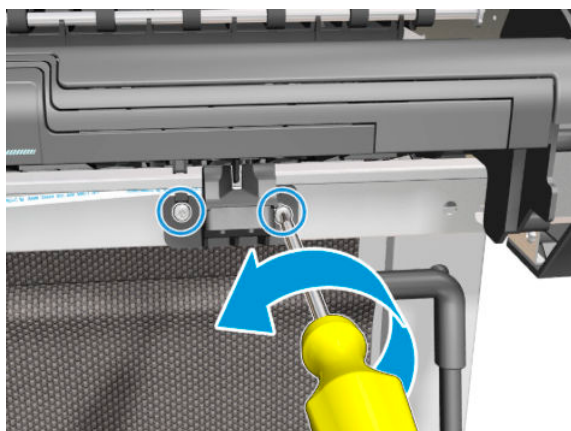

4. Detach the Output Tray Sensor from the two locator pins.

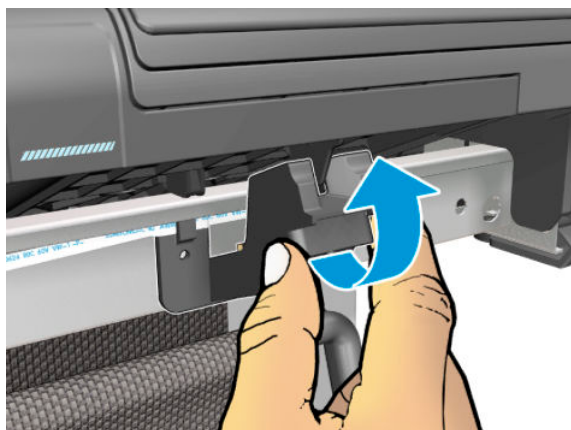

5. Remove the Output Tray Sensor Assembly in the direction shown below.

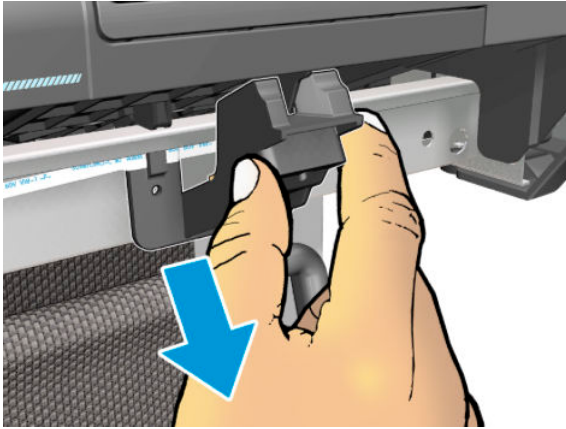

6. Remove the Output Tray Sensor Cable from the retainer clip in the assembly.

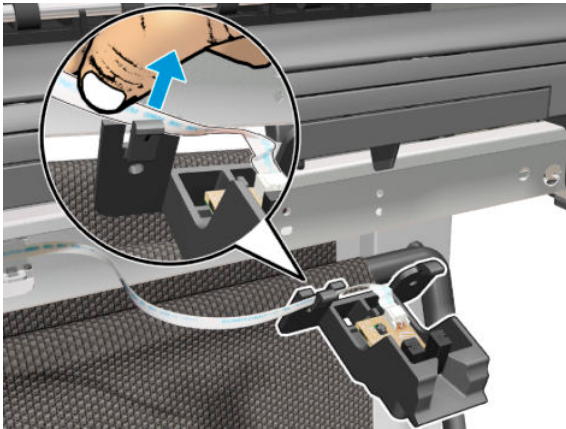

7. Disconnect the flat cable (Output Tray FFC).



## Installation

1. When installing the Output Tray Sensor Cable, ensure the orientation of the cable is correct as you install it.



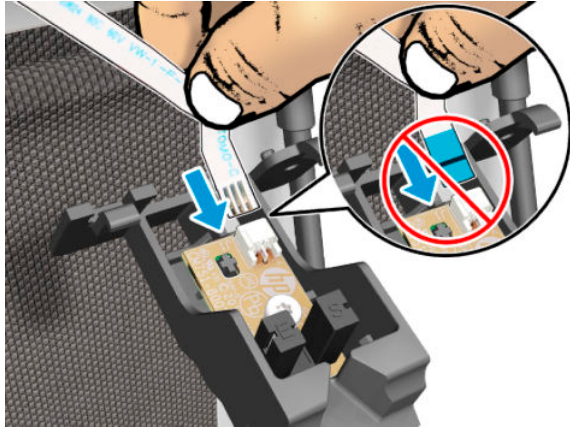

2. Attach the two pins of the Output Tray Sensor to the front of the printer.

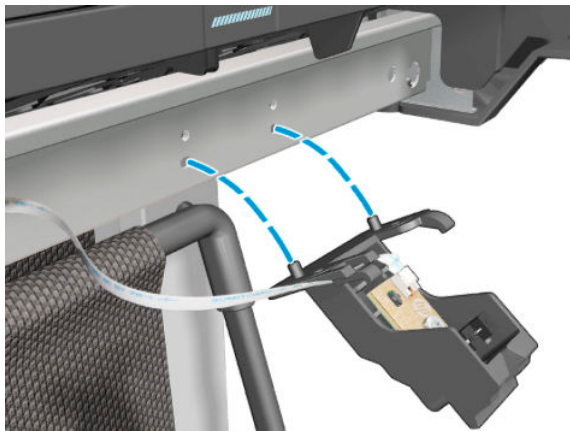

3. Make sure the Output Tray Sensor is mounted correctly.

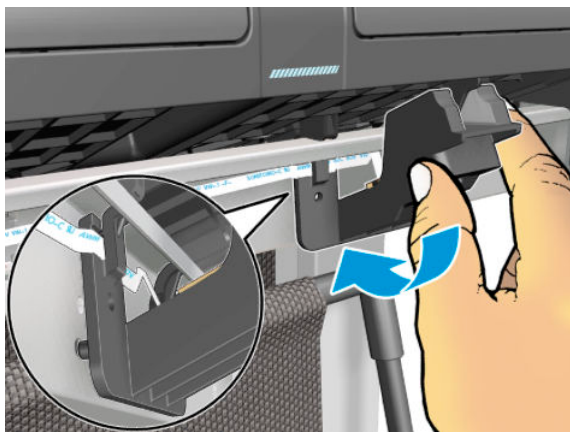

# Output Tray Extender Sensor Cable

## Removal

1. Remove the Front Cover, see [Front Cover on page 261](#).
2. Remove the Cutter Door, see [Cutter Door F9A30-67006 on page 378](#).
3. Remove the Left Cover, see [Left Cover MFP SV Kit F9A30-67012 on page 268](#).
4. Remove the Output Tray Sensor, see [Output Tray Sensor Assembly on page 395](#).
5. Unclip the locator FFC from the right of the Front Cross Beam.

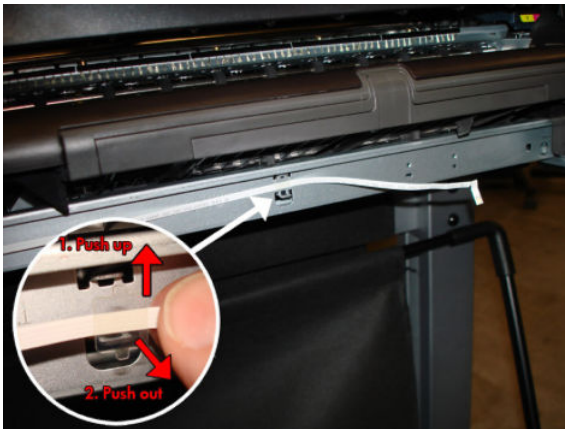

6. Unclip the locator FFC from the middle of the Front Cross Beam.

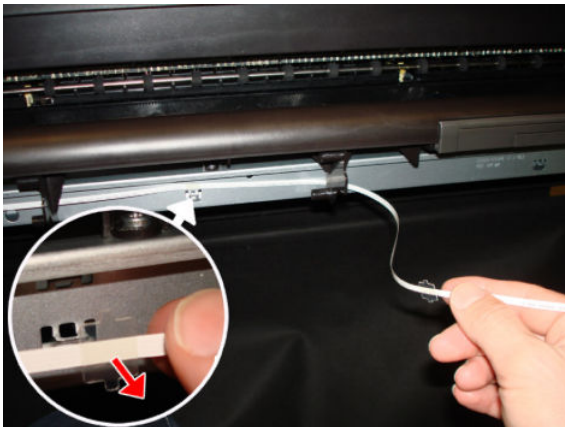

7. Unclip the locator FFC from the left of the Front Cross Beam.

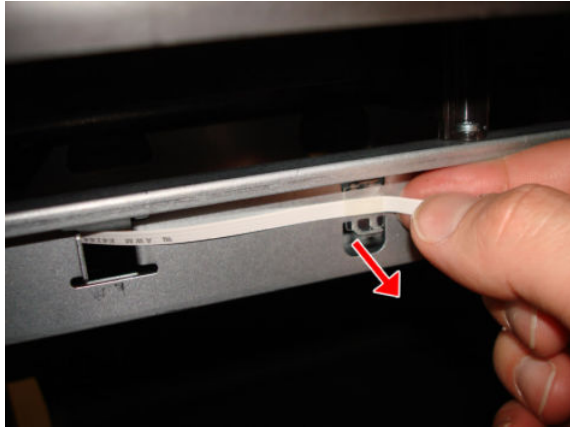

8. Disconnect the Output Tray Extender Sensor Cable from the Main PCA.

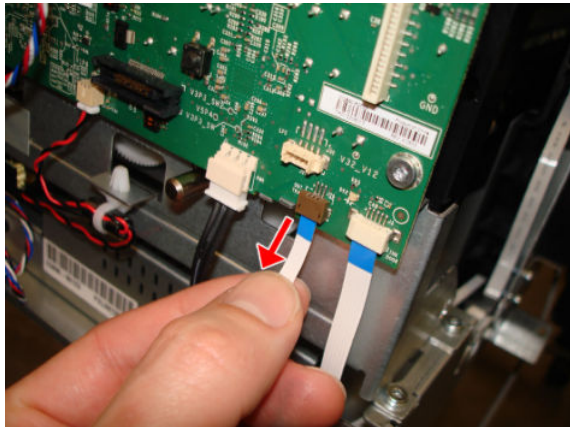

9. Unroute the flat cable carefully.

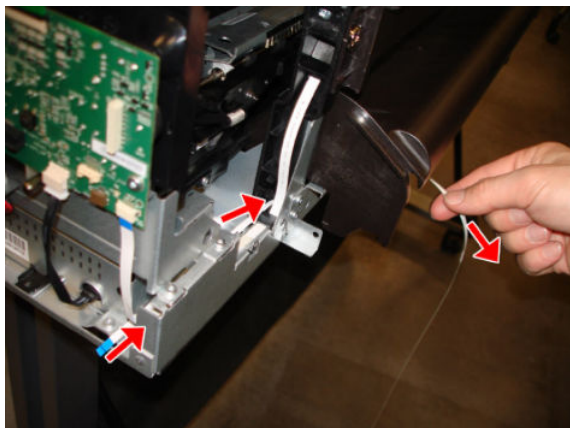

10. Remove the Output Tray Extender Sensor Cable.

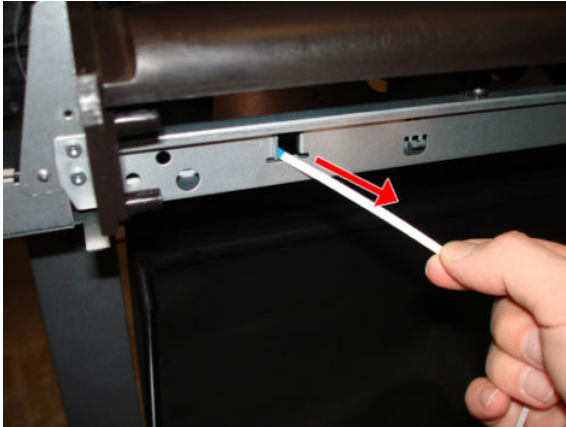

### Installation

1. Pass the Output Tray Extender Sensor Cable through the hole of the Front Cross Beam.

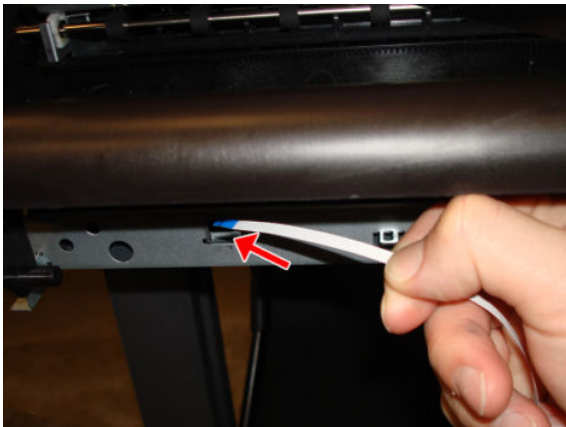

2. Pass the Output Tray Extender Sensor Cable through the hole of the left arch. **Important:** The blue color should be facing you.

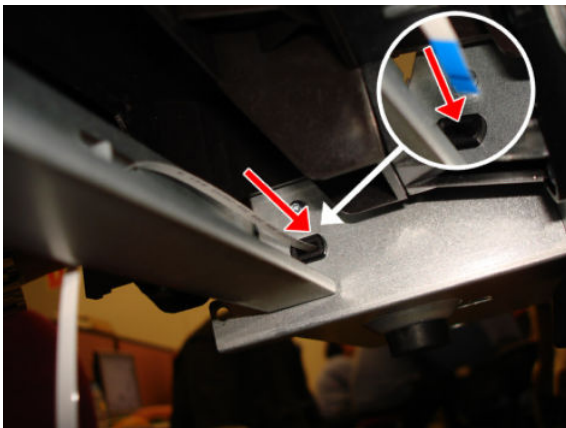

3. Slide the Output Tray Extender Sensor Cable through the hole of the left arch.

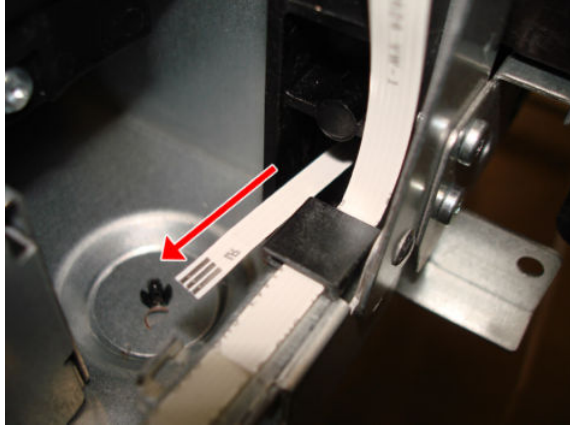

# Carriage Line Sensor

## Removal

1. Switch off the printer and remove the power cable.
2. Remove the Front Cover, see [Front Cover on page 261](#).
3. Remove the Right Cover, see [Right Cover MFP SV Kit F9A30-67011 on page 264](#).
4. Make sure the Service Station and Carriage are located in the right position.

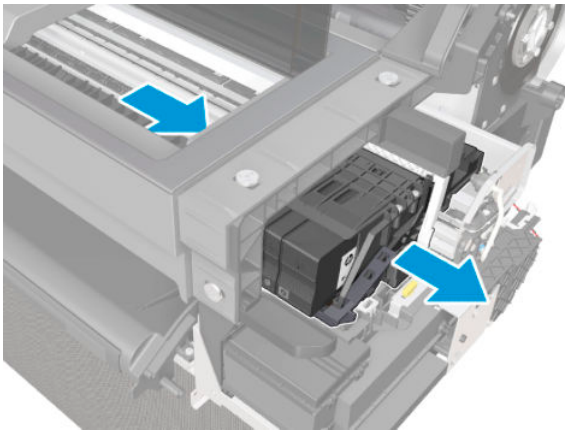

5. Detach the right side of the Cover PCA Carriage.

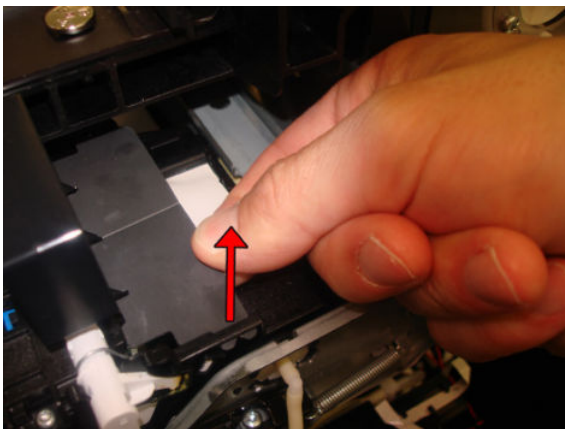

6. Remove the Cover PCA Carriage.

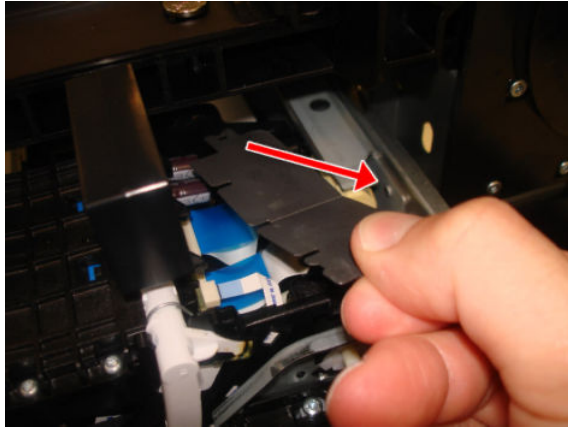

7. Disconnect the flat cable.

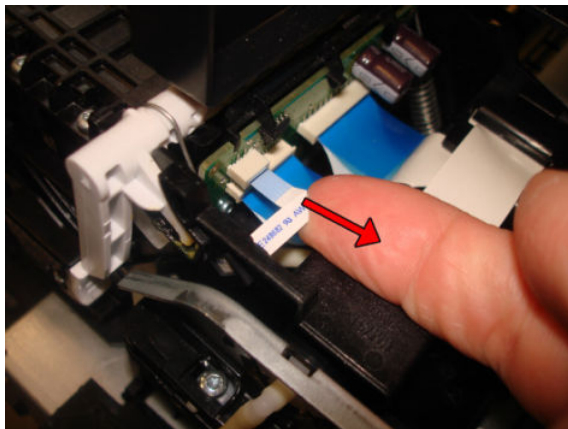

8. **Important:** If the Carriage is in the capped position, move the Service Station gear clockwise to uncap it.

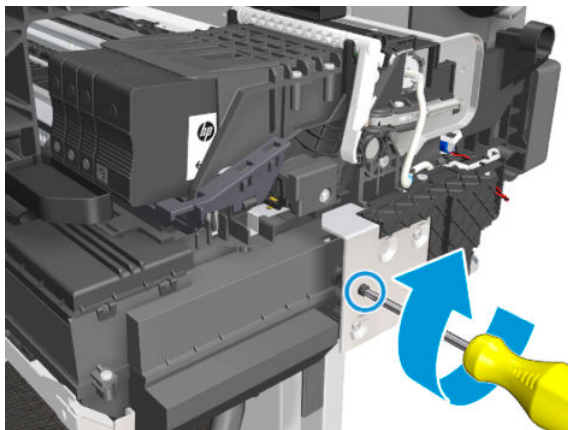

9. Move the Carriage slightly to allow access to the Carriage Line Sensor, maintain a separation of 4 cm.

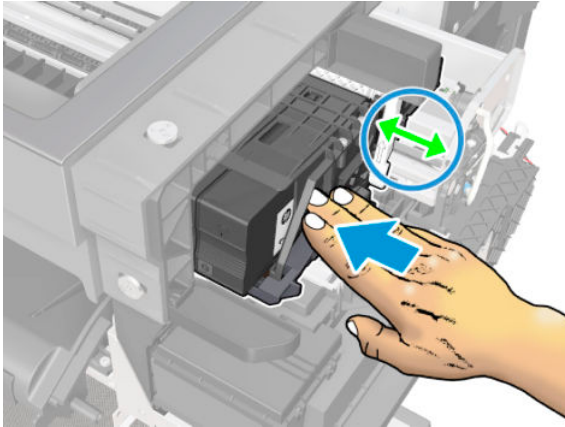

10. Remove one T-6 screw.

**⚠ CAUTION:** Make sure that the screw does not fall down into the Service Station.

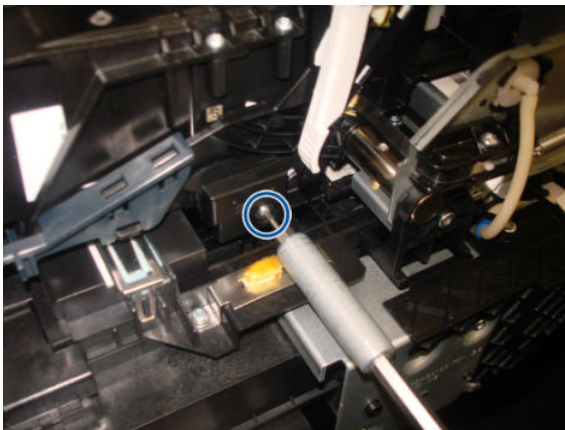

11. Open the Carriage latch upwards to allow access to the Carriage Line Sensor.

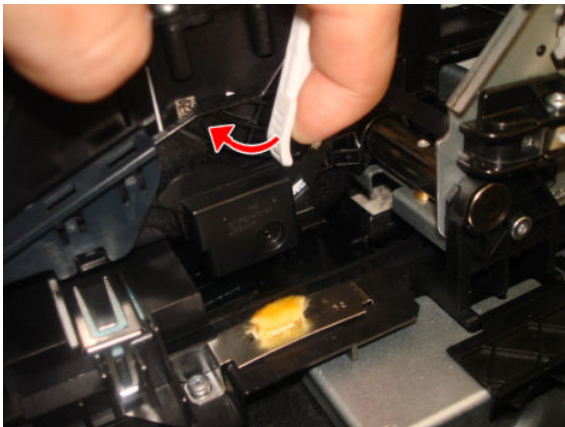



12. Detach the Line Sensor from the Carriage.

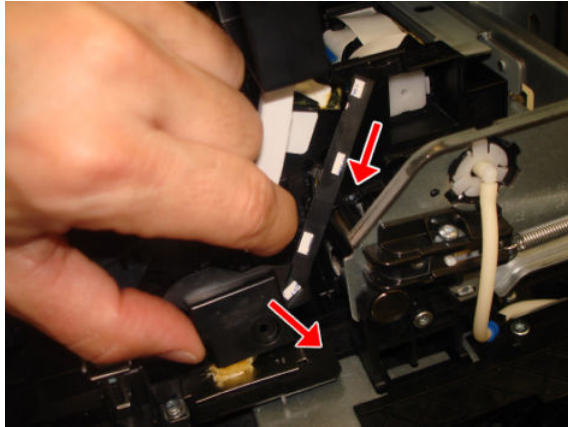

13. Remove the Carriage Line Sensor.

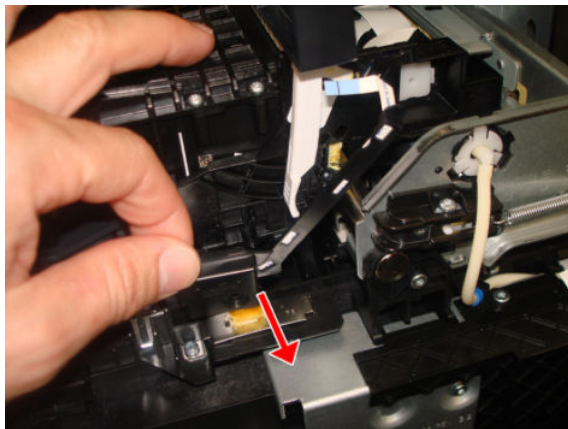

## Installation

1. Make sure to introduce the end of the Carriage Line Sensor into the hole in the Carriage.

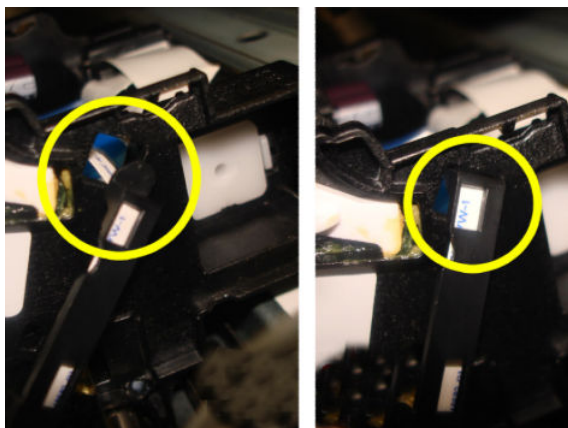

2. Before putting the covers back on, clean the Carriage Line Sensor. See [Clean the Carriage Line Sensor on page 530](#).
3. Make sure the carriage latch is pointing upwards, locking the PHA correctly in position.

# Bundle Board

## Removal

1. Switch off the printer and remove the power cable.
2. Remove the Front cover, see [Front Cover on page 261](#).
3. Remove the Right Cover, see [Right Cover MFP SV Kit F9A30-67011 on page 264](#).
4. Disconnect four motor cables.

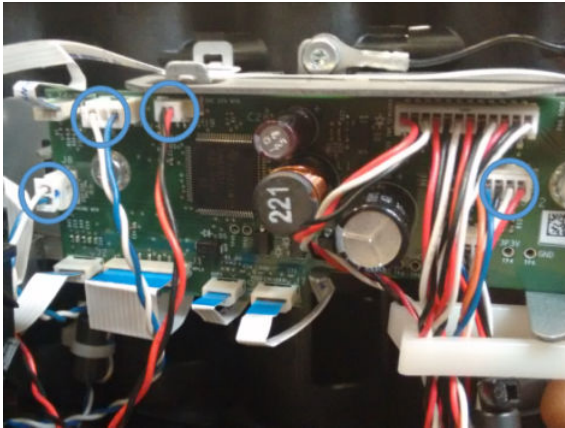

5. Disconnect six FFC (flat flexible cables) from the Bundle Board.

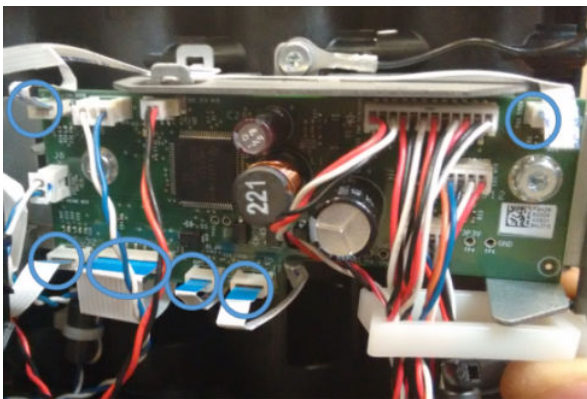

6. Remove two sensor cables.

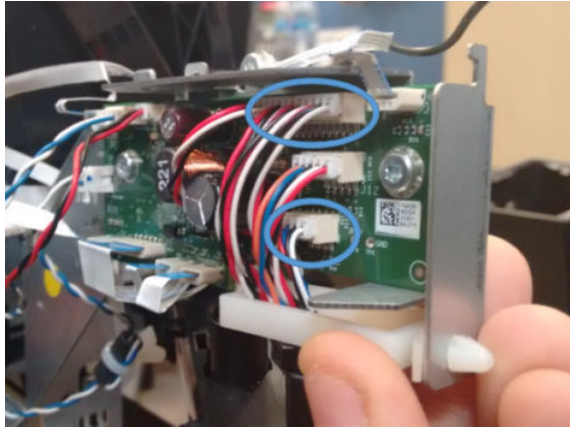

7. Remove two T-10 screws.

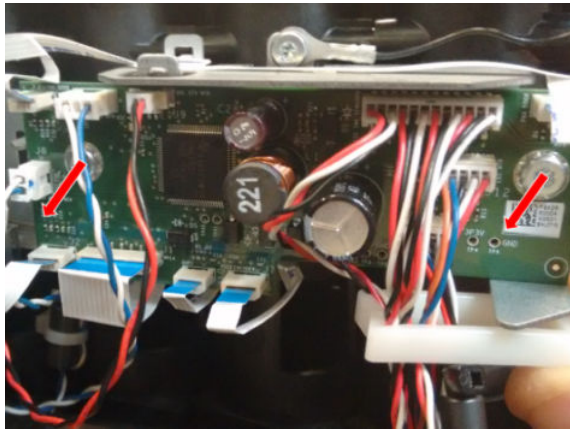

**⚠ CAUTION:** Take care not to drop the Printer Bundle Board inside the stand leg, it is a good idea to cover the gap.

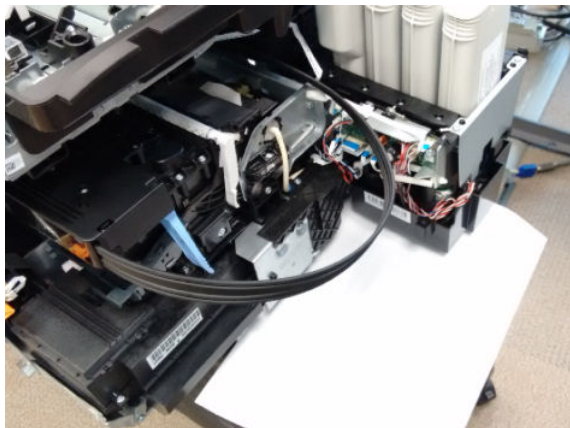

## Installation

- ▲ Install the Bundle Board by reversing the removal process.

## Bundle Board FFC cable

### Removal

1. Switch off the printer and remove the power cable.
2. Remove the Front Cover, see [Front Cover on page 261](#).
3. Remove the Cutter Door, see [Cutter Door F9A30-67006 on page 378](#).
4. Remove the Left Cover, see [Left Cover MFP SV Kit F9A30-67012 on page 268](#).
5. Remove the Right Cover, see [Right Cover MFP SV Kit F9A30-67011 on page 264](#).
6. Remove the Back Cover, see [Back Cover on page 275](#).
7. Disconnect the FFC cable from the Bundle Board.

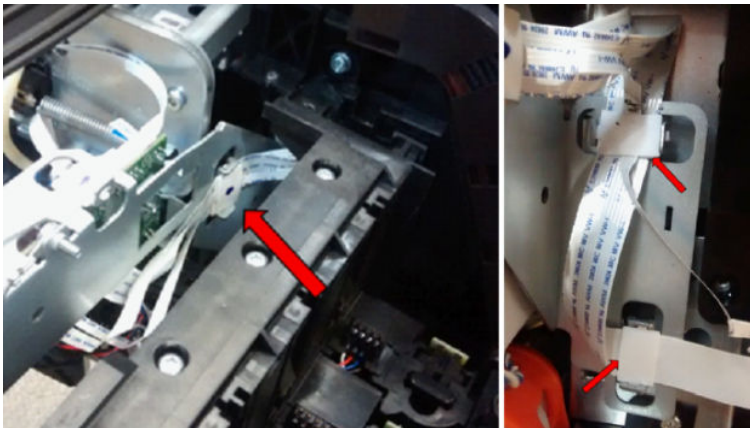
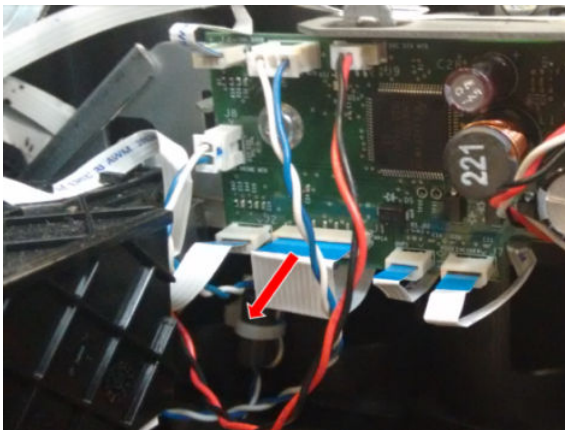

8. Unclip the two locators FFC, by first pushing up and pushing out.

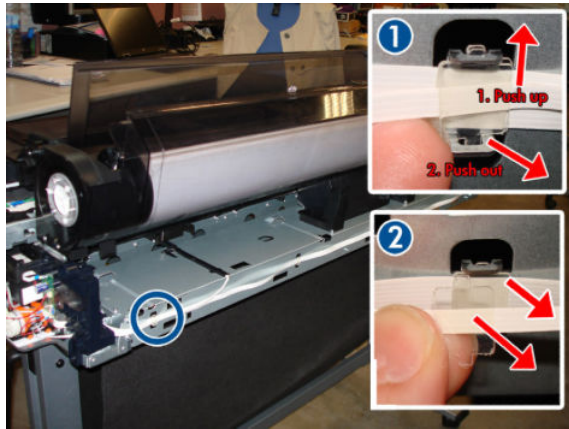

9. Unroute the Bundle Board Cable FFC.

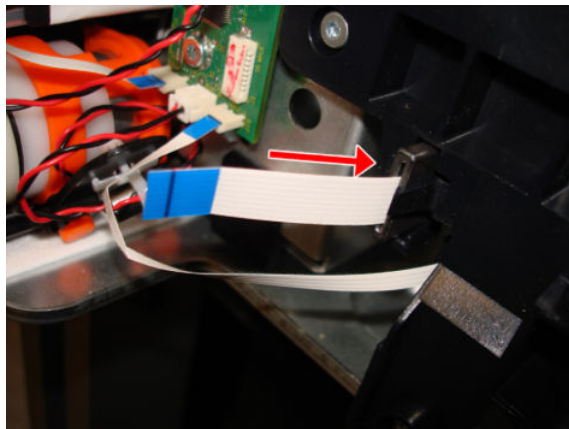

10. Unclip the locators FFC.

- 4 clips in the 36 inch printer



11. Carefully remove the FFC from the hook of the left arch.

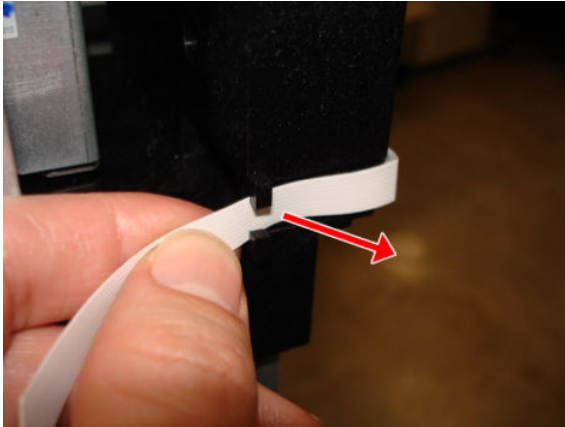

12. Carefully remove the FFC from the 2 hooks of the left arch.

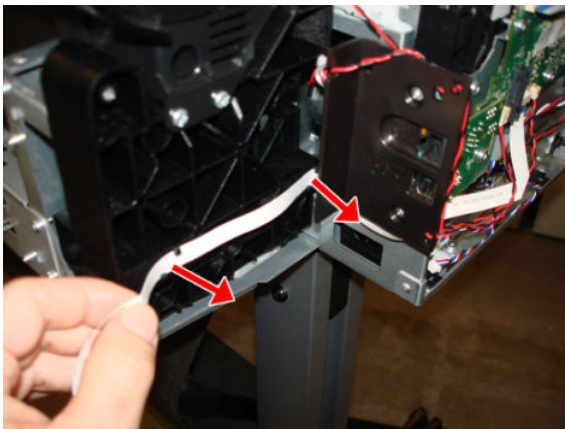

13. Disconnect the Bundle Board cable FFC from the Main PCA and remove it.

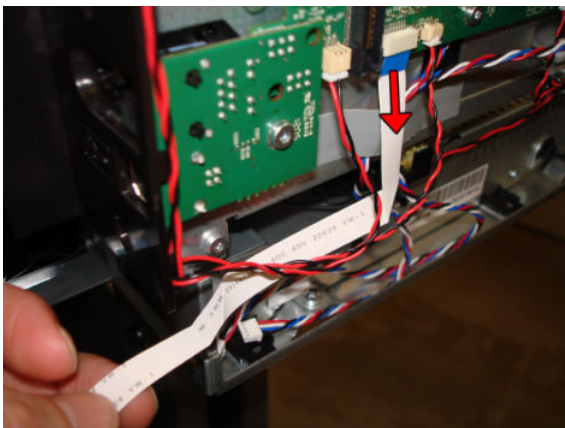

## Installation

1. When re-installing the Bundle FFC into the hooks of the left arch, orient the FFC inclined as shown below. Make sure to assemble the Bundle Ferrite in the same position close to the Bundle Board.

 **NOTE:** When re-installing the Bundle FFC, hook each clamp first on the upper clip and then push on the bottom area.

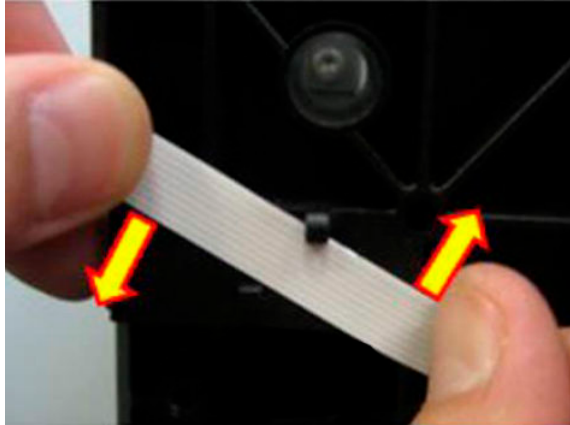

2. Unclip to remove the ferrite of the right arch.



3. Remove the ferrite.

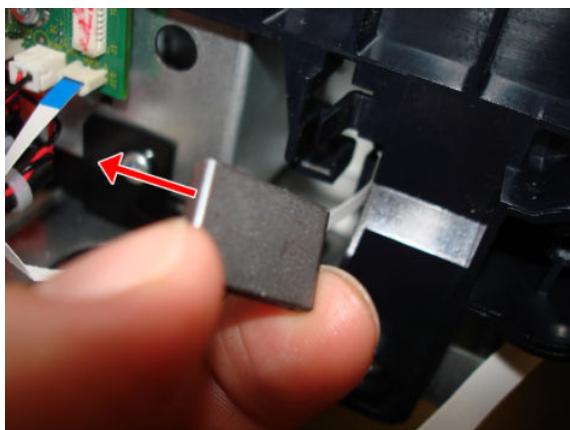

4. Route the Bundle FFC.

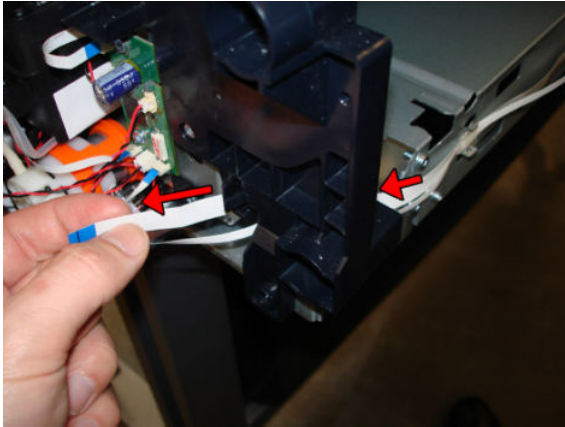

5. Re-install the Bundle FFC in exactly the same place where the ferrite was.

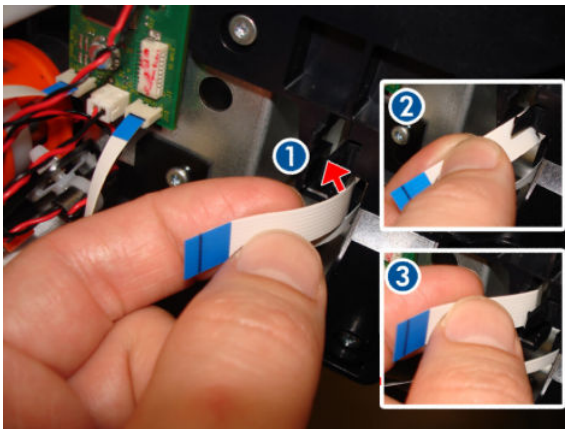

6. Pass the ferrite through the FFC.

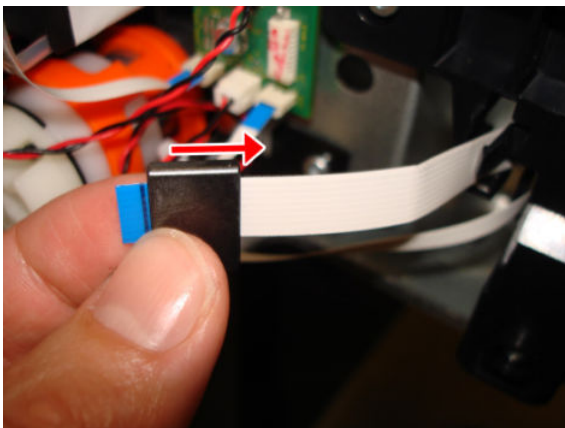



7. Attach the ferrite to the right arch.

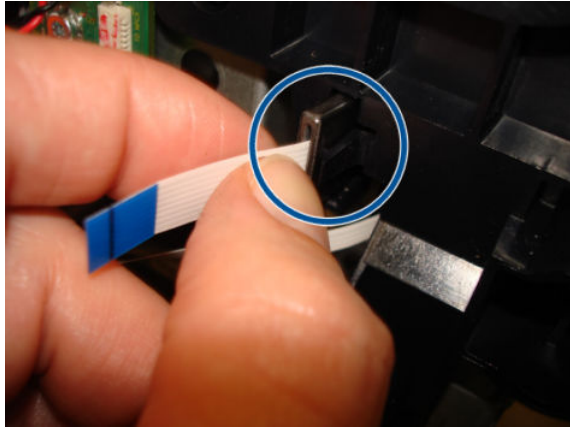

8. Route the cable through the FFC locators.

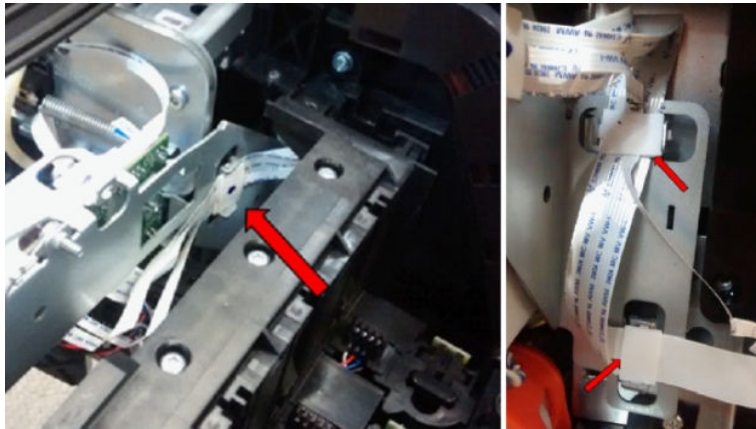

# Pinchwheels

## Removal

1. Switch off the printer and remove the power cable.
2. **(MFP only)** Remove the Scanner Module, see [Scanner Module on page 505](#).
3. Remove the Front Cover, see [Front Cover on page 261](#).
4. Remove the Cutter Door, see [Cutter Door F9A30-67006 on page 378](#).
5. Remove the Left Cover, see [Left Cover MFP SV Kit F9A30-67012 on page 268](#).
6. Remove the Right Cover, see [Right Cover MFP SV Kit F9A30-67011 on page 264](#).
7. Remove the Front Panel, see [Front Panel SFP F9A29-67008 on page 278](#).
8. Remove the Central Cover, see [Central Cover on page 284](#).
9. Remove the Back Cover, see [Back Cover on page 275](#).
10. Remove the Upper-Roll Paper Guide, see [Upper-Roll Paper Guide on page 289](#).
11. If the damaged Pinchwheels are in the zone indicated in green below, remove the Aerosol Shields and go to step [18](#).

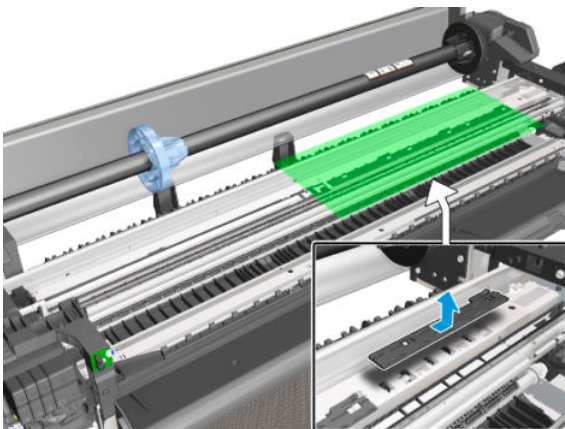

If the damaged Pinchwheels are in the zone indicated in green below, continue with the next steps.

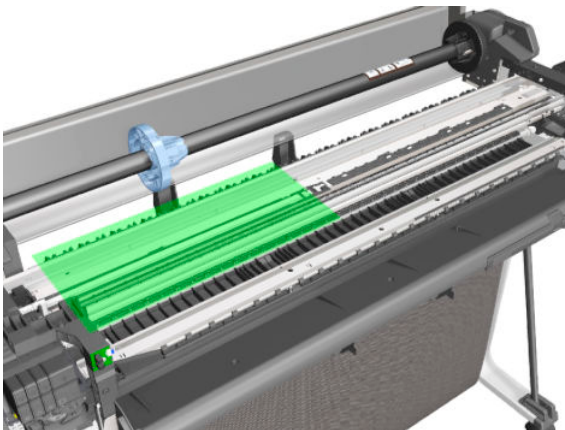

12. Uncap the Carriage, move it to the right, and leave it in the position indicated below.

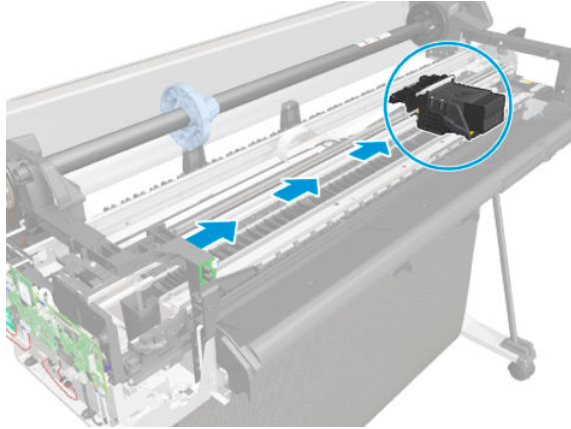

13. Disconnect the two flat trailing cables from the Main PCA.

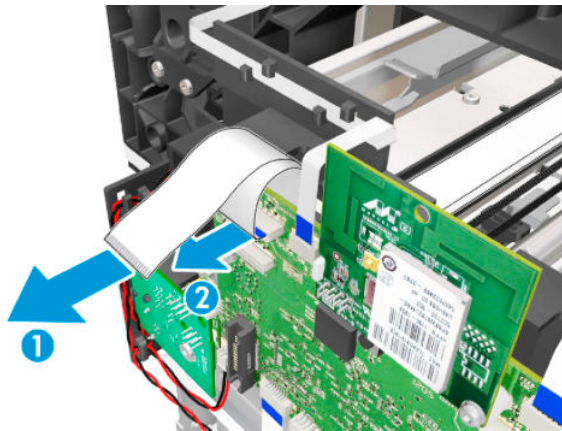

14. Remove one T-10 screw.

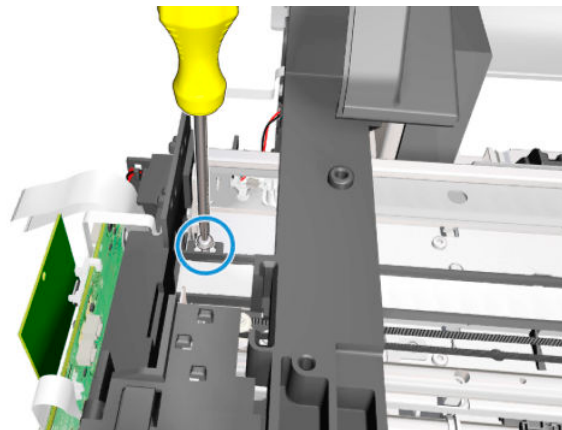

15. Detach the flex retainer assembly from the backbone.

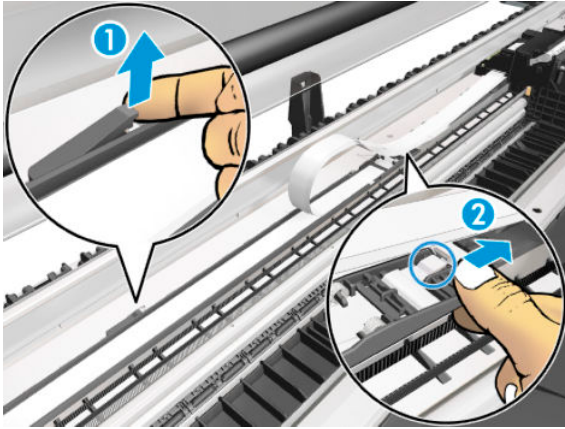

16. Slide the flex retainer with the trailing cable to the right. Be careful not to damage the trailing cable.

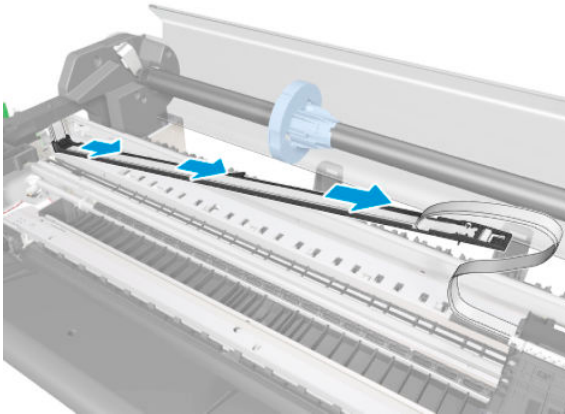

17. Leave the flex retainer with the trailing cable in the position shown below.

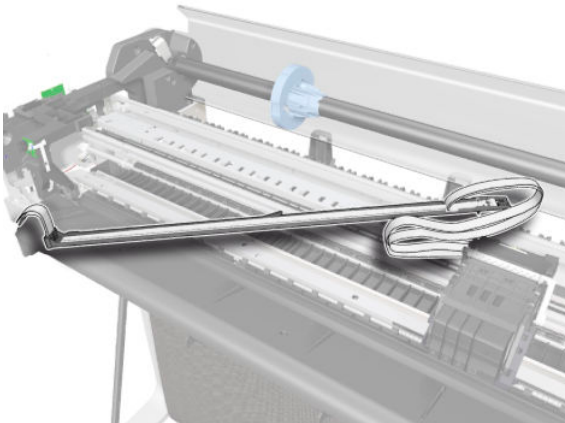

18. Loosen the screws that secure the Pinchwheels.

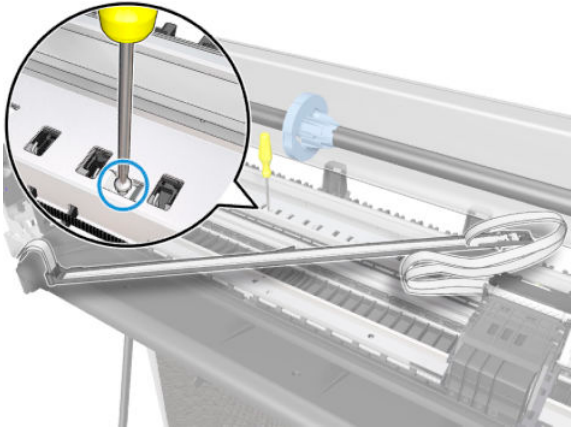

19. Locate the tool needed to detach the springs.



20. Detach the left end of the Pinchwheels.

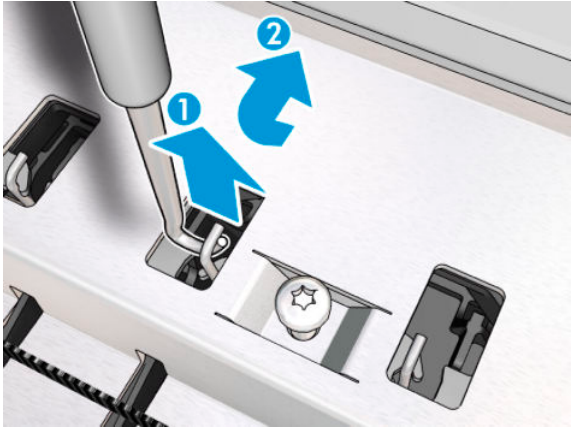

21. Detach the right end of the Pinchwheels.

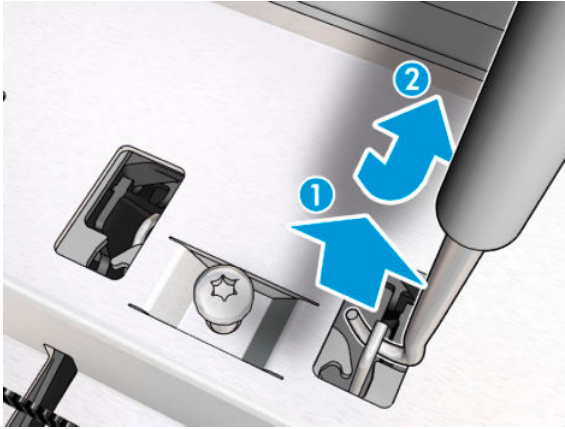

22. Remove one T-10 screw.

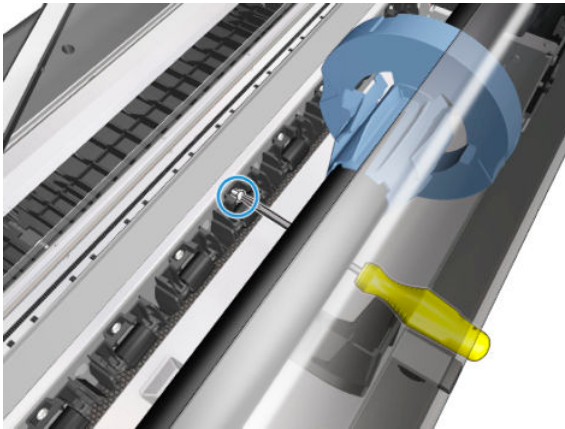

23. Remove the Pinchwheels.

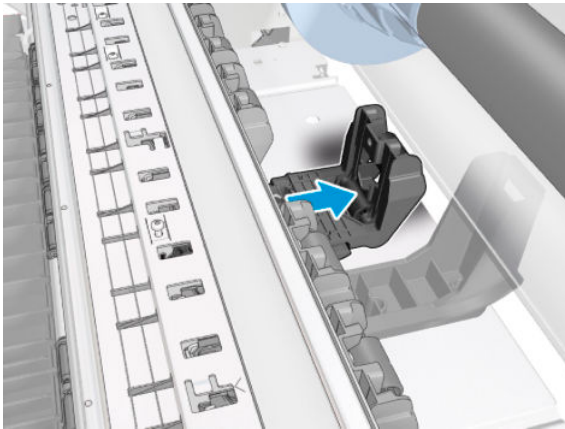

## Installation

1. Make sure that the new Pinchwheels are properly aligned (1). Then tighten the screw (2).

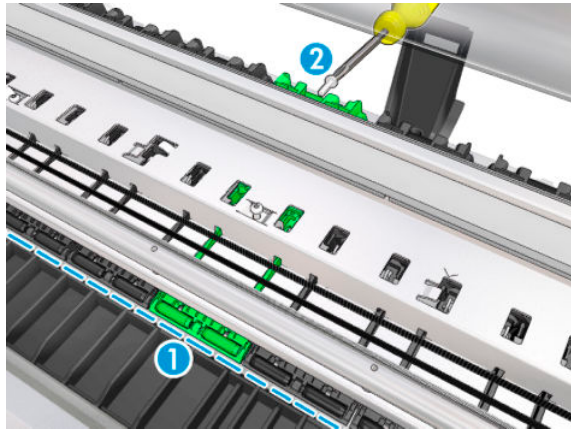

2. Attach the spring to the hook by pushing with the tool provided.



# Left Spittoon

## Removal

1. Switch off the printer and remove the power cable.
2. Remove one screw.

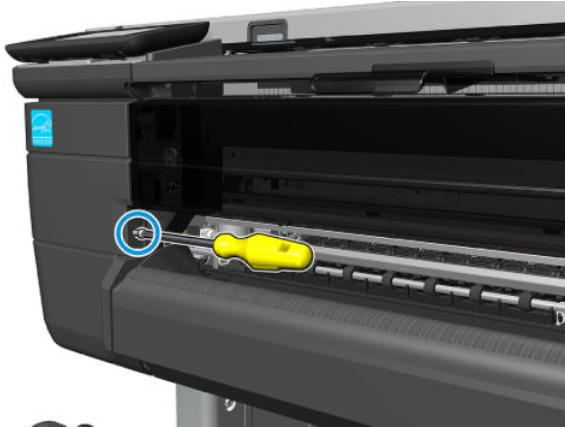

3. Open the Cutter Door.



4. Slide the Cutter to the right.

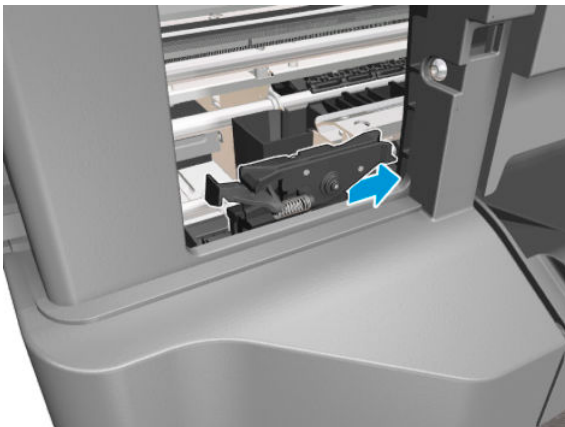



5. Unclip the flange of the Left Spittoon (1). Maintain it in the unclipped position and slide it up (2).

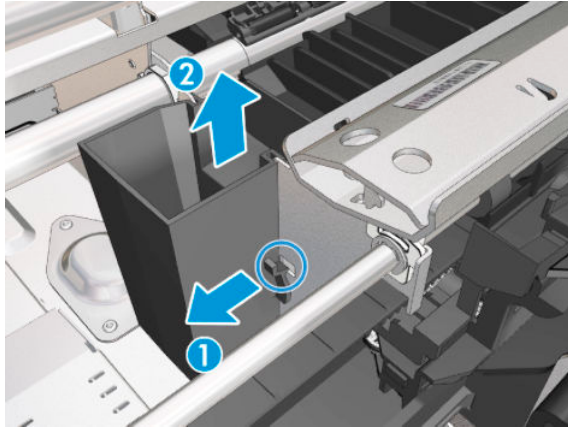

6. Slide up the Left Spittoon until it is detached from the bracket.

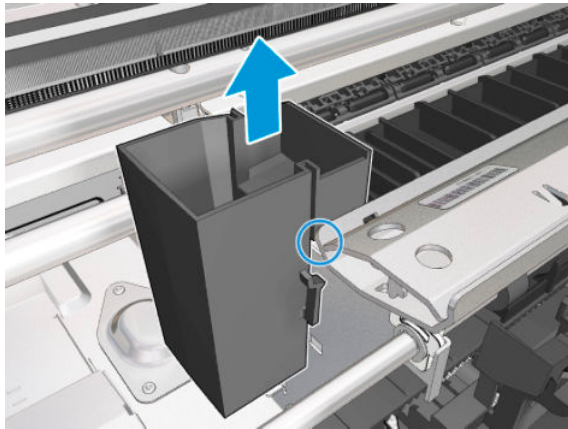

7. Remove the Left Spittoon in the vertical position. You are recommended to wear gloves.

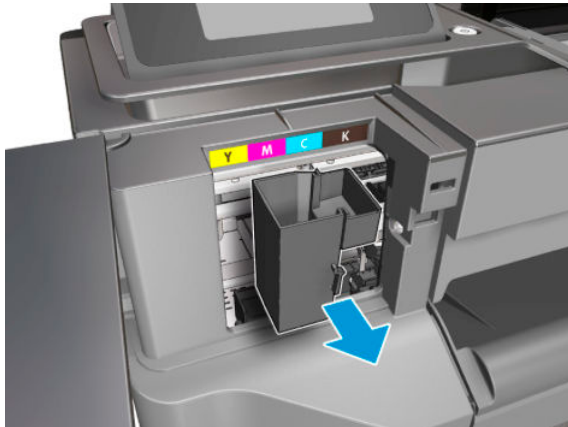

8. Never incline the Left Spittoon, because the ink can fall out.



### Installation

1. When sliding the Left Spittoon down, make sure to slide it by the path of the bracket.

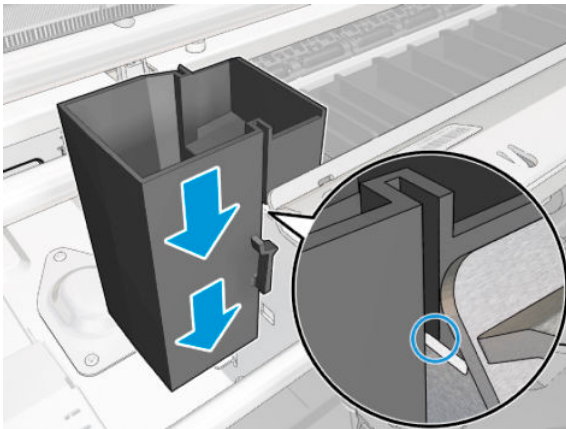

2. Press down the Left Spittoon until you hear a click; make sure the flange is clipped.

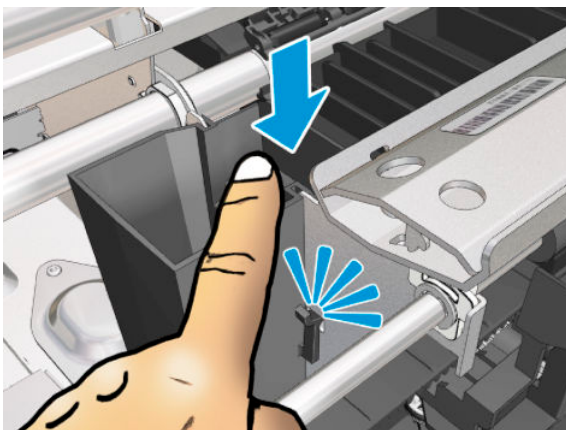

# Scanner Top Cover F9A30-67015

## Removal

**Tools:** Screwdriver Torx 8

1. Remove the five screws.

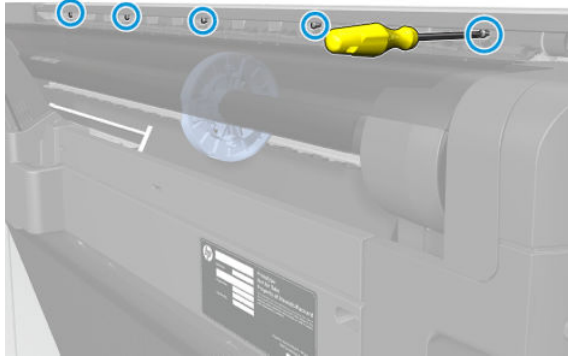

2. Open the Scanner.

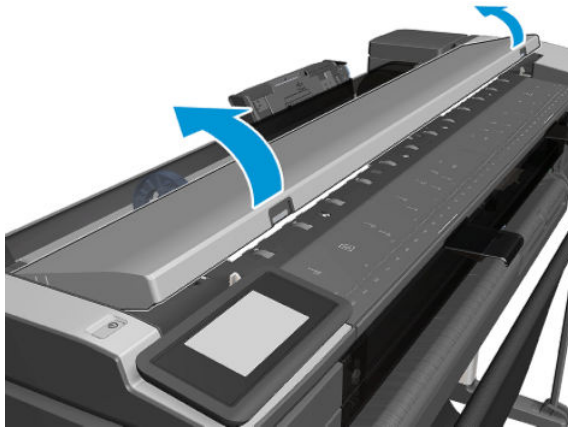

3. Unclip both sides.

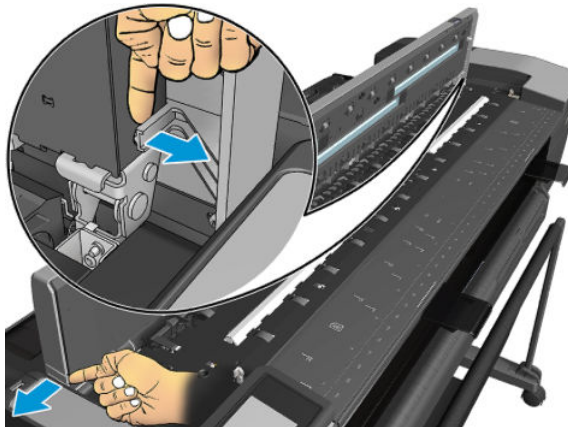

4. Remove the Scanner Top Cover.

**⚠ CAUTION:** Don't close the lid until a new Scanner Top Cover is installed.

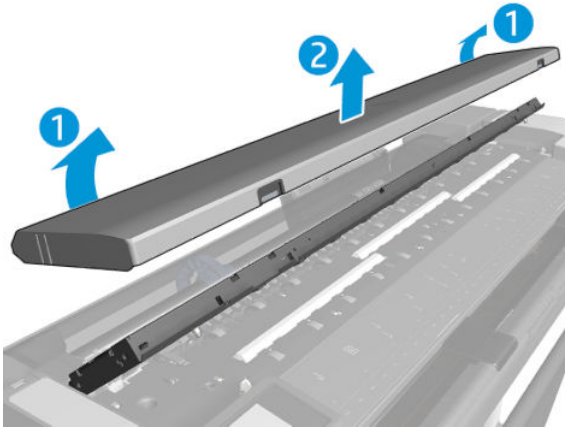

**Installation**

▲ Use a screwdriver to help if there is difficulty opening the Scanner.

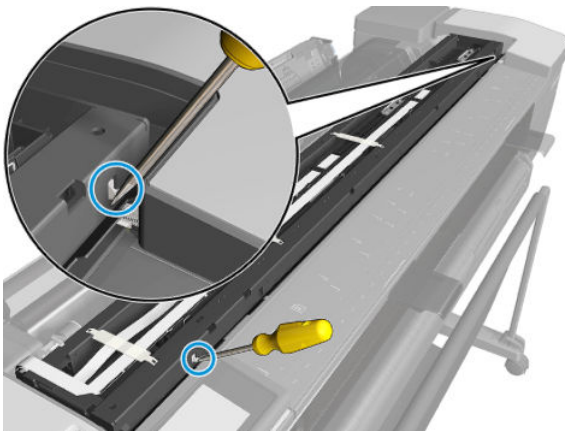

# Scanbars F9A30-67017 (HP DesignJet T830 MFP only)

## Removal

1. Switch off the printer.
2. Unplug the power cable.
3. Open the Scanner.

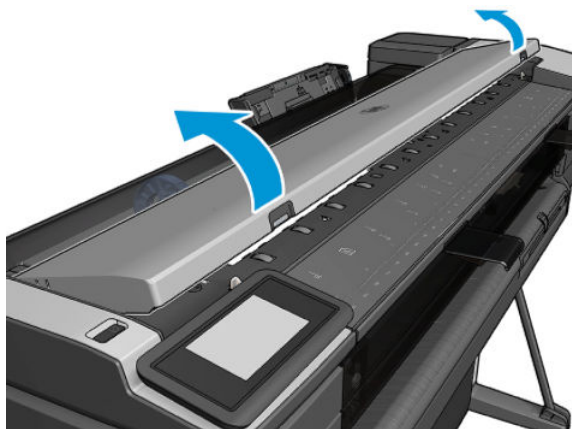

4. Note the location of the three Scanbars.

 **IMPORTANT:** If the scanbars are removed for any other reason than scanbar replacement, take note of the scanbar serial number and the position in the scanner (Service Station side, Middle, Front Panel side etc.). This is important so that the Pristine PRNU (White balance) calibration is not mixed if the scanbar order is changed.

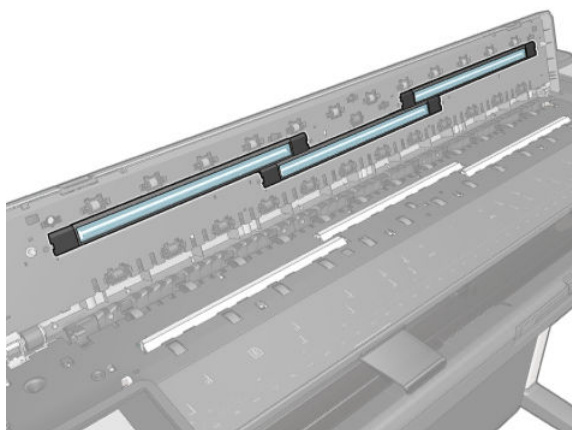

5. Remove the plastic part using a flat screwdriver.

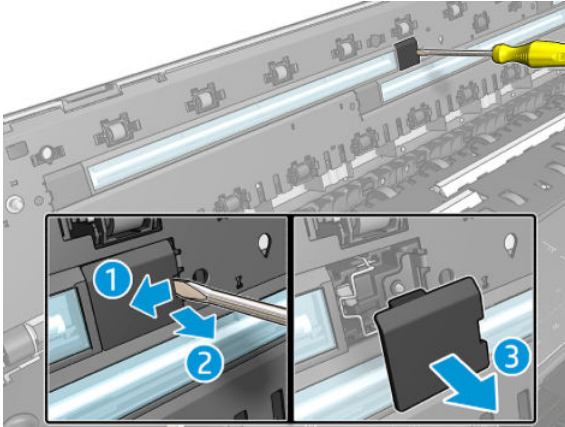

6. Remove the plastic part using a flat screwdriver.

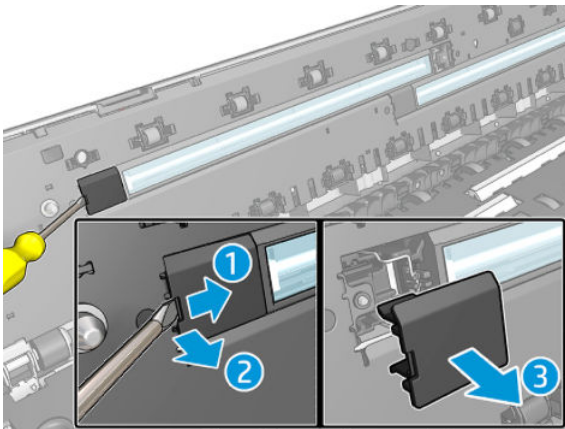

7. Release the spring.

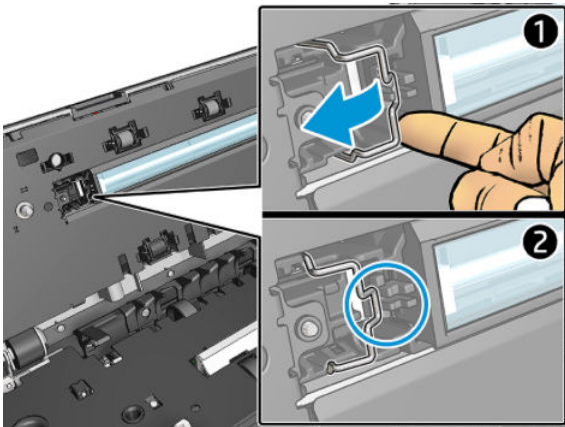

8. Release the spring.

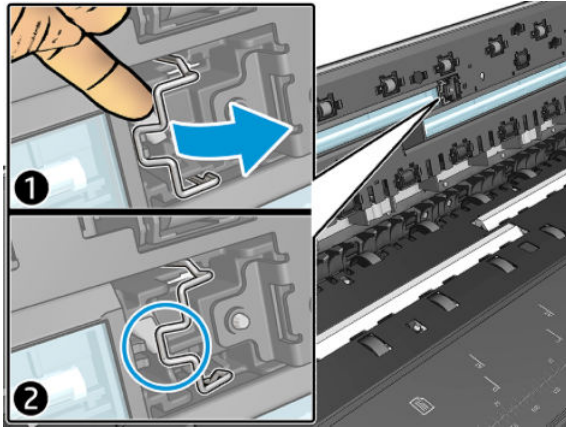

9. Remove the Scanbar.

**⚠ CAUTION:** Take care not to damage the cable.

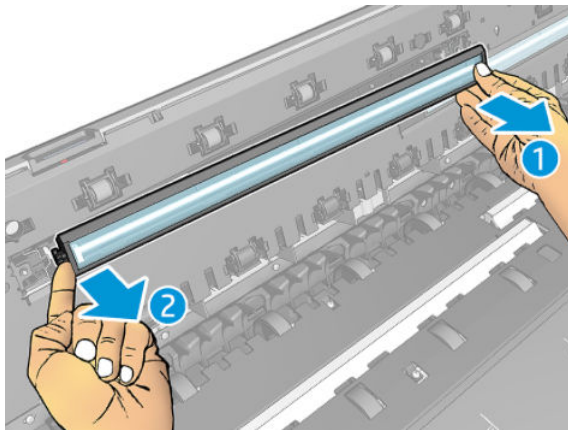

10. Access the cable by carefully rotating the Scanbar.

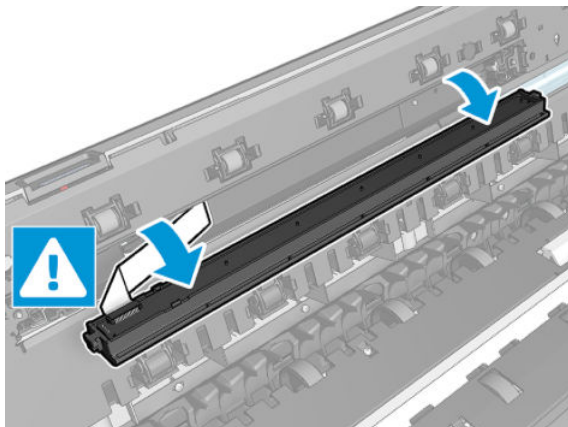

11. Unplug the cable.

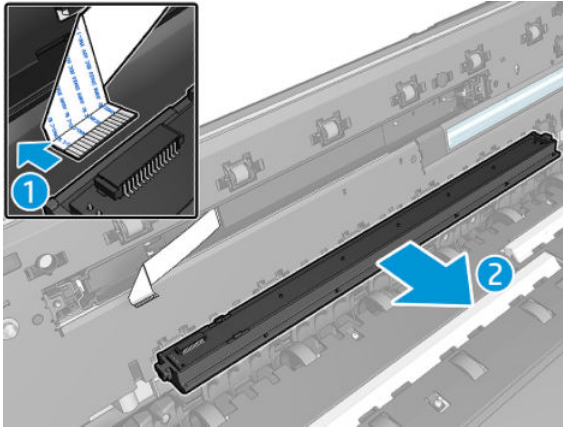

## Installation

1. Remove the new Scanbar from the box.
2. Install the Scanbar by reversing the removal process.

 **NOTE:** Remove the plastic protector from the scanbar after replacing it and before closing the Scanner.

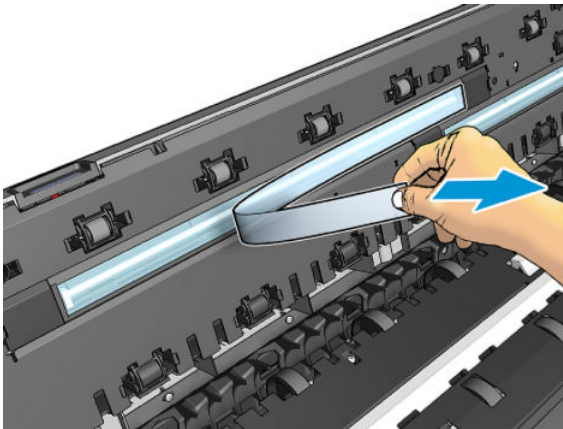

3. Scanbar replacement checklist:
  - a. Replace all 3 scanbars.
  - b. Replace all 3 calibration surfaces.
  - c. Remove films.
  - d. Boot the unit.
  - e. Promote PRNU to Pristine (from Extended Support Menu).
  - f. Run Scanbar alignment calibration.
  - g. Restore Scanner Calibrations (from Extended Support Menu).

 **NOTE:** Scanbar Service kit includes 3 scanbars and 3 calibration surfaces.



 **IMPORTANT:** Be careful when during troubleshooting, if the scanbars are removed take note of the scanbar serial number and the position in the scanner (Service Station side, Middle, Front Panel side etc.). This is important so that the Pristine PRNU (White balance) calibration is not mixed if the scanbar order is changed.

---

# Top Cover Button Latch F9A30-67016 (HP DesignJet T830 MFP only)

## Removal

**Tools:** Screwdriver Torx 8

1. Remove the Scanner Top Cover, see [Scanner Top Cover F9A30-67015 on page 423](#).
2. Unclip the Top Cover Button Latch.

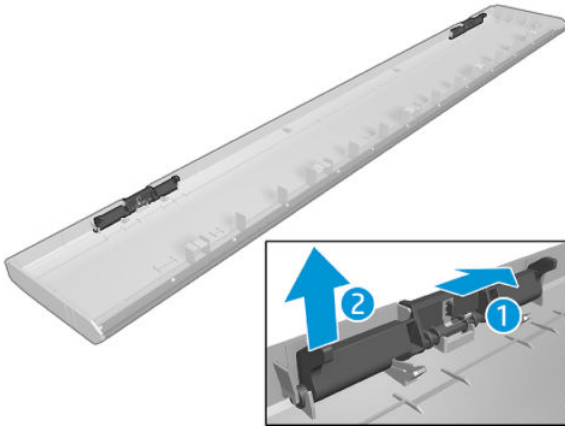

3. Remove the Top Cover Button Latch.

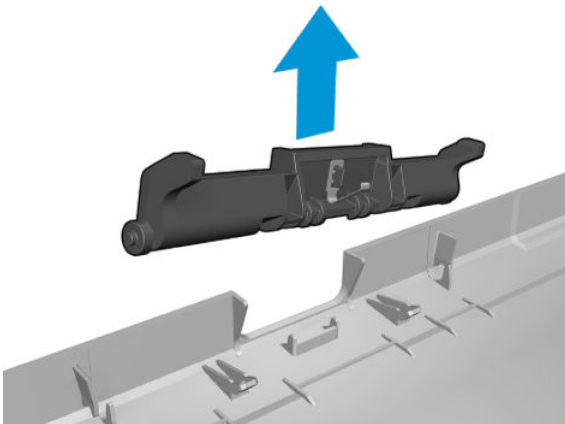

## Installation

1. Before installation, check the latches are working properly.
2. Reverse the removal process.

# Bottom Platen F9A30-67042

## Removal

1. Open the scanner.

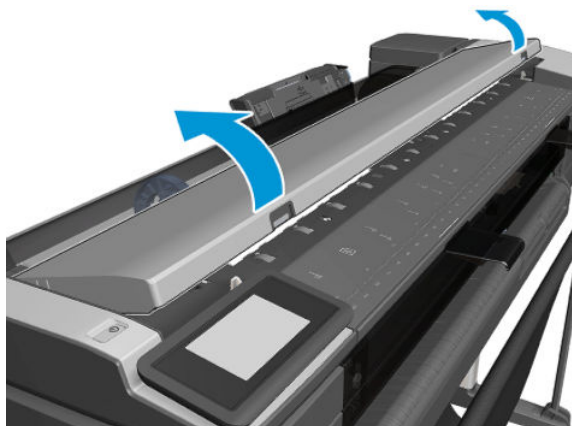

2. Remove the twelve T10 screws.

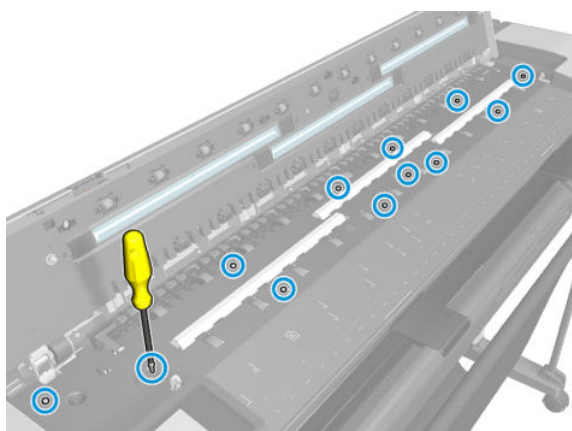

3. Remove the Bottom Platen.

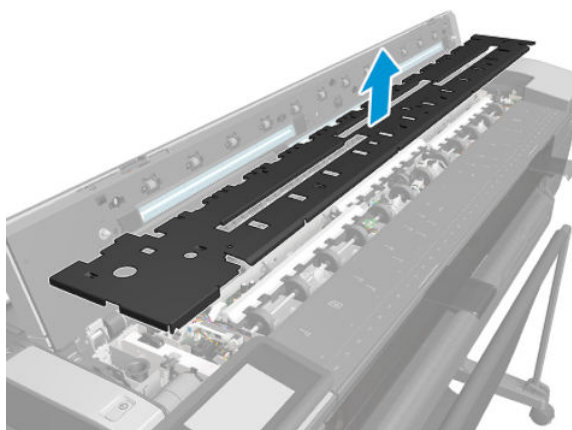

## Installation

- ▲ Install the Bottom Platen by reversing the removal process.

# Scan Bundle Board F9A30-67029

## Removal

**Tools:** Screwdriver Torx 10

1. Remove the Bottom Platen, see [Bottom Platen F9A30-67042 on page 431](#).
2. Disconnect all the cables.

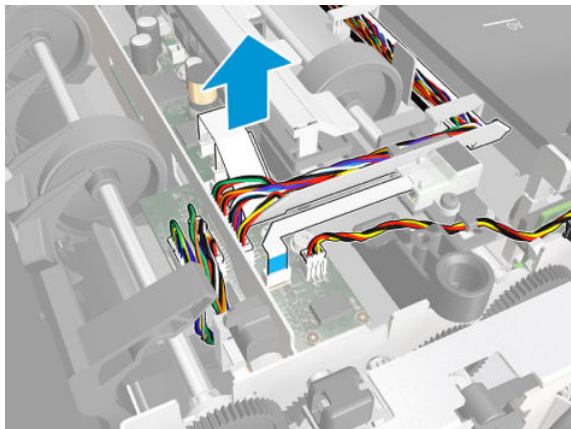

3. Remove the three screws.

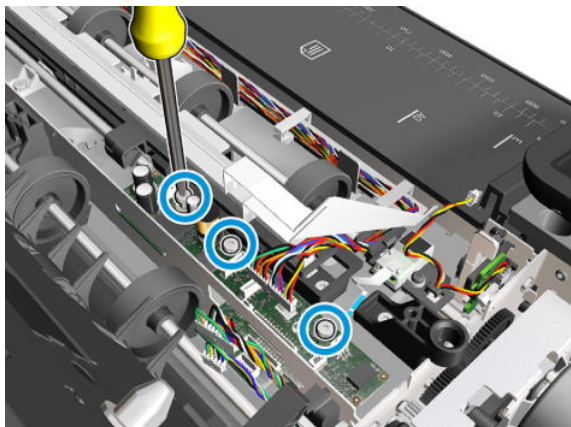

4. Remove the Scan Bundle Board.

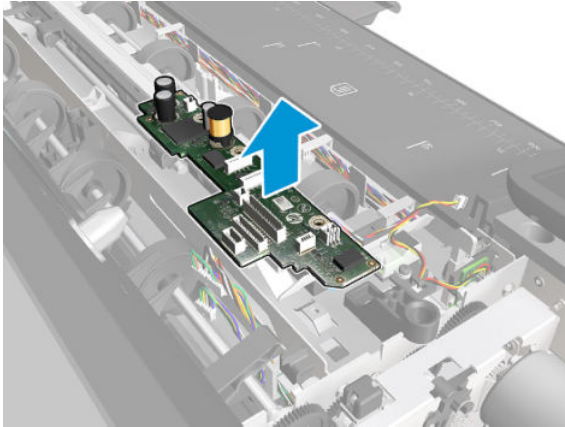

### Installation

- ▲ Install the Scan Bundle Board by reversing the removal process.

 **NOTE:** Once the Scanner Bundle Board is replaced, when the printer boots up a System Error 0009-0174 will appear. This is an expected behaviour. After pressing "OK" to hide the System error, proceed to **Extended Support Menu** for NVM sync.



 **IMPORTANT: MFP only:** Synchronize the Main PCA and Scan Bundle Board after Scan Bundle Board PCA replacement: **Extended Support Menu** ► **"Scanner save calibrations"**.

# Scanner Feed Motor F9A30-67024

## Removal

**Tools:** Screwdriver Torx 10

1. Remove the Bottom Platen, see [Bottom Platen F9A30-67042 on page 431](#).
2. Disconnect the cable.

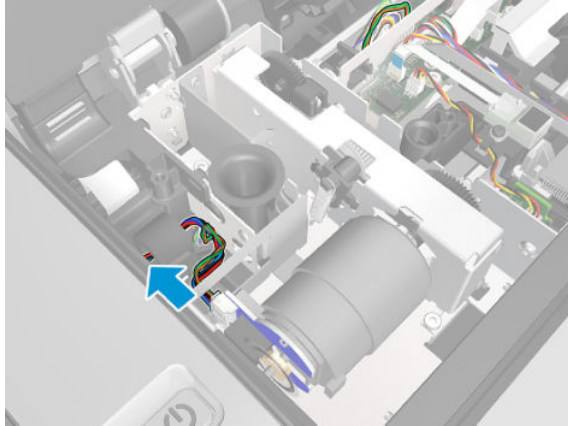

3. Remove the two screws.

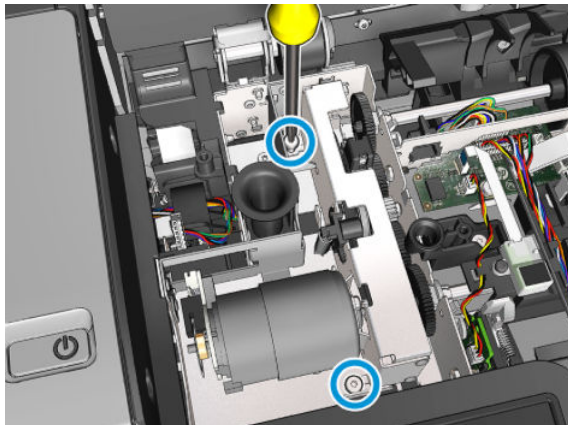

4. Remove the Scanner Feed Motor.

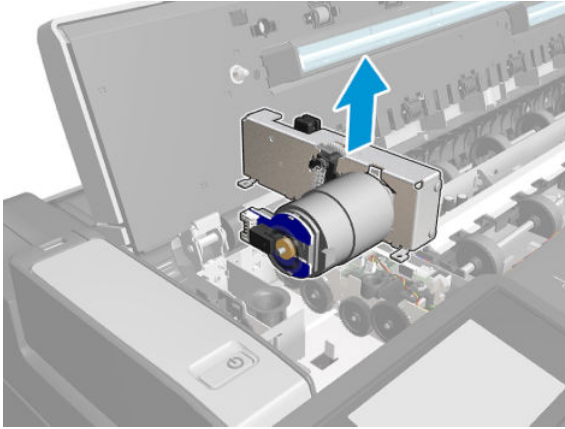

**Installation**

▲ Install the Scanner Feed Motors by reversing the removal process.

 **NOTE:** Make sure that the motor gear train pin is inserted into the scanner wall.

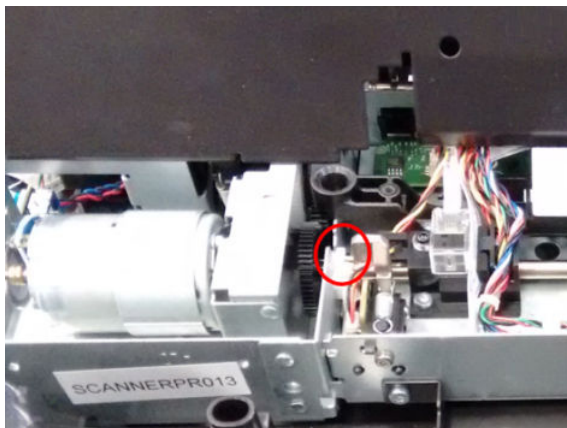



# Hinges F9A30-67019 (HP DesignJet T830 MFP only)

## Removal

**Tools:** Screwdrivers; Torx 8, 10, 15, and 25

1. Remove the Scanner Module, see [Scanner Module on page 505](#).
2. Remove the Top Cover Scanner, see [Scanner Top Cover F9A30-67015 on page 423](#).
3. Remove 1 screw.

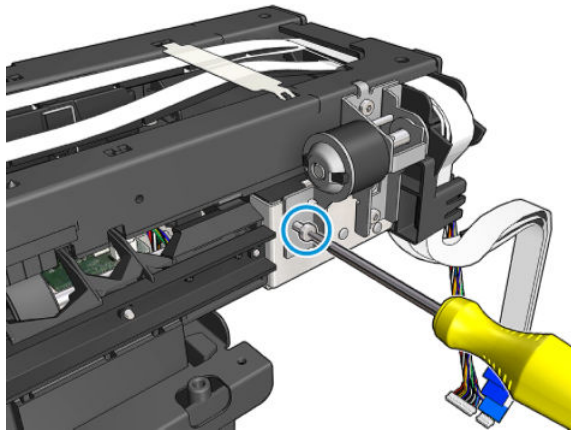

4. Remove the bracket Hinge Damper.

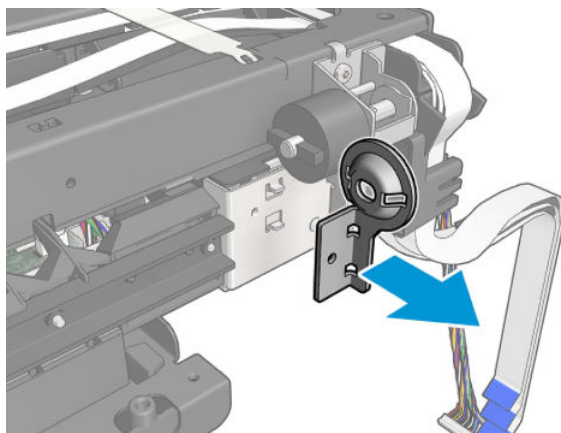

5. Remove the Hinge Damper.

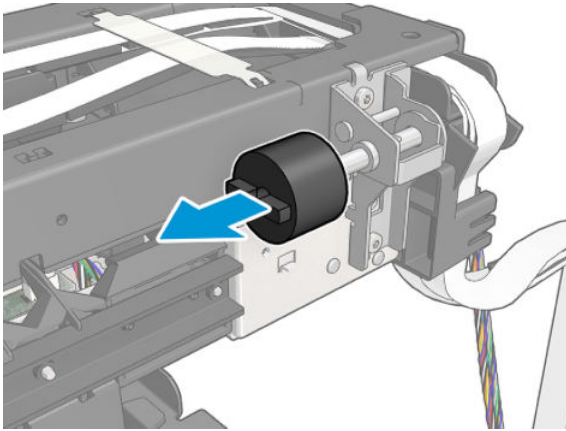

6. Remove 4 screws.

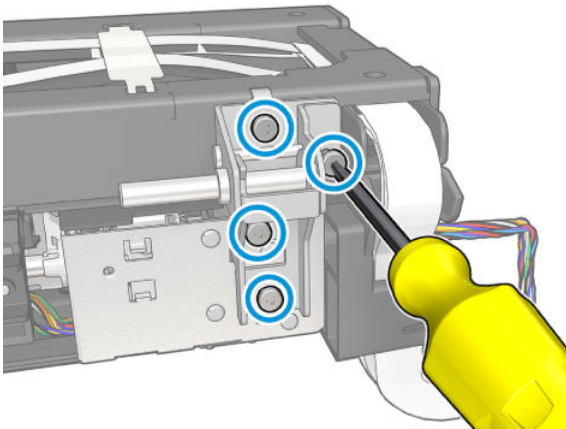

7. Remove the bracket Hinge.

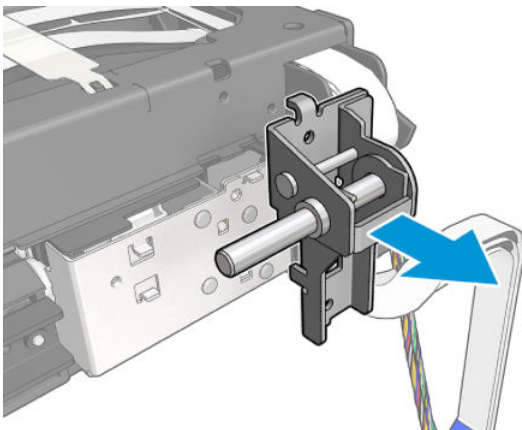

8. Remove 4 screws.

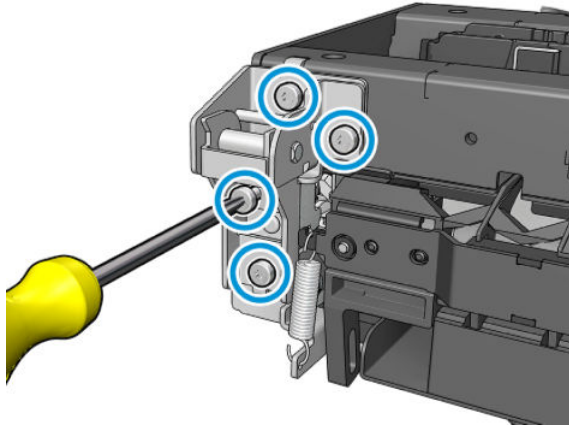

9. Remove the bracket Hinge.

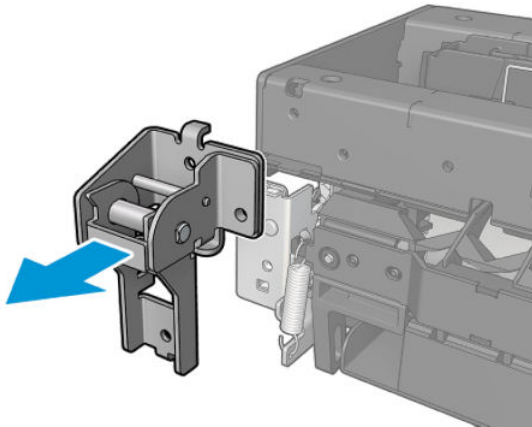

### Installation

1. Install the Hinges by reversing the removal process.
2. Run scanbar alignment and PRNU target compensation.

# Scanner Feedshaft (Front) F9A30-67025

## Removal

**Tools:** Screwdriver Torx 10

1. Remove the Bottom Platen, see [Bottom Platen F9A30-67042 on page 431](#).
2. Unroute the cable.

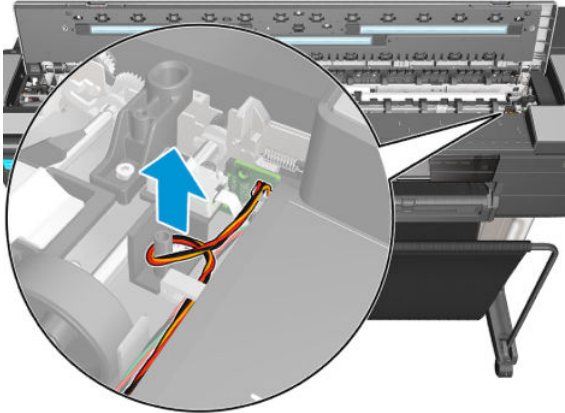

3. Remove one screw from the Right Optical sensor.

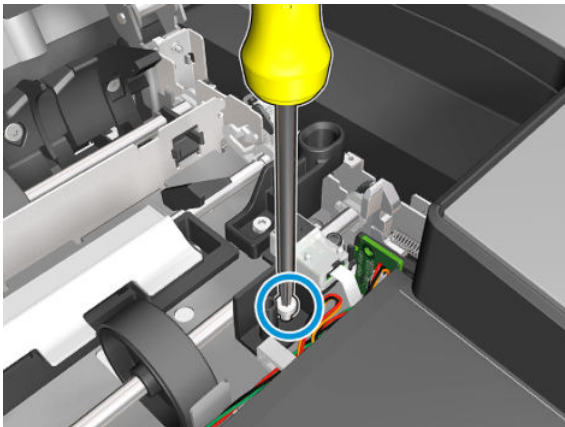

4. Disconnect the FFC cable from the Optical sensor and remove the sensor.

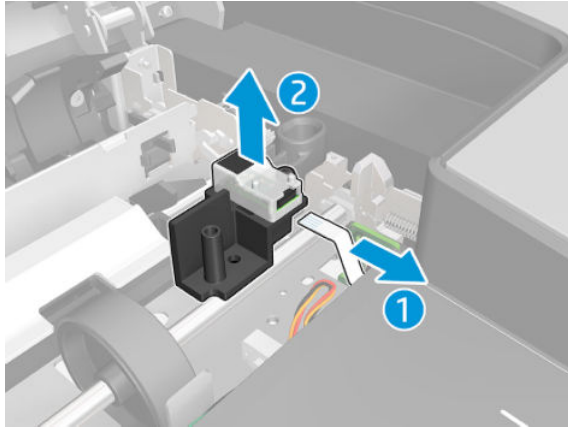

5. Disconnect the FFC cable from the TOF Optical sensor.

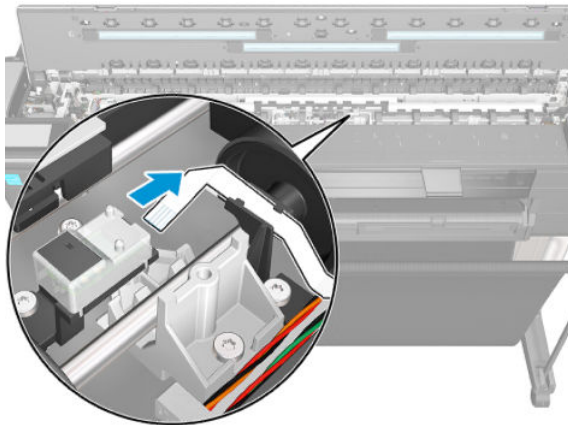

6. Remove one screw from the TOF Optical sensor support. Leave it on the input platen.

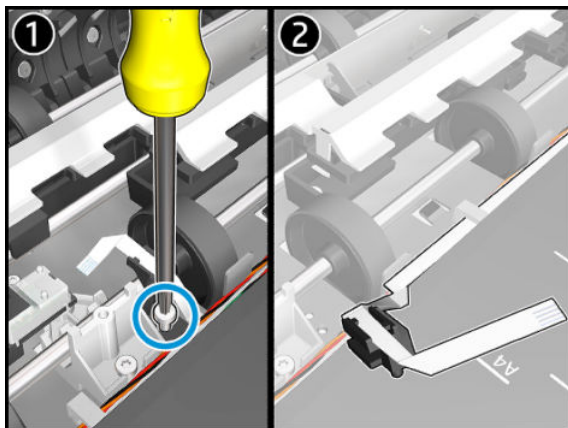

7. Remove two screws from the OPT Wheel.

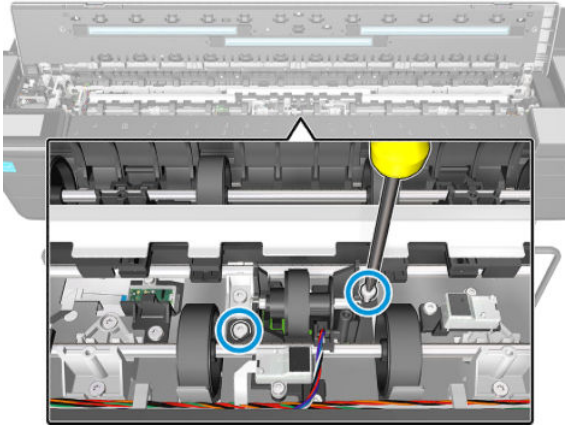

8. Leave the OPT Wheel with the cable on the input platen.

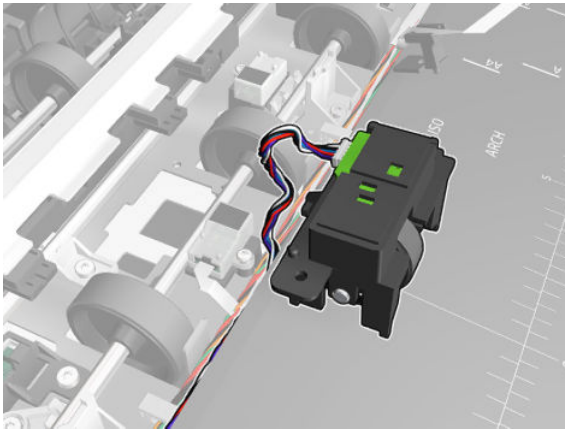

9. Remove two screws from the BOF Optical sensor.

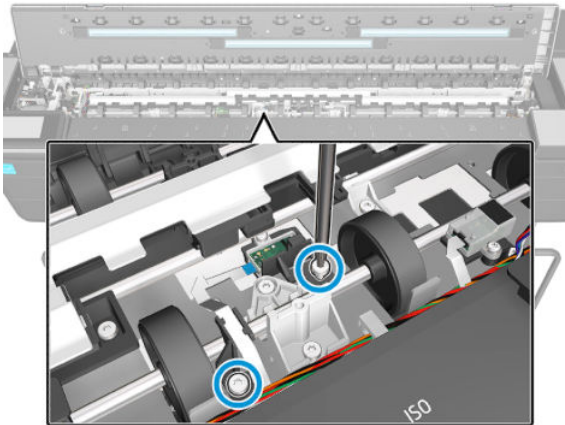

10. Leave the BOF Optical sensor with the cable and holder on the input platen.

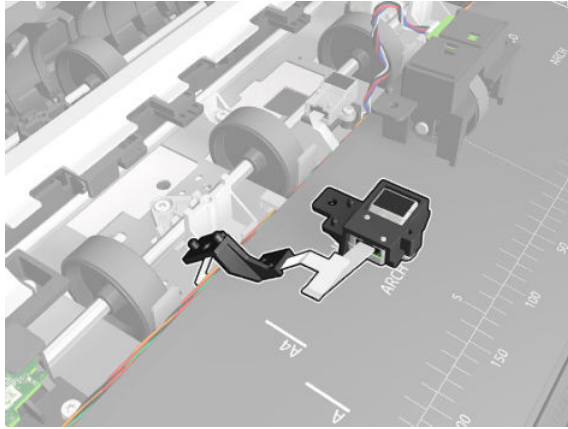

11. Remove one screw from the Sensor LID and leave it on the input platen.

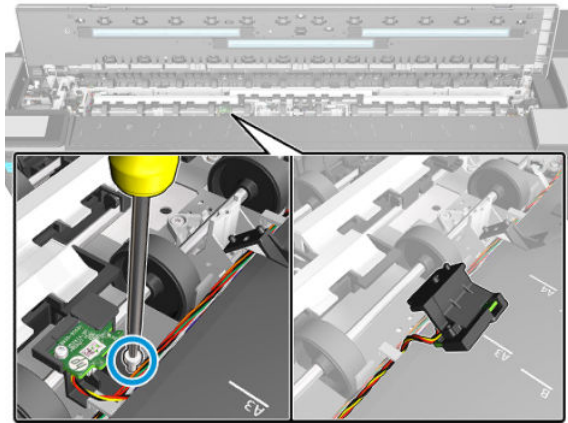

12. Remove one screw from the Middle Lid Magnetic Sensor.



13. Disconnect all the cables from the Scan Bundle Board and leave them on the input platen.

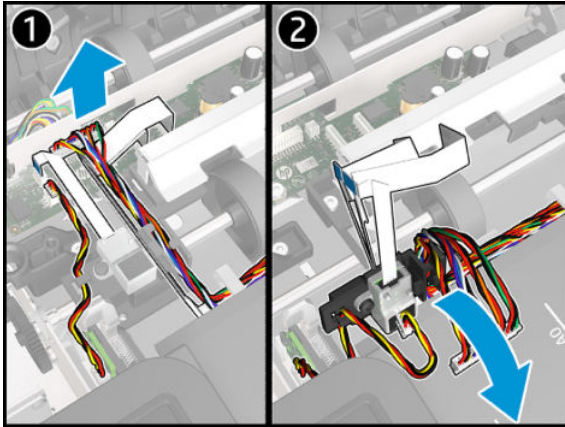

14. Unclip and rotate the right Bearing.

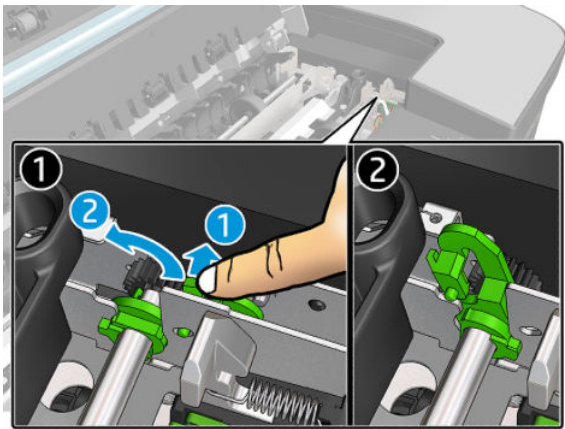

15. Unclip and rotate the Left Bearing.

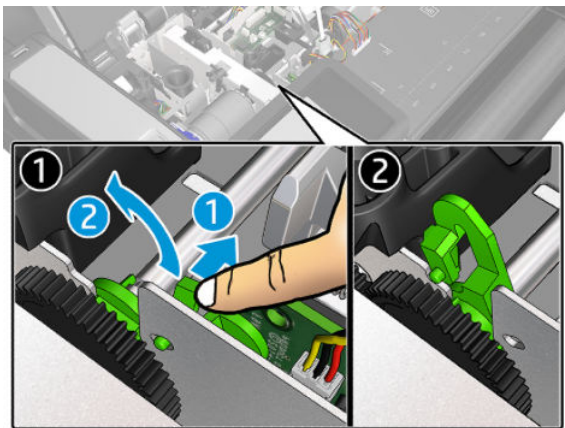



**16.** Remove the Scanner Feedshaft (Front).

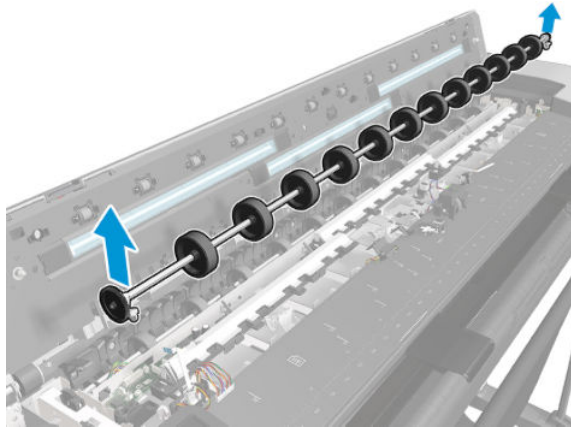

**Installation**

- ▲ Install the Scanner Feedshaft (Front) by reversing the removal process.

 **NOTE:** Make sure feedshaft bearing snaps into lock groove.

# Scanner Feedshaft (Rear)

## Removal

1. Remove the Bottom Platen, see [Bottom Platen F9A30-67042 on page 431](#).
2. Unclip and rotate the right Bearing.

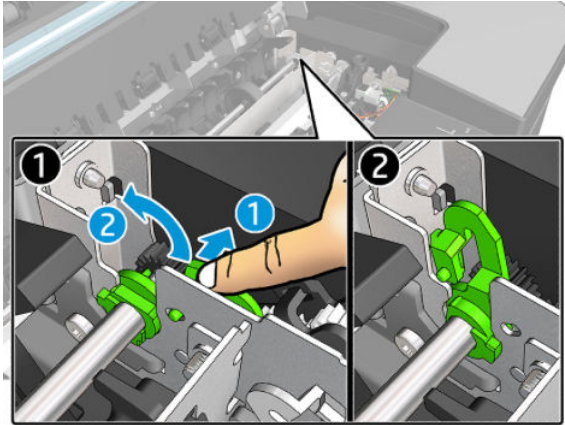

3. Unclip and rotate the left Bearing.

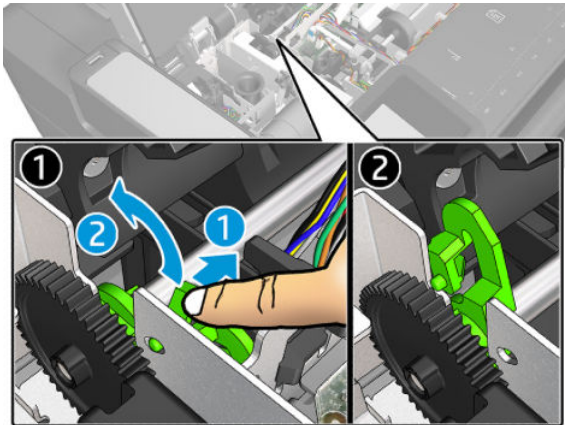

4. Remove the Scanner Feedshaft (Rear).

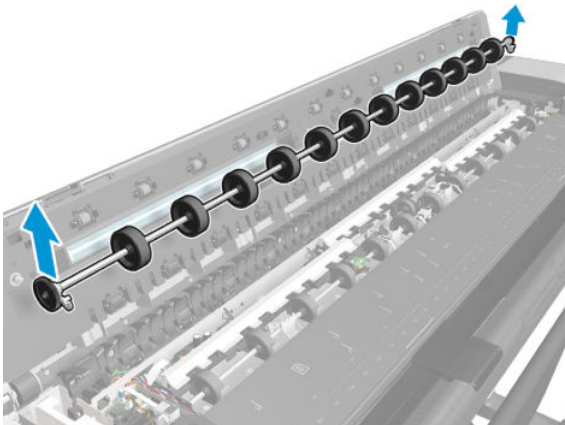

## Installation

- ▲ Install the Scanner Feedshaft (Rear) by reversing the removal process.

---

 **NOTE:** Make sure feedshaft bearing snaps into lock groove.

---

# Bottom Cables F9A30-67034

## Removal

1. Remove the Bottom Platen, see [Bottom Platen F9A30-67042 on page 431](#).
2. Disconnect the cable and detach it.

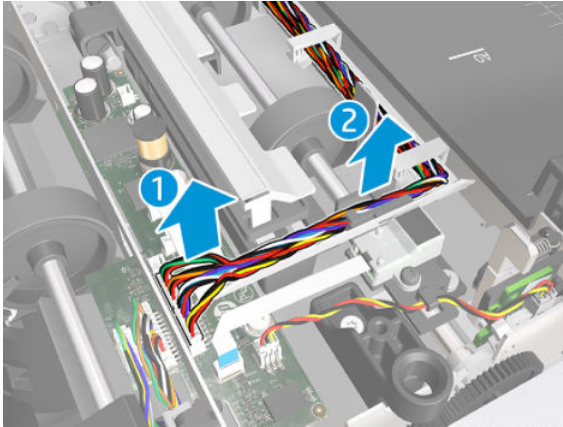

3. Open the ten wire-saddles.

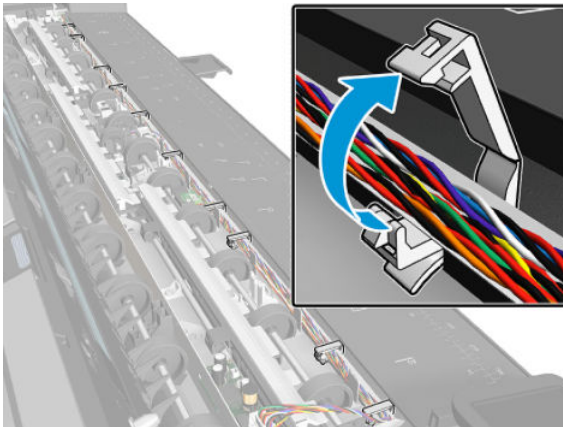

4. Remove one screw from the Middle Lid Magnetic Sensor .

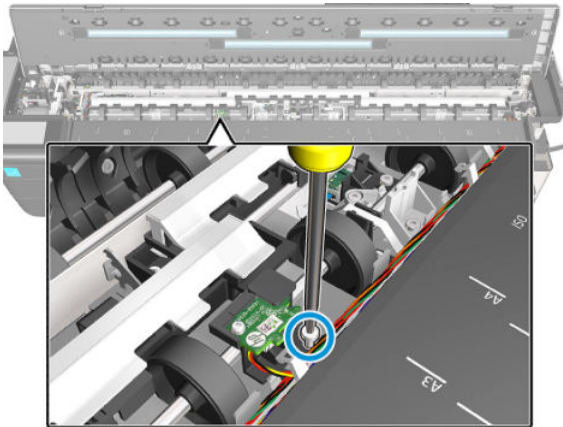

5. Disconnect the cable from the Lid Magnetic Sensor and remove it.

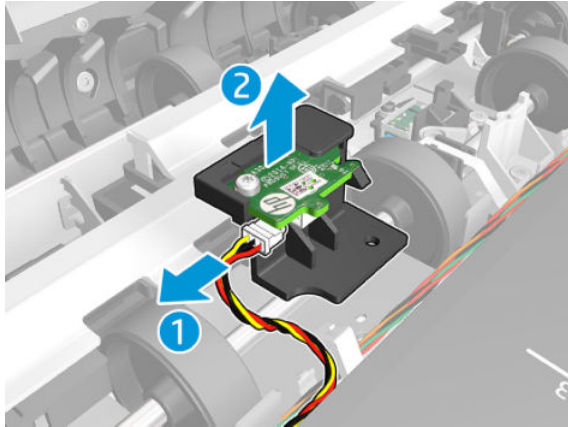

6. Remove two screws from the OPT Wheel.

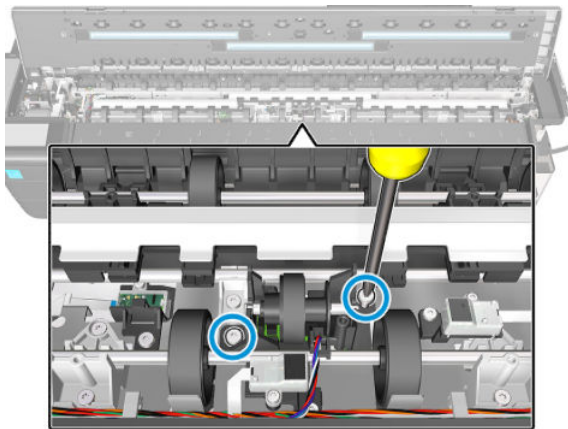

7. Disconnect and detach the cable from the OPT Wheel.

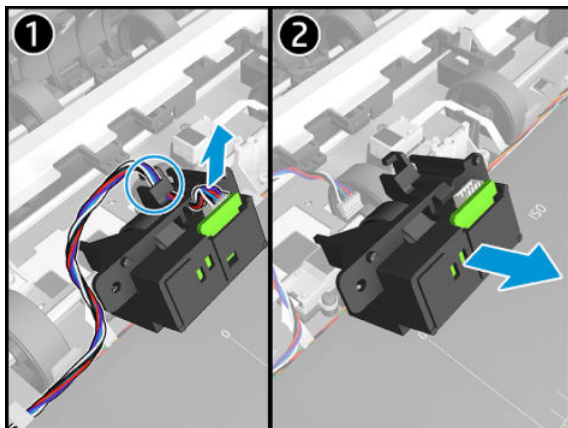

8. Disconnect the cable from the Latch Magnetic Sensor.

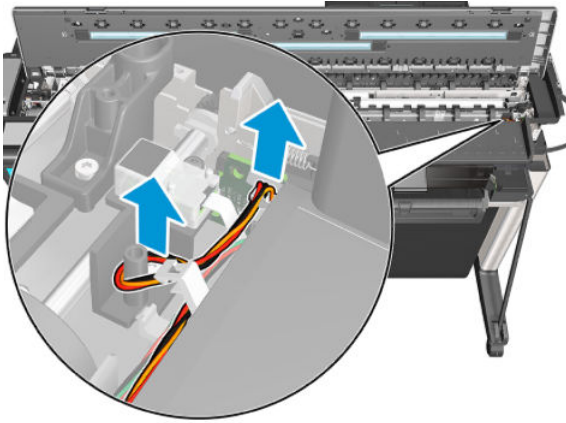

9. Disconnect the cable from the Diverter Magnetic Sensor and unroute it through the hole.

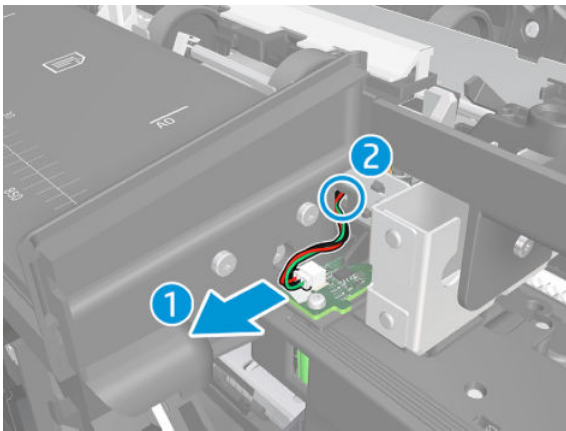

10. Remove the cables.

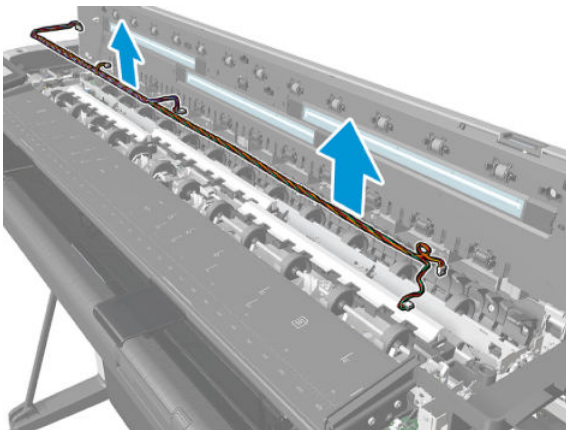

11. Disconnect two FFC cables from the Scan Bundle Board PCA.

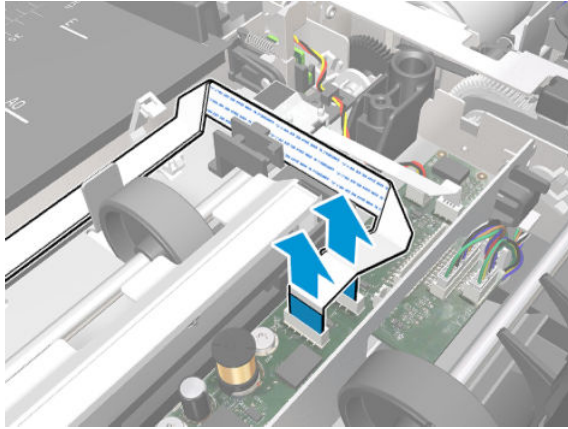

12. Detach the two FFC cables from the wire-saddles and holders.

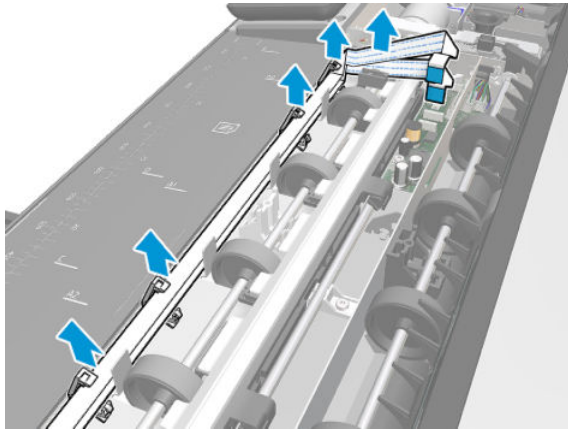

13. Disconnect and detach the two FFC cables from the bottom and top Form Optical Sensor, then disconnect one FFC cable from Load Optical Sensor.



14. Disconnect the FFC cable from the OPT right optical sensor.

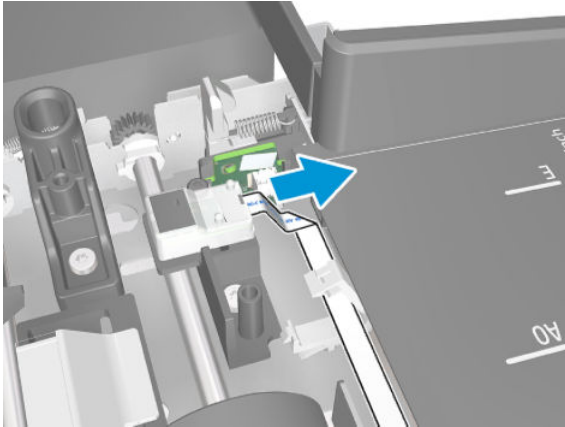

15. Remove the FFC cables.

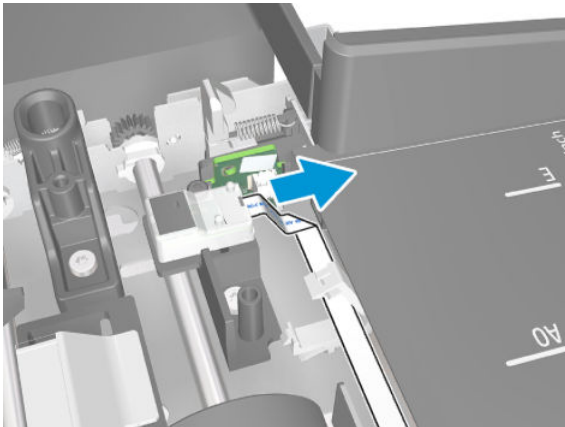

## Installation

- ▲ Install the Bottom Cables by reversing the removal process.



# OPT Wheel F9A30-60038

## Removal

**Tools:** Screwdriver Torx 10

1. Remove the Bottom Platen, see [Bottom Platen F9A30-67042 on page 431](#).
2. Remove two screws from the OPT Wheel.

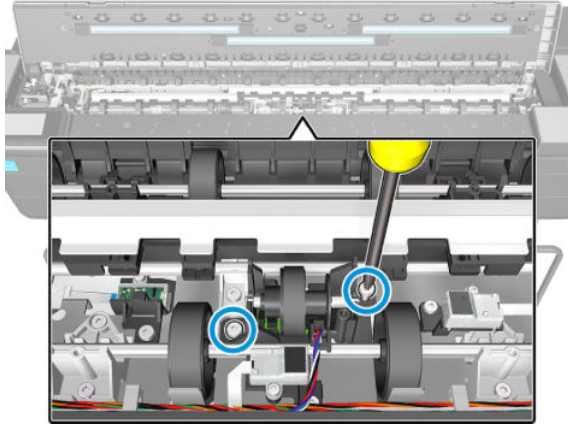

3. Disconnect and detach the cable from the OPT Wheel, then remove it.

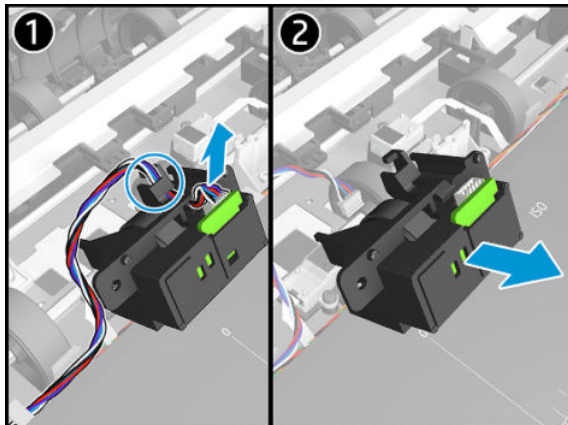

## Installation

1. Install the OPT Wheel by reversing the removal process.
2. Run the following calibrations:
  1. Scanner Runout (media advance) calibration,
  2. Scanbar alignment and
  3. Scanner analog encoder calibrations.

## Sensor SV Kit F9A30-67031

The Sensor SV Kit contains all optical sensors in the scanner. The removal and assembly for each sensor is described in the following pages, although it is likely that only one of them be replaced at a time.

### Lid Magnetic Sensor F9A30-60034

#### Removal

1. Remove the Bottom Platen, see [Bottom Platen F9A30-67042 on page 431](#).
2. Remove one screw from the Lid Magnetic Sensor.

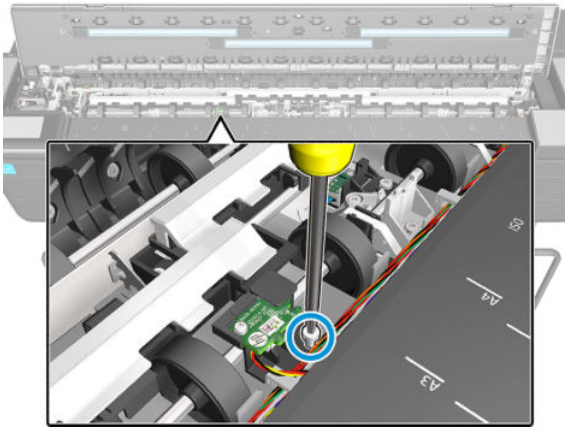

3. Disconnect and detach the cable from the Lid Magnetic Sensor. Remove it.

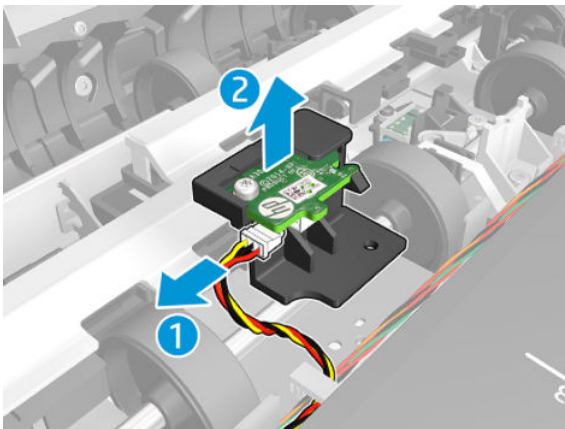

#### Installation

- ▲ Install by reversing the removal process.

## Bottom of Form (BOF) Optical Sensor F9A30-60030

### Removal

1. Remove the Bottom Platen, see [Bottom Platen F9A30-67042 on page 431](#).
2. Remove one screw from the Bottom of Form Optical Sensor.

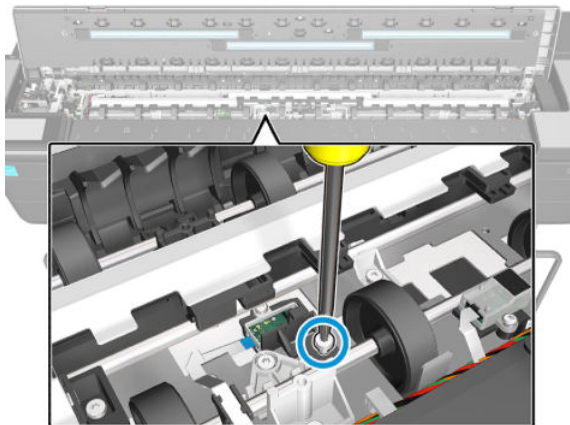

3. Disconnect and remove the Bottom of Form Optical Sensor.

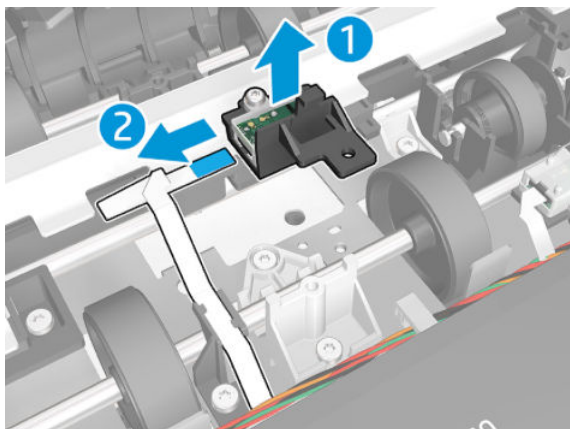

### Installation

- ▲ Install by reversing the removal process.

## Load optical Sensor F9A30-60035

### Removal

1. Remove the Bottom Platen, see [Bottom Platen F9A30-67042 on page 431](#).
2. Disconnect the cable from the Load optical Sensor.

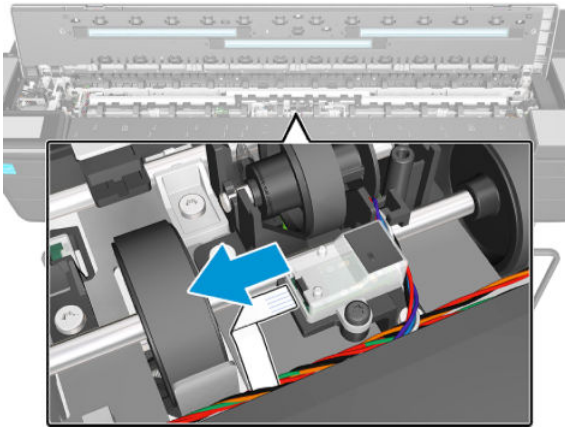

3. Remove one screw.

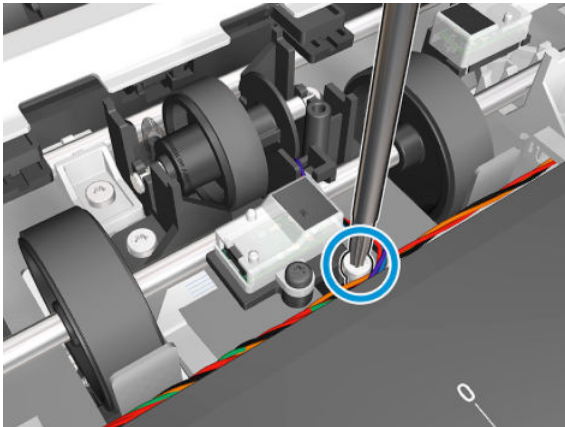

4. Remove the Load optical Sensor.

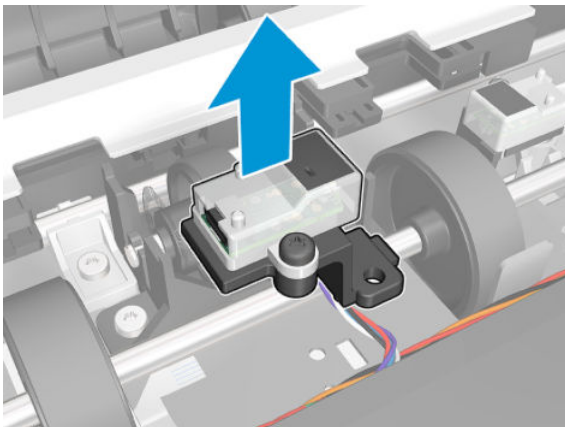

## Installation

- ▲ Install by reversing the removal process.

## Top of Form (TOF) Optical Sensor F9A30-60035

### Removal

1. Remove the Bottom Platen, see [Bottom Platen F9A30-67042 on page 431](#).
2. Disconnect the cable from the Top of Form Optical Sensor.

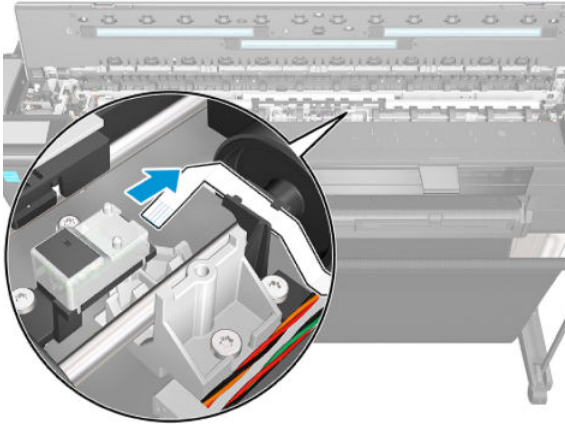

3. Remove one screw.

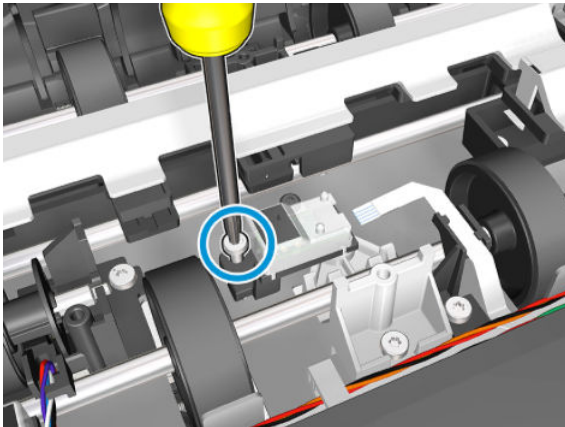

4. Remove the Top of Form Optical Sensor.

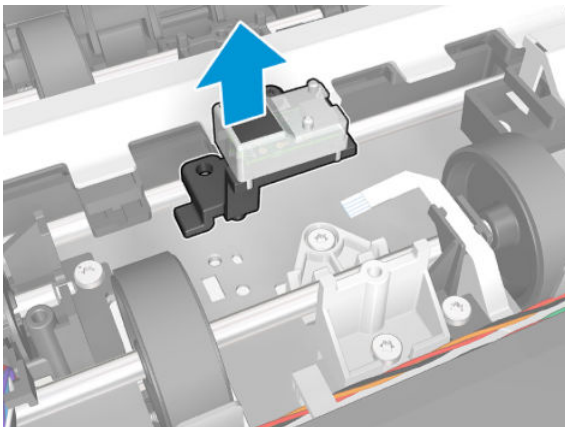

## Installation

- ▲ Install by reversing the removal process.

## Right Optical Sensor F9A30-60187

### Removal

1. Remove the Bottom Platen, see [Bottom Platen F9A30-67042 on page 431](#).
2. Detach the cable from the Mount OPT Right Optical Sensor.

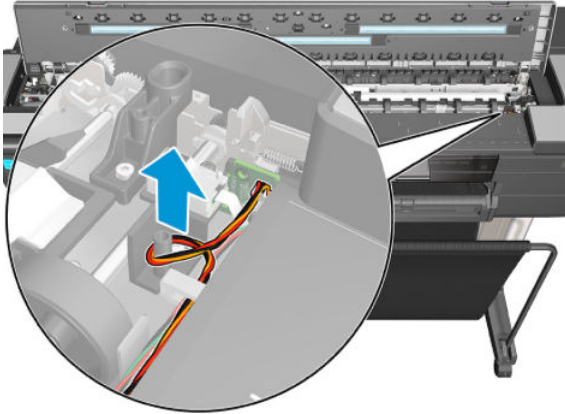

3. Remove one screw.

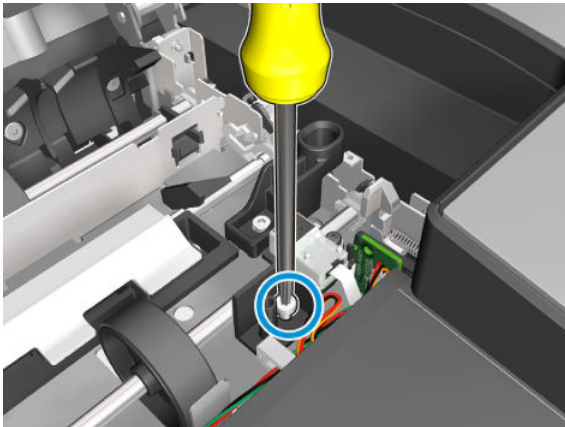

4. Disconnect the cable and remove the OPT Right Optical Sensor.

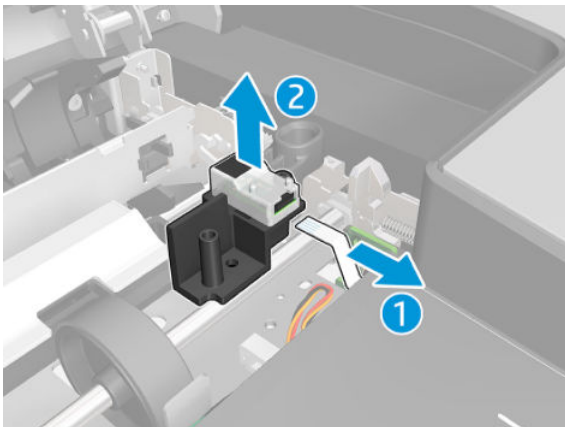



## Installation

- ▲ Install by reversing the removal process.

## Left Optical Sensor F9A30-60188

### Removal

1. Remove the Bottom Platen, see [Bottom Platen F9A30-67042 on page 431](#).
2. Remove one screw.

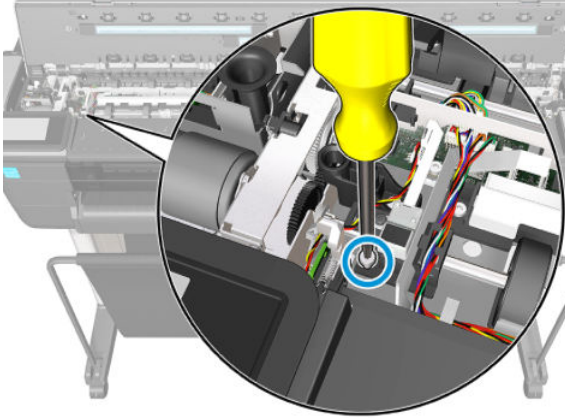

3. Disconnect the cable and detach all cables from the Mount OPT Left Optical Sensor.

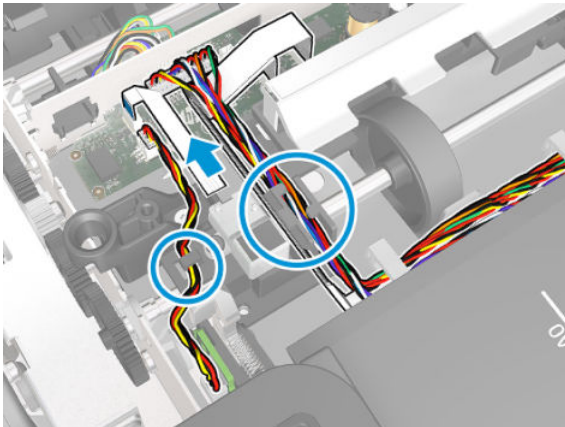

4. Remove the OPT Left Optical Sensor.

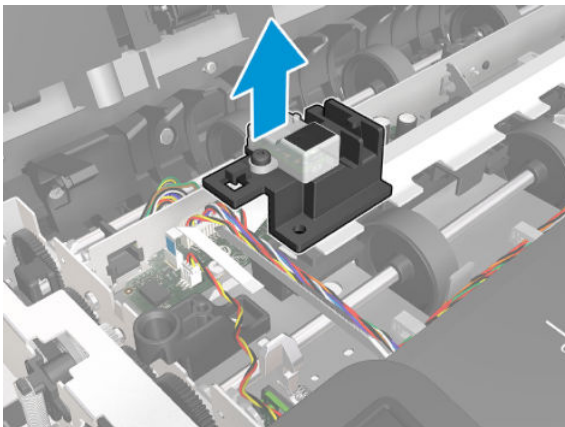

## Installation

- ▲ Install by reversing the removal process.

## Rear Cover (MFP only)

### Removal

1. Open the Roll Cover.



2. Remove the three screws.

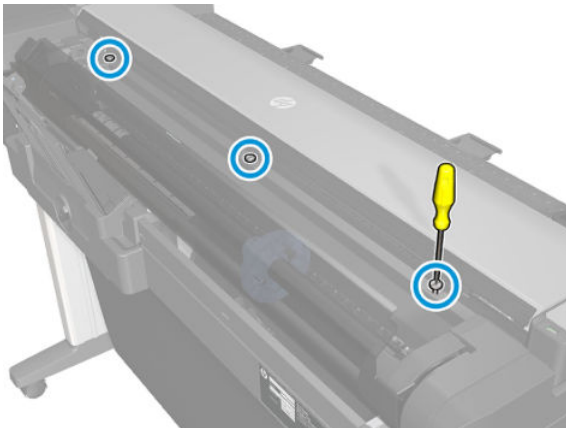

3. Remove the Rear Cover.

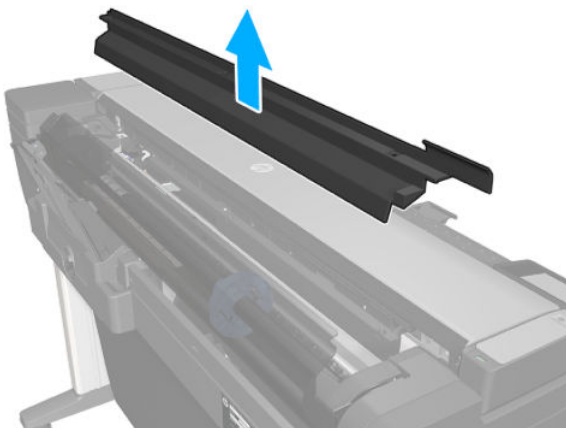

## Installation

- ▲ Install the Rear Cover by reversing the removal process.

# Scanbar FFC F9A30-67018

## Removal

**Tools:** Screwdrivers; Torx 10, 15, 20, and 25

1. Remove the Rear Cover, see [Rear Cover \(MFP only\) on page 464](#).
2. Remove the Left Cover, see [Left Cover MFP SV Kit F9A30-67012 on page 268](#).
3. Remove the Bottom Platen, see [Bottom Platen F9A30-67042 on page 431](#).
4. Remove the Scanbar, see [Scanbars F9A30-67017 \(HP DesignJet T830 MFP only\) on page 425](#).
5. Pass the three FFC Cables through the holes.

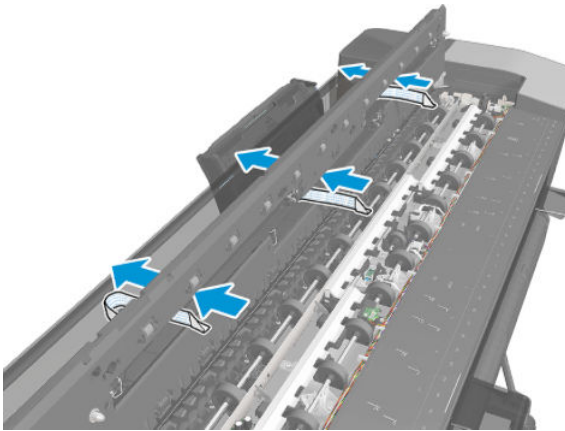

6. Detach the three FFC Straps.

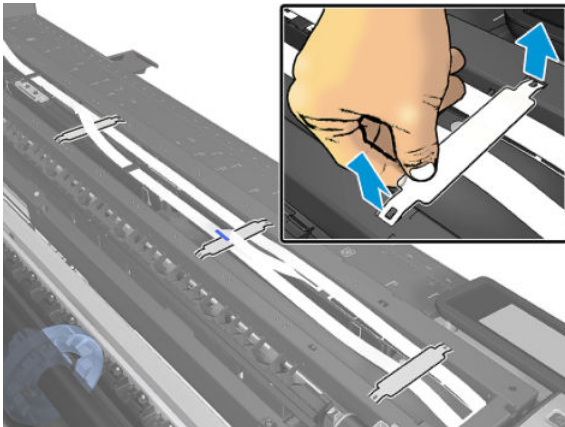

7. Remove the FFC Straps from the FFC cables (stick/glue).

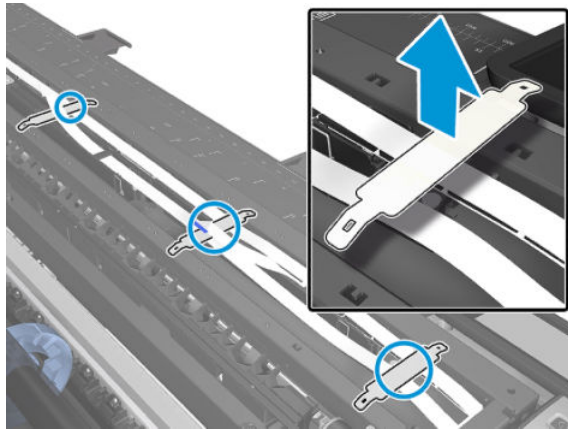

8. Note the location of the three ferrites.

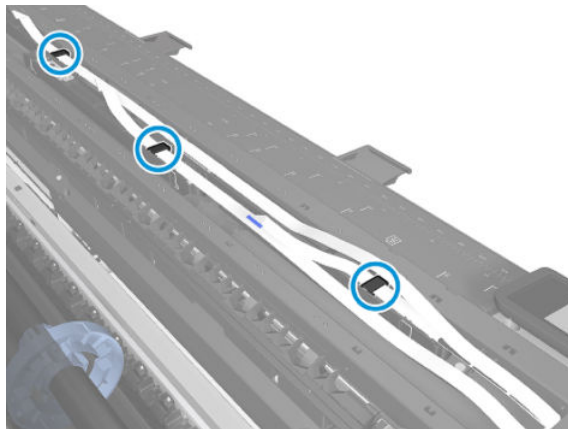

9. Unclip the three ferrites and remove them from the FFC Cables.

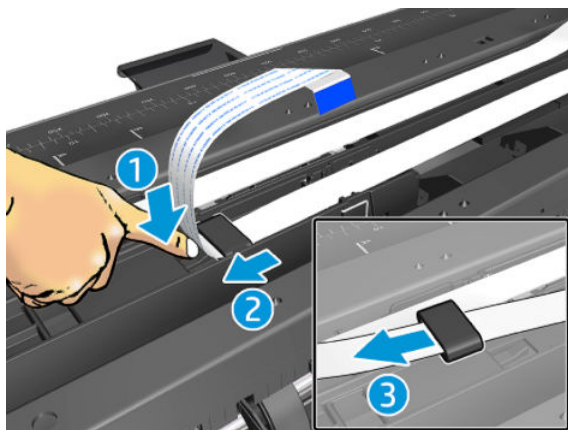

10. Slide out the bracket cable but don't remove it yet.

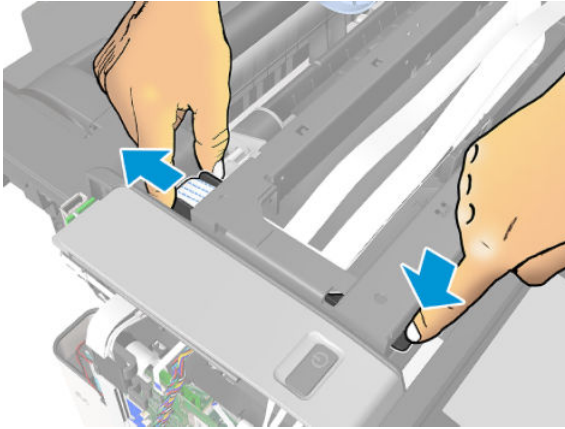

11. Disconnect the three FFC cables.

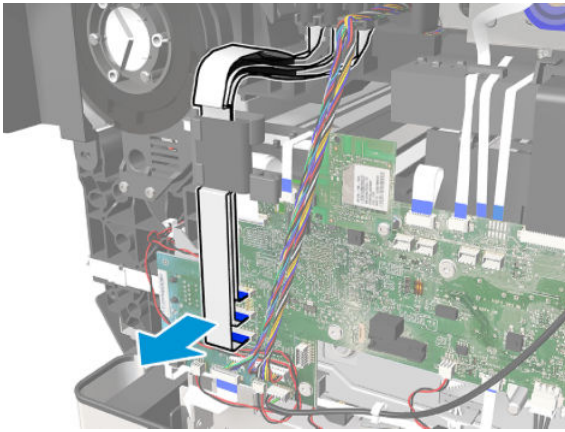

12. Remove one screw.

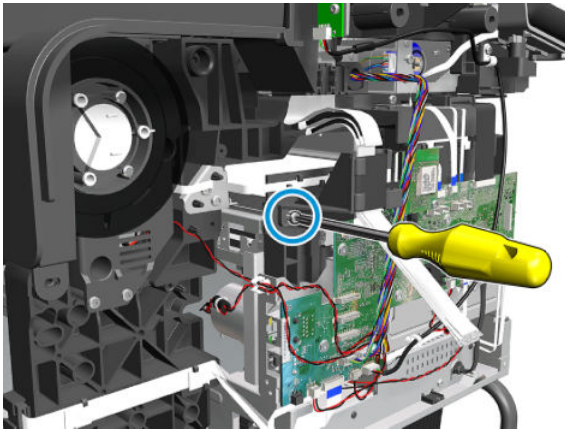



13. Remove the Ferrite and holder from the FFC Cables.

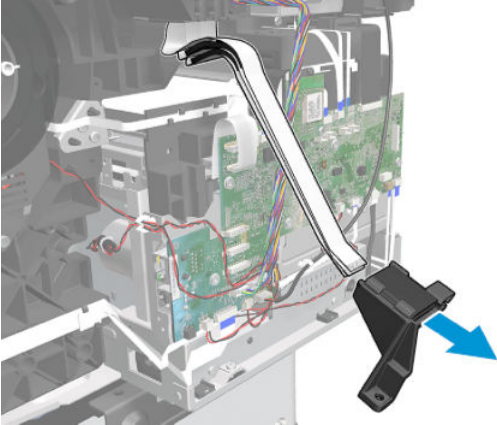

14. Remove one screw.

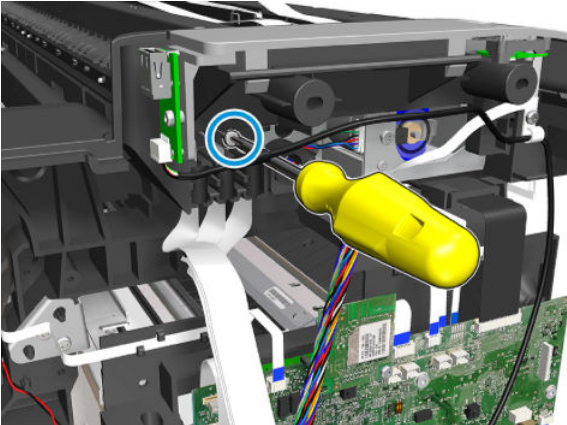

15. Detach the Ferrite from the bracket.

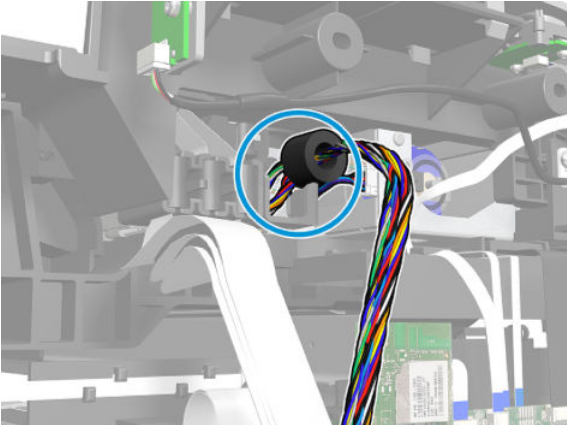

16. Open the scanner.

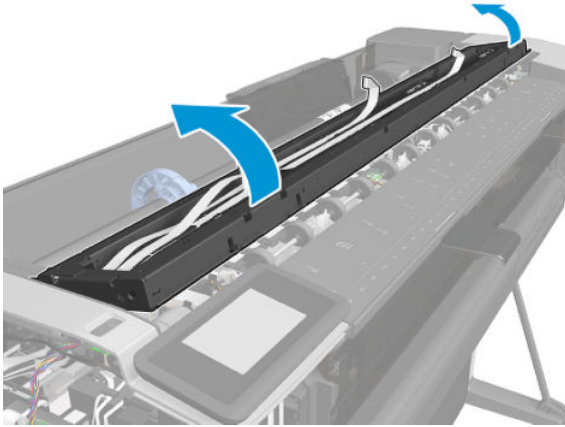

17. Detach the bracket.

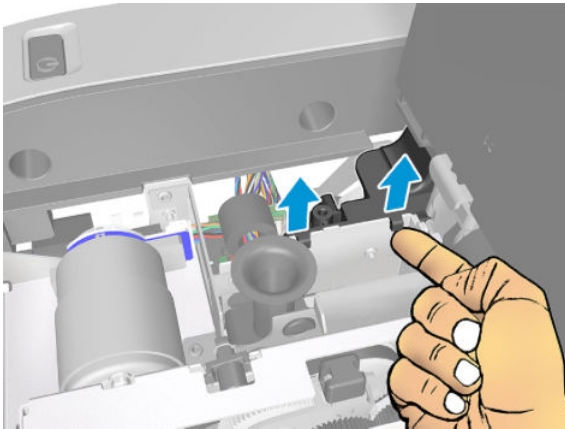

18. Remove the bracket cable.

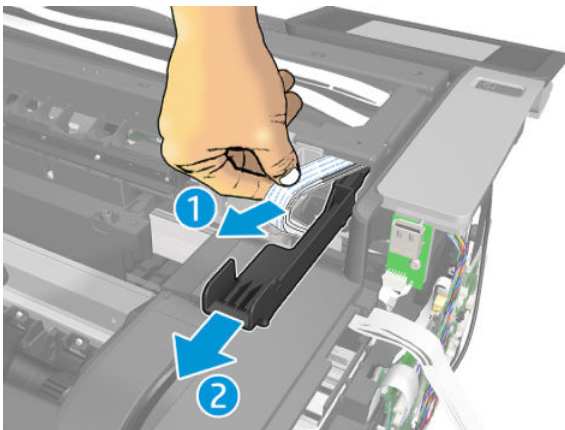

19. Remove the three ferrites and cables from the bracket.

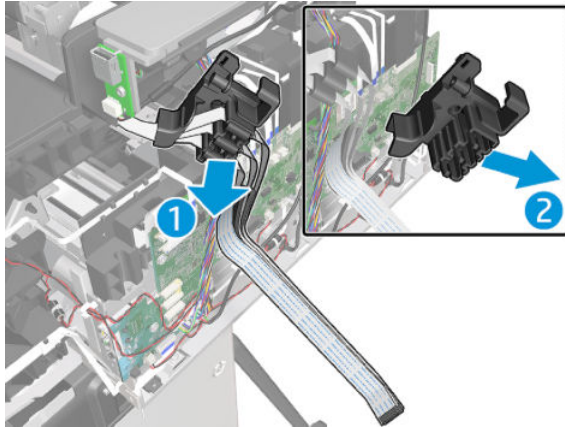

20. Gently pass the three FFC Cables through the hole.

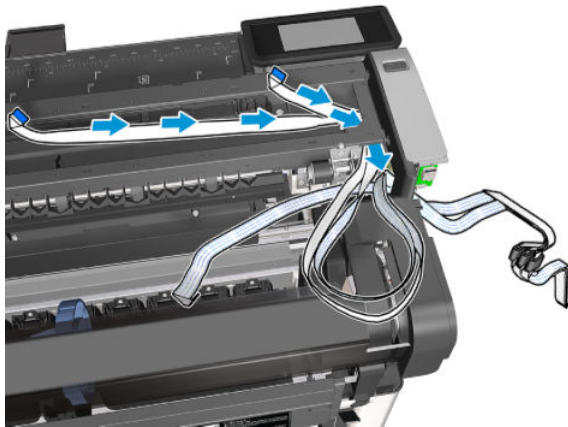

21. Remove the scanbar FFC.

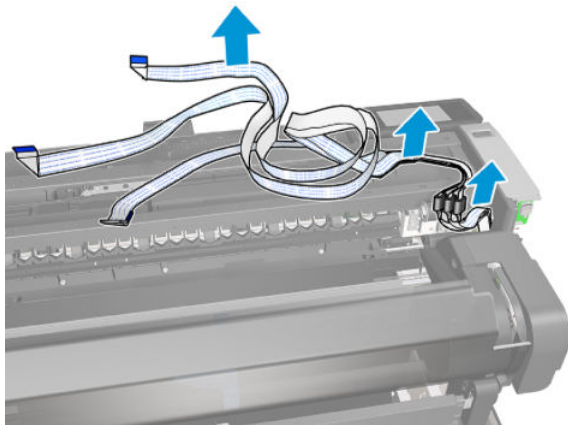

## Installation

1. Install the Scanbar FFC by reversing the removal process.

2. Run scanbar alignment and PRNU compensation.

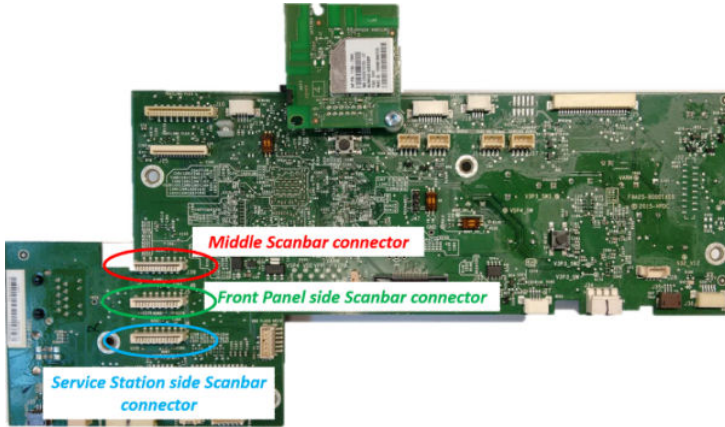

# Printer Sensor Kit SV

## Top Cover Sensor SFP

### Removal

1. Open the Top Cover.



2. Locate the Top Cover Sensor.

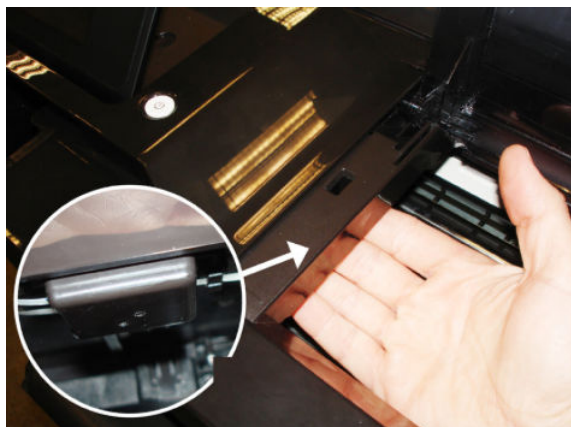

3. Slide the Top Cover Sensor to the left.

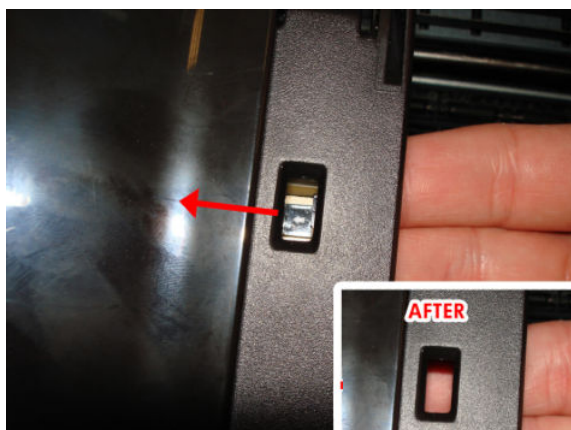

4. Take out the Top Cover Sensor, being careful not to damage the flat cable.



5. Disconnect the flat cable from the Top Cover Sensor.

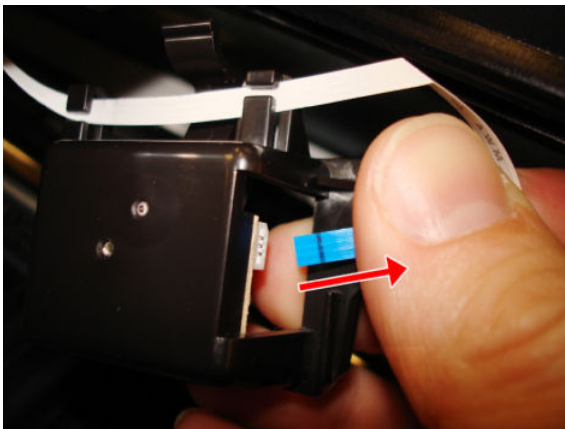

6. Slide the flat cable from the two hooks of the Top Cover Sensor.

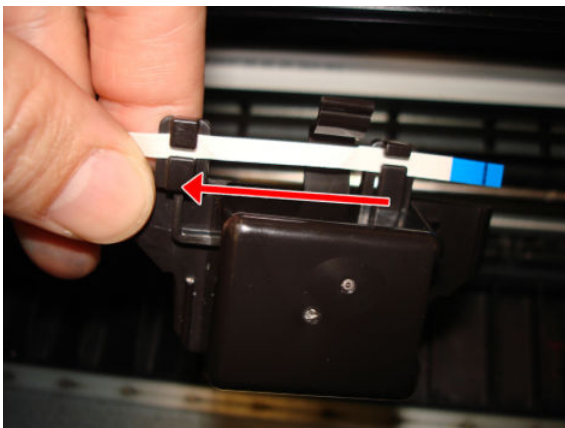

7. Remove the Top Cover Sensor.

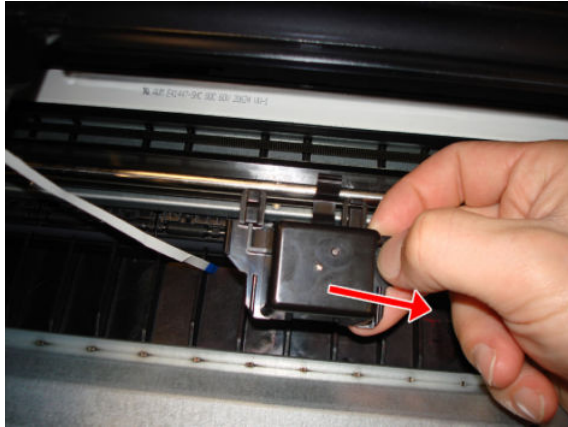

### Installation

1. Be careful with the routing of the cable. If the cable hangs down, it could be broken by the Carriage.
2. Center the sensor in the hole to facilitate the assembly.

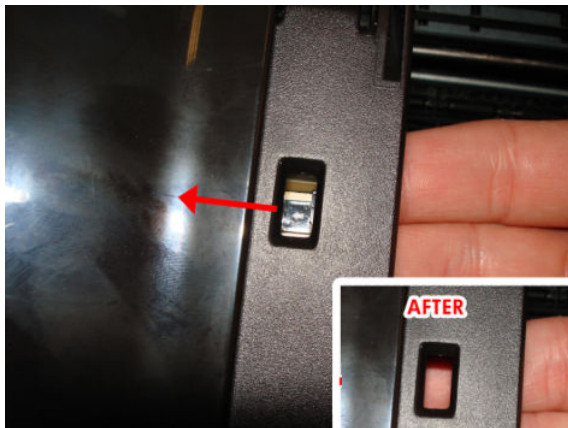

## Top Cover Sensor Cable

### Removal

1. Switch off the printer and remove the power cable.
2. Remove the Front Cover, see [Front Cover on page 261](#).
3. Remove the Cutter Door, see [Cutter Door F9A30-67006 on page 378](#).
4. Remove the Left Cover, see [Left Cover MFP SV Kit F9A30-67012 on page 268](#).
5. Remove the Front Panel, see [Front Panel SFP F9A29-67008 on page 278](#).
6. Remove the Top Cover Sensor, see [Top Cover Sensor SFP on page 473](#).
7. Unroute the flat cable.

 **NOTE:** Image shown is from another product, and for reference only.

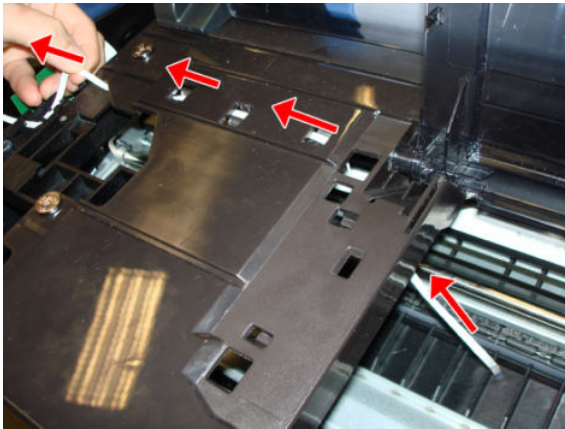

8. Unclip the flat cable.

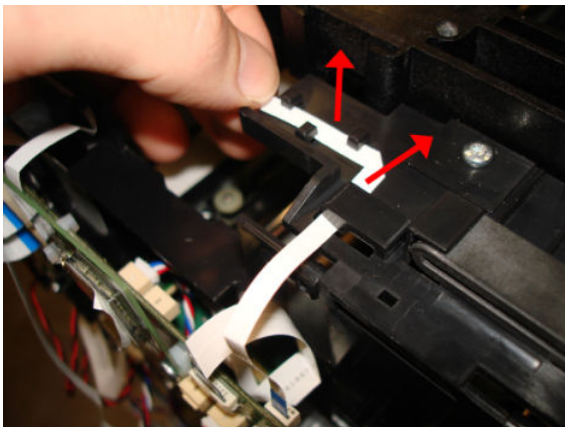



9. Disconnect the flat cable (Top Door Sensor FFC).

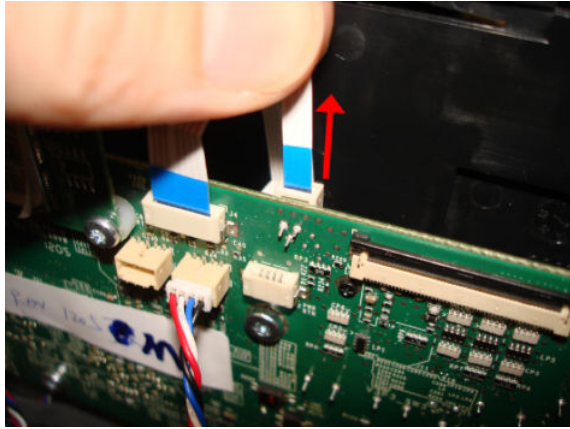

10. Remove the flat cable

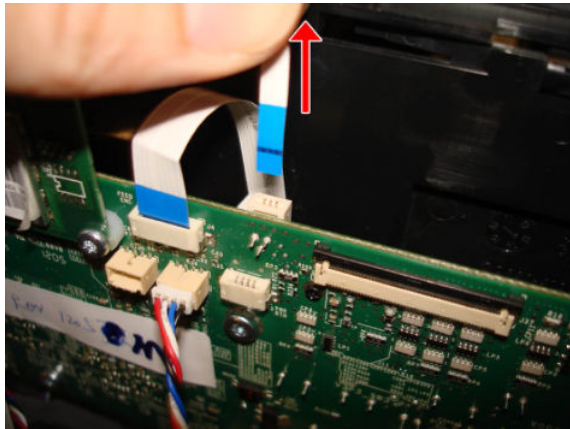

## Installation

- ▲ When routing the flat cable, make sure that you pass it through the 3 hooks, and that the blue-end cable is facing up.

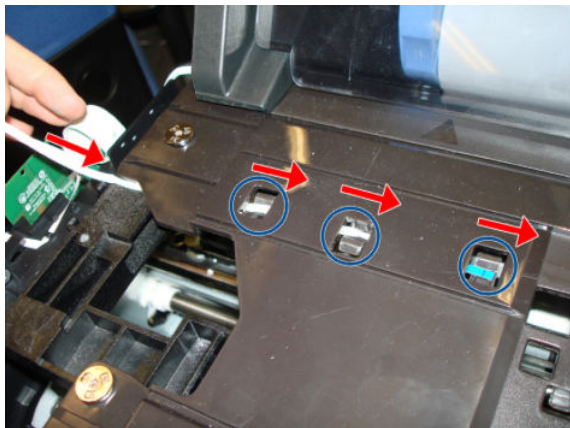

## Front Window Sensor (HP DesignJet T830 MFP only)

### Removal

1. Remove the Left Cover, see [Left Cover MFP SV Kit F9A30-67012 on page 268](#).
2. Remove the Right Cover, see [Right Cover MFP SV Kit F9A30-67011 on page 264](#).
3. Remove the Front Window, see [Front Window MFP SV Kit F9A30-67013 on page 502](#).
4. Disconnect the FFC cable from the Front Window Sensor PCA.

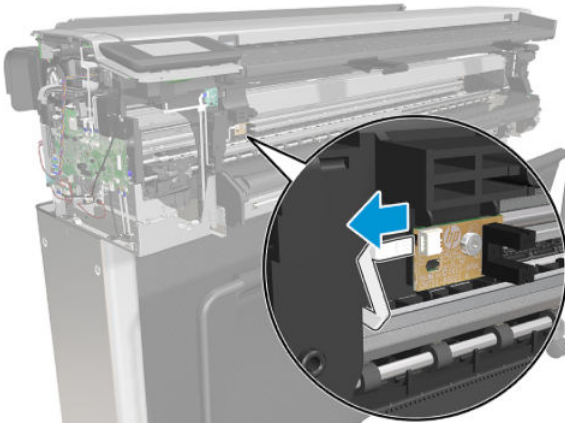

5. Remove one screw.

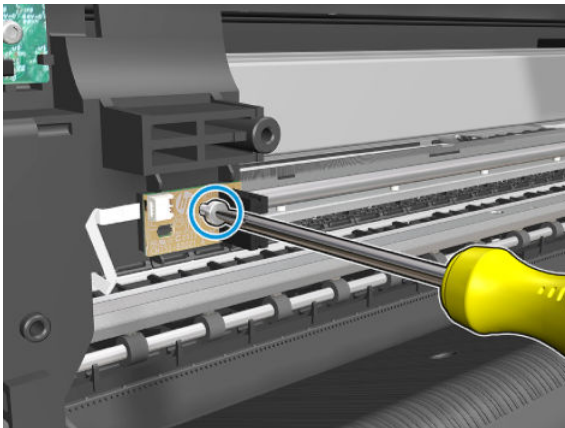

6. Remove the Front Window Sensor PCA.

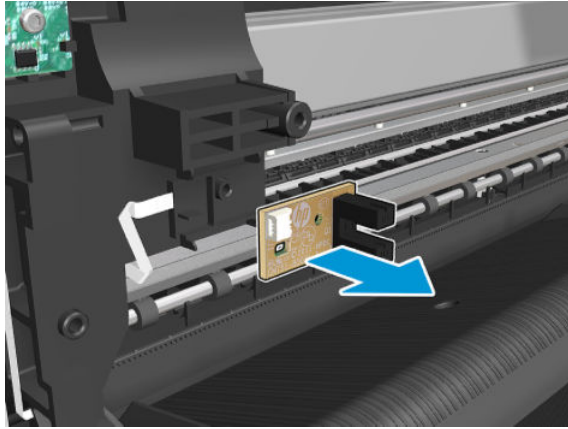

7. Disconnect the cable from the Main PCA and remove it.

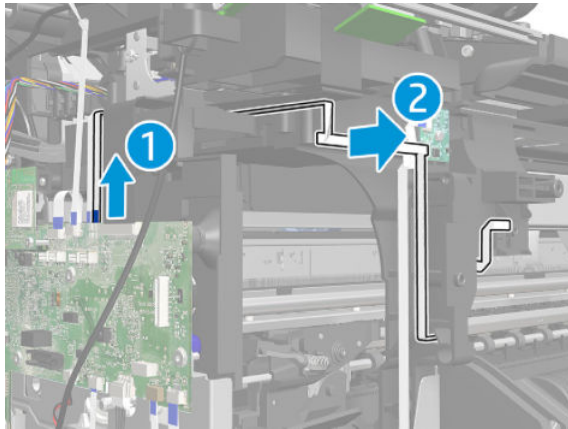

### Installation

- ▲ Install by reversing the removal process.

## Ink Door Sensor

### Removal

1. Remove the Right Cover, see [Right Cover MFP SV Kit F9A30-67011 on page 264](#).
2. Disconnect the FFC cable.

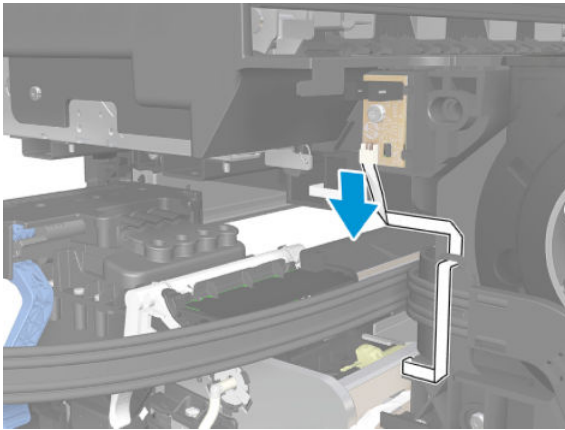

3. Remove one screw.

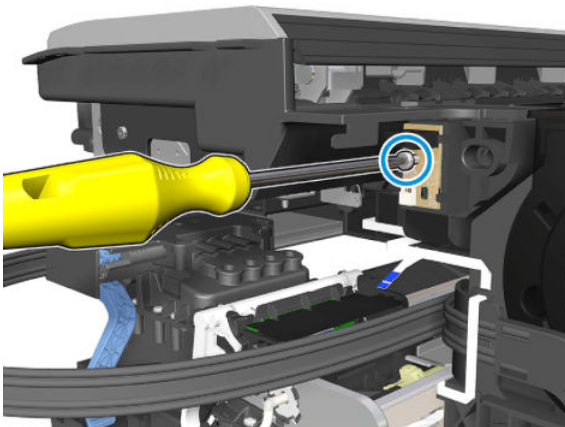

4. Remove the Sensor PCA.

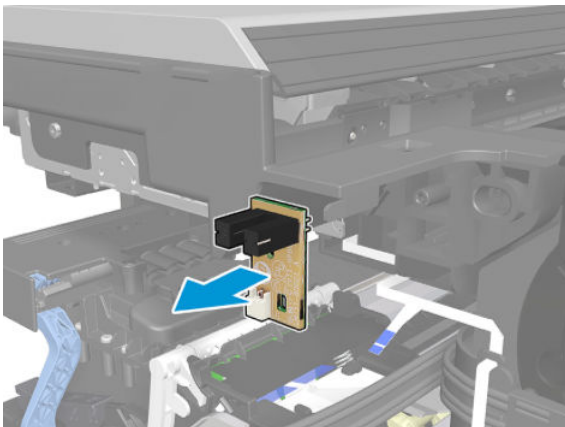

## Installation

- ▲ Install by reversing the removal process.



---

**NOTE:** Make sure the cable's blue stripe is not visible from the front.

---

## PHA Door Sensor

### Removal

1. Remove the Right Cover, see [Right Cover MFP SV Kit F9A30-67011 on page 264](#).
2. Disconnect the FFC cable.

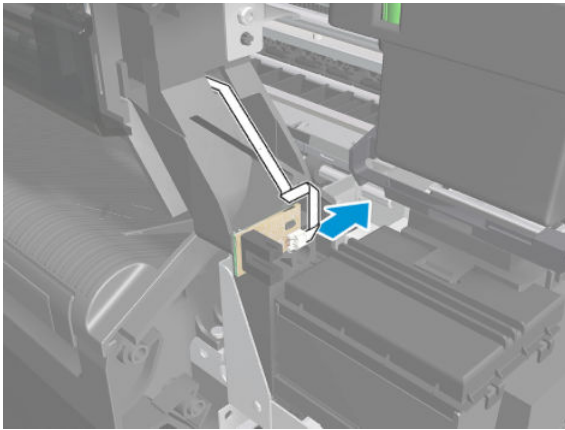

3. Remove one screw.

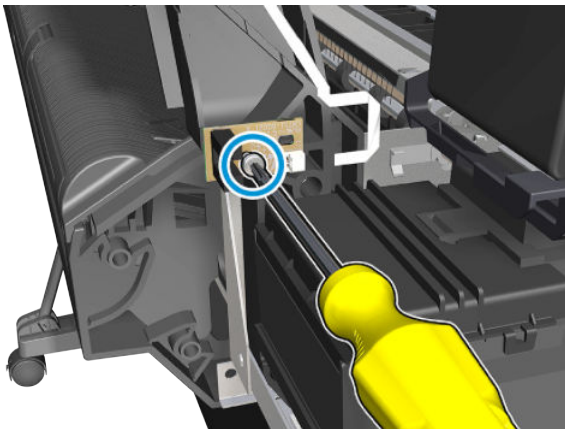

4. Remove the Sensor PCA.

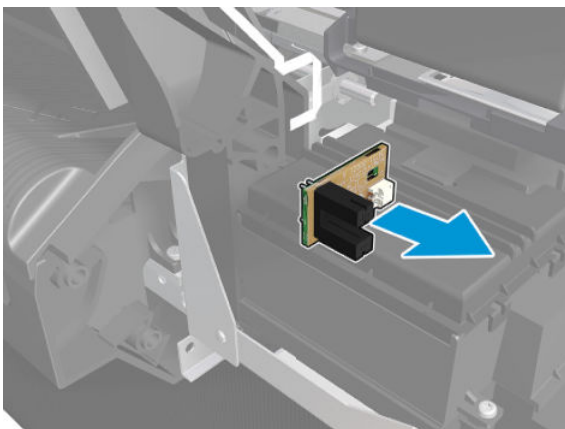

## Installation

- ▲ Install by reversing the removal process.



---

**NOTE:** Make sure the blue stripe is not visible from the front.

---

# Calibration Surface F9A30-67027

## Removal

1. Remove the Bottom Plate, see [Bottom Platen F9A30-67042 on page 431](#).
2. Note the location of the 3 Calibration Surfaces.

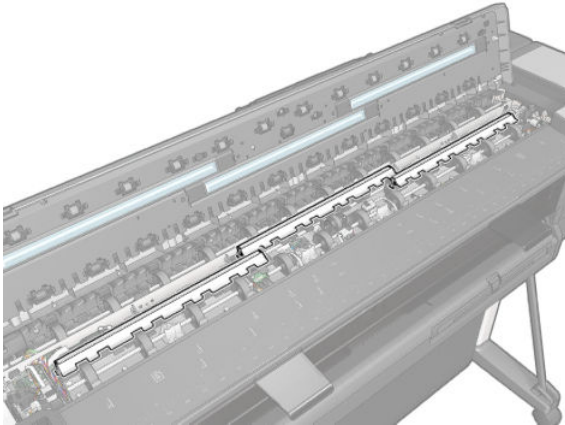

3. Press both sides to unclip one.

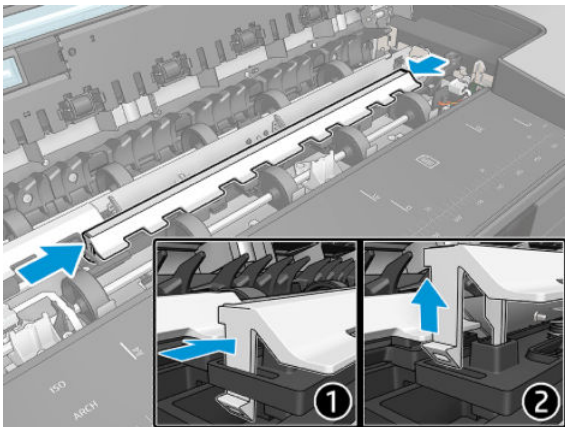

4. Remove the Calibration Surface.

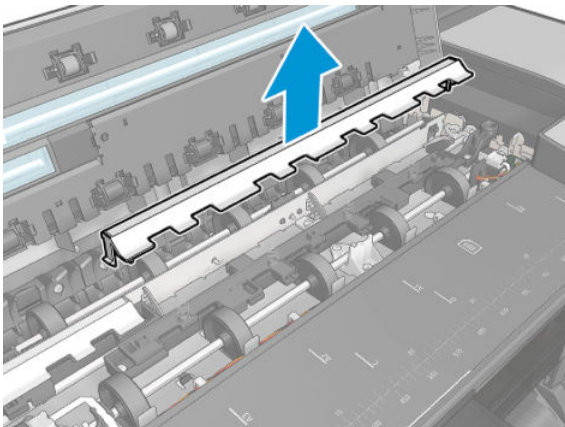



## Installation

1. Insert the 3 Calibration Surface pins in their holes.

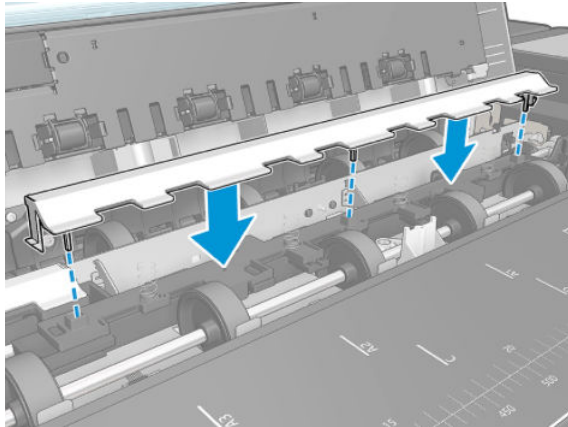

2. Be sure the 4 springs are correctly positioned.

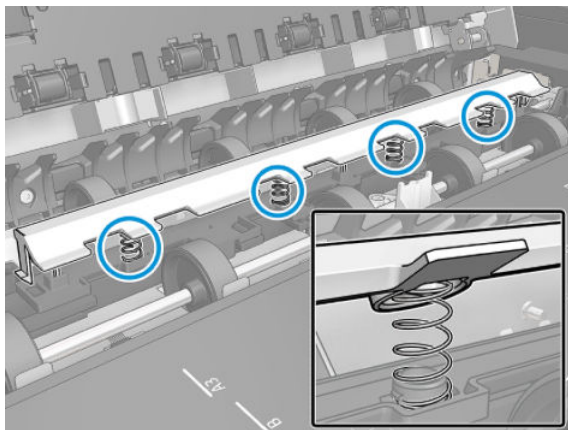

3. Check the Calibration Surface works properly.

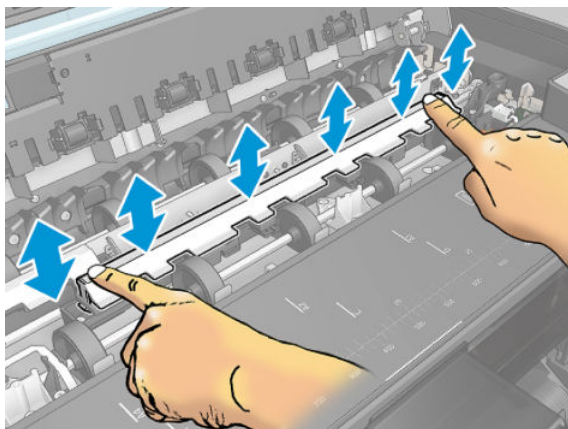

4. Calibration surface replacement checklist:
  - a. Replace all 3 calibration surfaces.
  - b. Clean the scanbars.

- c. Remove films.
- d. Boot the unit.
- e. Promote PRNU to Pristine (from Extended Support Menu).
- f. Run Scanbar alignment calibration.
- g. Restore Scanner Calibrations (from Extended Support Menu).

---

 **NOTE:** Calibration surface kit includes 3 calibration surfaces.

---

# Calibration Slider

 **IMPORTANT:** Always change all three sliders.

---

## Removal

1. Remove the Bottom Platen, see [Bottom Platen F9A30-67042 on page 431](#).
2. Remove two screws.

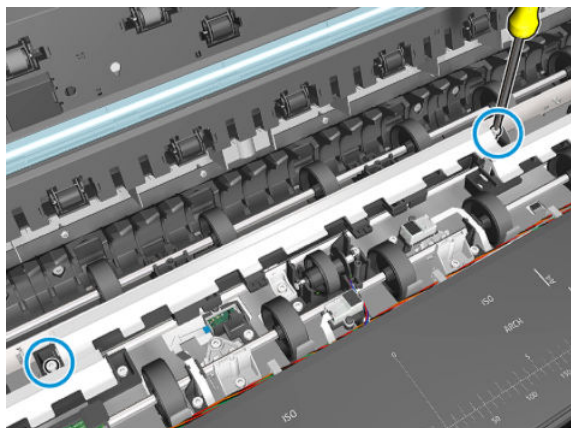

3. Rotate the Calibration slider to unclip it from the 2 holes(only the middle module).

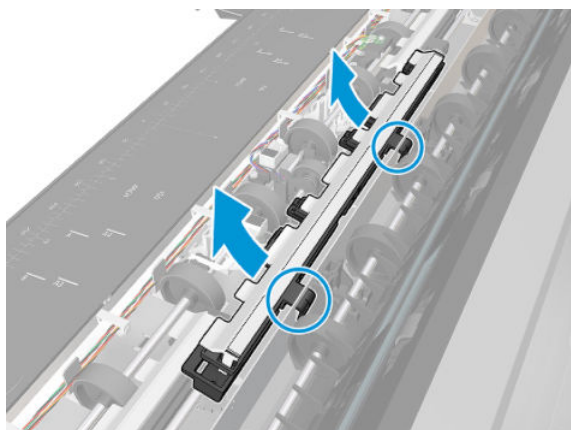

4. Remove the Calibration slider.

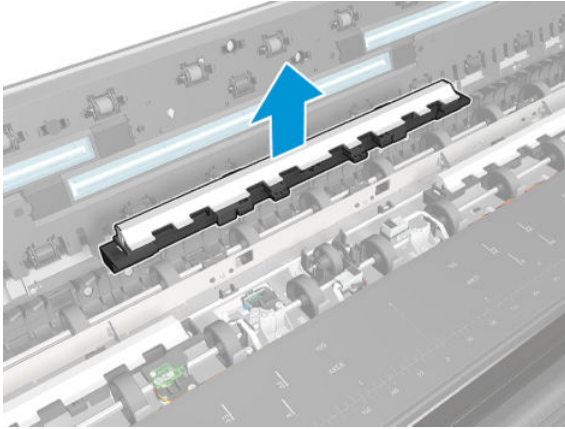

### Installation

1. Install the Calibration Slider by reversing the removal process.
2. Calibration Slider replacement checklist:
  - a. Replace all 3 calibration sliders
  - b. Clean the scanbars.
  - c. Remove films.
  - d. Boot the unit.
  - e. Promote PRNU to Pristine (from Extended Support Menu).
  - f. Run Scanbar alignment calibration.
  - g. Restore Scanner Calibrations (from Extended Support Menu).

---

 **NOTE:** Calibrations Slider SV kit includes only 1 calibration slider. Calibration surface SV kit contains 3 calibration surfaces.

 **NOTE:** Pay attention to the position of the shaft cam when assembling the calibration slider.

---

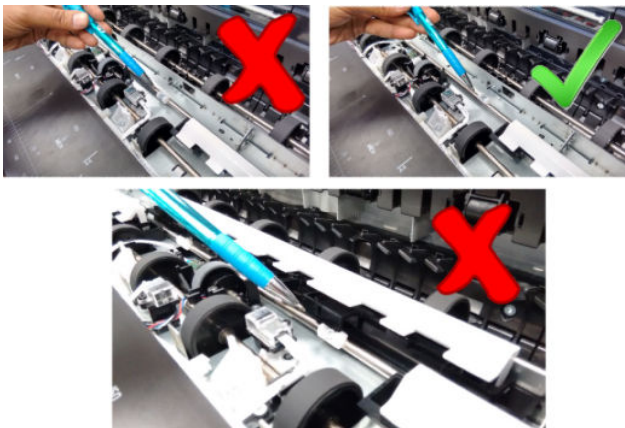

# Calibration Surface Gear Train F9A30-67028

## Removal

**Tools:** Screwdriver Torx 10

1. Remove the right cover, see [Right Cover MFP SV Kit F9A30-67011 on page 264](#)
2. Remove the top right cover.
3. Remove the Bottom Platen, see [Bottom Platen F9A30-67042 on page 431](#).
4. Remove one screw.

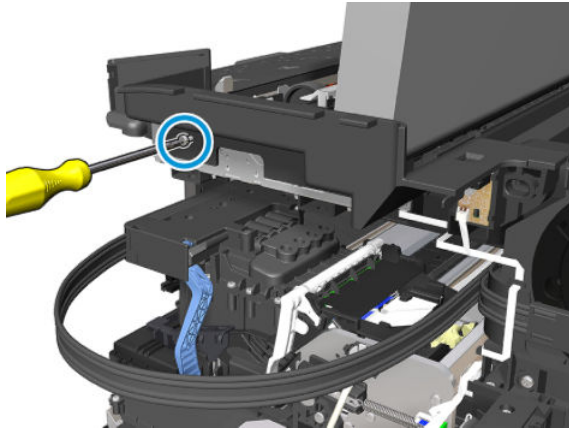

5. Rotate the Scanner Top Cover and remove the Top Right Cover.

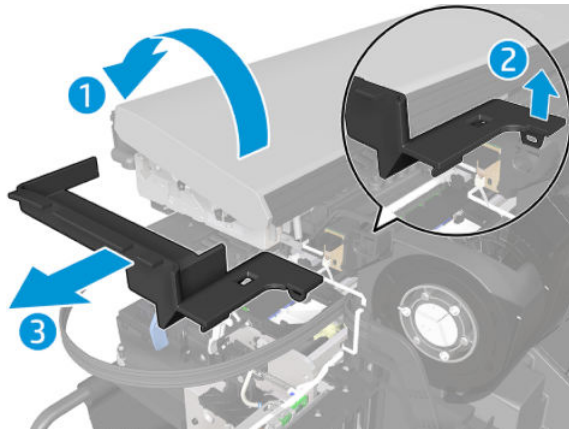

6. Remove the Spring gear slider.

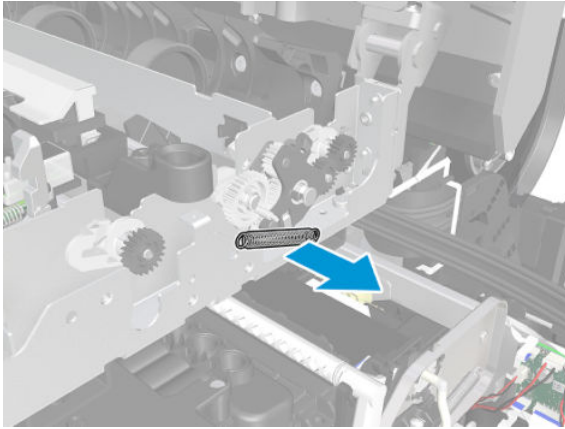

7. Cut the two gear train clips.

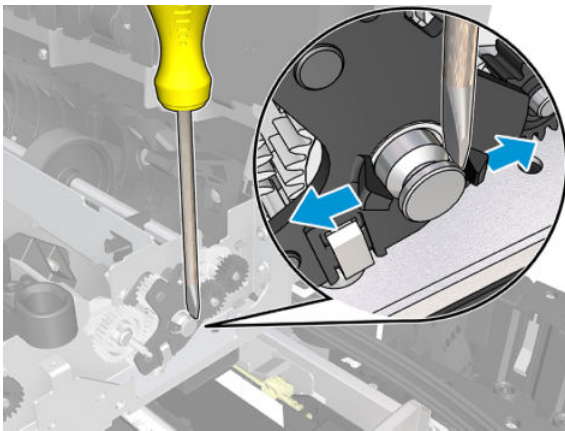

8. Carefully detach the gear.

**⚠ CAUTION:** Take special care not to break it.

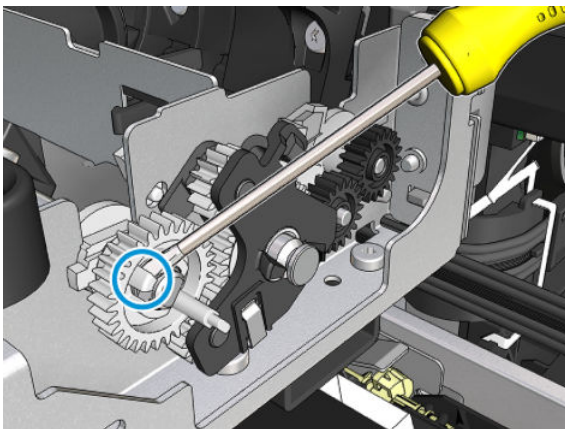

9. Remove the gear.

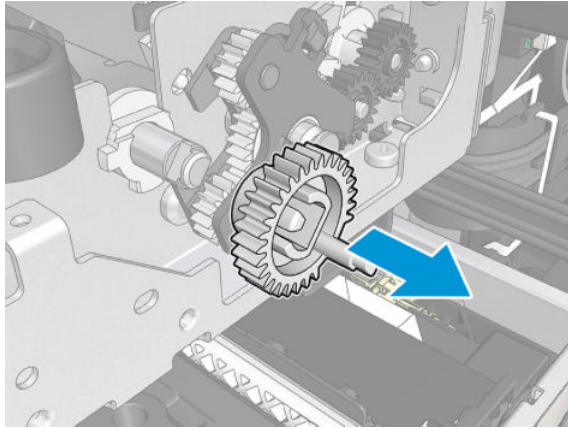

10. Remove the Cal Surface Gear Train.

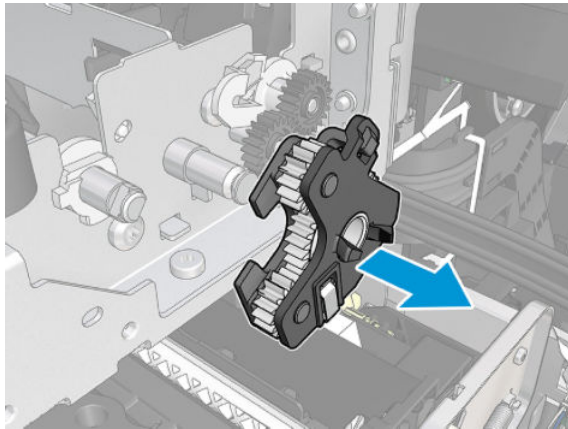

11. Remove the small gear.

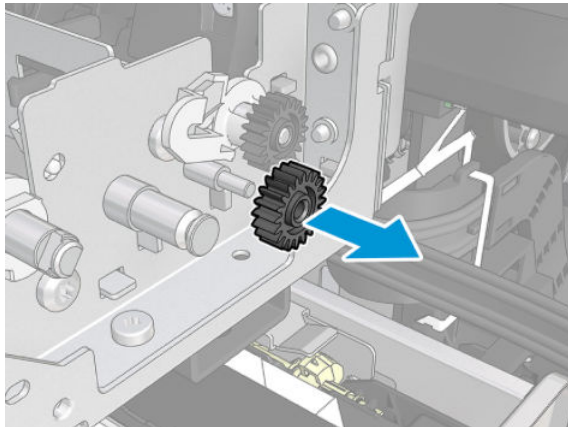

## Installation

- ▲ Install the Calibration Surface Gear Train by reversing the removal process.

# Lower Pinch Assembly with Mirror F9A30-67033 (HP DesignJet T830 MFP only)

## Removal

1. Open the Front Window.

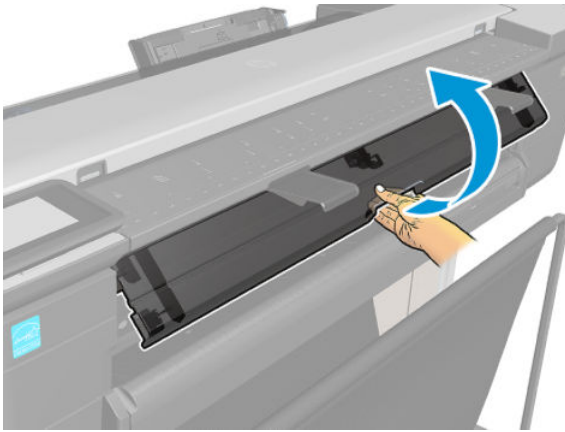

2. Locate the Lower Pinch Assembly.

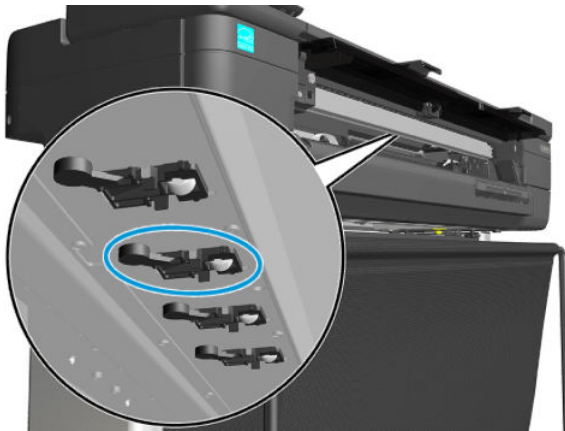



3. Slide the Lower Pinch Assembly by pushing it away from you and towards the printer, and take it out from the printer.

 **TIP:** The pinches can be seen in the scanner output path.

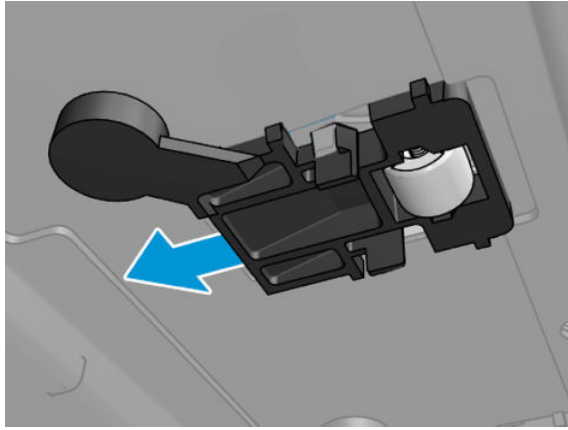

4. Remove the Lower Pinch Assembly.

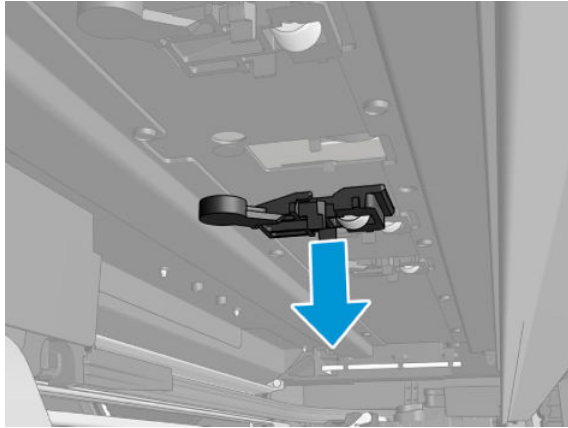

## Installation

- ▲ Install the Lower Pinch Assembly with Mirror by reversing the removal process.

 **NOTE:** The Lower Pinch Assembly position can be estimated based on the input platen mark.

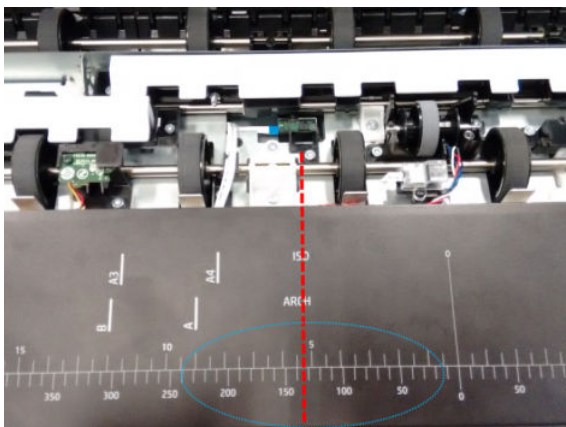

# RIDS (Ink Tubes)

## Removal

1. Remove the Right Cover, see [Right Cover MFP SV Kit F9A30-67011 on page 264](#).
2. Remove the two screws.

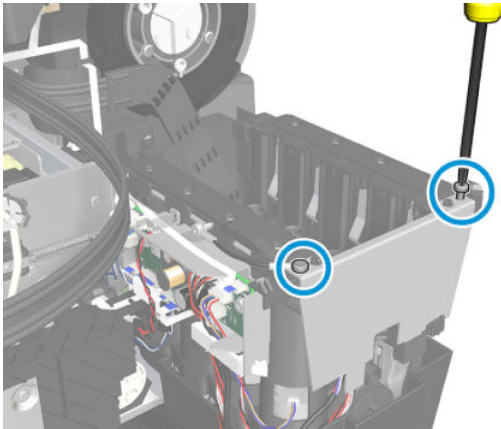

3. Unlatch the Ink Tubes.

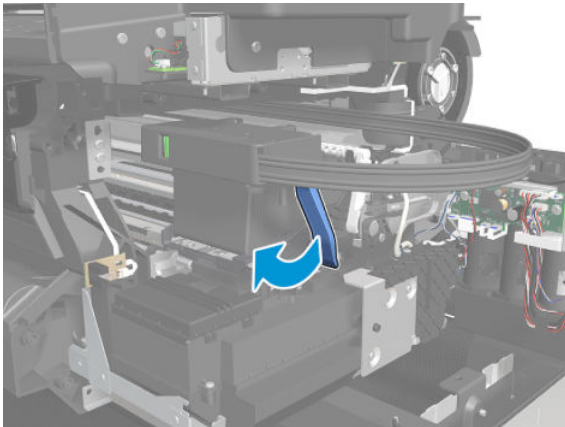

4. Place the Ink Tubes in the Ink Supply Station area.

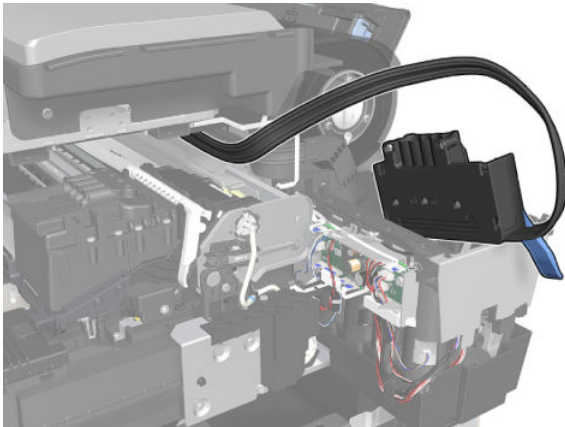

5. Remove the two sensor cables and detach the locator from the Printer Bundle Board support.

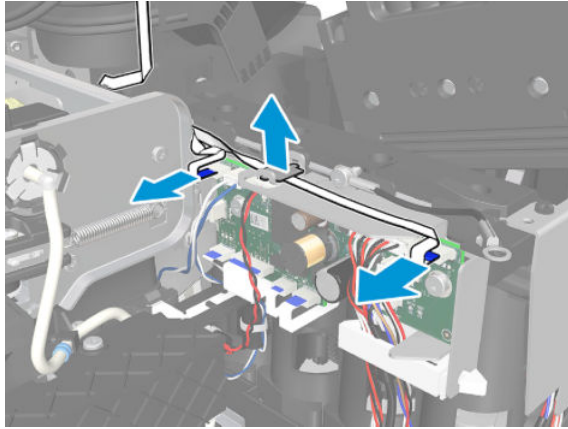

6. Unroute the two sensor cables.

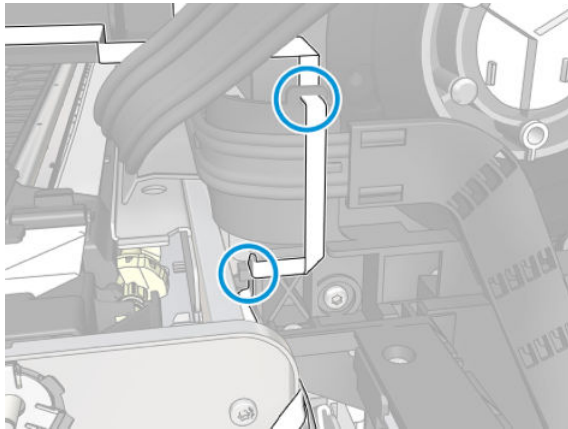

7. Remove the Raceway from the two hooks.

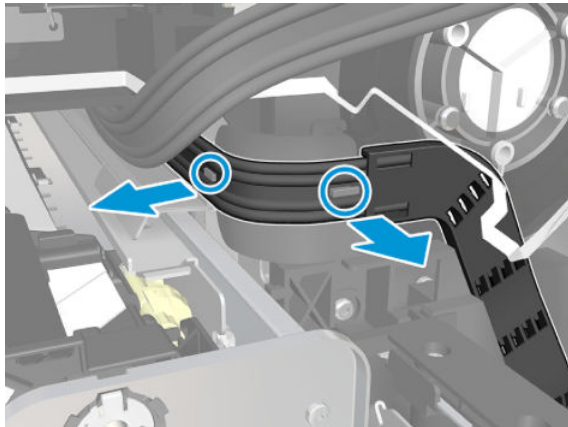

8. Open the Front Window.

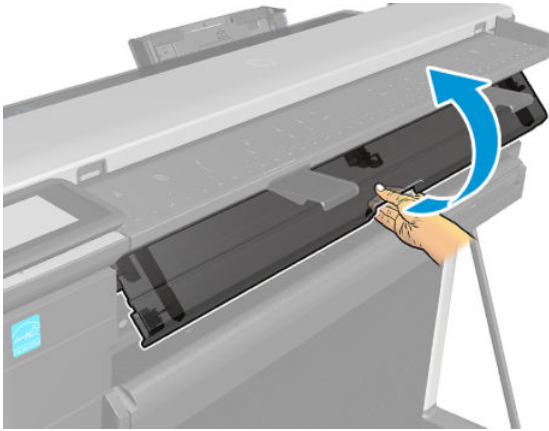

9. Insert a piece of paper.

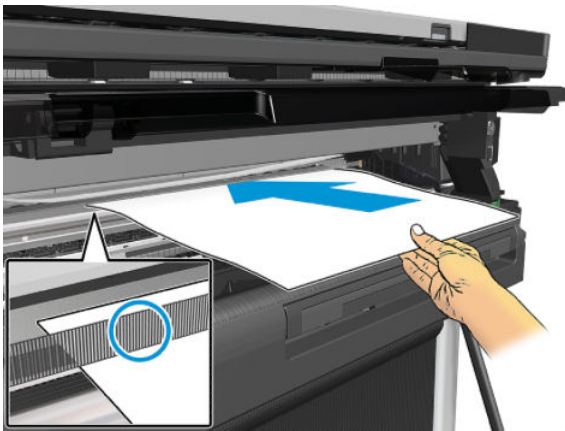

10. Remove the Raceway Holder.

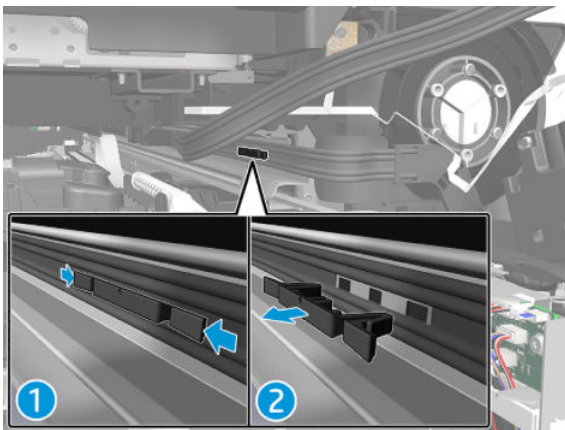

11. Remove the Raceway Router.

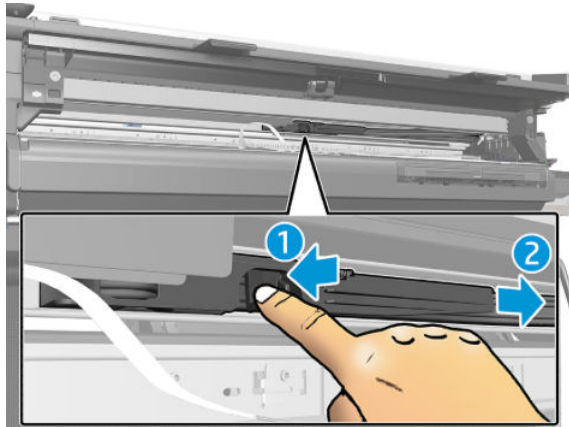

12. Leave the Raceway Router on the paper.

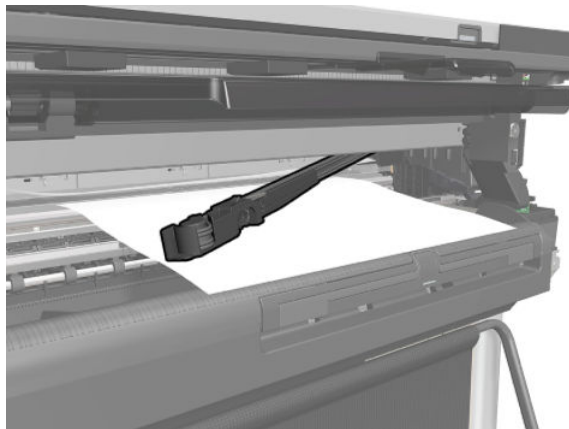

13. Leave the Ink Tubes Latch hanging.

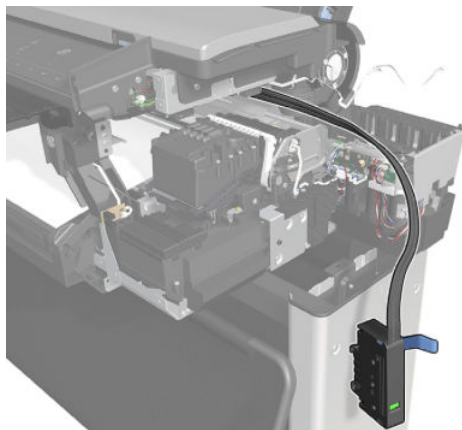

14. Remove the sheet metal wall.

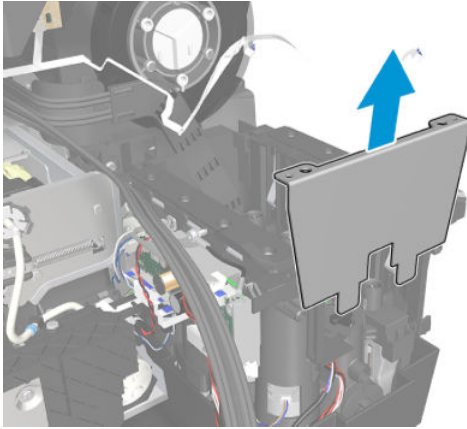

15. Slide the Ink tubes needle mount out of the Ink Supply Station.

**⚠ WARNING!** Ink can drop to the ground from the holes, protect the ground with a cover.

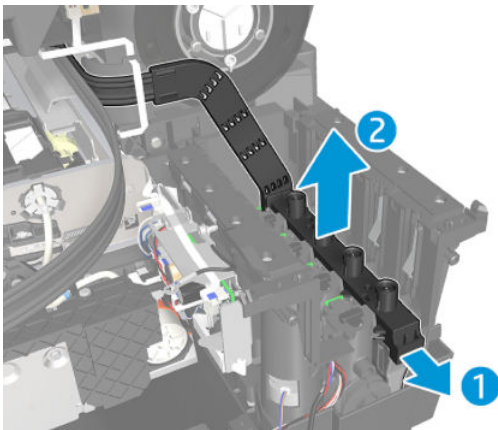

## Installation

- ▲ Install the RIDS by reversing the removal process.

**📝 NOTE:** Make sure to reconnect the grounding cable.

**📝 NOTE:** Make sure the Needle Mount is sliding in X and the sheet metal wall is assembled vertically.

**📝 NOTE:** Check the encoder strip for any grease transfer and clean it if required.

# ISS

## Removal

1. Remove the Right Cover, see [Right Cover MFP SV Kit F9A30-67011 on page 264](#).
2. Disconnect the 3 harness cables and unrout them.

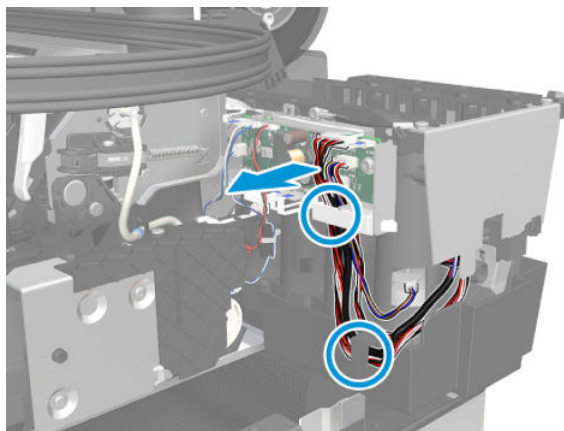

3. Remove the two screws.

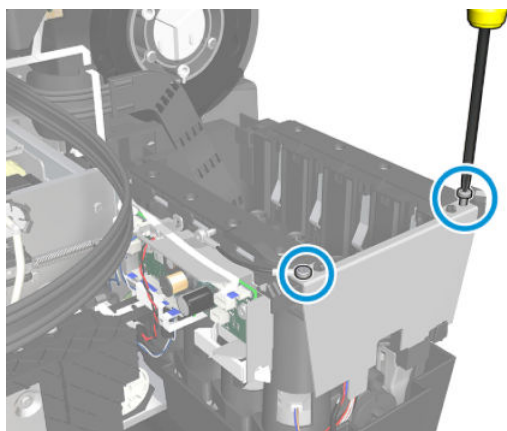

4. Remove the metal part.

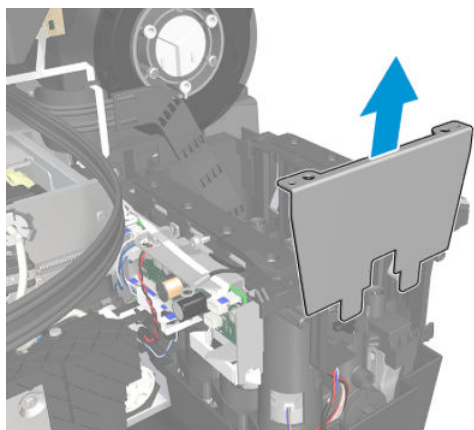

5. Slide and unclip.

**⚠ WARNING!** Ink can drop to the ground from the holes, protect the ground with a cover.

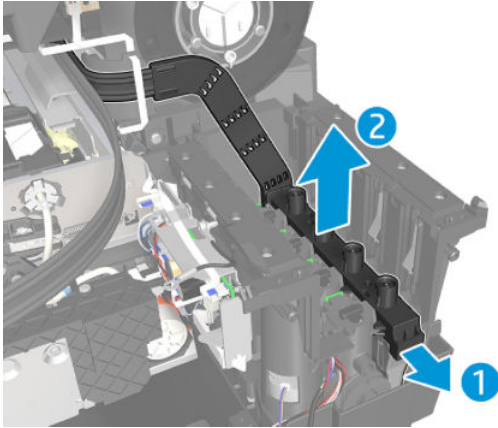

6. Remove the two screws.

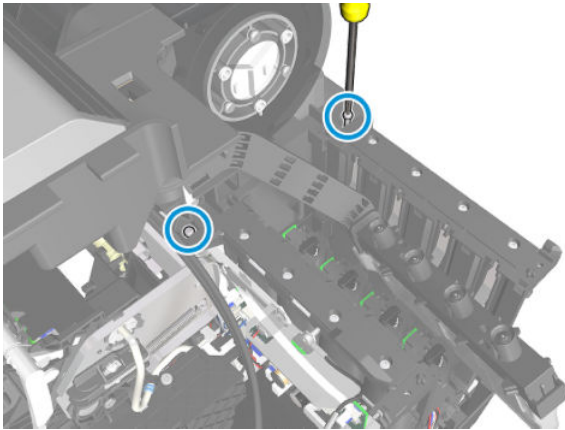

7. Unhook the ISS.

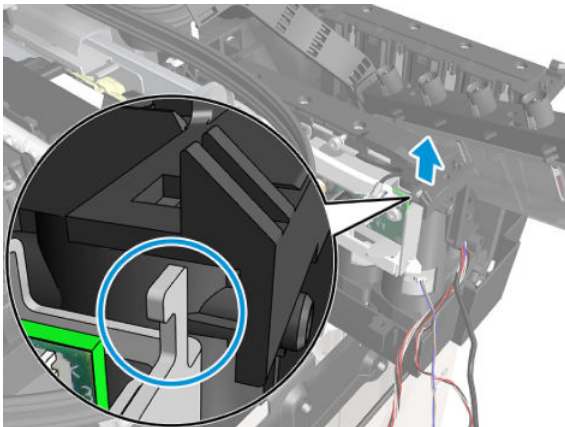



8. Remove the ISS.

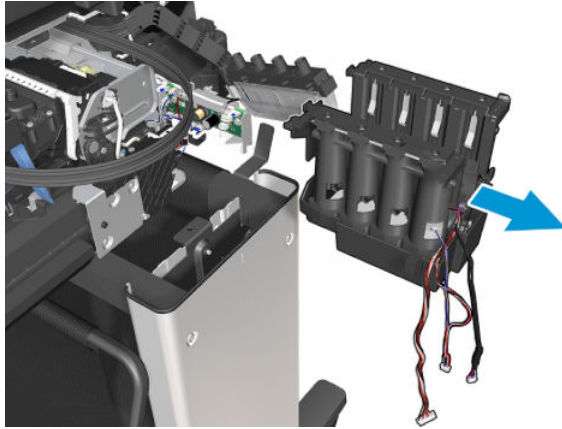

## Installation

- ▲ Install the ISS by reversing the removal process.

 **IMPORTANT:** Make sure the metal part is installed vertically and take care the needle mount is aligned with the ISS lifter.

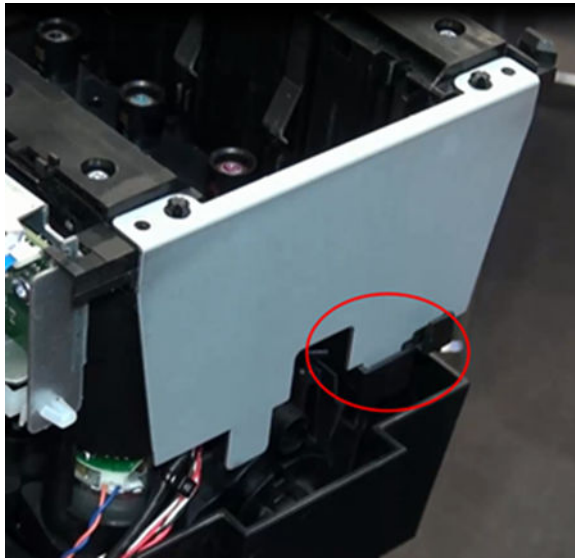

 **IMPORTANT:** Make sure to reinstall the grounding cable.

# Front Window MFP SV Kit F9A30-67013

## Removal

1. Remove the Left Cover, see [Left Cover MFP SV Kit F9A30-67012 on page 268](#).
2. Remove the Right Cover, see [Right Cover MFP SV Kit F9A30-67011 on page 264](#).
3. Open the Front Window.

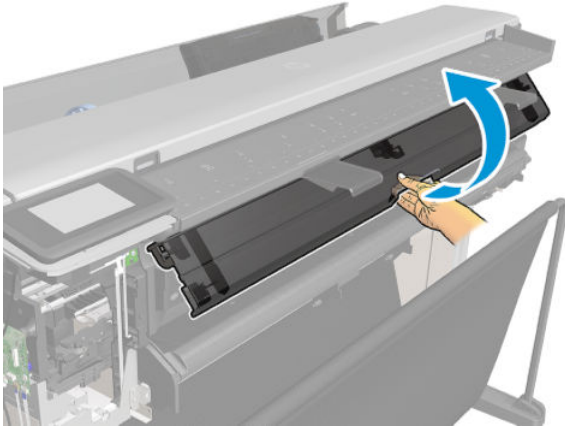

4. Remove two screws.

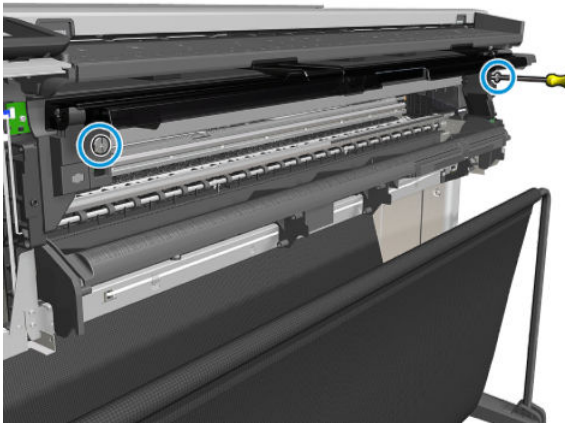

5. Unclip the six snap-fit clips, and remove the Front Window.

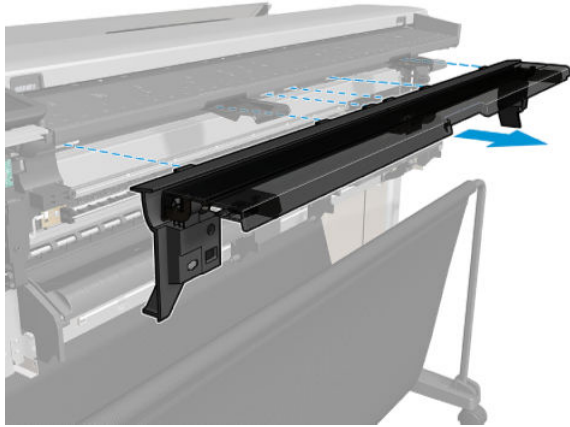

### Installation

- ▲ Install the Front Window by reversing the removal process.

# Refeed Preventer

## Removal

- ▲ Remove the two Refeed Preventers.



## Installation

- ▲ Install the Refeed Preventer by reversing the removal process.

# Scanner Module

## Removal

1. Remove the Rear Cover, see [Rear Cover \(MFP only\) on page 464](#).
2. Remove the Left Cover, see [Left Cover MFP SV Kit F9A30-67012 on page 268](#).
3. Remove the Right Cover, see [Right Cover MFP SV Kit F9A30-67011 on page 264](#).
4. Remove the Front Window, see [Front Window MFP SV Kit F9A30-67013 on page 502](#).
5. Remove the Refeed Preventer, see [Refeed Preventer on page 504](#).
6. Disconnect the three cables.

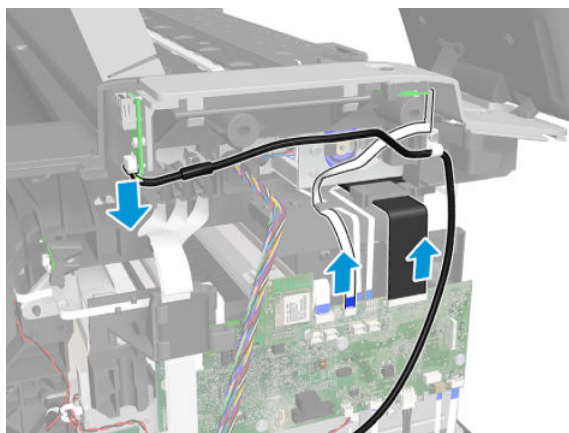

7. Detach the FFC Power Button.

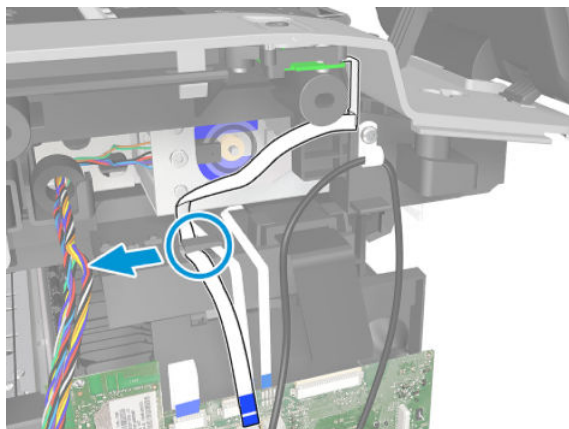

8. Remove the three screws.

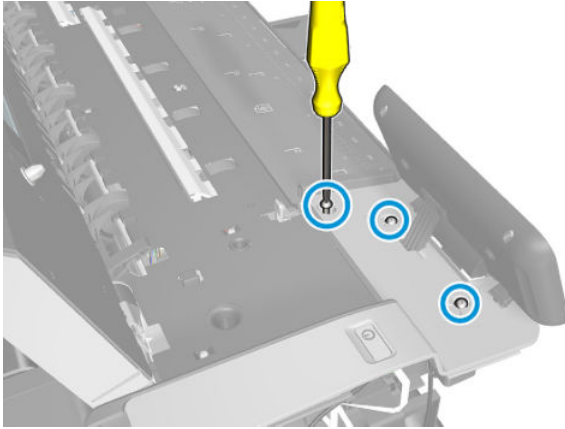

9. Unclip the four clips.



**NOTE:** The Top Left Cover (where the front panel support clips are) can also be removed to reduce the risk of scanner cable damage.

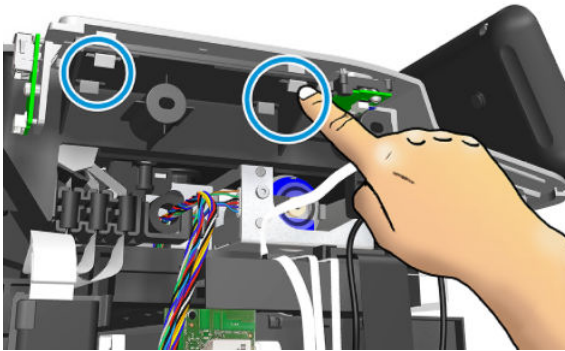

10. Leave the Front Panel in "parking" position.

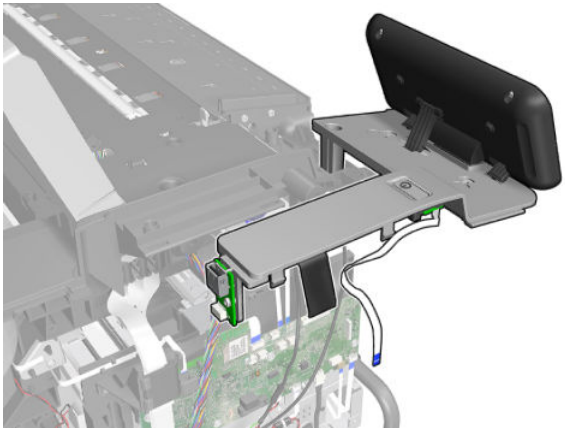

11. Remove one screw.

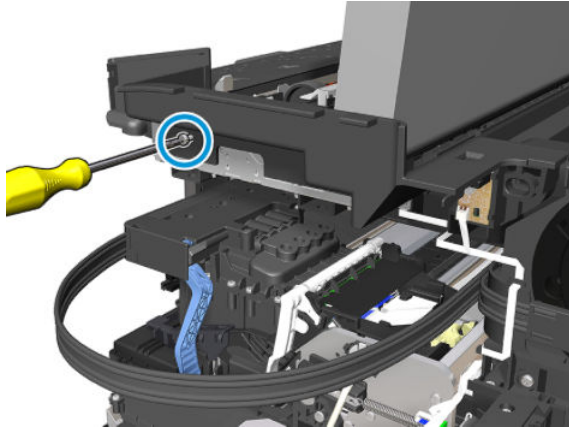

12. Rotate the Scanner Top Cover and remove the Top Right Cover.

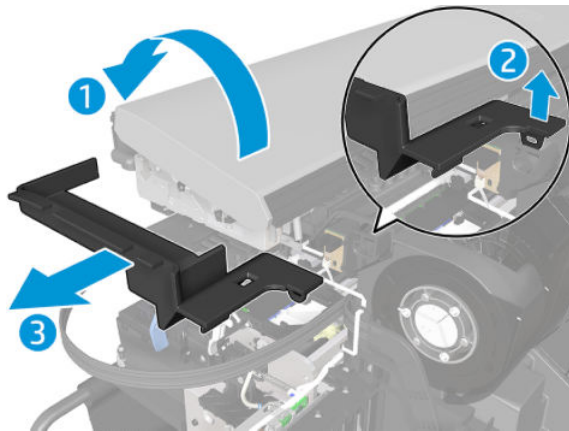

13. Remove two screws.

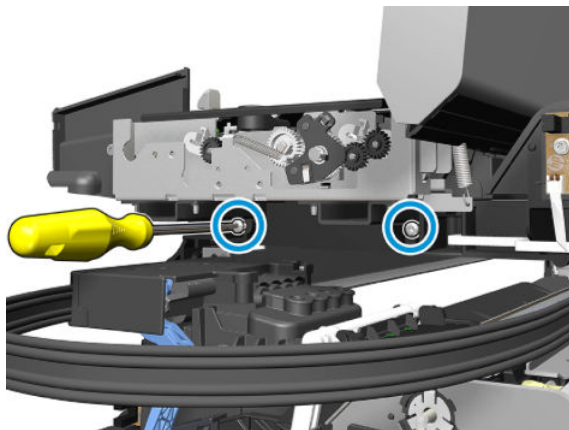

14. Remove one screw.

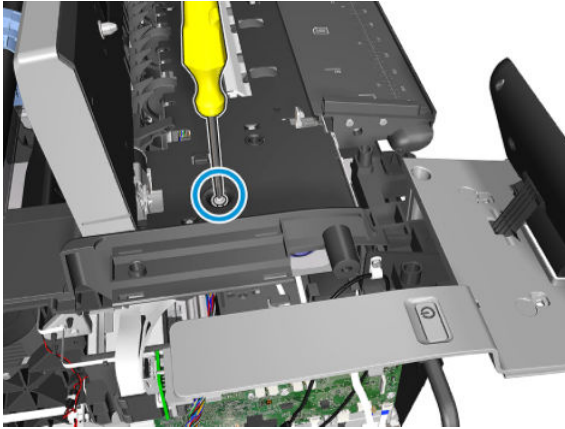

15. Disconnect the two cables.

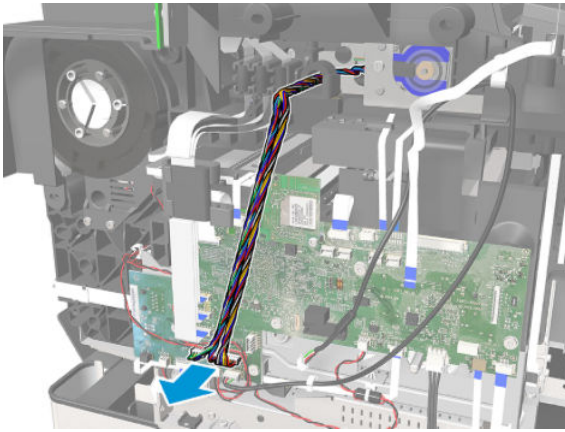

16. Disconnect the three FFC cables.

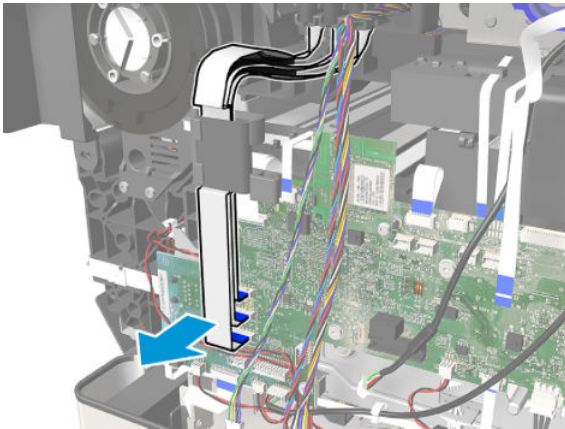



**17.** Remove one screw.

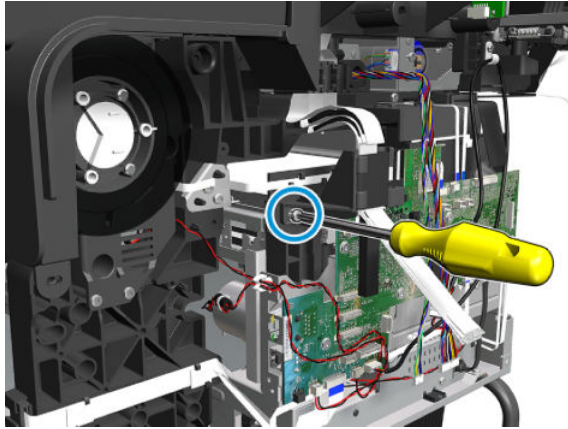

**18.** Remove the holder and the ferrite.

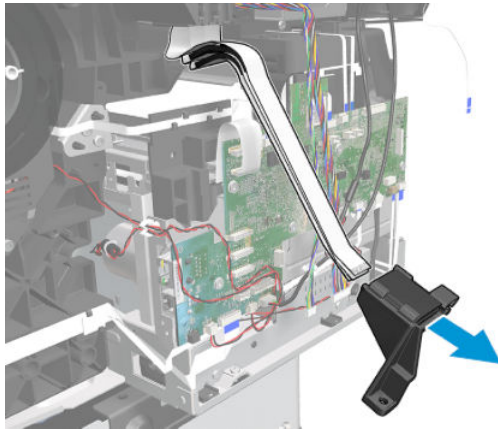

**19.** Close the Scanner.

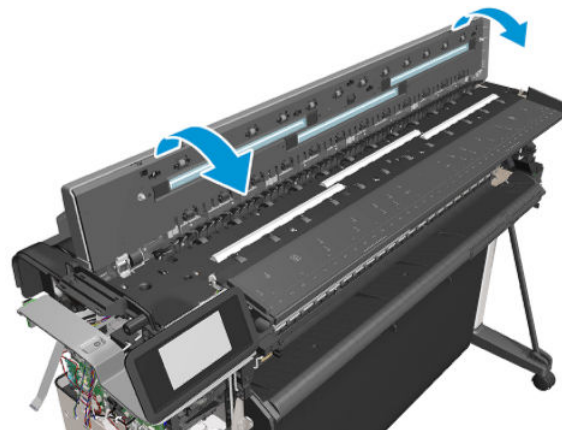

20. Remove the Scanner Module.

**⚠ CAUTION:** Take care not to damage the cables.

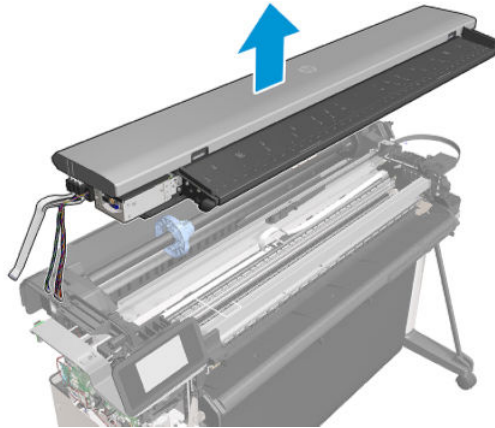

**Installation**

1. **Attention:** When installing, be careful to install the Front Panel and the Left Trim correctly.

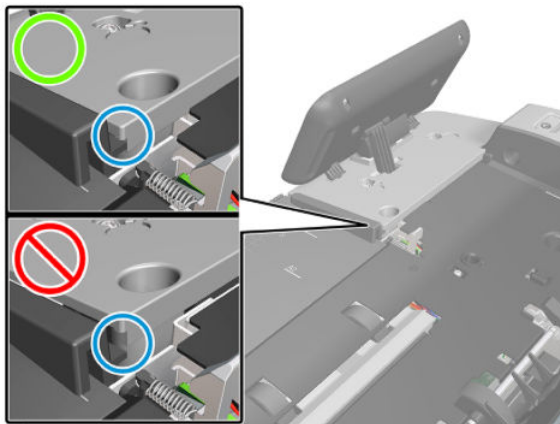

2. Install the Scanner Module by reversing the removal process.

# Top Lid Mirror and Magnet (HP DesignJet T830 MFP only)

## Removal

1. Open the Scanner.

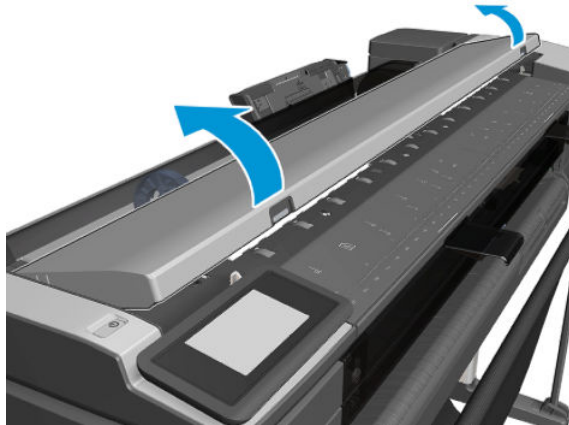

2. Locate the 4 Top Lid Mirrors and 1 Top Lid Magnet.

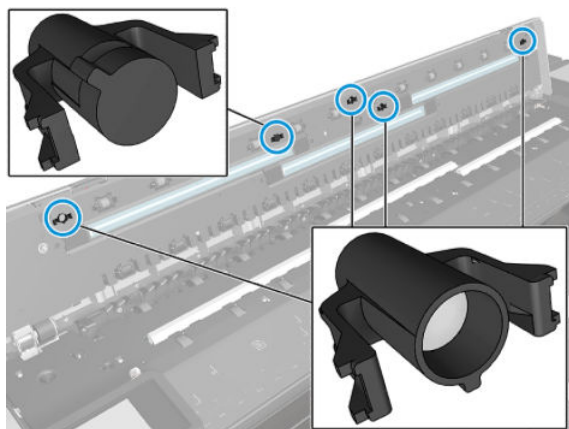

3. Remove the two snap lugs.

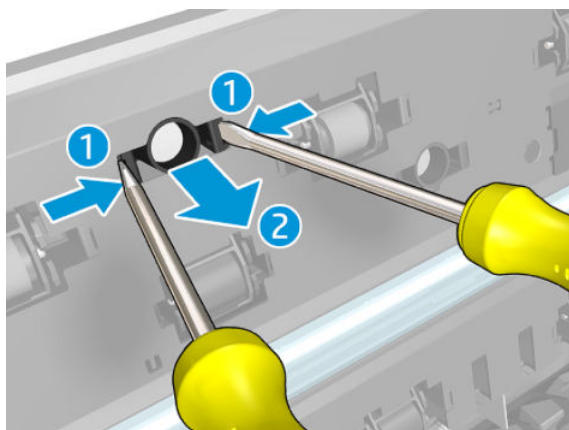

4. Remove the Top Lid Magnet.

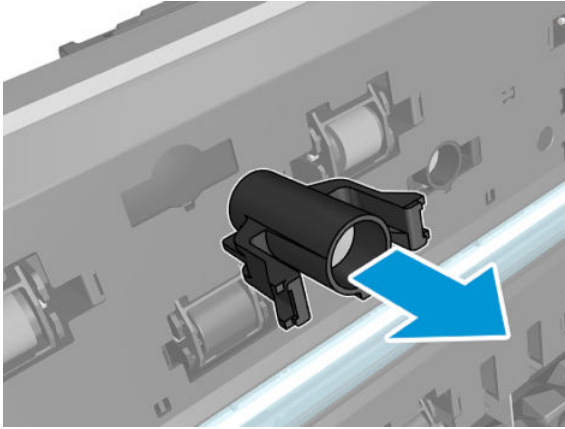

### Installation

- ▲ Install the Top Lid Magnet by reversing the removal process.

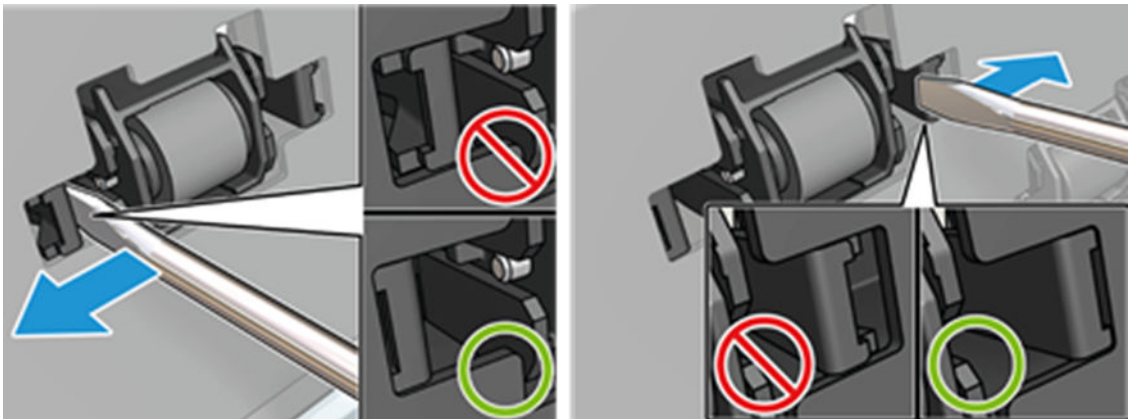

# Input platen SV F9A30-67039 (HP DesignJet T830 MFP only)

## Removal

**Tools:** Screwdriver Torx 10

1. Remove the Front Cover, see [Front Cover on page 261](#).
2. Remove the Right Cover, see [Right Cover MFP SV Kit F9A30-67011 on page 264](#).
3. Remove the Left Cover, see [Left Cover MFP SV Kit F9A30-67012 on page 268](#).
4. Remove the Front Panel and Left Trim, see [Front Panel and Left Trim F9A30-67043 on page 526](#).
5. Remove the two Refeed Preventers, see [Refeed Preventer on page 504](#).
6. Remove the Front Window, see [Front Window MFP SV Kit F9A30-67013 on page 502](#).
7. Remove the Bottom Platen, see [Bottom Platen F9A30-67042 on page 431](#).
8. Slide out the five Guide Paper Output. They are hard to slide out.

 **NOTE:** They do not need to be fully removed.

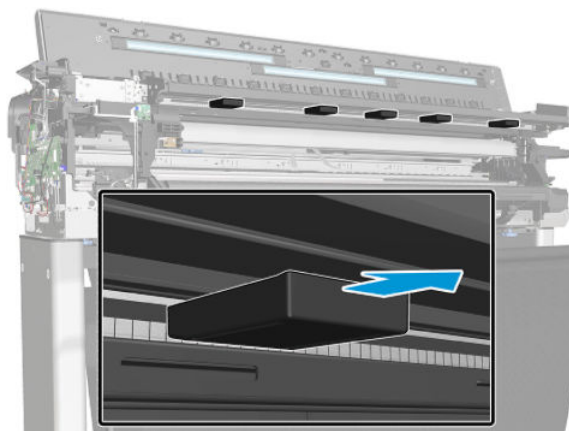

9. Remove one screw from the Lid Magnetic Sensor, and keep it along with the cable and holder, in a save place.

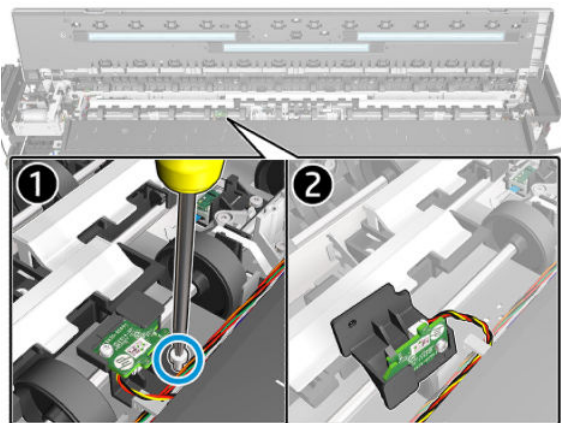

10. Remove two screws.

 **NOTE:** The T10 allen key is included with the Input Platen SV kit.

---

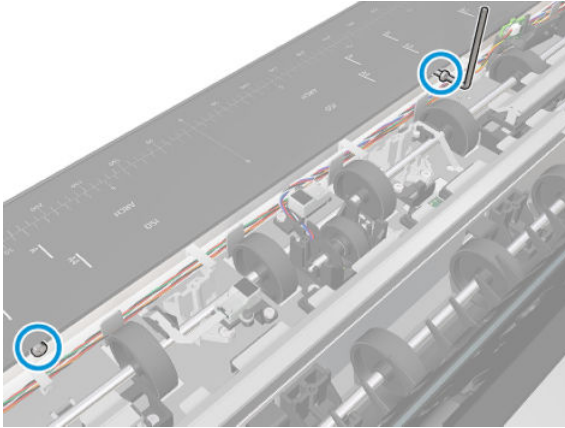

11. Remove one screw.

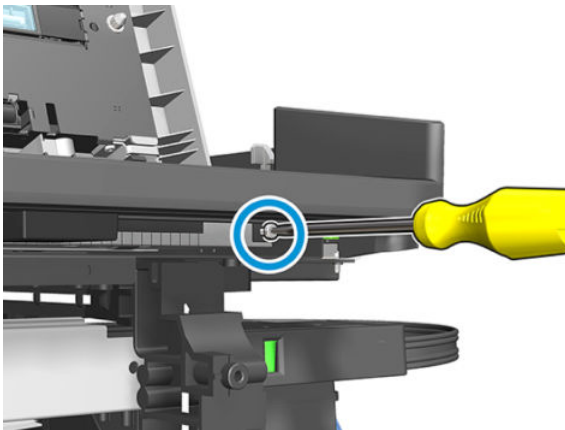

12. Remove three screws.

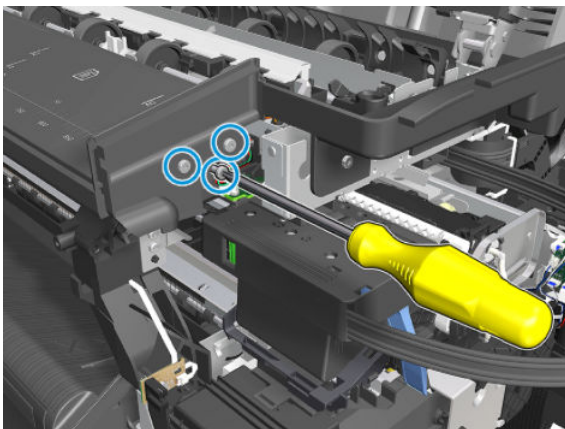

13. Remove one screw.

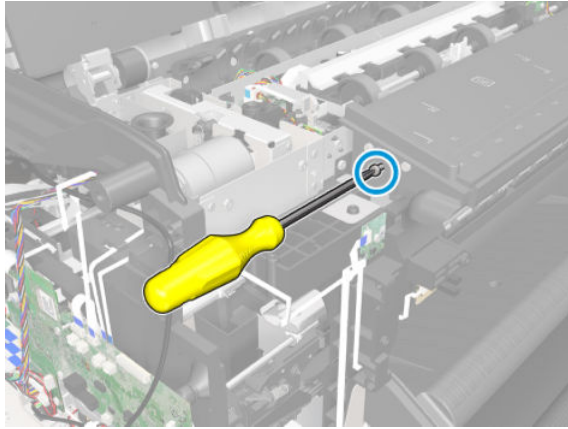

14. Remove the Input Platen. Slide the Input Platen to the left (avoiding diverter sensor) for easy removal.

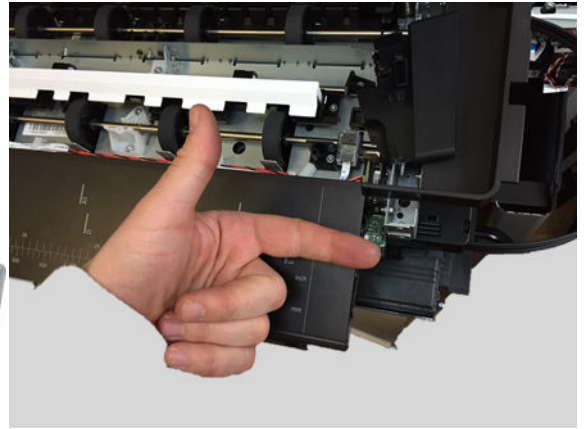
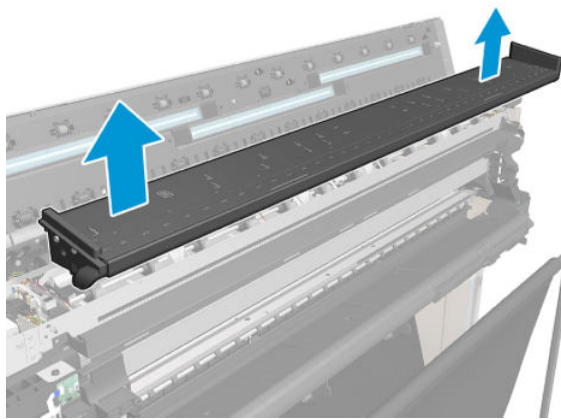

### Installation

- ▲ Install the Input platen by reversing the removal process.

# Diverter SV F9A30-67040

## Removal

**Tools:** Screwdriver Torx 10 and pliers

1. Remove the Right Cover, see [Right Cover MFP SV Kit F9A30-67011 on page 264](#).
2. Remove the Scanner Top Cover, see [Scanner Top Cover F9A30-67015 on page 423](#).
3. Remove the Rear Cover, see [Rear Cover \(MFP only\) on page 464](#).
4. Remove one screw.

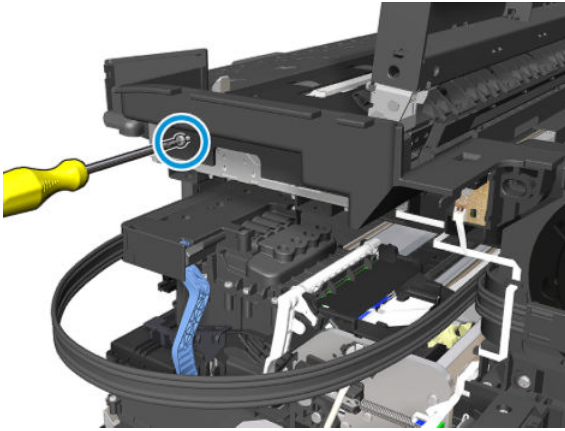

5. Remove the Top Right Cover.

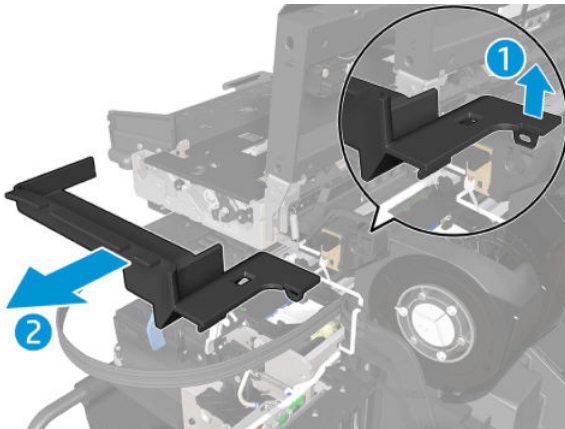



6. Detach the spring from the top and leave it hanging there.

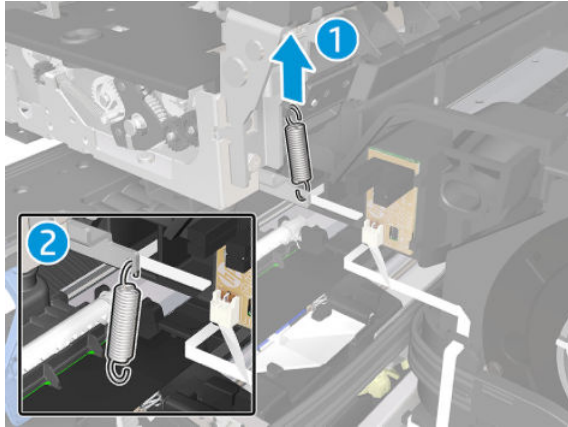

7. Remove one screw.

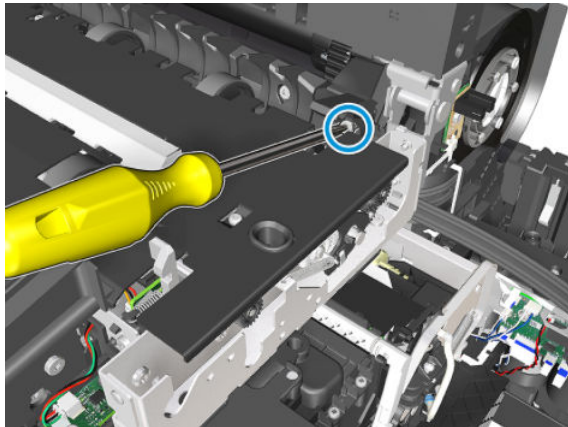

8. Remove the End Plate Right Diverter, it has two positioning pins.

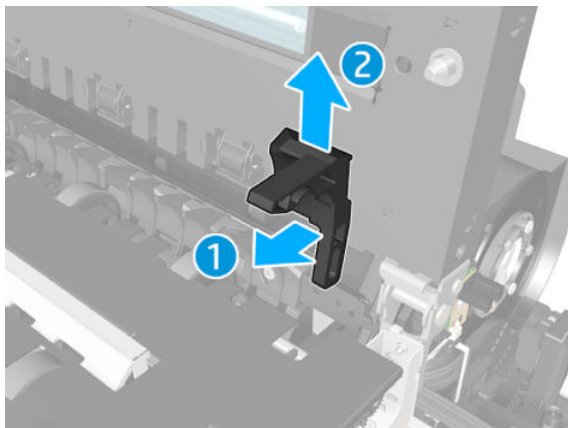

9. Rotate the Top Cover Scanner.

 **NOTE:** Do not close it.

---

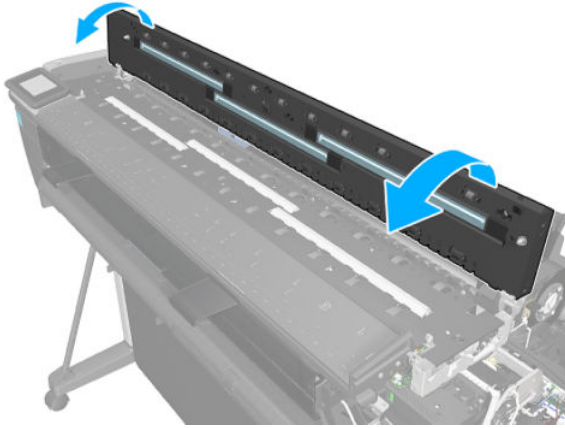

10. Unclip the Diverter from the 6 clips.

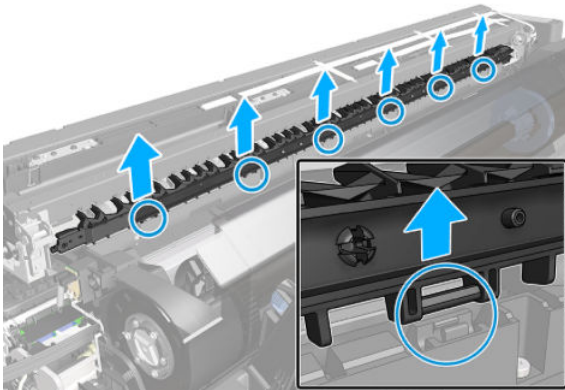

11. Remove the Diverter.

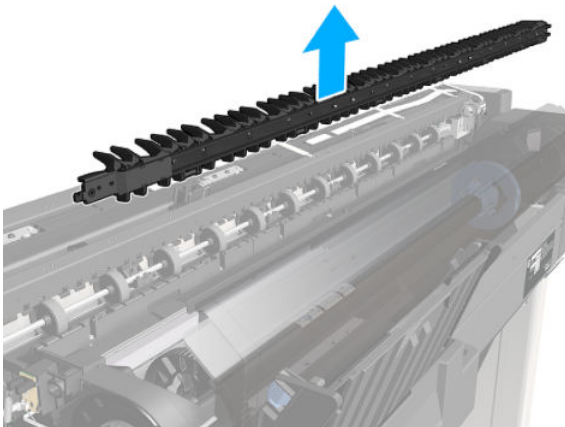

## Installation

1. In case you can't open the Top Cover Scanner use a Screwdriver.

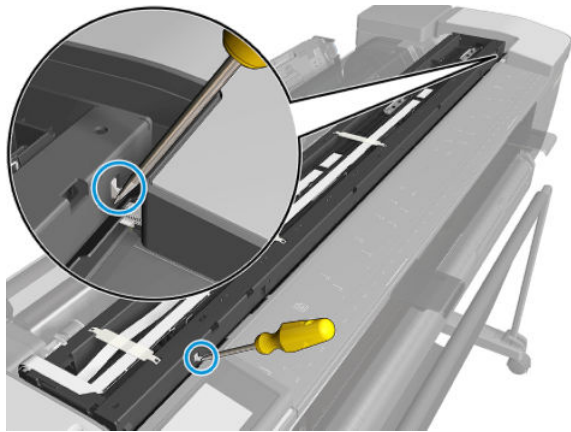

2. To install reverse the removal process.

# Diverter bottom part F9A30-67062

## Removal

**Tools:** Screwdriver Torx 10 and pliers

1. Remove the Right Cover, see [Right Cover MFP SV Kit F9A30-67011 on page 264](#).
2. Remove the Rear Cover, see [Rear Cover \(MFP only\) on page 464](#).
3. Remove the Scanner Top Cover, see [Scanner Top Cover F9A30-67015 on page 423](#).
4. Remove the Diverter, see [Diverter SV F9A30-67040 on page 516](#).
5. Locate the three diverter bottom modules.

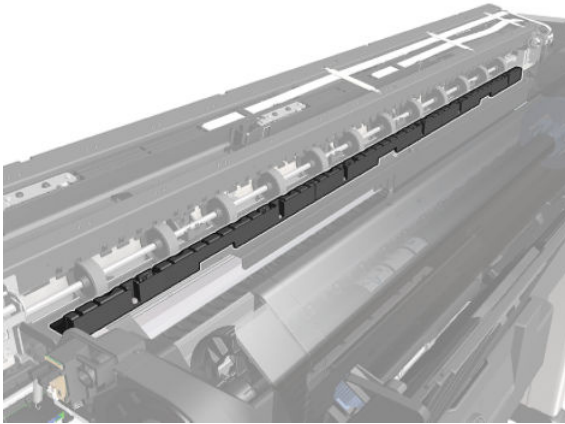

6. Remove two screws from one of the modules.

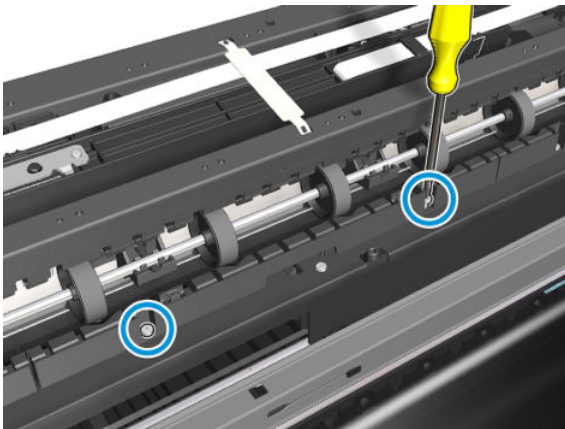

7. Remove the Diverter Bottom.

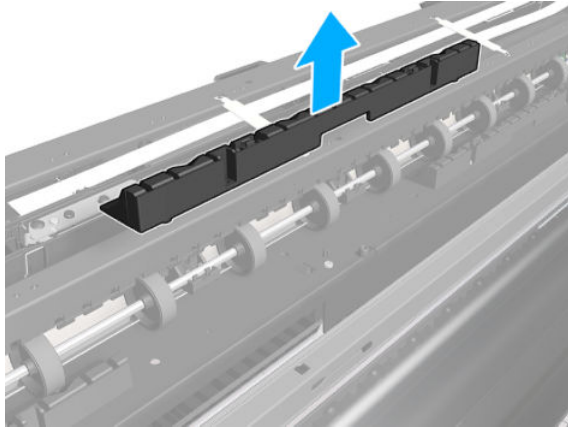

### Installation

1. In case you can't open the Top Cover Scanner use a Screwdriver.

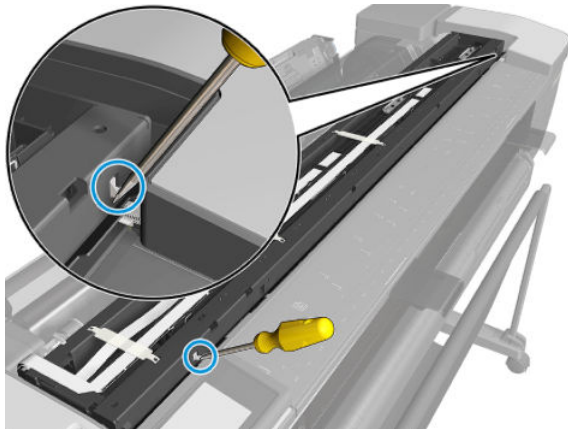

2. To install reverse the removal process.

# Latch (Right) F9A30-67030

## Removal

1. Remove the Bottom Platen, see [Bottom Platen F9A30-67042 on page 431](#).
2. Remove 1 screw.

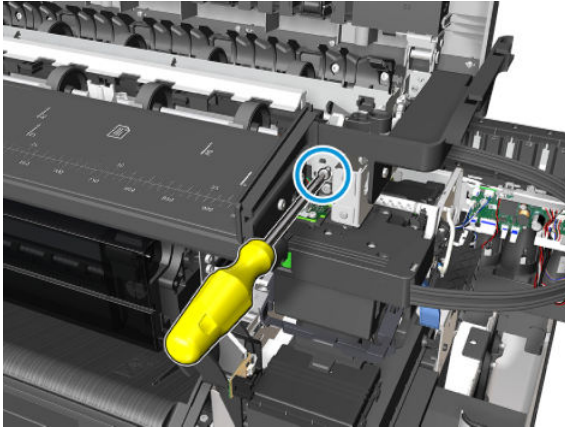

3. Unclip the Latch.

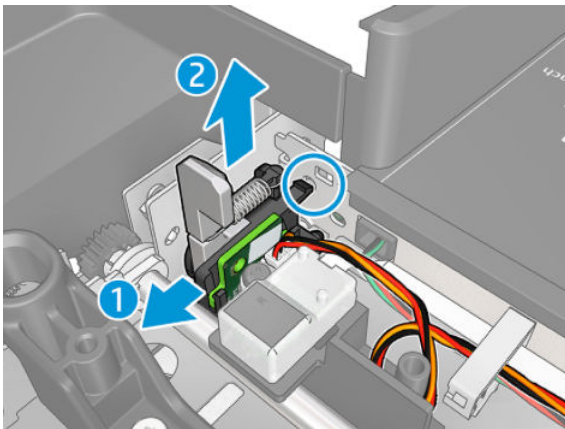

4. Disconnect the cable and remove it.

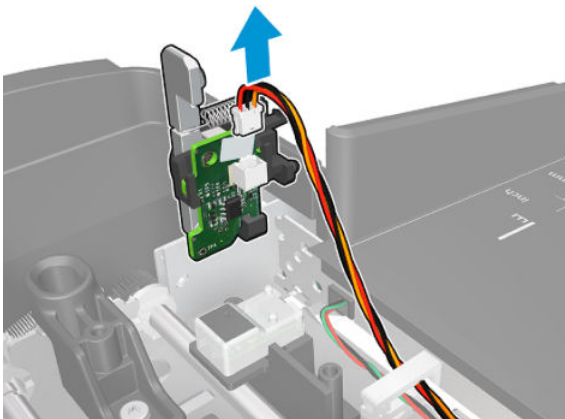

## Installation

- ▲ To install reverse the removal process.

# Latch (Left) F9A30-67030

## Removal

1. Remove the Left Cover, see [Left Cover MFP SV Kit F9A30-67012 on page 268](#).
2. Remove the Front Panel and Left Trim, see [Front Panel and Left Trim F9A30-67043 on page 526](#).
3. Remove the Bottom Platen, see [Bottom Platen F9A30-67042 on page 431](#).
4. Remove 1 screw.

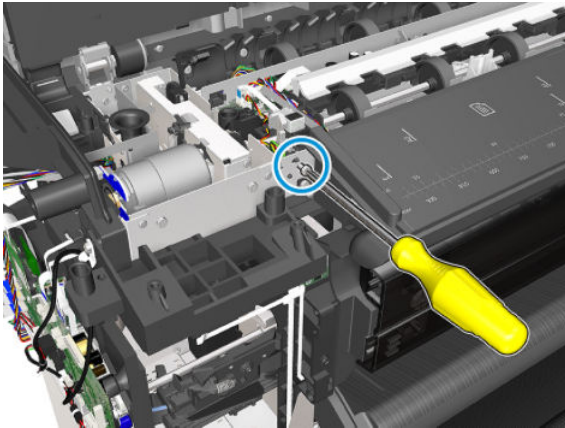

5. Unclip the Latch.

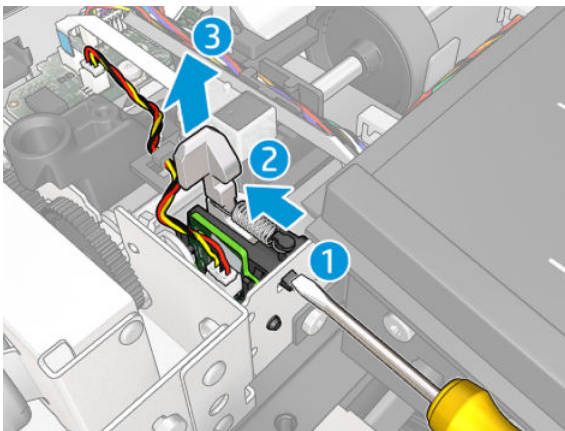



6. Disconnect the cable and remove it.

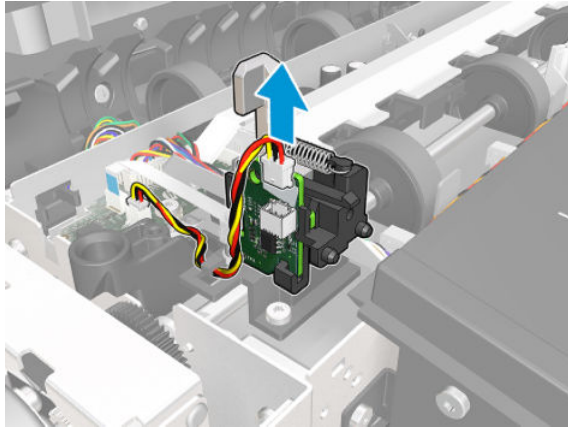

### Installation

- ▲ To install reverse the removal process.

# Front Panel and Left Trim F9A30-67043

## Removal

1. Remove the Left Cover, see [Left Cover MFP SV Kit F9A30-67012 on page 268](#).
2. Open the scanner.

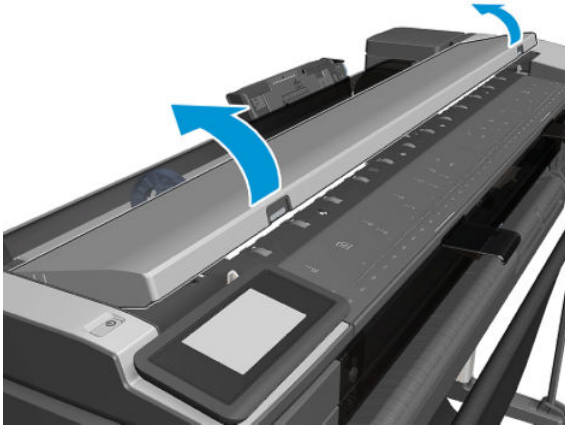

3. Disconnect the 3 cables.

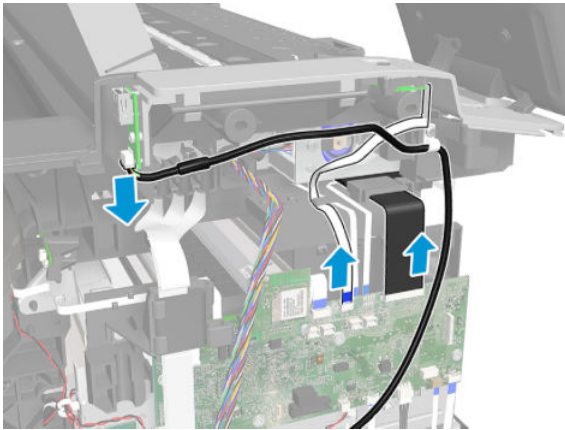

4. Remove 3 screws.

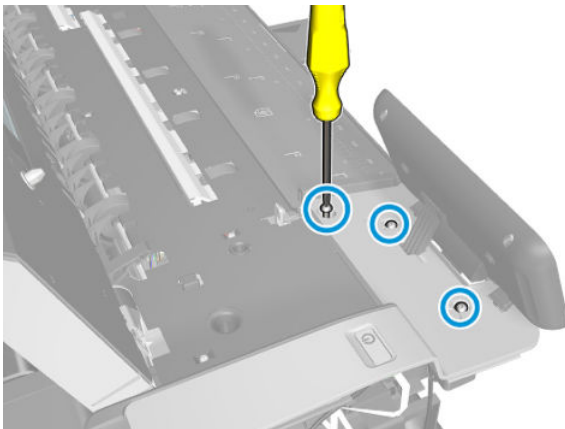

5. Unclip 4 clips.

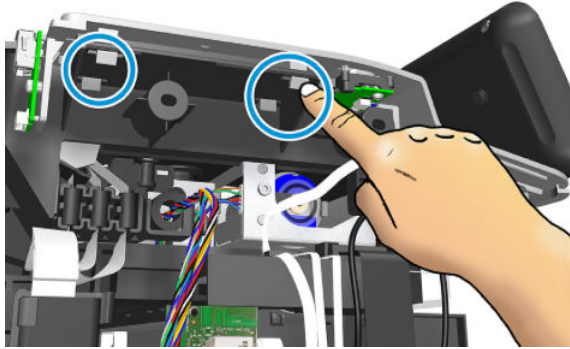

6. Unclip the ferrite and remove it.

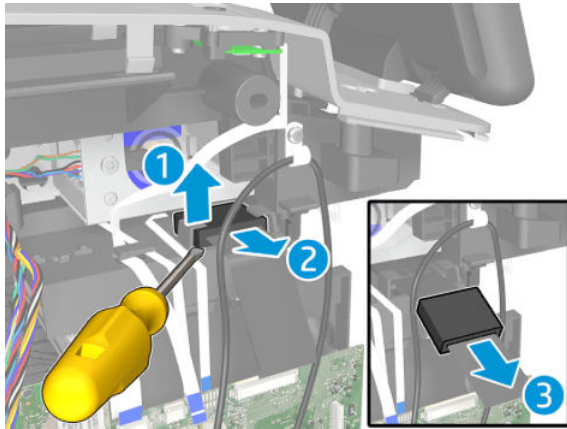

7. Carefully unroute the two cables.

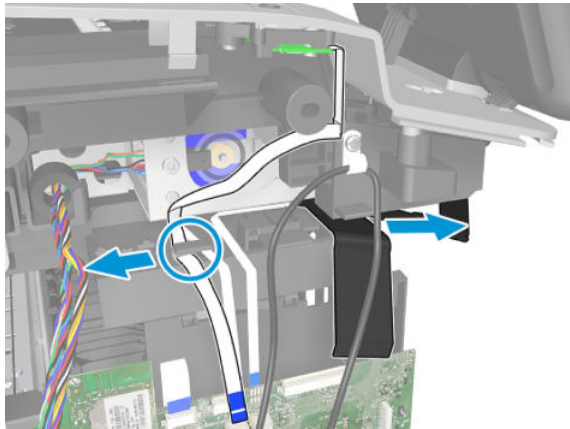

8. Remove the Front Panel and Left Trim.

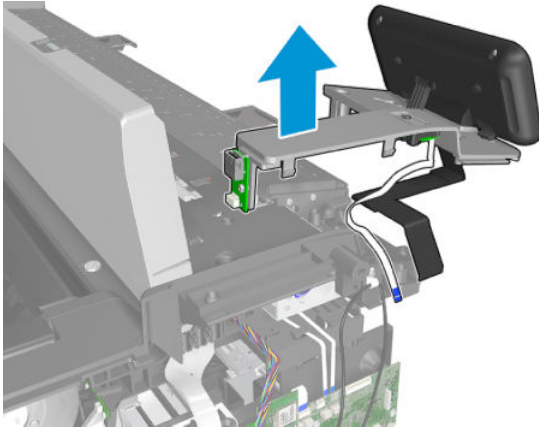

### Installation

- ▲ Install the Front Panel and Left Trim by reversing the removal process.

---

## 6 Preventive maintenance

- [Preventive maintenance](#)
- [Preventive maintenance kits](#)

# Preventive maintenance

## Clean the printer

To maintain the printer in good operating condition, keep it free of accumulated dust, ink, and other contamination. Cleaning intervals are determined by the printer environment and by the types of printer supplies used.

## General cleaning

Proper general cleaning should include the following:

---

 **NOTE:** To prevent an electric shock, make sure that the printer is switched off and unplugged before any cleaning is performed. Do **not** let any water get inside the printer.

---

1. Blow away dust accumulation with compressed air if available.
2. Clean the outer surface of the printer with a damp sponge or cloth. Use a mild soap and water solution if necessary. Do not use abrasive cleaners.
3. Wipe the printer dry with a soft lint-free cloth.

## Clean the Carriage Line Sensor

The Carriage Line Sensor should not normally require cleaning during the life of the printer. However, it may require cleaning after a bad printhead crash while printing with high ink density. In practice, it is recommended to clean the sensor if there are intermittent failures of paper edge detection, printhead alignment, or paper advance calibration.

The cleaning actually involves cleaning the clear plastic lens cover, not the sensor itself.

1. Use tap water. Do not use chemicals that could damage the clear plastic of the lens cover.
2. Use a lint-free cloth.
3. Wipe the lens with the damp cloth, then remove excess water or moisture with a dry area of the same cloth.

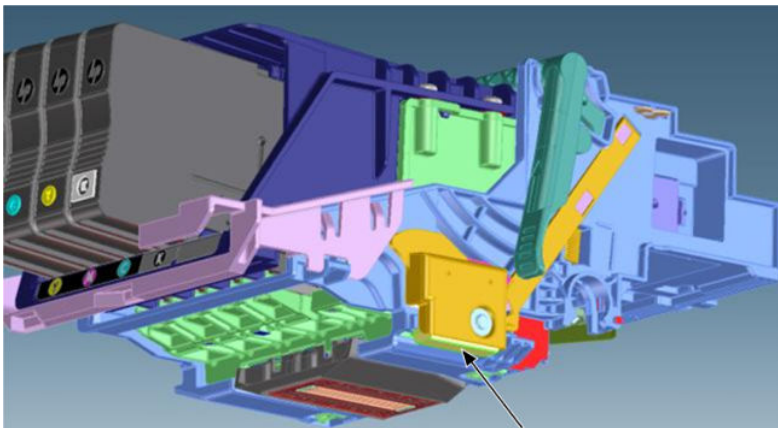

## Clean the Encoder Strip

The Encoder Strip should not normally require cleaning during the life of the printer. However, it may require cleaning in the following cases:

- When droplets of ink get into the encoder. This may happen under certain environmental conditions, with very heavy use of the printer, high ink concentrations, and system errors affecting the scan axis.
- When there is grease on the Encoder Strip. This may happen if the Encoder Strip is allowed to touch the Carriage rail during repair operations or while clearing a paper jam.

### Cleaning procedure

1. Switch off the printer and remove the power cable.
2. Move the Carriage Assembly to the capping position and uncap the printhead.



3. Place some paper over the slider rod in order to protect the lubricant and avoid cross-contamination with grease and alcohol (no specific type of alcohol is required, any cleaning alcohol can be used. A recommendation would be to use isopropyl).

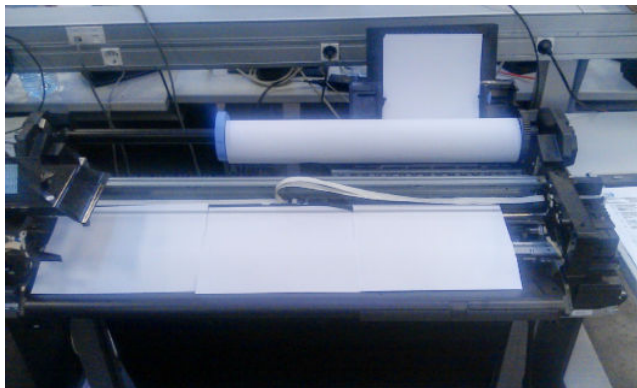

4. Dampen a cloth with alcohol.



5. Clean the encoder strip carefully, not moving the papers underneath and not stretching the strip.



6. Move the Carriage towards the center of the printer and clean the remaining portion of the strip.

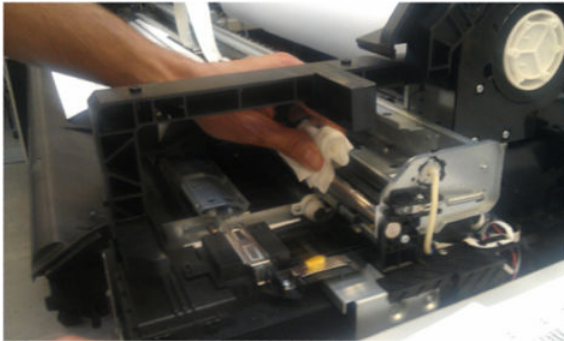

7. Return the Carriage to the capping position and cap it manually.
8. Remove the papers carefully in order not to remove grease from the slider rod.





## Lubricate the Carriage Assembly

The Carriage should not normally require lubrication during the life of the printer. However, lubrication is recommended if there are intermittent Carriage jams.

1. Lubricate the four areas indicated here.

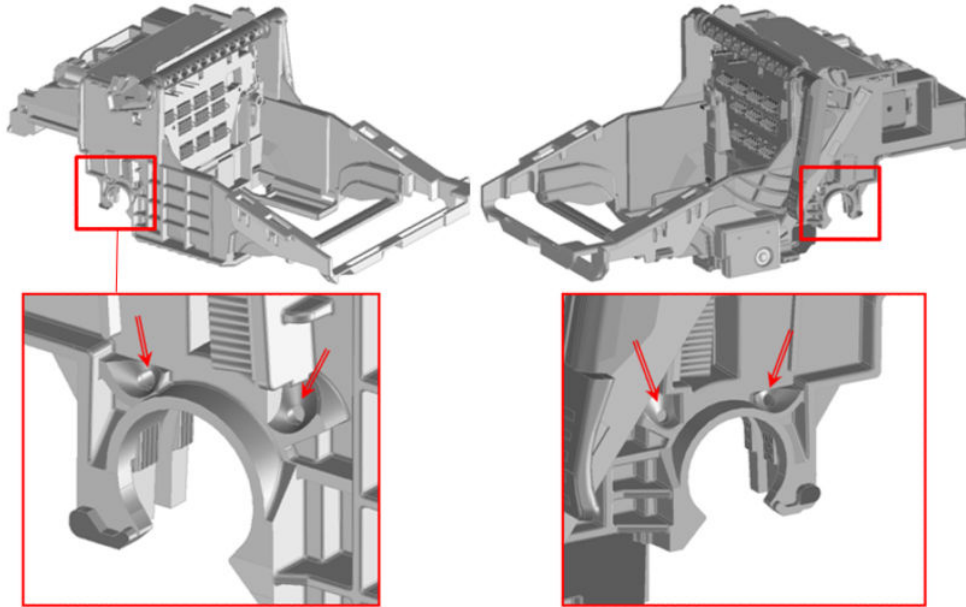

2. Lubricate the areas indicated here, A-D.

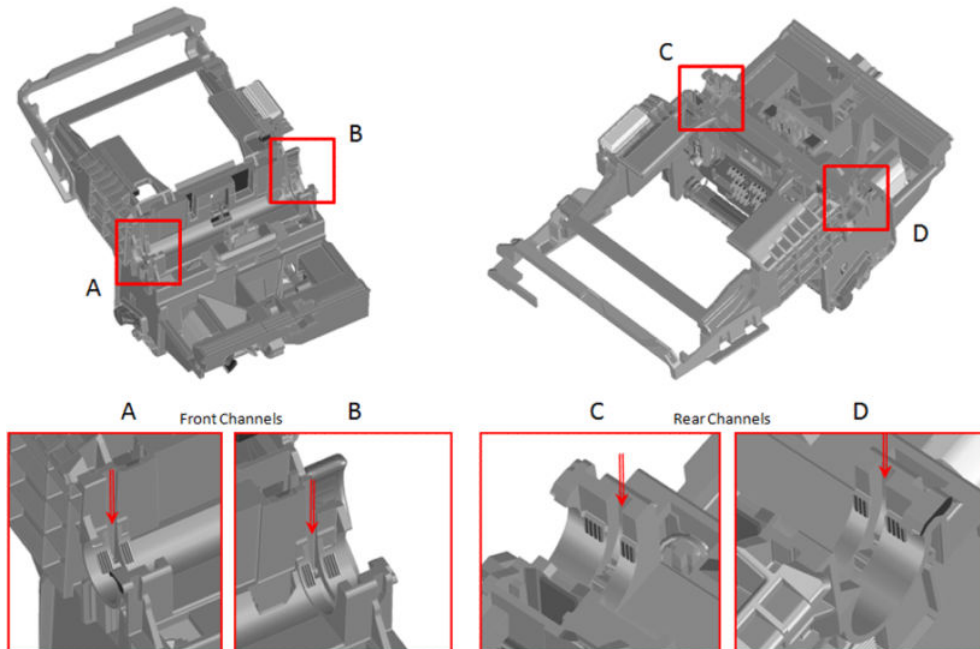

3. Use a syringe to inject grease into the ports. Push the needle against the ports firmly to direct grease into the channels.

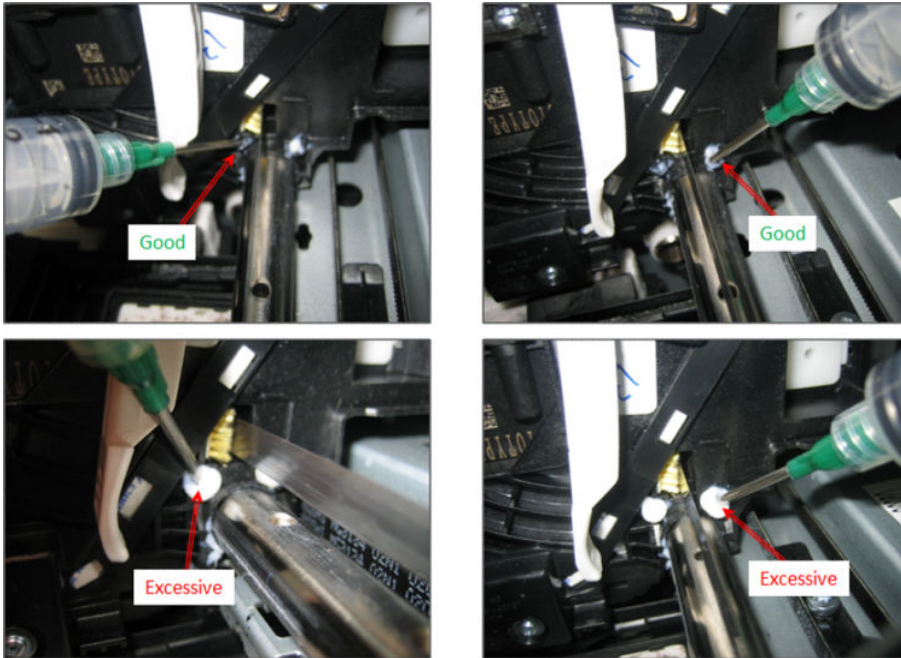

 **NOTE:** The Encoder Strip must stay free of grease. Wipe off with a dry lint-free cloth if necessary.

4. Move the Carriage 10–20 mm to check the grease on the rod.

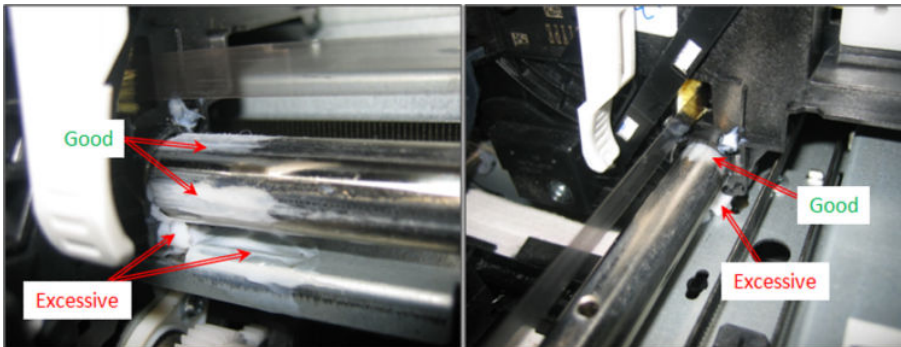

### Lubricate the Carriage Rod

1. Apply a large drop of grease to a cotton swab.



2. Apply grease to the front of the rod and smear for a distance of about 50 mm.

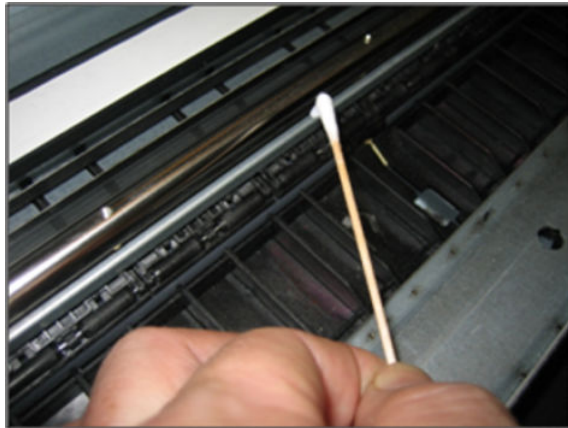

3. Apply grease to the rear of the rod and smear for a distance of about 50 mm.



## Moisture on the printer

Customers should use the printer in an environment between 20% and 80% relative humidity. To recover from moisture condensation, turn the printer off, and wait until the printer is completely dry before using it again.

## Clean the Scanner/ADF

### Clean the scanner's glass plate and white calibration sliders

You are recommended to clean the scanner's glass plate and sliders periodically, depending on how often you use the scanner.

1. Turn off the printer using the Power key at the front and disconnect the power cable.
2. Open the scanner cover.

**⚠ WARNING!** Be careful while the lid is open. If it is unexpectedly closed your fingers or hand may be trapped or crushed.

3. Gently wipe the glass plates under the lid, the white sliders, and the surrounding area with a lint-free cloth dampened with water and then wrung dry.

**⚠ CAUTION:** Do not use abrasives, acetone, benzene or fluids that contain these chemicals. Do not spray liquids directly onto the scanner glass plate or anywhere else in the scanner.

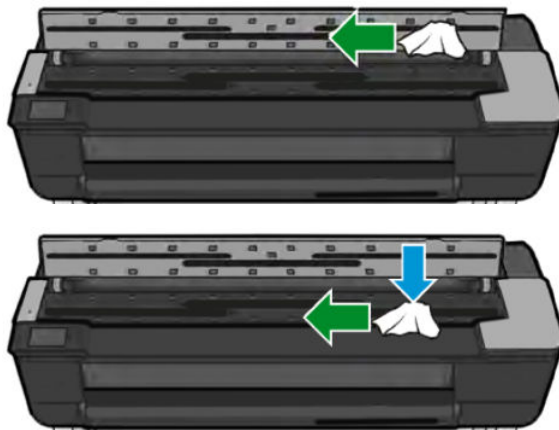

4. Optionally, for more thorough cleaning:
  - Clean the pinch rollers, the feed rollers and OPT wheel.
5. Close the scanner cover and gently push it down to lock it into place.
6. Clean the area immediately in front of the scanner, where the scanned sheet rests before scanning.
7. Reconnect the printer's power cable, turn on the power switch at the rear, and turn on the printer using the Power key.

### Level of printer usage

Normal printer use means 1.800,000m Carriage traveled distance (which corresponds approximately to more than 30,000 A1 prints on average). Under normal conditions, it will be approximately more than 5 years before the printer needs a maintenance. If the printer is used more than the normal usage conditions, then it will need maintenance service more frequently.

Service Part LIFE_VALUE Maintenance Advice	LIFE_VALUE	Maintenance Advice
Scan Axis Distance Covered	1.800,000 meters	PMKIT1

Service Part LIFE_VALUE Maintenance Advice	LIFE_VALUE	Maintenance Advice
Right Spittoon Volume	600 cc	PMKIT2
Left Spittoon Volume	51 cc	PMKIT2

When these components of the printer exceed this amount, the Front Panel displays the following message:

**"Maintenance #1 required"**

**"Maintenance #2 required"**

Once one of the maintenance advised messages is displayed, the relevant preventive maintenance kit must be used to replace the most worn parts of the printer. See [Removal and installation on page 251](#) when replacing the necessary parts.

## Preventive maintenance kits

Preventive maintenance kits are designed to replace high-usage parts before they fail, avoiding printer downtime.

### Warning message displayed on the front panel

The following is the process that the customer will see when a component has passed a maintenance usage threshold and needs replacement.

1. As the printer is turned on, if a component has passed its maximum-usage threshold a warning will be displayed. If the customer presses **OK**, the message disappears and will not reappear until the printer is turned on again.

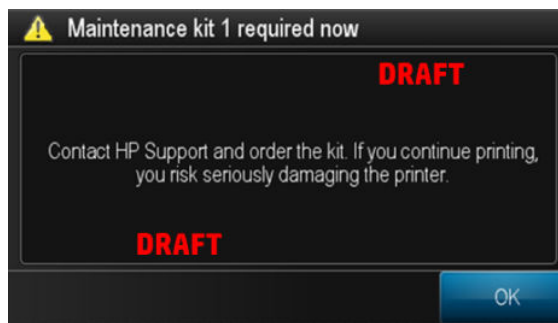

2. A warning icon will remain over the wrench until the part has been replaced. If the wrench icon is touched, before going into the setup menu, the above warning message is shown again.

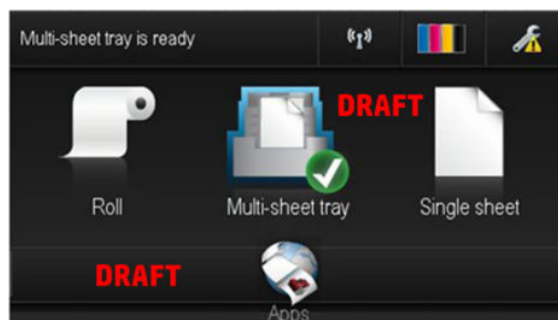

3. When the warning threshold is surpassed by a significant amount, reaching a critical threshold, the message becomes more assertive and the warnings appear more frequently.

PMK1 (Carriage)	1.800,000 meters
PMK2 (service station)	90% full of ink: 1 warning
	95% full of ink: 1 warning per print
	100% full of ink: stops printing

### Printing and interpreting the Preventive Maintenance Kit status report

The Preventive Maintenance Kit status report shows the status of the high-usage parts and how far they are from requiring replacement.

- ▲ To print the report, go to **Support Menu > Reports > PMK**.

```

#-----#
|          Preventive Maintenance Kit Status Report          |
#-----#

PMK 1: Carriage - status: Not required

* Carriage travelled distance in ~50km units
- CURRENT VALUE: 2
- Warning limit: 16
- Reset value: 0
- dsid: 76452

-----

PMK 2: Service Station - status: Not required
>>>>> CRITICAL LEVEL MESSAGE DISMISSED 3 TIMES <<<<<<<
* SVS & Left spittoon level gauge (warning at 95%, critical at 100%)
- CURRENT VALUE: 1
- Warning limit: 2
- Critical limit: 3

* SVS level gauge (%)
- CURRENT VALUE: 11

* Auxiliary spittoon level gauge (%)
- CURRENT VALUE: 2

* SVS tolerance length flag
- CURRENT VALUE: 0
- Warning limit: 1
- Reset value: 0
- dsid: 77169

```

**DRAFT**

The user has acknowledged three times the message for "critical level PMK" from the front panel. When the critical level is reached, the users must acknowledge the message every time in order to print

## Preventive Maintenance Kit #1 (Carriage)

<b>PMK #1 F9A30-67066 PM kit SV</b>	
<b>Part number</b>	<b>Description</b>
F9A30-67061	Carriage Assembly
F9A30-67063	Carriage Motor
CQ890-67091	Cutter Y margin new Extract Li

## Preventive Maintenance Kit #2 (Service Station)

<b>Part number</b>	<b>Description</b>
F9A30-67052	Service Station Assembly SV





---

# 7 Safety precautions

- [General safety guidelines](#)
- [Electrical / Fire hazard](#)
- [Mechanical hazard](#)
- [Warning labels](#)

## General safety guidelines

Before servicing the printer, read the following safety precautions to make sure that you can work on the printer safely.

- Before servicing the printer, turn it off, and disconnect electrical power. See [Safety precautions on page 541](#).
- Before removing and replacing parts, see [Removal and installation on page 251](#).

Service personnel are expected to have appropriate technical training and experience necessary to be aware of hazards to which they may be exposed in performing a task, and to take appropriate measures to minimize the risks to themselves and other people.

## Electrical / Fire hazard

- Do not set heavy objects on the power cord; do not bend the cables or force them into contorted positions.
- Do not use a damaged power cord.
- Do not handle the power cord with wet hands. Doing so may cause electric shock hazard.
- Do not allow metal or liquids (except those used in HP Cleaning Kit) to touch the internal parts of the equipment. Doing so may cause fire, electrical shock, or other serious hazards.

## Mechanical hazard

Recommended:

- Wear safety gloves when installing the assembly, taking caution not to injure yourself with edges and corners.
- Avoid wearing necklaces, bracelets and other hanging objects.
- If your hair is long, try to secure it so that it will not fall into the equipment.

## Warning labels

Label	Explanation
	<p>You are recommended to wear gloves when handling the maintenance cartridge, the platen, or the ink collector.</p> <p>This label is located on the maintenance cartridge.</p>

---

# 8 Appendices

- [Important links](#)
- [Support Menu and Extended Support Menu Tree](#)
- [How to check whether your computer is connected to your network](#)
- [Wireless troubleshooting report error cases](#)
- [Media Advance Calibration report \(Tap 11\)](#)
- [Rugged Case Accessory](#)
- [CSR fliers](#)
- [FAQ: Tips & Tricks](#)

## Important links

The following are links to useful sources of information.

- Printer drivers:
  - <http://www.hp.com/go/T730/drivers>
  - <http://www.hp.com/go/T830/drivers>
- Accessories:
  - <http://www.hp.com/go/T730/accessories>
  - <http://www.hp.com/go/T830/accessories>
- Support:
  - [www.hp.com/go/T730/support](http://www.hp.com/go/T730/support)
  - [www.hp.com/go/T830/support](http://www.hp.com/go/T830/support)

# Support Menu and Extended Support Menu Tree

Information	Resets	System configuration	Print diagnostics	Connectivity diagnostics	Reports	Scan Diagnostics
<ul style="list-style-type: none"> <li>1.1 Model number</li> <li>1.2 Serial number</li> <li>1.3 Region/Language</li> <li>1.4 Counters</li> <li>1.5 Firmware version</li> <li>1.6 Error Log</li> <li>1.7 Printer region</li> <li>1.8 Pen supply region</li> <li>1.9 Ink supply serial number (SN)</li> <li>1.10 Ink supply level of ink (LOI)</li> <li>1.11 Relocks remaining</li> <li>1.12 Relock attempts remaining</li> <li>1.13 Gather/scramble scheme</li> <li>1.14 Checksum for relock data input</li> <li>1.15 Wireless region</li> </ul>	<ul style="list-style-type: none"> <li>2.1 Country / Language reset</li> <li>2.2 Soft Reset</li> <li>2.3 Hard Reset</li> <li>2.4 Webserver password</li> <li>2.5 OOB reset</li> <li>2.6 PMK1 reset</li> <li>2.7 PMK2 reset</li> <li>2.8 Mark tubes as empty</li> <li>2.9 Line feed mfg calibration</li> <li>2.10 RTC battery expired</li> </ul>	<ul style="list-style-type: none"> <li>3.1 Set boot mode to user mode</li> <li>3.2 Set Wireless region</li> </ul>	<ul style="list-style-type: none"> <li>4.1 Nozzle health</li> <li>4.2 Bypass pen alignment</li> <li>4.3 Carriage servo</li> <li>4.4 Paper servo</li> <li>4.5 OOP Sensor</li> <li>4.6 Output tray sensor</li> <li>4.7 Line Sensor (Zin/spot)</li> <li>4.8 Display Frame Keys</li> <li>4.9 Display</li> <li>4.10 RTC battery status</li> <li>4.11 Service Station</li> <li>4.12 ISS</li> <li>4.13 Rewinder motor</li> </ul>	<ul style="list-style-type: none"> <li>5.1 Connectivity report</li> <li>5.2 Wireless diagnostic test</li> <li>5.3 Print Wireless metrics</li> </ul>	<ul style="list-style-type: none"> <li>6.1 Printer status report</li> <li>6.2 Extended self test</li> <li>6.3 Print Quality report</li> <li>6.4 Print-Mech button tap</li> <li>6.5 Counter report</li> <li>6.6 Error history</li> <li>6.7 PMK</li> <li>6.8 Agent Assisted image Test</li> </ul>	<ul style="list-style-type: none"> <li>7.1 Scanner Sensors</li> <li>7.2 Scanner Media drive</li> <li>7.3 Promote PRNU to Pristine</li> <li>7.4 Scanner <u>runout</u> calibration</li> <li>7.5 Scanner save calibrations</li> <li>7.6 Scanner Analog Encoder Calibration</li> </ul>
<ul style="list-style-type: none"> <li>• <i>Entry available in the Support Menu</i></li> <li>• <i>Entry available in the Support Menu AND in Extended Support Menu</i></li> </ul>						

# How to check whether your computer is connected to your network

1. If you are not using a unique network name (SSID), then it is possible that the computer could be connected to the wrong network. The following steps can help you to determine whether your computer is connected to the correct network.

## Windows

- a. Click **Start**, click **Control Panel**, point to **Network and Internet**, and then, in **Network and Sharing Center**, click **View Network Status and Tasks**.

Leave the network dialog box open while you continue to the next step.

- b. Disconnect the power cord from the wireless router. The connection status of the computer should change to **Not Connected**.
- c. Reconnect the power cord to the wireless router. The connection status should change to **Connected**.

## Mac OS X

- ▲ Click the **AirPort** icon in the menu bar at the top of the screen. From the menu that appears, you can determine if the AirPort is turned on and which wireless network the computer is connected to.



**NOTE:** For more detailed information about the AirPort connection, click **System Preferences** in the Dock, and then click **Network**. If the wireless connection is working correctly, a green dot appears next to AirPort in the list of connections. For more information, click the **Help** button in the window.

If you are unable to get the computer connected to your network, contact the person who set up your network or the router manufacturer as there may be a hardware issue with the router or computer.

2. Print the printer's Wireless Configuration page, see [Connectivity Diagnostics on page 201](#). After the page has been printed, check the Network Status and URL. The Network Status is Ready if the printer is actively connected to a network, or Offline if it is not (in the latter case, run the Wireless Network Test). The URL is the network address assigned to the printer by the router; you need it to connect to the printer's Embedded Web Server.
3. If you have established that the computer and the printer both have active connections to a network, you can check whether they are on the same network by trying to access the printer's Embedded Web Server. You can access the Embedded Web Server by opening a browser and typing the printer's IP address.
4. The printer may be too far away from the WiFi access point or there may be intervening objects that are preventing connection. You can try moving the printer closer to the WiFi access point.
5. Check that the WEP key password entered is the correct one. The pass phrase capitalization, punctuation, etc., must all match exactly.
6. If you cannot access the Embedded Web Server and are sure that both the computer and printer have active connections to the same network, the firewall security software could be blocking

communication. Temporarily turn off any firewall security software running on the computer, and try to access the Embedded Web Server again. If you can access it, try using the printer for printing.

If you are able to access the Embedded Web Server and use the printer with the firewall turned off, you need to reconfigure your firewall settings to allow the computer and printer to communicate with each other over the network.

If you are able to access the Embedded Web Server, but are still unable to use the printer even with the firewall turned off, try enabling the firewall software to recognize the printer.

**7.** Make sure the printer is online and ready.

If you have the HP software installed, you can check the printer's status from your computer to see if the printer is paused or offline, preventing you from using it. To check the printer's status, complete the following steps:

**Windows**

- a.** Go to **Start > Settings**, and then click **Devices and Printers**.
- b.** If the printers on the computer are not being displayed in Details view, click the **View** menu, and then click **Details**.
- c.** Do one of the following, depending on the printer status:
  - If the printer is Offline, right-click the printer, and click Use Printer Online.
  - If the printer is Paused, right-click the printer, and click Resume Printing.
- d.** Try using the printer over the network.

**Mac OS X**

- a.** Click System Preferences in the Dock, and then click Print & Fax.
  - b.** Select the printer, and then click Print Queue.
  - c.** If Jobs Stopped appears in the window that appears, click Start Jobs.
- 8.** If you install the HP software a second time, the installer may create a second version of the printer driver in the Printers or Printers and Faxes folder (Windows only). If you have difficulties printing or connecting to the printer, make sure the correct version of the printer driver is set as the default.
- a.** Go to **Start > Settings**, and then click **Devices and Printers**.
  - b.** Right-click the printer icon and then click **Properties, Document Defaults, or Printing Preferences**.
  - c.** On the **Ports** tab, look for a port in the list with a checkmark. The version of the printer driver that is connected wirelessly has **Standard TCP/IP Port** as the Port description, next to the checkmark.
  - d.** Right-click the printer icon for the version of the printer driver that is connected wirelessly, and select Set as Default Printer.
- 9.** Try restarting the HP Network Device Support service (Windows only).
- a.** Delete any print jobs currently in the print queue.
  - b.** On the desktop, right-click My Computer or Computer, then click Manage.

- c.** Double-click Services and Applications, then click Services.
- d.** Scroll down the list of services, right-click HP Network Devices Support, then click Restart.
- e.** After the service restarts, try using the printer over the network again.

If you still cannot use the printer over the network, or if you have periodic problems in doing so, the firewall may be interfering, or there may be a problem with the network configuration or router. Contact the person who set up the network or the router manufacturer for help.

If you are able to use the printer over the network, the network setup was successful.



# Wireless troubleshooting report error cases

In the first column of the table below, W indicates Warning and F indicates Failure.

W/F	#	Description	Internal details	Troubleshooting
W	0	Ethernet cable plugged in	The Ethernet cable is plugged in. The printing device cannot connect to a wireless network while it is connected via Ethernet. To connect wirelessly, unplug the cable from the printing device and run these tests again.	ATTENTION: Your printer is unable to connect to your wireless router.  SOLUTION 1: To connect wirelessly, disconnect the Ethernet network cable from your printer.
W	1	Ethernet cable plugged in and SSID found	A wireless network was found that matches what you have configured (%s). However, the Ethernet cable is plugged in, which will prevent you from connecting to it. To connect wirelessly, unplug the cable from the printer and run these tests again. The %s parameter will be the SSID name that is displayed on the advanced wireless networking webpage.	ATTENTION: Your printer is unable to connect to your wireless router.  SOLUTION 1: To connect wirelessly, disconnect the Ethernet network cable from your printer.
W	2	Wireless adaptor disabled	The wireless network interface in the printing device (%s) is not enabled. You cannot connect to a wireless network until this is turned on. If you want to connect to a wireless network, consult the documentation that came with the printer on how to enable the wireless interface. The first %s parameter will be the name of the interface, i.e. "Wifi0".>>	ATTENTION: The wireless radio on your printer is currently turned off.  SOLUTION 1: To connect wirelessly, disconnect the Ethernet network cable from your printer. Refer to the assembly instructions that came with your printer.
F	4	Radio hardware not functioning properly	The wireless network interface (%s) is not functioning properly. The printer cannot connect to a wireless network. This may be a problem with the printer hardware. As a first step, disconnect the power from the printer, wait a few seconds, then plug the power back in and re-run these tests. If this error message persists, the printer will need to be serviced. The %s parameter will be the name of the interface, i.e. "Wifi0".	ATTENTION: The wireless radio is not functioning. Contact HP support. The Wireless PCA needs to be repaired.

W/F	#	Description	Internal details	Troubleshooting
F	100	Possible MAC filtering	<p>The printer is configured to connect to a wireless network (%s). An access point (AP) with this SSID has been found and its settings are consistent with those configured in the printer, but you are <b>not</b> connected. Some possible causes and fixes are:</p> <p>The printer may be temporarily experiencing a problem. Turning the printer off and then back on may correct this problem.</p> <p>The AP may be temporarily experiencing a problem. Turning the AP off and then back on may correct this problem. Note that turning off the AP will cause other connected devices (computers, printers, etc.) to lose their network connection until the AP is turned back on.</p> <p>The AP firmware may be out of date. Check the manufacturer's website to see if an update is available.</p> <p>MAC address filtering may be enabled on the AP. This can prevent the printer from connecting if its MAC address is not in the AP's approved list of devices. The person who initially set up your network may have done this for added security. If this is the case you can either disable MAC filtering in the AP, or add the printing device's MAC address (%02x:%02x:%02x:%02x:%02x:%02x) to the approved list in the AP. Refer to the documentation that came with the AP for more information about MAC address filtering.</p> <p>The first %s parameter will be the SSID name that is displayed on the advanced wireless networking webpage. The second set of %s parameters will be the MAC address of the printer.</p>	<p>ATTENTION: Your printer is unable to connect to your wireless router. MAC address filtering may be enabled on your wireless router, which can prevent your printer from connecting to your wireless network during setup.</p> <p>SOLUTION 1: If MAC address filtering is enabled and you would like to keep it enabled, you must add the MAC address of your printer (available in this Test Report) to the list of permitted devices for your wireless router before continuing.</p>
F	101	Consistency check when only one AP found with matching name while trying to associate	<p>The settings you entered in the printer do not match those of the wireless network you are trying to connect to (%s). Connection was not made. Ensure that all of the wireless settings in the printer match those in the access point (AP) for this network.</p> <p>Assuming that the settings in the AP are the correct ones, change the wireless network settings in the printer. Consult the documentation that came with the printing device on how to do this. If you do need to change the settings in the AP then consult the documentation that came with the AP on how to do this. Note that this will require you to update settings in all devices (computers, printers, etc.) that connect wirelessly through this AP.</p> <p>The first %s parameter will be the SSID name that is displayed on the advanced wireless webpage.</p>	<p>ATTENTION: Your printer settings do not match your wireless router settings.</p> <p>SOLUTION 1: Run the Wireless Setup Wizard to configure your printer.</p>
W	103	AutoIP configured		

W/F	#	Description	Internal details	Troubleshooting
W	200	Check that configuration has manufacturer default SSID for access point	Your printer is configured to connect to a wireless network with a manufacturer's default SSID name (%s). You should change the name to something unique to you in order to avoid connecting to the wrong network. You will most likely experience network problems if you do not correct this problem. Even if the network appears to be functioning correctly now, it may not in the future. Refer to the documentation that came with your access point to change the SSID name. If you do change the SSID name of the wireless network, note that this will require you to update settings in all devices (computers, printers, etc.) that connect to this network. The %s parameter will be the SSID name that is displayed on the advanced wireless networking webpage.	ATTENTION: Your wireless network is currently using the manufacturer's default network name (SSID). It is recommended that you change your network name (SSID) to be unique, to avoid connecting to other wireless networks that may also be using the same default network name. If you change your network name, you will need to configure the SSID on all wireless devices to match your new network SSID.
F	201	SSID not found, infrastructure mode	<p>The SSID (%s) that you have entered in the printer does not match any of the available wireless network access points (AP). Connection was not made.</p> <p>The undirected scan list above shows all of the access points that were found nearby that are broadcasting their SSID. Your access point may not be in this list if broadcasting has been disabled. Note that if broadcasting is off it won't affect your ability to connect, just the visibility of the AP in the undirected scan list. When the SSID is correct and the AP is functioning properly, it will show up in the directed scan list above.</p> <p>Some possible causes and fixes for the connection problem are:</p> <p>You may have entered an incorrect SSID in the printing device. Refer to the documentation that came with the printer for information on how to change the SSID.</p> <p>The AP may be powered off. Make sure your AP is powered on and that the SSID is correct. Refer to the documentation that came with your AP to verify its SSID.</p> <p>The printer may be too far from your AP or there may be intervening objects that are preventing connection. You can try moving the printer and the AP closer together.</p> <p>The %s parameter will be the SSID name that is displayed on the advanced wireless networking webpage.</p>	<p>ATTENTION: Your printer is unable to connect to your wireless router.</p> <p>SOLUTION 1: Check that your wireless router is powered on.</p> <p>SOLUTION 2: Check that your printer network name (SSID) matches your wireless router network name (SSID) exactly. If they do not match exactly, run the Wireless Setup Wizard to configure your printer.</p>

W/F	#	Description	Internal details	Troubleshooting
F	202	SSID not found, ad hoc mode	<p>The printer has created an ad-hoc wireless network with SSID %s. However, no other wireless devices have been found that are using this SSID. Connection was not made. This is not a problem if the other devices you want to connect to are not powered on yet. If they are powered on then some possible causes and fixes are:</p> <p>You may have entered an incorrect SSID in the printer. In order to form an ad-hoc wireless network, all the devices must be using the same SSID. Refer to the documentation that came with the printer for information on how to change the SSID.</p> <p>The printer may be too far from any other devices in the wireless network or there may be intervening objects that are preventing connection. You can try moving the printer closer to the other devices. Note that you cannot connect to an access point (AP) using the ad-hoc method. Ad-hoc mode allows devices to communicate directly without the use of an AP. Infrastructure mode allows you to connect to a wireless network using an AP. Refer to the documentation that came with the printer if you want to connect to a wireless network with an AP.</p> <p>The %s parameter will be the SSID name that is displayed on the advanced wireless networking webpage.</p>	<p>ATTENTION: Your printer is unable to connect to your wireless router.</p> <p>SOLUTION 1: Check that your access point is powered on.</p> <p>SOLUTION 2: Check that your printer network name (SSID) matches your access point network name (SSID) exactly. If they do not match exactly, run the Wireless Setup Wizard to configure your printer.</p>
F	203	SSID found if doing case-insensitive search, ad hoc and infrastructure	<p>A wireless network was found (%s) whose name closely matches the name you have entered (%s) in the printer's wireless settings. You are not connected to this network. If this is the network you are trying to connect to, you will need to change the SSID name you have entered in the printer. Refer to the documentation that came with the printer for information on how to do this. Note that network SSID names must be entered exactly as they appear in the list above: capitalization, punctuation, etc., must all match.</p> <p>The first %s parameter will be the SSID name found during the un-directed scan, the second %s parameter will be the SSID name that is displayed on the advanced wireless networking webpage.</p>	<p>ATTENTION: Your printer is unable to connect to your wireless router. A network name (SSID) was found that closely matches your wireless network name except for upper/lower case.</p> <p>SOLUTION 1: Run the Wireless Setup Wizard to re-enter the SSID correctly.</p>

W/F	#	Description	Internal details	Troubleshooting
W	400	Signal strength when associated	<p>The signal strength of the wireless network you are connected to (%s) is %d dBm. This is below -85 dBm which may result in poor performance or an intermittent connection.</p> <p>If you are using an access point (AP), bring the printing device and AP closer together to increase the signal strength. If you are connecting to an ad-hoc wireless network, bring the printer closer to other devices in the wireless network.</p> <p>In either case there may also be intervening objects that are causing the signal strength to weaken. Large metal objects such as refrigerators, water heaters, or office furniture can block wireless signals. Try to ensure that such objects are not directly between the printer and the AP or other devices in the wireless network.</p>	<p>ATTENTION: The wireless signal strength between your printer and wireless router is weak.</p> <p>SOLUTION 1: Move your printer closer to your wireless router and avoid obstructions such as walls and large metal objects.</p> <p>SOLUTION 2: After moving your printer, run the wireless network test to verify the signal strength.</p>
W	500	Check for multiple access points (or wireless repeaters) with the target SSID	<p>There were %d access points (APs) (or wireless repeaters) with your configured SSID (%s) found in the area. The printer will connect to the one with the strongest signal.</p> <p>If you've set up a network with multiple APs, this is a normal condition. Note that the APs must be connected to the same LAN, usually via a wired connection. A special case is a wireless repeater, which is an AP but uses a wireless connection to connect to a "master" AP.</p> <p>If you have not set up a network with multiple APs, it means that someone else has a network with the same SSID nearby, in which case you could connect to the other network instead of your own. You will probably experience network problems if you do not correct this problem. Even if the network appears to be functioning correctly now, it may not in the future.</p> <p>You can solve this problem by creating a wireless network with a unique SSID. Refer to the documentation that came with your access point for information on how to change its SSID. When you change the SSID name of the wireless network, note that this will require you to update settings in all devices (computers, printers, etc.) that connect to this network.</p> <p>The %d parameter is an integer value of the number of networks found with the name, the %s parameter will be the SSID name found in the network scan.</p>	<p>ATTENTION: More than one wireless router has been found that matches your wireless network name (SSID). If this is not intended, your printer may connect to the wrong wireless network. To avoid this, change your wireless network name (SSID) to be unique. If you change your network name, you will need to configure the SSID on all wireless devices to match your new network SSID.</p>

W/F	#	Description	Internal details	Troubleshooting
F	600	Incorrect WEP key	<p>The printer is connected to a wireless network (%s) that requires a WEP key. The key you have provided does not match what is expected. Although it looks as if a valid connection is made, the printer will not receive any data. You will need to enter a matching WEP key in the printer. Refer to the documentation that came with the printer for information on how to change the WEP key.</p> <p>The person who initially set up your network should be able to provide you with the correct WEP key to use. Alternately, if you are connecting to an access point (AP), you may be able to find the matching WEP key from the AP. Consult the documentation that came with the AP on how to do this.</p> <p>The %s parameter will be the SSID name found in the network scan.</p>	<p>ATTENTION: The WEP security key configured on your printer does not match your wireless router setting. The WEP key index setting on your printer has been changed from the default setting of "1". This may cause problems when connecting to your wireless network if your wireless router is not using the same WEP key index value.</p> <p>SOLUTION 1: Run the Wireless Setup Wizard to re-enter your wireless network WEP security key.</p>
I	601	Unknown WEP decrypt status	<p>The printer is connected to a wireless network (%s) that requires a WEP key. However, no data have been sent to the printer. Because of this, it is unknown whether the WEP key entered in the printer matches that of the wireless network.</p> <p>Usually this is a temporary condition. Once some data are sent, the printer will be able to determine whether the WEP keys match. Try running this report again in a few seconds.</p> <p>The %s parameter will be the SSID name found in the network scan.</p>	
W	602	WEP key index is different from 1	<p>The printer is connected to a wireless network (%s) that requires a WEP key. Data are not being received. You are using a WEP key index of %d. A WEP key index of 1 is typical.</p> <p>If the index does not match what the wireless network is expecting, it will prevent the printer from being able to receive data. The person who initially set up your network should be able to provide you with the correct WEP key index to use. Alternately, if you are connecting to an access point (AP), you may be able to find the matching WEP key index from the AP. Consult the documentation that came with the AP on how to do this.</p> <p>If you do need to change the WEP key index of the printer, refer to the documentation that came with the printer for information on how to do this.</p> <p>The %d parameter will be the index, the %s parameter will be the SSID name found in the network scan.</p>	<p>ATTENTION: The WEP key index setting on your printer has been changed from the default setting of "1". This may cause problems when connecting to your wireless network if your wireless router is not using the same WEP key index value.</p> <p>SOLUTION 1: Run the Wireless Setup Wizard to re-enter your wireless network WEP security key.</p>

W/F	#	Description	Internal details	Troubleshooting
F	604	Non-default WEP Authentication	<p>The printer is configured to connect to a WEP wireless network (%s), and the printer's configured authentication method ("%"s") has been changed from its default setting ("Automatic (Open then Shared)").</p> <p>This could potentially cause the printer to be unable to connect to the wireless network. The printer's default setting should always work and avoids any potential future problems. Unless you know that the printer's current setting is correct for your wireless network, it is recommended that this setting be changed back to the default. Refer to the documentation that came with the printer for information on how to configure the WEP authentication method.</p> <p>The first %s parameter will be the SSID name found in the network scan , the second %s parameter will be the actual value of the setting.</p>	<p><b>ATTENTION:</b> The WEP key authentication setting on your printer has been configured to a non-default setting. This may cause problems when connecting to your wireless network if your wireless router is not using the same WEP authentication method.</p> <p><b>SOLUTION 1:</b> Refer to your printer documentation for information on configuring WEP.</p>
F	605	Non-default WPA Encryption	<p>The printer is configured to connect to a WPA-PSK wireless network, (%s) and the printer's configured encryption method ("%"s") has been changed from its default setting ("Automatic (AES or TKIP)").</p> <p>This could potentially cause the printer to be unable to connect to the wireless network. The printer's default setting should always work and avoids any potential future problems. Unless you know that the printer's current setting is correct for your wireless network, it is recommended that this setting be changed back to the default. Refer to the documentation that came with the printer for information on how to configure the WPA-PSK encryption method.</p> <p>The first %s parameter will be the SSID name found in the network scan , the second %s parameter will be the actual value of the setting.</p>	<p><b>ATTENTION:</b> The WPA encryption method on your printer has been configured to a non-default setting. This may cause problems when connecting to your wireless network if your wireless router is not using the same WPA encryption method.</p> <p><b>SOLUTION 1:</b> Refer to your printer documentation for information on configuring WPA.</p>

<b>W/F</b>	<b>#</b>	<b>Description</b>	<b>Internal details</b>	<b>Troubleshooting</b>
F	606	Non-default WPA Authentication	<p>The printer is configured to connect to a WPA-PSK wireless network, (%s) and the printer's configured WPA version (\ "%s\ ") has been changed from its default setting (\ "Automatic (WPA2 or WPA1)\ ").</p> <p>This could potentially cause the printer to be unable to connect to the wireless network. The printer's default setting should always work and avoids any potential future problems. Unless you know that the printer's current setting is correct for your wireless network, it is recommended that this setting be changed back to the default. Refer to the documentation that came with the printer for information on how to configure the WPA-PSK WPA version.</p> <p>The first %s parameter will be the SSID name found in the network scan , the second %s parameter will be the actual value of the setting.</p>	<p><b>ATTENTION:</b> The WPA authentication method on your printer has been configured to a non-default setting. This may cause problems when connecting to your wireless network, if your wireless router is not using the same WPA authentication method.</p> <p><b>SOLUTION 1:</b> Refer to your printer documentation for information on configuring WPA.</p>
F	609	Non-standard WPA mode		<p><b>ATTENTION:</b> Your printer is unable to connect to your wireless router. This may be caused by the following settings on your wireless router: 1) 802.11n devices only and 2) WPA-TKIP only encryption. WPA-TKIP is no longer allowed for newer certified wireless 802.11n devices because WPA-AES provides stronger security.</p> <p><b>SOLUTION 1:</b> Change your wireless router encryption setting to "WPA-AES" or "WPA-AES or TKIP" (also called "mixmode"), then run the printer's Wireless Setup Wizard again.</p>



## Media Advance Calibration report (Tap 11)

Media Advance calibration and Scanner calibrations can be see on the Tap Report: **Support Menu > Reports > 6.4 Print-Mech button tap**. Type code 11.

Serial Number: CN58V0M05R  
FW Revision: CANDELPR2N002.1545A.00  
Total Engine Page Count: 36

Encoder Calibration Data

SERVO\_PAPER (Enc Index: 0)

Ch:	A	B
A Gain:	0	0
D Gain:	0	0
D Offset:	-1	-4
Init min:	17	23
Init max:	242	241
X H min:	200	200
X H max:	212	212
X L min:	39	39
X L max:	50	50
X %:	80	80

SERVO\_OPT\_ENC (Enc Index: 1)

Ch:	A	B
A Gain:	0	83
D Gain:	0	73
D Offset:	68	68
Init min:	0	0
Init max:	0	0
X H min:	0	0
X H max:	0	0
X L min:	0	0
X L max:	0	0
X %:	0	0

Decel Offset Tables

SERVO\_PAPER DO

0 - 9:	0	0	0	0	-4	-200	-58	-68	0	0
10 - 19:	0	0	0	0	0	0	0	0	0	0
20 - 29:	0	0	0	0	0	0	0	0	0	0

SERVO\_PAPER DOA

0 - 9:	0	0	0	0	-176	-89	-195	-212	0	0
10 - 19:	0	0	0	0	0	0	0	0	0	0
20 - 29:	0	0	0	0	0	0	0	0	0	0

LFA Data

Roll Offset	-18	Tray Pre Offset	-11
Amplitude	1	Tray Post Offset	20
Phase	317	Tray Status	359

Cal Linefeed Page Error

1: 0	2: 0	3: 0	4: 0	5: 0	6: 0	7: 0	8: 0	9: 0	10: 0
11: 0	12: 0	14: 0	15: 0	16: 0	17: 0	20: 0	21: 0	22: 0	

Manual Offset Values

1: 0	2: 0	3: 0	4: 0	5: 0	6: 0	7: 0	8: 0	9: 0	10: 0
11: 0	12: 0	14: 0	15: 0	16: 0	17: 0	20: 0	21: 0	22: 0	

SCANNER CALIBRATIONS

LFS Data

OPT wheel offset	:	64000
OPT wheel slope	:	-33
OPT wheel sin amplitude:		-81853
OPT wheel cos amplitude:		717519

CIS module alignment data

Interface #1:	x[ 291]	y[ 603]
Interface #2:	x[ 292]	y[ 599]

## Factory Calibration Values

LFA Data			
Roll Offset	-18	Tray Pre Offset	-11
Amplitude	1	Tray Post Offset	20
Phase	317	Tray Status	359

Cal Linefeed Page Error									
1: 0	2: 0	3: 0	4: 0	5: 0	6: 0	7: 0	8: 0	9: 0	10: 0
11: 0	12: 0	14: 0	15: 0	16: 0	17: 0	20: 0	21: 0	22: 0	

Manual Offset Values									
1: 0	2: 0	3: 0	4: 0	5: 0	6: 0	7: 0	8: 0	9: 0	10: 0
11: 0	12: 0	14: 0	15: 0	16: 0	17: 0	20: 0	21: 0	22: 0	

## Customer Manual Calibration Values

### SCANNER CALIBRATIONS

#### LFS Data

```
OPT wheel offset      : 64000
OPT wheel slope      : -33
OPT wheel sin amplitude: -81853
OPT wheel cos amplitude: 717519
```

#### CIS module alignment data

```
Interface #1: x[ 291] y[ 603]
Interface #2: x[ 292] y[ 599]
```

*HP HW Coated roll is slot #3*

*Plain cut sheet is slot #16*

Typical calibration values should range from -20 to +20 in user and manual advance calibration.

Media	Table #	Media Path
HP Bright White Inkjet	0	Roll
HP Univ. Bond	1	Roll
HP Coated	2	Roll
HP HW Coated	3	Roll
Diamond NTP (73 gsm)	4	Roll
HP Vellum	5	Roll
HP Universal Gloss Photo	6	Roll
HP Premium Gloss Photo	7	Roll
HP Universal Instant-dry Photo	12	Roll
Artisan PolyBanner Satin Polypropylene	8	Roll
HP Matte Film	9	Roll
HP Adhe. Vinyl	10	Roll
HP Self-adhesive Gloss Polypropylene	11	Roll
Any (unknown)	13	Roll
Any (unknown)	14	Roll
HP MP (11"x17")	16	Multi-Sheet Tray
HP Premium Presentation (11"x17")	19	Multi-Sheet Tray

<b>Media</b>	<b>Table #</b>	<b>Media Path</b>
HP Adv. Photo (13"x19")	21	Multi-Sheet Tray
HP Prem. Plus Photo (13"x19")	20	Multi-Sheet Tray

# Rugged Case Accessory

## Overview

The rugged case accessory delivers robust protection for tough environments, making the unit mobile even in the worst terrains, and providing ease of transportation.

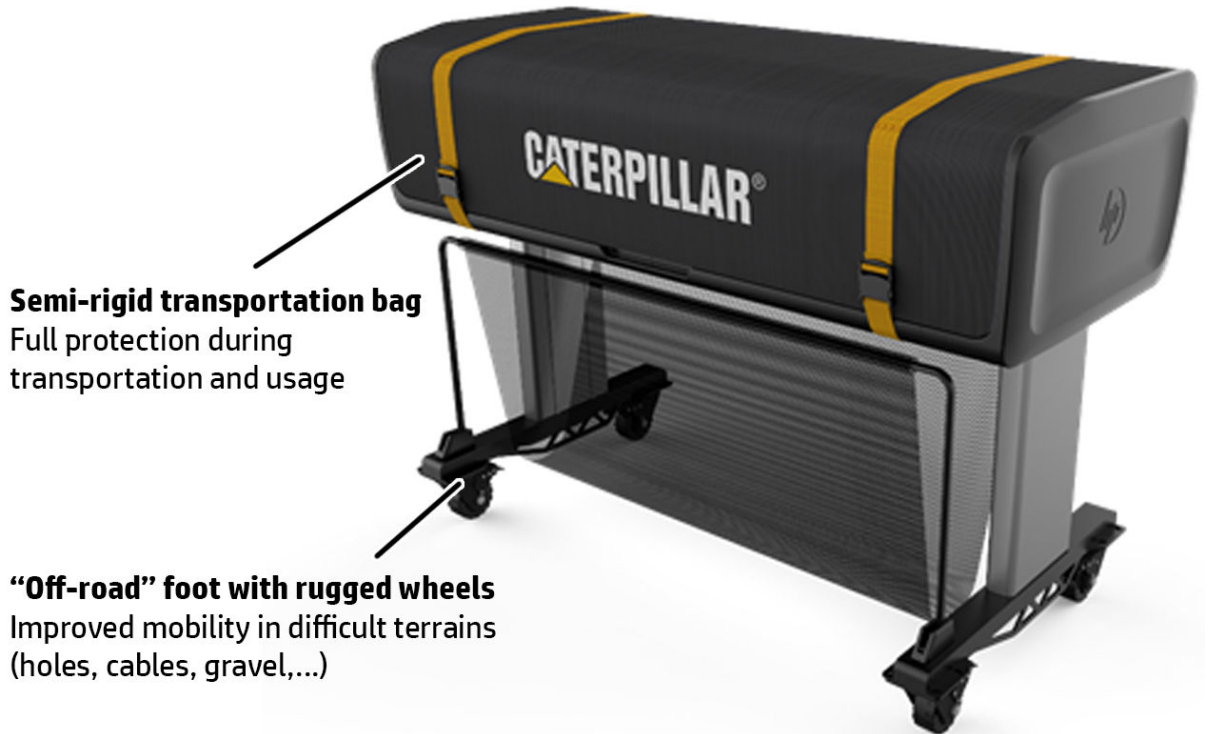

**Semi-rigid transportation bag**  
Full protection during transportation and usage

**“Off-road” foot with rugged wheels**  
Improved mobility in difficult terrains (holes, cables, gravel,...)

The rugged case accessory is a CSR accessory that includes its own Set Up poster. It reuses the following standard stand components:

- Right leg
- Left leg
- Basket
- Beam

## Operating conditions

Storage/overnight configuration:



Two operating configurations:

- Lid fully open:



- Lid partially open:



## Support impact

### Operations permitted

The rugged case allows all access to media jam removal, multi sheet tray detachment, roll load, etc..

## Operations not permitted

### Service actions implying removal of covers:

**Solution:** Remove the printer from the rugged case;

1. Remove rugged case right side (2 T25 + 2 T30 screws).
2. Remove rugged case left side (2 T25 + 2 T30 screws).
3. Unscrew the 4 knobs that attach the unit to the stand (the rugged case is sandwiched between the stand and printer).
4. Remove the unit from the stand and rugged case base.
5. Remove the covers.

### PHA replacement:

**Solution:** Remove the rugged case right side component (2 T25 + 2 T30 screws).

## Extra accessory pictures







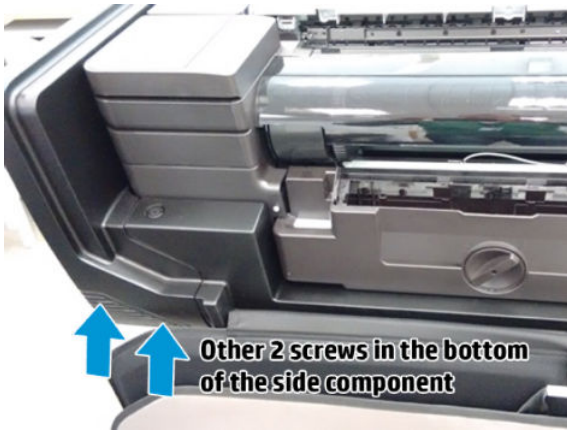
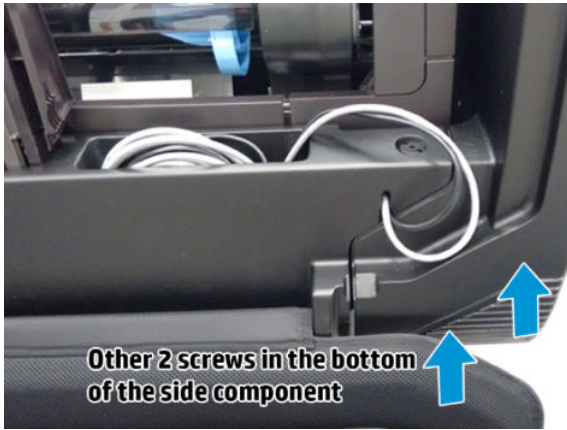



## CSR fliers

- [Accessory Tray flier](#)
- [Front Cover flier](#)
- [Multi-Sheet Tray Extension flier](#)
- [Out-Of-Paper Sensor flier](#)
- [Output Tray flier](#)
- [Output Tray Sensor flier](#)
- [Printhead Replacement Kit flier](#)
- [Scanbar replacement flier](#)
- [Calibration Surface flier](#)
- [Ink Door flier](#)
- [Refeed Preventer flier](#)
- [Pressure Rollers flier](#)
- [Cutter flier](#)
- [Stand Left Leg flier](#)
- [Stand Right Leg flier](#)
- [Stand Basket flier](#)
- [Printhead Door flier](#)

## Accessory Tray flier

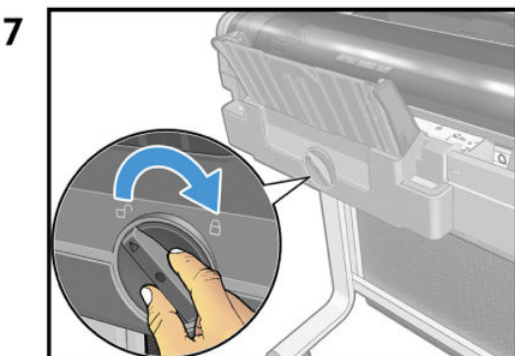
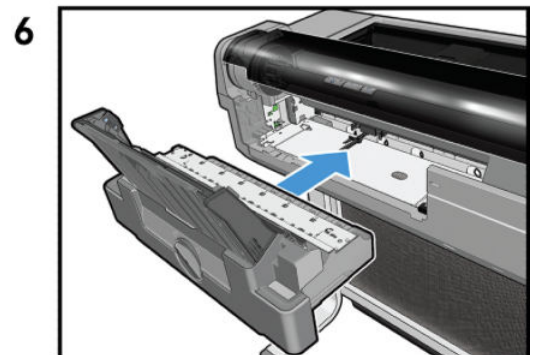
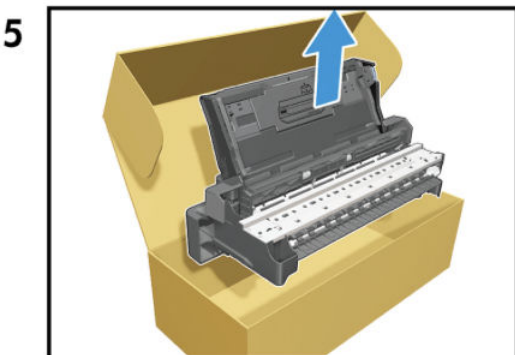
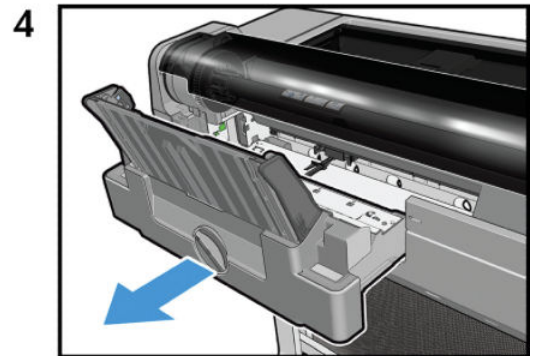
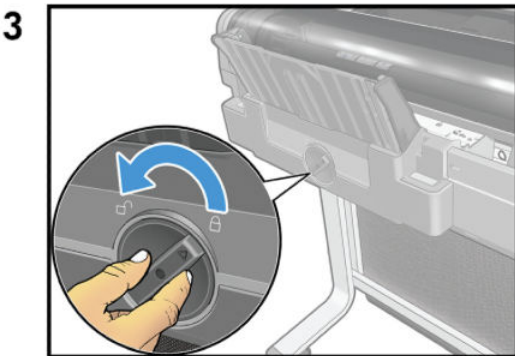
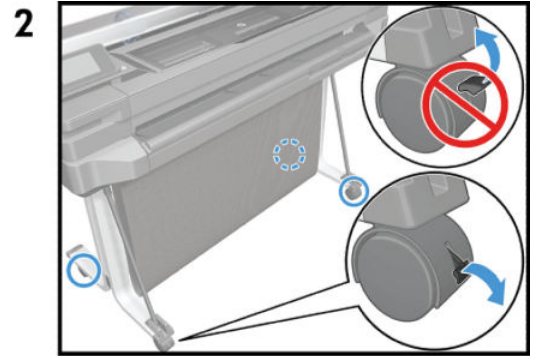

## Front Cover flier

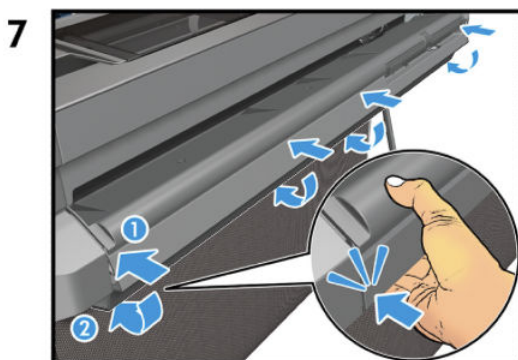
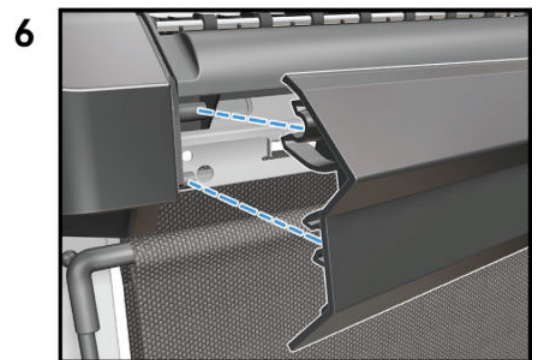
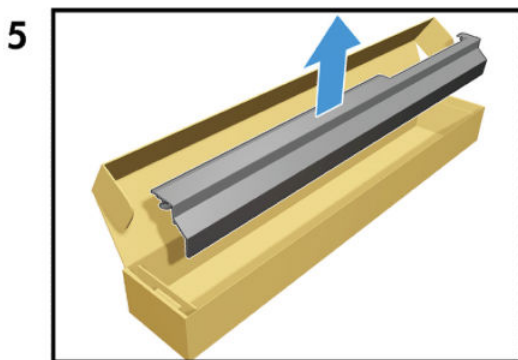
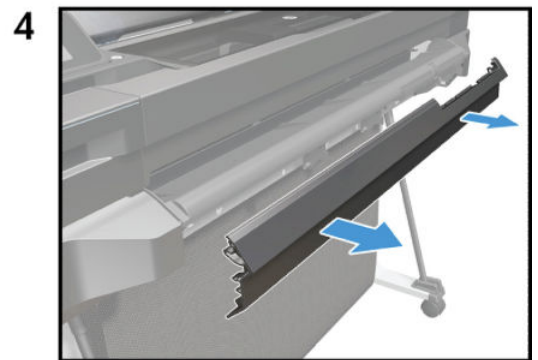
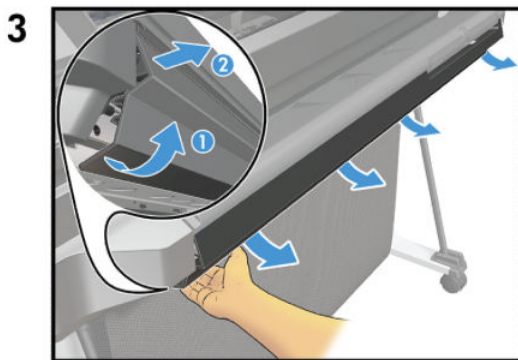
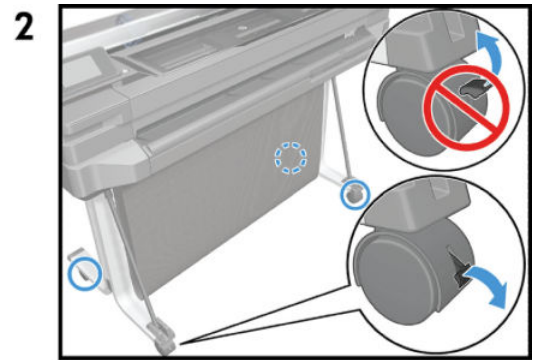

## Multi-Sheet Tray Extension flier

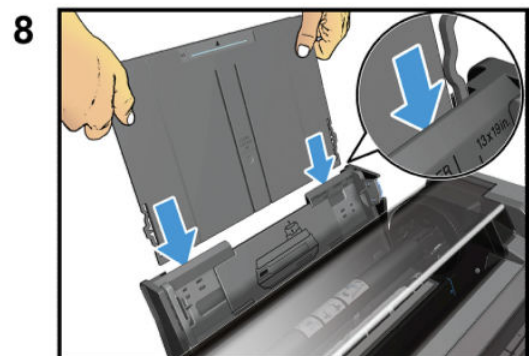
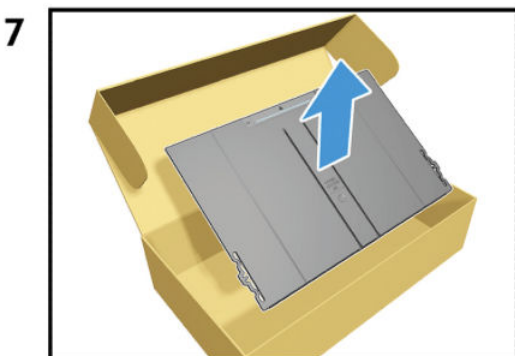
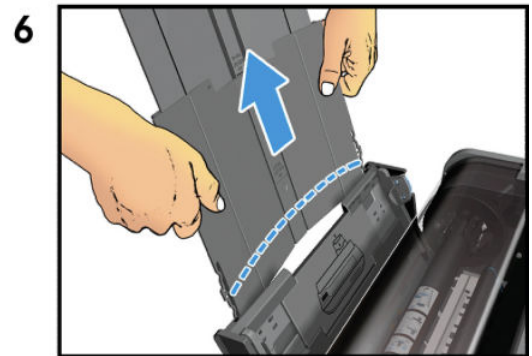
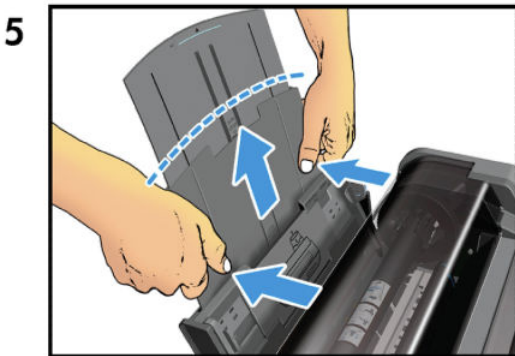
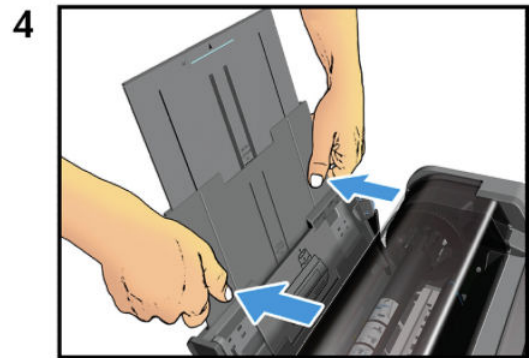
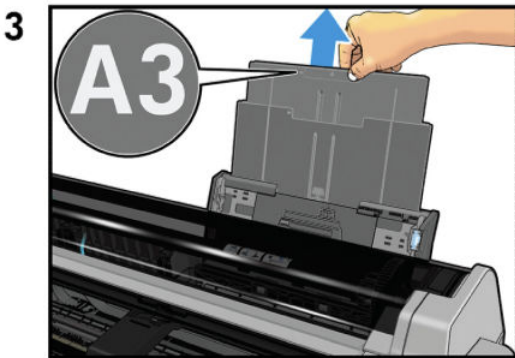
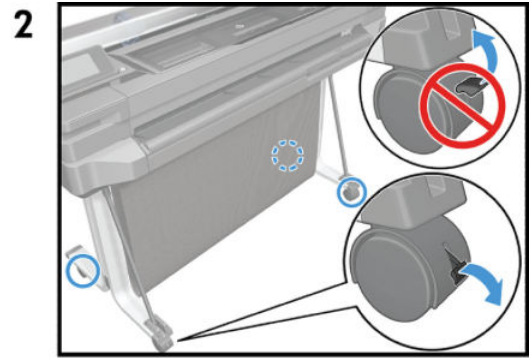

9



## Out-Of-Paper Sensor flier

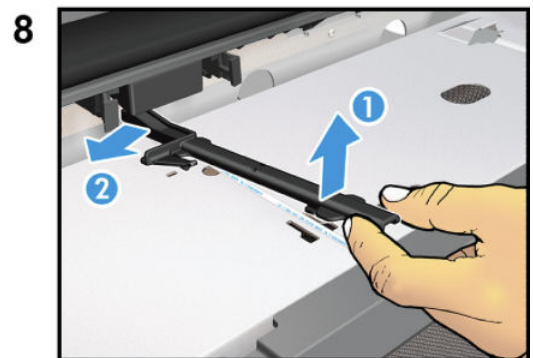
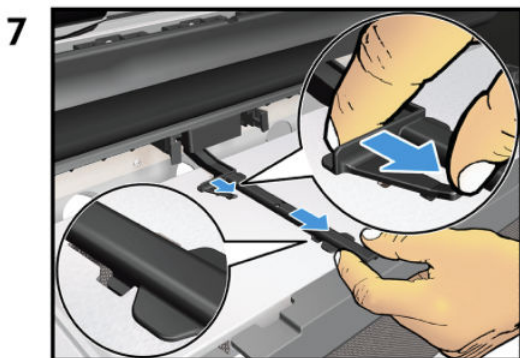
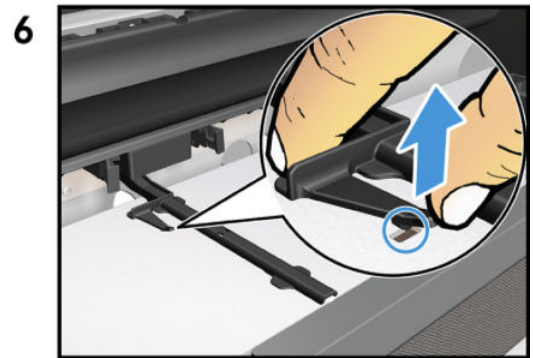
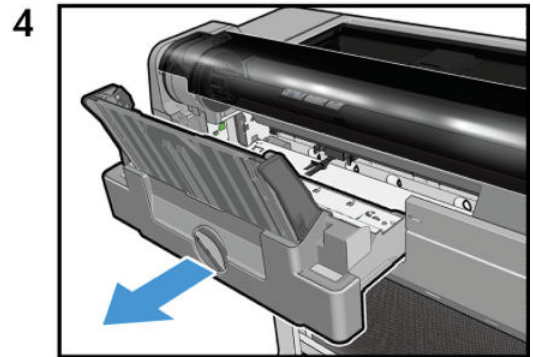
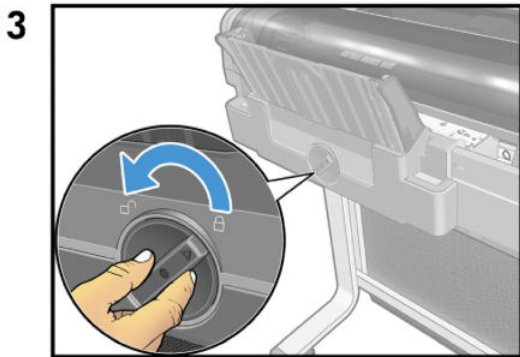
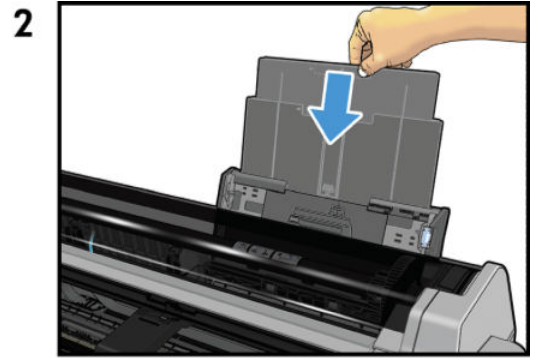



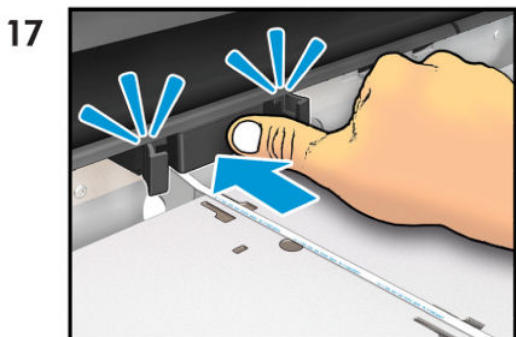
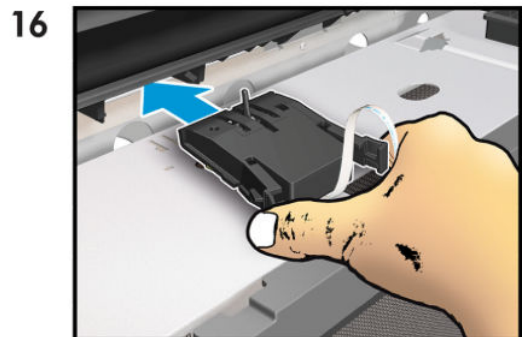
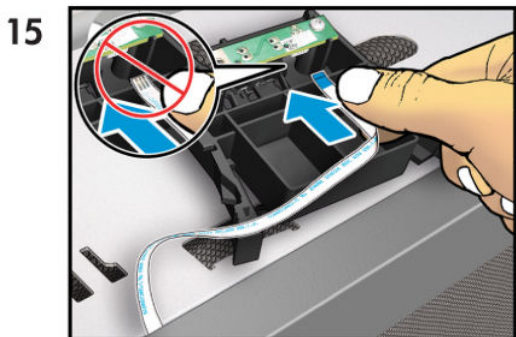
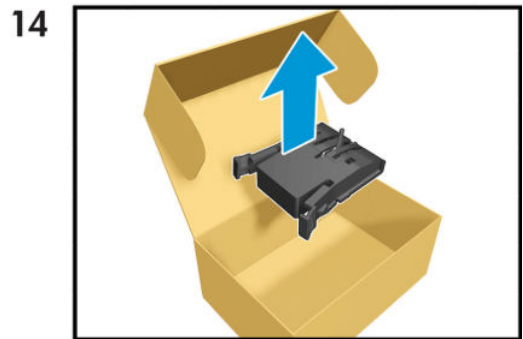
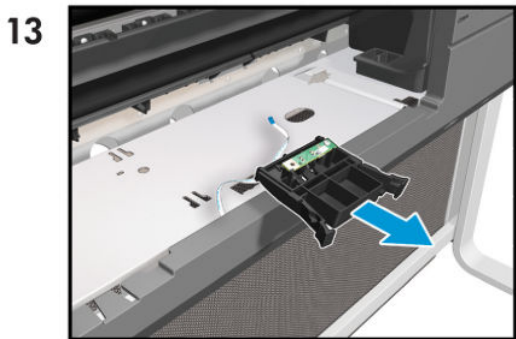
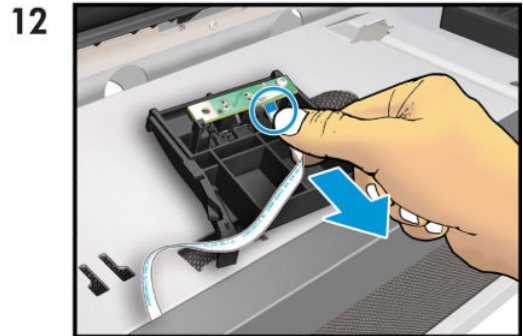
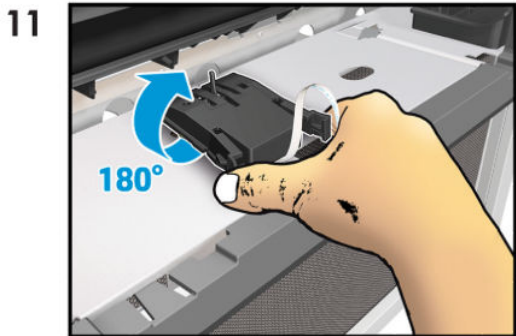
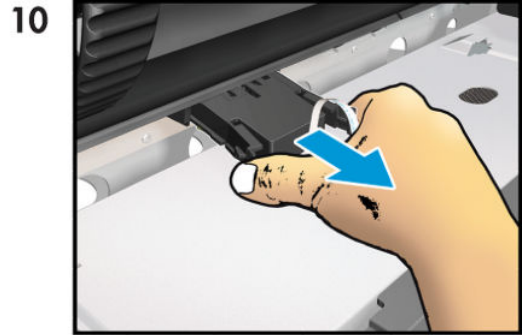
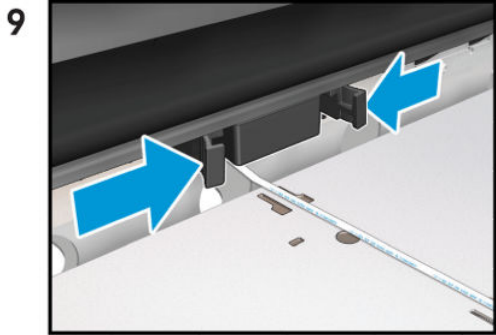

19

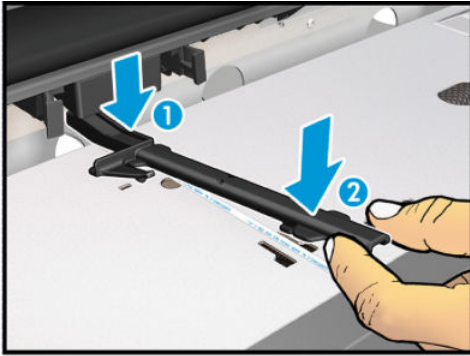

20

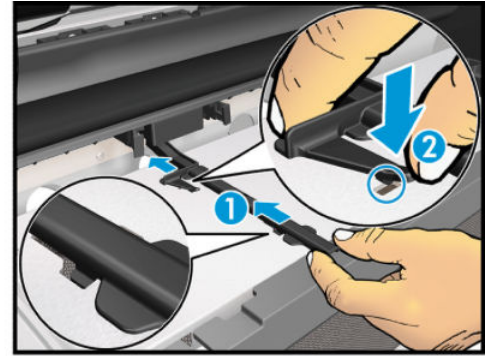

21

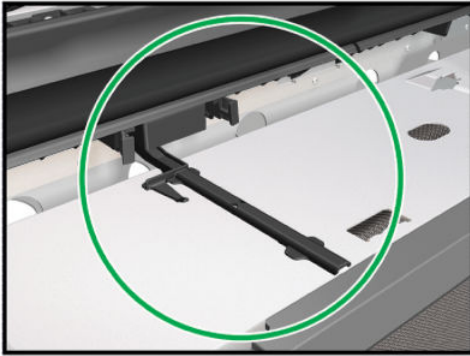

22

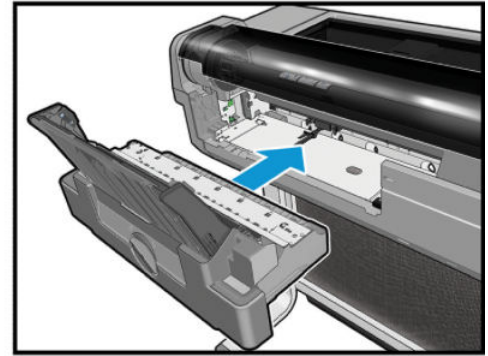

23

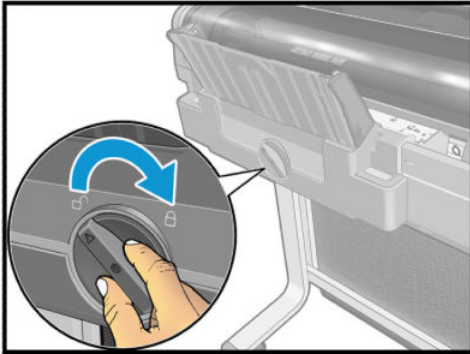

## Output Tray flier

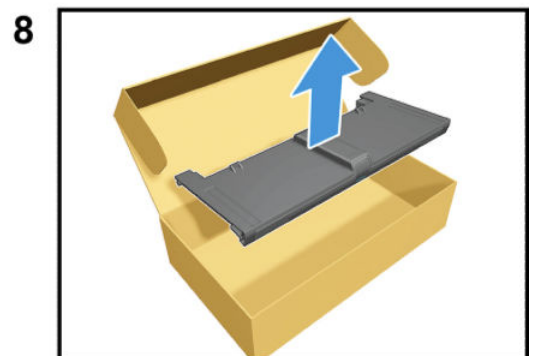
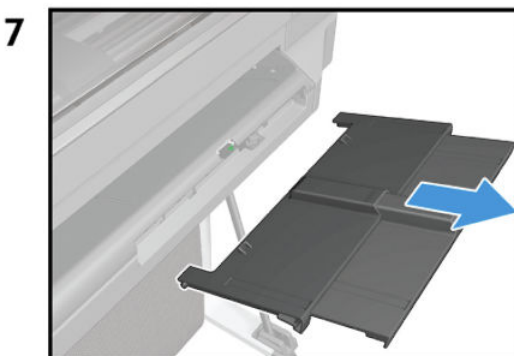
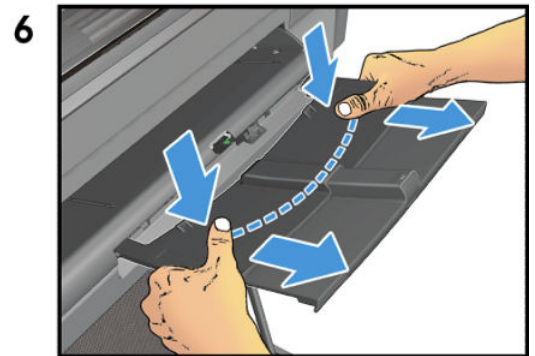
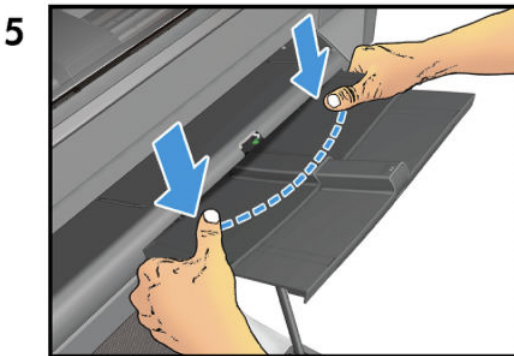
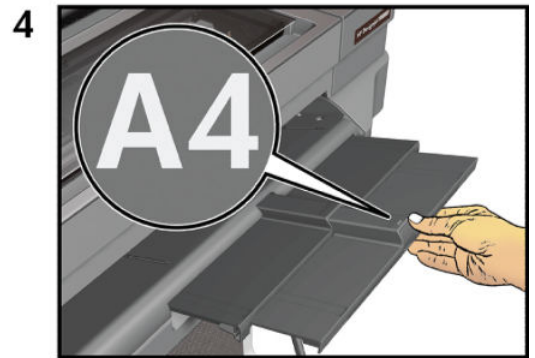
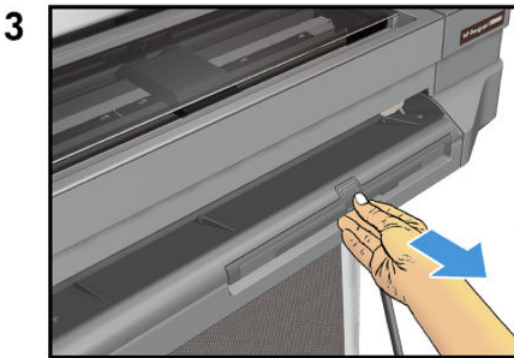
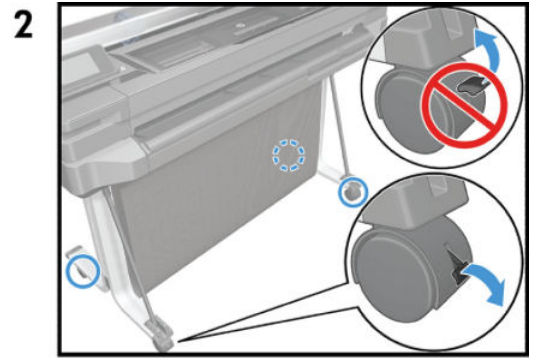

9

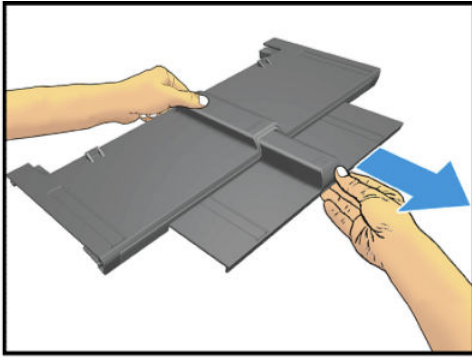

10

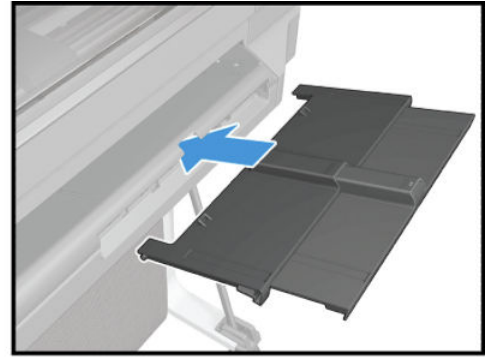

11

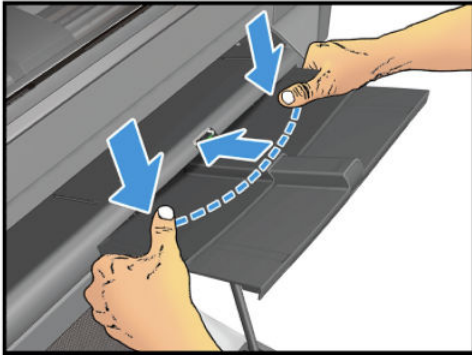

12

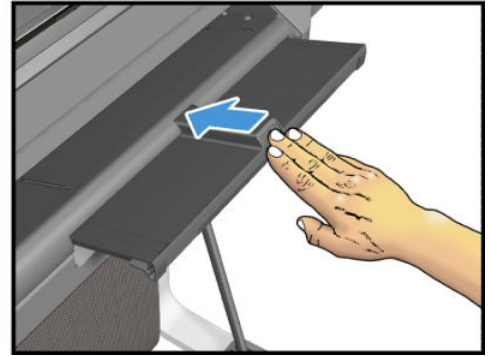

## Output Tray Sensor flier

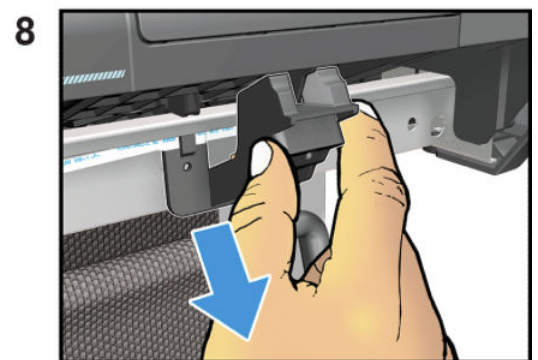
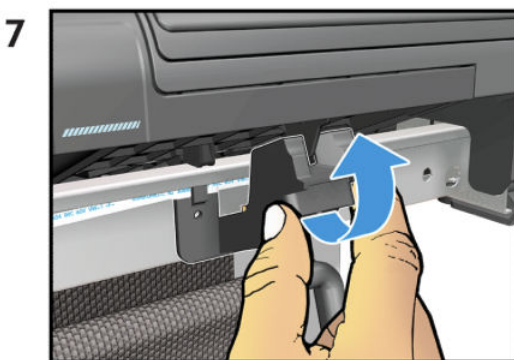
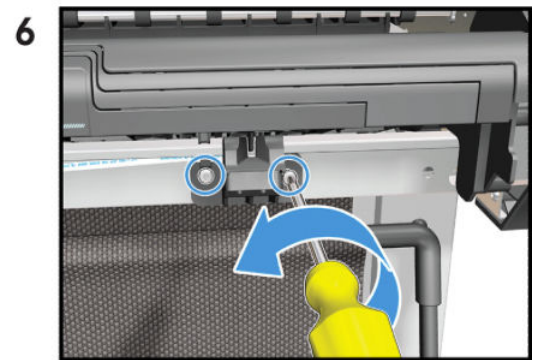
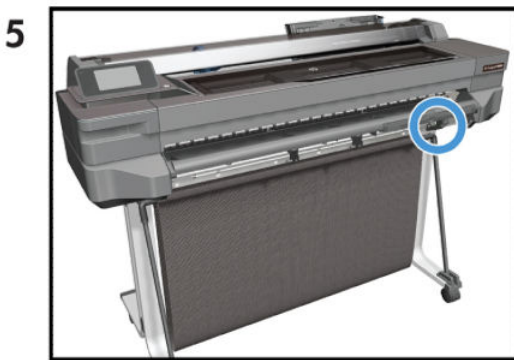
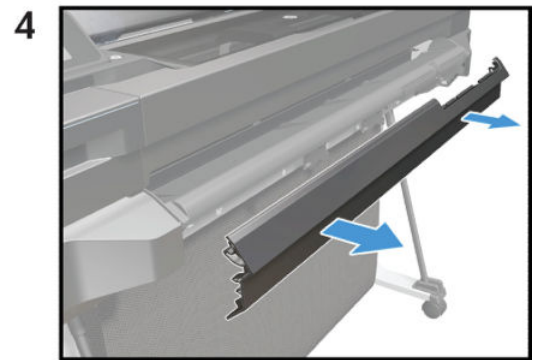
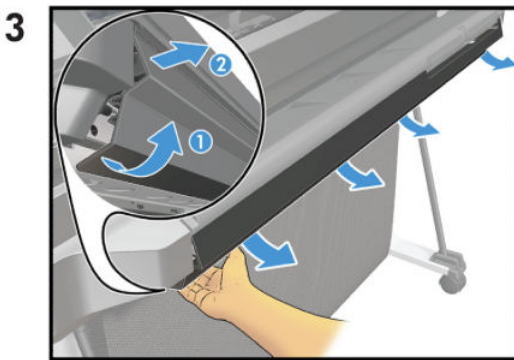
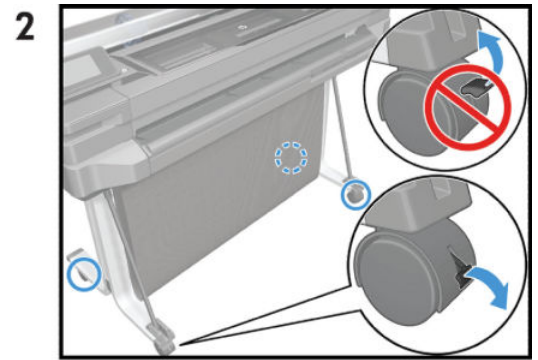

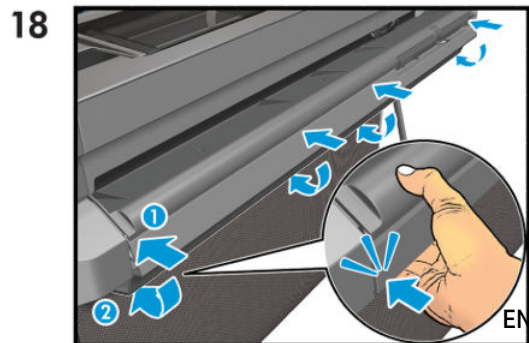
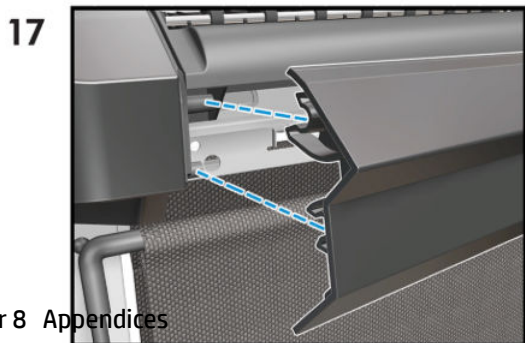
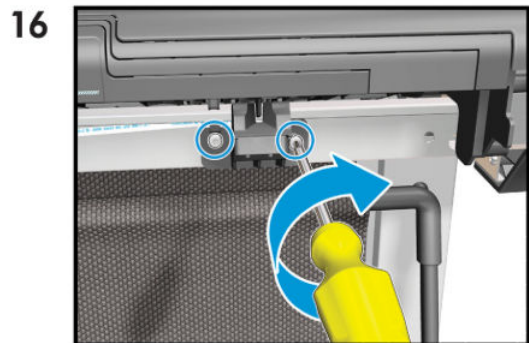
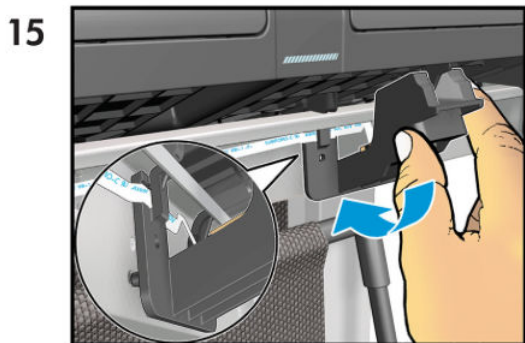
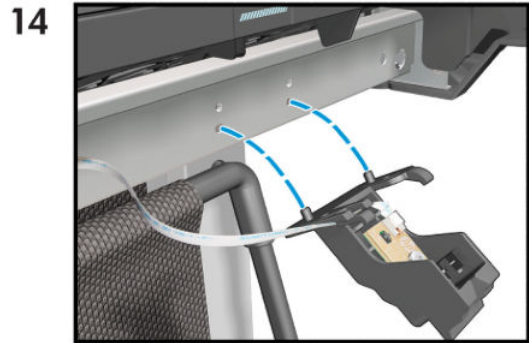
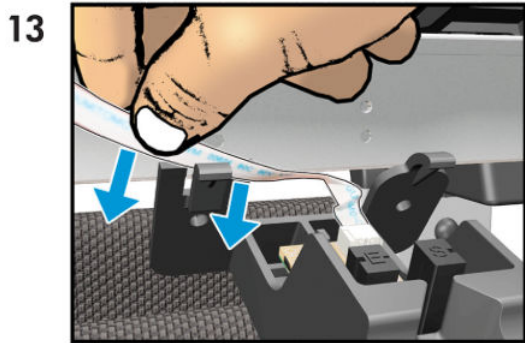
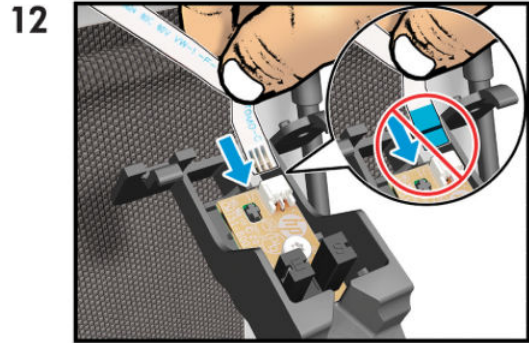
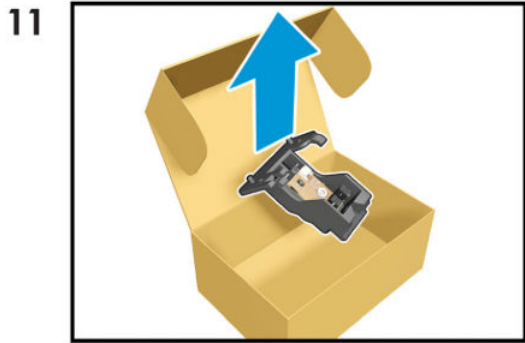
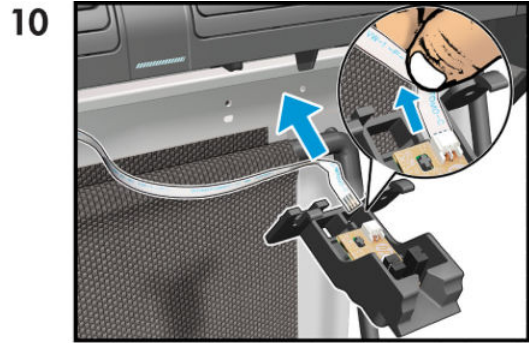
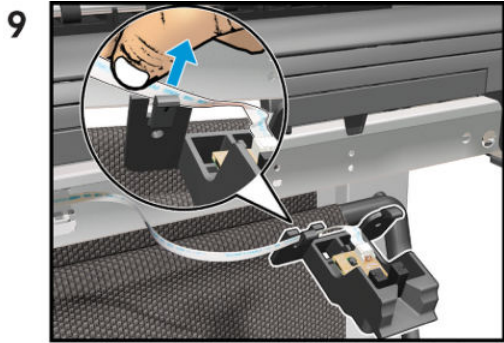

# Printhead Replacement Kit flier



1  
Image Quality Maintenance  
> Replace Printhead  
Maintenance de la qualité d'image  
> Rempl tête d'impression  
Bewahrung der Bildqualität  
> Druckkopf auswechseln

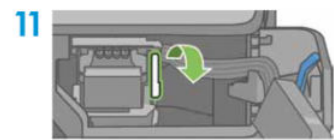
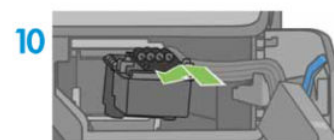
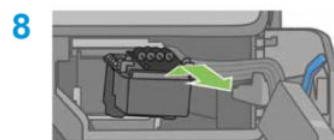
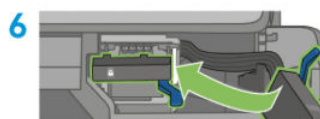
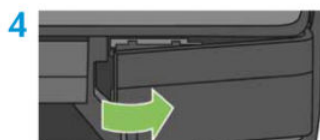
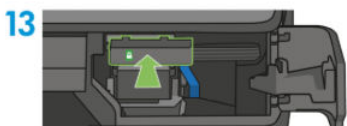
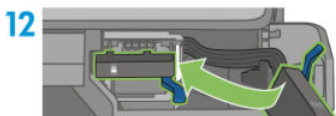

15  
If cartridge replacement is required,  
save used ones for later use  
Si un remplacement de cartouche est  
requis, veuillez conserver les cartouches  
usées pour une utilisation ultérieure  
Wenn eine Patrone ausgetauscht werden  
muss, sollten Sie gebrauchte zur späteren  
Verwendung aufbewahren



## 729

HP DesignJet Printhead  
Installation Guide

Guide d'Installation de  
la Tête D'Impression HP

HP DesignJet Druckkopf  
Installationsanleitung

For a superior combination of consistent, high-quality results, proven reliability and trouble-free printing, choose only Original HP Supplies. Original HP Supplies are specially designed to work with your HP printer.

Pour bénéficier d'une qualité exceptionnelle et de résultats constants, d'une fiabilité éprouvée et d'une impression sans soucis, choisissez toujours des consommables d'origine HP. Les consommables d'origine HP sont spécialement conçus pour votre imprimante HP.

## Scanbar replacement flier

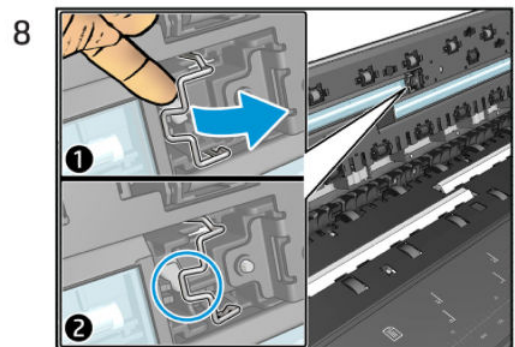
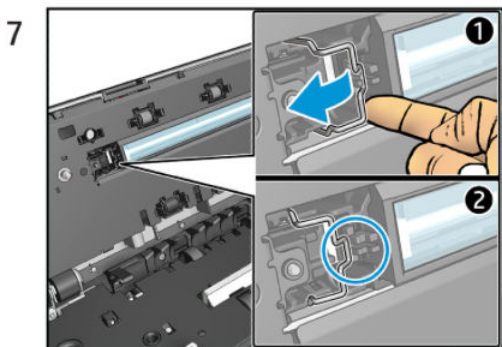
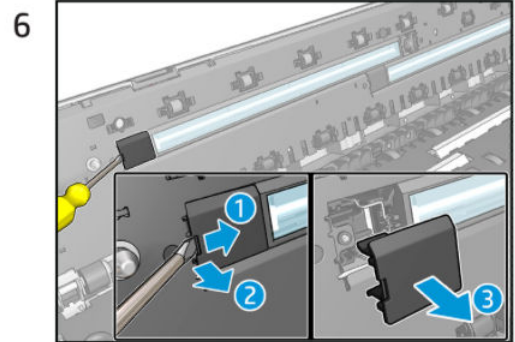
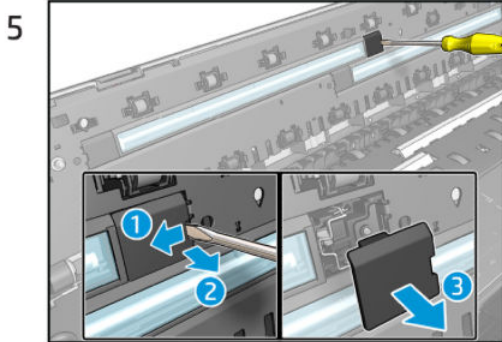
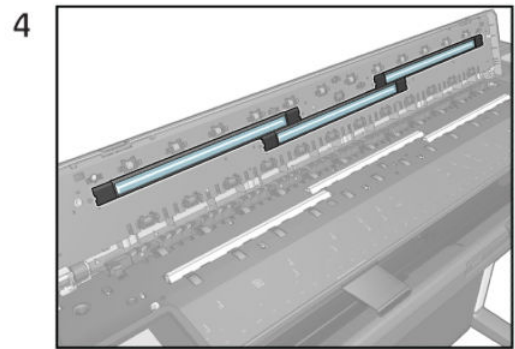
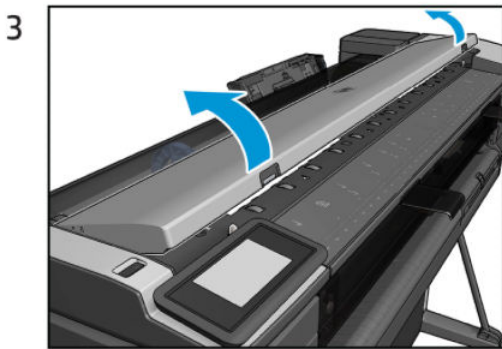
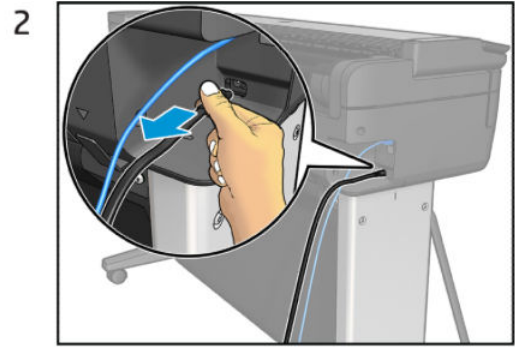
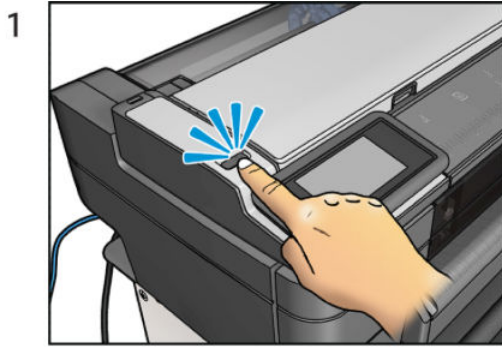



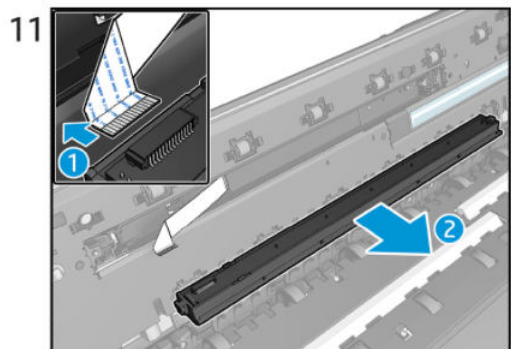
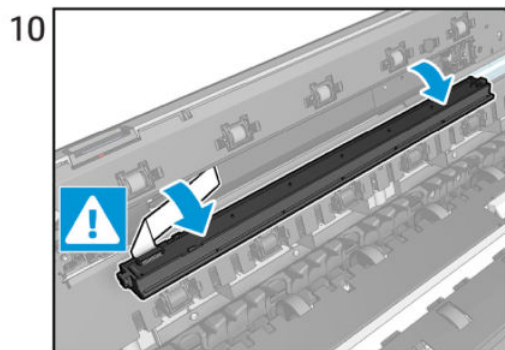
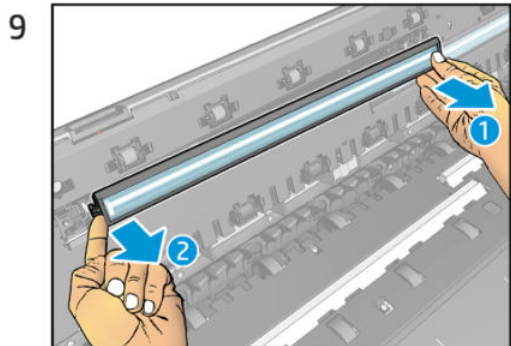

## Calibration Surface flier

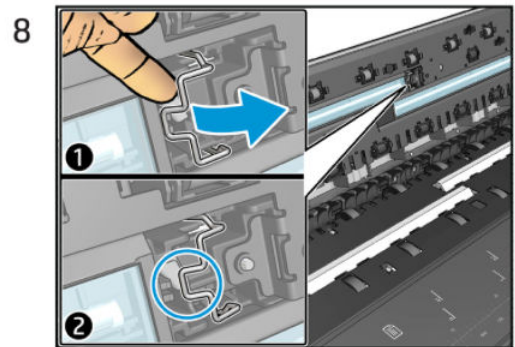
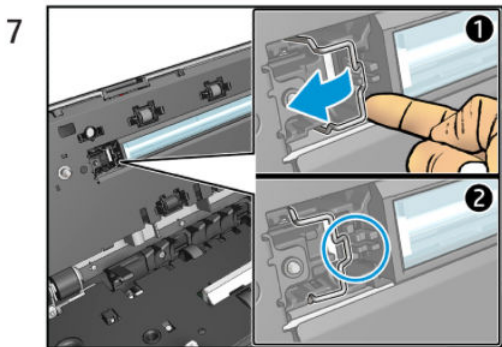
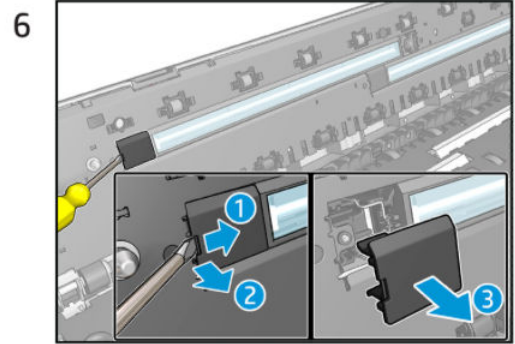
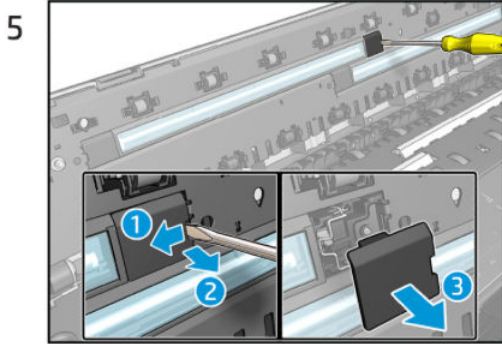
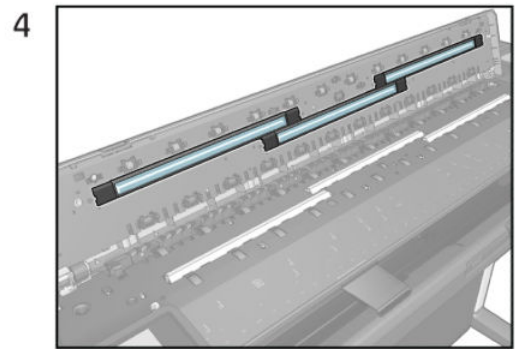
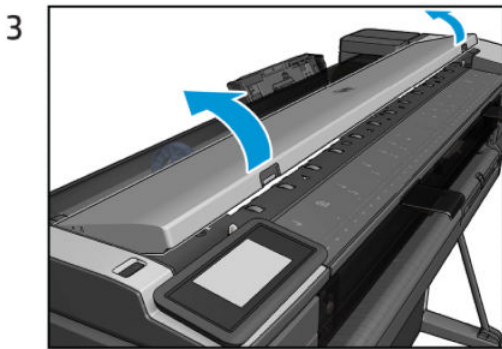
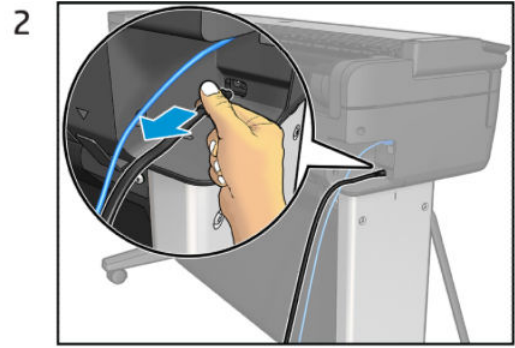
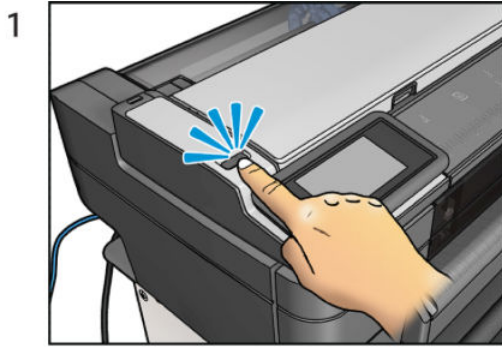

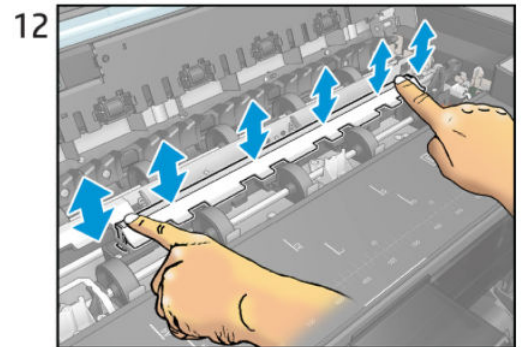
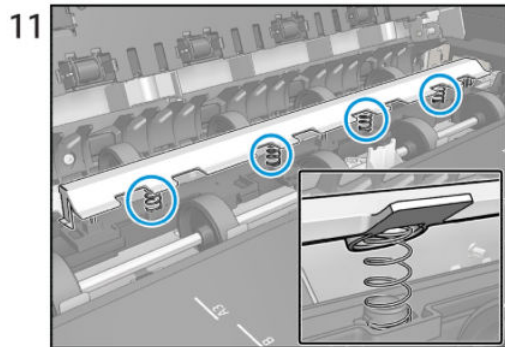
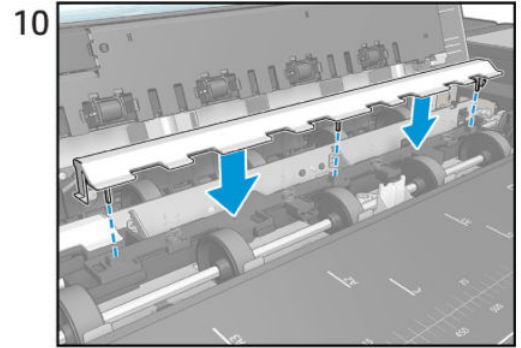
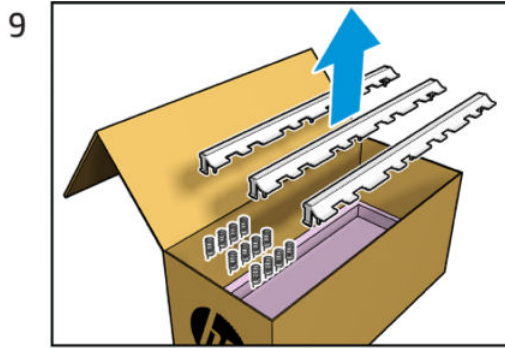

## Ink Door flier

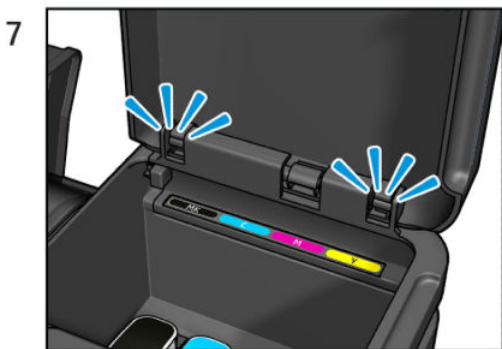
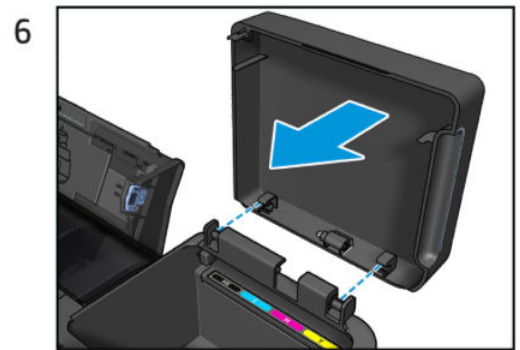
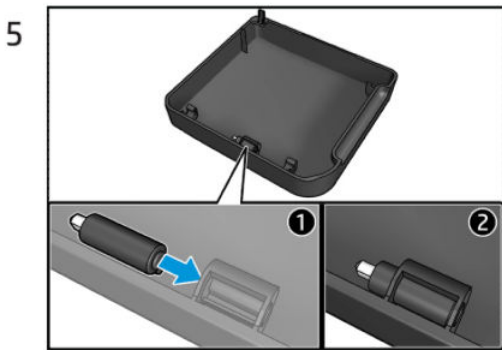
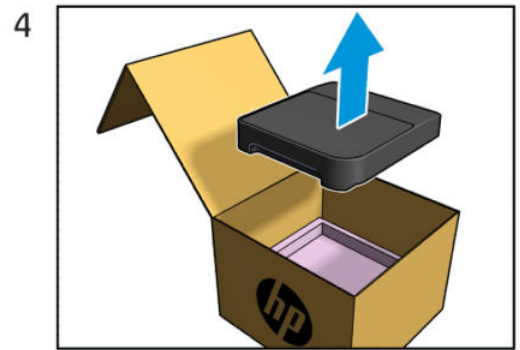
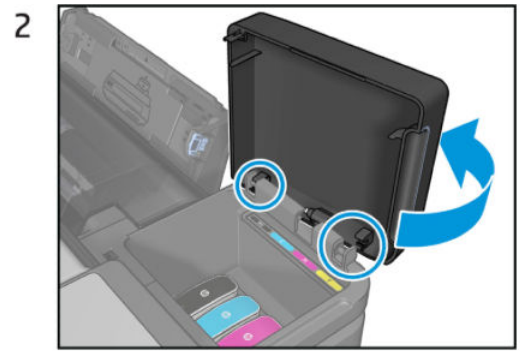
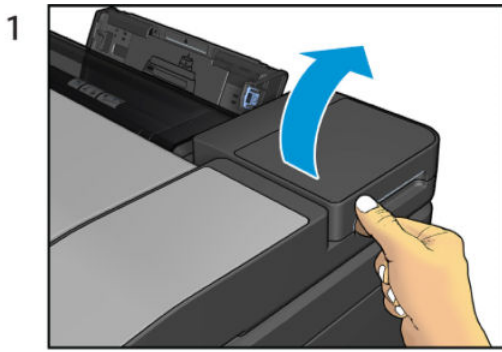

## Refeed Preventer flier

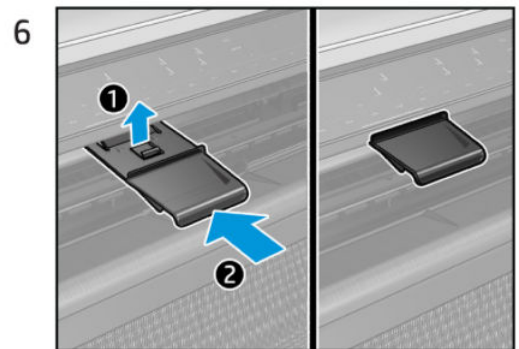
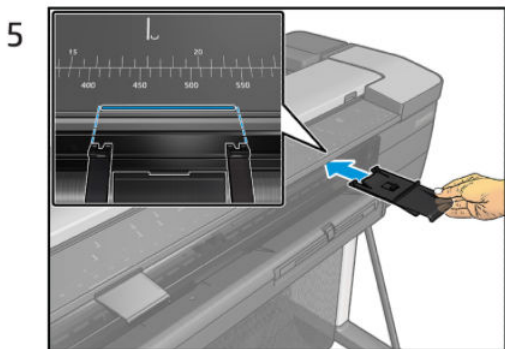
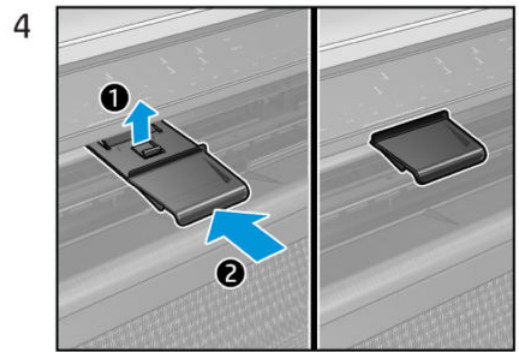
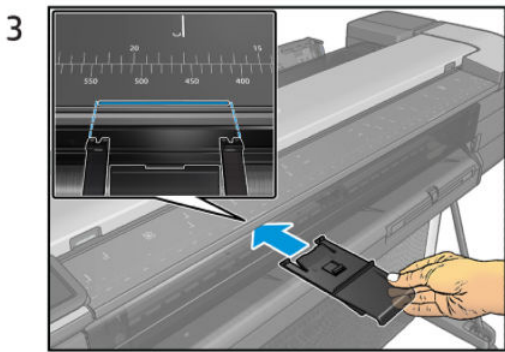
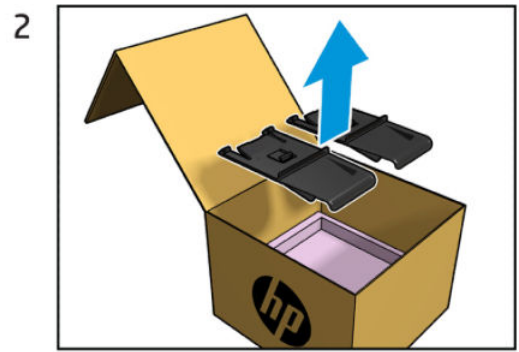
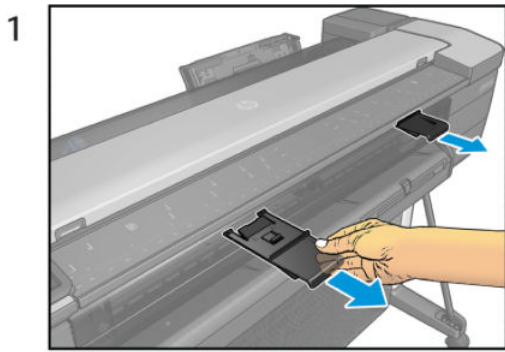

## Pressure Rollers flier

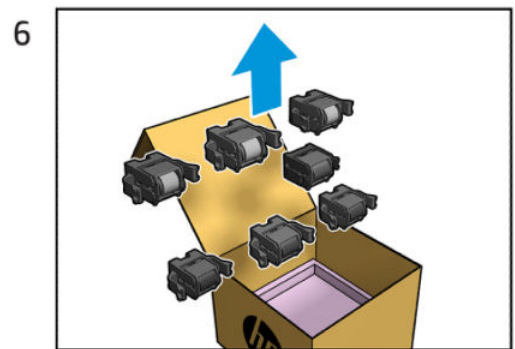
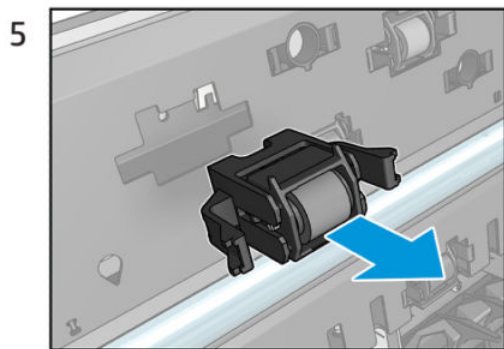
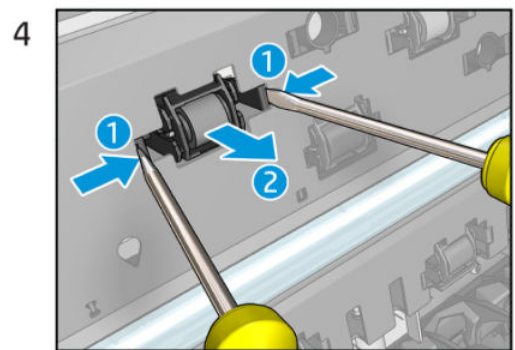
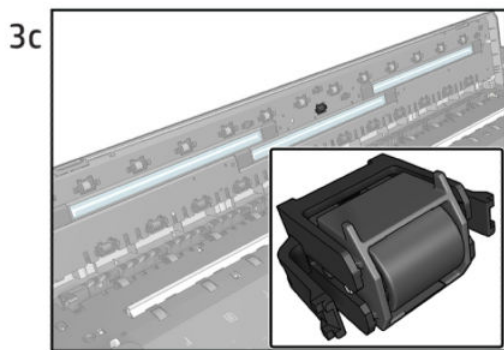
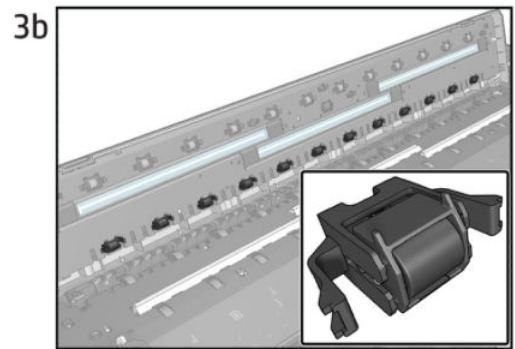
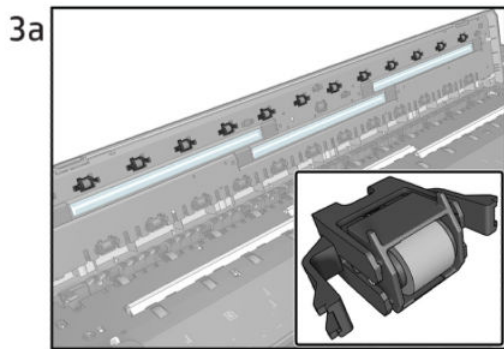
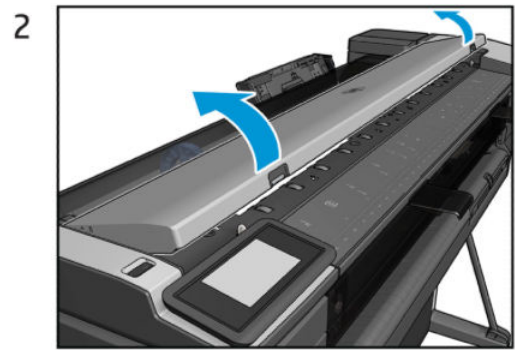
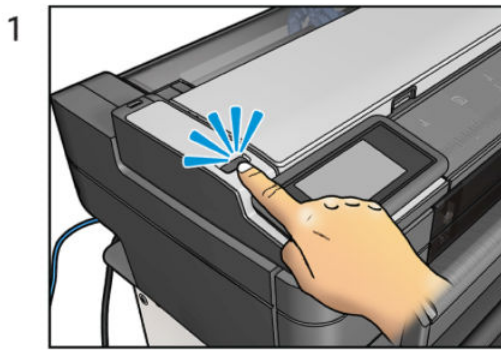

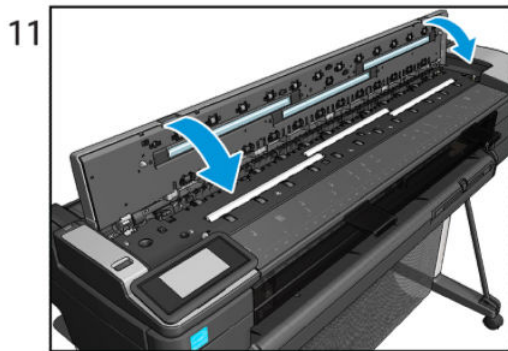
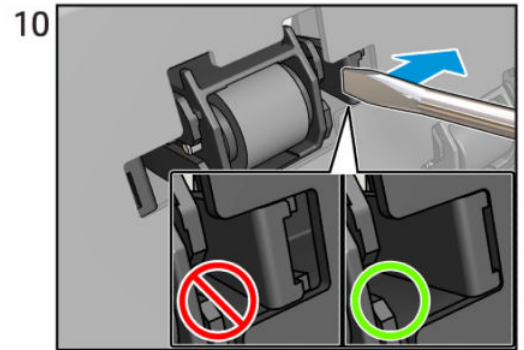
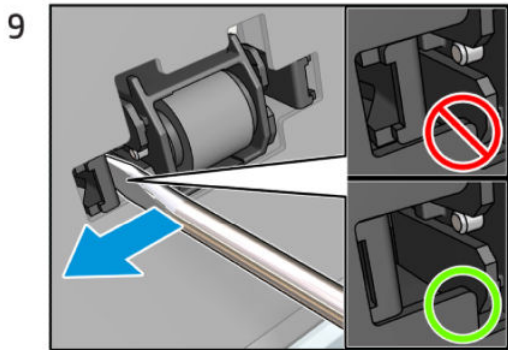
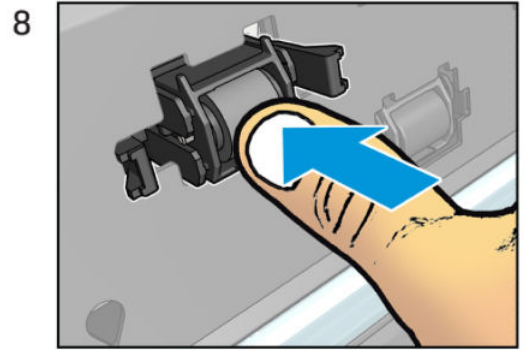
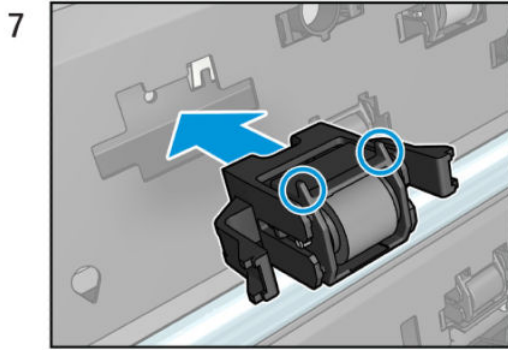

## Cutter flier

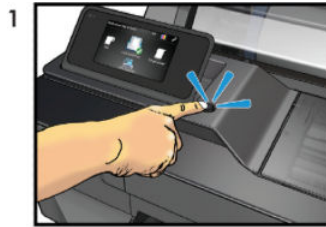

1. Switch off the printer.
2. Mettez l'imprimante hors tension.
3. Spegnere la stampante.
4. Drucker ausschalten.
5. Apague la impresora.
6. Desligue a impressora.
7. Отключите принтер.
8. 프린터 전원을 끕니다.
9. プリンタの電源を切ります。
10. 关闭打印机。
11. 關閉印表機。
12. Wyłącz drukarkę.

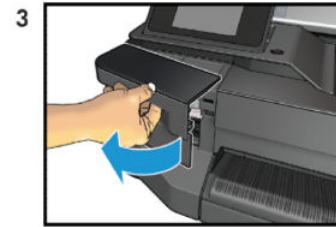

13. Open the ink cartridge cover.
14. Ouvrez le capot des cartouches d'encre.
15. Aprire il coperchio delle cartucce d'inchiostro.
16. Tintenbehälterabdeckung öffnen.
17. Abra la cubierta del cartucho de tinta.
18. Abra a tampa do cartucho de tinta.
19. Откройте крышку отсека с картриджами.
20. 잉크 카트리지 덮개 열기를 엽니다.
21. インクカートリッジカバーを開きます。
22. 打开墨盒盖。
23. 開啟墨水匣蓋子。
24. Otwórz pokrywę wkładów atramentowych.

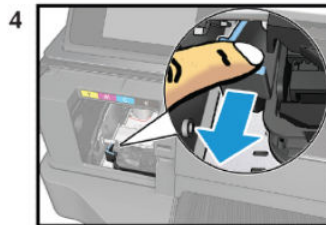

25. Pull the blue lever to release the cutter.
26. Tirez le levier bleu pour libérer le coupeur.
27. Tirare la leva blu per rilasciare la taglierina.
28. Blauen Hebel ziehen, um Schneidvorrichtung freizugeben.
29. Tire de la palanca azul para soltar la cuchilla.
30. Puxe a alavanca azul para liberar o cortador.
31. Потяните за синий рычаг, чтобы освободить резак.
32. 파란색 레버를 당겨 절단기를 분리합니다.
33. ピンチレバーを引いてカッターから外します。
34. 拉动蓝色手柄松开裁纸器。
35. 拉動藍色手柄以鬆開裁紙器。
36. Pociągnij niebieską dźwignię, aby zwolnić obcinarkę.



37. Remove the cutter.
38. Retirez le coupeur.
39. Rimuovere la taglierina.
40. Schneidvorrichtung entfernen.
41. Extraiga la cuchilla.
42. Remova o cortador.
43. Удалите резак.
44. 절단기를 제거합니다.
45. カッターを取り外します。
46. 卸下载纸器。
47. 取出裁紙器。
48. Wyjmij obcinarkę.

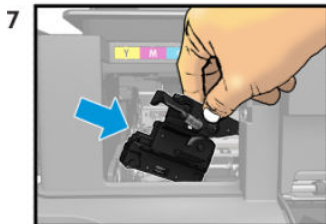
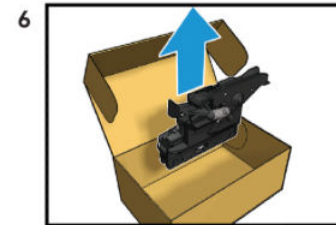

49. Insert the new cutter.
50. Insérez le nouveau coupeur.
51. Inserire la nuova taglierina.
52. Neue Schneidvorrichtung einsetzen.
53. Inserte la cuchilla nueva.
54. Insira o novo cortador.
55. Вставьте новый резак.
56. 새 절단기를 삽입합니다.
57. 新しいカッターを差し込みます。
58. 插入新裁纸器。
59. 插入新的裁紙器。
60. Włóż nową obcinarkę.

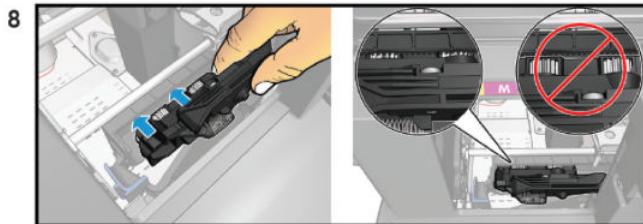

61. Engage two white gears under the rack. Note: The cutter should be loose (not blocked).
62. Enclenchez les deux roues dentées blanches sous le support. Remarque : Le coupeur doit être desserré (non bloqué).
63. Innestare i due ingranaggi bianchi sotto la cremagliera. Nota: la taglierina deve risultare allentata, non bloccata.
64. Weiße Zahnräder unter dem Rack betätigen. Hinweis: Die Schneidvorrichtung muss lose sein (nicht blockiert).
65. Encaje las dos ruedas dentadas de color blanco debajo de la cremallera. Nota: la cuchilla debe quedar suelta (sin bloquear).
66. Prenda as duas engrenagens brancas debaixo do rack. Nota: O cortador deve estar solto (não bloqueado).
67. Зацепите две белые шестерни под стойкой. Примечание: Резак должен свободно перемещаться.
68. 맥 아래에 있는 2개의 흰색 기어에 끼웁니다. 참고: 절단기는 막혀 있지 않고 느슨해야 합니다.
69. 2つの白いギアをラックの下に取り付けます。注記: カッターは自由に動くようにします (固定しないでください)。
70. 使机架下方的白色齿轮啮合。注: 裁纸器应处于松开状态 (未固定)。
71. 將兩個白色齒輪接合到齒軌下方。注意: 裁紙器應該是可活動的 (未受阻擋)。
72. Umieść w gnieździe dwa białe koła zębate. Uwaga: obcinarka nie powinna być zablokowana.



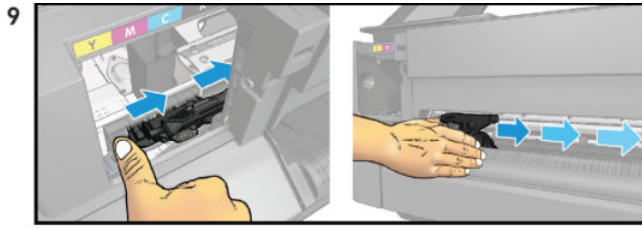

- EN Move the cutter to the center of the printer. If blocked, go back to step 5.
- FR Placez le coupeur au centre de l'imprimante. S'il est bloqué, passez à l'étape 5.
- IT Spostare la taglierina al centro della stampante. Se è bloccata, tornare al passaggio 5.
- DE Schneidvorrichtung in die Mitte des Druckers verschieben. Bei Blockierung zurück zu Schritt 5.
- ES Mueva la cuchilla hacia el centro de la impresora. Si queda bloqueada, regrese al paso 5.
- PT Mova o cortador para o centro da impressora. Se estiver bloqueado, volte para a etapa 5.
- RU Переместите резак к центру принтера. Если он не двигается, вернитесь к шагу 5.
- KO 절단기를 프린터의 중앙으로 이동합니다. 막혀 있는 경우, 5단계로 돌아갑니다.
- JA カッターをプリンタの中央に移動します。カッターが動かない場合は、手順5に戻ります。
- CHN 將裁紙器移動到打印機的中央位置。如果被卡住，請返回到步驟 5。
- CHN 將裁紙器移至印表機的中間。如果受到阻擋，請回到步驟 5。
- PL Przesuń obcinarkę do środka drukarki. Jeśli jest zablokowana, przejdź do kroku 5.

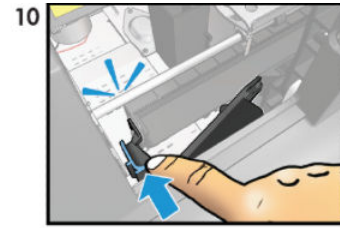

- EN Push the blue lever until it 'clicks'.
- FR Poussez le levier bleu jusqu'à ce qu'il s'endèche.
- IT Spingere la leva blu finché non scatta in posizione.
- DE Blauen Hebel drücken, bis er hörbar einrastet.
- ES Empuje la palanca azul hasta que haga "clic".
- PT Empurre a alavanca azul até travar.
- RU Нажмите на синий рычаг до щелчка.
- KO 파란색 레버를 '딸깍' 소리가 날 때까지 누릅니다.
- JA ピンチレバーをカチッと音がするまで押します。
- CHN 推動藍色手柄，直到聽到“咔嚓聲”。
- CHN 推動藍色手柄，直到它發出喀聲。
- PL Naciskaj niebieską dźwignię, aż się zatrzaśnie.

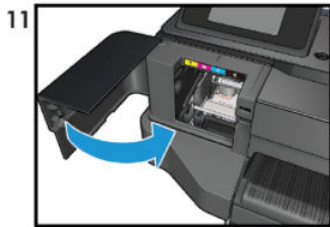

- EN Close the ink cartridge cover.
- FR Fermez le capot des cartouches d'encre.
- IT Chiudere il coperchio delle cartucce d'inchiostro.
- DE Tintenbehälterabdeckung schließen.
- ES Cierre la cubierta del cartucho de tinta.
- PT Feche a tampa do cartucho de tinta.
- RU Закройте крышку отсека с картриджами.
- KO 잉크 카트리지 덮개를 닫습니다.
- JA インクカートリッジカバーを閉じます。
- CHN 蓋上墨盒蓋。
- CHN 關閉墨水匣蓋子。
- PL Zamknij pokrywę wkładów atramentowych.



- EN Turn the printer on and ensure that a roll is loaded. Press the setup icon and select Form feed & cut.
- FR Allumez l'imprimante et assurez-vous que le rouleau est chargé. Appuyez sur l'icône de configuration et sélectionnez Avance et coupe papier.
- IT Accendere la stampante e assicurarsi che sia caricato un rotolo. Premere l'icona d'impostazione e selezionare Avanzamento e taglio carta.
- DE Drucker einschalten und überprüfen, ob eine Rolle geladen ist. Setup-Symbol drücken und Formularzufuhr und -schnitt auswählen.
- ES Encienda la impresora y asegúrese de que haya un rollo cargado. Pulse el icono de configuración y seleccione Avanza y corta hoja.
- PT Ligue a impressora e verifique se o rolo está carregado. Pressione o ícone de configuração e seleccione Alimentar e cortar formulário.
- RU Включите принтер и убедитесь, что рулон загружен. Нажмите значок настройки и выберите Прогон листа и обрезка.
- KO 프린터가 켜진 후 롤이 로드되었는지 확인합니다. 설정 아이콘을 누른 후 용지 바꿈/자동 절단을 선택합니다.
- JA プリンタの電源を入れ、ロール紙が取り付けられていることを確認します。セットアップアイコンを押し、[排紙/カット]を選択します。
- CHN 打开打印机，并确保装入了卷筒。按设置图标并选择“进纸并剪切”。
- CHN 開啟印表機並確定捲筒紙已裝入。按下設定圖示然後選擇進紙並裁切。
- PL Włącz drukarkę i upewnij się, że rola jest załadowana. Naciśnij ikonę konfiguracji i wybierz opcję Wysłunięcie i obcięcie strony.

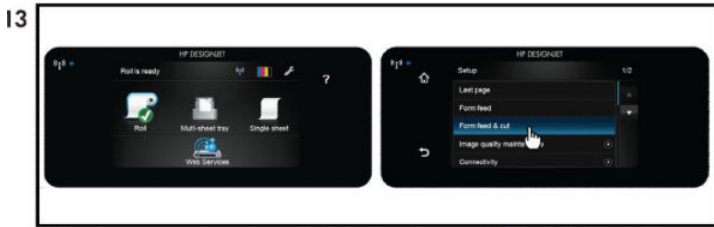

- EN Turn the printer on and ensure that a roll is loaded. Press the setup icon and select Form feed & cut.
- FR Allumez l'imprimante et assurez-vous que le rouleau est chargé. Appuyez sur l'icône de configuration et sélectionnez Avance et coupe papier.
- IT Accendere la stampante e assicurarsi che sia caricato un rotolo. Premere l'icona d'impostazione e selezionare Avanzamento e taglio carta.
- DE Drucker einschalten und überprüfen, ob eine Rolle geladen ist. Setup-Symbol drücken und Formularzufuhr und -schnitt auswählen.
- ES Encienda la impresora y asegúrese de que haya un rollo cargado. Pulse el icono de configuración y seleccione Avanza y corta hoja.
- PT Ligue a impressora e verifique se o rolo está carregado. Pressione o ícone de configuração e seleccione Alimentar e cortar formulário.
- RU Включите принтер и убедитесь, что рулон загружен. Нажмите значок настройки и выберите Прогон листа и обрезка.
- KO 프린터가 켜진 후 롤이 로드되었는지 확인합니다. 설정 아이콘을 누른 후 용지 바꿈/자동 절단을 선택합니다.
- JA プリンタの電源を入れ、ロール紙が取り付けられていることを確認します。セットアップアイコンを押し、[排紙/カット]を選択します。
- CHN 打开打印机，并确保装入了卷筒。按设置图标并选择“进纸并剪切”。
- CHN 開啟印表機並確定捲筒紙已裝入。按下設定圖示然後選擇進紙並裁切。
- PL Włącz drukarkę i upewnij się, że rola jest załadowana. Naciśnij ikonę konfiguracji i wybierz opcję Wysłunięcie i obcięcie strony.

## Stand Left Leg flier

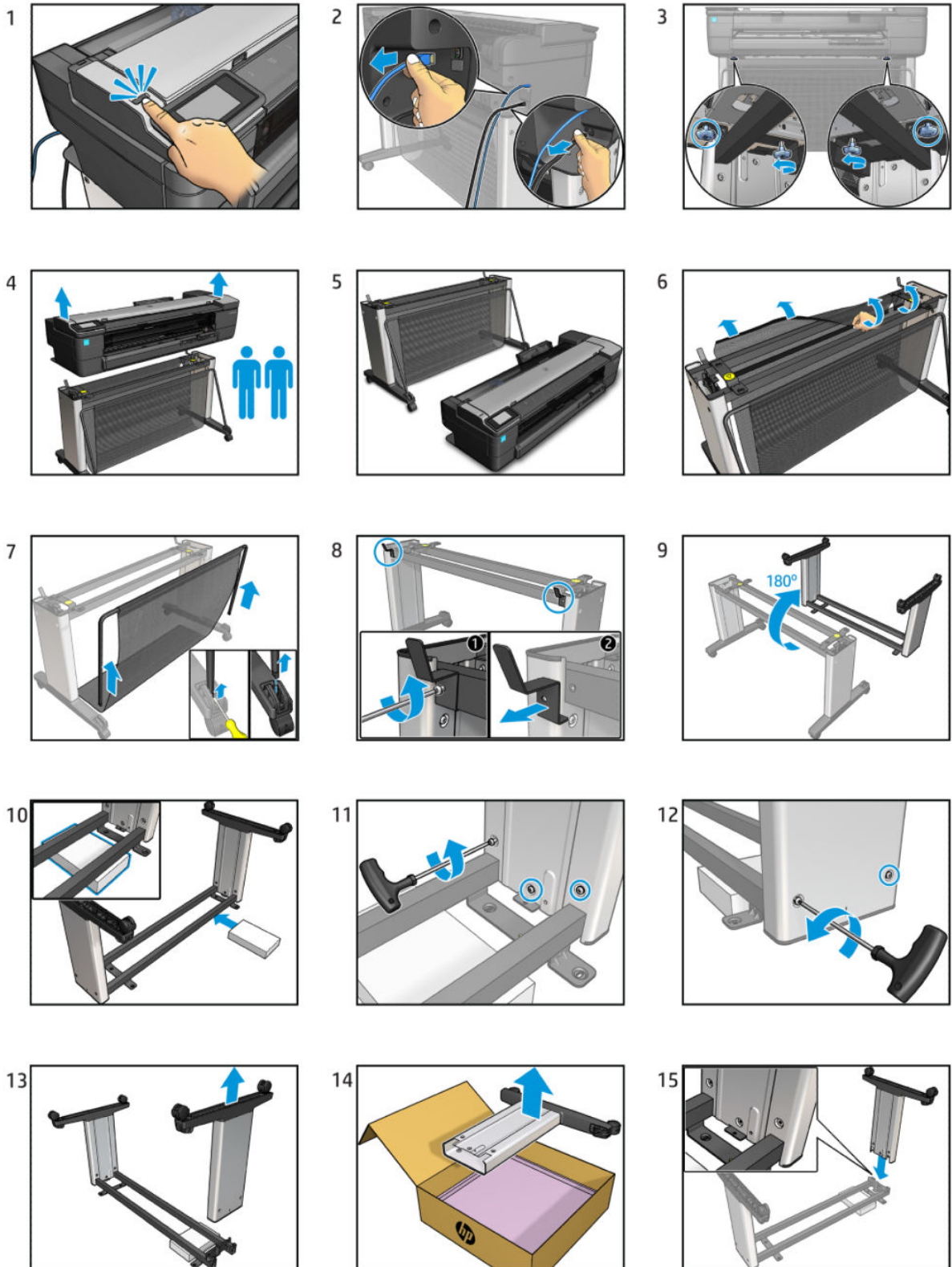

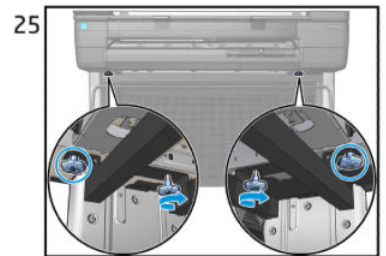
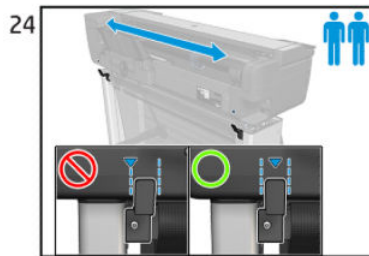
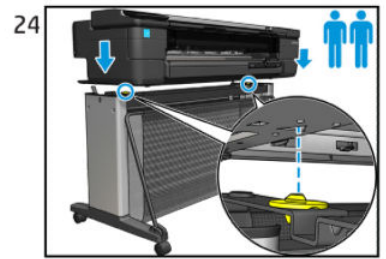
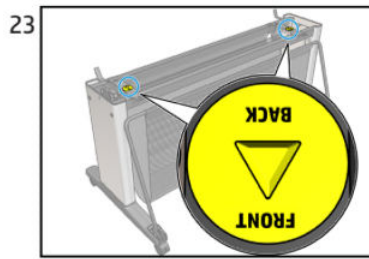
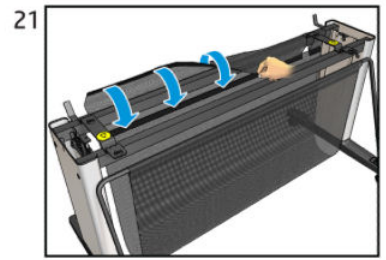
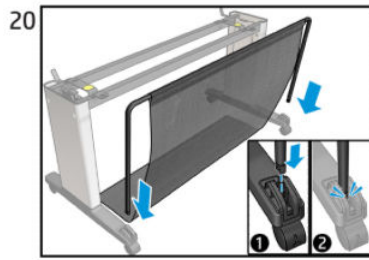
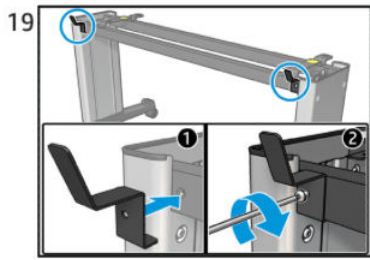
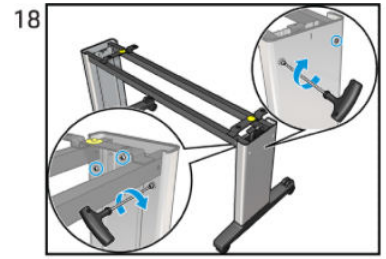
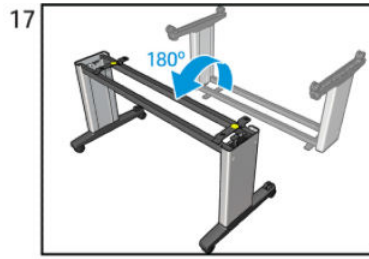
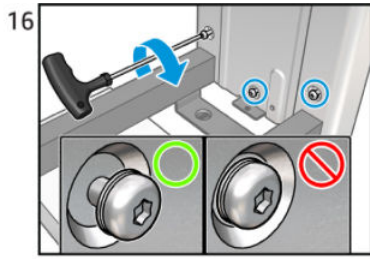

## Stand Right Leg flier

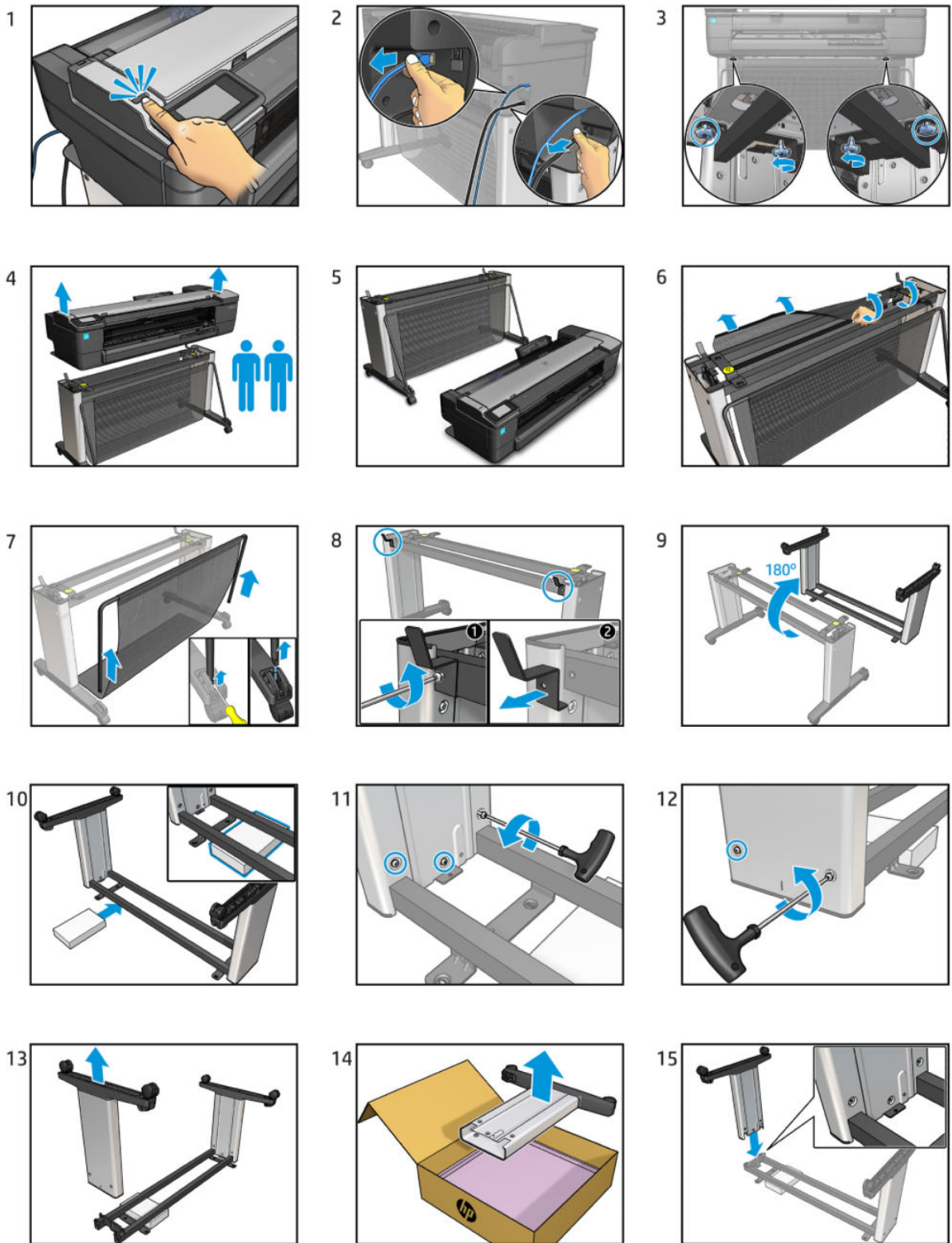

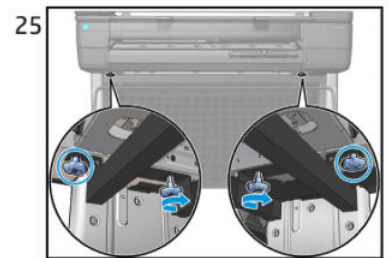
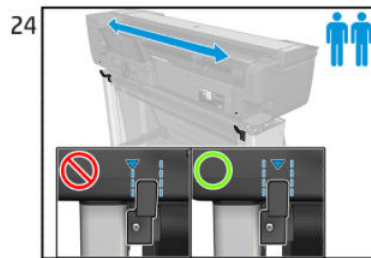
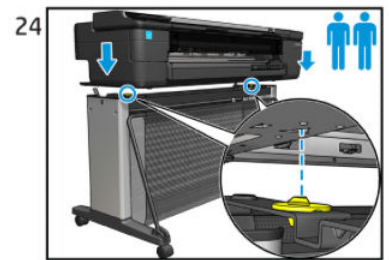
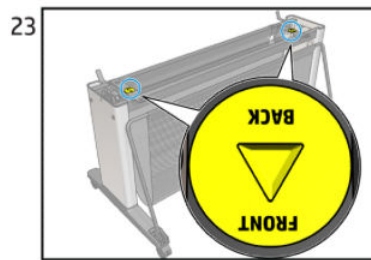
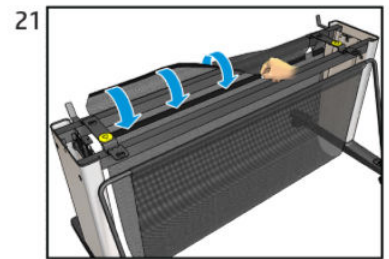
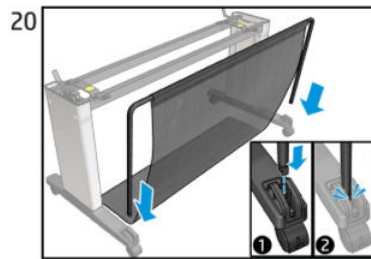
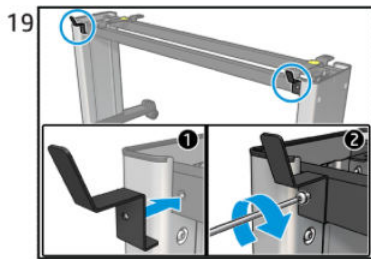
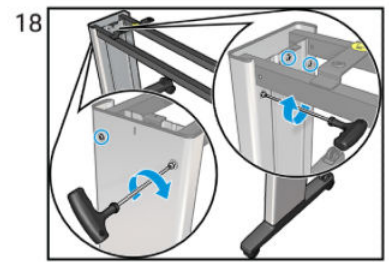
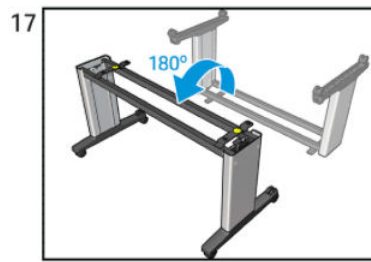
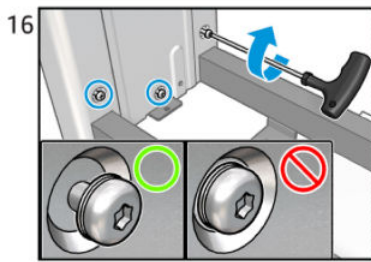

## Stand Basket flier

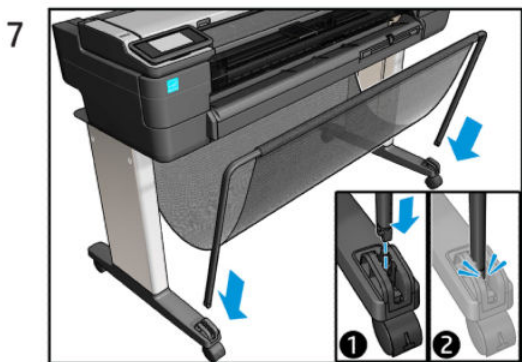
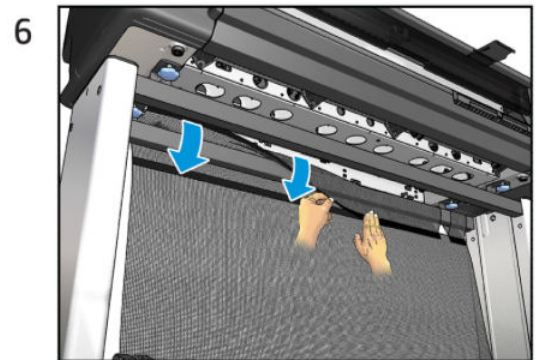
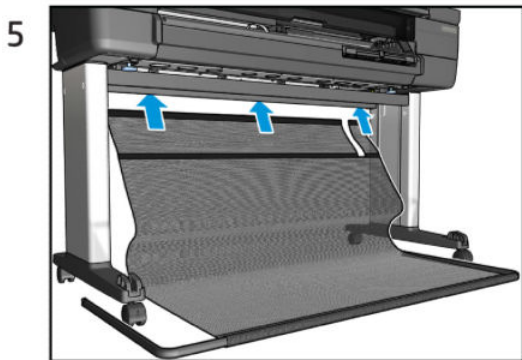
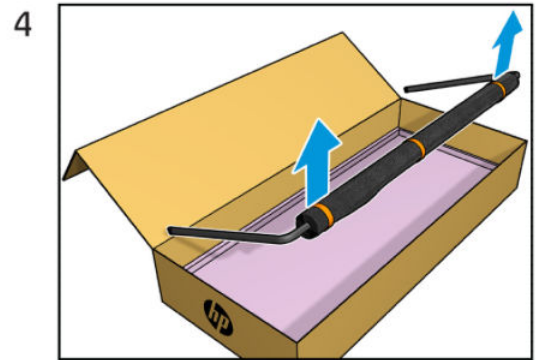
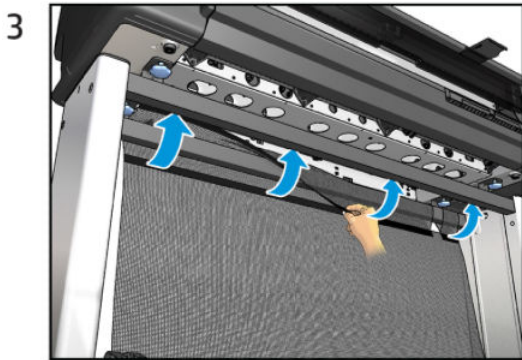
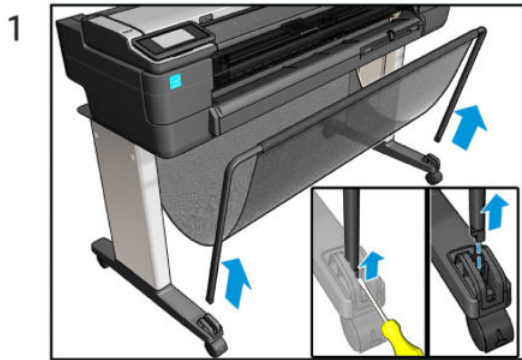

## Printhead Door flier

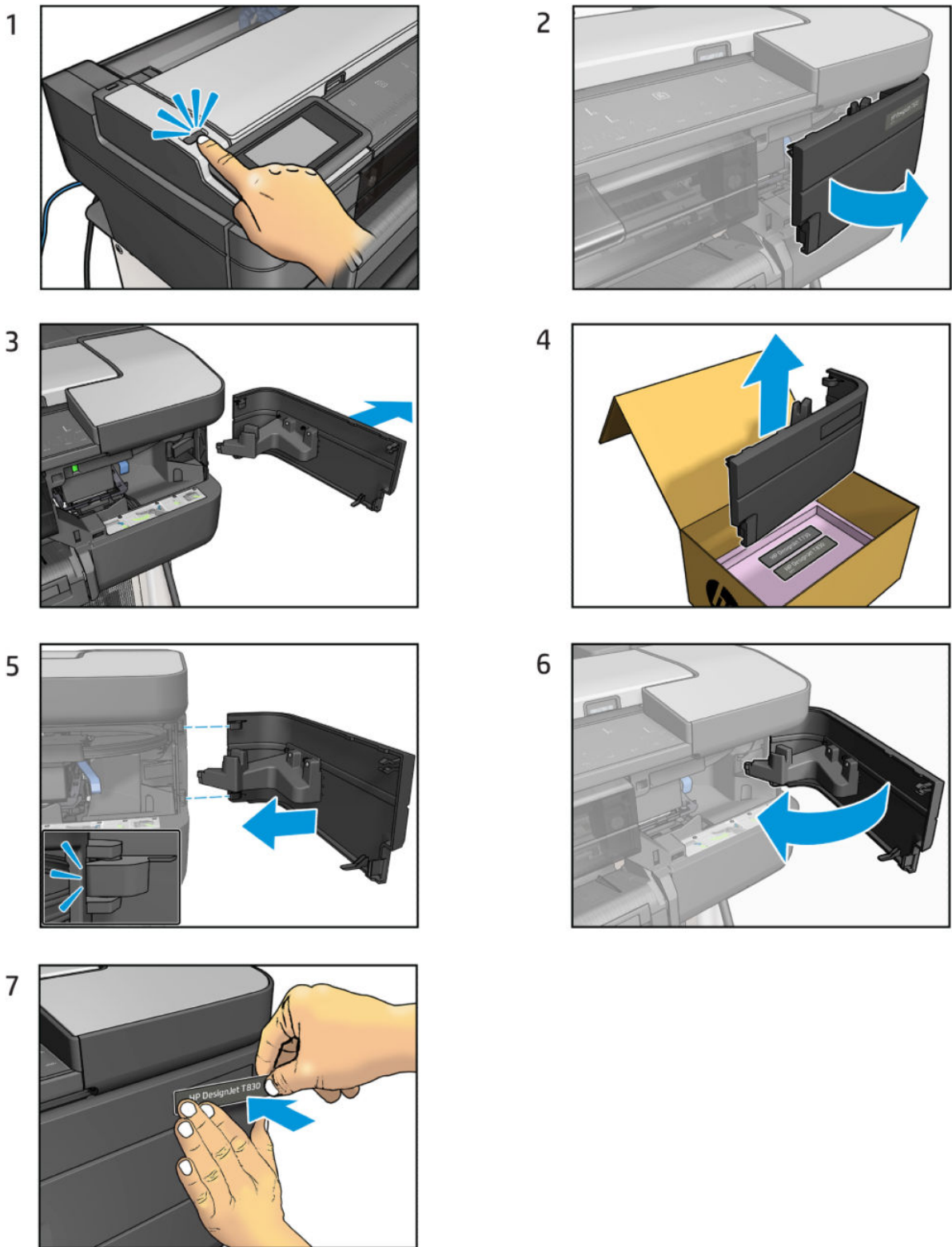

# FAQ: Tips & Tricks

- [1. Image Quality](#)
- [2. Scan and Copy](#)
- [3. Hardware](#)
- [4. Firmware](#)
- [5. Software and Drivers](#)
- [6. Network](#)

## 1. Image Quality

### Banding when printing area fills on Plain paper in normal mode

**Question:** When printing on Plain Paper media in Normal print mode, I get horizontal banding in area fills.

**Answer:** This is a common issue known of T730/T830 and T120/T520 printers. For the T730/T830 there will be a specific print mode called “Plain Paper for Graphics” in FW VR3 (ETD: Jun’16) that will fix this issue. For the time being, we can recommend that the customer set the paper as “coated” in the Front Panel. This will improve IQ.

## 2. Scan and Copy

### Differences between Scan&Print and Copy

**Question:** Color performance behavior of the unit when you “scan and print” differs from when you “copy.”

**Answer:**

- In the “Copy” flow the priority is to create a copy that most closely resembles the original.
- In the “Scan & Print” flow, the printing color map is optimized for printing (from applications). The “scan” flow is optimized for display in monitors. The combination of both flows show “less vivid” print-outs.

One workaround to get better output is to use ICC profiles. Adobe applications (and some non-Adobe applications) support ICC profiles without any issues.

### TIFF scanning has some limitations

**Question:** I cannot print a TIFF file generated in a scan of the unit (T830MFP).

**Answer:** This is a temporary product limitation that will be solved in the next firmware release (VR2.1) scheduled at the end of Mar’16.

**Question:** I cannot open a TIFF file generated in a scan of the unit (T830MFP) with the Adobe Photoshop application.

**Answer:** This is a temporary product limitation that will be solved with the next firmware release (VR2.1) scheduled for the end of Mar’16

**Question:** When working with a TIFF file generated in a scan of the unit (T830MFP), I have lost image accuracy.



**Answer:** Only black & white scans (PDF, TIFF) are compressed with a lossless compression method (Fax Group 4 compression). Color and greyscale scans (PDF, JPEG, TIFF) are currently always compressed using JPEG, so they are indeed lossy.

## Webscan disabled in EWS

**Question:** I cannot scan to PC with the EWS.

**Answer:** The Webscan option is disabled by default in the EWS. You can enable it in **EWS ► Settings ► Security ► Administrator Settings** .

## Orange line when copying

**Question:** When I copy or scan my original I can see an orange line/area on one edge.



**Answer:** This is caused by excessive skew when loading the original. Try to load the original centered and without any skew. Ultimately, disable the “Auto Deskew” option in Front Panel settings.

## How to scan in Windows Server 2012

**Question:** When installing the printer using the Add Device wizard in Windows Server 2012, Scan service options (**Start Scan ► Scan Profiles ► Scan properties**) are not installed.

**Answer:** You must first install the “Desktop Experience” Server Manager feature. After that, proceed to installing the printer queue again: the scan options will be shown. Below, a photo showing the location of the “Desktop Experience” feature.

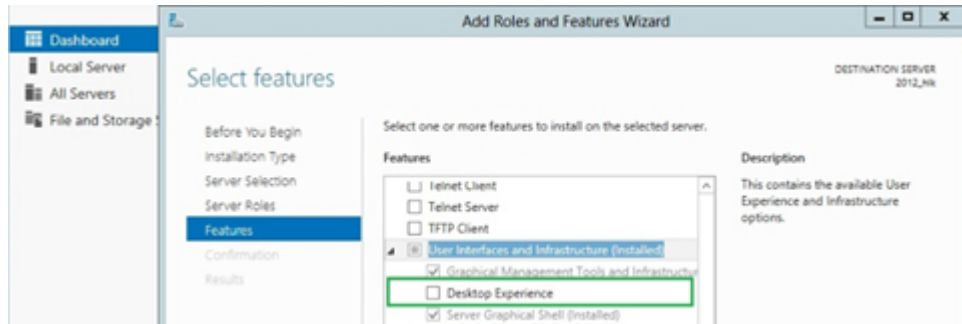

## Rotate option not available in Copy flow

**Question:** How does one manage a scanned job to be printed out as rotated in the Copy workflow?

**Answer:** There is no rotation option in the Copy workflow; in order to print a job with the correct orientation you must scan the job using the same orientation by which you want to have it printed.

## Printer freezes at Eject screen when scanning from HP All in One app and EWS

**Question:** The printer is frozen at the Eject scan screen. The scanned paper has been already ejected but the screen keeps showing the eject message.

**Answer:** When using the scan feature from the HP All in One app and EWS, in some cases the printer may become frozen at the Eject screen. The occurrence/frequency of this issue is very low. In order to get the unit to recover, you must reboot it.

## Dark background blueprints not inverted in Best print mode

**Question:** Original blueprints with dark backgrounds are copied with the Blueprint setting activated in different sizes and print modes.

For all copied media sizes, both the Fast and Normal print modes work as expected: the output has the expected dark lines on a white background.

But with the Best print mode, printer doesn't invert the image and it is printed with a dark background, just like the original image.

**Answer:** This is a known limitation. The Best copy mode scans at a higher resolution (600 dpi) than the other two modes. With the higher resolution scans (600 dpi), the scanned length is analyzed in order to detect the background color, but the printer detects white background (margins) instead of blue backgrounds.

## Max copy length is 2.7 meters

**Question:** What is the maximum media length we can copy?

**Answer:** The maximum copy length is 2.7 meters. The Long plot scan mode (8 meters) only applies to scanning.

## Long plot in VR2.1

**Question:** Printer (T830 MFP) will not scan beyond 2.7 m in length.

**Answer:** This is the expected performance for every mode and resolution. They all scan 2.7 m. In case you want to scan longer plots, there will be a "Long plot scan" mode available in the firmware to be released at the end of Mar'16. You will be able to scan up to 8 meters (initially it was only 7.2 m).

### Scan to Network Folder setup

**Question:** When setting up the Scan to Network Folder, the Network Path is not recognized.

**Answer:** It is highly recommended to use the computer *IP address* instead of the *Computer name* in the network path.

### 3. Hardware

#### Chinese language not available in EMEA and AMS regions

**Question:** I have bought a unit in EMEA or AMS and the Chinese language is not available.

**Answer:** The Chinese language is only available in the APJ product version (F9A29B and F9A30B).

#### Rubber stand transferred to cover

**Question:** Covers are hard to remove in a service operation; they seem stuck.



**Answer:** In the first 4,000 units, there is an interference between the rubber protector in the leg stand and the cover. In order to make cover removal easier, untighten the bottom screws that fix the printer to the stand,



and lift the printer off the stand a little bit at the same time you are pulling the cover off. If you are not untightening screws completely, ensure that the printer does not fall from the stand.

**Solution:** For customers that will not accept this minor limitation a solution can be provided on a case-by-case basis. Two spacers are added to each stand leg in order to raise the printer and remove the interference between the printer and the stand. An escalation to GBU should be opened in order to request the parts.

### Solution for these units



### Multi-sheet tray sensor bracket - Cable Cover loose

**Question:** When I open the roll cover, it hits the black Multi-sheet tray cover and falls out of place.



**Answer:** The black cover can be replaced back. There are no screws, it just snaps in. Customer can perform. However the issue can happen repeatedly. If the CE visit is needed, CE should compress the metal bracket so it retains the black cover better:



There will be a new design in the long term.

### Noise issues while printing

**Question:** Customer claims there is noise while printing.

**Answer:** There are different sources for this generic “noise.” Listed here are common sources:

1. The Starwheel hanger is misassembled and the Carriage rubs against it.

2. The blue ink tubes latch was not assembled properly on the manufacturing line and it rubs against the Starwheel hanger as the Carriage moves.



3. The Trailing cable may not be properly guided and some uncontrolled dynamics then occur, causing some whiplash/snap noises.



4. Ink tubes may have a twist due to a manufacturing issue and can also make some noise when the Carriage moves.



## 4. Firmware

### Localization issues

- a. Scanning complete message

**Question:** When a scan is complete the final screen—“scan successful”—is not localized.

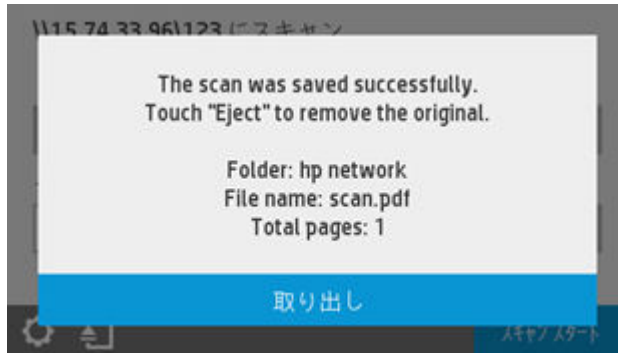

**Answer:** This has already been fixed in FW release VR1.5 (FW1548A).

- b. Print from USB settings

**Question:** A setting in Print from USB is not localized.



**Question:** Print From USB ► Resize ► Fit to Loaded Paper is not localized.

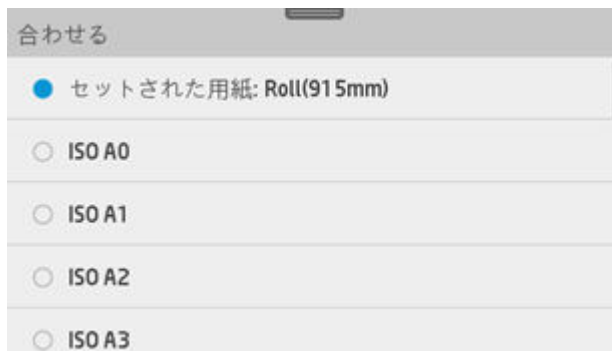

**Answer:** It has already been fixed in FW release VR1.5 (FW1548A).

c. Copy settings

**Question:** “Custom” is not localized.

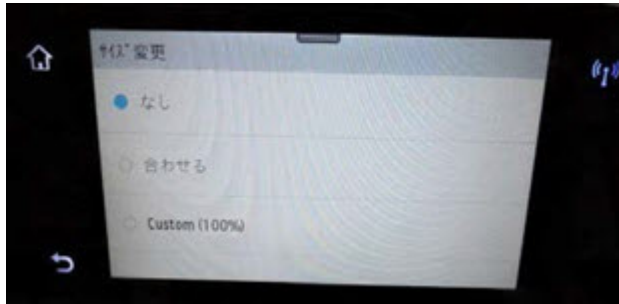

**Answer:** It has already been fixed in FW release VR1.5 (FW1548A).

### Long plot in VR2.1

**Question:** Printer (T830 MFP) will not scan beyond 2.7 m in length.

**Answer:** This is the expected performance for every mode and resolution. They all scan 2.7 m. In case you want to scan longer plots, there will be a “Long plot scan” mode available in the firmware to be released at the end of Mar’16. You will be able to scan up to 8 meters (initially it was only 7.2 m).

### Touch Panel screen freezes at Load A4 screen (also at other screens) - Workaround

**Question:** How do I proceed when the printer is hung up when loading paper or at the HP Logo screen?

**Answer:** Perform an OOB reset to recover printer from the unstable status. Follow the next steps:

1. Insert a sheet of paper in the multisheet tray.

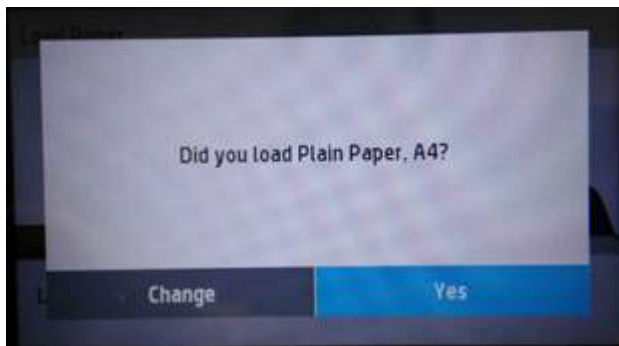

2. Select **Change**.

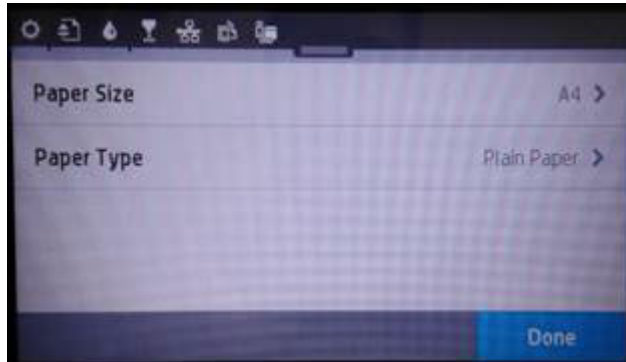

3. Here, slide down the top menu and press **Info**.



4. Press **HP Designjet T730/T830 (printer name)** and the printer will go back to screen 2.
5. This time select **Done**.
6. Click on the **Home** icon
7. Enter the Extended Diagnostic Menu. Press **HOME + BACK + HOME + HOME**.
8. Go to the Reset menu and perform an **OOBE reset**.

## File format supported printing from USB

**Question:** What are the file formats supported to print from USB host?

**Answer:** Formats supported are: TIFF, JPEG and HP-GL/2.

- In firmware version 1548A and previous when trying to print wrong formats files, a bluescreen may appear. Reboot the unit and instruct the Customer not to print unsupported files.
- In the next firmware version VR2.1 the wrong file formats will not be shown on the Touch Panel.

## 5. Software and Drivers

### Vectorworks11: Collate function

**Question:** Vectorworks 2011 has an issue with the collate function as it works in the opposite way it was intended with any vendor driver (not only Candela, but all HP drivers, OCE and Canon drivers).



**Answer:** This bug was solved in Vectorworks 2012.

## Bluebeam markups

**Question:** Problems printing PDF documents with markups (they are not printed, missing objects, nonsensical characters).

**Answer:** Update Bluebeam Revu version 2015.6. If not possible, save the PDF with the markups as a Bluebeam PDF and send the newly created PDF to print.

## Windows XP and Vista: Driver installer does not work

**Question:** Windows XP or Vista is not supported by the driver installer.

**Answer:** Windows XP and Vista is no longer supported. Customers may install the driver using the discrete driver (.inf file), but it is not supported by HP.

## Driver V4 fixes

**Question:** What fixes are included in driver v4 (the latest release)?

**Answer:** v4 adds support for the following products:

- HP DesignJet T830 Multifunction Printer series
- HP DesignJet T730 Printer series
- HP DesignJet T930 Printer series
- HP DesignJet T1530 Printer series
- HP DesignJet T2530 Multifunction Printer series
- HP Designjet T120 ePrinter series
- HP Designjet T520 ePrinter series

## Driver v3: Supported OS

**Question:** What Operating Systems are supported by driver v3?

**Answer:** Microsoft Windows Server 2008 W32, Microsoft Windows 7 (32-bit), Microsoft Windows 8 (32-bit), Microsoft Windows 8.1 (32-bit), Microsoft Windows 10 (32-bit), Microsoft Windows Server 2008 x64, Microsoft Windows 7 (64-bit), Microsoft Windows Server 2008 R2, Microsoft Windows 8 (64-bit), Microsoft Windows Server 2012 x64, Microsoft Windows 8.1 (64-bit), Microsoft Windows Server 2012 R2, Microsoft Windows 10 (64-bit), Mac OS X 10.8, Mac OS X 10.9, Mac OS X 10.10 and Mac OS X 10.11.

## Printing complex PDFs from Adobe applications does not work

**Question:** Complex files cannot be printed with the HP-GL/2 driver using Adobe apps due to processing issues.

**Answer:** Complex files generate big HP-GL/2 print files and the job cannot be printed due to memory limitations. There are several workarounds:

- Use another App to print these jobs.
- Select the “print job as bitmap” option.
- In the future there will be a PCL driver to simplify processing.

## Jobs rotated unexpectedly

**Question:** Jobs are rotated, although they still fit on the roll that is loaded.

**Answer:** Some rolls can have different width measures. The printer uses the Line sensor to measure the roll and provides you with the width of the roll. If the roll is a non-standard width, the printer will measure the exact width (e.g. 35.90” instead of 36”). So if you send a 36” x 24” job, it doesn’t fit onto the 35.90” roll and it will be rotated. In order to avoid this issue you can use paper with a valid width and/or uncheck the “autorotate” feature.

## Windows Photo Viewer printing issues

**Question:** Printing issues like blank printouts and missing objects when printing from Windows Photo Viewer.

**Answer:**

1. There is no preview for print settings. This issue is due to the Windows Photo Viewer app when selecting some page sizes. Jobs are printed with good quality.
2. When printing specific resized files (e.g. 150% of the actual size) a blank area is shown in the middle of the printout. The troubleshooting recommendation is to use another app to print these jobs.

## Recommended maximum printing length

**Question:** What is the recommended max plot length for printing?

**Answer:** The maximum plot length is defined by the driver.

- HP-GL/2 (included in installer) driver: 91 meters.
- HP DesignJet Raster driver for Windows Modern Apps: 3.2 meters.
- Mac HP DesignJet Raster Driver: 91 meters.

## Multiple copy selection does not work in AutoCAD 2013

**Question:** When selecting multiple copies in AutoCAD 2013, the printer only prints one job.

**Answer:** This is an AutoCAD issue. The “copies” setting is not synchronized with the HP driver and thus “copies” information is not sent to the printer. In order to select several copies, you must select the number of copies in the driver interface, not in the app interface.

## Issues printing from Windows Class Driver

**Question:** Several issues may appear when printing from Windows Class Driver.

**Answer:** The Windows Class Driver is an old driver, existing previously to the T730/T830 release, so the performance of this driver is not optimized for this printer. It is not recommended to use this driver; you must install the latest driver version available on the HP website.

## 6. Network

### WiFi Direct - Win8: “Limited connectivity”

**Question:** Windows 8/8.1/10 OS is showing connection limited when connected to the printer through Direct Wi-Fi.



**Answer:** Not a connectivity issue. Windows shows this message because it is trying to connect the device to the internet using the Wi-Fi Direct connection, which is not possible. Wi-Fi direct is intended to connect the printer with several devices (up to 5) but it is not a hotspot for connecting them to internet.

### IP static in some units

**Question:** Unit does not connect to LAN and IP address is 192.xx.xx.xxx.

**Answer:** Some units did not undergo the right process in the manufacturing line and left the factory with their IP set to static. Workaround: Change IP setting to “automatic” in Front Panel.

- Potentially affected population: S/Ns starting with CN59xxxxxxx, CN5Axxxxxxx and CN5Bxxxxxxx.

### Permanently disabling Wireless connectivity on T730s/T830s

**Question:** Can we remove the WiFi board from the MainPCA if we want to disable WiFi?

**Answer:** Yes, unit will work OK:

- The WiFi module can be physically removed from the Main PCA. Unit will work normally but WiFi will not work, evidently.
- All WiFi settings/options in the Front Panel and EWS will be shown but will not be functional.
- The EWS Administrator can hide the WiFi options present in the Front Panel so normal users do not see them.
-  **IMPORTANT:** In case of a repair, the MPCA SV kit contains an MPCA with the WiFi module, so WiFi would be enabled again.

