



LaserJet Pro M402, M403 LaserJet Pro M426, M427

Repair Manual



M402d
M402n
M402dn
M402dw
M403n
M403d
M403dn
M403dw



M426dw
M426fdn
M426fdw
M427dw
M427fdn
M427fdw



www.hp.com/support/ljM402
www.hp.com/support/ljM403
www.hp.com/support/ljM426MFP
www.hp.com/support/ljM427MFP
For printer theory and troubleshooting information, see the Troubleshooting Manual.



LaserJet Pro M402, M403 and LaserJet Pro M426, M427

Repair Manual

Copyright and License

© Copyright 2015 HP Development Company, L.P.

Reproduction, adaptation, or translation without prior written permission is prohibited, except as allowed under the copyright laws.

The information contained herein is subject to change without notice.

The only warranties for HP products and services are set forth in the express warranty statements accompanying such products and services. Nothing herein should be construed as constituting an additional warranty. HP shall not be liable for technical or editorial errors or omissions contained herein.

Edition 1, 9/2015

Conventions used in this guide

 **TIP:** Helpful hints or shortcuts.

Reinstallation tip: Reinstallation helpful hints, shortcuts, or considerations.

 **NOTE:** Information that explains a concept or how to complete a task.

 **IMPORTANT:** Information that help the user to avoid potential printer error conditions.

 **CAUTION:** Procedures that the user must follow to avoid losing data or damaging the printer.

 **WARNING!** Procedures that the user must follow to avoid personal injury, catastrophic loss of data, or extensive damage to the printer.

For additional service and support information

HP service personnel, go to the Service Access Work Bench (SAW) at <http://h41302.www4.hp.com/km/saw/home.do>.

Channel partners, go to HP Channel Services Network (CNS) at <https://h30125.www3.hp.com/hpcsn>.

At these locations, find information on the following topics:

- Install and configure
- Printer specifications
- Up-to-date control panel message (CPMD) troubleshooting
- Solutions for printer issues and emerging issues
- Remove and replace part instructions and videos
- Service advisories
- Warranty and regulatory information

To access HP PartSurfer information from any mobile device, go to <http://partsurfermobile.hp.com/> or scan the Quick Response (QR) code below.



Table of contents

1 Removal and replacement	1
For additional service and support	2
Removal and replacement strategy	3
Introduction	3
Considerations during removal and replacement	3
Electrostatic discharge	4
Required tools	4
Fasteners used in this printer	5
Service approach	6
Before performing service	6
After performing service	6
Post-service test	6
Print-quality test	6
Removal and replacement procedures	7
Customer self-repair (CSR) A parts and assemblies	7
RL2-0656-000CN multipurpose tray roller	8
Introduction	8
Step 1: Remove the roller	8
Step 2: Unpack the replacement assembly	10
Step 3: Install the roller	11
RM2-5392-000CN 250-sheet paper input tray	13
Introduction	13
Step 1: Remove Tray 2	13
Step 2: Unpack the replacement assembly	14
Step 3: Install Tray 2	14
RM2-5413-000CN optional Tray 3	16
Introduction	16
Step 1: Remove optional Tray 3	16
Step 2: Unpack the replacement assembly	17
Step 3: Install optional Tray 3	18
RM2-5452-000CN Tray 2 paper pickup roller assembly	20
Introduction	20

Step 1: Remove Tray 2	20
Step 2: Remove the pickup roller assembly (Tray 2)	21
Step 3: Unpack the replacement assembly	23
Step 4: Install the pickup roller assembly (Tray 2)	24
Step 5: Install Tray 2	25
RM2-5741-000CN optional Tray 3 paper pickup roller assembly	27
Introduction	27
Step 1: Remove optional Tray 3	27
Step 2: Remove the paper pickup roller assembly (optional Tray 3)	28
Step 3: Unpack the replacement assembly	30
Step 4: Install the paper pickup roller assembly (optional Tray 3)	31
Step 5: Install optional Tray 3	32
RM2-5397-000CN Tray 2 separation roller assembly	34
Introduction	34
Step 1: Remove Tray 2	34
Step 2: Remove the separation pad roller assembly (Tray 2)	35
Step 3: Unpack the replacement assembly	36
Step 4: Install the separation pad roller assembly (Tray 2)	36
Step 5: Install Tray 2	37
RM2-5745-000CN optional Tray 3 separation roller assembly	39
Introduction	39
Step 1: Remove Tray 3	39
Step 2: Remove the separation roller assembly (optional Tray 3)	40
Step 3: Unpack the replacement assembly	41
Step 4: Install the separation roller assembly (optional Tray 3)	42
Step 5: Install Tray 3	43
Removal and replacement: External panels, covers, and doors	45
Removal and replacement: Damper sheets	46
Introduction	46
Step 1: Remove the damper sheets	46
Step 2: Unpack the replacement assembly	47
Step 3: Install the damper sheets	47
Removal and replacement: Rear USB cover	46
Introduction	49
Step 1: Remove the rear USB cover	49
Step 2: Unpack the replacement assembly	50
Step 3: Install the rear USB cover	51
Removal and replacement: Support shaft	53
Introduction	53
Step 1: Remove the support shaft	53
Step 2: Unpack the replacement assembly	54

Step 3: Install the support shaft	55
Removal and replacement: Cartridge door assembly	57
Introduction	57
Step 1: Remove the cartridge door assembly	57
Step 2: Unpack the replacement assembly	60
Step 3: Install the cartridge door assembly	61
Removal and replacement: Pressure-release link	64
Introduction	64
Step 1: Remove the cartridge door assembly	64
Step 2: Remove the pressure-release link	67
Step 3: Unpack the replacement assembly	68
Step 4: Install the pressure-release link	68
Step 5: Install the cartridge door assembly	69
Removal and replacement: Left cover	73
Introduction	73
Step 1: Remove the rear USB cover	74
Step 2: Remove the rear network cover (M402d and M403d)	75
Step 3: Remove Tray 2	75
Step 4: Remove the cartridge door assembly	76
Step 5: Remove the left cover	78
Step 6: Unpack the replacement assembly	80
Step 7: Install the left cover	80
Step 8: Install the cartridge door assembly	82
Step 9: Install Tray 2	85
Step 10: Install the rear network cover (M402d and M403d)	85
Step 11: Install the rear USB cover	85
Removal and replacement: Right cover	87
Introduction	87
Step 1: Remove Tray 2	87
Step 2: Remove the cartridge door assembly	88
Step 3: Remove the right cover	90
Step 4: Unpack the replacement assembly	91
Step 5: Install the right cover	92
Step 6: Install the cartridge door assembly	94
Step 7: Install Tray 2	97
Removal and replacement: Rear door assembly	98
Introduction	98
Step 1: Remove Tray 2	99
Step 2: Remove the cartridge door assembly	99
Step 3: Remove the left cover	102
Step 4: Remove the right cover	103

Step 5: Remove the rear door assembly	104
Step 6: Unpack the replacement assembly	105
Step 7: Install the rear door assembly	106
Step 8: Install the right cover	107
Step 9: Install the left cover	109
Step 10: Install the cartridge door assembly	110
Step 11: Install Tray 2	113
Removal and replacement: Cassette rear cover	114
Introduction	114
Step 1: Remove Tray 2	115
Step 2: Remove the cartridge door assembly	115
Step 3: Remove the left cover	118
Step 4: Remove the right cover	119
Step 5: Remove the rear door assembly	120
Step 6: Remove the cassette rear cover	121
Step 7: Unpack the replacement assembly	123
Step 8: Install the cassette rear door assembly	124
Step 9: Install the rear door assembly	125
Step 10: Install the right cover	125
Step 11: Install the left cover	127
Step 12: Install the cartridge door assembly	128
Step 13: Install Tray 2	132
Removal and replacement: Top cover (M427/M426)	133
Introduction	133
Step 1: Remove Tray 2	134
Step 2: Remove the cartridge door assembly	134
Step 3: Remove the left cover	137
Step 4: Remove the right cover	138
Step 5: Remove the integrated scanner assembly (M427/M426)	140
Step 6: Remove the control panel (M427/M426)	144
Step 7: Remove the top cover (M427/M426)	148
Step 8: Unpack the replacement assembly	149
Step 9: Remove the cable guide (M427/M426)	150
Step 10: Install the cable guide (M427/M426)	151
Step 11: Install the top cover (M427/M426)	153
Step 12: Install the control panel (M427/M426)	155
Step 13: Install the integrated scanner assembly (M427/M246)	159
Step 14: Install the right cover	164
Step 15: Install the left cover	166
Step 16: Install the cartridge door assembly	167
Step 17: Install Tray 2	171

Removal and replacement: Cable guide (M427/M426)	172
Introduction	172
Step 1: Remove Tray 2	173
Step 2: Remove the cartridge door assembly	173
Step 3: Remove the left cover	176
Step 4: Remove the right cover	177
Step 5: Remove the control panel (M427/M426)	178
Step 6: Remove the integrated scanner assembly (M427/M246)	182
Step 7: Remove the top cover (M427/M426)	187
Step 8: Remove the cable guide (M427/M426)	188
Step 9: Unpack the replacement assembly	190
Step 10: Install the cable guide (M427/M426)	190
Step 11: install the top cover (M427/M426)	192
Step 12: Install the integrated scanner assembly (M427/M246)	194
Step 13: Install the control panel (M427/M426)	199
Step 14: Install the right cover	203
Step 15: Install the left cover	205
Step 16: Install the cartridge door assembly	206
Step 17: Install Tray 2	210
Removal and replacement: Top cover (M403/M402)	211
Introduction	211
Step 1: Remove Tray 2	212
Step 2: Remove the cartridge door assembly	212
Step 3: Remove the left cover	215
Step 4: Remove the right cover	216
Step 5: Remove the top cover (M403/M402)	217
Step 6: Remove the 2-line LCD operator and indication covers (M403/ M402)	219
Step 7: Unpack the replacement assembly	220
Step 8: Install the 2-line LCD operator and indication covers (M403/ M402)	221
Step 9: Install the top cover (M403/M402)	222
Step 10: Install the right cover	224
Step 11: Install the left cover	226
Step 12: Install the cartridge door assembly	227
Step 13: Install Tray 2	231
Removal and replacement: 2-line LCD operator and indication covers (M403/ M402)	232
Introduction	232
Step 1: Remove Tray 2	233
Step 2: Remove the cartridge door assembly	233

Step 3: Remove the left cover	236
Step 4: Remove the right cover	237
Step 5: Remove the top cover (M403/M402)	238
Step 6: Remove the 2-line LCD operator and indication covers (M403/ M402)	240
Step 7: Unpack the replacement assembly	241
Step 8: Install the 2-line LCD operator and indication covers (M403/ M402)	242
Step 9: Install the top cover (M403/M402)	243
Step 10: Install the right cover	245
Step 11: Install the left cover	247
Step 12: Install the cartridge door assembly	248
Step 13: Install Tray 2	252
Removal and replacement: Paper delivery tray (output bin)	253
Introduction	253
Step 1: Remove Tray 2	254
Step 2: Remove the cartridge door assembly	255
Step 3: Remove the left cover	257
Step 4: Remove the right cover	258
Step 5: Remove the integrated scanner assembly (M427/M246)	259
Step 6: Remove the control panel (M427/M246)	264
Step 7: Remove the top cover (M427/M426)	268
Step 8: Remove the top cover (M403/M402)	269
Step 9: Remove the paper delivery tray (output bin)	271
Step 10: Unpack the replacement assembly	272
Step 11: Install the paper delivery tray (output bin)	272
Step 12: Install the top cover (M403/M402)	273
Step 13: Install the top cover (M427/M426)	275
Step 14: Install the control panel (M427/M246)	277
Step 15: Install the integrated scanner assembly (M427/M246)	281
Step 16: Install the right cover	286
Step 17: Install the left cover	288
Step 18: Install the cartridge door assembly	289
Step 19: Install Tray 2	293
Removal and replacement: Integrated scanner assembly (M427/M426)	294
Introduction	294
Step 1: Remove Tray 2	295
Step 2: Remove the cartridge door assembly	295
Step 3: Remove the left cover	298
Step 4: Remove the ISA (M427/M426)	299
Step 5: Unpack the replacement assembly	304

Step 6: Install the ISA (M427/M426)	305
Step 7: Install the left cover	310
Step 8: Install the cartridge door assembly	311
Step 9: Install Tray 2	315
Removal and replacement: ISA lift assembly and slider pin (M427/M426)	294
Introduction	316
Step 1: Remove the slider pin (M427/M426)	317
Step 2: Remove the ISA lift assembly (M427/M426)	317
Step 3: Unpack the replacement assembly	319
Step 4: Install the ISA lift assembly (M427/M426)	320
Step 5: Install the slider pin (M427/M426)	322
Removal and replacement: Internal parts and assemblies	324
Removal and replacement: Fuser	325
Introduction	325
Step 1: Remove Tray 2	326
Step 2: Remove the cartridge door assembly	326
Step 3: Remove the left cover	329
Step 4: Remove the right cover	330
Step 5: Remove the rear door assembly	331
Step 6: Remove the fuser	332
Step 7: Unpack the replacement assembly	335
Step 8: Install the fuser	336
Step 9: Install the rear door assembly	339
Step 10: Install the right cover	340
Step 11: Install the left cover	342
Step 12: Install the cartridge door assembly	343
Step 13: Install Tray 2	346
Removal and replacement: Registration assembly	347
Introduction	347
Step 1: Remove Tray 2	348
Step 2: Remove the cartridge door assembly	349
Step 3: Remove the left cover	351
Step 4: Remove the right cover	353
Step 5: Remove the rear door assembly	354
Step 6: Remove the integrated scanner assembly (M427/M246)	355
Step 7: Remove the control panel (M427/M426)	360
Step 8: Remove the top cover (M427/M426)	364
Step 9: Remove the top cover (M403/M402)	365
Step 10: Remove the paper delivery tray (output bin)	366
Step 11: Remove the fuser	367
Step 12: Remove the registration assembly	370

Step 13: Unpack the replacement assembly	373
Step 14: Install the registration assembly	374
Step 15: Install the fuser	376
Step 16: Install the paper delivery tray (output bin)	379
Step 17: Install the top cover (M403/M402)	380
Step 18: Install the top cover (M427/M426)	382
Step 19: Install the control panel (M427/M246)	384
Step 20: Install the integrated scanner assembly (M427/M246)	388
Step 21: Install the rear door assembly	393
Step 22: Install the right cover	394
Step 23: Install the left cover	396
Step 24: Install the cartridge door assembly	397
Step 25: Install Install Tray 2	401
Removal and replacement: Main motor (M1)	402
Introduction	402
Step 1: Remove Tray 2	403
Step 2: Remove the cartridge door assembly	403
Step 3: Remove the right cover	405
Step 4: Remove the main motor (M1)	406
Step 5: Unpack the replacement assembly	407
Step 6: Install the main motor (M1)	407
Step 7: Install the right cover	408
Step 8: Install the cartridge door assembly	410
Step 9: Install Tray 2	413
Removal and replacement: Power switch printed circuit assembly	414
Introduction	414
Step 1: Remove Tray 2	415
Step 2: Remove the cartridge door assembly	415
Step 3: Remove the right cover	418
Step 4: Remove the power switch PCA	419
Step 5: Unpack the replacement assembly	421
Step 6: Install the power switch PCA	422
Step 7: Install the right cover	423
Step 8: Install the cartridge door assembly	425
Step 9: Install Tray 2	428
Removal and replacement: Fax PCA (M427/M426)	429
Introduction	429
Step 1: Remove Tray 2	430
Step 2: Remove the cartridge door assembly	430
Step 3: Remove the left cover	433
Step 4: Remove the fax PCA (M427/M426)	434

Step 5: Unpack the replacement assembly	435
Step 6: Install the fax PCA (M427/M426)	436
Step 7: Install the left cover	437
Step 8: Install the cartridge door assembly	438
Step 9: Install Tray 2	442
Removal and replacement: Walkup USB PCA (M427/M426)	443
Introduction	443
Step 1: Remove Tray 2	444
Step 2: Remove the cartridge door assembly	444
Step 3: Remove the left cover	447
Step 4: Remove the fax PCA	448
Step 5: Remove the walkup USB PCA (M427/M426)	449
Step 6: Unpack the replacement assembly	451
Step 7: Install the walkup USB PCA (M427/M426)	451
Step 8: Install the fax PCA	453
Step 9: Install the left cover	454
Step 10: Install the cartridge door assembly	455
Step 9: Install Tray 2	459
Removal and replacement: Wireless PCA	460
Introduction	460
Step 1: Remove Tray 2	461
Step 2: Remove the cartridge door assembly	461
Step 3: Remove the left cover	464
Step 4: Remove the wireless PCA	465
Step 5: Unpack the replacement assembly	466
Step 6: Install the wireless PCA	467
Step 7: Install the left cover	468
Step 8: Install the cartridge door assembly	469
Step 9: Install Tray 2	473
Removal and replacement: Formatter PCA	474
Introduction	474
Step 1: Remove Tray 2	475
Step 2: Remove the cartridge door assembly	475
Step 3: Remove the left cover	478
Step 4: Remove the fax PCA	479
Step 5: Remove the wireless PCA	480
Step 6: Remove the formatter PCA	481
Step 7: Unpack the replacement assembly	483
Step 8: Install the formatter PCA	483
Step 9: Install the wireless PCA	485
Step 10: Install the fax PCA	486

Step 11: Install the left cover	487
Step 12: Install the cartridge door assembly	488
Step 13: Install Tray 2	492
Removal and replacement: Fan (FM1)	493
Introduction	493
Step 1: Remove Tray 2	494
Step 2: Remove the cartridge door assembly	494
Step 3: Remove the left cover	496
Step 4: Remove the fan (FM1)	498
Step 5: Unpack the replacement assembly	499
Step 6: Install the fan (FM1)	500
Step 7: Install the left cover	501
Step 8: Install the cartridge door assembly	502
Step 9: Install Tray 2	506
Removal and replacement: Fan holder (FM1)	507
Introduction	507
Step 1: Remove Tray 2	508
Step 2: Remove the cartridge door assembly	508
Step 3: Remove the left cover	511
Step 4: Remove the fan (FM1)	512
Step 5: Remove the fan holder (FM1)	514
Step 6: Unpack the replacement assembly	516
Step 7: Install the fan holder (FM1)	517
Step 8: Install the fan (FM1)	518
Step 9: Install the left cover	519
Step 10: Install the cartridge door assembly	521
Step 11: Install Tray 2	524
Removal and replacement: Laser scanner assembly	525
Introduction	525
Step 1: Remove Tray 2	526
Step 2: Remove the cartridge door assembly	526
Step 3: Remove the left cover	529
Step 4: Remove the right cover	530
Step 5: Remove the integrated scanner assembly (M427/M246)	531
Step 6: Remove the control panel (M427/M246)	536
Step 7: Remove the top cover (M427/M426)	540
Step 8: Remove the top cover (M403/M402)	541
Step 9: Remove the paper delivery tray (output bin)	543
Step 10: Remove the laser scanner assembly	544
Step 11: Unpack the replacement assembly	544
Step 12: Install the laser scanner assembly	545

Step 13: Install the paper delivery tray (output bin)	546
Step 14: Install the top cover (M403/M402)	546
Step 15: Install the top cover (M427/M426)	548
Step 16: Install the control panel (M427/M246)	551
Step 17: Install the integrated scanner assembly (M427/M246)	555
Step 18: Install the right cover	560
Step 19: Install the left cover	562
Step 20: Install the cartridge door assembly	563
Step 21: Install Tray 2	566
Removal and replacement: Sheet-metal formatter bracket and formatter PCA	567
Step 1: Remove Tray 2	567
Step 2: Remove the cartridge door assembly	568
Step 3: Remove the left cover	570
Step 4: Remove the right cover	572
Step 5: Remove the integrated scanner assembly (M427/M246)	573
Step 6: Remove the control panel (M427/M246)	578
Step 7: Remove the top cover (M427/M426)	582
Step 8: Remove the top cover (M403/M402)	583
Step 9: Remove the sheet-metal formatter bracket and formatter PCA ..	584
Step 10: Install the sheet-metal formatter bracket and formatter PCA ...	587
Step 11: Install the top cover (M403/M402)	589
Step 12: Install the top cover (M427/M426)	590
Step 13: Install the control panel (M427/M246)	593
Step 14: Install the integrated scanner assembly (M427/M246)	597
Step 15: Install the right cover	602
Step 16: Install the left cover	604
Step 17: Install the cartridge door assembly	605
Step 18: Install Tray 2	608
Removal and replacement: NFC FFC	609
Introduction	609
Step 1: Remove Tray 2	610
Step 2: Remove the cartridge door assembly	611
Step 3: Remove the left cover	613
Step 4: Remove the right cover	615
Step 5: Remove the integrated scanner assembly (M427/M246)	616
Step 6: Remove the control panel (M427/M246)	621
Step 7: Remove the top cover (M427/M426)	625
Step 8: Remove the NFC PCA cover (M427/M426)	626
Step 9: Remove the top cover (M403/M402)	627
Step 10: Remove the paper delivery tray (output bin)	628
Step 11: Remove the NFC PCA	629

Step 12: Remove the NFC FFC	629
Step 13: Unpack the replacement assembly	631
Step 14: Install the NFC FFC	631
Step 15: Install the NFC PCA	633
Step 16: Install the paper delivery tray (output bin)	635
Step 17: Install the top cover (M403/M402)	635
Step 18: Install the NFC PCA cover (M427/M426)	637
Step 19: Install the top cover (M427/M426)	638
Step 20: Install the control panel (M427/M246)	640
Step 21: Install the integrated scanner assembly (M427/M246)	644
Step 22: Install the right cover	649
Step 23: Install the left cover	651
Step 24: Install the cartridge door assembly	652
Step 25: Install Tray 2	655
Removal and replacement: Control panel FFC, (M403/M402)	656
Introduction	656
Step 1: Remove Tray 2	657
Step 2: Remove the cartridge door assembly	657
Step 3: Remove the left cover	660
Step 4: Remove the right cover	661
Step 5: Remove the top cover (M403/M402)	662
Step 6: Remove the paper delivery tray (output bin)	664
Step 7: Remove the control panel FFC	665
Step 8: Unpack the replacement assembly	666
Step 9: Install the control panel FFC	666
Step 10: Install the paper delivery tray (output bin)	668
Step 11: Install the top cover (M403/M402)	668
Step 12: Install the right cover	670
Step 13: Install the left cover	672
Step 14: Install the cartridge door assembly	673
Step 15: Install Tray 2	677
Removal and replacement: Formatter FFC	678
Introduction	678
Step 1: Remove Tray 2	679
Step 2: Remove the cartridge door assembly	680
Step 3: Remove the left cover	682
Step 4: Remove the right cover	683
Step 5: Remove the integrated scanner assembly (M427/M246)	684
Step 6: Remove the control panel (M427/M246)	689
Step 7: Remove the top cover (M427/M426)	693
Step 8: Remove the top cover (M403/M402)	694

Step 9: Remove the sheet-metal formatter bracket and formatter PCA ..	696
Step 10: Remove the formatter FFC	698
Step 11: Unpack the replacement assembly	699
Step 12: Install the formatter FFC	700
Step 13: Install the sheet-metal formatter bracket and formatter PCA ...	701
Step 14: Install the top cover (M403/M402)	703
Step 15: Install the top cover (M427/M426)	705
Step 16: Install the control panel (M427/M246)	708
Step 17: Install the integrated scanner assembly (M427/M246)	712
Step 18: Install the right cover	717
Step 19: Install the left cover	719
Step 20: Install the cartridge door assembly	720
Step 21: Install Tray 2	723
Removal and replacement: DC controller	724
Introduction	724
Step 1: Remove Tray 2	725
Step 2: Remove the cartridge door assembly	726
Step 3: Remove the left cover	728
Step 4: Remove the right cover	730
Step 5: Remove the rear door assembly	731
Step 6: Remove the integrated scanner assembly (M427/M246)	732
Step 7: Remove the control panel (M427/M246)	737
Step 8: Remove the top cover (M427/M426)	741
Step 9: Remove the top cover (M403/M402)	742
Step 10: Remove the paper delivery tray (output bin)	743
Step 11: Remove the sheet-metal formatter bracket and formatter	744
Step 12: Remove the DC controller	746
Step 13: Unpack the replacement assembly	748
Step 14: Install the DC controller	749
Step 15: Install the sheet-metal formatter bracket and formatter	751
Step 16: Install the paper delivery tray (output bin)	754
Step 17: Install the top cover (M403/M402)	754
Step 18: Install the top cover (M427/M426)	756
Step 19: Install the control panel (M427/M246)	758
Step 20: Install the integrated scanner assembly (M427/M246)	762
Step 21: Install the rear door assembly	767
Step 22: Install the right cover	768
Step 23: Install the left cover	770
Step 24: Install the cartridge door assembly	771
Step 25: Install Tray 2	775
Removal and replacement: Tag-cable assembly (toner-cartridge memory)	776

Introduction	776
Step 1: Remove Tray 2	777
Step 2: Remove the cartridge door assembly	778
Step 3: Remove the left cover	780
Step 4: Remove the right cover	781
Step 5: Remove the integrated scanner assembly (M427/M246)	782
Step 6: Remove the control panel (M427/M246)	787
Step 7: Remove the top cover (M427/M426)	791
Step 8: Remove the top cover (M403/M402)	792
Step 9: Remove the paper delivery tray (output bin)	794
Step 10: Remove the sheet-metal formatter bracket and formatter PCA	795
Step 11: Remove the tag-cable assembly (toner-cartridge memory)	797
Step 12: Unpack the replacement assembly	798
Step 13: Install the tag-cable assembly (toner-cartridge memory)	799
Step 14: Install the sheet-metal formatter bracket and formatter PCA ...	800
Step 15: Install the paper delivery tray (output bin)	803
Step 16: Install the top cover (M403/M402)	803
Step 17: Install the top cover (M427/M426)	805
Step 18: Install the control panel (M427/M246)	807
Step 19: Install the integrated scanner assembly (M427/M246)	811
Step 20: Install the right cover	816
Step 21: Install the left cover	818
Step 22: Install the cartridge door assembly	819
Step 23: Install Tray 2	823
Removal and replacement: Connecting PCA	824
Introduction	824
Step 1: Remove Tray 2	825
Step 2: Remove the cartridge door assembly	826
Step 3: Remove the left cover	828
Step 4: Remove the right cover	830
Step 5: Remove the integrated scanner assembly (M427/M246)	831
Step 6: Remove the control panel (M427/M246)	836
Step 7: Remove the top cover (M427/M426)	840
Step 8: Remove the top cover (M403/M402)	841
Step 9: Remove the paper delivery tray (output bin)	842
Step 10: Remove the sheet-metal formatter bracket and formatter PCA	843
Step 11: Remove the connecting PCA	845
Step 12: Unpack the replacement assembly	847
Step 13: Install the connecting PCA	847

Step 14: Install the sheet-metal formatter bracket and formatter PCA ...	849
Step 15: Install the paper delivery tray (output bin)	851
Step 16: Install the top cover (M403/M402)	852
Step 17: Install the top cover (M427/M426)	854
Step 18: Install the control panel (M427/M246)	856
Step 19: Install the integrated scanner assembly (M427/M246)	860
Step 20: Install the right cover	865
Step 21: Install the left cover	867
Step 22: Install the cartridge door assembly	868
Step 23: Install Tray 2	872
Removal and replacement: Laser scanner FFC	873
Introduction	873
Step 1: Remove Tray 2	874
Step 2: Remove the cartridge door assembly	875
Step 3: Remove the left cover	877
Step 4: Remove the right cover	879
Step 5: Remove the integrated scanner assembly (M427/M246)	880
Step 6: Remove the control panel (M427/M246)	885
Step 7: Remove the top cover (M427/M426)	889
Step 8: Remove the top cover (M403/M402)	890
Step 9: Remove the paper delivery tray (output bin)	891
Step 10: Remove the sheet-metal formatter bracket and formatter PCA	892
Step 11: Remove the tag-cable assembly	894
Step 12: Remove the laser scanner FFC	896
Step 13: Unpack the replacement assembly	898
Step 14: Install the laser scanner FFC	899
Step 15: Install the tag-cable assembly	901
Step 16: Install the sheet-metal formatter bracket and formatter PCA ...	903
Step 17: Install the paper delivery tray (output bin)	905
Step 18: Install the top cover (M403/M402)	906
Step 19: Install the top cover (M427/M426)	908
Step 20: Install the control panel (M427/M246)	910
Step 21: Install the integrated scanner assembly (M427/M246)	914
Step 22: Install the right cover	919
Step 23: Install the left cover	921
Step 24: Install the cartridge door assembly	922
Step 25: Install Tray 2	926
Removal and replacement: High-voltage power supply	927
Introduction	927
Step 1: Remove Tray 2	928

Step 2: Remove the cartridge door assembly	929
Step 3: Remove the left cover	931
Step 4: Remove the right cover	932
Step 5: Remove the integrated scanner assembly (M427/M246)	933
Step 6: Remove the control panel (M427/M246)	938
Step 7: Remove the top cover (M427/M426)	942
Step 8: Remove the top cover (M403/M402)	943
Step 9: Remove the paper delivery tray (output bin)	945
Step 10: Remove the sheet-metal formatter bracket and formatter PCA	946
Step 11: Remove the HVPS	948
Step 12: Unpack the replacement assembly	950
Step 13: Install the HVPS	951
Step 14: Install the sheet-metal formatter bracket and formatter PCA ...	953
Step 15: Install the paper delivery tray (output bin)	956
Step 16: Install the top cover (M403/M402)	956
Step 17: Install the top cover (M427/M426)	958
Step 18: Install the control panel (M427/M246)	960
Step 19: Install the integrated scanner assembly (M427/M246)	964
Step 20: Install the right cover	969
Step 21: Install the left cover	971
Step 22: Install the cartridge door assembly	972
Step 23: Install Tray 2	976
Removal and replacement: Low-voltage power supply	977
Introduction	977
Step 1: Remove Tray 2	978
Step 2: Remove the cartridge door assembly	979
Step 3: Remove the left cover	981
Step 4: Remove the right cover	983
Step 5: Remove the integrated scanner assembly (M427/M246)	984
Step 6: Remove the control panel (M427/M246)	989
Step 7: Remove the top cover (M427/M426)	993
Step 8: Remove the top cover (M403/M402)	994
Step 9: Remove the paper delivery tray (output bin)	995
Step 10: Remove the fan (FM1)	996
Step 11: Remove the sheet-metal formatter bracket and formatter PCA	997
Step 12: Remove the LVPS	999
Step 13: Unpack the replacement assembly	1003
Step 14: Install the LVPS	1004
Step 15: Install the sheet-metal formatter bracket and formatter PCA .	1008

Step 16: Install the fan (FM1)	1010
Step 17: Install the paper delivery tray (output bin)	1011
Step 18: Install the top cover (M403/M402)	1012
Step 19: Install the top cover (M427/M426)	1014
Step 20: Install the control panel (M427/M246)	1016
Step 21: Install the integrated scanner assembly (M427/M246)	1020
Step 23: Install the right cover	1025
Step 24: Install the left cover	519
Step 25: Install the cartridge door assembly	1028
Step 26: Install Tray 2	1032
Removal and replacement: NFC cover (M427/M426)	1033
Introduction	1033
Step 1: Remove Tray 2	1034
Step 2: Remove the cartridge door assembly	1034
Step 3: Remove the left cover	1037
Step 4: Remove the right cover	1038
Step 6: Remove the integrated scanner assembly (M427/M246)	1040
Step 5: Remove the control panel (M427/M426)	1044
Step 7: Remove the top cover (M427/M426)	1048
Step 8: Remove the NFC cover (M427/M426)	1049
Step 9: Unpack the replacement assembly	1050
Step 10: Install the NFC cover (M427/M426)	1050
Step 11: Install the top cover (M427/M426)	1051
Step 12: install the control panel (M427/M426)	1053
Step 12: Install the integrated scanner assembly (M427/M246)	1057
Step 13: Install the right cover	1062
Step 14: Install the left cover	1064
Step 15: Remove the cartridge door assembly	1065
Step 16: Install Tray 2	1069
Removal and replacement: NFC PCA	1070
Introduction	1070
Step 1: Remove Tray 2	1071
Step 2: Remove the cartridge door assembly	1072
Step 3: Remove the left cover	1074
Step 4: Remove the right cover	1075
Step 5: Remove the integrated scanner assembly (M427/M246)	1076
Step 6: Remove the control panel (M427/M426)	1081
Step 7: Remove the top cover (M427/M426)	1085
Step 8: Remove the NFC cover (M427/M426)	1086
Step 9: Remove the top cover (M403/M402)	1087
Step 10: Remove the NFC PCA	1088

Step 11: Unpack the replacement assembly	1089
Step 12: Install the NFC PCA	1090
Step 13: Install the top cover (M403/M402)	1091
Step 14: Install the NFC cover (M427/M426)	1093
Step 15: Install the top cover (M427/M426)	1094
Step 16: Install the control panel (M427/M426)	1096
Step 17: Install the integrated scanner assembly (M427/M246)	1100
Step 18: Install the right cover	1105
Step 19: Install the left cover	1107
Step 20: Remove the cartridge door assembly	1108
Step 21: Install Tray 2	1112
Removal and replacement: Control-panel assembly (M403/M402)	1113
Introduction	1113
Step 1: Remove Tray 2	1114
Step 2: Remove the cartridge door assembly	1114
Step 3: Remove the left cover	1117
Step 4: Remove the right cover	1118
Step 5: Remove the top cover (M403/M402)	1119
Step 6: Remove the paper delivery tray (output bin)	1121
Step 7: Remove the control-panel assembly (M403/M402)	1122
Step 8: Unpack the replacement assembly	1122
Step 9: Install the control-panel assembly (M403/M402)	1123
Step 10: Install the paper delivery tray (output bin)	1124
Step 11: Install the top cover (M403/M402)	1124
Step 12: Install the right cover	1126
Step 13: Install the left cover	1128
Step 14: Install the cartridge door assembly	1129
Step 15: Install Tray 2	1133
Removal and replacement: Control panel (M427/M426) and control panel sub assemblies	1134
Introduction	1134
Step 1: Remove the control panel mount cover (M427/M426)	1135
Step 2: Remove the control panel (M427/M426)	1137
Step 3: Remove the control panel mount base (M427/M426)	1140
Step 4: Remove the control panel mount chassis assembly (M427/ M426)	1141
Step 5: Remove Tray 2	1142
Step 6: Remove the cartridge door assembly	1143
Step 7: Remove the left cover	1145
Step 8: Remove the control panel 22-pin FFC (M427/M426)	1147
Step 9: Unpack the replacement assembly	1149

Step 10: Install the control panel 22-pin FFC (M427/M426)	1150
Step 11: Install the left cover	1152
Step 12: Install the cartridge door assembly	1153
Step 13: Install Tray 2	1157
Step 14: Install the control panel mount chassis assembly (M427/ M426)	1157
Step 15: Install the control panel mount base (M427/M426)	1158
Step 16: Install the control panel (M427/M426)	1159
Step 17: Install the control panel mount cover (M427/M426)	1163
Removal and replacement: Trays	1165
Removal and replacement: Tray 2	1165
RM2-5392-000CN 250-sheet paper input tray	1166
RM2-5452-000CN Tray 2 paper pickup roller assembly	1168
RM2-5397-000CN Tray 2 separation roller assembly	1175
Removal and replacement: Accessories	1180
550-sheet paper feeder	1180
C5F97-69001 optional 550-sheet paper feeder	1181
RM2-5413-000CN optional Tray 3	1186
RM2-5741-000CN optional Tray 3 paper pickup roller assembly	1190
RM2-5745-000CN optional Tray 3 separation roller assembly	1197

2 Parts and diagrams 1203

For additional service and support	1204
Order parts, accessories, and supplies	1205
Ordering	1205
Orderable parts	1205
Supplies	1205
Accessories	1206
Customer self-repair parts	1206
How to use the parts lists and diagrams	1207
Document feeder and image scanner	1208
Main assemblies	1208
Covers, printer base	1210
Covers, M402 and M403	1210
Covers, M426 and M427	1212
Internal components, printer base	1214
Internal components, printer base (1 of 3)	1214
Internal components, printer base (2 of 3)	1216
Internal components, printer base (3 of 3)	1218
550-sheet paper feeder	1220
Covers, 550-sheet paper feeder	1220

Main body, 550-sheet paper feeder	1222
Alphabetical parts list	1224
Numerical parts list	1231

Index	1239
--------------------	-------------

List of tables

Table 2-1	Supplies	1205
Table 2-2	Accessories	1206
Table 2-3	Main assemblies (document feeder and image scanner)	1209
Table 2-4	Covers, M402 and M403	1211
Table 2-5	Covers, M426 and M427	1213
Table 2-6	Internal components, printer base (1 of 3)	1215
Table 2-7	Internal components, printer base (2 of 3)	1217
Table 2-8	Internal components, printer base (3 of 3)	1219
Table 2-9	Covers, 550-sheet paper feeder	1221
Table 2-10	Main body, 550-sheet paper feeder	1223

List of figures

Figure 1-1	Screwdrivers	5
Figure 1-2	Open the toner-cartridge door	9
Figure 1-3	Release two tabs	9
Figure 1-4	Remove the roller	10
Figure 1-5	Recycle and unpack	10
Figure 1-6	Install the roller	11
Figure 1-7	Engage two tabs	11
Figure 1-8	Close the toner-cartridge door	12
Figure 1-9	Remove the tray	14
Figure 1-10	Recycle and unpack	14
Figure 1-11	Install the tray	15
Figure 1-12	Pull the tray out of the printer	17
Figure 1-13	Release and remove the tray	17
Figure 1-14	Recycle and unpack	18
Figure 1-15	Install the tray	18
Figure 1-16	Close the tray	19
Figure 1-17	Remove the tray	21
Figure 1-18	Tilt the printer backward	21
Figure 1-19	Place the printer bottom-side face forward	22
Figure 1-20	Release one tab	22
Figure 1-21	Remove the roller holder	23
Figure 1-22	Recycle and unpack	23
Figure 1-23	Install the roller holder	24
Figure 1-24	Check the tab	24
Figure 1-25	Rotate the printer forward	25
Figure 1-26	Place the printer in the operational position	25
Figure 1-27	Install the tray	26
Figure 1-28	Pull the tray out of the printer	28
Figure 1-29	Release and remove the tray	28
Figure 1-30	Turn the accessory over	29
Figure 1-31	Release the assembly	29
Figure 1-32	Rotate the assembly up	30

Figure 1-33	Remove the assembly	30
Figure 1-34	Recycle and unpack	31
Figure 1-35	Install the roller assembly	31
Figure 1-36	Release the assembly	32
Figure 1-37	Check the installation	32
Figure 1-38	Install the tray	33
Figure 1-39	Close the tray	33
Figure 1-40	Remove the tray	35
Figure 1-41	Release the assembly	35
Figure 1-42	Remove the assembly	36
Figure 1-43	Recycle and unpack	36
Figure 1-44	Install the assembly	37
Figure 1-45	Release the assembly	37
Figure 1-46	Install the tray	38
Figure 1-47	Pull the tray out of the printer	40
Figure 1-48	Release and remove the tray	40
Figure 1-49	Release the assembly	41
Figure 1-50	Remove the assembly	41
Figure 1-51	Recycle and unpack	42
Figure 1-52	Install the assembly	42
Figure 1-53	Release the assembly	43
Figure 1-54	Install the tray	43
Figure 1-55	Close the tray	44
Figure 1-56	Remove the damper sheets	47
Figure 1-57	Recycle and unpack	47
Figure 1-58	Install the damper sheets	48
Figure 1-59	Pull the cover straight off	50
Figure 1-60	Remove the cover	50
Figure 1-61	Recycle and unpack	51
Figure 1-62	Align the tabs on the cover	51
Figure 1-63	Install the cover	52
Figure 1-64	Release the support shaft	54
Figure 1-65	Remove the support shaft	54
Figure 1-66	Recycle and unpack	55
Figure 1-67	Align the hinge	55
Figure 1-68	Install the support shaft	56
Figure 1-69	Release the support shaft	58
Figure 1-70	Remove the guide	58
Figure 1-71	Remove the link arm	59
Figure 1-72	Remove the door	59
Figure 1-73	Release the left-side retainer arm	60

Figure 1-74	Recycle and unpack	60
Figure 1-75	Engage the left-side retainer arm	61
Figure 1-76	Install the door	61
Figure 1-77	Install the pressure-release link	62
Figure 1-78	Install the guide	62
Figure 1-79	Align the hinge	63
Figure 1-80	Install the support shaft	63
Figure 1-81	Release the support shaft	65
Figure 1-82	Remove the guide	65
Figure 1-83	Remove the link arm	66
Figure 1-84	Remove the door	66
Figure 1-85	Release the left-side retainer arm	67
Figure 1-86	Release the pressure-release link	67
Figure 1-87	Remove the pressure-release link	68
Figure 1-88	Recycle and unpack	68
Figure 1-89	Align the keyed portion of the pin	69
Figure 1-90	Install the pressure-release link	69
Figure 1-91	Engage the left-side retainer arm	70
Figure 1-92	Install the door	70
Figure 1-93	Install the pressure-release link	71
Figure 1-94	Install the guide	71
Figure 1-95	Align the hinge	72
Figure 1-96	Install the support shaft	72
Figure 1-97	Pull the cover straight off	74
Figure 1-98	Remove the cover	75
Figure 1-99	Pull the cover straight off	75
Figure 1-100	Remove the tray	76
Figure 1-101	Release the support shaft	76
Figure 1-102	Remove the guide	77
Figure 1-103	Remove the link arm	77
Figure 1-104	Remove the door	78
Figure 1-105	Release the left-side retainer arm	78
Figure 1-106	Remove one screw	79
Figure 1-107	Release two bosses and three tabs	79
Figure 1-108	Remove the cover	80
Figure 1-109	Recycle and unpack	80
Figure 1-110	Install the cover	81
Figure 1-111	Engage three tabs and two bosses	81
Figure 1-112	Install one screw	81
Figure 1-113	Engage the left-side retainer arm	82
Figure 1-114	Install the door	82

Figure 1-115	Install the pressure-release link	83
Figure 1-116	Install the guide	83
Figure 1-117	Align the hinge	84
Figure 1-118	Install the support shaft	84
Figure 1-119	Install the tray	85
Figure 1-120	Install the cover	85
Figure 1-121	Align the tabs on the cover	86
Figure 1-122	Install the cover	86
Figure 1-123	Remove the tray	88
Figure 1-124	Release the support shaft	88
Figure 1-125	Remove the guide	89
Figure 1-126	Remove the link arm	89
Figure 1-127	Remove the door	90
Figure 1-128	Release the left-side retainer arm	90
Figure 1-129	Remove one screw	91
Figure 1-130	Release two bosses and three tabs	91
Figure 1-131	Remove the cover	91
Figure 1-132	Recycle and unpack	92
Figure 1-133	Install the cover	92
Figure 1-134	Engage two bosses and one tab	93
Figure 1-135	Check the power switch and cartridge door assembly button	93
Figure 1-136	Install one screw	93
Figure 1-137	Engage the left-side retainer arm	94
Figure 1-138	Install the door	94
Figure 1-139	Install the pressure-release link	95
Figure 1-140	Install the guide	95
Figure 1-141	Align the hinge	96
Figure 1-142	Install the support shaft	96
Figure 1-143	Install the tray	97
Figure 1-144	Remove the tray	99
Figure 1-145	Release the support shaft	100
Figure 1-146	Remove the guide	100
Figure 1-147	Remove the link arm	101
Figure 1-148	Remove the door	101
Figure 1-149	Release the left-side retainer arm	102
Figure 1-150	Remove one screw	102
Figure 1-151	Release two bosses and three tabs	103
Figure 1-152	Remove the cover	103
Figure 1-153	Remove one screw	104
Figure 1-154	Release two bosses and three tabs	104
Figure 1-155	Remove the cover	104

Figure 1-156	Duplex models, lower the duplex feed assembly	105
Figure 1-157	Remove two screws	105
Figure 1-158	Recycle and unpack	106
Figure 1-159	Install the rear cover	106
Figure 1-160	Install two screws	107
Figure 1-161	Install the cover	107
Figure 1-162	Engage two bosses and one tab	108
Figure 1-163	Check the power switch and cartridge door assembly button	108
Figure 1-164	Install one screw	108
Figure 1-165	Install the cover	109
Figure 1-166	Engage three tabs and two bosses	109
Figure 1-167	Install one screw	110
Figure 1-168	Engage the left-side retainer arm	110
Figure 1-169	Install the door	111
Figure 1-170	Install the pressure-release link	111
Figure 1-171	Install the guide	112
Figure 1-172	Align the hinge	112
Figure 1-173	Install the support shaft	113
Figure 1-174	Install the tray	113
Figure 1-175	Remove the tray	115
Figure 1-176	Release the support shaft	116
Figure 1-177	Remove the guide	116
Figure 1-178	Remove the link arm	117
Figure 1-179	Remove the door	117
Figure 1-180	Release the left-side retainer arm	118
Figure 1-181	Remove one screw	118
Figure 1-182	Release two bosses and three tabs	119
Figure 1-183	Remove the cover	119
Figure 1-184	Remove one screw	120
Figure 1-185	Release two bosses and three tabs	120
Figure 1-186	Remove the cover	120
Figure 1-187	Duplex models, lower the duplex feed assembly	121
Figure 1-188	Remove two screws	121
Figure 1-189	Locate the hinge retainer	122
Figure 1-190	Release the retainer and the hinge pin	122
Figure 1-191	Remove the cover	123
Figure 1-192	Recycle and unpack	123
Figure 1-193	Engage the right-side hinge and pin	124
Figure 1-194	Engage the left-side hinge and retainer	124
Figure 1-195	Install the rear cover	125
Figure 1-196	Install two screws	125

Figure 1-197	Install the cover	126
Figure 1-198	Engage two bosses and one tab	126
Figure 1-199	Check the power switch and cartridge door assembly button	126
Figure 1-200	Install one screw	127
Figure 1-201	Install the cover	127
Figure 1-202	Engage three tabs and two bosses	128
Figure 1-203	Install one screw	128
Figure 1-204	Engage the left-side retainer arm	129
Figure 1-205	Install the door	129
Figure 1-206	Install the pressure-release link	130
Figure 1-207	Install the guide	130
Figure 1-208	Align the hinge	131
Figure 1-209	Install the support shaft	131
Figure 1-210	Install the tray	132
Figure 1-211	Remove the tray	134
Figure 1-212	Release the support shaft	135
Figure 1-213	Remove the guide	135
Figure 1-214	Remove the link arm	136
Figure 1-215	Remove the door	136
Figure 1-216	Release the left-side retainer arm	137
Figure 1-217	Remove one screw	137
Figure 1-218	Release two bosses and three tabs	138
Figure 1-219	Remove the cover	138
Figure 1-220	Remove one screw	139
Figure 1-221	Release two bosses and three tabs	139
Figure 1-222	Remove the cover	139
Figure 1-223	Raise the ISA	140
Figure 1-224	Remove the ISA FFC cover	140
Figure 1-225	Disconnect three FFCs	141
Figure 1-226	Remove one screw	141
Figure 1-227	Pass the wire through the opening	142
Figure 1-228	Release one tab and rotate the slider pin	142
Figure 1-229	Remove the slider pin	143
Figure 1-230	Rotate the ISA towards the rear of the printer	143
Figure 1-231	Release the ISA	144
Figure 1-232	Remove the ISA	144
Figure 1-233	Disconnect one connector	145
Figure 1-234	Remove one screw	145
Figure 1-235	Release two tabs	146
Figure 1-236	Remove the cover	146
Figure 1-237	Remove one screw	147

Figure 1-238	Remove two screws	147
Figure 1-239	Lift up the control-panel assembly	148
Figure 1-240	Remove the control-panel assembly	148
Figure 1-241	Remove the USB cable	149
Figure 1-242	Remove the cover	149
Figure 1-243	Recycle and unpack	150
Figure 1-244	Release one tab	150
Figure 1-245	Release the guide	151
Figure 1-246	Remove the guide	151
Figure 1-247	Position the guide on the printer	152
Figure 1-248	Install the guide	152
Figure 1-249	Check the guide	153
Figure 1-250	Install the cover	153
Figure 1-251	Engage four bosses	154
Figure 1-252	Rotate the front edge of the cover down	154
Figure 1-253	Install the USB PCA	155
Figure 1-254	Install five screws	155
Figure 1-255	Install the control-panel FFC cover	156
Figure 1-256	Install the control-panel assembly	156
Figure 1-257	Install two screws	157
Figure 1-258	Remove one screw	157
Figure 1-259	Install the cover	158
Figure 1-260	Engage two tabs	158
Figure 1-261	Install one screw	159
Figure 1-262	Connect one connector	159
Figure 1-263	Position the ISA on the printer	160
Figure 1-264	Engage the hinge pins with the holders	160
Figure 1-265	Rotate the ISA towards the front of the printer	161
Figure 1-266	Pass the wire through the opening	161
Figure 1-267	Install one screw	162
Figure 1-268	Install the slider pin	162
Figure 1-269	Secure the slider pin	163
Figure 1-270	Connect three FFCs	163
Figure 1-271	Install the ISA FFC cover	164
Figure 1-272	Lower the ISA	164
Figure 1-273	Install the cover	165
Figure 1-274	Engage two bosses and one tab	165
Figure 1-275	Check the power switch and cartridge door assembly button	165
Figure 1-276	Install one screw	166
Figure 1-277	Install the cover	166
Figure 1-278	Engage three tabs and two bosses	167

Figure 1-279	Install one screw	167
Figure 1-280	Engage the left-side retainer arm	168
Figure 1-281	Install the door	168
Figure 1-282	Install the pressure-release link	169
Figure 1-283	Install the guide	169
Figure 1-284	Align the hinge	170
Figure 1-285	Install the support shaft	170
Figure 1-286	Install the tray	171
Figure 1-287	Remove the tray	173
Figure 1-288	Release the support shaft	174
Figure 1-289	Remove the guide	174
Figure 1-290	Remove the link arm	175
Figure 1-291	Remove the door	175
Figure 1-292	Release the left-side retainer arm	176
Figure 1-293	Remove one screw	176
Figure 1-294	Release two bosses and three tabs	177
Figure 1-295	Remove the cover	177
Figure 1-296	Remove one screw	178
Figure 1-297	Release two bosses and three tabs	178
Figure 1-298	Remove the cover	178
Figure 1-299	Disconnect one connector	179
Figure 1-300	Remove one screw	179
Figure 1-301	Release two tabs	180
Figure 1-302	Remove the cover	180
Figure 1-303	Remove one screw	181
Figure 1-304	Remove two screws	181
Figure 1-305	Lift up the control-panel assembly	182
Figure 1-306	Remove the control-panel assembly	182
Figure 1-307	Raise the ISA	183
Figure 1-308	Remove the ISA FFC cover	183
Figure 1-309	Disconnect three FFCs	184
Figure 1-310	Remove one screw	184
Figure 1-311	Pass the wire through the opening	185
Figure 1-312	Release one tab and rotate the slider pin	185
Figure 1-313	Remove the slider pin	186
Figure 1-314	Rotate the ISA towards the rear of the printer	186
Figure 1-315	Release the ISA	187
Figure 1-316	Remove the ISA	187
Figure 1-317	Remove the USB cable	188
Figure 1-318	Remove the cover	188
Figure 1-319	Release one tab	189

Figure 1-320	Release the guide	189
Figure 1-321	Remove the guide	190
Figure 1-322	Recycle and unpack	190
Figure 1-323	Position the guide on the printer	191
Figure 1-324	Install the guide	191
Figure 1-325	Check the guide	192
Figure 1-326	Install the cover	192
Figure 1-327	Engage four bosses	193
Figure 1-328	Rotate the front edge of the cover down	193
Figure 1-329	Install the USB PCA	194
Figure 1-330	Install five screws	194
Figure 1-331	Position the ISA on the printer	195
Figure 1-332	Engage the hinge pins with the holders	195
Figure 1-333	Rotate the ISA towards the front of the printer	196
Figure 1-334	Pass the wire through the opening	196
Figure 1-335	Install one screw	197
Figure 1-336	Install the slider pin	197
Figure 1-337	Secure the slider pin	198
Figure 1-338	Connect three FFCs	198
Figure 1-339	Install the ISA FFC cover	199
Figure 1-340	Lower the ISA	199
Figure 1-341	Install the control-panel FFC cover	200
Figure 1-342	Install the control-panel assembly	200
Figure 1-343	Install two screws	201
Figure 1-344	Remove one screw	201
Figure 1-345	Install the cover	202
Figure 1-346	Engage two tabs	202
Figure 1-347	Install one screw	203
Figure 1-348	Connect one connector	203
Figure 1-349	Install the cover	204
Figure 1-350	Engage two bosses and one tab	204
Figure 1-351	Check the power switch and cartridge door assembly button	204
Figure 1-352	Install one screw	205
Figure 1-353	Install the cover	205
Figure 1-354	Engage three tabs and two bosses	206
Figure 1-355	Install one screw	206
Figure 1-356	Engage the left-side retainer arm	207
Figure 1-357	Install the door	207
Figure 1-358	Install the pressure-release link	208
Figure 1-359	Install the guide	208
Figure 1-360	Align the hinge	209

Figure 1-361	Install the support shaft	209
Figure 1-362	Install the tray	210
Figure 1-363	Remove the tray	212
Figure 1-364	Release the support shaft	213
Figure 1-365	Remove the guide	213
Figure 1-366	Remove the link arm	214
Figure 1-367	Remove the door	214
Figure 1-368	Release the left-side retainer arm	215
Figure 1-369	Remove one screw	215
Figure 1-370	Release two bosses and three tabs	216
Figure 1-371	Remove the cover	216
Figure 1-372	Remove one screw	217
Figure 1-373	Release two bosses and three tabs	217
Figure 1-374	Remove the cover	217
Figure 1-375	Remove one screw	218
Figure 1-376	Release one boss and one tab	218
Figure 1-377	Remove the cover	219
Figure 1-378	Rotate the top edge of the operator cover	219
Figure 1-379	Remove the cover	220
Figure 1-380	Remove the cover	220
Figure 1-381	Recycle and unpack	221
Figure 1-382	Install the cover	221
Figure 1-383	Position the operator cover on the printer	222
Figure 1-384	Install the cover	222
Figure 1-385	Install the cover	223
Figure 1-386	Engage four bosses and tabs	223
Figure 1-387	Engage one boss and one tab	224
Figure 1-388	Install one screw	224
Figure 1-389	Install the cover	225
Figure 1-390	Engage two bosses and one tab	225
Figure 1-391	Check the power switch and cartridge door assembly button	225
Figure 1-392	Install one screw	226
Figure 1-393	Install the cover	226
Figure 1-394	Engage three tabs and two bosses	227
Figure 1-395	Install one screw	227
Figure 1-396	Engage the left-side retainer arm	228
Figure 1-397	Install the door	228
Figure 1-398	Install the pressure-release link	229
Figure 1-399	Install the guide	229
Figure 1-400	Align the hinge	230
Figure 1-401	Install the support shaft	230

Figure 1-402	Install the tray	231
Figure 1-403	Remove the tray	233
Figure 1-404	Release the support shaft	234
Figure 1-405	Remove the guide	234
Figure 1-406	Remove the link arm	235
Figure 1-407	Remove the door	235
Figure 1-408	Release the left-side retainer arm	236
Figure 1-409	Remove one screw	236
Figure 1-410	Release two bosses and three tabs	237
Figure 1-411	Remove the cover	237
Figure 1-412	Remove one screw	238
Figure 1-413	Release two bosses and three tabs	238
Figure 1-414	Remove the cover	238
Figure 1-415	Remove one screw	239
Figure 1-416	Release one boss and one tab	239
Figure 1-417	Remove the cover	240
Figure 1-418	Rotate the top edge of the operator cover	240
Figure 1-419	Remove the cover	241
Figure 1-420	Remove the cover	241
Figure 1-421	Recycle and unpack	242
Figure 1-422	Install the cover	242
Figure 1-423	Position the operator cover on the printer	243
Figure 1-424	Install the cover	243
Figure 1-425	Install the cover	244
Figure 1-426	Engage four bosses and tabs	244
Figure 1-427	Engage one boss and one tab	245
Figure 1-428	Install one screw	245
Figure 1-429	Install the cover	246
Figure 1-430	Engage two bosses and one tab	246
Figure 1-431	Check the power switch and cartridge door assembly button	246
Figure 1-432	Install one screw	247
Figure 1-433	Install the cover	247
Figure 1-434	Engage three tabs and two bosses	248
Figure 1-435	Install one screw	248
Figure 1-436	Engage the left-side retainer arm	249
Figure 1-437	Install the door	249
Figure 1-438	Install the pressure-release link	250
Figure 1-439	Install the guide	250
Figure 1-440	Align the hinge	251
Figure 1-441	Install the support shaft	251
Figure 1-442	Install the tray	252

Figure 1-443	Remove the tray	254
Figure 1-444	Release the support shaft	255
Figure 1-445	Remove the guide	255
Figure 1-446	Remove the link arm	256
Figure 1-447	Remove the door	256
Figure 1-448	Release the left-side retainer arm	257
Figure 1-449	Remove one screw	257
Figure 1-450	Release two bosses and three tabs	258
Figure 1-451	Remove the cover	258
Figure 1-452	Remove one screw	259
Figure 1-453	Release two bosses and three tabs	259
Figure 1-454	Remove the cover	259
Figure 1-455	Raise the ISA	260
Figure 1-456	Remove the ISA FFC cover	260
Figure 1-457	Disconnect three FFCs	261
Figure 1-458	Remove one screw	261
Figure 1-459	Pass the wire through the opening	262
Figure 1-460	Release one tab and rotate the slider pin	262
Figure 1-461	Remove the slider pin	263
Figure 1-462	Rotate the ISA towards the rear of the printer	263
Figure 1-463	Release the ISA	264
Figure 1-464	Remove the ISA	264
Figure 1-465	Disconnect one connector	265
Figure 1-466	Remove one screw	265
Figure 1-467	Release two tabs	266
Figure 1-468	Remove the cover	266
Figure 1-469	Remove one screw	267
Figure 1-470	Remove two screws	267
Figure 1-471	Lift up the control-panel assembly	268
Figure 1-472	Remove the control-panel assembly	268
Figure 1-473	Remove the USB cable	269
Figure 1-474	Remove the cover	269
Figure 1-475	Remove one screw	270
Figure 1-476	Release one boss and one tab	270
Figure 1-477	Remove the cover	271
Figure 1-478	Release two tabs	271
Figure 1-479	Recycle and unpack	272
Figure 1-480	Engage two tabs	273
Figure 1-481	Install the cover	273
Figure 1-482	Engage four bosses and tabs	274
Figure 1-483	Engage one boss and one tab	274

Figure 1-484	Install one screw	275
Figure 1-485	Install the cover	275
Figure 1-486	Engage four bosses	276
Figure 1-487	Rotate the front edge of the cover down	276
Figure 1-488	Install the USB PCA	277
Figure 1-489	Install five screws	277
Figure 1-490	Install the control-panel FFC cover	278
Figure 1-491	Install the control-panel assembly	278
Figure 1-492	Install two screws	279
Figure 1-493	Remove one screw	279
Figure 1-494	Install the cover	280
Figure 1-495	Engage two tabs	280
Figure 1-496	Install one screw	281
Figure 1-497	Connect one connector	281
Figure 1-498	Position the ISA on the printer	282
Figure 1-499	Engage the hinge pins with the holders	282
Figure 1-500	Rotate the ISA towards the front of the printer	283
Figure 1-501	Pass the wire through the opening	283
Figure 1-502	Install one screw	284
Figure 1-503	Install the slider pin	284
Figure 1-504	Secure the slider pin	285
Figure 1-505	Connect three FFCs	285
Figure 1-506	Install the ISA FFC cover	286
Figure 1-507	Lower the ISA	286
Figure 1-508	Install the cover	287
Figure 1-509	Engage two bosses and one tab	287
Figure 1-510	Check the power switch and cartridge door assembly button	287
Figure 1-511	Install one screw	288
Figure 1-512	Install the cover	288
Figure 1-513	Engage three tabs and two bosses	289
Figure 1-514	Install one screw	289
Figure 1-515	Engage the left-side retainer arm	290
Figure 1-516	Install the door	290
Figure 1-517	Install the pressure-release link	291
Figure 1-518	Install the guide	291
Figure 1-519	Align the hinge	292
Figure 1-520	Install the support shaft	292
Figure 1-521	Install the tray	293
Figure 1-522	Remove the tray	295
Figure 1-523	Release the support shaft	296
Figure 1-524	Remove the guide	296

Figure 1-525	Remove the link arm	297
Figure 1-526	Remove the door	297
Figure 1-527	Release the left-side retainer arm	298
Figure 1-528	Remove one screw	298
Figure 1-529	Release two bosses and three tabs	299
Figure 1-530	Remove the cover	299
Figure 1-531	Raise the ISA	300
Figure 1-532	Remove the ISA FFC cover	300
Figure 1-533	Disconnect three FFCs	301
Figure 1-534	Remove one screw	301
Figure 1-535	Pass the wire through the opening	302
Figure 1-536	Release one tab and rotate the slider pin	302
Figure 1-537	Remove the slider pin	303
Figure 1-538	Rotate the ISA towards the rear of the printer	303
Figure 1-539	Release the ISA	304
Figure 1-540	Remove the ISA	304
Figure 1-541	Recycle and unpack	305
Figure 1-542	Position the ISA on the printer	305
Figure 1-543	Engage the hinge pins with the holders	306
Figure 1-544	Rotate the ISA towards the front of the printer	306
Figure 1-545	Pass the wire through the opening	307
Figure 1-546	Install one screw	307
Figure 1-547	Install the slider pin	308
Figure 1-548	Secure the slider pin	308
Figure 1-549	Connect three FFCs	309
Figure 1-550	Install the ISA FFC cover	309
Figure 1-551	Lower the ISA	310
Figure 1-552	Install the cover	310
Figure 1-553	Engage three tabs and two bosses	311
Figure 1-554	Install one screw	311
Figure 1-555	Engage the left-side retainer arm	312
Figure 1-556	Install the door	312
Figure 1-557	Install the pressure-release link	313
Figure 1-558	Install the guide	313
Figure 1-559	Align the hinge	314
Figure 1-560	Install the support shaft	314
Figure 1-561	Install the tray	315
Figure 1-562	Release one tab and rotate the slider pin	317
Figure 1-563	Remove the slider pin	317
Figure 1-564	Lower the support arm	318
Figure 1-565	Before proceeding take note	318

Figure 1-566	Remove one screw	319
Figure 1-567	Remove the support arm	319
Figure 1-568	Recycle and unpack	320
Figure 1-569	Install the lift assembly	320
Figure 1-570	Lower the lift assembly	321
Figure 1-571	Before proceeding take note	321
Figure 1-572	Install one screw	322
Figure 1-573	Install the slider pin	322
Figure 1-574	Secure the slider pin	323
Figure 1-575	Remove the tray	326
Figure 1-576	Release the support shaft	327
Figure 1-577	Remove the guide	327
Figure 1-578	Remove the link arm	328
Figure 1-579	Remove the door	328
Figure 1-580	Release the left-side retainer arm	329
Figure 1-581	Remove one screw	329
Figure 1-582	Release two bosses and three tabs	330
Figure 1-583	Remove the cover	330
Figure 1-584	Remove one screw	331
Figure 1-585	Release two bosses and three tabs	331
Figure 1-586	Remove the cover	331
Figure 1-587	Duplex models, lower the duplex feed assembly	332
Figure 1-588	Remove two screws	332
Figure 1-589	Disconnect one connector	333
Figure 1-590	Remove the cover	333
Figure 1-591	Disconnect two connectors	334
Figure 1-592	Remove four screws	334
Figure 1-593	Release the pressure-release arm	335
Figure 1-594	Remove the fuser	335
Figure 1-595	Recycle and unpack	336
Figure 1-596	Install the fuser	336
Figure 1-597	Connect the pressure-release arm	337
Figure 1-598	Install four screws	337
Figure 1-599	Connect two connectors	338
Figure 1-600	Install the cover	338
Figure 1-601	Connect one connector	339
Figure 1-602	Install the rear cover	339
Figure 1-603	Install two screws	340
Figure 1-604	Install the cover	340
Figure 1-605	Engage two bosses and one tab	341
Figure 1-606	Check the power switch and cartridge door assembly button	341

Figure 1-607	Install one screw	341
Figure 1-608	Install the cover	342
Figure 1-609	Engage three tabs and two bosses	342
Figure 1-610	Install one screw	343
Figure 1-611	Engage the left-side retainer arm	343
Figure 1-612	Install the door	344
Figure 1-613	Install the pressure-release link	344
Figure 1-614	Install the guide	345
Figure 1-615	Align the hinge	345
Figure 1-616	Install the support shaft	346
Figure 1-617	Install the tray	346
Figure 1-618	Remove the tray	349
Figure 1-619	Release the support shaft	349
Figure 1-620	Remove the guide	350
Figure 1-621	Remove the link arm	350
Figure 1-622	Remove the door	351
Figure 1-623	Release the left-side retainer arm	351
Figure 1-624	Remove one screw	352
Figure 1-625	Release two bosses and three tabs	352
Figure 1-626	Remove the cover	353
Figure 1-627	Remove one screw	353
Figure 1-628	Release two bosses and three tabs	353
Figure 1-629	Remove the cover	354
Figure 1-630	Duplex models, lower the duplex feed assembly	354
Figure 1-631	Remove two screws	355
Figure 1-632	Raise the ISA	355
Figure 1-633	Remove the ISA FFC cover	356
Figure 1-634	Disconnect three FFCs	356
Figure 1-635	Remove one screw	357
Figure 1-636	Pass the wire through the opening	357
Figure 1-637	Release one tab and rotate the slider pin	358
Figure 1-638	Remove the slider pin	358
Figure 1-639	Rotate the ISA towards the rear of the printer	359
Figure 1-640	Release the ISA	359
Figure 1-641	Remove the ISA	360
Figure 1-642	Disconnect one connector	360
Figure 1-643	Remove one screw	361
Figure 1-644	Release two tabs	361
Figure 1-645	Remove the cover	362
Figure 1-646	Remove one screw	362
Figure 1-647	Remove two screws	363

Figure 1-648	Lift up the control-panel assembly	363
Figure 1-649	Remove the control-panel assembly	364
Figure 1-650	Remove the USB cable	364
Figure 1-651	Remove the cover	365
Figure 1-652	Remove one screw	365
Figure 1-653	Release one boss and one tab	366
Figure 1-654	Remove the cover	366
Figure 1-655	Release two tabs	367
Figure 1-656	Disconnect one connector	367
Figure 1-657	Remove the cover	368
Figure 1-658	Disconnect two connectors	368
Figure 1-659	Remove four screws	369
Figure 1-660	Release the pressure-release arm	369
Figure 1-661	Remove the fuser	370
Figure 1-662	Place the printer bottom-side face forward	370
Figure 1-663	Remove one screw and the guide	371
Figure 1-664	Move the link arm out of the way	371
Figure 1-665	Remove two screws	372
Figure 1-666	Move the pressure-release arm out of the way	372
Figure 1-667	Release the assembly	373
Figure 1-668	Remove the assembly	373
Figure 1-669	Recycle and unpack	374
Figure 1-670	Install the assembly	374
Figure 1-671	Install the pressure-release arm	375
Figure 1-672	Install two screws	375
Figure 1-673	Place the printer bottom-side face forward	376
Figure 1-674	Install the guide	376
Figure 1-675	Install the fuser	377
Figure 1-676	Connect the pressure-release arm	377
Figure 1-677	Install four screws	378
Figure 1-678	Connect two connectors	378
Figure 1-679	Install the cover	379
Figure 1-680	Connect one connector	379
Figure 1-681	Engage two tabs	380
Figure 1-682	Install the cover	380
Figure 1-683	Engage four bosses and tabs	381
Figure 1-684	Engage one boss and one tab	381
Figure 1-685	Install one screw	382
Figure 1-686	Install the cover	382
Figure 1-687	Engage four bosses	383
Figure 1-688	Rotate the front edge of the cover down	383

Figure 1-689	Install the USB PCA	384
Figure 1-690	Install five screws	384
Figure 1-691	Install the control-panel FFC cover	385
Figure 1-692	Install the control-panel assembly	385
Figure 1-693	Install two screws	386
Figure 1-694	Remove one screw	386
Figure 1-695	Install the cover	387
Figure 1-696	Engage two tabs	387
Figure 1-697	Install one screw	388
Figure 1-698	Connect one connector	388
Figure 1-699	Position the ISA on the printer	389
Figure 1-700	Engage the hinge pins with the holders	389
Figure 1-701	Rotate the ISA towards the front of the printer	390
Figure 1-702	Pass the wire through the opening	390
Figure 1-703	Install one screw	391
Figure 1-704	Install the slider pin	391
Figure 1-705	Secure the slider pin	392
Figure 1-706	Connect three FFCs	392
Figure 1-707	Install the ISA FFC cover	393
Figure 1-708	Lower the ISA	393
Figure 1-709	Install the rear cover	394
Figure 1-710	Install two screws	394
Figure 1-711	Install the cover	395
Figure 1-712	Engage two bosses and one tab	395
Figure 1-713	Check the power switch and cartridge door assembly button	395
Figure 1-714	Install one screw	396
Figure 1-715	Install the cover	396
Figure 1-716	Engage three tabs and two bosses	397
Figure 1-717	Install one screw	397
Figure 1-718	Engage the left-side retainer arm	398
Figure 1-719	Install the door	398
Figure 1-720	Install the pressure-release link	399
Figure 1-721	Install the guide	399
Figure 1-722	Align the hinge	400
Figure 1-723	Install the support shaft	400
Figure 1-724	Install the tray	401
Figure 1-725	Remove the tray	403
Figure 1-726	Release the support shaft	403
Figure 1-727	Remove the guide	404
Figure 1-728	Remove the link arm	404
Figure 1-729	Remove the door	405

Figure 1-730	Release the left-side retainer arm	405
Figure 1-731	Remove one screw	406
Figure 1-732	Release two bosses and three tabs	406
Figure 1-733	Remove the cover	406
Figure 1-734	Remove the motor	407
Figure 1-735	Recycle and unpack	407
Figure 1-736	Install the motor	408
Figure 1-737	Install the cover	408
Figure 1-738	Engage two bosses and one tab	409
Figure 1-739	Check the power switch and cartridge door assembly button	409
Figure 1-740	Install one screw	409
Figure 1-741	Engage the left-side retainer arm	410
Figure 1-742	Install the door	410
Figure 1-743	Install the pressure-release link	411
Figure 1-744	Install the guide	411
Figure 1-745	Align the hinge	412
Figure 1-746	Install the support shaft	412
Figure 1-747	Install the tray	413
Figure 1-748	Remove the tray	415
Figure 1-749	Release the support shaft	416
Figure 1-750	Remove the guide	416
Figure 1-751	Remove the link arm	417
Figure 1-752	Remove the door	417
Figure 1-753	Release the left-side retainer arm	418
Figure 1-754	Remove one screw	418
Figure 1-755	Release two bosses and three tabs	419
Figure 1-756	Remove the cover	419
Figure 1-757	Release one tab	420
Figure 1-758	Remove the switch lever	420
Figure 1-759	Disconnect one connector	421
Figure 1-760	Release one tab and remove the PCA	421
Figure 1-761	Recycle and unpack	422
Figure 1-762	Install the PCA	422
Figure 1-763	Connect one connector and install the wire harness in the guide	423
Figure 1-764	Install the switch lever	423
Figure 1-765	Install the cover	424
Figure 1-766	Engage two bosses and one tab	424
Figure 1-767	Check the power switch and cartridge door assembly button	424
Figure 1-768	Install one screw	425
Figure 1-769	Engage the left-side retainer arm	425
Figure 1-770	Install the door	426

Figure 1-771	Install the pressure-release link	426
Figure 1-772	Install the guide	427
Figure 1-773	Align the hinge	427
Figure 1-774	Install the support shaft	428
Figure 1-775	Install the tray	428
Figure 1-776	Remove the tray	430
Figure 1-777	Release the support shaft	431
Figure 1-778	Remove the guide	431
Figure 1-779	Remove the link arm	432
Figure 1-780	Remove the door	432
Figure 1-781	Release the left-side retainer arm	433
Figure 1-782	Remove one screw	433
Figure 1-783	Release two bosses and three tabs	434
Figure 1-784	Remove the cover	434
Figure 1-785	Remove four screws	435
Figure 1-786	Disconnect one connector and remove the PCA	435
Figure 1-787	Recycle and unpack	436
Figure 1-788	Connect one connector and install the PCA	436
Figure 1-789	Install four screws	437
Figure 1-790	Install the cover	437
Figure 1-791	Engage three tabs and two bosses	438
Figure 1-792	Install one screw	438
Figure 1-793	Engage the left-side retainer arm	439
Figure 1-794	Install the door	439
Figure 1-795	Install the pressure-release link	440
Figure 1-796	Install the guide	440
Figure 1-797	Align the hinge	441
Figure 1-798	Install the support shaft	441
Figure 1-799	Install the tray	442
Figure 1-800	Remove the tray	444
Figure 1-801	Release the support shaft	445
Figure 1-802	Remove the guide	445
Figure 1-803	Remove the link arm	446
Figure 1-804	Remove the door	446
Figure 1-805	Release the left-side retainer arm	447
Figure 1-806	Remove one screw	447
Figure 1-807	Release two bosses and three tabs	448
Figure 1-808	Remove the cover	448
Figure 1-809	Remove four screws	449
Figure 1-810	Disconnect one connector and remove the PCA	449
Figure 1-811	Disconnect one connector	450

Figure 1-812	Remove two screws	450
Figure 1-813	Remove the walkup USB PCA	451
Figure 1-814	Recycle and unpack	451
Figure 1-815	Install the walkup USB PCA	452
Figure 1-816	Install two screws	452
Figure 1-817	Connect one connector	453
Figure 1-818	Connect one connector and install the PCA	453
Figure 1-819	Install four screws	454
Figure 1-820	Install the cover	454
Figure 1-821	Engage three tabs and two bosses	455
Figure 1-822	Install one screw	455
Figure 1-823	Engage the left-side retainer arm	456
Figure 1-824	Install the door	456
Figure 1-825	Install the pressure-release link	457
Figure 1-826	Install the guide	457
Figure 1-827	Align the hinge	458
Figure 1-828	Install the support shaft	458
Figure 1-829	Install the tray	459
Figure 1-830	Remove the tray	461
Figure 1-831	Release the support shaft	462
Figure 1-832	Remove the guide	462
Figure 1-833	Remove the link arm	463
Figure 1-834	Remove the door	463
Figure 1-835	Release the left-side retainer arm	464
Figure 1-836	Remove one screw	464
Figure 1-837	Release two bosses and three tabs	465
Figure 1-838	Remove the cover	465
Figure 1-839	Remove one screw	466
Figure 1-840	Remove the wireless PCA	466
Figure 1-841	Recycle and unpack	467
Figure 1-842	Install the PCA	467
Figure 1-843	Install one screw	468
Figure 1-844	Install the cover	468
Figure 1-845	Engage three tabs and two bosses	469
Figure 1-846	Install one screw	469
Figure 1-847	Engage the left-side retainer arm	470
Figure 1-848	Install the door	470
Figure 1-849	Install the pressure-release link	471
Figure 1-850	Install the guide	471
Figure 1-851	Align the hinge	472
Figure 1-852	Install the support shaft	472

Figure 1-853	Install the tray	473
Figure 1-854	Remove the tray	475
Figure 1-855	Release the support shaft	476
Figure 1-856	Remove the guide	476
Figure 1-857	Remove the link arm	477
Figure 1-858	Remove the door	477
Figure 1-859	Release the left-side retainer arm	478
Figure 1-860	Remove one screw	478
Figure 1-861	Release two bosses and three tabs	479
Figure 1-862	Remove the cover	479
Figure 1-863	Remove four screws	480
Figure 1-864	Disconnect one connector and remove the PCA	480
Figure 1-865	Remove one screw	481
Figure 1-866	Remove the wireless PCA	481
Figure 1-867	Disconnect all of the connectors and FFCs	482
Figure 1-868	Remove the fax PCA support bracket	482
Figure 1-869	Remove the formatter PCA	483
Figure 1-870	Recycle and unpack	483
Figure 1-871	Install the formatter PCA	484
Figure 1-872	Remove the fax PCA support bracket	484
Figure 1-873	Connect all of the connectors and FFCs	485
Figure 1-874	Install the PCA	485
Figure 1-875	Install one screw	486
Figure 1-876	Connect one connector and install the PCA	486
Figure 1-877	Install four screws	487
Figure 1-878	Install the cover	487
Figure 1-879	Engage three tabs and two bosses	488
Figure 1-880	Install one screw	488
Figure 1-881	Engage the left-side retainer arm	489
Figure 1-882	Install the door	489
Figure 1-883	Install the pressure-release link	490
Figure 1-884	Install the guide	490
Figure 1-885	Align the hinge	491
Figure 1-886	Install the support shaft	491
Figure 1-887	Install the tray	492
Figure 1-888	Remove the tray	494
Figure 1-889	Release the support shaft	494
Figure 1-890	Remove the guide	495
Figure 1-891	Remove the link arm	495
Figure 1-892	Remove the door	496
Figure 1-893	Release the left-side retainer arm	496

Figure 1-894	Remove one screw	497
Figure 1-895	Release two bosses and three tabs	497
Figure 1-896	Remove the cover	498
Figure 1-897	Disconnect one connector	498
Figure 1-898	Release two tabs	499
Figure 1-899	Remove the fan	499
Figure 1-900	Recycle and unpack	500
Figure 1-901	Install the fan	500
Figure 1-902	Connect one connector	501
Figure 1-903	Install the cover	501
Figure 1-904	Engage three tabs and two bosses	502
Figure 1-905	Install one screw	502
Figure 1-906	Engage the left-side retainer arm	503
Figure 1-907	Install the door	503
Figure 1-908	Install the pressure-release link	504
Figure 1-909	Install the guide	504
Figure 1-910	Align the hinge	505
Figure 1-911	Install the support shaft	505
Figure 1-912	Install the tray	506
Figure 1-913	Remove the tray	508
Figure 1-914	Release the support shaft	509
Figure 1-915	Remove the guide	509
Figure 1-916	Remove the link arm	510
Figure 1-917	Remove the door	510
Figure 1-918	Release the left-side retainer arm	511
Figure 1-919	Remove one screw	511
Figure 1-920	Release two bosses and three tabs	512
Figure 1-921	Remove the cover	512
Figure 1-922	Disconnect one connector	513
Figure 1-923	Release two tabs	513
Figure 1-924	Remove the fan	514
Figure 1-925	Remove one screw	514
Figure 1-926	Release one tab	515
Figure 1-927	Release one tab	515
Figure 1-928	Remove the holder	516
Figure 1-929	Recycle and unpack	516
Figure 1-930	Install the holder	517
Figure 1-931	Engage one tab	517
Figure 1-932	Engage one tab	518
Figure 1-933	Install one screw	518
Figure 1-934	Install the fan	519

Figure 1-935	Connect one connector	519
Figure 1-936	Install the cover	520
Figure 1-937	Engage three tabs and two bosses	520
Figure 1-938	Install one screw	520
Figure 1-939	Engage the left-side retainer arm	521
Figure 1-940	Install the door	521
Figure 1-941	Install the pressure-release link	522
Figure 1-942	Install the guide	522
Figure 1-943	Align the hinge	523
Figure 1-944	Install the support shaft	523
Figure 1-945	Install the tray	524
Figure 1-946	Remove the tray	526
Figure 1-947	Release the support shaft	527
Figure 1-948	Remove the guide	527
Figure 1-949	Remove the link arm	528
Figure 1-950	Remove the door	528
Figure 1-951	Release the left-side retainer arm	529
Figure 1-952	Remove one screw	529
Figure 1-953	Release two bosses and three tabs	530
Figure 1-954	Remove the cover	530
Figure 1-955	Remove one screw	531
Figure 1-956	Release two bosses and three tabs	531
Figure 1-957	Remove the cover	531
Figure 1-958	Raise the ISA	532
Figure 1-959	Remove the ISA FFC cover	532
Figure 1-960	Disconnect three FFCs	533
Figure 1-961	Remove one screw	533
Figure 1-962	Pass the wire through the opening	534
Figure 1-963	Release one tab and rotate the slider pin	534
Figure 1-964	Remove the slider pin	535
Figure 1-965	Rotate the ISA towards the rear of the printer	535
Figure 1-966	Release the ISA	536
Figure 1-967	Remove the ISA	536
Figure 1-968	Disconnect one connector	537
Figure 1-969	Remove one screw	537
Figure 1-970	Release two tabs	538
Figure 1-971	Remove the cover	538
Figure 1-972	Remove one screw	539
Figure 1-973	Remove two screws	539
Figure 1-974	Lift up the control-panel assembly	540
Figure 1-975	Remove the control-panel assembly	540

Figure 1-976	Remove the USB cable	541
Figure 1-977	Remove the cover	541
Figure 1-978	Remove one screw	542
Figure 1-979	Release one boss and one tab	542
Figure 1-980	Remove the cover	543
Figure 1-981	Release two tabs	543
Figure 1-982	Disconnect one FFC and one connector	544
Figure 1-983	Remove the laser scanner	544
Figure 1-984	Recycle and unpack	545
Figure 1-985	Connect one FFC and one connector	545
Figure 1-986	Install the laser scanner	546
Figure 1-987	Engage two tabs	546
Figure 1-988	Install the cover	547
Figure 1-989	Engage four bosses and tabs	547
Figure 1-990	Engage one boss and one tab	548
Figure 1-991	Install one screw	548
Figure 1-992	Install the cover	549
Figure 1-993	Engage four bosses	549
Figure 1-994	Rotate the front edge of the cover down	550
Figure 1-995	Install the USB PCA	550
Figure 1-996	Install five screws	551
Figure 1-997	Install the control-panel FFC cover	551
Figure 1-998	Install the control-panel assembly	552
Figure 1-999	Install two screws	552
Figure 1-1000	Remove one screw	553
Figure 1-1001	Install the cover	553
Figure 1-1002	Engage two tabs	554
Figure 1-1003	Install one screw	554
Figure 1-1004	Connect one connector	555
Figure 1-1005	Position the ISA on the printer	555
Figure 1-1006	Engage the hinge pins with the holders	556
Figure 1-1007	Rotate the ISA towards the front of the printer	556
Figure 1-1008	Pass the wire through the opening	557
Figure 1-1009	Install one screw	557
Figure 1-1010	Install the slider pin	558
Figure 1-1011	Secure the slider pin	558
Figure 1-1012	Connect three FFCs	559
Figure 1-1013	Install the ISA FFC cover	559
Figure 1-1014	Lower the ISA	560
Figure 1-1015	Install the cover	560
Figure 1-1016	Engage two bosses and one tab	561

Figure 1-1017	Check the power switch and cartridge door assembly button	561
Figure 1-1018	Install one screw	561
Figure 1-1019	Install the cover	562
Figure 1-1020	Engage three tabs and two bosses	562
Figure 1-1021	Install one screw	563
Figure 1-1022	Engage the left-side retainer arm	563
Figure 1-1023	Install the door	564
Figure 1-1024	Install the pressure-release link	564
Figure 1-1025	Install the guide	565
Figure 1-1026	Align the hinge	565
Figure 1-1027	Install the support shaft	566
Figure 1-1028	Install the tray	566
Figure 1-1029	Remove the tray	568
Figure 1-1030	Release the support shaft	568
Figure 1-1031	Remove the guide	569
Figure 1-1032	Remove the link arm	569
Figure 1-1033	Remove the door	570
Figure 1-1034	Release the left-side retainer arm	570
Figure 1-1035	Remove one screw	571
Figure 1-1036	Release two bosses and three tabs	571
Figure 1-1037	Remove the cover	572
Figure 1-1038	Remove one screw	572
Figure 1-1039	Release two bosses and three tabs	572
Figure 1-1040	Remove the cover	573
Figure 1-1041	Raise the ISA	573
Figure 1-1042	Remove the ISA FFC cover	574
Figure 1-1043	Disconnect three FFCs	574
Figure 1-1044	Remove one screw	575
Figure 1-1045	Pass the wire through the opening	575
Figure 1-1046	Release one tab and rotate the slider pin	576
Figure 1-1047	Remove the slider pin	576
Figure 1-1048	Rotate the ISA towards the rear of the printer	577
Figure 1-1049	Release the ISA	577
Figure 1-1050	Remove the ISA	578
Figure 1-1051	Disconnect one connector	578
Figure 1-1052	Remove one screw	579
Figure 1-1053	Release two tabs	579
Figure 1-1054	Remove the cover	580
Figure 1-1055	Remove one screw	580
Figure 1-1056	Remove two screws	581
Figure 1-1057	Lift up the control-panel assembly	581

Figure 1-1058	Remove the control-panel assembly	582
Figure 1-1059	Remove the USB cable	582
Figure 1-1060	Remove the cover	583
Figure 1-1061	Remove one screw	583
Figure 1-1062	Release one boss and one tab	584
Figure 1-1063	Remove the cover	584
Figure 1-1064	Remove the guide	585
Figure 1-1065	Remove two screws	585
Figure 1-1066	Disconnect one connector	585
Figure 1-1067	Remove the guide	586
Figure 1-1068	Remove three screws	586
Figure 1-1069	Remove the bracket	586
Figure 1-1070	Install the bracket	587
Figure 1-1071	Install three screws	587
Figure 1-1072	Install the guide	587
Figure 1-1073	Connect one connector	588
Figure 1-1074	Install two screws	588
Figure 1-1075	Install the guide	588
Figure 1-1076	Install the cover	589
Figure 1-1077	Engage four bosses and tabs	589
Figure 1-1078	Engage one boss and one tab	590
Figure 1-1079	Install one screw	590
Figure 1-1080	Install the cover	591
Figure 1-1081	Engage four bosses	591
Figure 1-1082	Rotate the front edge of the cover down	592
Figure 1-1083	Install the USB PCA	592
Figure 1-1084	Install five screws	593
Figure 1-1085	Install the control-panel FFC cover	593
Figure 1-1086	Install the control-panel assembly	594
Figure 1-1087	Install two screws	594
Figure 1-1088	Remove one screw	595
Figure 1-1089	Install the cover	595
Figure 1-1090	Engage two tabs	596
Figure 1-1091	Install one screw	596
Figure 1-1092	Connect one connector	597
Figure 1-1093	Position the ISA on the printer	597
Figure 1-1094	Engage the hinge pins with the holders	598
Figure 1-1095	Rotate the ISA towards the front of the printer	598
Figure 1-1096	Pass the wire through the opening	599
Figure 1-1097	Install one screw	599
Figure 1-1098	Install the slider pin	600

Figure 1-1099	Secure the slider pin	600
Figure 1-1100	Connect three FFCs	601
Figure 1-1101	Install the ISA FFC cover	601
Figure 1-1102	Lower the ISA	602
Figure 1-1103	Install the cover	602
Figure 1-1104	Engage two bosses and one tab	603
Figure 1-1105	Check the power switch and cartridge door assembly button	603
Figure 1-1106	Install one screw	603
Figure 1-1107	Install the cover	604
Figure 1-1108	Engage three tabs and two bosses	604
Figure 1-1109	Install one screw	605
Figure 1-1110	Engage the left-side retainer arm	605
Figure 1-1111	Install the door	606
Figure 1-1112	Install the pressure-release link	606
Figure 1-1113	Install the guide	607
Figure 1-1114	Align the hinge	607
Figure 1-1115	Install the support shaft	608
Figure 1-1116	Install the tray	608
Figure 1-1117	Remove the tray	611
Figure 1-1118	Release the support shaft	611
Figure 1-1119	Remove the guide	612
Figure 1-1120	Remove the link arm	612
Figure 1-1121	Remove the door	613
Figure 1-1122	Release the left-side retainer arm	613
Figure 1-1123	Remove one screw	614
Figure 1-1124	Release two bosses and three tabs	614
Figure 1-1125	Remove the cover	615
Figure 1-1126	Remove one screw	615
Figure 1-1127	Release two bosses and three tabs	615
Figure 1-1128	Remove the cover	616
Figure 1-1129	Raise the ISA	616
Figure 1-1130	Remove the ISA FFC cover	617
Figure 1-1131	Disconnect three FFCs	617
Figure 1-1132	Remove one screw	618
Figure 1-1133	Pass the wire through the opening	618
Figure 1-1134	Release one tab and rotate the slider pin	619
Figure 1-1135	Remove the slider pin	619
Figure 1-1136	Rotate the ISA towards the rear of the printer	620
Figure 1-1137	Release the ISA	620
Figure 1-1138	Remove the ISA	621
Figure 1-1139	Disconnect one connector	621

Figure 1-1140	Remove one screw	622
Figure 1-1141	Release two tabs	622
Figure 1-1142	Remove the cover	623
Figure 1-1143	Remove one screw	623
Figure 1-1144	Remove two screws	624
Figure 1-1145	Lift up the control-panel assembly	624
Figure 1-1146	Remove the control-panel assembly	625
Figure 1-1147	Remove the USB cable	625
Figure 1-1148	Remove the cover	626
Figure 1-1149	Remove the cover	626
Figure 1-1150	Remove one screw	627
Figure 1-1151	Release one boss and one tab	627
Figure 1-1152	Remove the cover	628
Figure 1-1153	Release two tabs	628
Figure 1-1154	Remove one screw	629
Figure 1-1155	Remove the NFC PCA	629
Figure 1-1156	Release the FFC from the guide	630
Figure 1-1157	Release the FFC from the guide	630
Figure 1-1158	Disconnect and remove the FFC	631
Figure 1-1159	Recycle and unpack	631
Figure 1-1160	Connect the FFC	632
Figure 1-1161	Install the FFC in the guide	632
Figure 1-1162	Install the FFC in the guide	633
Figure 1-1163	Connect one FFC	633
Figure 1-1164	Install the NFC PCA	634
Figure 1-1165	Install one screw	634
Figure 1-1166	Engage two tabs	635
Figure 1-1167	Install the cover	635
Figure 1-1168	Engage four bosses and tabs	636
Figure 1-1169	Engage one boss and one tab	636
Figure 1-1170	Install one screw	637
Figure 1-1171	Remove the cover	637
Figure 1-1172	Install the cover	638
Figure 1-1173	Engage four bosses	638
Figure 1-1174	Rotate the front edge of the cover down	639
Figure 1-1175	Install the USB PCA	639
Figure 1-1176	Install five screws	640
Figure 1-1177	Install the control-panel FFC cover	640
Figure 1-1178	Install the control-panel assembly	641
Figure 1-1179	Install two screws	641
Figure 1-1180	Remove one screw	642

Figure 1-1181	Install the cover	642
Figure 1-1182	Engage two tabs	643
Figure 1-1183	Install one screw	643
Figure 1-1184	Connect one connector	644
Figure 1-1185	Position the ISA on the printer	644
Figure 1-1186	Engage the hinge pins with the holders	645
Figure 1-1187	Rotate the ISA towards the front of the printer	645
Figure 1-1188	Pass the wire through the opening	646
Figure 1-1189	Install one screw	646
Figure 1-1190	Install the slider pin	647
Figure 1-1191	Secure the slider pin	647
Figure 1-1192	Connect three FFCs	648
Figure 1-1193	Install the ISA FFC cover	648
Figure 1-1194	Lower the ISA	649
Figure 1-1195	Install the cover	649
Figure 1-1196	Engage two bosses and one tab	650
Figure 1-1197	Check the power switch and cartridge door assembly button	650
Figure 1-1198	Install one screw	650
Figure 1-1199	Install the cover	651
Figure 1-1200	Engage three tabs and two bosses	651
Figure 1-1201	Install one screw	652
Figure 1-1202	Engage the left-side retainer arm	652
Figure 1-1203	Install the door	653
Figure 1-1204	Install the pressure-release link	653
Figure 1-1205	Install the guide	654
Figure 1-1206	Align the hinge	654
Figure 1-1207	Install the support shaft	655
Figure 1-1208	Install the tray	655
Figure 1-1209	Remove the tray	657
Figure 1-1210	Release the support shaft	658
Figure 1-1211	Remove the guide	658
Figure 1-1212	Remove the link arm	659
Figure 1-1213	Remove the door	659
Figure 1-1214	Release the left-side retainer arm	660
Figure 1-1215	Remove one screw	660
Figure 1-1216	Release two bosses and three tabs	661
Figure 1-1217	Remove the cover	661
Figure 1-1218	Remove one screw	662
Figure 1-1219	Release two bosses and three tabs	662
Figure 1-1220	Remove the cover	662
Figure 1-1221	Remove one screw	663

Figure 1-1222	Release one boss and one tab	663
Figure 1-1223	Remove the cover	664
Figure 1-1224	Release two tabs	664
Figure 1-1225	Disconnect the FFC	665
Figure 1-1226	Release the FFC from the guide	665
Figure 1-1227	Disconnect and remove the FFC	666
Figure 1-1228	Recycle and unpack	666
Figure 1-1229	Connect the FFC	667
Figure 1-1230	Install the FFC in the guide	667
Figure 1-1231	Connect the FFC	668
Figure 1-1232	Engage two tabs	668
Figure 1-1233	Install the cover	669
Figure 1-1234	Engage four bosses and tabs	669
Figure 1-1235	Engage one boss and one tab	670
Figure 1-1236	Install one screw	670
Figure 1-1237	Install the cover	671
Figure 1-1238	Engage two bosses and one tab	671
Figure 1-1239	Check the power switch and cartridge door assembly button	671
Figure 1-1240	Install one screw	672
Figure 1-1241	Install the cover	672
Figure 1-1242	Engage three tabs and two bosses	673
Figure 1-1243	Install one screw	673
Figure 1-1244	Engage the left-side retainer arm	674
Figure 1-1245	Install the door	674
Figure 1-1246	Install the pressure-release link	675
Figure 1-1247	Install the guide	675
Figure 1-1248	Align the hinge	676
Figure 1-1249	Install the support shaft	676
Figure 1-1250	Install the tray	677
Figure 1-1251	Remove the tray	679
Figure 1-1252	Release the support shaft	680
Figure 1-1253	Remove the guide	680
Figure 1-1254	Remove the link arm	681
Figure 1-1255	Remove the door	681
Figure 1-1256	Release the left-side retainer arm	682
Figure 1-1257	Remove one screw	682
Figure 1-1258	Release two bosses and three tabs	683
Figure 1-1259	Remove the cover	683
Figure 1-1260	Remove one screw	684
Figure 1-1261	Release two bosses and three tabs	684
Figure 1-1262	Remove the cover	684

Figure 1-1263	Raise the ISA	685
Figure 1-1264	Remove the ISA FFC cover	685
Figure 1-1265	Disconnect three FFCs	686
Figure 1-1266	Remove one screw	686
Figure 1-1267	Pass the wire through the opening	687
Figure 1-1268	Release one tab and rotate the slider pin	687
Figure 1-1269	Remove the slider pin	688
Figure 1-1270	Rotate the ISA towards the rear of the printer	688
Figure 1-1271	Release the ISA	689
Figure 1-1272	Remove the ISA	689
Figure 1-1273	Disconnect one connector	690
Figure 1-1274	Remove one screw	690
Figure 1-1275	Release two tabs	691
Figure 1-1276	Remove the cover	691
Figure 1-1277	Remove one screw	692
Figure 1-1278	Remove two screws	692
Figure 1-1279	Lift up the control-panel assembly	693
Figure 1-1280	Remove the control-panel assembly	693
Figure 1-1281	Remove the USB cable	694
Figure 1-1282	Remove the cover	694
Figure 1-1283	Remove one screw	695
Figure 1-1284	Release one boss and one tab	695
Figure 1-1285	Remove the cover	696
Figure 1-1286	Remove the guide	696
Figure 1-1287	Remove two screws	697
Figure 1-1288	Disconnect one connector	697
Figure 1-1289	Remove the guide	697
Figure 1-1290	Remove three screws	698
Figure 1-1291	Remove the bracket	698
Figure 1-1292	Release the FFC	699
Figure 1-1293	Disconnect the FFC	699
Figure 1-1294	Recycle and unpack	700
Figure 1-1295	Connect one the FFC	700
Figure 1-1296	Adhere the FFC to the guide	701
Figure 1-1297	Install the bracket	701
Figure 1-1298	Install three screws	702
Figure 1-1299	Install the guide	702
Figure 1-1300	Connect one connector	702
Figure 1-1301	Install two screws	703
Figure 1-1302	Install the guide	703
Figure 1-1303	Install the cover	704

Figure 1-1304	Engage four bosses and tabs	704
Figure 1-1305	Engage one boss and one tab	705
Figure 1-1306	Install one screw	705
Figure 1-1307	Install the cover	706
Figure 1-1308	Engage four bosses	706
Figure 1-1309	Rotate the front edge of the cover down	707
Figure 1-1310	Install the USB PCA	707
Figure 1-1311	Install five screws	708
Figure 1-1312	Install the control-panel FFC cover	708
Figure 1-1313	Install the control-panel assembly	709
Figure 1-1314	Install two screws	709
Figure 1-1315	Remove one screw	710
Figure 1-1316	Install the cover	710
Figure 1-1317	Engage two tabs	711
Figure 1-1318	Install one screw	711
Figure 1-1319	Connect one connector	712
Figure 1-1320	Position the ISA on the printer	712
Figure 1-1321	Engage the hinge pins with the holders	713
Figure 1-1322	Rotate the ISA towards the front of the printer	713
Figure 1-1323	Pass the wire through the opening	714
Figure 1-1324	Install one screw	714
Figure 1-1325	Install the slider pin	715
Figure 1-1326	Secure the slider pin	715
Figure 1-1327	Connect three FFCs	716
Figure 1-1328	Install the ISA FFC cover	716
Figure 1-1329	Lower the ISA	717
Figure 1-1330	Install the cover	717
Figure 1-1331	Engage two bosses and one tab	718
Figure 1-1332	Check the power switch and cartridge door assembly button	718
Figure 1-1333	Install one screw	718
Figure 1-1334	Install the cover	719
Figure 1-1335	Engage three tabs and two bosses	719
Figure 1-1336	Install one screw	720
Figure 1-1337	Engage the left-side retainer arm	720
Figure 1-1338	Install the door	721
Figure 1-1339	Install the pressure-release link	721
Figure 1-1340	Install the guide	722
Figure 1-1341	Align the hinge	722
Figure 1-1342	Install the support shaft	723
Figure 1-1343	Install the tray	723
Figure 1-1344	Remove the tray	726

Figure 1-1345	Release the support shaft	726
Figure 1-1346	Remove the guide	727
Figure 1-1347	Remove the link arm	727
Figure 1-1348	Remove the door	728
Figure 1-1349	Release the left-side retainer arm	728
Figure 1-1350	Remove one screw	729
Figure 1-1351	Release two bosses and three tabs	729
Figure 1-1352	Remove the cover	730
Figure 1-1353	Remove one screw	730
Figure 1-1354	Release two bosses and three tabs	730
Figure 1-1355	Remove the cover	731
Figure 1-1356	Duplex models, lower the duplex feed assembly	731
Figure 1-1357	Remove two screws	732
Figure 1-1358	Raise the ISA	732
Figure 1-1359	Remove the ISA FFC cover	733
Figure 1-1360	Disconnect three FFCs	733
Figure 1-1361	Remove one screw	734
Figure 1-1362	Pass the wire through the opening	734
Figure 1-1363	Release one tab and rotate the slider pin	735
Figure 1-1364	Remove the slider pin	735
Figure 1-1365	Rotate the ISA towards the rear of the printer	736
Figure 1-1366	Release the ISA	736
Figure 1-1367	Remove the ISA	737
Figure 1-1368	Disconnect one connector	737
Figure 1-1369	Remove one screw	738
Figure 1-1370	Release two tabs	738
Figure 1-1371	Remove the cover	739
Figure 1-1372	Remove one screw	739
Figure 1-1373	Remove two screws	740
Figure 1-1374	Lift up the control-panel assembly	740
Figure 1-1375	Remove the control-panel assembly	741
Figure 1-1376	Remove the USB cable	741
Figure 1-1377	Remove the cover	742
Figure 1-1378	Remove one screw	742
Figure 1-1379	Release one boss and one tab	743
Figure 1-1380	Remove the cover	743
Figure 1-1381	Release two tabs	744
Figure 1-1382	Remove the guide	744
Figure 1-1383	Remove two screws	745
Figure 1-1384	Disconnect one connector	745
Figure 1-1385	Remove the guide	745

Figure 1-1386	Remove three screws	746
Figure 1-1387	Remove the bracket	746
Figure 1-1388	Disconnect three FFCs and six connectors	747
Figure 1-1389	Remove two screws	747
Figure 1-1390	Remove the DC controller	748
Figure 1-1391	Disconnect one the FFC	748
Figure 1-1392	Recycle and unpack	749
Figure 1-1393	Connect one the FFC	750
Figure 1-1394	Install the DC controller	750
Figure 1-1395	Connect three FFCs and six connectors	751
Figure 1-1396	Adhere the FFC to the guide	751
Figure 1-1397	Remove the guide	752
Figure 1-1398	Remove two screws	752
Figure 1-1399	Disconnect one connector	752
Figure 1-1400	Remove the guide	753
Figure 1-1401	Remove three screws	753
Figure 1-1402	Remove the bracket	753
Figure 1-1403	Engage two tabs	754
Figure 1-1404	Install the cover	754
Figure 1-1405	Engage four bosses and tabs	755
Figure 1-1406	Engage one boss and one tab	755
Figure 1-1407	Install one screw	756
Figure 1-1408	Install the cover	756
Figure 1-1409	Engage four bosses	757
Figure 1-1410	Rotate the front edge of the cover down	757
Figure 1-1411	Install the USB PCA	758
Figure 1-1412	Install five screws	758
Figure 1-1413	Install the control-panel FFC cover	759
Figure 1-1414	Install the control-panel assembly	759
Figure 1-1415	Install two screws	760
Figure 1-1416	Remove one screw	760
Figure 1-1417	Install the cover	761
Figure 1-1418	Engage two tabs	761
Figure 1-1419	Install one screw	762
Figure 1-1420	Connect one connector	762
Figure 1-1421	Position the ISA on the printer	763
Figure 1-1422	Engage the hinge pins with the holders	763
Figure 1-1423	Rotate the ISA towards the front of the printer	764
Figure 1-1424	Pass the wire through the opening	764
Figure 1-1425	Install one screw	765
Figure 1-1426	Install the slider pin	765

Figure 1-1427	Secure the slider pin	766
Figure 1-1428	Connect three FFCs	766
Figure 1-1429	Install the ISA FFC cover	767
Figure 1-1430	Lower the ISA	767
Figure 1-1431	Install the rear cover	768
Figure 1-1432	Install two screws	768
Figure 1-1433	Install the cover	769
Figure 1-1434	Engage two bosses and one tab	769
Figure 1-1435	Check the power switch and cartridge door assembly button	769
Figure 1-1436	Install one screw	770
Figure 1-1437	Install the cover	770
Figure 1-1438	Engage three tabs and two bosses	771
Figure 1-1439	Install one screw	771
Figure 1-1440	Engage the left-side retainer arm	772
Figure 1-1441	Install the door	772
Figure 1-1442	Install the pressure-release link	773
Figure 1-1443	Install the guide	773
Figure 1-1444	Align the hinge	774
Figure 1-1445	Install the support shaft	774
Figure 1-1446	Install the tray	775
Figure 1-1447	Remove the tray	777
Figure 1-1448	Release the support shaft	778
Figure 1-1449	Remove the guide	778
Figure 1-1450	Remove the link arm	779
Figure 1-1451	Remove the door	779
Figure 1-1452	Release the left-side retainer arm	780
Figure 1-1453	Remove one screw	780
Figure 1-1454	Release two bosses and three tabs	781
Figure 1-1455	Remove the cover	781
Figure 1-1456	Remove one screw	782
Figure 1-1457	Release two bosses and three tabs	782
Figure 1-1458	Remove the cover	782
Figure 1-1459	Raise the ISA	783
Figure 1-1460	Remove the ISA FFC cover	783
Figure 1-1461	Disconnect three FFCs	784
Figure 1-1462	Remove one screw	784
Figure 1-1463	Pass the wire through the opening	785
Figure 1-1464	Release one tab and rotate the slider pin	785
Figure 1-1465	Remove the slider pin	786
Figure 1-1466	Rotate the ISA towards the rear of the printer	786
Figure 1-1467	Release the ISA	787

Figure 1-1468	Remove the ISA	787
Figure 1-1469	Disconnect one connector	788
Figure 1-1470	Remove one screw	788
Figure 1-1471	Release two tabs	789
Figure 1-1472	Remove the cover	789
Figure 1-1473	Remove one screw	790
Figure 1-1474	Remove two screws	790
Figure 1-1475	Lift up the control-panel assembly	791
Figure 1-1476	Remove the control-panel assembly	791
Figure 1-1477	Remove the USB cable	792
Figure 1-1478	Remove the cover	792
Figure 1-1479	Remove one screw	793
Figure 1-1480	Release one boss and one tab	793
Figure 1-1481	Remove the cover	794
Figure 1-1482	Release two tabs	794
Figure 1-1483	Remove the guide	795
Figure 1-1484	Remove two screws	795
Figure 1-1485	Disconnect one connector	796
Figure 1-1486	Remove the guide	796
Figure 1-1487	Remove three screws	796
Figure 1-1488	Remove the bracket	797
Figure 1-1489	Disconnect one connector	797
Figure 1-1490	Remove one screw	798
Figure 1-1491	Remove the tag-cable assembly	798
Figure 1-1492	Recycle and unpack	799
Figure 1-1493	Install the assembly	799
Figure 1-1494	Install one screw	800
Figure 1-1495	Connect one connector	800
Figure 1-1496	Install the bracket	801
Figure 1-1497	Install three screws	801
Figure 1-1498	Install the guide	801
Figure 1-1499	Connect one connector	802
Figure 1-1500	Install two screws	802
Figure 1-1501	Install the guide	802
Figure 1-1502	Engage two tabs	803
Figure 1-1503	Install the cover	803
Figure 1-1504	Engage four bosses and tabs	804
Figure 1-1505	Engage one boss and one tab	804
Figure 1-1506	Install one screw	805
Figure 1-1507	Install the cover	805
Figure 1-1508	Engage four bosses	806

Figure 1-1509	Rotate the front edge of the cover down	806
Figure 1-1510	Install the USB PCA	807
Figure 1-1511	Install five screws	807
Figure 1-1512	Install the control-panel FFC cover	808
Figure 1-1513	Install the control-panel assembly	808
Figure 1-1514	Install two screws	809
Figure 1-1515	Remove one screw	809
Figure 1-1516	Install the cover	810
Figure 1-1517	Engage two tabs	810
Figure 1-1518	Install one screw	811
Figure 1-1519	Connect one connector	811
Figure 1-1520	Position the ISA on the printer	812
Figure 1-1521	Engage the hinge pins with the holders	812
Figure 1-1522	Rotate the ISA towards the front of the printer	813
Figure 1-1523	Pass the wire through the opening	813
Figure 1-1524	Install one screw	814
Figure 1-1525	Install the slider pin	814
Figure 1-1526	Secure the slider pin	815
Figure 1-1527	Connect three FFCs	815
Figure 1-1528	Install the ISA FFC cover	816
Figure 1-1529	Lower the ISA	816
Figure 1-1530	Install the cover	817
Figure 1-1531	Engage two bosses and one tab	817
Figure 1-1532	Check the power switch and cartridge door assembly button	817
Figure 1-1533	Install one screw	818
Figure 1-1534	Install the cover	818
Figure 1-1535	Engage three tabs and two bosses	819
Figure 1-1536	Install one screw	819
Figure 1-1537	Engage the left-side retainer arm	820
Figure 1-1538	Install the door	820
Figure 1-1539	Install the pressure-release link	821
Figure 1-1540	Install the guide	821
Figure 1-1541	Align the hinge	822
Figure 1-1542	Install the support shaft	822
Figure 1-1543	Install the tray	823
Figure 1-1544	Remove the tray	826
Figure 1-1545	Release the support shaft	826
Figure 1-1546	Remove the guide	827
Figure 1-1547	Remove the link arm	827
Figure 1-1548	Remove the door	828
Figure 1-1549	Release the left-side retainer arm	828

Figure 1-1550	Remove one screw	829
Figure 1-1551	Release two bosses and three tabs	829
Figure 1-1552	Remove the cover	830
Figure 1-1553	Remove one screw	830
Figure 1-1554	Release two bosses and three tabs	830
Figure 1-1555	Remove the cover	831
Figure 1-1556	Raise the ISA	831
Figure 1-1557	Remove the ISA FFC cover	832
Figure 1-1558	Disconnect three FFCs	832
Figure 1-1559	Remove one screw	833
Figure 1-1560	Pass the wire through the opening	833
Figure 1-1561	Release one tab and rotate the slider pin	834
Figure 1-1562	Remove the slider pin	834
Figure 1-1563	Rotate the ISA towards the rear of the printer	835
Figure 1-1564	Release the ISA	835
Figure 1-1565	Remove the ISA	836
Figure 1-1566	Disconnect one connector	836
Figure 1-1567	Remove one screw	837
Figure 1-1568	Release two tabs	837
Figure 1-1569	Remove the cover	838
Figure 1-1570	Remove one screw	838
Figure 1-1571	Remove two screws	839
Figure 1-1572	Lift up the control-panel assembly	839
Figure 1-1573	Remove the control-panel assembly	840
Figure 1-1574	Remove the USB cable	840
Figure 1-1575	Remove the cover	841
Figure 1-1576	Remove one screw	841
Figure 1-1577	Release one boss and one tab	842
Figure 1-1578	Remove the cover	842
Figure 1-1579	Release two tabs	843
Figure 1-1580	Remove the guide	843
Figure 1-1581	Remove two screws	844
Figure 1-1582	Disconnect one connector	844
Figure 1-1583	Remove the guide	844
Figure 1-1584	Remove three screws	845
Figure 1-1585	Remove the bracket	845
Figure 1-1586	Disconnect nine connectors	846
Figure 1-1587	Remove one screw	846
Figure 1-1588	Remove the connecting PCA	847
Figure 1-1589	Recycle and unpack	847
Figure 1-1590	Install the connecting PCA	848

Figure 1-1591	Install one screw	848
Figure 1-1592	Connect nine connectors	849
Figure 1-1593	Install the bracket	849
Figure 1-1594	Install three screws	850
Figure 1-1595	Install the guide	850
Figure 1-1596	Connect one connector	850
Figure 1-1597	Install two screws	851
Figure 1-1598	Install the guide	851
Figure 1-1599	Engage two tabs	852
Figure 1-1600	Install the cover	852
Figure 1-1601	Engage four bosses and tabs	853
Figure 1-1602	Engage one boss and one tab	853
Figure 1-1603	Install one screw	854
Figure 1-1604	Install the cover	854
Figure 1-1605	Engage four bosses	855
Figure 1-1606	Rotate the front edge of the cover down	855
Figure 1-1607	Install the USB PCA	856
Figure 1-1608	Install five screws	856
Figure 1-1609	Install the control-panel FFC cover	857
Figure 1-1610	Install the control-panel assembly	857
Figure 1-1611	Install two screws	858
Figure 1-1612	Remove one screw	858
Figure 1-1613	Install the cover	859
Figure 1-1614	Engage two tabs	859
Figure 1-1615	Install one screw	860
Figure 1-1616	Connect one connector	860
Figure 1-1617	Position the ISA on the printer	861
Figure 1-1618	Engage the hinge pins with the holders	861
Figure 1-1619	Rotate the ISA towards the front of the printer	862
Figure 1-1620	Pass the wire through the opening	862
Figure 1-1621	Install one screw	863
Figure 1-1622	Install the slider pin	863
Figure 1-1623	Secure the slider pin	864
Figure 1-1624	Connect three FFCs	864
Figure 1-1625	Install the ISA FFC cover	865
Figure 1-1626	Lower the ISA	865
Figure 1-1627	Install the cover	866
Figure 1-1628	Engage two bosses and one tab	866
Figure 1-1629	Check the power switch and cartridge door assembly button	866
Figure 1-1630	Install one screw	867
Figure 1-1631	Install the cover	867

Figure 1-1632	Engage three tabs and two bosses	868
Figure 1-1633	Install one screw	868
Figure 1-1634	Engage the left-side retainer arm	869
Figure 1-1635	Install the door	869
Figure 1-1636	Install the pressure-release link	870
Figure 1-1637	Install the guide	870
Figure 1-1638	Align the hinge	871
Figure 1-1639	Install the support shaft	871
Figure 1-1640	Install the tray	872
Figure 1-1641	Remove the tray	875
Figure 1-1642	Release the support shaft	875
Figure 1-1643	Remove the guide	876
Figure 1-1644	Remove the link arm	876
Figure 1-1645	Remove the door	877
Figure 1-1646	Release the left-side retainer arm	877
Figure 1-1647	Remove one screw	878
Figure 1-1648	Release two bosses and three tabs	878
Figure 1-1649	Remove the cover	879
Figure 1-1650	Remove one screw	879
Figure 1-1651	Release two bosses and three tabs	879
Figure 1-1652	Remove the cover	880
Figure 1-1653	Raise the ISA	880
Figure 1-1654	Remove the ISA FFC cover	881
Figure 1-1655	Disconnect three FFCs	881
Figure 1-1656	Remove one screw	882
Figure 1-1657	Pass the wire through the opening	882
Figure 1-1658	Release one tab and rotate the slider pin	883
Figure 1-1659	Remove the slider pin	883
Figure 1-1660	Rotate the ISA towards the rear of the printer	884
Figure 1-1661	Release the ISA	884
Figure 1-1662	Remove the ISA	885
Figure 1-1663	Disconnect one connector	885
Figure 1-1664	Remove one screw	886
Figure 1-1665	Release two tabs	886
Figure 1-1666	Remove the cover	887
Figure 1-1667	Remove one screw	887
Figure 1-1668	Remove two screws	888
Figure 1-1669	Lift up the control-panel assembly	888
Figure 1-1670	Remove the control-panel assembly	889
Figure 1-1671	Remove the USB cable	889
Figure 1-1672	Remove the cover	890

Figure 1-1673	Remove one screw	890
Figure 1-1674	Release one boss and one tab	891
Figure 1-1675	Remove the cover	891
Figure 1-1676	Release two tabs	892
Figure 1-1677	Remove the guide	892
Figure 1-1678	Remove two screws	893
Figure 1-1679	Disconnect one connector	893
Figure 1-1680	Remove the guide	893
Figure 1-1681	Remove three screws	894
Figure 1-1682	Remove the bracket	894
Figure 1-1683	Disconnect one connector	895
Figure 1-1684	Remove one screw	895
Figure 1-1685	Remove the tag-cable assembly	896
Figure 1-1686	Disconnect one FFC	896
Figure 1-1687	Remove one screw and the sheet-metal plate	897
Figure 1-1688	Disconnect one FFC	897
Figure 1-1689	Release the ferrite	898
Figure 1-1690	Remove the FFC	898
Figure 1-1691	Recycle and unpack	899
Figure 1-1692	Install the ferrite	899
Figure 1-1693	Install the FFC	900
Figure 1-1694	Connect one FFC	900
Figure 1-1695	Install the sheet-metal plate and install one screw	901
Figure 1-1696	Connect one FFC	901
Figure 1-1697	Install the assembly	902
Figure 1-1698	Install one screw	902
Figure 1-1699	Connect one connector	903
Figure 1-1700	Install the bracket	903
Figure 1-1701	Install three screws	904
Figure 1-1702	Install the guide	904
Figure 1-1703	Connect one connector	904
Figure 1-1704	Install two screws	905
Figure 1-1705	Install the guide	905
Figure 1-1706	Engage two tabs	906
Figure 1-1707	Install the cover	906
Figure 1-1708	Engage four bosses and tabs	907
Figure 1-1709	Engage one boss and one tab	907
Figure 1-1710	Install one screw	908
Figure 1-1711	Install the cover	908
Figure 1-1712	Engage four bosses	909
Figure 1-1713	Rotate the front edge of the cover down	909

Figure 1-1714	Install the USB PCA	910
Figure 1-1715	Install five screws	910
Figure 1-1716	Install the control-panel FFC cover	911
Figure 1-1717	Install the control-panel assembly	911
Figure 1-1718	Install two screws	912
Figure 1-1719	Remove one screw	912
Figure 1-1720	Install the cover	913
Figure 1-1721	Engage two tabs	913
Figure 1-1722	Install one screw	914
Figure 1-1723	Connect one connector	914
Figure 1-1724	Position the ISA on the printer	915
Figure 1-1725	Engage the hinge pins with the holders	915
Figure 1-1726	Rotate the ISA towards the front of the printer	916
Figure 1-1727	Pass the wire through the opening	916
Figure 1-1728	Install one screw	917
Figure 1-1729	Install the slider pin	917
Figure 1-1730	Secure the slider pin	918
Figure 1-1731	Connect three FFCs	918
Figure 1-1732	Install the ISA FFC cover	919
Figure 1-1733	Lower the ISA	919
Figure 1-1734	Install the cover	920
Figure 1-1735	Engage two bosses and one tab	920
Figure 1-1736	Check the power switch and cartridge door assembly button	920
Figure 1-1737	Install one screw	921
Figure 1-1738	Install the cover	921
Figure 1-1739	Engage three tabs and two bosses	922
Figure 1-1740	Install one screw	922
Figure 1-1741	Engage the left-side retainer arm	923
Figure 1-1742	Install the door	923
Figure 1-1743	Install the pressure-release link	924
Figure 1-1744	Install the guide	924
Figure 1-1745	Align the hinge	925
Figure 1-1746	Install the support shaft	925
Figure 1-1747	Install the tray	926
Figure 1-1748	Remove the tray	928
Figure 1-1749	Release the support shaft	929
Figure 1-1750	Remove the guide	929
Figure 1-1751	Remove the link arm	930
Figure 1-1752	Remove the door	930
Figure 1-1753	Release the left-side retainer arm	931
Figure 1-1754	Remove one screw	931

Figure 1-1755	Release two bosses and three tabs	932
Figure 1-1756	Remove the cover	932
Figure 1-1757	Remove one screw	933
Figure 1-1758	Release two bosses and three tabs	933
Figure 1-1759	Remove the cover	933
Figure 1-1760	Raise the ISA	934
Figure 1-1761	Remove the ISA FFC cover	934
Figure 1-1762	Disconnect three FFCs	935
Figure 1-1763	Remove one screw	935
Figure 1-1764	Pass the wire through the opening	936
Figure 1-1765	Release one tab and rotate the slider pin	936
Figure 1-1766	Remove the slider pin	937
Figure 1-1767	Rotate the ISA towards the rear of the printer	937
Figure 1-1768	Release the ISA	938
Figure 1-1769	Remove the ISA	938
Figure 1-1770	Disconnect one connector	939
Figure 1-1771	Remove one screw	939
Figure 1-1772	Release two tabs	940
Figure 1-1773	Remove the cover	940
Figure 1-1774	Remove one screw	941
Figure 1-1775	Remove two screws	941
Figure 1-1776	Lift up the control-panel assembly	942
Figure 1-1777	Remove the control-panel assembly	942
Figure 1-1778	Remove the USB cable	943
Figure 1-1779	Remove the cover	943
Figure 1-1780	Remove one screw	944
Figure 1-1781	Release one boss and one tab	944
Figure 1-1782	Remove the cover	945
Figure 1-1783	Release two tabs	945
Figure 1-1784	Remove the guide	946
Figure 1-1785	Remove two screws	946
Figure 1-1786	Disconnect one connector	947
Figure 1-1787	Remove the guide	947
Figure 1-1788	Remove three screws	947
Figure 1-1789	Remove the bracket	948
Figure 1-1790	Disconnect one FFC	948
Figure 1-1791	Disconnect one connector	949
Figure 1-1792	Remove two screws	949
Figure 1-1793	Release one tab	950
Figure 1-1794	Remove the HVPS	950
Figure 1-1795	Recycle and unpack	951

Figure 1-1796	Position the HVPS in the holder	951
Figure 1-1797	Engage one tab	952
Figure 1-1798	Install two screws	952
Figure 1-1799	Connect one connector	953
Figure 1-1800	Connect one FFC	953
Figure 1-1801	Install the bracket	954
Figure 1-1802	Install three screws	954
Figure 1-1803	Install the guide	954
Figure 1-1804	Connect one connector	955
Figure 1-1805	Install two screws	955
Figure 1-1806	Install the guide	955
Figure 1-1807	Engage two tabs	956
Figure 1-1808	Install the cover	956
Figure 1-1809	Engage four bosses and tabs	957
Figure 1-1810	Engage one boss and one tab	957
Figure 1-1811	Install one screw	958
Figure 1-1812	Install the cover	958
Figure 1-1813	Engage four bosses	959
Figure 1-1814	Rotate the front edge of the cover down	959
Figure 1-1815	Install the USB PCA	960
Figure 1-1816	Install five screws	960
Figure 1-1817	Install the control-panel FFC cover	961
Figure 1-1818	Install the control-panel assembly	961
Figure 1-1819	Install two screws	962
Figure 1-1820	Remove one screw	962
Figure 1-1821	Install the cover	963
Figure 1-1822	Engage two tabs	963
Figure 1-1823	Install one screw	964
Figure 1-1824	Connect one connector	964
Figure 1-1825	Position the ISA on the printer	965
Figure 1-1826	Engage the hinge pins with the holders	965
Figure 1-1827	Rotate the ISA towards the front of the printer	966
Figure 1-1828	Pass the wire through the opening	966
Figure 1-1829	Install one screw	967
Figure 1-1830	Install the slider pin	967
Figure 1-1831	Secure the slider pin	968
Figure 1-1832	Connect three FFCs	968
Figure 1-1833	Install the ISA FFC cover	969
Figure 1-1834	Lower the ISA	969
Figure 1-1835	Install the cover	970
Figure 1-1836	Engage two bosses and one tab	970

Figure 1-1837	Check the power switch and cartridge door assembly button	970
Figure 1-1838	Install one screw	971
Figure 1-1839	Install the cover	971
Figure 1-1840	Engage three tabs and two bosses	972
Figure 1-1841	Install one screw	972
Figure 1-1842	Engage the left-side retainer arm	973
Figure 1-1843	Install the door	973
Figure 1-1844	Install the pressure-release link	974
Figure 1-1845	Install the guide	974
Figure 1-1846	Align the hinge	975
Figure 1-1847	Install the support shaft	975
Figure 1-1848	Install the tray	976
Figure 1-1849	Remove the tray	979
Figure 1-1850	Release the support shaft	979
Figure 1-1851	Remove the guide	980
Figure 1-1852	Remove the link arm	980
Figure 1-1853	Remove the door	981
Figure 1-1854	Release the left-side retainer arm	981
Figure 1-1855	Remove one screw	982
Figure 1-1856	Release two bosses and three tabs	982
Figure 1-1857	Remove the cover	983
Figure 1-1858	Remove one screw	983
Figure 1-1859	Release two bosses and three tabs	983
Figure 1-1860	Remove the cover	984
Figure 1-1861	Raise the ISA	984
Figure 1-1862	Remove the ISA FFC cover	985
Figure 1-1863	Disconnect three FFCs	985
Figure 1-1864	Remove one screw	986
Figure 1-1865	Pass the wire through the opening	986
Figure 1-1866	Release one tab and rotate the slider pin	987
Figure 1-1867	Remove the slider pin	987
Figure 1-1868	Rotate the ISA towards the rear of the printer	988
Figure 1-1869	Release the ISA	988
Figure 1-1870	Remove the ISA	989
Figure 1-1871	Disconnect one connector	989
Figure 1-1872	Remove one screw	990
Figure 1-1873	Release two tabs	990
Figure 1-1874	Remove the cover	991
Figure 1-1875	Remove one screw	991
Figure 1-1876	Remove two screws	992
Figure 1-1877	Lift up the control-panel assembly	992

Figure 1-1878	Remove the control-panel assembly	993
Figure 1-1879	Remove the USB cable	993
Figure 1-1880	Remove the cover	994
Figure 1-1881	Remove one screw	994
Figure 1-1882	Release one boss and one tab	995
Figure 1-1883	Remove the cover	995
Figure 1-1884	Release two tabs	996
Figure 1-1885	Disconnect one connector	996
Figure 1-1886	Release two tabs	997
Figure 1-1887	Remove the fan	997
Figure 1-1888	Remove the guide	998
Figure 1-1889	Remove two screws	998
Figure 1-1890	Disconnect one connector	998
Figure 1-1891	Remove the guide	999
Figure 1-1892	Remove three screws	999
Figure 1-1893	Remove the bracket	999
Figure 1-1894	Disconnect two connectors	1000
Figure 1-1895	Remove one screw	1000
Figure 1-1896	Release one tab	1001
Figure 1-1897	Release one tab	1001
Figure 1-1898	Remove the holder	1002
Figure 1-1899	Remove two screws	1002
Figure 1-1900	Remove three screws	1003
Figure 1-1901	Remove the LVPS	1003
Figure 1-1902	Recycle and unpack	1004
Figure 1-1903	Install the LVPS	1004
Figure 1-1904	Install three screws	1005
Figure 1-1905	Install two screws	1005
Figure 1-1906	Install the holder	1006
Figure 1-1907	Engage one tab	1006
Figure 1-1908	Engage one tab	1007
Figure 1-1909	Install one screw	1007
Figure 1-1910	Connect two connectors	1008
Figure 1-1911	Install the bracket	1008
Figure 1-1912	Install three screws	1009
Figure 1-1913	Install the guide	1009
Figure 1-1914	Connect one connector	1009
Figure 1-1915	Install two screws	1010
Figure 1-1916	Install the guide	1010
Figure 1-1917	Install the fan	1011
Figure 1-1918	Connect one connector	1011

Figure 1-1919	Engage two tabs	1012
Figure 1-1920	Install the cover	1012
Figure 1-1921	Engage four bosses and tabs	1013
Figure 1-1922	Engage one boss and one tab	1013
Figure 1-1923	Install one screw	1014
Figure 1-1924	Install the cover	1014
Figure 1-1925	Engage four bosses	1015
Figure 1-1926	Rotate the front edge of the cover down	1015
Figure 1-1927	Install the USB PCA	1016
Figure 1-1928	Install five screws	1016
Figure 1-1929	Install the control-panel FFC cover	1017
Figure 1-1930	Install the control-panel assembly	1017
Figure 1-1931	Install two screws	1018
Figure 1-1932	Remove one screw	1018
Figure 1-1933	Install the cover	1019
Figure 1-1934	Engage two tabs	1019
Figure 1-1935	Install one screw	1020
Figure 1-1936	Connect one connector	1020
Figure 1-1937	Position the ISA on the printer	1021
Figure 1-1938	Engage the hinge pins with the holders	1021
Figure 1-1939	Rotate the ISA towards the front of the printer	1022
Figure 1-1940	Pass the wire through the opening	1022
Figure 1-1941	Install one screw	1023
Figure 1-1942	Install the slider pin	1023
Figure 1-1943	Secure the slider pin	1024
Figure 1-1944	Connect three FFCs	1024
Figure 1-1945	Install the ISA FFC cover	1025
Figure 1-1946	Lower the ISA	1025
Figure 1-1947	Install the cover	1026
Figure 1-1948	Engage two bosses and one tab	1026
Figure 1-1949	Check the power switch and cartridge door assembly button	1026
Figure 1-1950	Install one screw	1027
Figure 1-1951	Install the cover	1027
Figure 1-1952	Engage three tabs and two bosses	1028
Figure 1-1953	Install one screw	1028
Figure 1-1954	Engage the left-side retainer arm	1029
Figure 1-1955	Install the door	1029
Figure 1-1956	Install the pressure-release link	1030
Figure 1-1957	Install the guide	1030
Figure 1-1958	Align the hinge	1031
Figure 1-1959	Install the support shaft	1031

Figure 1-1960	Install the tray	1032
Figure 1-1961	Remove the tray	1034
Figure 1-1962	Release the support shaft	1035
Figure 1-1963	Remove the guide	1035
Figure 1-1964	Remove the link arm	1036
Figure 1-1965	Remove the door	1036
Figure 1-1966	Release the left-side retainer arm	1037
Figure 1-1967	Remove one screw	1037
Figure 1-1968	Release two bosses and three tabs	1038
Figure 1-1969	Remove the cover	1038
Figure 1-1970	Remove one screw	1039
Figure 1-1971	Release two bosses and three tabs	1039
Figure 1-1972	Remove the cover	1039
Figure 1-1973	Raise the ISA	1040
Figure 1-1974	Remove the ISA FFC cover	1040
Figure 1-1975	Disconnect three FFCs	1041
Figure 1-1976	Remove one screw	1041
Figure 1-1977	Pass the wire through the opening	1042
Figure 1-1978	Release one tab and rotate the slider pin	1042
Figure 1-1979	Remove the slider pin	1043
Figure 1-1980	Rotate the ISA towards the rear of the printer	1043
Figure 1-1981	Release the ISA	1044
Figure 1-1982	Remove the ISA	1044
Figure 1-1983	Disconnect one connector	1045
Figure 1-1984	Remove one screw	1045
Figure 1-1985	Release two tabs	1046
Figure 1-1986	Remove the cover	1046
Figure 1-1987	Remove one screw	1047
Figure 1-1988	Remove two screws	1047
Figure 1-1989	Lift up the control-panel assembly	1048
Figure 1-1990	Remove the control-panel assembly	1048
Figure 1-1991	Remove the USB cable	1049
Figure 1-1992	Remove the cover	1049
Figure 1-1993	Remove the cover	1050
Figure 1-1994	Recycle and unpack	1050
Figure 1-1995	Remove the cover	1051
Figure 1-1996	Install the cover	1051
Figure 1-1997	Engage four bosses	1052
Figure 1-1998	Rotate the front edge of the cover down	1052
Figure 1-1999	Install the USB PCA	1053
Figure 1-2000	Install five screws	1053

Figure 1-2001	Install the control-panel FFC cover	1054
Figure 1-2002	Install the control-panel assembly	1054
Figure 1-2003	Install two screws	1055
Figure 1-2004	Remove one screw	1055
Figure 1-2005	Install the cover	1056
Figure 1-2006	Engage two tabs	1056
Figure 1-2007	Install one screw	1057
Figure 1-2008	Connect one connector	1057
Figure 1-2009	Position the ISA on the printer	1058
Figure 1-2010	Engage the hinge pins with the holders	1058
Figure 1-2011	Rotate the ISA towards the front of the printer	1059
Figure 1-2012	Pass the wire through the opening	1059
Figure 1-2013	Install one screw	1060
Figure 1-2014	Install the slider pin	1060
Figure 1-2015	Secure the slider pin	1061
Figure 1-2016	Connect three FFCs	1061
Figure 1-2017	Install the ISA FFC cover	1062
Figure 1-2018	Lower the ISA	1062
Figure 1-2019	Install the cover	1063
Figure 1-2020	Engage two bosses and one tab	1063
Figure 1-2021	Check the power switch and cartridge door assembly button	1063
Figure 1-2022	Install one screw	1064
Figure 1-2023	Install the cover	1064
Figure 1-2024	Engage three tabs and two bosses	1065
Figure 1-2025	Install one screw	1065
Figure 1-2026	Engage the left-side retainer arm	1066
Figure 1-2027	Install the door	1066
Figure 1-2028	Install the pressure-release link	1067
Figure 1-2029	Install the guide	1067
Figure 1-2030	Align the hinge	1068
Figure 1-2031	Install the support shaft	1068
Figure 1-2032	Install the tray	1069
Figure 1-2033	Remove the tray	1071
Figure 1-2034	Release the support shaft	1072
Figure 1-2035	Remove the guide	1072
Figure 1-2036	Remove the link arm	1073
Figure 1-2037	Remove the door	1073
Figure 1-2038	Release the left-side retainer arm	1074
Figure 1-2039	Remove one screw	1074
Figure 1-2040	Release two bosses and three tabs	1075
Figure 1-2041	Remove the cover	1075

Figure 1-2042	Remove one screw	1076
Figure 1-2043	Release two bosses and three tabs	1076
Figure 1-2044	Remove the cover	1076
Figure 1-2045	Raise the ISA	1077
Figure 1-2046	Remove the ISA FFC cover	1077
Figure 1-2047	Disconnect three FFCs	1078
Figure 1-2048	Remove one screw	1078
Figure 1-2049	Pass the wire through the opening	1079
Figure 1-2050	Release one tab and rotate the slider pin	1079
Figure 1-2051	Remove the slider pin	1080
Figure 1-2052	Rotate the ISA towards the rear of the printer	1080
Figure 1-2053	Release the ISA	1081
Figure 1-2054	Remove the ISA	1081
Figure 1-2055	Disconnect one connector	1082
Figure 1-2056	Remove one screw	1082
Figure 1-2057	Release two tabs	1083
Figure 1-2058	Remove the cover	1083
Figure 1-2059	Remove one screw	1084
Figure 1-2060	Remove two screws	1084
Figure 1-2061	Lift up the control-panel assembly	1085
Figure 1-2062	Remove the control-panel assembly	1085
Figure 1-2063	Remove the USB cable	1086
Figure 1-2064	Remove the cover	1086
Figure 1-2065	Remove the cover	1087
Figure 1-2066	Remove one screw	1087
Figure 1-2067	Release one boss and one tab	1088
Figure 1-2068	Remove the cover	1088
Figure 1-2069	Remove one screw	1089
Figure 1-2070	Remove the NFC PCA	1089
Figure 1-2071	Recycle and unpack	1090
Figure 1-2072	Connect one FFC	1090
Figure 1-2073	Install the NFC PCA	1091
Figure 1-2074	Install one screw	1091
Figure 1-2075	Install the cover	1092
Figure 1-2076	Engage four bosses and tabs	1092
Figure 1-2077	Engage one boss and one tab	1093
Figure 1-2078	Install one screw	1093
Figure 1-2079	Remove the cover	1094
Figure 1-2080	Install the cover	1094
Figure 1-2081	Engage four bosses	1095
Figure 1-2082	Rotate the front edge of the cover down	1095

Figure 1-2083	Install the USB PCA	1096
Figure 1-2084	Install five screws	1096
Figure 1-2085	Install the control-panel FFC cover	1097
Figure 1-2086	Install the control-panel assembly	1097
Figure 1-2087	Install two screws	1098
Figure 1-2088	Remove one screw	1098
Figure 1-2089	Install the cover	1099
Figure 1-2090	Engage two tabs	1099
Figure 1-2091	Install one screw	1100
Figure 1-2092	Connect one connector	1100
Figure 1-2093	Position the ISA on the printer	1101
Figure 1-2094	Engage the hinge pins with the holders	1101
Figure 1-2095	Rotate the ISA towards the front of the printer	1102
Figure 1-2096	Pass the wire through the opening	1102
Figure 1-2097	Install one screw	1103
Figure 1-2098	Install the slider pin	1103
Figure 1-2099	Secure the slider pin	1104
Figure 1-2100	Connect three FFCs	1104
Figure 1-2101	Install the ISA FFC cover	1105
Figure 1-2102	Lower the ISA	1105
Figure 1-2103	Install the cover	1106
Figure 1-2104	Engage two bosses and one tab	1106
Figure 1-2105	Check the power switch and cartridge door assembly button	1106
Figure 1-2106	Install one screw	1107
Figure 1-2107	Install the cover	1107
Figure 1-2108	Engage three tabs and two bosses	1108
Figure 1-2109	Install one screw	1108
Figure 1-2110	Engage the left-side retainer arm	1109
Figure 1-2111	Install the door	1109
Figure 1-2112	Install the pressure-release link	1110
Figure 1-2113	Install the guide	1110
Figure 1-2114	Align the hinge	1111
Figure 1-2115	Install the support shaft	1111
Figure 1-2116	Install the tray	1112
Figure 1-2117	Remove the tray	1114
Figure 1-2118	Release the support shaft	1115
Figure 1-2119	Remove the guide	1115
Figure 1-2120	Remove the link arm	1116
Figure 1-2121	Remove the door	1116
Figure 1-2122	Release the left-side retainer arm	1117
Figure 1-2123	Remove one screw	1117

Figure 1-2124	Release two bosses and three tabs	1118
Figure 1-2125	Remove the cover	1118
Figure 1-2126	Remove one screw	1119
Figure 1-2127	Release two bosses and three tabs	1119
Figure 1-2128	Remove the cover	1119
Figure 1-2129	Remove one screw	1120
Figure 1-2130	Release one boss and one tab	1120
Figure 1-2131	Remove the cover	1121
Figure 1-2132	Release two tabs	1121
Figure 1-2133	Disconnect one FFC	1122
Figure 1-2134	Remove one screw and the control panel	1122
Figure 1-2135	Recycle and unpack	1123
Figure 1-2136	Install the control panel and one screw	1123
Figure 1-2137	Connect one FFC	1124
Figure 1-2138	Engage two tabs	1124
Figure 1-2139	Install the cover	1125
Figure 1-2140	Engage four bosses and tabs	1125
Figure 1-2141	Engage one boss and one tab	1126
Figure 1-2142	Install one screw	1126
Figure 1-2143	Install the cover	1127
Figure 1-2144	Engage two bosses and one tab	1127
Figure 1-2145	Check the power switch and cartridge door assembly button	1127
Figure 1-2146	Install one screw	1128
Figure 1-2147	Install the cover	1128
Figure 1-2148	Engage three tabs and two bosses	1129
Figure 1-2149	Install one screw	1129
Figure 1-2150	Engage the left-side retainer arm	1130
Figure 1-2151	Install the door	1130
Figure 1-2152	Install the pressure-release link	1131
Figure 1-2153	Install the guide	1131
Figure 1-2154	Align the hinge	1132
Figure 1-2155	Install the support shaft	1132
Figure 1-2156	Install the tray	1133
Figure 1-2157	Open the ISA	1136
Figure 1-2158	Remove one screw	1136
Figure 1-2159	Release two tabs	1137
Figure 1-2160	Remove the cover	1137
Figure 1-2161	Remove one screw	1138
Figure 1-2162	Tilt the control panel farther forward	1138
Figure 1-2163	Release the control panel	1139
Figure 1-2164	Separate the control panel from the printer	1139

Figure 1-2165	Release the FFC and remove the control panel	1140
Figure 1-2166	Remove two screws	1140
Figure 1-2167	Remove the FFC	1141
Figure 1-2168	Release the control panel mount base	1141
Figure 1-2169	Release the mount chassis assembly	1142
Figure 1-2170	Remove the mount chassis assembly	1142
Figure 1-2171	Remove the tray	1143
Figure 1-2172	Release the support shaft	1143
Figure 1-2173	Remove the guide	1144
Figure 1-2174	Remove the link arm	1144
Figure 1-2175	Remove the door	1145
Figure 1-2176	Release the left-side retainer arm	1145
Figure 1-2177	Remove one screw	1146
Figure 1-2178	Release two bosses and three tabs	1146
Figure 1-2179	Remove the cover	1147
Figure 1-2180	Remove the ISA FFC cover	1147
Figure 1-2181	Disconnect one FFC	1148
Figure 1-2182	Release the control-panel FFC cover	1148
Figure 1-2183	Remove the cover and FFC	1149
Figure 1-2184	Remove the FFC	1149
Figure 1-2185	Recycle and unpack	1150
Figure 1-2186	Install the FFC on the cover	1150
Figure 1-2187	Install the cover	1151
Figure 1-2188	Connect one FFC	1151
Figure 1-2189	Install the ISA FFC cover	1152
Figure 1-2190	Install the cover	1152
Figure 1-2191	Engage three tabs and two bosses	1153
Figure 1-2192	Install one screw	1153
Figure 1-2193	Engage the left-side retainer arm	1154
Figure 1-2194	Install the door	1154
Figure 1-2195	Install the pressure-release link	1155
Figure 1-2196	Install the guide	1155
Figure 1-2197	Align the hinge	1156
Figure 1-2198	Install the support shaft	1156
Figure 1-2199	Install the tray	1157
Figure 1-2200	Install the mount chassis assembly	1157
Figure 1-2201	Release the mount chassis assembly	1158
Figure 1-2202	Install the control panel mount base	1158
Figure 1-2203	Install two screws	1159
Figure 1-2204	Install the FFC	1159
Figure 1-2205	Connect the FFC	1160

Figure 1-2206	Align the control-panel hinge pins	1160
Figure 1-2207	Engage the control panel	1161
Figure 1-2208	Tilt the control-panel assembly backward	1162
Figure 1-2209	Install one screw	1162
Figure 1-2210	Install the control-panel cable cover	1163
Figure 1-2211	Check two tabs	1163
Figure 1-2212	Install one screw	1164
Figure 1-2213	Close the ISA	1164
Figure 1-2214	Remove the tray	1167
Figure 1-2215	Recycle and unpack	1167
Figure 1-2216	Install the tray	1168
Figure 1-2217	Remove the tray	1169
Figure 1-2218	Tilt the printer backward	1170
Figure 1-2219	Place the printer bottom-side face forward	1170
Figure 1-2220	Release one tab	1171
Figure 1-2221	Remove the roller holder	1171
Figure 1-2222	Recycle and unpack	1172
Figure 1-2223	Install the roller holder	1172
Figure 1-2224	Check the tab	1173
Figure 1-2225	Rotate the printer forward	1173
Figure 1-2226	Place the printer in the operational position	1174
Figure 1-2227	Install the tray	1174
Figure 1-2228	Remove the tray	1176
Figure 1-2229	Release the assembly	1176
Figure 1-2230	Remove the assembly	1177
Figure 1-2231	Recycle and unpack	1177
Figure 1-2232	Install the assembly	1178
Figure 1-2233	Release the assembly	1178
Figure 1-2234	Install the tray	1179
Figure 1-2235	Remove the printer	1182
Figure 1-2236	Recycle and unpack	1182
Figure 1-2237	Remove shipping tape	1183
Figure 1-2238	Install the printer	1183
Figure 1-2239	Remove Tray 3	1184
Figure 1-2240	Adjust the paper guides	1184
Figure 1-2241	Load paper	1185
Figure 1-2242	Install	1185
Figure 1-2243	Pull the tray out of the printer	1187
Figure 1-2244	Release and remove the tray	1187
Figure 1-2245	Recycle and unpack	1188
Figure 1-2246	Install the tray	1188

Figure 1-2247	Close the tray	1189
Figure 1-2248	Pull the tray out of the printer	1191
Figure 1-2249	Release and remove the tray	1191
Figure 1-2250	Turn the accessory over	1192
Figure 1-2251	Release the assembly	1192
Figure 1-2252	Rotate the assembly up	1193
Figure 1-2253	Remove the assembly	1193
Figure 1-2254	Recycle and unpack	1194
Figure 1-2255	Install the roller assembly	31
Figure 1-2256	Release the assembly	1195
Figure 1-2257	Check the installation	1195
Figure 1-2258	Install the tray	1196
Figure 1-2259	Close the tray	1196
Figure 1-2260	Pull the tray out of the printer	1198
Figure 1-2261	Release and remove the tray	1198
Figure 1-2262	Release the assembly	1199
Figure 1-2263	Remove the assembly	1199
Figure 1-2264	Recycle and unpack	1200
Figure 1-2265	Install the assembly	1200
Figure 1-2266	Release the assembly	1201
Figure 1-2267	Install the tray	1201
Figure 1-2268	Close the tray	1202
Figure 2-1	Main assemblies (document feeder and image scanner)	1208
Figure 2-2	Covers, M402 and M403	1210
Figure 2-3	Covers, M426 and M427	1212
Figure 2-4	Internal components, printer base (1 of 5)	1214
Figure 2-5	Internal components, printer base (2 of 3)	1216
Figure 2-6	Internal components, printer base (3 of 3)	1218
Figure 2-7	Covers, 550-sheet paper feeder	1220
Figure 2-8	Main body, 550-sheet paper feeder	1222

1 Removal and replacement

- [For additional service and support](#)
- [Removal and replacement strategy](#)
- [Service approach](#)
- [Removal and replacement procedures](#)

For additional service and support

HP service personnel, go to the Service Access Work Bench (SAW) at <http://h41302.www4.hp.com/km/saw/home.do>.

Channel partners, go to HP Channel Services Network (CSN) at <https://h30125.www3.hp.com/hpcsn>.

At these locations, find information on the following topics:

- Install and configure
- Printer specifications
- Up-to-date control panel message (CPMD) troubleshooting
- Solutions for printer issues and emerging issues
- Remove and replace part instructions and videos
- Service advisories
- Warranty and regulatory information

To access HP PartSurfer information from any mobile device, go to <http://partsurfermobile.hp.com/> or scan the Quick Response (QR) code below.



Removal and replacement strategy

Introduction

The printer uses a field repair strategy. Defective parts are diagnosed and replaced at the Field Replaceable Unit (FRU) assembly level. Repair normally begins by using the printer internal diagnostics and the following two-step process:

1. Isolate the problem to the major system (for example, the network, server, or printer).
2. Identify the cause of failures according to the printer troubleshooting service manual and follow the disassembly procedures to replace the defective parts or the consumable parts.

After locating a faulty part, the printer can usually be repaired at the assembly level by replacing FRUs. Some mechanical assemblies might need to be repaired at the subassembly level. HP does not support replacement of components on the printed circuit assemblies.

The user replaces toner cartridges as they are depleted. Additional instructions about other user-replaceable parts are provided in this section.

The printer tracks the amount of use on the customer-replaceable supplies by keeping a page count. The printer prompts the user to replace certain items when a supply is depleted or a specific number of pages has been printed.

Swapping toner cartridges between products might cause a misrepresentation of supply life values and is not recommended.

Considerations during removal and replacement

This chapter describes the removal and replacement of FRUs only.

Replacing FRUs is generally the reverse of removal. Notes are included to provide directions for difficult or critical replacement procedures.

HP does not support repairing individual subassemblies or troubleshooting to the printed-circuit assembly (PCA) component level.

 **WARNING!** Never operate or service the printer with the protective cover removed from the laser scanner assembly. The reflected beam, although invisible, can cause damage to the eyes.

The sheet-metal parts can have sharp edges. Be careful when handling sheet-metal parts.

Before attempting to remove or replace parts, turn the printer off and remove the power cable. Never operate the printer with the parts removed from the printer.

Turn the printer off, wait 5 seconds, and then remove the power cord before attempting to service the printer. *If this warning is not followed, severe injury can result as well as damage to the printer.* The power must be on for certain functional checks during troubleshooting. However, the power cord must be disconnected during parts removal. AC voltage is still present inside the printer when the power switch is in the off position. The power cord must be *disconnected* before servicing the printer.

 **CAUTION:** Incorrectly routed or loose wire harnesses might interfere with other internal components or assemblies and be damaged, pinched, or frayed. Make sure that wire harnesses are correctly routed and retained when installing assemblies.

Do not bend or fold the flat flexible cables (FFCs) during removal or installation. Do not straighten pre-folds in the FFCs.

Do not expose the toner cartridge, or cartridges, to strong light even for a short time.

 **IMPORTANT:** When an assembly is removed that includes a rating plate or tag (or a printer code label), make sure to transfer the plate or tag (or code label) to the replacement assembly.

Do not replace the formatter and DC controller simultaneously during a single printer servicing. Doing so might cause the printer to become unstable or inoperable.

During removal, replacement, or transportation of the printer, remove the cassettes.

Incorrectly routed or loose wire harnesses can interfere with other internal components and can become damaged or broken.

 **NOTE:** During assembly removal and replacement, or if the printer is moved, remove the toner cartridge.

Toner is a non-poisonous substance composed of plastic and a small number of colored components. If toner gets on the skin or clothing, wipe it off with dry tissue paper and wash in cold water. Hot water sets toner and it might be difficult, or impossible, to remove. Toner easily breaks down vinyl materials, so avoid letting toner contact vinyl.



Reassembling procedures are generally the reverse of removal unless otherwise specified. Occasionally, notes and tips are included to provide directions for difficult or critical replacement procedures.

Note the length, diameter, color, type, and location of each screw. Be sure to return each screw to its original location during reassembly.

To install a self-tapping screw, first turn it counterclockwise to align it with the existing thread pattern, and then carefully turn it clockwise to tighten. Do not overtighten. If a self-tapping screw hole becomes stripped, repair the screw-hole or replace the affected assembly.

 **TIP:** Some figures might show assemblies removed or installed that have not yet been removed or installed at that specific step. However, the procedures are correct for this printer and the target assembly. Always thoroughly read the instructions that accompany each figure.

Electrostatic discharge

 **CAUTION:**  Some parts are sensitive to electrostatic discharge (ESD). Look for the ESD reminder when removing printer parts. Always perform service work at an ESD-protected workstation or mat. If an ESD workstation or mat is not available, touch the sheet-metal chassis to provide a static ground *before* touching an ESD-sensitive assembly.

Protect the ESD-sensitive assemblies by placing them in ESD pouches when they are out of the printer.

Required tools

- #2 Phillips screwdriver with a magnetic tip and a 152 mm (6 in) shaft length
- Small, flat-blade screwdriver
- Socket screwdriver 5.5 mm (.216 in) shaft length

- Needle-nose pliers
- ESD strap (if one is available)
- Penlight

⚠ CAUTION: Always use a Phillips screwdriver (callout 1). Do not use a Pozidriv screwdriver (callout 2) or any motorized screwdriver. These can damage screws or screw threads.

Figure 1-1 Screwdrivers

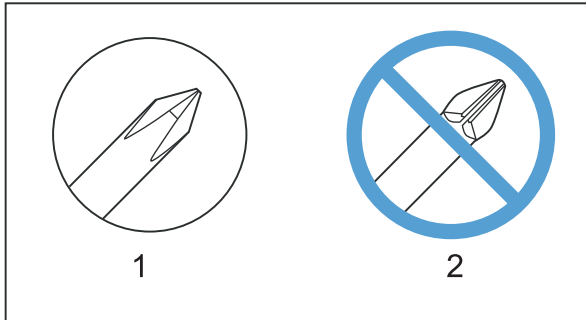

Fasteners used in this printer

⚠ WARNING! Make sure that assemblies are replaced with the correct screw type. Using the incorrect screw (for example, substituting a long screw for the correct shorter screw) can cause damage to the printer or interfere with printer operation. Do not intermix screws that are removed from one assembly with the screws that are removed from another assembly.

📝 NOTE: To install a self-tapping screw, first turn it counterclockwise to align it with the existing thread pattern, and then carefully turn it clockwise to tighten. Do not overtighten. If a self-tapping screw hole becomes stripped, repair the screw hole or replace the affected assembly.

Always take note of the length, diameter, color, type, and location of each removed screw. Make sure that screws are installed in the original location they were removed from during reinstallation.

For a complete list of screw types and part numbers, see the Parts chapter.

Service approach

Before performing service

- Remove all paper from the product.
- Turn off the power using the power switch.
- Unplug the power cable and interface cable or cables.
- Place the product on an ESD workstation or mat, or use an ESD strap (if one is available). If an ESD workstation, mat, or strap is not available, ground yourself by touching the sheet-metal chassis *before* touching an ESD-sensitive part.
- Remove the toner cartridge.
- Remove the Tray 2 cassette.

After performing service

1. Reinstall the toner cartridge or toner cartridges.
2. Reinstall the trays.
3. Return all paper to the trays.
4. Plug in the power cable and turn on the printer.
5. Perform print-quality tests by printing from a host computer.

Post-service test

Perform the following test to verify that the repair or replacement was successful.

Print-quality test

1. Verify that you have completed the necessary reassembly steps.
2. Make sure that the tray contains clean, unmarked paper.
3. Attach the power cord and interface cable or interface cables, and then turn on the product.
4. Verify that the expected startup sounds occur.
5. Print a configuration page, and then verify that the expected printing sounds occur.
6. Print a demo page, and then verify that the print quality is as expected.
7. Send a print job from the host computer, and then verify that the output meets expectations.
8. Clean the outside of the product with a damp cloth.

Removal and replacement procedures

Customer self-repair (CSR) A parts and assemblies

The CSR level indicates the expected difficulty the customer will experience when removing and replacing an assembly. The CSR A assemblies in this section are easy for the customer to remove and replace.

- [RL2-0656-000CN multipurpose tray roller](#)
- [RM2-5392-000CN 250-sheet paper input tray](#)
- [RM2-5413-000CN optional Tray 3](#)
- [RM2-5452-000CN Tray 2 paper pickup roller assembly](#)
- [RM2-5741-000CN optional Tray 3 paper pickup roller assembly](#)
- [RM2-5397-000CN Tray 2 separation roller assembly](#)
- [RM2-5745-000CN optional Tray 3 separation roller assembly](#)

RL2-0656-000CN multipurpose tray roller

- [Introduction](#)
- [Step 1: Remove the roller](#)
- [Step 2: Unpack the replacement assembly](#)
- [Step 3: Install the roller](#)

Introduction

This document provides the procedures to remove and replace the Multipurpose (MP) tray (Tray 1) roller.

Before performing service

Turn the printer power off

- Disconnect the power cable.

 **WARNING!** To avoid damage to the printer, turn the printer off, wait 30 seconds, and then remove the power cable before attempting to service the printer.

Use the table below to identify the correct part number for your printer. To order the part, go to www.hp.com/buy/parts.

MP tray (Tray 1) roller part number	
RL2-0655-000CN	Roller, MP tray (Tray 1)

Required tools

- No special tools are required to remove this part.

After performing service

Turn the printer power on

- Connect the power cable.
- Use the power switch to turn the power on.

Post service test

Make sure that the printer initializes to a **Ready** state.

Print a page from Tray 1 to make sure that the printer is functioning correctly.

Step 1: Remove the roller

The M427/M426 printer is shown in this procedure. However, the instructions are valid for the M403/M402 printers.

1. Press the door-release button, and then open the toner-cartridge door.

Figure 1-2 Open the toner-cartridge door



2. Release two tabs between the roller collar and roller, and then rotate the top of the roller out and away from the printer.

 **TIP:** Pushing down on the top of the roller might make it easier to release the tabs.

Figure 1-3 Release two tabs



3. Remove the roller.

Figure 1-4 Remove the roller

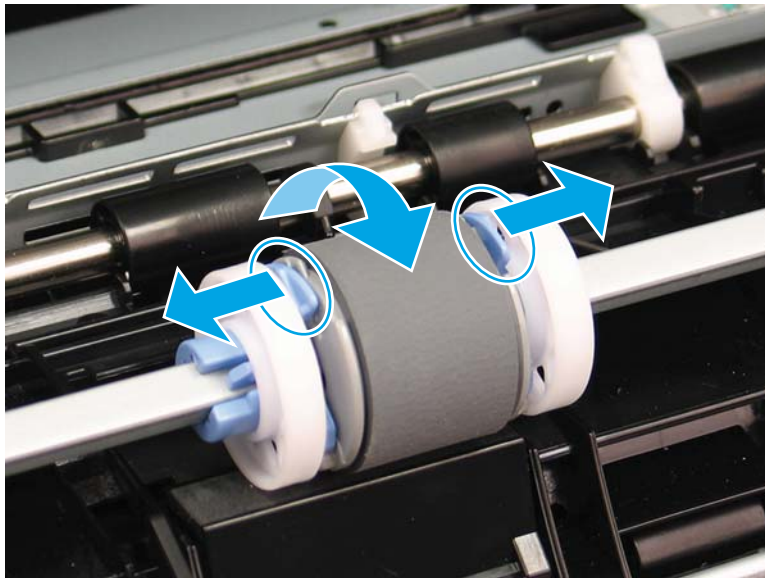
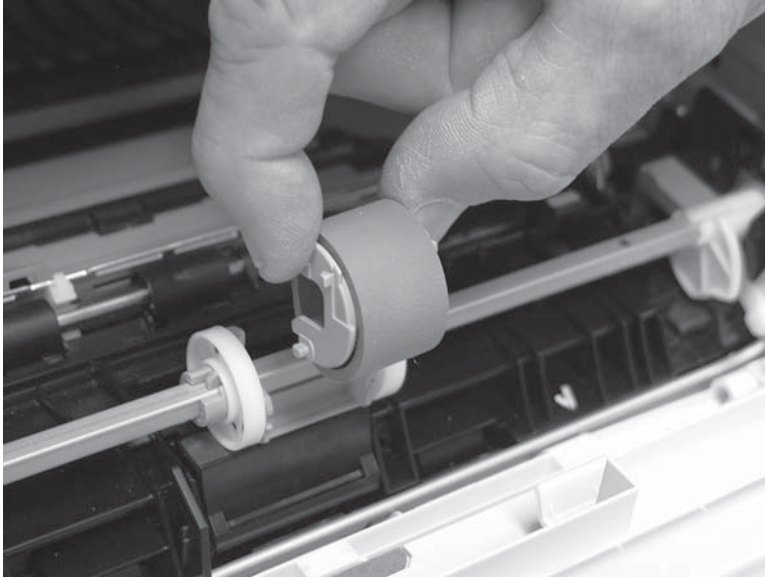

Step 2: Unpack the replacement assembly

Unpack the replacement part from the packaging.

<http://www8.hp.com/us/en/hp-information/environment/product-recycling.html>

CAUTION: Do not touch the gray spongy portion of the replacement roller. Skin oils on the roller can cause paper handling problems.

NOTE: HP recommends responsible disposal of the defective part.

Figure 1-5 Recycle and unpack

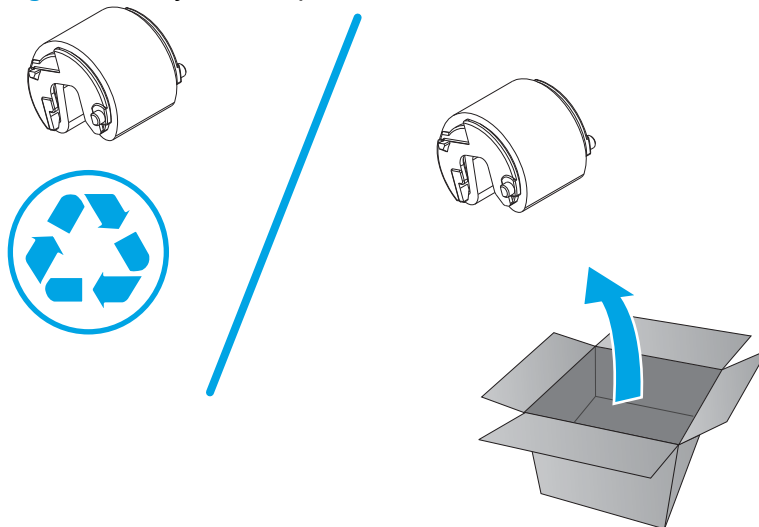

Step 3: Install the roller

CAUTION: Do not touch the gray spongy portion of the replacement roller. Skin oils on the roller can cause paper handling problems.

The M427/M426 printer is shown in this procedure. However, the instructions are valid for the M403/M402 printers.

1. Position the replacement pickup roller with the pins in the provided slots on the holder, and then rotate the top of the roller up and toward the printer.

Figure 1-6 Install the roller

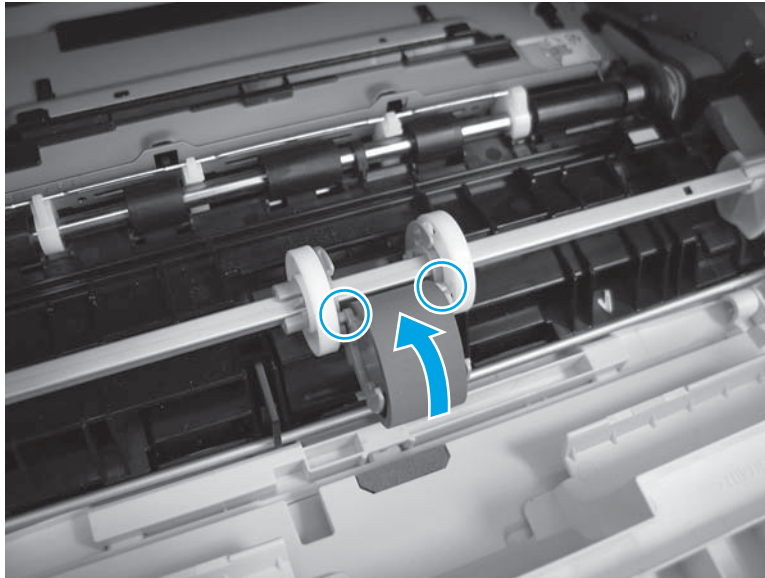

2. Continue to rotate the top of the roller toward the printer (callout 1), until two tabs (callout 2) snap into place.

Figure 1-7 Engage two tabs

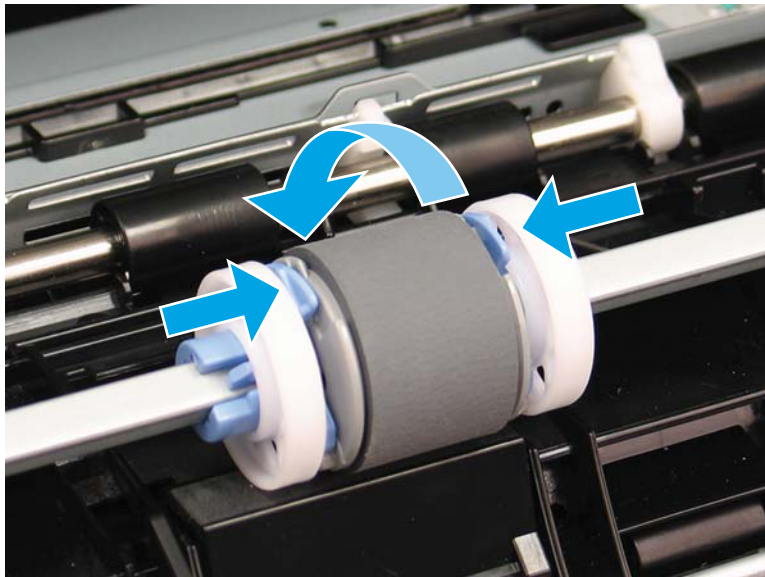

3. Close the toner-cartridge door.

Figure 1-8 Close the toner-cartridge door



RM2-5392-000CN 250-sheet paper input tray

- [Introduction](#)
- [Step 1: Remove Tray 2](#)
- [Step 2: Unpack the replacement assembly](#)
- [Step 3: Install Tray 2](#)

Introduction

This document provides the procedures to remove and replace Tray 2.

Before performing service

Turn the printer power off

- Disconnect the power cable.

 **WARNING!** To avoid damage to the printer, turn the printer off, wait 30 seconds, and then remove the power cable before attempting to service the printer.

Use the table below to identify the correct part number for your printer. To order the part, go to www.hp.com/buy/parts.

Tray 2 part number	
RM2-5392-000CN	Cassette (Tray 2) assembly

Required tools

- No special tools are required to remove this part.

After performing service

Turn the printer power on

- Connect the power cable.
- Use the power switch to turn the power on.

Post service test

Make sure that the printer initializes to a **Ready** state.

Print a configuration page (from Tray 2) to make sure that the printer is functioning correctly.

Step 1: Remove Tray 2

- ▲ Pull the tray straight out of the printer to remove it.

Figure 1-9 Remove the tray



Step 2: Unpack the replacement assembly

Unpack the replacement part from the packaging.

<http://www8.hp.com/us/en/hp-information/environment/product-recycling.html>

 **NOTE:** HP recommends responsible disposal of the defective part.

Figure 1-10 Recycle and unpack

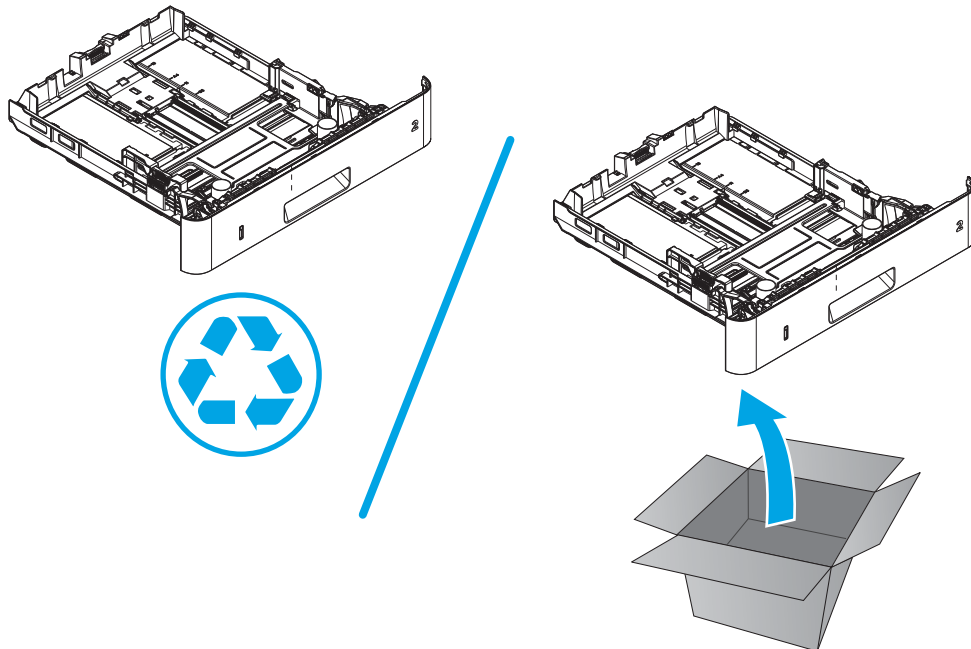

Step 3: Install Tray 2

- ▲ Slide the tray straight into the printer to install it.

Figure 1-11 Install the tray



RM2-5413-000CN optional Tray 3

- [Introduction](#)
- [Step 1: Remove optional Tray 3](#)
- [Step 2: Unpack the replacement assembly](#)
- [Step 3: Install optional Tray 3](#)

Introduction

This document provides the procedures to remove and replace the optional Tray 3.

Before performing service

Turn the printer power off

- Disconnect the power cable.

 **WARNING!** To avoid damage to the printer, turn the printer off, wait 30 seconds, and then remove the power cable before attempting to service the printer.

Use the table below to identify the correct part number for your printer. To order the part, go to www.hp.com/buy/parts.

Tray 3 part number	
RM2-5413-000CN	550-sheet paper feeder cassette (optional Tray 3)

Required tools

- No special tools are required to remove this part.

After performing service

Turn the printer power on

- Connect the power cable.
- Use the power switch to turn the power on.

Post service test

Make sure that the printer initializes to a **Ready** state.

Print a page from Tray 3 to make sure that the paper feeder is functioning correctly.

Step 1: Remove optional Tray 3

1. Pull the tray straight out of the printer until it stops.

Figure 1-12 Pull the tray out of the printer

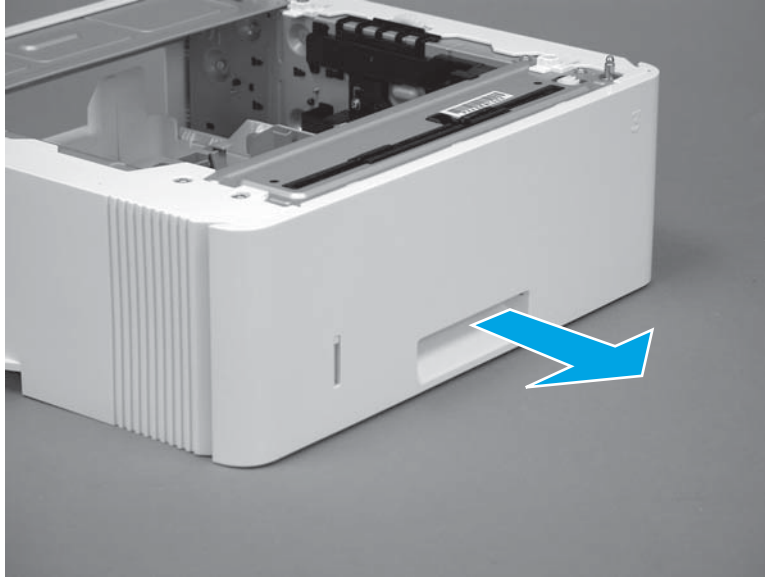

2. Slightly lift up on the front of the tray to release it, and then continue to pull the tray out of the accessory to remove it.

Figure 1-13 Release and remove the tray

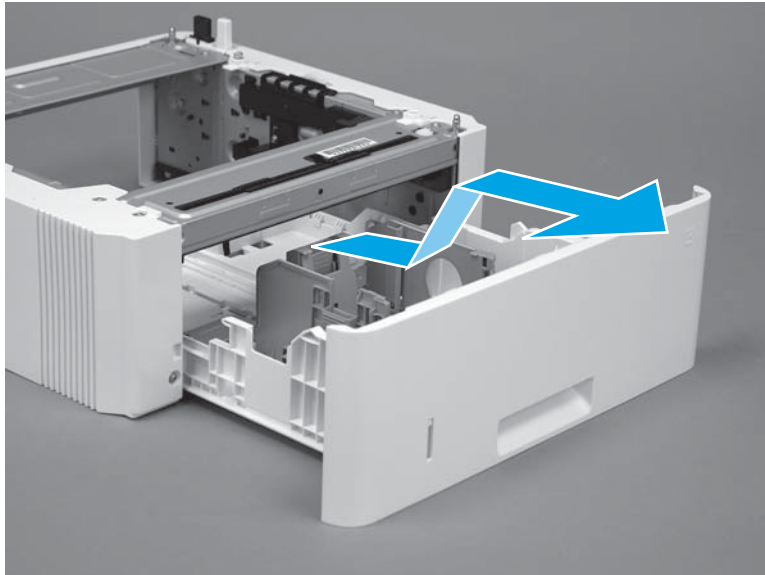

Step 2: Unpack the replacement assembly

Unpack the replacement part from the packaging.

<http://www8.hp.com/us/en/hp-information/environment/product-recycling.html>



NOTE: HP recommends responsible disposal of the defective part.

Figure 1-14 Recycle and unpack

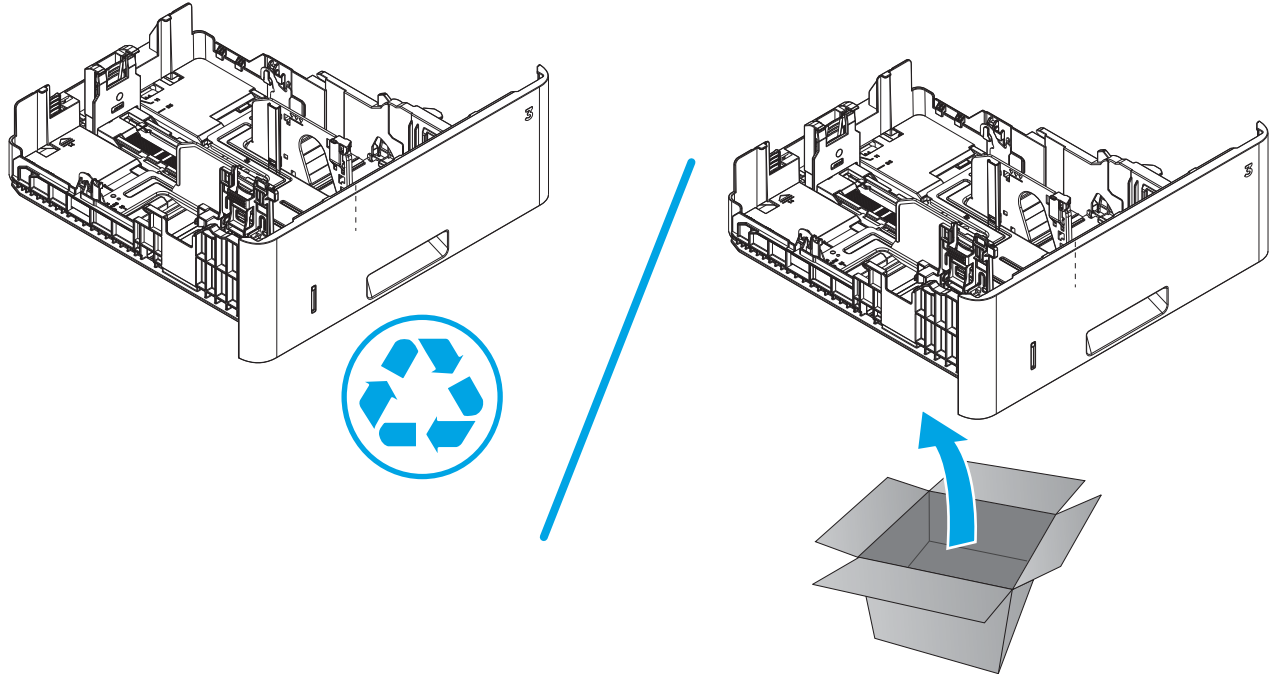

Step 3: Install optional Tray 3

1. With the tray at a slight angle, align the sides of the tray with the rails in the accessory, and then partially slide the tray into the accessory.

Figure 1-15 Install the tray

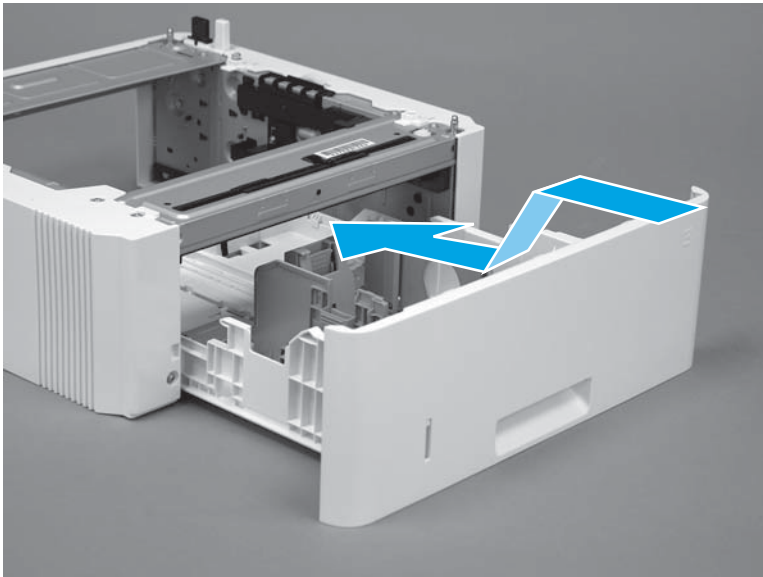

2. Push the tray straight into the accessory to close it.

Figure 1-16 Close the tray

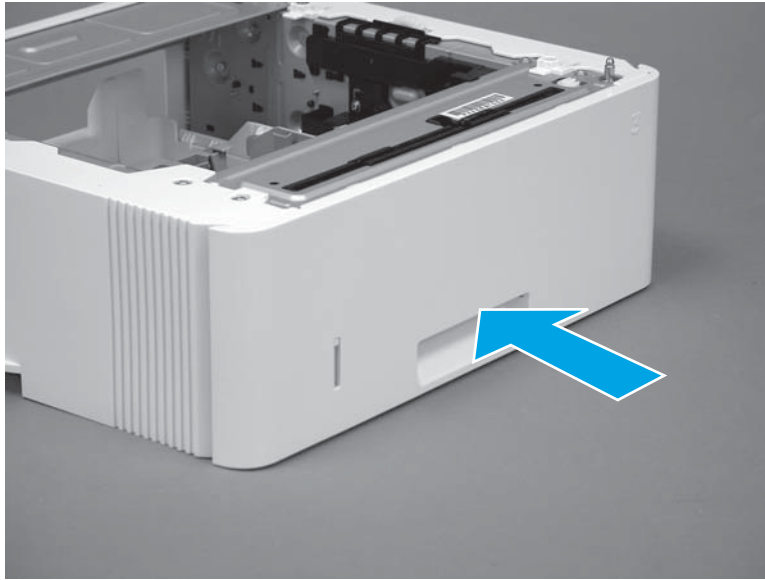

RM2-5452-000CN Tray 2 paper pickup roller assembly

- [Introduction](#)
- [Step 1: Remove Tray 2](#)
- [Step 2: Remove the pickup roller assembly \(Tray 2\)](#)
- [Step 3: Unpack the replacement assembly](#)
- [Step 4: Install the pickup roller assembly \(Tray 2\)](#)
- [Step 5: Install Tray 2](#)

Introduction

This document provides the procedures to remove and replace the paper pickup roller assembly (Tray 2).

Before performing service

Turn the printer power off

- Disconnect the power cable.

 **WARNING!** To avoid damage to the printer, turn the printer off, wait 30 seconds, and then remove the power cable before attempting to service the printer.

Use the table below to identify the correct part number for your printer. To order the part, go to www.hp.com/buy/parts.

Paper pickup roller assembly (Tray 2) part number	
RM2-5452-000CN	Paper pickup roller assembly (Tray 2)

Required tools

- No special tools are required to remove this part.

After performing service

Turn the printer power on

- Connect the power cable.
- Use the power switch to turn the power on.

Post service test

Make sure that the printer initializes to a **Ready** state.

Print a page from Tray 2 to make sure that the printer is functioning correctly.

Step 1: Remove Tray 2

- ▲ Pull the tray straight out of the printer to remove it.

Figure 1-17 Remove the tray



Step 2: Remove the pickup roller assembly (Tray 2)

CAUTION: When handling the roller holder, do not touch the gray spongy portion of the rollers. Skin oils on the rollers can cause paper handling problems.

NOTE: The M403/M402 printer is shown in this procedure. However, the procedure is valid for the M427/M426 printers.

1. Carefully rotate the printer backward.

CAUTION: To avoid damage to the rear cassette cover, keep it in the closed position.

Figure 1-18 Tilt the printer backward

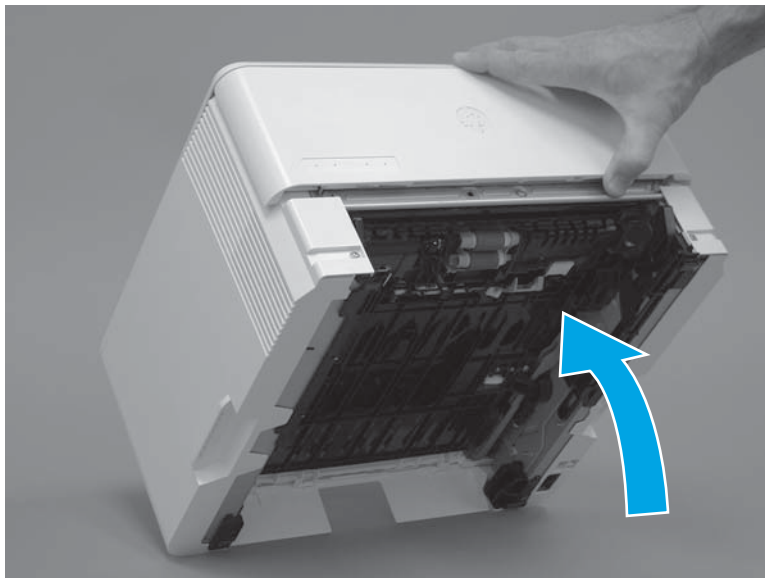

2. Continue rotate the printer backward until it rests on the rear cover, bottom-side face forward.

⚠ CAUTION: M427/M426: The integrated scanner assembly (ISA) is not captive, and can unexpectedly open when the printer is tilted back.

Figure 1-19 Place the printer bottom-side face forward

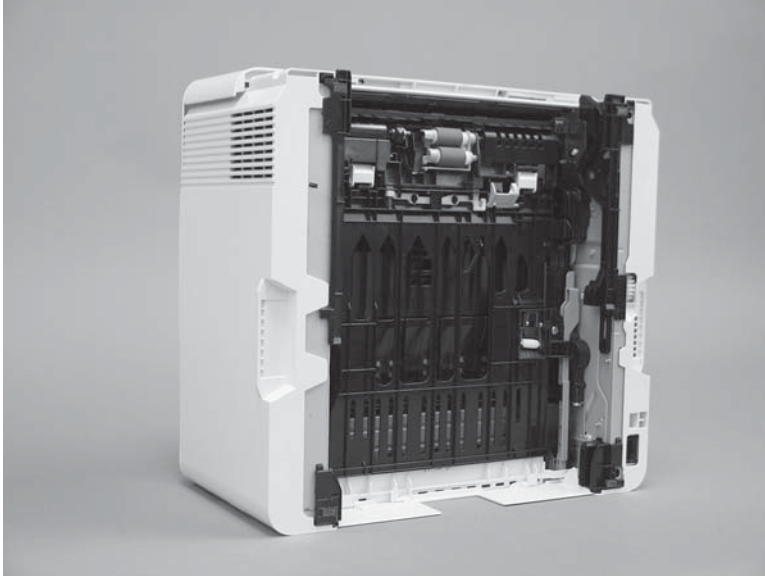

3. Release one tab (callout 1), and then slide the roller holder toward the left side of the printer to release it.

Figure 1-20 Release one tab

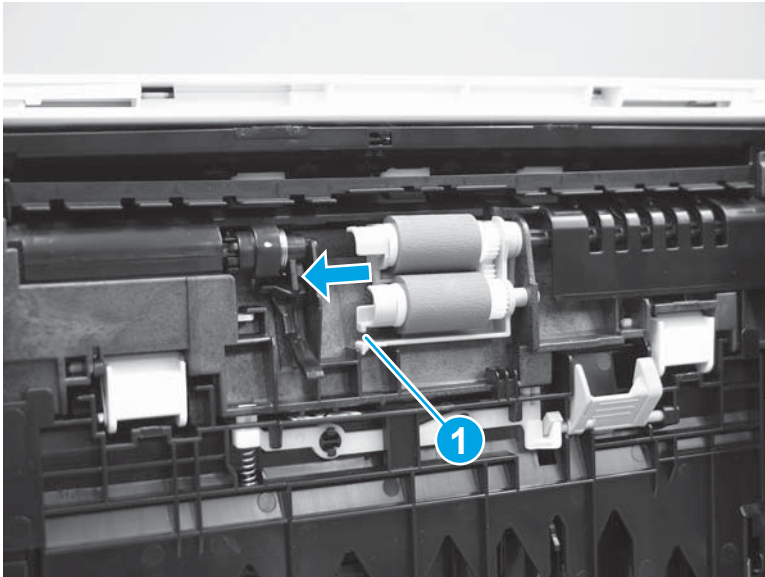

4. Remove the roller holder.

Figure 1-21 Remove the roller holder

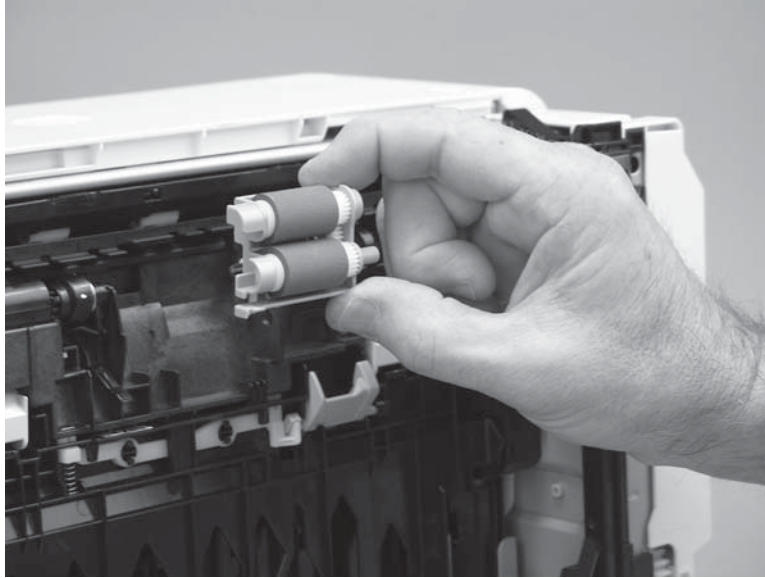

Step 3: Unpack the replacement assembly

Unpack the replacement part from the packaging.

<http://www8.hp.com/us/en/hp-information/environment/product-recycling.html>

CAUTION: When handling the roller holder, do not touch the gray spongy portion of the rollers. Skin oils on the rollers can cause paper handling problems.

NOTE: HP recommends responsible disposal of the defective part.

Figure 1-22 Recycle and unpack

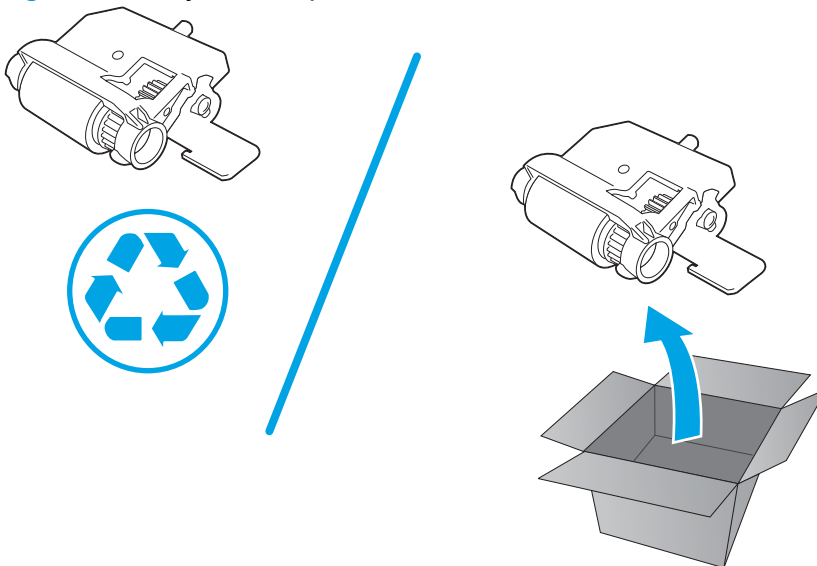

Step 4: Install the pickup roller assembly (Tray 2)

CAUTION: When handling the roller holder, do not touch the gray spongy portion of the rollers. Skin oils on the rollers can cause paper handling problems.

NOTE: The M403/M402 printer is shown in this procedure. However, the procedure is valid for the M427/M426 printers.

1. Position the roller holder assembly in the printer as shown, and then slide it toward the right side of the printer.

Figure 1-23 Install the roller holder

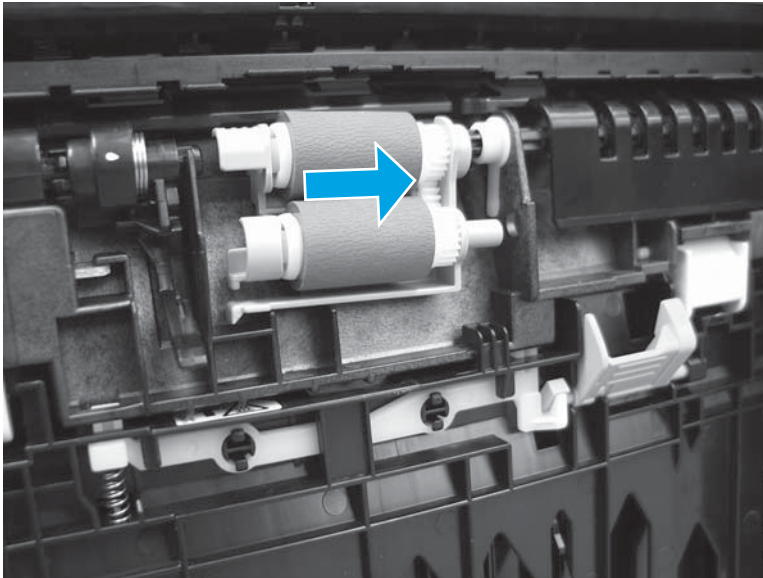

2. Make sure that the tab snaps into place.

Figure 1-24 Check the tab

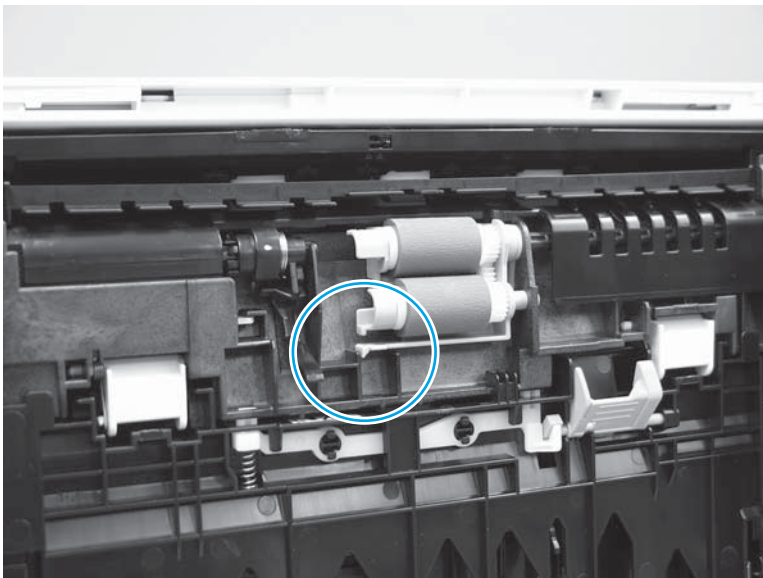

- Carefully rotate the printer forward.

Figure 1-25 Rotate the printer forward

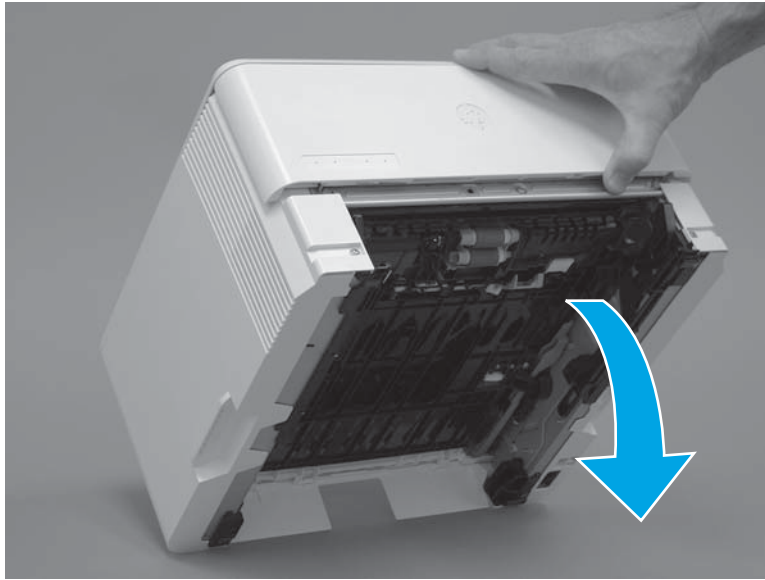

- Continue rotate the printer forward until it rests in the operational position.

Figure 1-26 Place the printer in the operational position



Step 5: Install Tray 2

- ▲ Slide the tray straight into the printer to install it.

Figure 1-27 Install the tray



RM2-5741-000CN optional Tray 3 paper pickup roller assembly

- [Introduction](#)
- [Step 1: Remove optional Tray 3](#)
- [Step 2: Remove the paper pickup roller assembly \(optional Tray 3\)](#)
- [Step 3: Unpack the replacement assembly](#)
- [Step 4: Install the paper pickup roller assembly \(optional Tray 3\)](#)
- [Step 5: Install optional Tray 3](#)

Introduction

This document provides the procedures to remove and replace the paper pickup roller assembly (Tray 3).

Before performing service

Turn the printer power off

- Disconnect the power cable.

 **WARNING!** To avoid damage to the printer, turn the printer off, wait 30 seconds, and then remove the power cable before attempting to service the printer.

Use the table below to identify the correct part number for your printer. To order the part, go to www.hp.com/buy/parts.

Paper pickup roller assembly (Tray 3) part number	
RM2-5741-000N	Paper pickup roller assembly (Tray 3)

Required tools

- No special tools are required to remove this part.

After performing service

Turn the printer power on

- Connect the power cable.
- Use the power switch to turn the power on.

Post service test

Make sure that the printer initializes to a **Ready** state.

Print a page from the accessory to make sure that the printer is functioning correctly.

Step 1: Remove optional Tray 3

1. Pull the tray straight out of the printer until it stops.

Figure 1-28 Pull the tray out of the printer

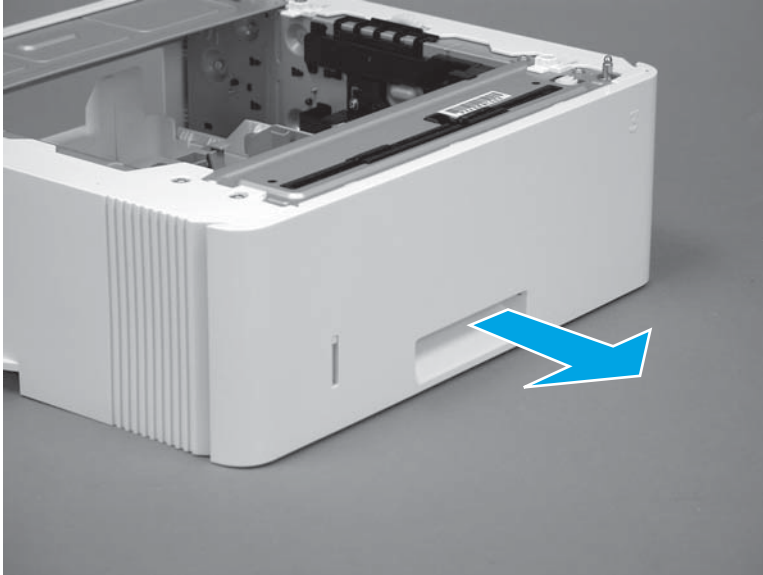

2. Slightly lift up on the front of the tray to release it, and then continue to pull the tray out of the accessory to remove it.

Figure 1-29 Release and remove the tray

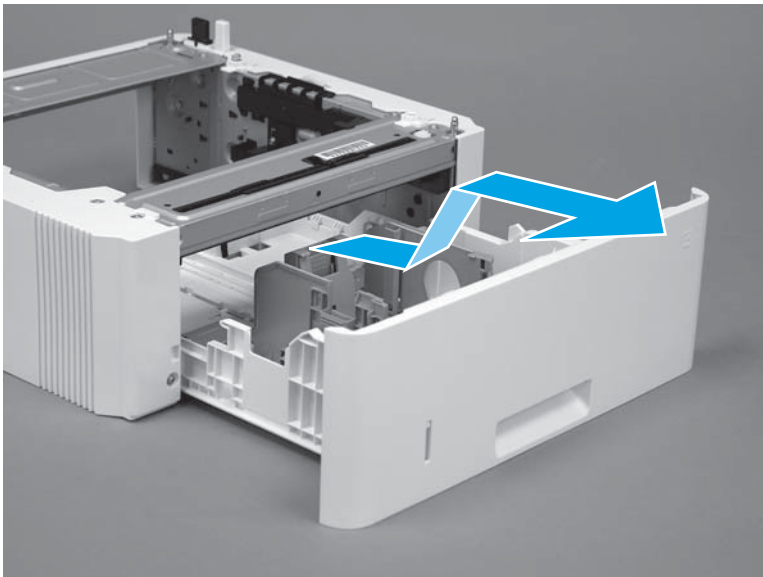

Step 2: Remove the paper pickup roller assembly (optional Tray 3)

CAUTION: When handling the roller holder, do not touch the gray spongy portion of the rollers. Skin oils on the rollers can cause paper handling problems.

1. Carefully turn the accessory over to expose the roller assembly.

Figure 1-30 Turn the accessory over

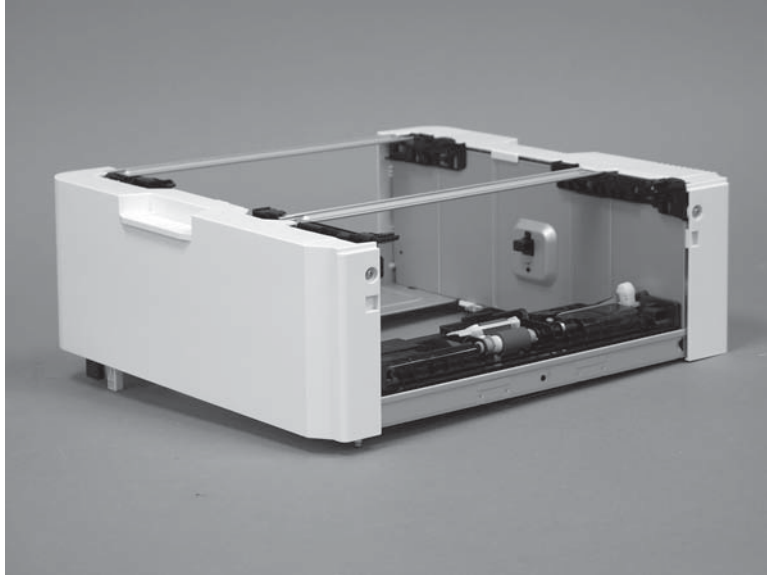

2. Slide the roller holder to the right to compress the spring-loaded shaft and release the assembly.

Figure 1-31 Release the assembly

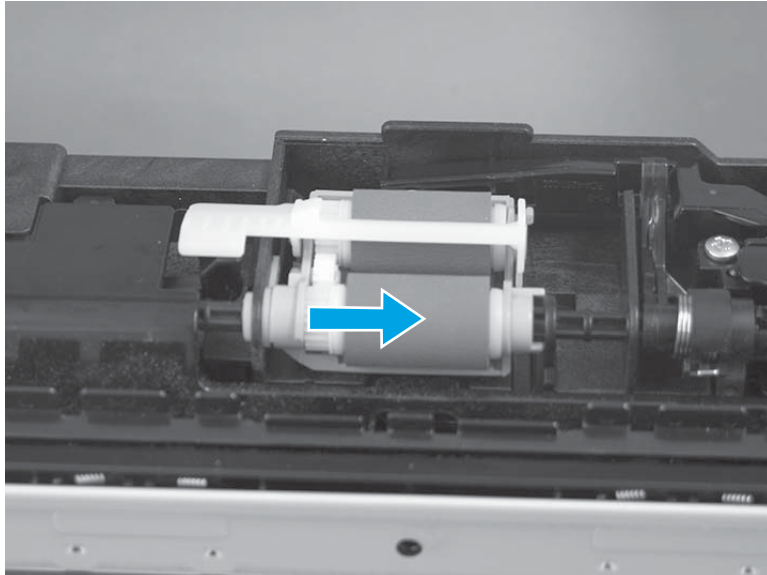

3. Rotate the end of the assembly up and away from the accessory.

Figure 1-32 Rotate the assembly up

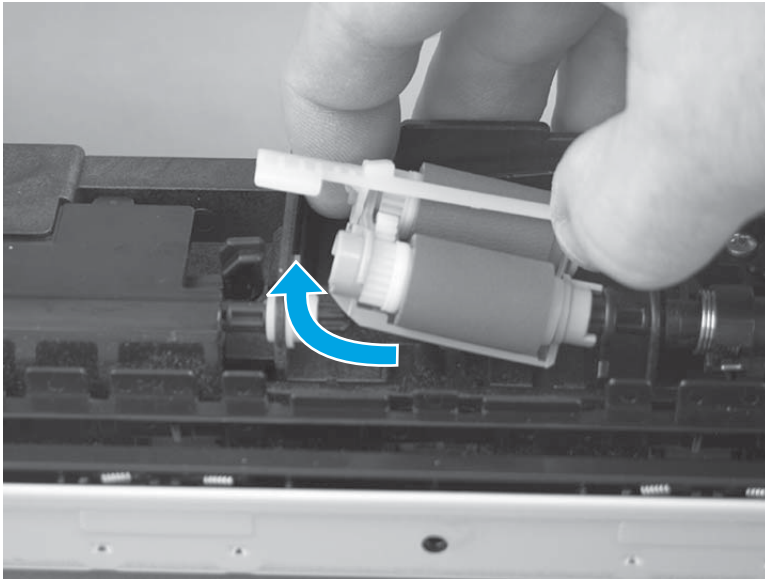

4. Remove the roller assembly.

Figure 1-33 Remove the assembly

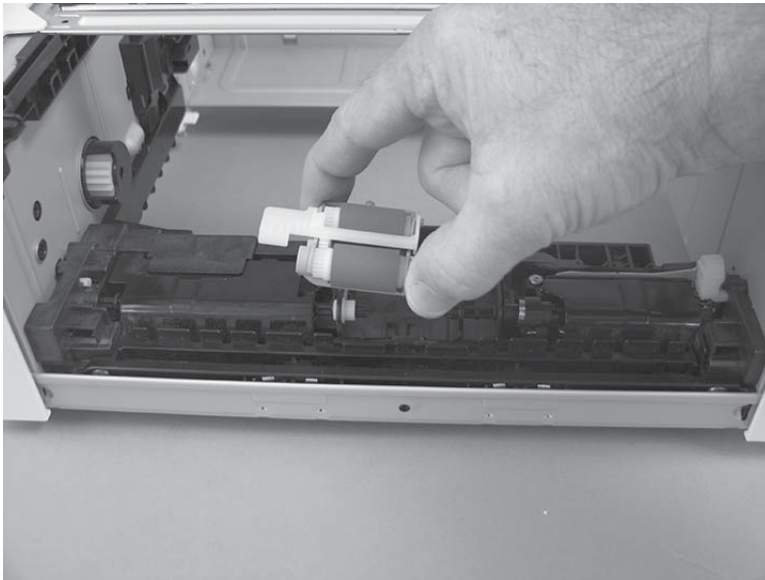

Step 3: Unpack the replacement assembly

Unpack the replacement part from the packaging.

<http://www8.hp.com/us/en/hp-information/environment/product-recycling.html>

CAUTION: When handling the roller holder, do not touch the gray spongy portion of the rollers. Skin oils on the rollers can cause paper handling problems.

NOTE: HP recommends responsible disposal of the defective part.

Figure 1-34 Recycle and unpack

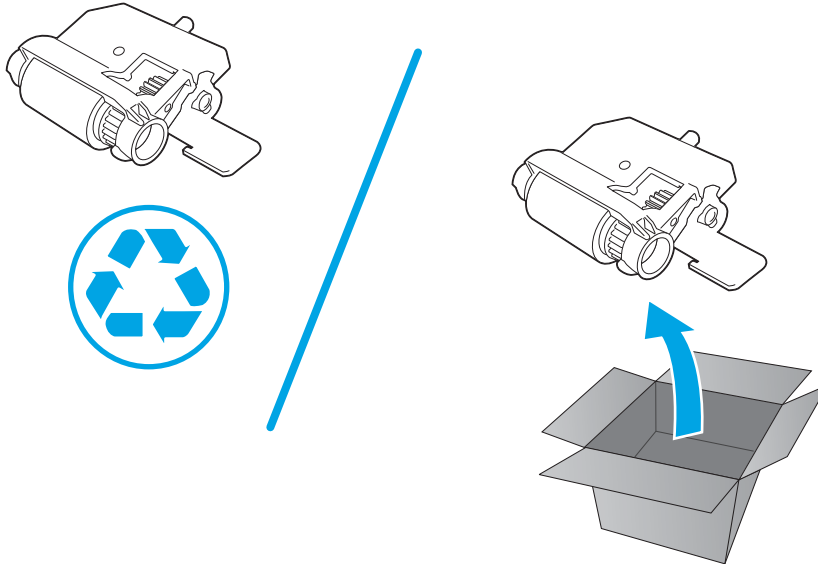

Step 4: Install the paper pickup roller assembly (optional Tray 3)

CAUTION: When handling the roller holder, do not touch the gray spongy portion of the rollers. Skin oils on the rollers can cause paper handling problems.

1. Install the right end of the assembly on the spring-loaded shaft (callout 1), and then slide it to the right to compress the shaft (callout 2).

IMPORTANT: Make sure that the pin on the back of the holder (callout 3) is inserted in the slot (callout 4) in the lever arm. If the pin is not correctly installed, the accessory will not pick paper.

Figure 1-35 Install the roller assembly

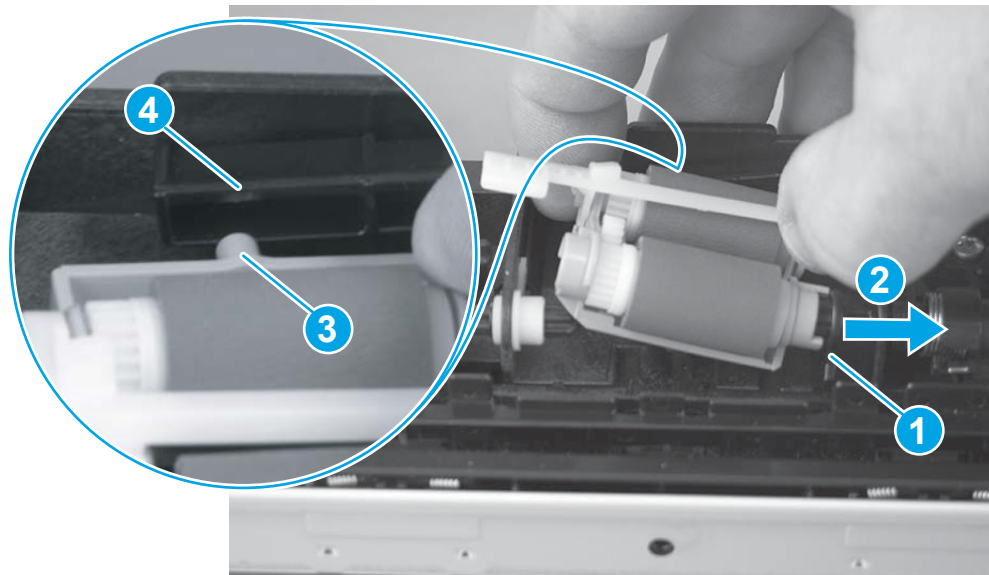

2. Rotate the left end of the assembly down and into place (callout 1), and then slide the assembly to the left (callout 2) to engage the drive end of the assembly with the drive shaft (callout 3).

Figure 1-36 Release the assembly

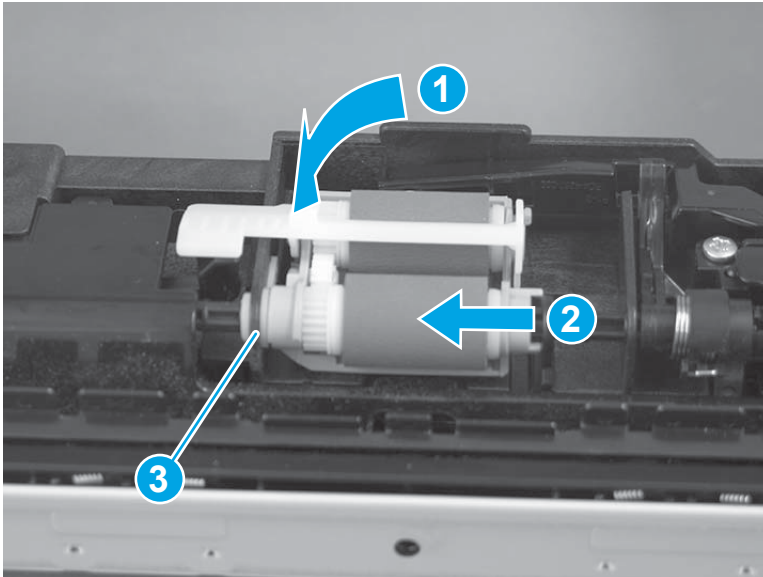

3. Push down and then release the tray-roller actuator (callout 1) and observe the roller assembly. It should move up and down (callout 2) in response to the actuator.

 **NOTE:** If it does not, remove the roller assembly and reinstall it making sure that the pin on the back of the assembly is in the lever arm. See [Figure 1-35 Install the roller assembly on page 31](#).

Figure 1-37 Check the installation

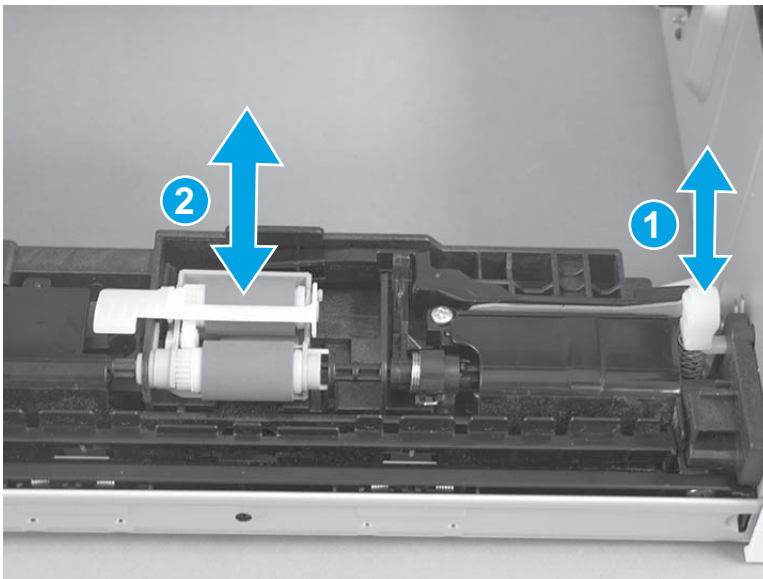

Step 5: Install optional Tray 3

1. With the tray at a slight angle, align the sides of the tray with the rails in the accessory, and then partially slide the tray into the accessory.

Figure 1-38 Install the tray

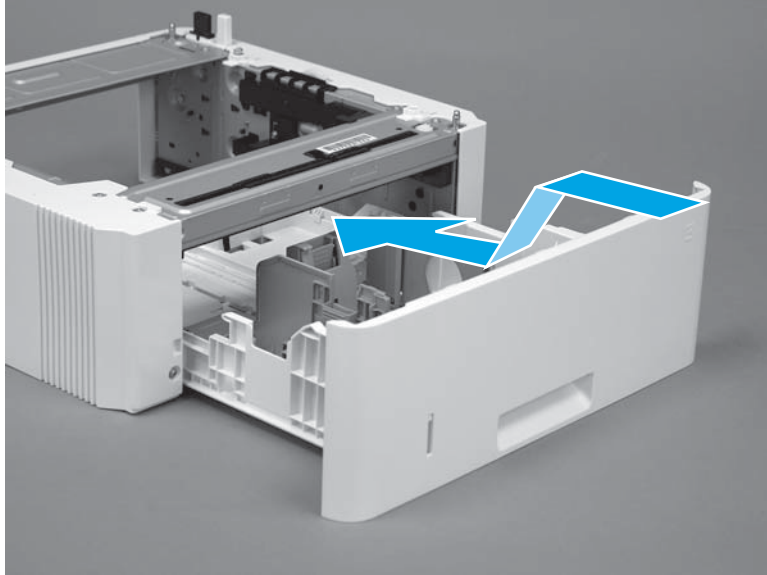

2. Push the tray straight into the accessory to close it.

Figure 1-39 Close the tray

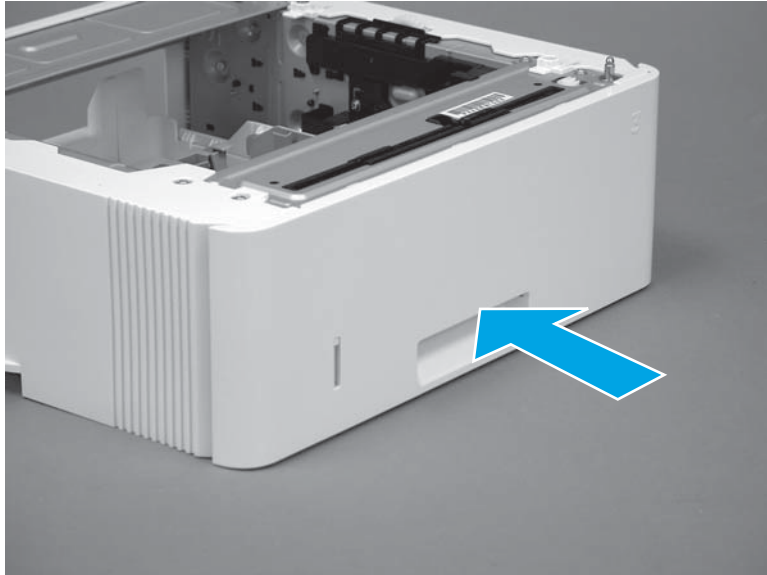

RM2-5397-000CN Tray 2 separation roller assembly

- [Introduction](#)
- [Step 1: Remove Tray 2](#)
- [Step 2: Remove the separation pad roller assembly \(Tray 2\)](#)
- [Step 3: Unpack the replacement assembly](#)
- [Step 4: Install the separation pad roller assembly \(Tray 2\)](#)
- [Step 5: Install Tray 2](#)

Introduction

This document provides the procedures to remove and replace the separation roller assembly (Tray 2).

Before performing service

Turn the printer power off

- Disconnect the power cable.

 **WARNING!** To avoid damage to the printer, turn the printer off, wait 30 seconds, and then remove the power cable before attempting to service the printer.

Use the table below to identify the correct part number for your printer. To order the part, go to www.hp.com/buy/parts.

Separation roller assembly (Tray 2) part number	
---	--

RM2-5397-000CN

Separation roller assembly (Tray 2)

Required tools

- No special tools are required to install this kit.

After performing service

Turn the printer power on

- Connect the power cable.
- Use the power switch to turn the power on.

Post service test

Make sure that the printer initializes to a **Ready** state.

Print a configuration page to make sure that the printer is functioning correctly.

Step 1: Remove Tray 2

- ▲ Pull the tray straight out of the printer to remove it.

Figure 1-40 Remove the tray



Step 2: Remove the separation pad roller assembly (Tray 2)

1. Press the locking lever (callout 1), and then pull the separation roller assembly straight up to release it.

Figure 1-41 Release the assembly

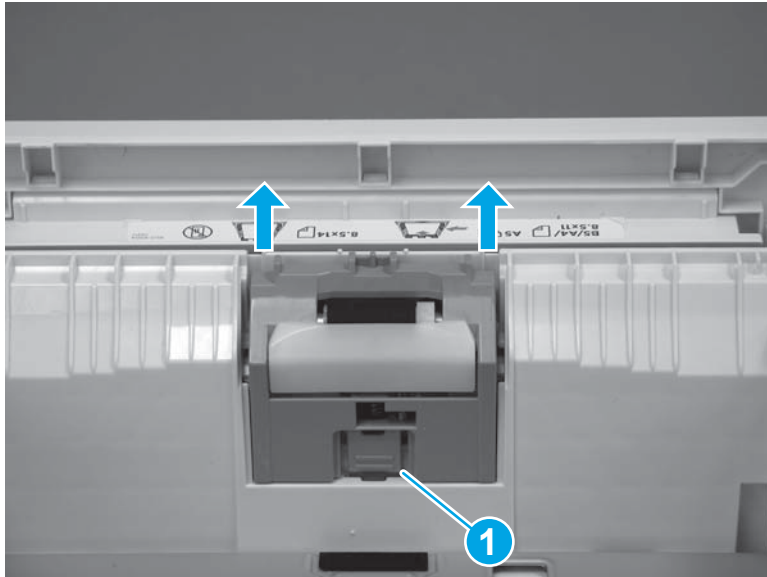

2. Remove the assembly.

Figure 1-42 Remove the assembly

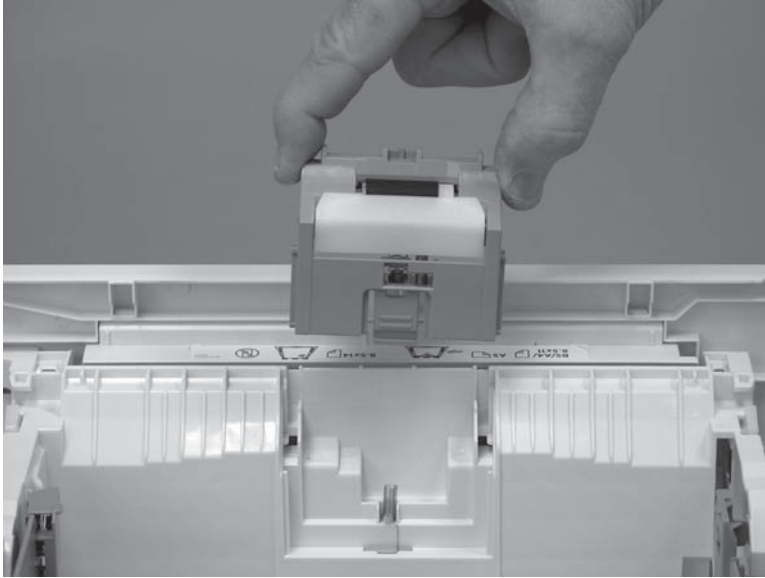

Step 3: Unpack the replacement assembly

Unpack the replacement part from the packaging.

<http://www8.hp.com/us/en/hp-information/environment/product-recycling.html>

 **NOTE:** HP recommends responsible disposal of the defective part.

Figure 1-43 Recycle and unpack

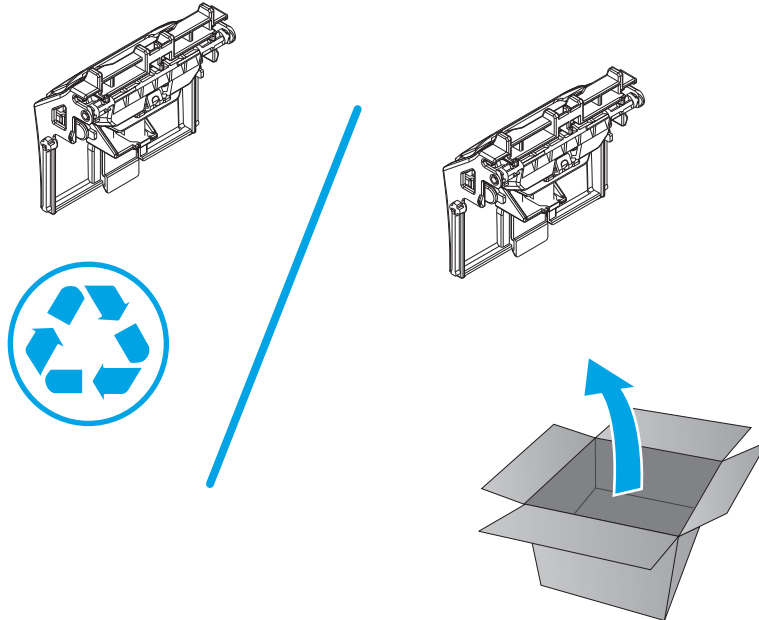

Step 4: Install the separation pad roller assembly (Tray 2)

1. Install the assembly in the slots in the cassette.

Figure 1-44 Install the assembly

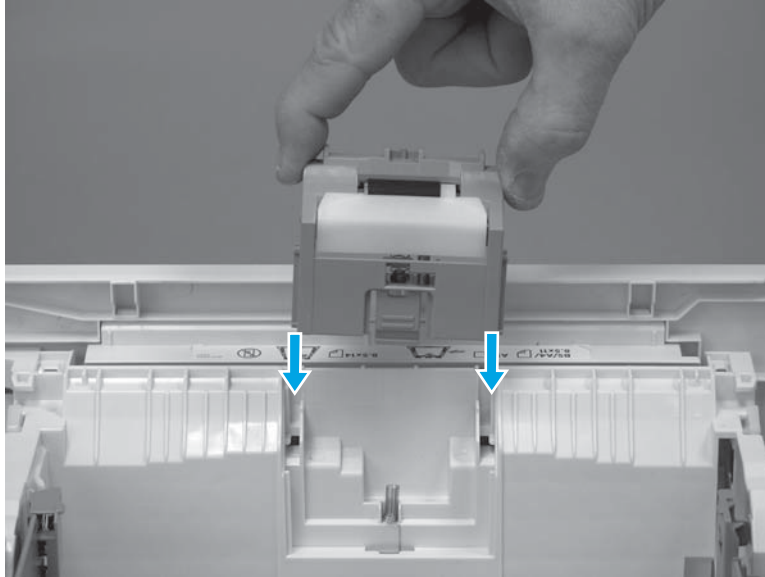

2. Push the separation roller assembly straight down until it snaps into place.

Figure 1-45 Release the assembly

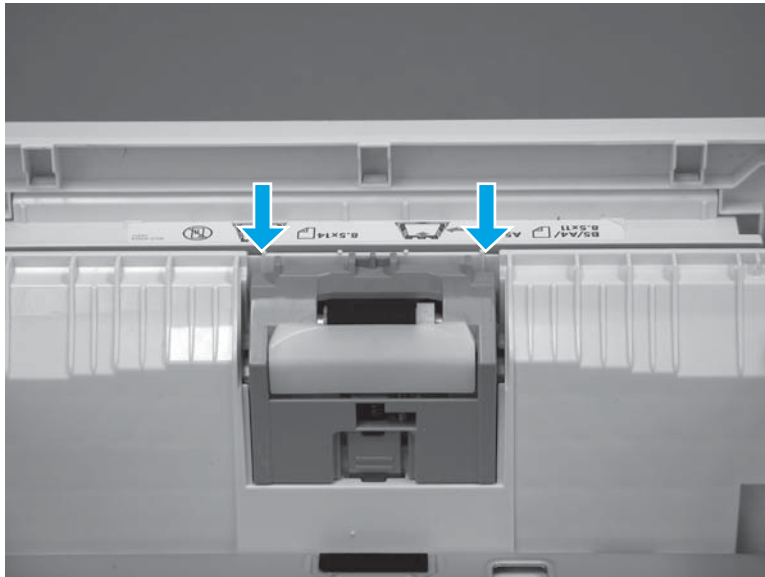

Step 5: Install Tray 2

- ▲ Slide the tray straight into the printer to install it.

Figure 1-46 Install the tray



RM2-5745-000CN optional Tray 3 separation roller assembly

- [Introduction](#)
- [Step 1: Remove Tray 3](#)
- [Step 2: Remove the separation roller assembly \(optional Tray 3\)](#)
- [Step 3: Unpack the replacement assembly](#)
- [Step 4: Install the separation roller assembly \(optional Tray 3\)](#)
- [Step 5: Install Tray 3](#)

Introduction

This document provides the procedures to remove and replace the separation roller assembly (500-sheet feeder).

Before performing service

Turn the printer power off

- Disconnect the power cable.

 **WARNING!** To avoid damage to the printer, turn the printer off, wait 30 seconds, and then remove the power cable before attempting to service the printer.

Use the table below to identify the correct part number for your printer. To order the part, go to www.hp.com/buy/parts.

Separation roller assembly (550-sheet feeder) part number	
RM2-5745-000CN	Separation roller assembly (550-sheet feeder)

Required tools

- No special tools are required to install this kit.

After performing service

Turn the printer power on

- Connect the power cable.
- Use the power switch to turn the power on.

Post service test

Make sure that the printer initializes to a **Ready** state.

Print a page from the accessory to make sure that the accessory is functioning correctly.

Step 1: Remove Tray 3

1. Pull the tray straight out of the printer until it stops.

Figure 1-47 Pull the tray out of the printer

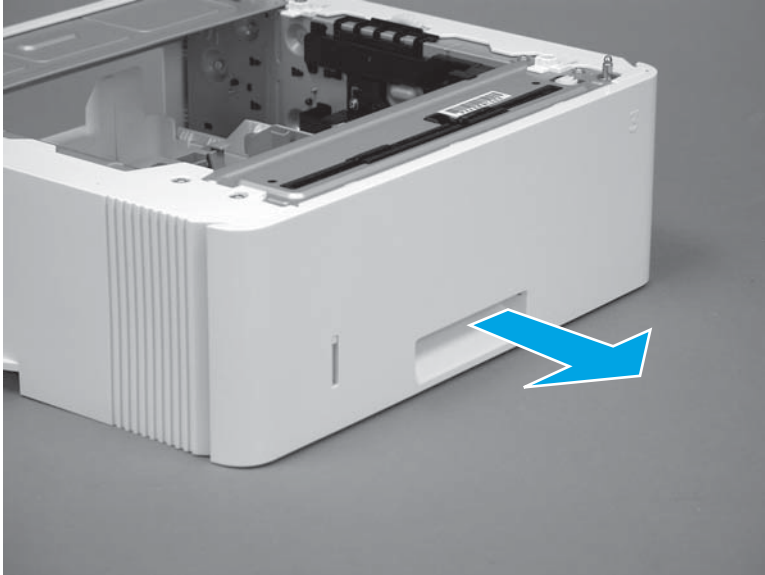

2. Slightly lift up on the front of the tray to release it, and then continue to pull the tray out of the accessory to remove it.

Figure 1-48 Release and remove the tray

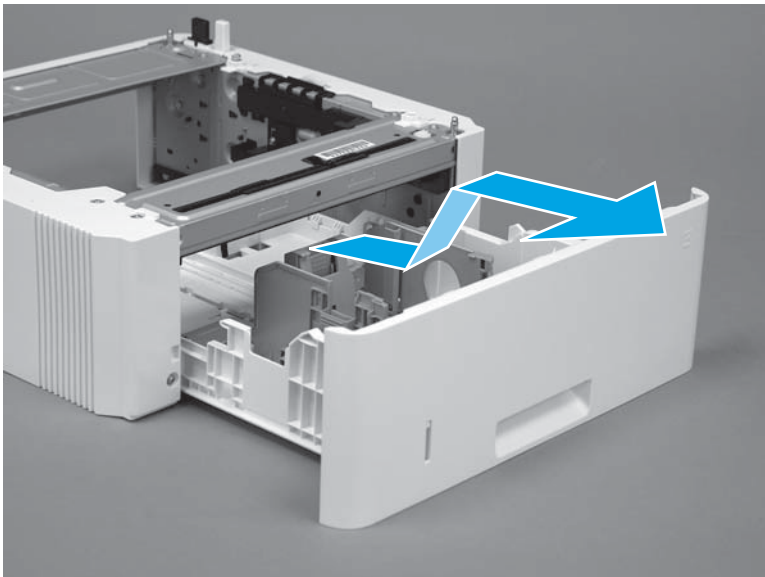

Step 2: Remove the separation roller assembly (optional Tray 3)

1. Press the locking lever (callout 1), and then pull the separation roller assembly straight up to release it.

Figure 1-49 Release the assembly

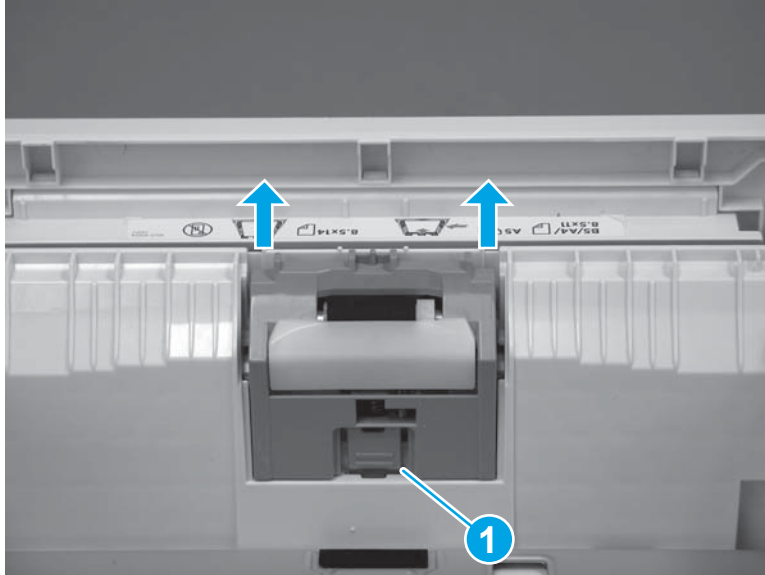

2. Remove the assembly.

Figure 1-50 Remove the assembly

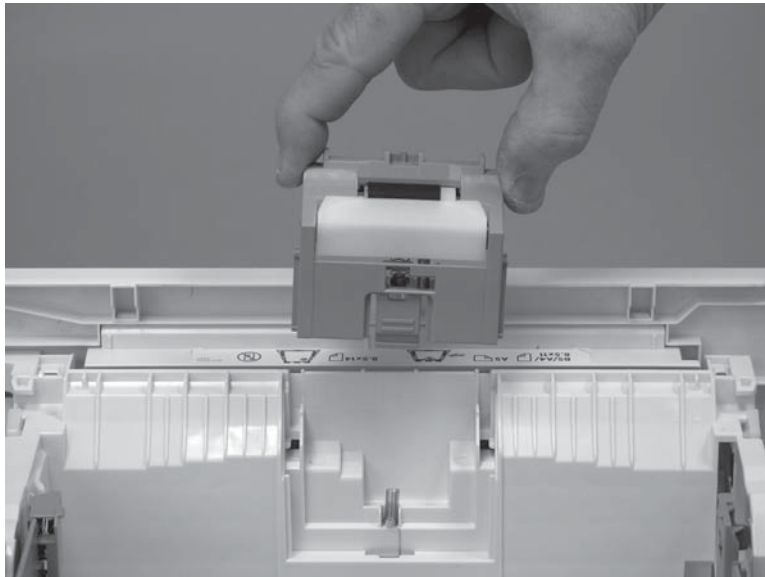

Step 3: Unpack the replacement assembly

Unpack the replacement part from the packaging.

<http://www8.hp.com/us/en/hp-information/environment/product-recycling.html>



NOTE: HP recommends responsible disposal of the defective part.

Figure 1-51 Recycle and unpack

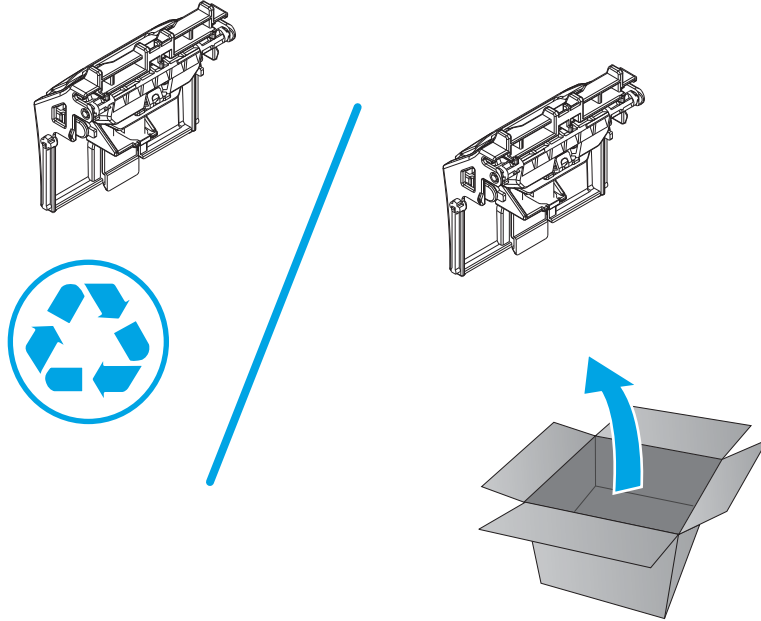

Step 4: Install the separation roller assembly (optional Tray 3)

1. Install the assembly in the slots in the cassette.

Figure 1-52 Install the assembly

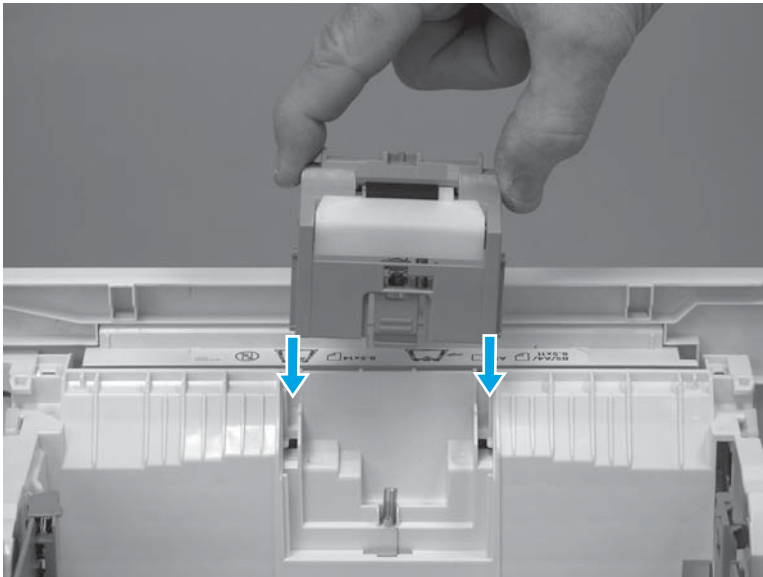

2. Push the separation roller assembly straight down until it snaps into place.

Figure 1-53 Release the assembly

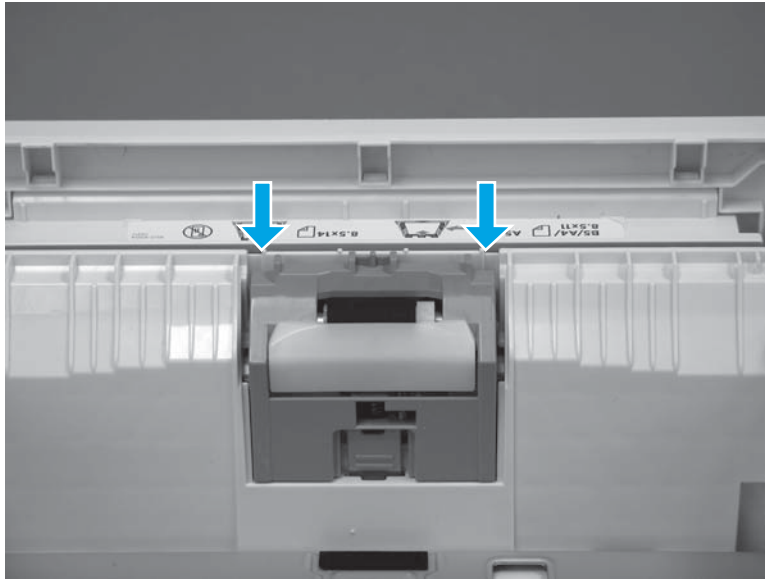

Step 5: Install Tray 3

1. With the tray at a slight angle, align the sides of the tray with the rails in the accessory, and then partially slide the tray into the accessory.

Figure 1-54 Install the tray

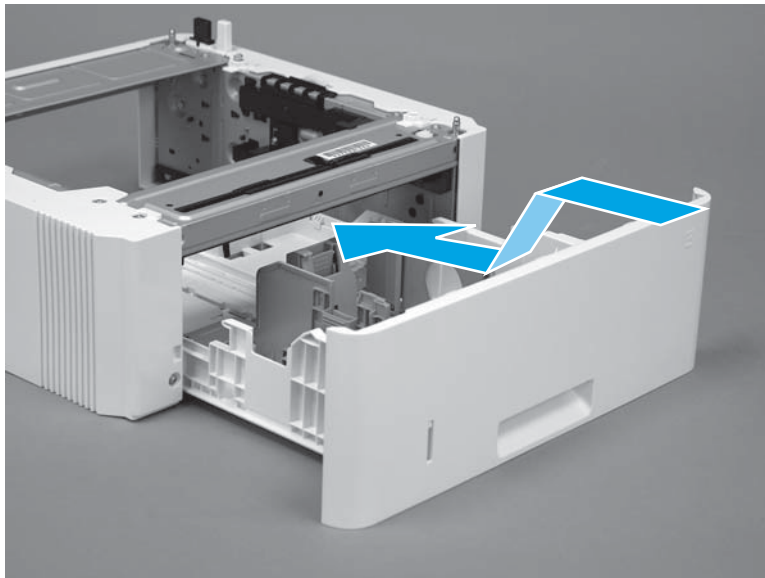

2. Push the tray straight into the accessory to close it.

Figure 1-55 Close the tray

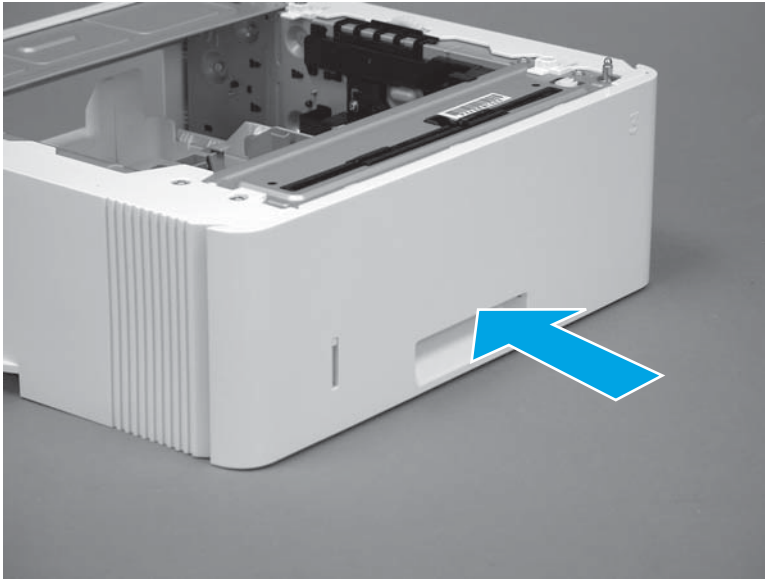

Removal and replacement: External panels, covers, and doors

- [Removal and replacement: Damper sheets](#)
- [Removal and replacement: Rear USB cover](#)
- [Removal and replacement: Support shaft](#)
- [Removal and replacement: Cartridge door assembly](#)
- [Removal and replacement: Pressure-release link](#)
- [Removal and replacement: Left cover](#)
- [Removal and replacement: Right cover](#)
- [Removal and replacement: Rear door assembly](#)
- [Removal and replacement: Cassette rear cover](#)
- [Removal and replacement: Top cover \(M427/M426\)](#)
- [Removal and replacement: Cable guide \(M427/M426\)](#)
- [Removal and replacement: Top cover \(M403/M402\)](#)
- [Removal and replacement: 2-line LCD operator and indication covers \(M403/M402\)](#)
- [Removal and replacement: Paper delivery tray \(output bin\)](#)
- [Removal and replacement: Integrated scanner assembly \(M427/M426\)](#)
- [Removal and replacement: ISA lift assembly and slider pin \(M427/M426\)](#)

Removal and replacement: Damper sheets

- [Introduction](#)
- [Step 1: Remove the damper sheets](#)
- [Step 2: Unpack the replacement assembly](#)
- [Step 3: Install the damper sheets](#)

Introduction

This document provides the procedures to remove and replace the damper sheets.

Before performing service

Turn the printer power off

- Disconnect the power cable.

 **WARNING!** To avoid damage to the printer, turn the printer off, wait 30 seconds, and then remove the power cord before attempting to service the printer.

Use the table below to identify the correct part number for your printer. To order the part, go to www.hp.com/buy/parts.

Damper sheets part number	
RC2-6075-000CN	Sheets, damper (2)

Required tools

- No special tools are needed to remove or install this assembly.

After performing service

Turn the printer power on

- Connect the power cable.
- Use the power switch to turn the power on.

Post service test

No post service test are available for this assembly.

Step 1: Remove the damper sheets

- ▲ Remove the damper sheets from the rear cover.

 **Reinstallation tip:** Make sure that all of the residual adhesive is removed from the rear cover damper sheet area. Residual adhesive can cause the replacement sheets to not adhere properly to the door.

Figure 1-56 Remove the damper sheets



Step 2: Unpack the replacement assembly

Unpack the replacement part from the packaging.

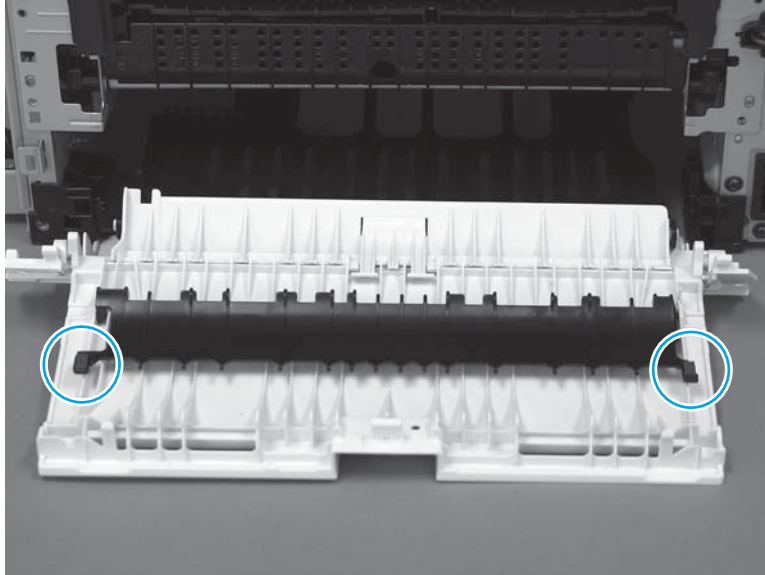
<http://www8.hp.com/us/en/hp-information/environment/product-recycling.html>

 **NOTE:** HP recommends responsible disposal of the defective part.

Figure 1-57 Recycle and unpack

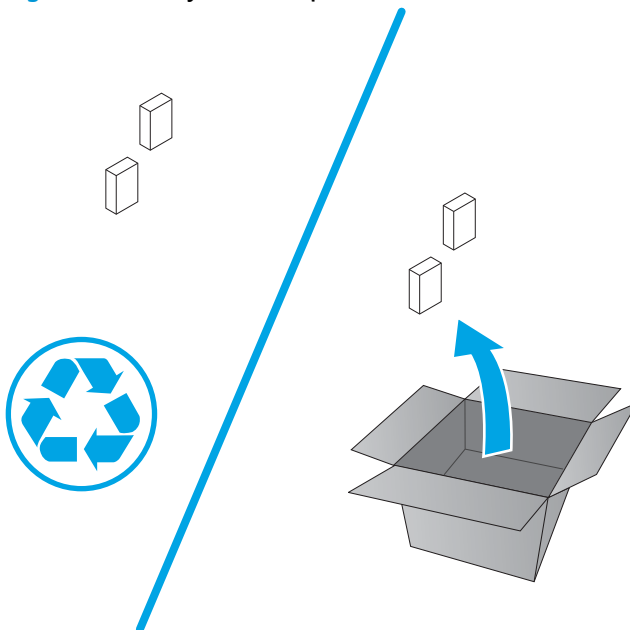

Step 3: Install the damper sheets

- ▲ Remove the protective backing to expose the adhesive side of the damper sheets, and then install them on the rear cover.

Figure 1-58 Install the damper sheets

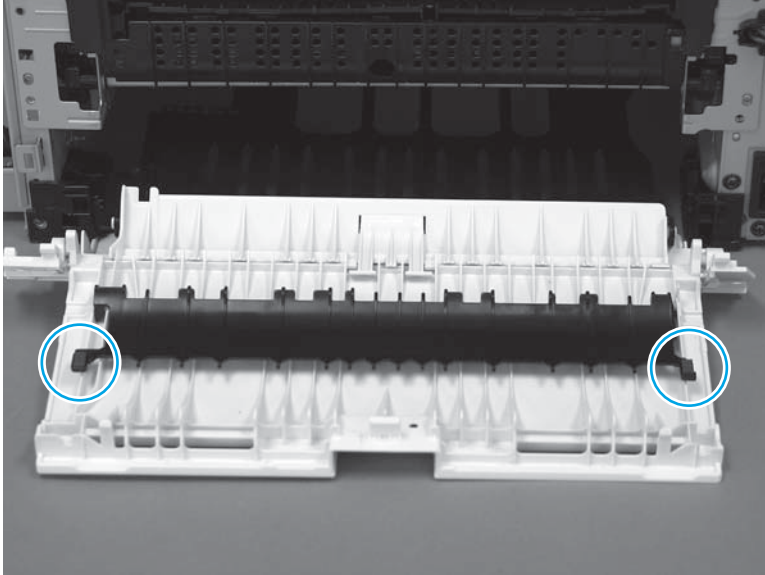

Removal and replacement: Rear USB cover

- [Introduction](#)
- [Step 1: Remove the rear USB cover](#)
- [Step 2: Unpack the replacement assembly](#)
- [Step 3: Install the rear USB cover](#)

Introduction

This document provides the procedures to remove and replace the rear USB cover.

Before performing service

Turn the printer power off

- Disconnect the power cable.

 **WARNING!** To avoid damage to the printer, turn the printer off, wait 30 seconds, and then remove the power cable before attempting to service the printer.

Use the table below to identify the correct part number for your printer. To order the part, go to www.hp.com/buy/parts.

Rear USB cover part number	
RC4-3298-000CN	Rear USB cover, small (M402/M403)
RC4-3299-000CN	Rear USB cover, small (M426/M427)

Required tools

- No special tools are needed to remove or install this assembly.

After performing service

Turn the printer power on

- Connect the power cable.
- Use the power switch to turn the power on.

Post service test

No post service test are available for this assembly.

Step 1: Remove the rear USB cover

1. Use a finger to release two tabs (callout 1), and then pull the cover straight off of the printer.

Figure 1-59 Pull the cover straight off

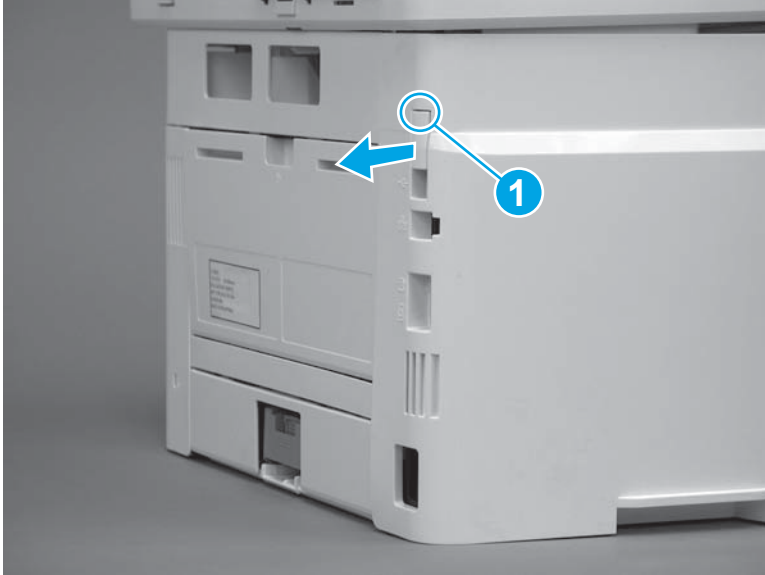

2. Remove the cover.



NOTE: For network models, also remove the network port cover (not shown; RC4-2907-000CN).

Figure 1-60 Remove the cover



Step 2: Unpack the replacement assembly

Unpack the replacement part from the packaging.

<http://www8.hp.com/us/en/hp-information/environment/product-recycling.html>



NOTE: HP recommends responsible disposal of the defective part.

Figure 1-61 Recycle and unpack

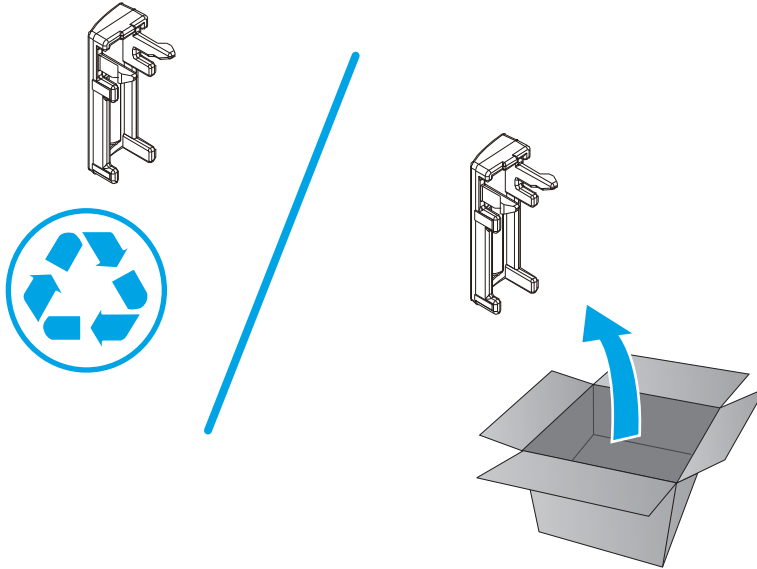

Step 3: Install the rear USB cover

1. Align the tabs on the cover with the slots in the left cover.

Figure 1-62 Align the tabs on the cover



2. Push the cover straight on to the printer to install it.

 **NOTE:** For network models, also install the network port cover (not shown; RC4-2907-000CN).

Figure 1-63 Install the cover



Removal and replacement: Support shaft

- [Introduction](#)
- [Step 1: Remove the support shaft](#)
- [Step 2: Unpack the replacement assembly](#)
- [Step 3: Install the support shaft](#)

Introduction

This document provides the procedures to remove and replace the toner-cartridge door support shaft.

Before performing service

Turn the printer power off

- Disconnect the power cable.

 **WARNING!** To avoid damage to the printer, turn the printer off, wait 30 seconds, and then remove the power cord before attempting to service the printer.

Use the table below to identify the correct part number for your printer. To order the part, go to www.hp.com/buy/parts.

Support shaft part number	
RC4-3002-000CN	Shaft, support

Required tools

- Optional: Small flat-blade screwdriver.

After performing service

Turn the printer power on

- Connect the power cable.
- Use the power switch to turn the power on.

Post service test

Make sure that toner toner-cartridge door correctly opens and closes.

Step 1: Remove the support shaft

1. Release the support shaft (callout 1), and then slide it toward the center of the door (callout 2).

 **TIP:** It might be easier to release the support shaft by using a small flat-blade screwdriver.

Figure 1-64 Release the support shaft

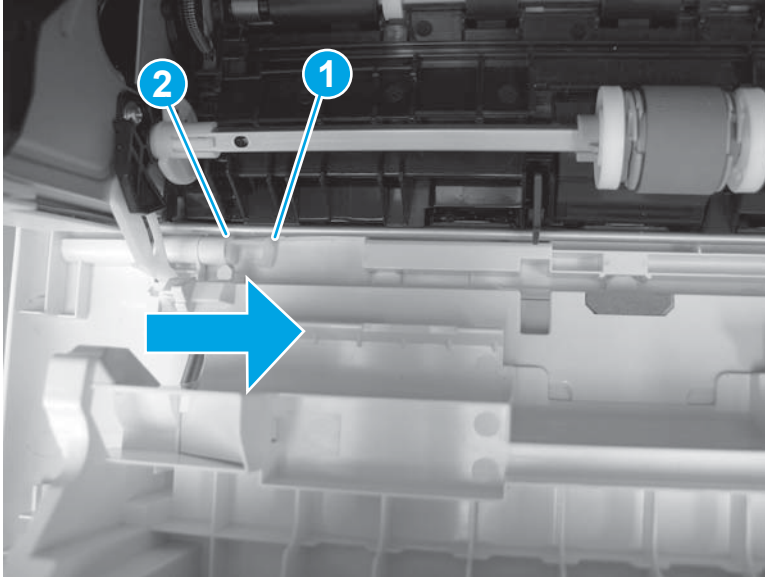

2. Remove the support shaft.

Figure 1-65 Remove the support shaft

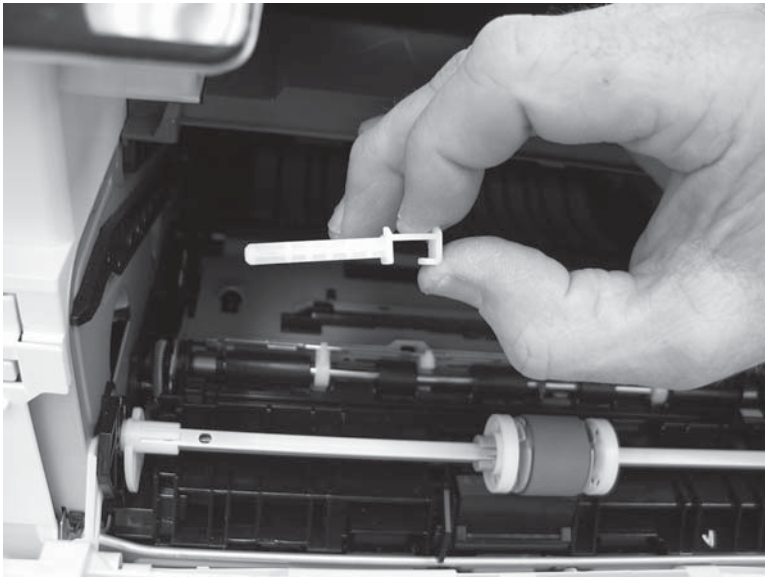

Step 2: Unpack the replacement assembly

Unpack the replacement part from the packaging.

<http://www8.hp.com/us/en/hp-information/environment/product-recycling.html>



NOTE: HP recommends responsible disposal of the defective part.

Figure 1-66 Recycle and unpack

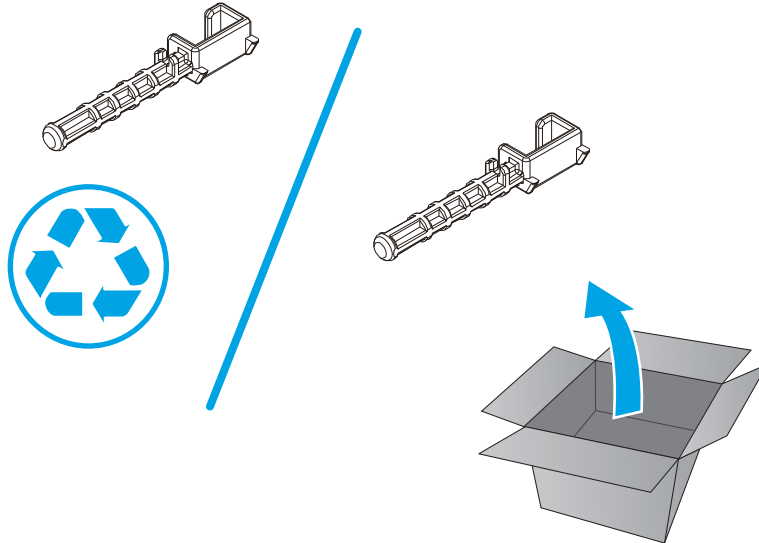

Step 3: Install the support shaft

1. Position the support shaft on the door, and then align the left-side hinge on the door with the hole in the chassis (callout 1).

Figure 1-67 Align the hinge

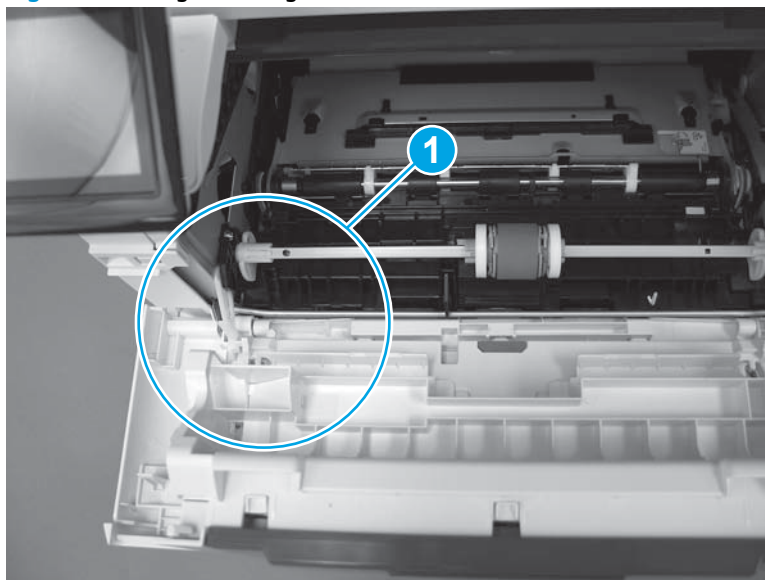

2. Push the shaft towards the left side of the printer to install it (callout 1).

 **Reinstallation tip:** Make sure that the support shaft is fully installed and correctly orientated (callout 2) so that it will not interfere with the door opening and closing.

Figure 1-68 Install the support shaft



Removal and replacement: Cartridge door assembly

- [Introduction](#)
- [Step 1: Remove the cartridge door assembly](#)
- [Step 2: Unpack the replacement assembly](#)
- [Step 3: Install the cartridge door assembly](#)

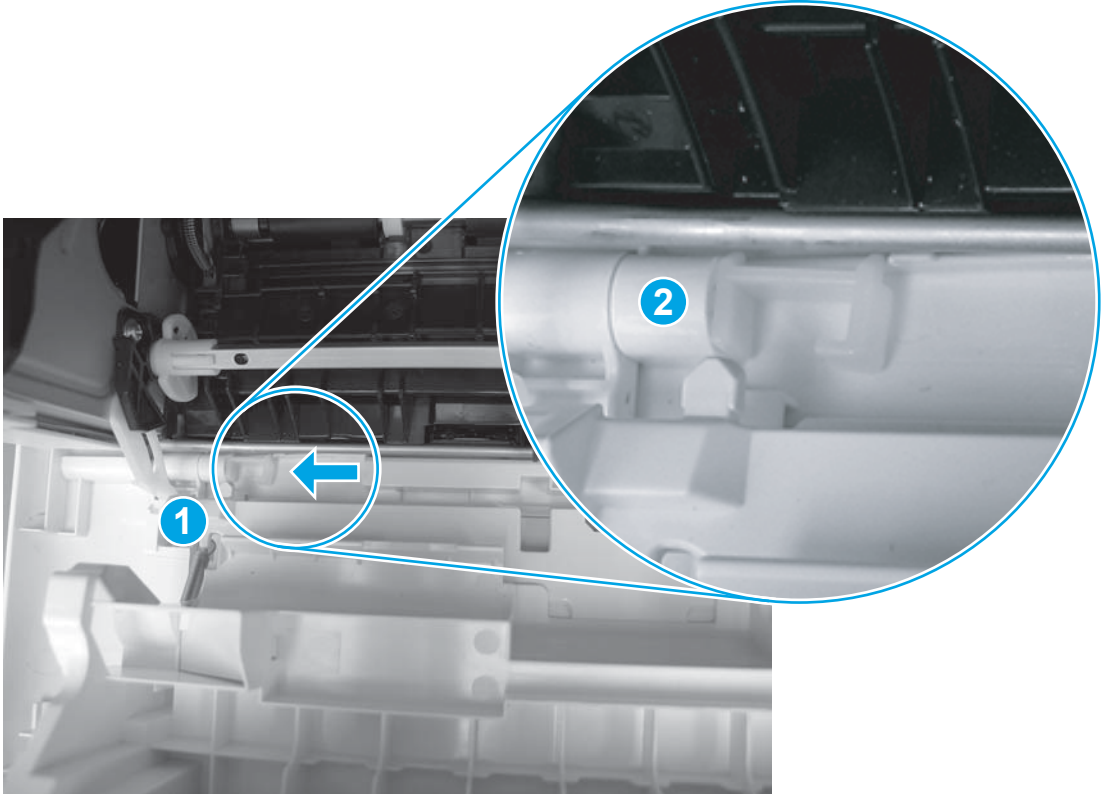
Introduction

This document provides the procedures to remove and replace the cartridge door assembly.

Before performing service

Turn the printer power off

- Disconnect the power cable.

 **WARNING!** To avoid damage to the printer, turn the printer off, wait 30 seconds, and then remove the power cable before attempting to service the printer.

Use the table below to identify the correct part number for your printer. To order the part, go to www.hp.com/buy/parts.

Cartridge door assembly part number	
RM2-5390-000CN	Cartridge door assembly (M403/M402 models)
RM2-5436-000CN	Cartridge door assembly (M403/M402 NFC models)
RM2-5408-000CN	Cartridge door assembly (M427/M426 models)
RM2-5435-000CN	Cartridge door assembly (M427/M426 NFC models)

Required tools

- Small flat-blade screwdriver.

After performing service

Turn the printer power on

- Connect the power cable.
- Use the power switch to turn the power on.

Post service test

Make sure that the cartridge door assembly correctly opens and closes.

Step 1: Remove the cartridge door assembly

 **NOTE:** If the toner cartridge was not removed prior to servicing the printer, remove it now.

1. Release one tab (callout 1), and then slide shaft (callout 2) in the direction the arrow indicates and remove it.

 **TIP:** It might be easier to release the support shaft by using a small flat-blade screwdriver.

Figure 1-69 Release the support shaft

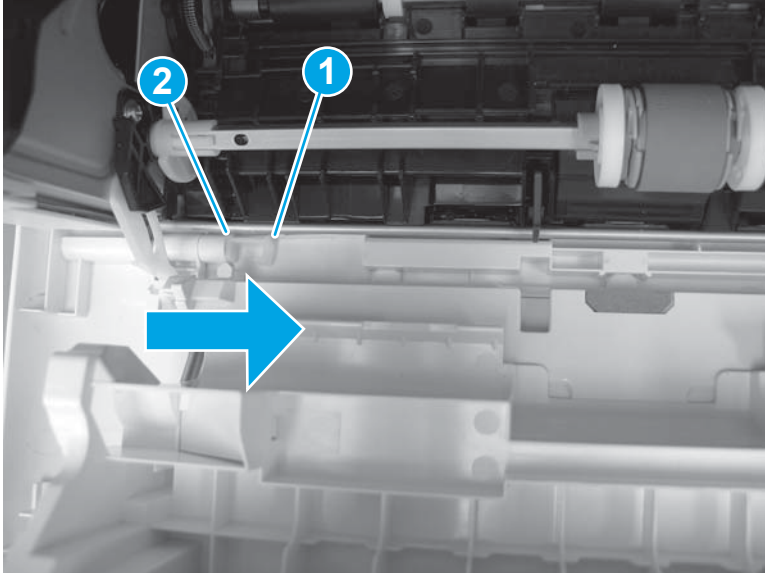

2. Release one tab (callout 1), and then slide the guide (callout 2) in the direction the arrow indicates and remove it.

Figure 1-70 Remove the guide

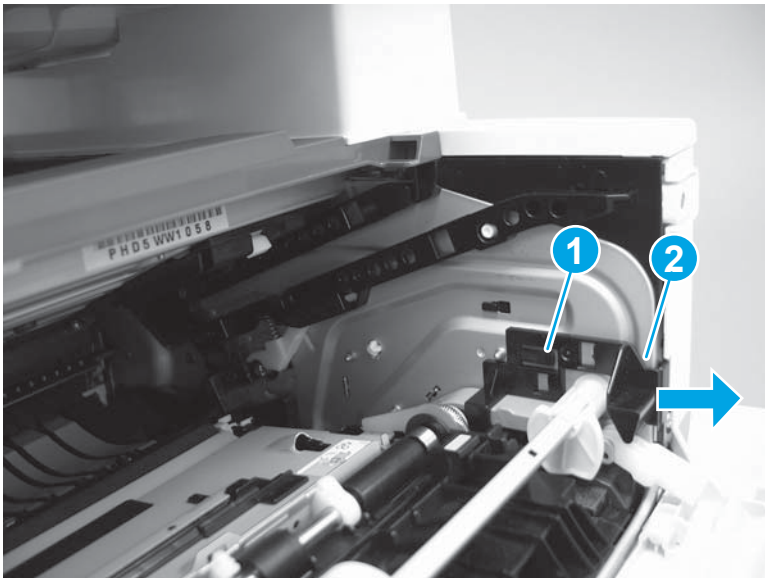

3. Remove the link arm (callout 1).

Figure 1-71 Remove the link arm

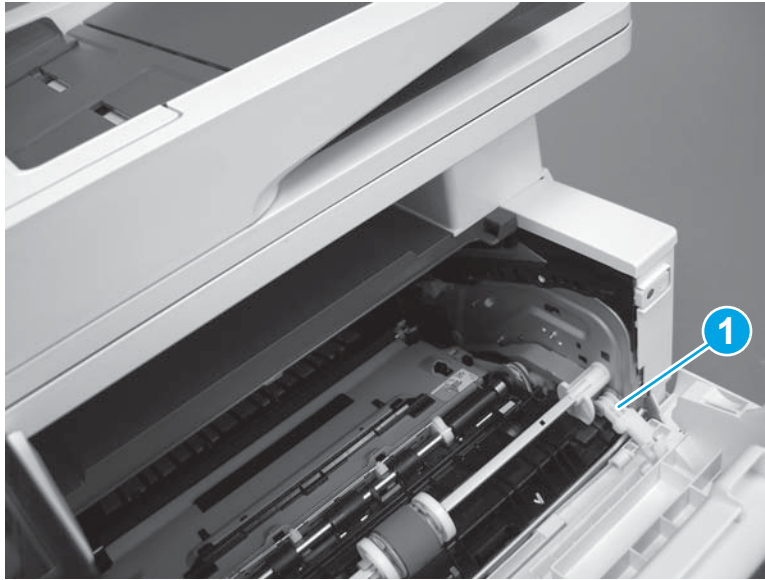

4. Slide the cartridge door assembly (callout 1) in the direction the arrow indicates and remove it.

Figure 1-72 Remove the door

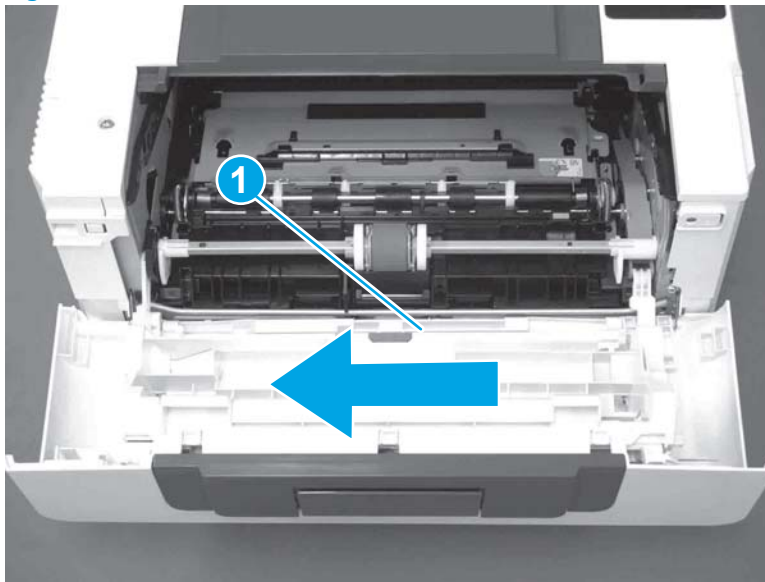

5. Remove the link (callout 1) from the cartridge door assembly (callout 2).

Figure 1-73 Release the left-side retainer arm

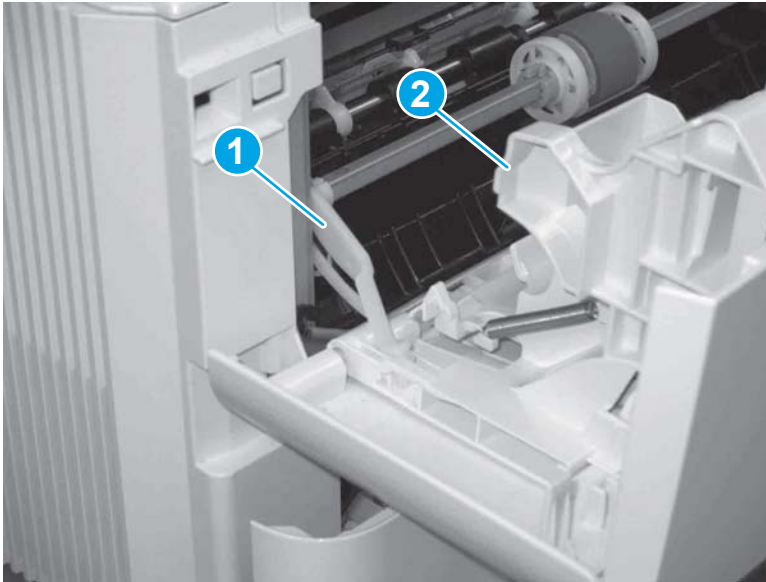

Step 2: Unpack the replacement assembly

Unpack the replacement part from the packaging.

<http://www8.hp.com/us/en/hp-information/environment/product-recycling.html>

 **NOTE:** HP recommends responsible disposal of the defective part.

Figure 1-74 Recycle and unpack

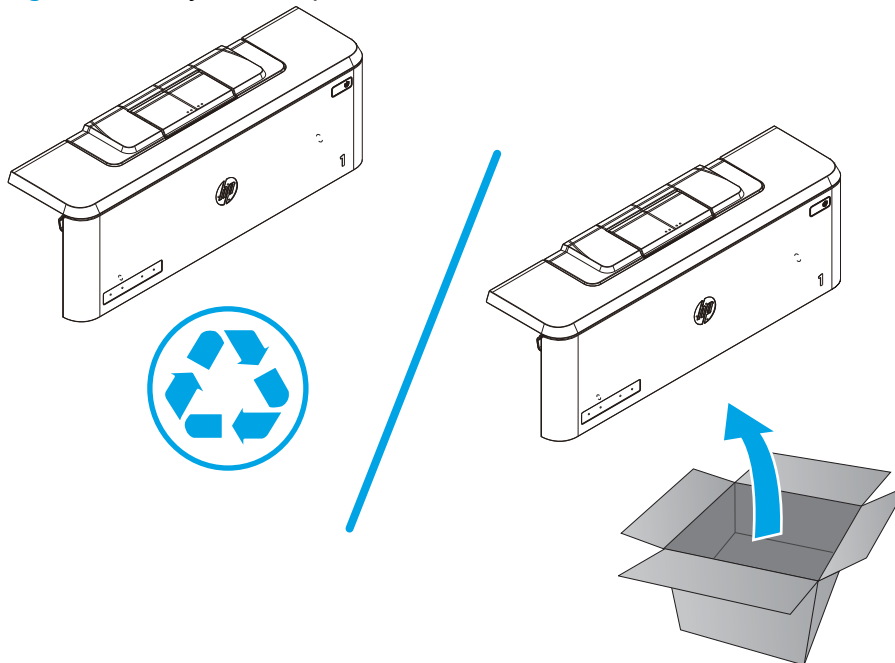

Step 3: Install the cartridge door assembly

 **Reinstallation tip:** After a replacement door is installed, make sure to install the nameplate (supplied in the kit) corresponding to the printer name on the door.

1. Position the door close to the printer, and then engage the keyed pin on the left-side retainer arm with the hole in the door.

Figure 1-75 Engage the left-side retainer arm

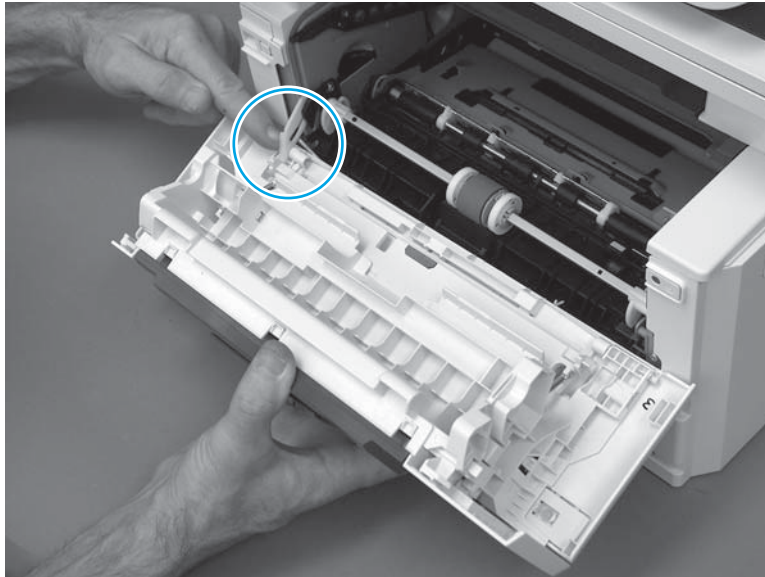

2. Engage the right-side door hinge pin with the hole in the chassis (callout 1).

Figure 1-76 Install the door

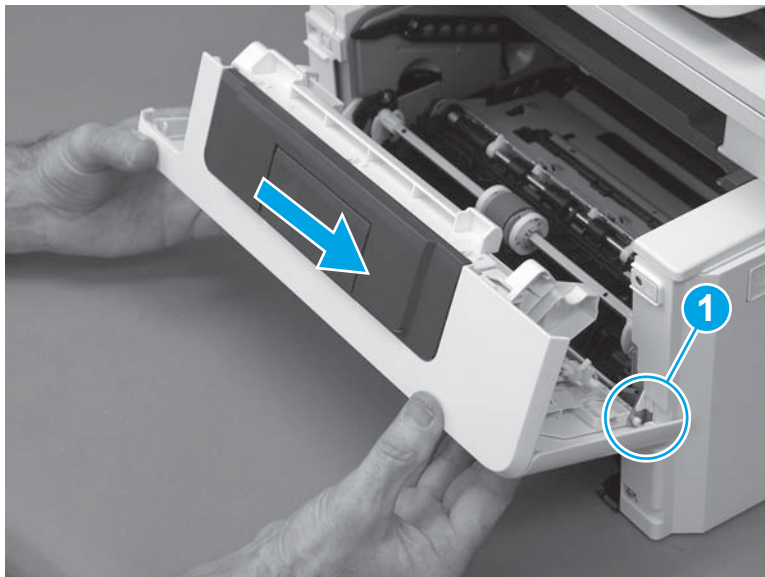

3. Install the link (callout 1).

 **IMPORTANT:** Make sure that the link snaps into place on the arm (callout 2). The link actuates the fuser pressure-release mechanism.

Figure 1-77 Install the pressure-release link

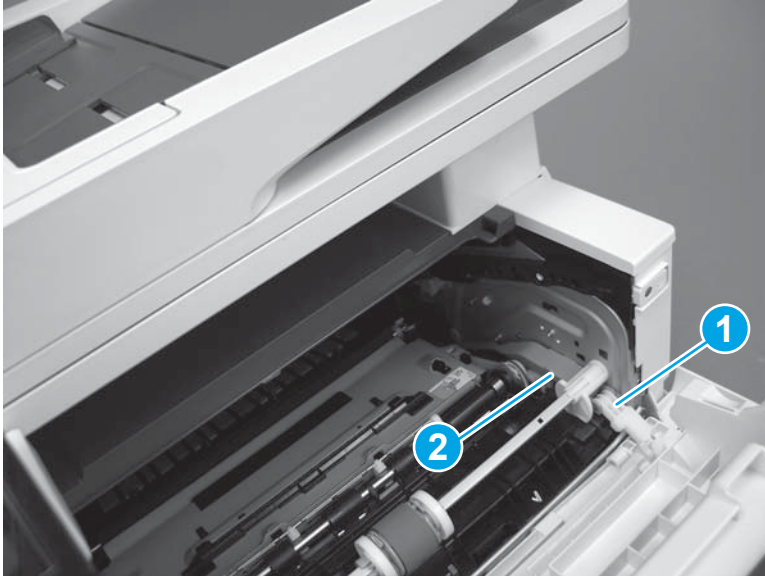

4. Slide the guide into the printer (callout 1), and then make sure that the tab (callout 2) snaps into place to secure the guide to the chassis.

Figure 1-78 Install the guide

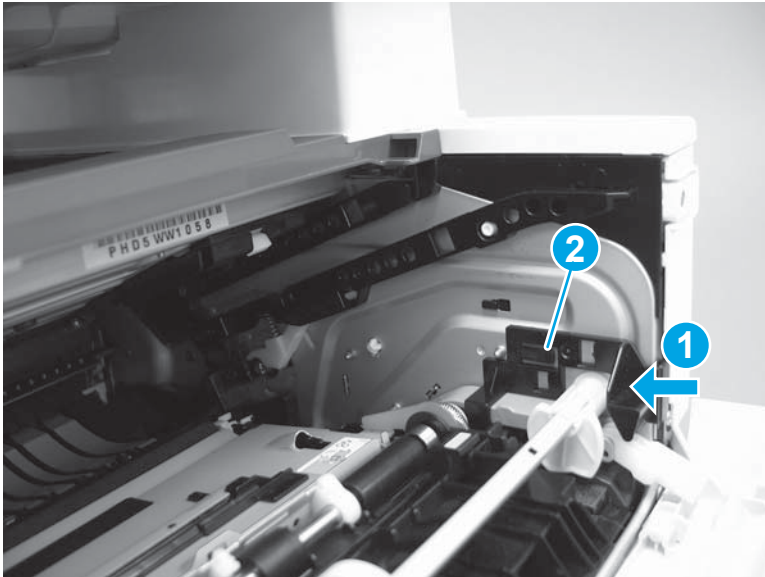

5. Position the shaft on the door, and then align the left-side hinge on the door with the hole in the chassis (callout 1).

Figure 1-79 Align the hinge

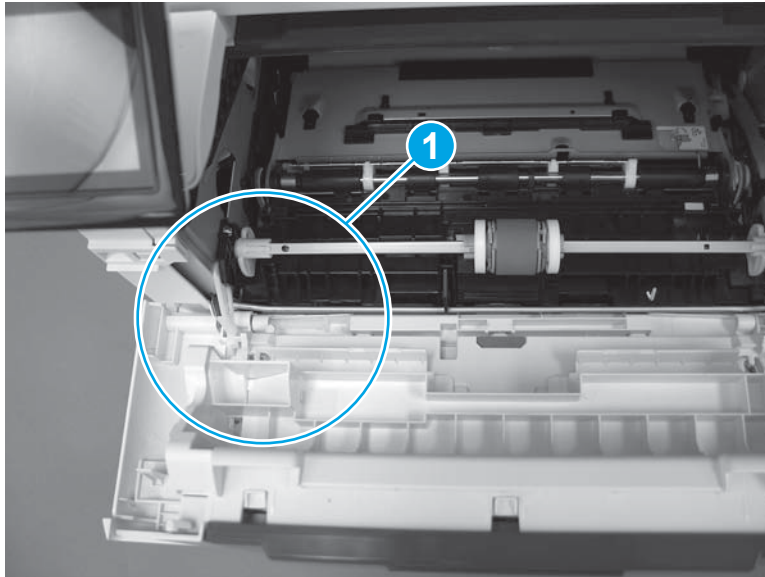

6. Push the shaft towards the left side of the printer to install it (callout 1).

 **Reinstallation tip:** Make sure that the support shaft is fully installed and correctly orientated (callout 2) so that it will not interfere with the door opening and closing.

Figure 1-80 Install the support shaft



Removal and replacement: Pressure-release link

- [Introduction](#)
- [Step 1: Remove the cartridge door assembly](#)
- [Step 2: Remove the pressure-release link](#)
- [Step 3: Unpack the replacement assembly](#)
- [Step 4: Install the pressure-release link](#)
- [Step 5: Install the cartridge door assembly](#)

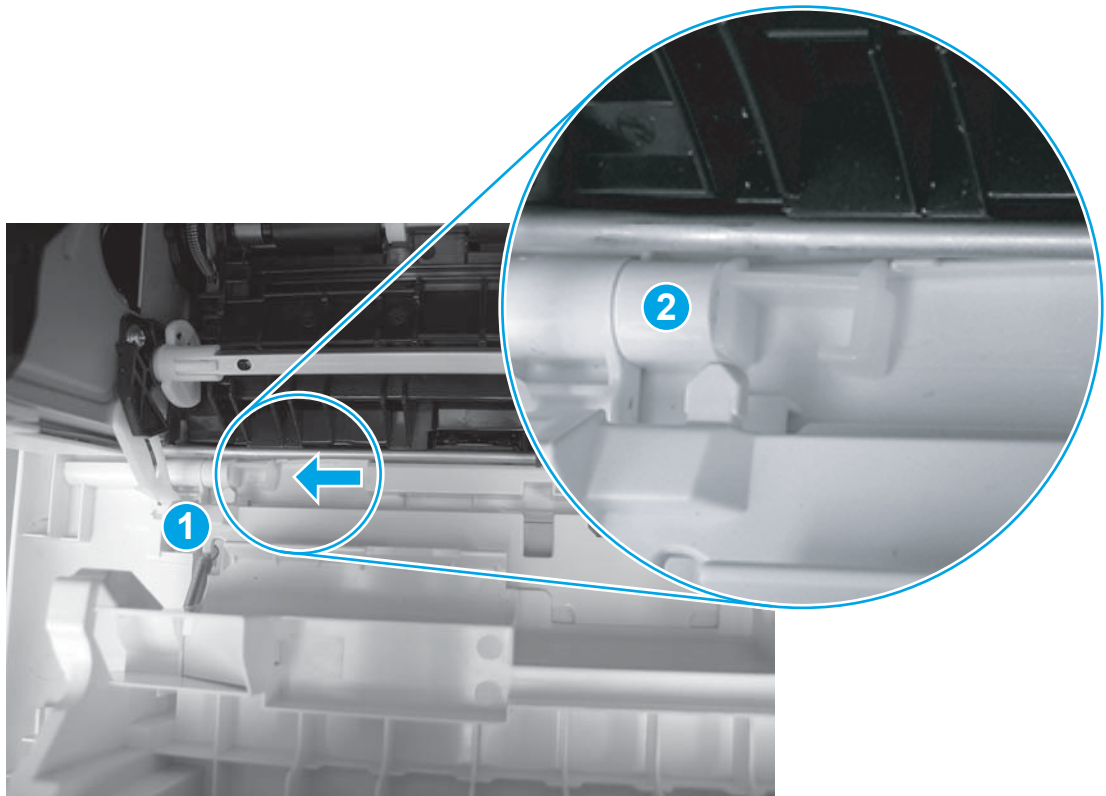
Introduction

This document provides the procedures to remove and replace the pressure-release link arm.

Before performing service

Turn the printer power off

- Disconnect the power cable.

 **WARNING!** To avoid damage to the printer, turn the printer off, wait 30 seconds, and then remove the power cable before attempting to service the printer.

Use the table below to identify the correct part number for your printer. To order the part, go to www.hp.com/buy/parts.

Pressure-release link part number	
RC4-4479-000CN	Link, pressure-release link

Required tools

- Small flat-blade screwdriver.

After performing service

Turn the printer power on

- Connect the power cable.
- Use the power switch to turn the power on.

Post service test

Make sure that the toner-cartridge door correctly opens and closes.

Step 1: Remove the cartridge door assembly

 **NOTE:** If the toner cartridge was not removed prior to servicing the printer, remove it now.

1. Release one tab (callout 1), and then slide shaft (callout 2) in the direction the arrow indicates and remove it.

 **TIP:** It might be easier to release the support shaft by using a small flat-blade screwdriver.

Figure 1-81 Release the support shaft

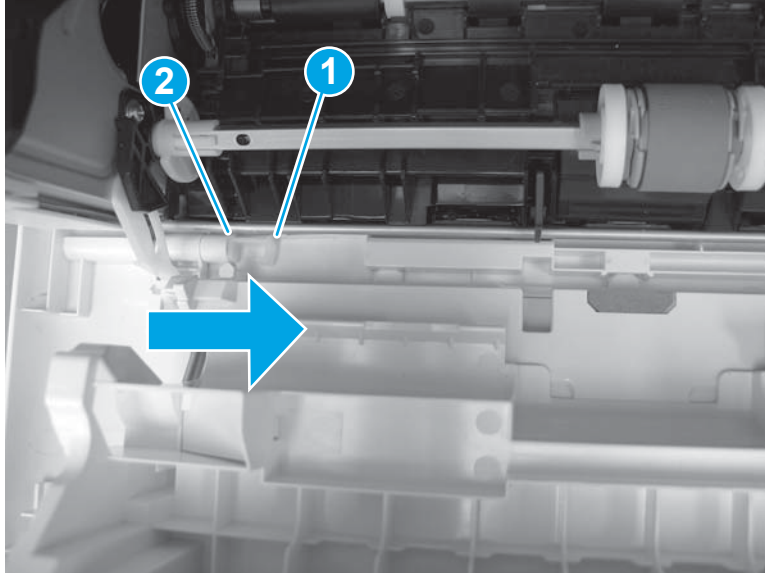

2. Release one tab (callout 1), and then slide the guide (callout 2) in the direction the arrow indicates and remove it.

Figure 1-82 Remove the guide



3. Remove the link arm (callout 1).

Figure 1-83 Remove the link arm

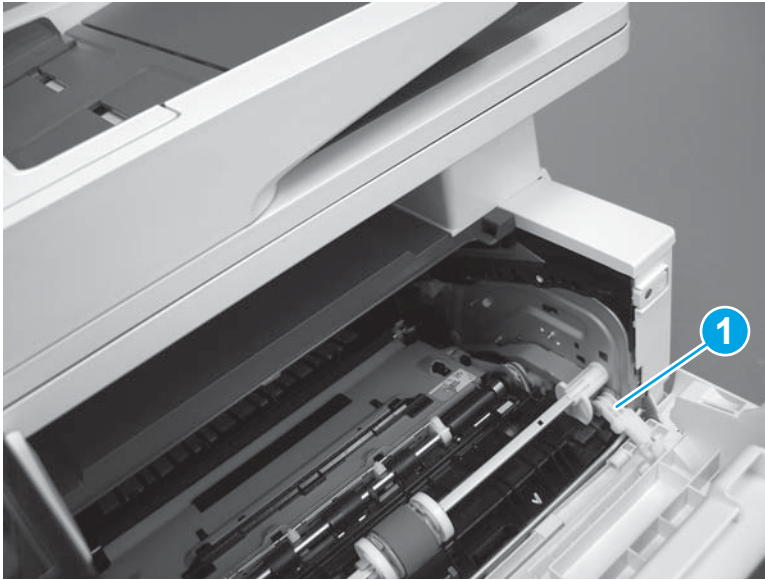

4. Slide the cartridge door assembly (callout 1) in the direction the arrow indicates and remove it.

Figure 1-84 Remove the door

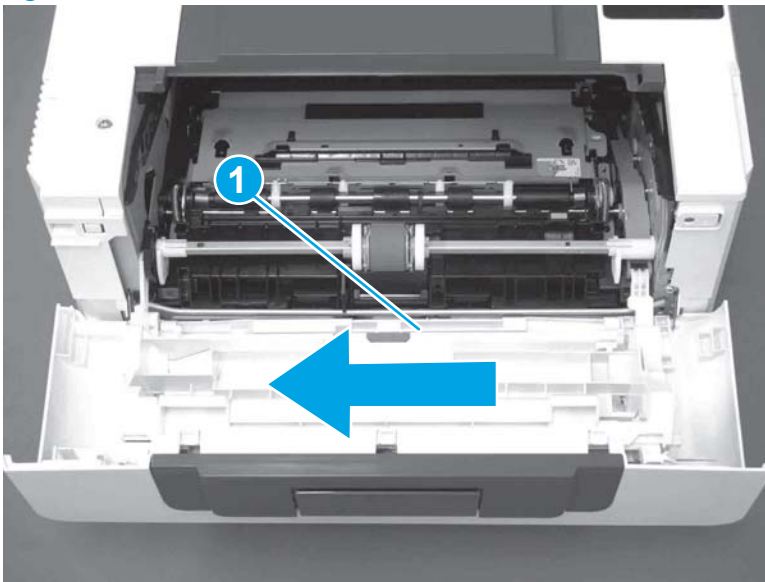

5. Remove the link (callout 1) from the cartridge door assembly (callout 2).

Figure 1-85 Release the left-side retainer arm

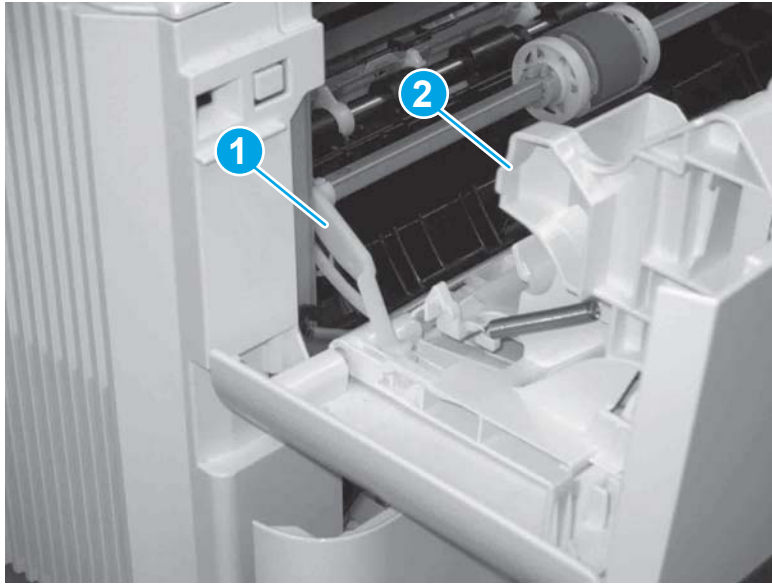

Step 2: Remove the pressure-release link

1. Rotate the pressure-release link until the keyed portion of the pin aligns with the slot in the holder.

Figure 1-86 Release the pressure-release link

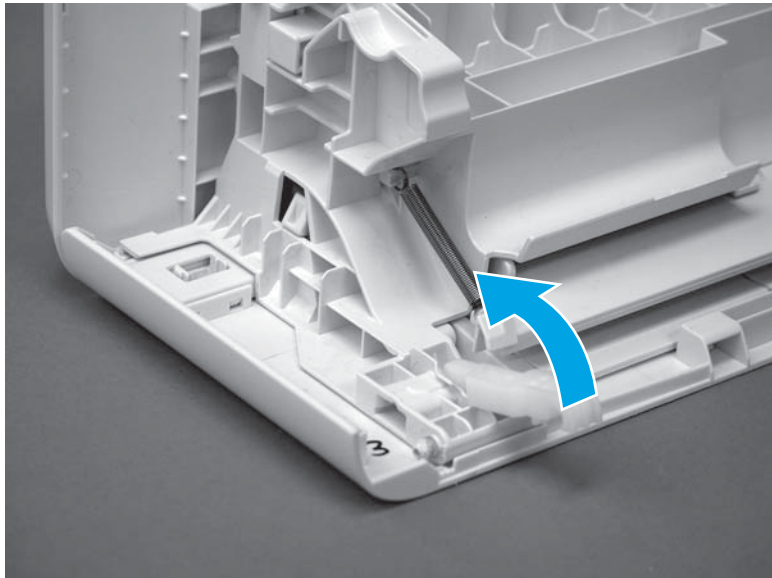

2. Remove the pressure-release link.

Figure 1-87 Remove the pressure-release link

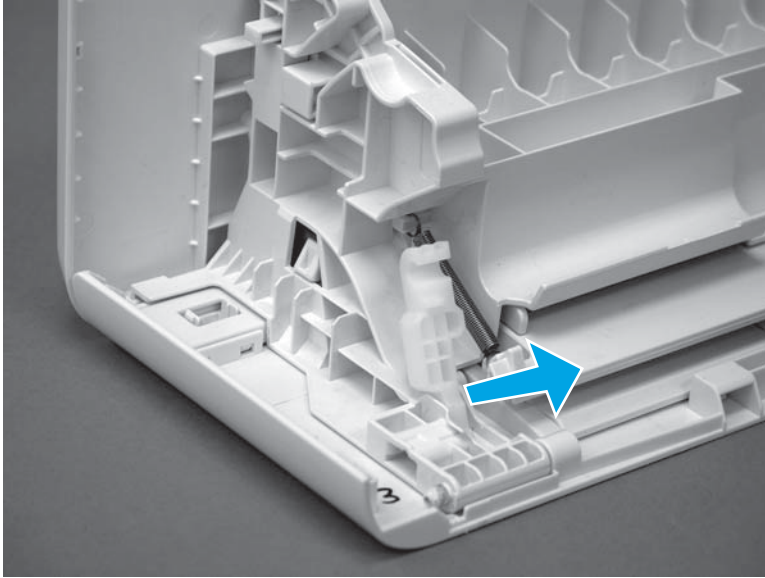

Step 3: Unpack the replacement assembly

Unpack the replacement part from the packaging.

<http://www8.hp.com/us/en/hp-information/environment/product-recycling.html>



NOTE: HP recommends responsible disposal of the defective part.

Figure 1-88 Recycle and unpack

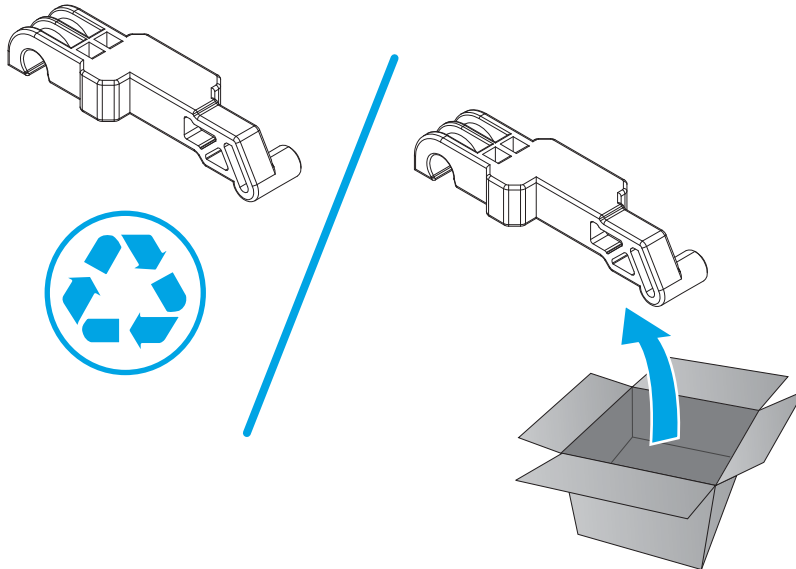

Step 4: Install the pressure-release link

1. Align the keyed portion of the pin with the slot in the holder, and then install the link.

Figure 1-89 Align the keyed portion of the pin

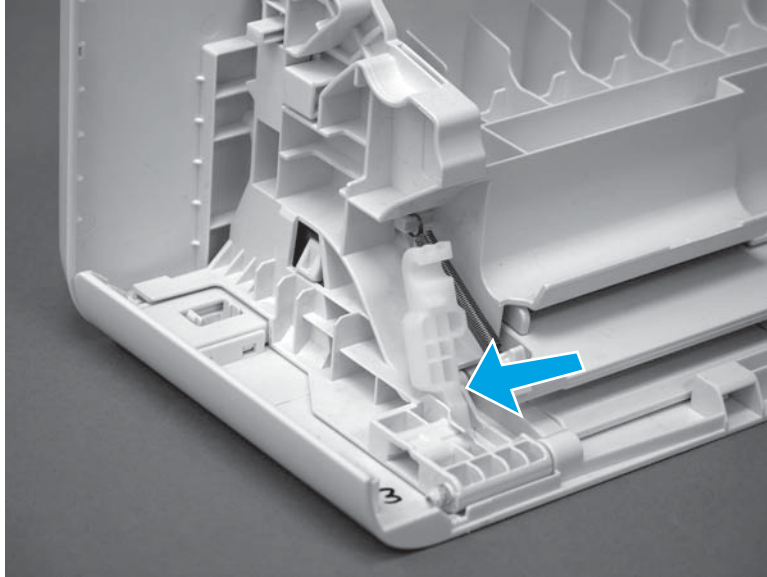

2. Rotate the pressure-release link to engage it with the door.

Figure 1-90 Install the pressure-release link

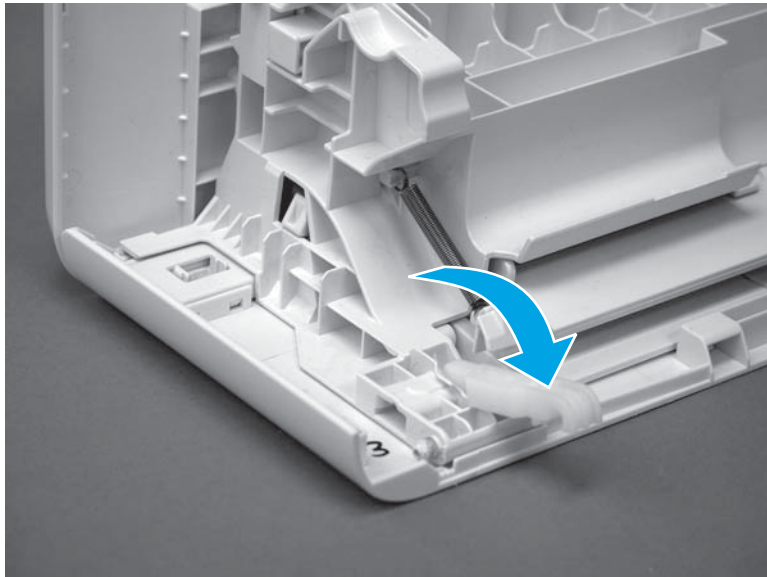

Step 5: Install the cartridge door assembly

 **Reinstallation tip:** After a replacement door is installed, make sure to install the nameplate (supplied in the kit) corresponding to the printer name on the door.

1. Position the door close to the printer, and then engage the keyed pin on the left-side retainer arm with the hole in the door.

Figure 1-91 Engage the left-side retainer arm

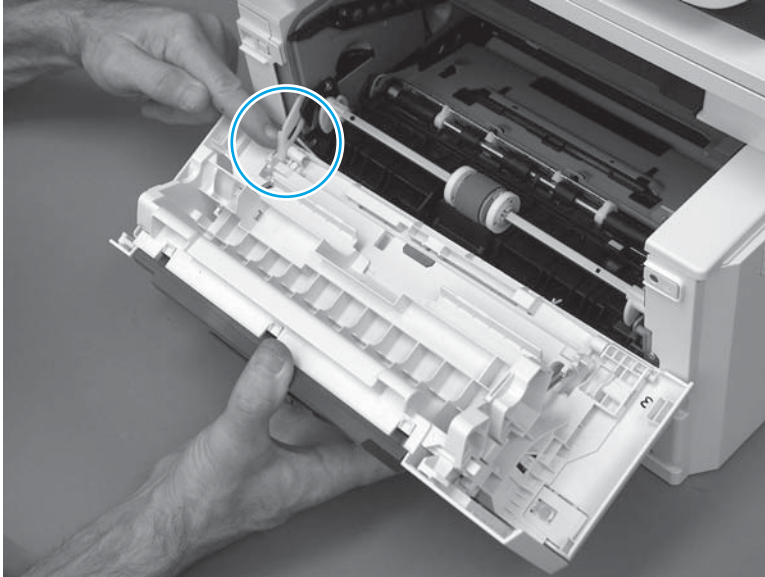

2. Engage the right-side door hinge pin with the hole in the chassis (callout 1).

Figure 1-92 Install the door

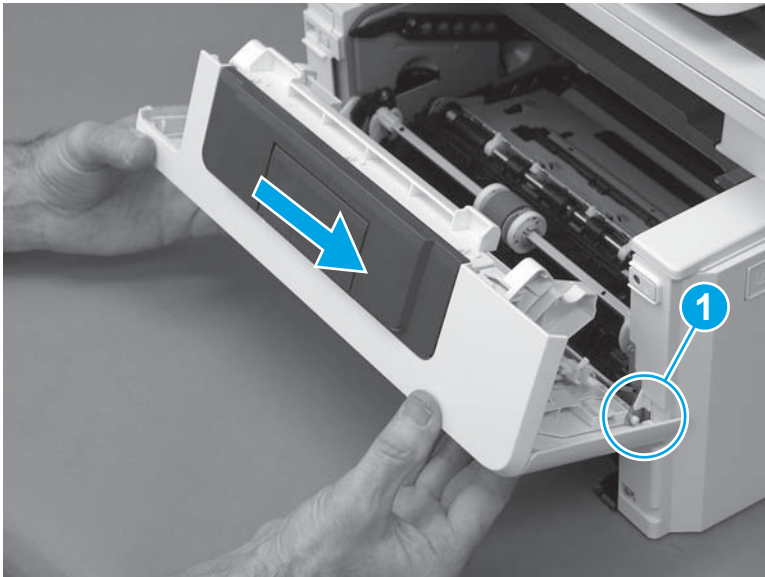

3. Install the link (callout 1).

 **IMPORTANT:** Make sure that the link snaps into place on the arm (callout 2). The link actuates the fuser pressure-release mechanism.

Figure 1-93 Install the pressure-release link

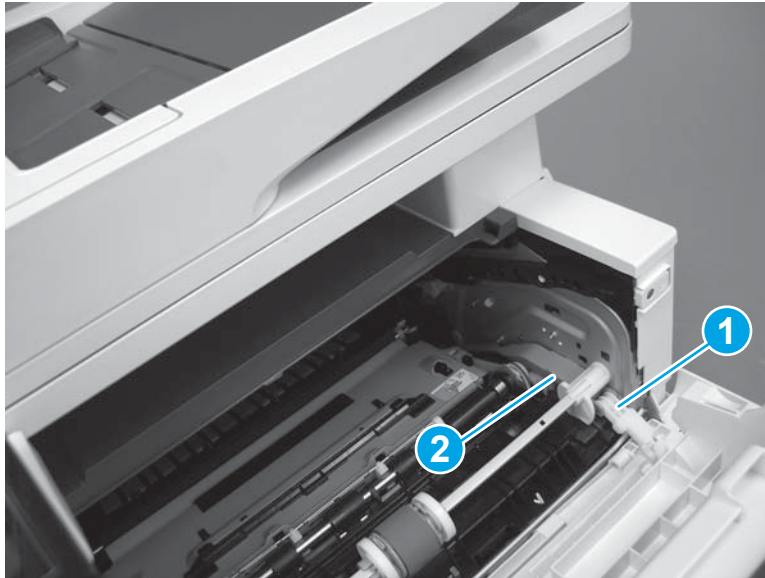

4. Slide the guide into the printer (callout 1), and then make sure that the tab (callout 2) snaps into place to secure the guide to the chassis.

Figure 1-94 Install the guide

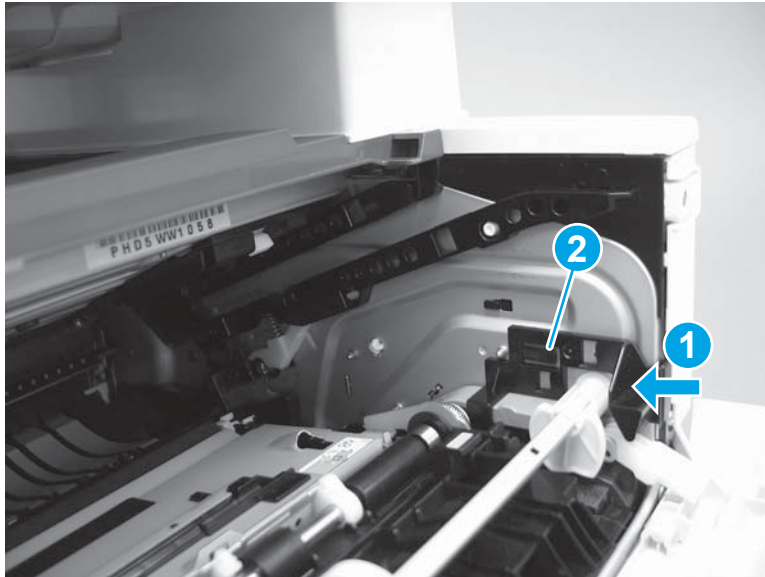

5. Position the shaft on the door, and then align the left-side hinge on the door with the hole in the chassis (callout 1).

Figure 1-95 Align the hinge

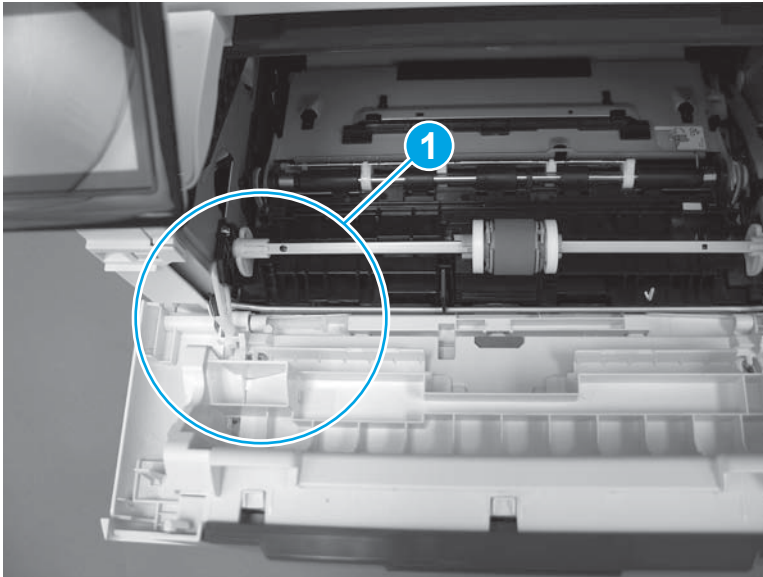

6. Push the shaft towards the left side of the printer to install it (callout 1).

 **Reinstallation tip:** Make sure that the support shaft is fully installed and correctly orientated (callout 2) so that it will not interfere with the door opening and closing.

Figure 1-96 Install the support shaft



Removal and replacement: Left cover

- [Introduction](#)
- [Step 1: Remove the rear USB cover](#)
- [Step 2: Remove the rear network cover \(M402d and M403d\)](#)
- [Step 3: Remove Tray 2](#)
- [Step 4: Remove the cartridge door assembly](#)
- [Step 5: Remove the left cover](#)
- [Step 6: Unpack the replacement assembly](#)
- [Step 7: Install the left cover](#)
- [Step 8: Install the cartridge door assembly](#)
- [Step 9: Install Tray 2](#)
- [Step 10: Install the rear network cover \(M402d and M403d\)](#)
- [Step 11: Install the rear USB cover](#)

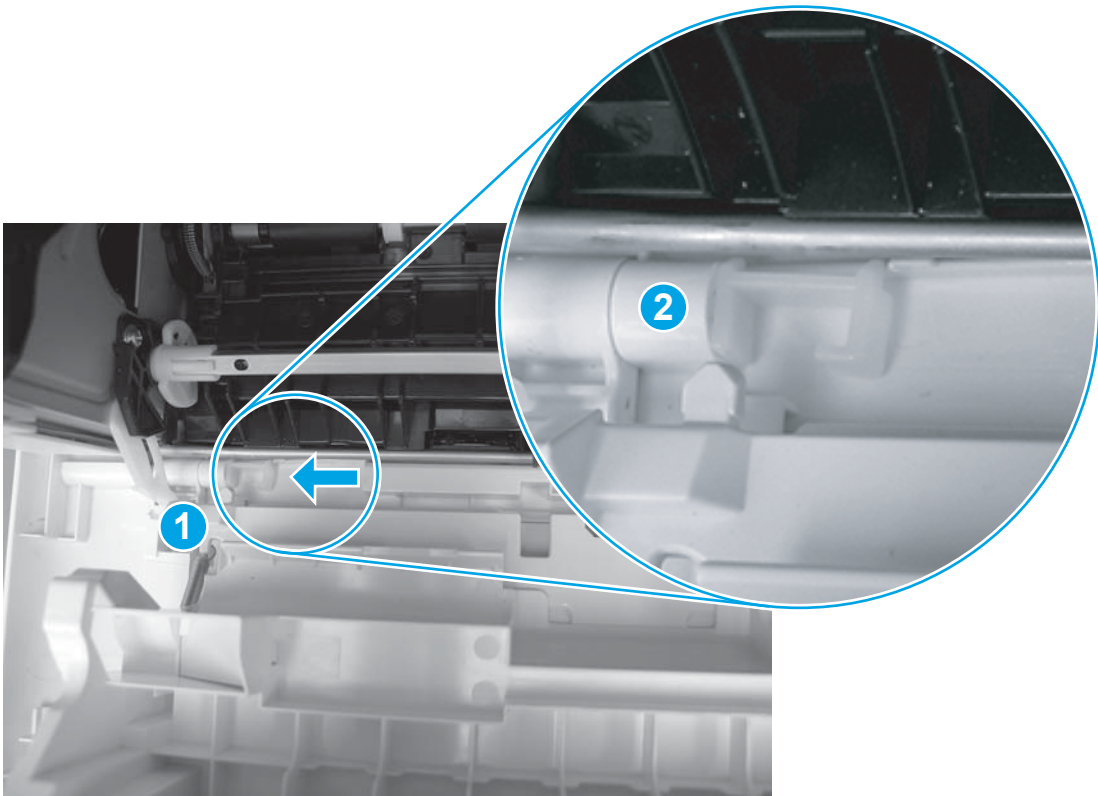
Introduction

This document provides the procedures to remove and replace the left cover.

Before performing service

Turn the printer power off

- Disconnect the power cable.

 **WARNING!** To avoid damage to the printer, turn the printer off, wait 30 seconds, and then remove the power cable before attempting to service the printer.

Use the table below to identify the correct part number for your printer. To order the part, go to www.hp.com/buy/parts.

Left cover part number	
RL2-0673-000CN	Left cover (M403/M402 models)
RL2-0674-000CN	Left cover (M427/M426 models)

Required tools

- #2 Phillips screwdriver with a magnetic tip.

After performing service

Turn the printer power on

- Connect the power cable.
- Use the power switch to turn the power on.

Post service test

Make sure that the printer initializes to a **Ready** state.

Step 1: Remove the rear USB cover

1. Use a finger to release two tabs (callout 1), and then pull the cover straight off of the printer.

Figure 1-97 Pull the cover straight off

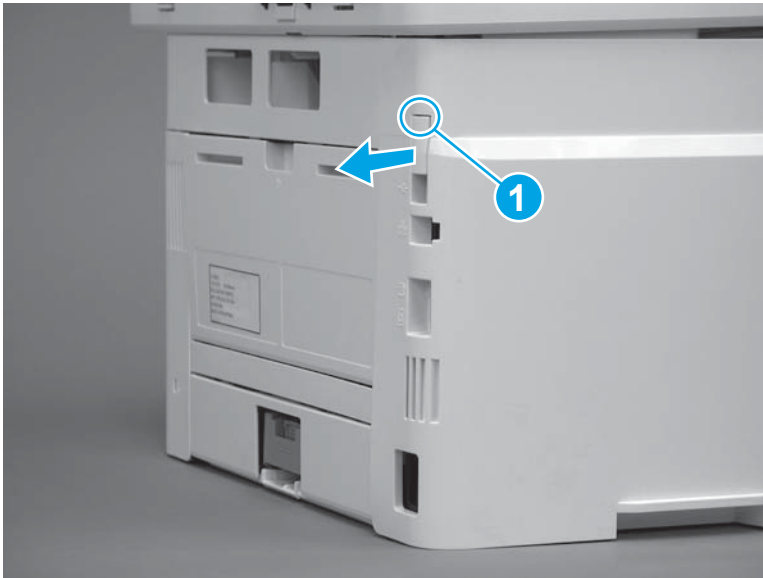

2. Remove the cover.

 **NOTE:** For network models, also remove the network port cover (not shown; RC4-2907-000CN).

Figure 1-98 Remove the cover



Step 2: Remove the rear network cover (M402d and M403d)

M402d and M403d only.

- ▲ Grasp the network cover (callout 1) and pull the cover straight off of the printer.

Figure 1-99 Pull the cover straight off

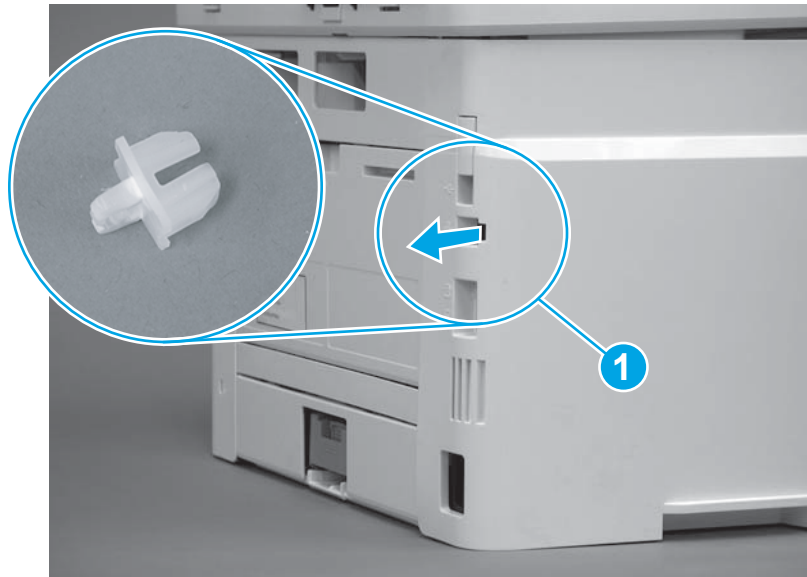

Step 3: Remove Tray 2

- ▲ Pull the tray straight out of the printer to remove it.

Figure 1-100 Remove the tray



Step 4: Remove the cartridge door assembly



NOTE: If the toner cartridge was not removed prior to servicing the printer, remove it now.

1. Release one tab (callout 1), and then slide shaft (callout 2) in the direction the arrow indicates and remove it.



TIP: It might be easier to release the support shaft by using a small flat-blade screwdriver.

Figure 1-101 Release the support shaft

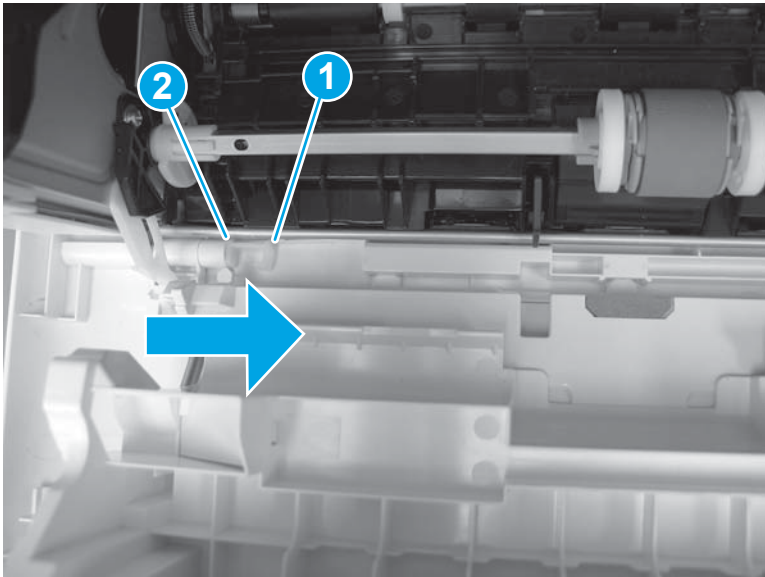

2. Release one tab (callout 1), and then slide the guide (callout 2) in the direction the arrow indicates and remove it.

Figure 1-102 Remove the guide

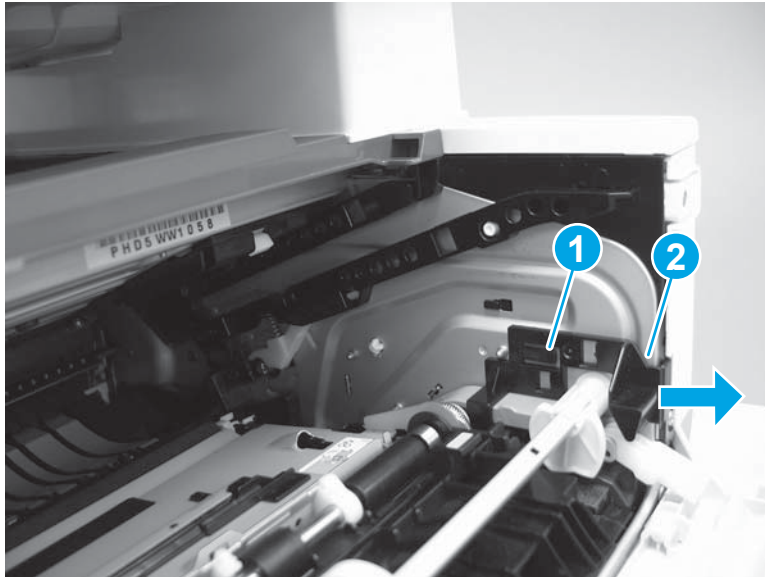

3. Remove the link arm (callout 1).

Figure 1-103 Remove the link arm

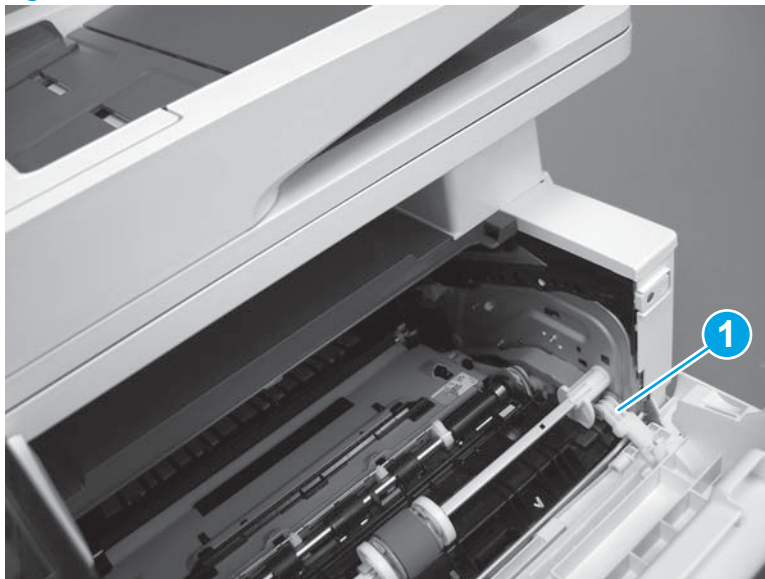

4. Slide the cartridge door assembly (callout 1) in the direction the arrow indicates and remove it.

Figure 1-104 Remove the door

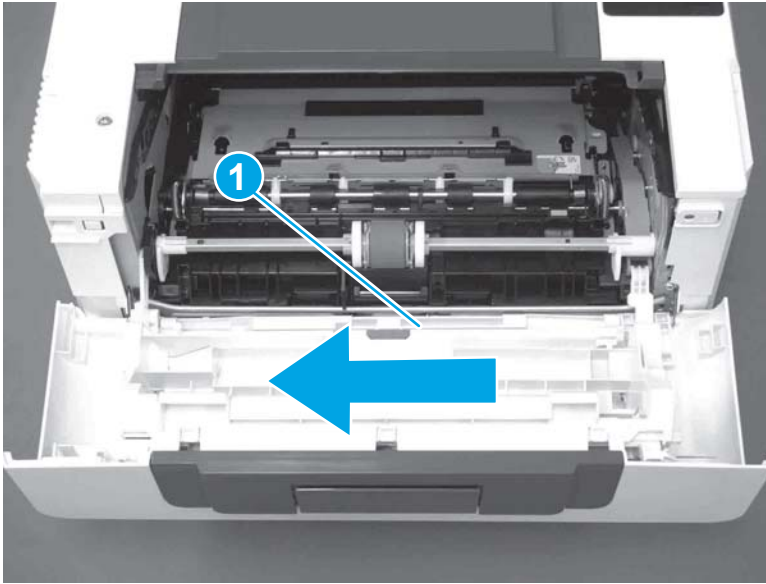

5. Remove the link (callout 1) from the cartridge door assembly (callout 2).

Figure 1-105 Release the left-side retainer arm

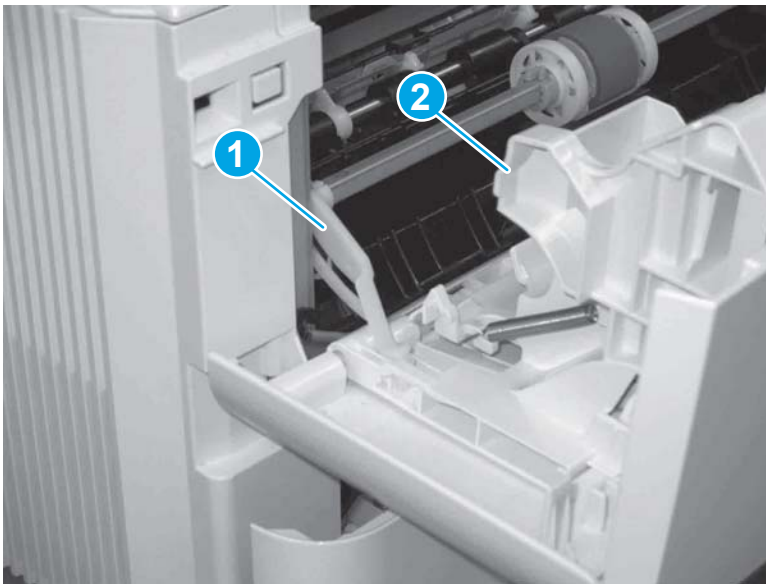

Step 5: Remove the left cover

1. Remove one screw (callout 1).

Figure 1-106 Remove one screw

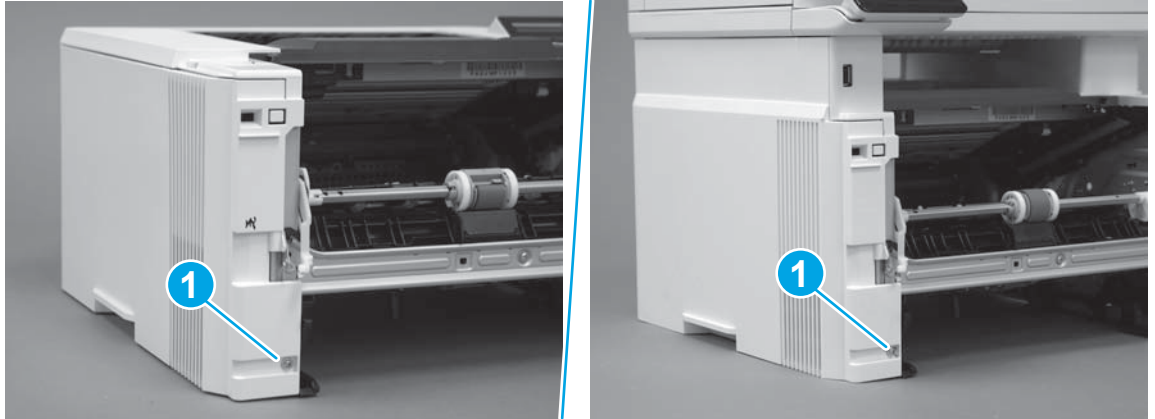

2. Open the rear door, release two bosses (callout 1), and then release three tabs (callout 2).

Figure 1-107 Release two bosses and three tabs

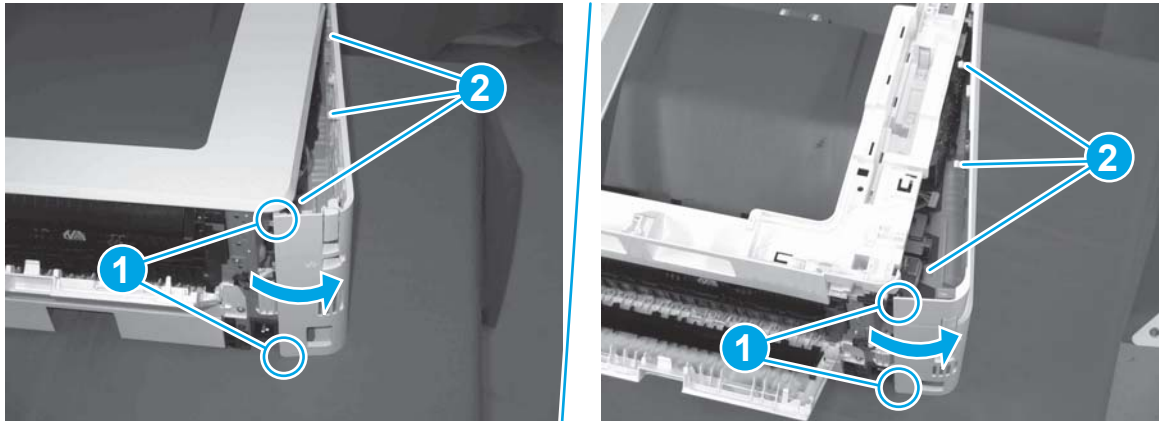

3. At the front of the printer, do one of the following:
 - **M403/M402:** Release two bosses (callout 1), and then remove the cover (callout 2).
 - **M427/M426:** Release one tab (callout 3), two bosses (callout 4), and then remove the cover (callout 5).

CAUTION: Be careful when releasing the upper bosses on the M427/M426 cover. One portion of the cover (callout 6) is fragile and is easily broken.

Figure 1-108 Remove the cover

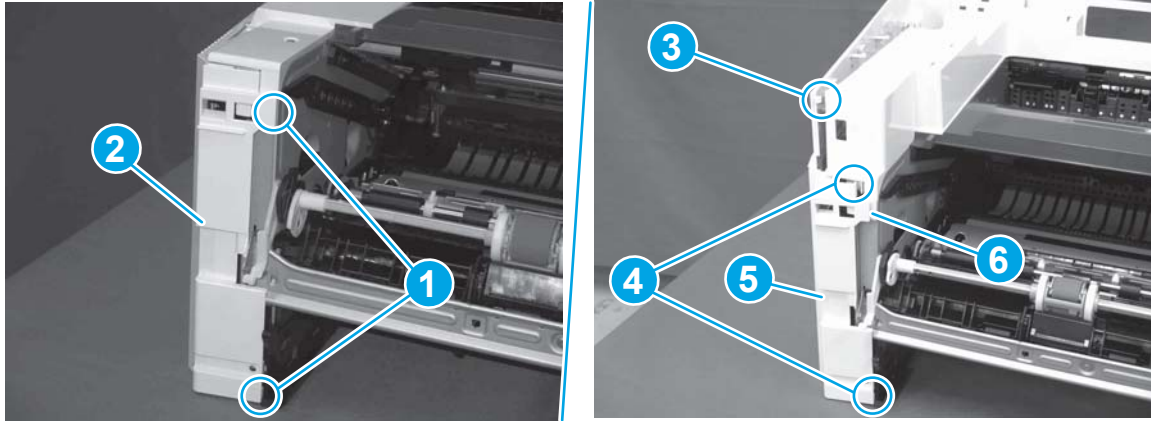

Step 6: Unpack the replacement assembly

Unpack the replacement part from the packaging.

<http://www8.hp.com/us/en/hp-information/environment/product-recycling.html>

 **NOTE:** HP recommends responsible disposal of the defective part.

Figure 1-109 Recycle and unpack

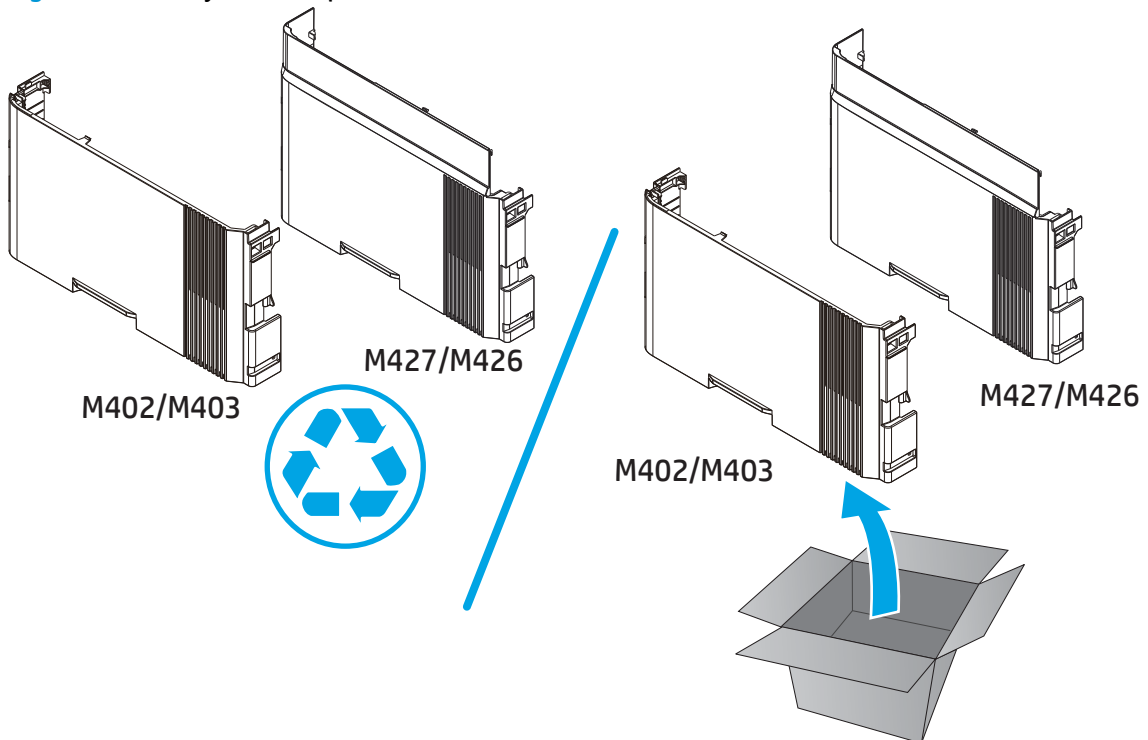

Step 7: Install the left cover

1. At the front of the printer, do one of the following:

- **M403/M402:** Position the cover on the printer (callout 1), and then engage two bosses (callout 2).
- **M427/M426:** Position the cover on the printer (callout 3), engage one tab (callout 4), and then engage two bosses (callout 4).

Figure 1-110 Install the cover

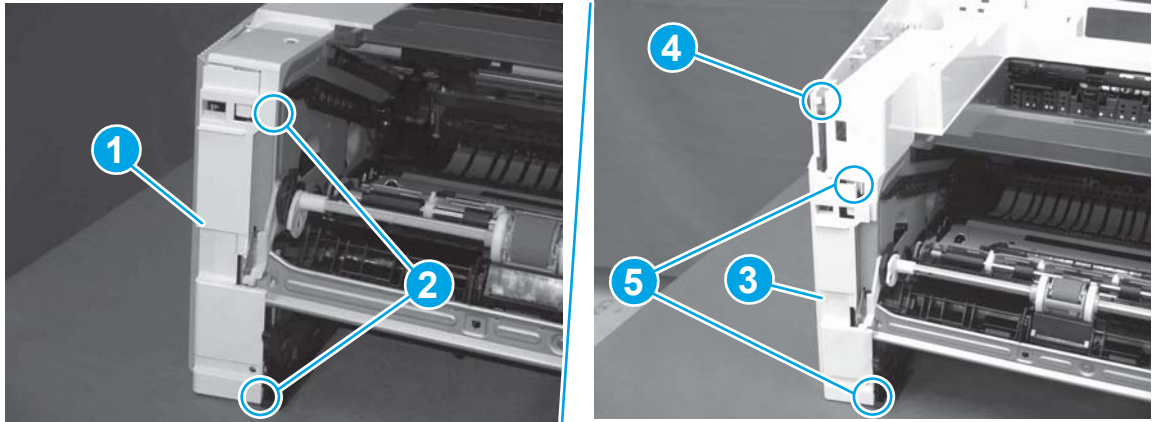

2. Carefully rotate the rear of the cover onto the printer (callout 1), engage three tabs (callout 2), and then engage two bosses (callout 3).

Figure 1-111 Engage three tabs and two bosses

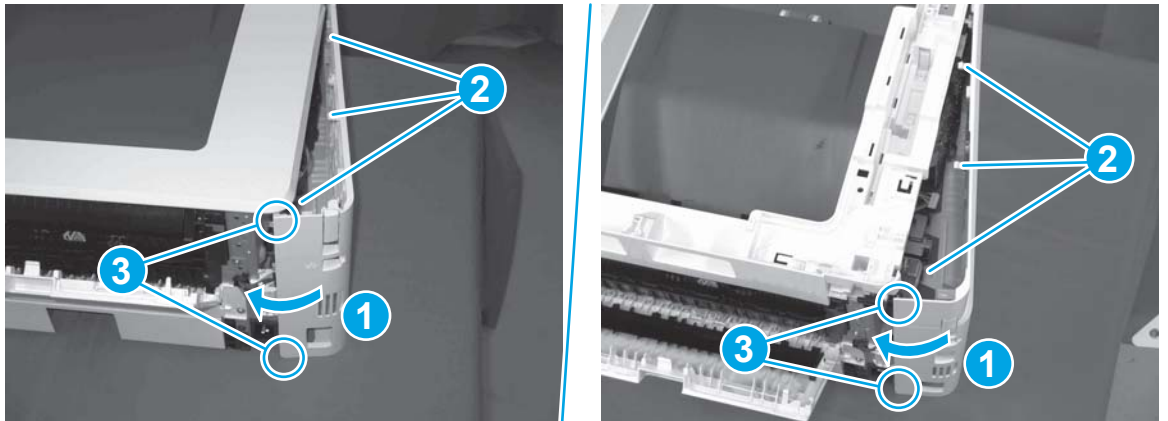

3. Install one screw (callout 1).

Figure 1-112 Install one screw

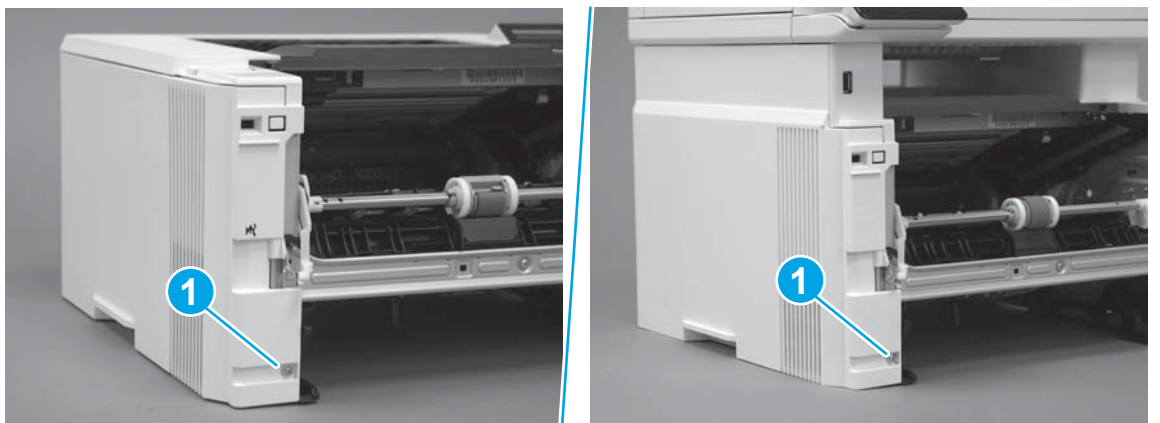

Step 8: Install the cartridge door assembly

 **Reinstallation tip:** After a replacement door is installed, make sure to install the nameplate (supplied in the kit) corresponding to the printer name on the door.

1. Position the door close to the printer, and then engage the keyed pin on the left-side retainer arm with the hole in the door.

Figure 1-113 Engage the left-side retainer arm

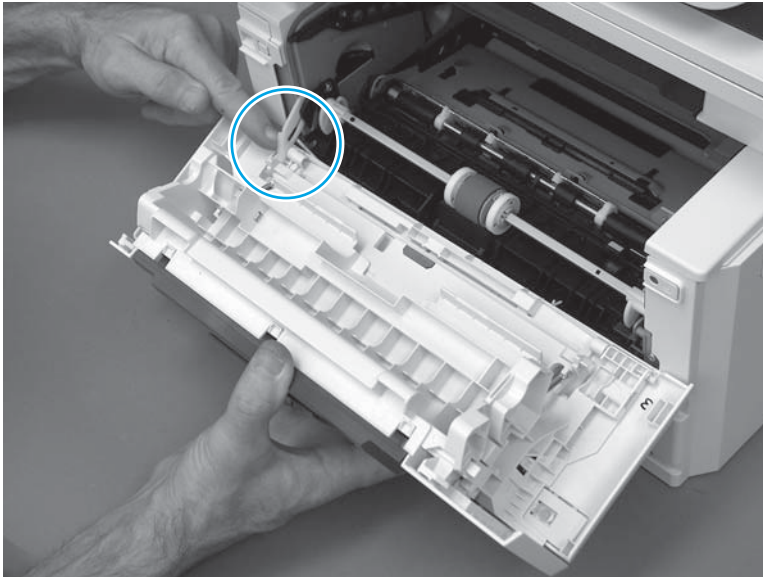

2. Engage the right-side door hinge pin with the hole in the chassis (callout 1).

Figure 1-114 Install the door

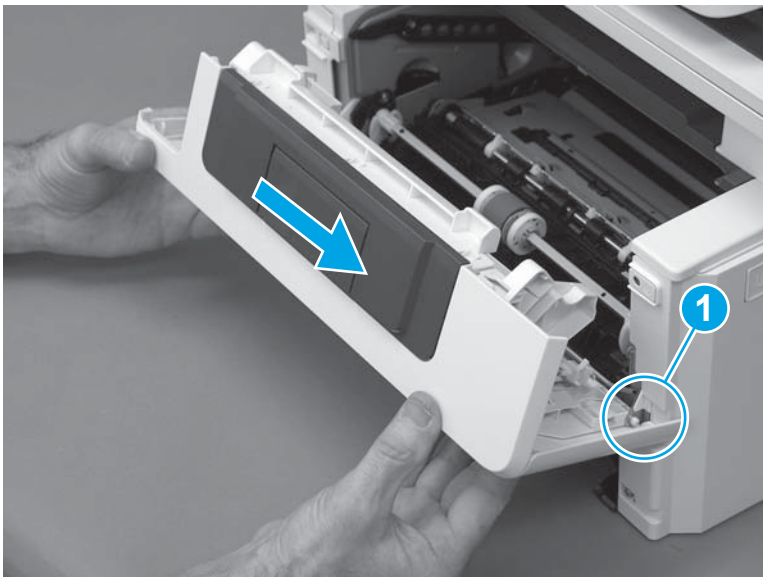

3. Install the link (callout 1).

 **IMPORTANT:** Make sure that the link snaps into place on the arm (callout 2). The link actuates the fuser pressure-release mechanism.

Figure 1-115 Install the pressure-release link

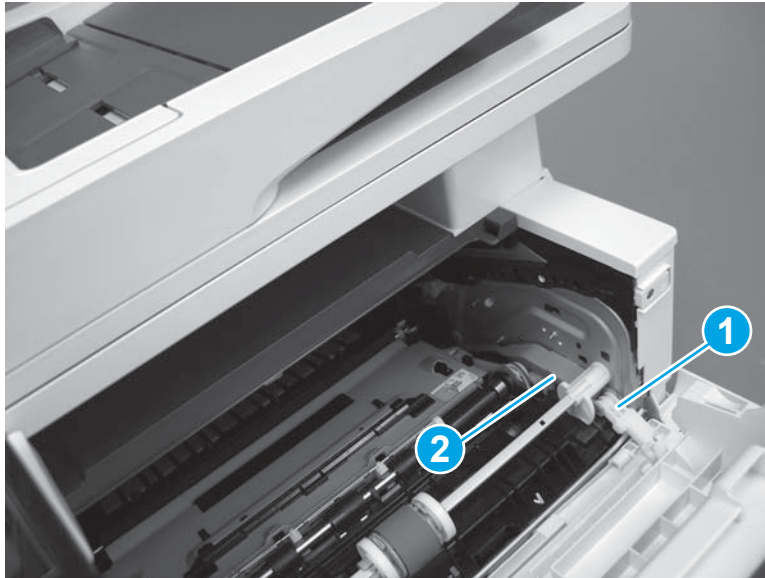

4. Slide the guide into the printer (callout 1), and then make sure that the tab (callout 2) snaps into place to secure the guide to the chassis.

Figure 1-116 Install the guide

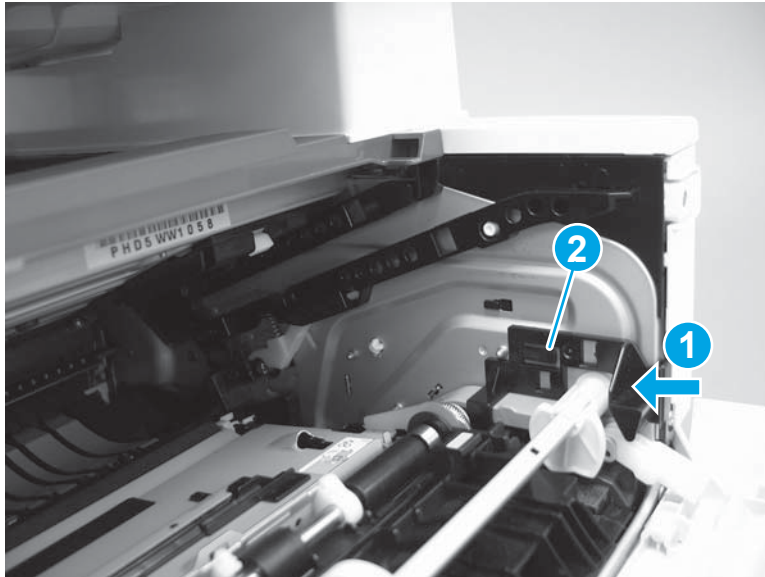

5. Position the shaft on the door, and then align the left-side hinge on the door with the hole in the chassis (callout 1).

Figure 1-117 Align the hinge

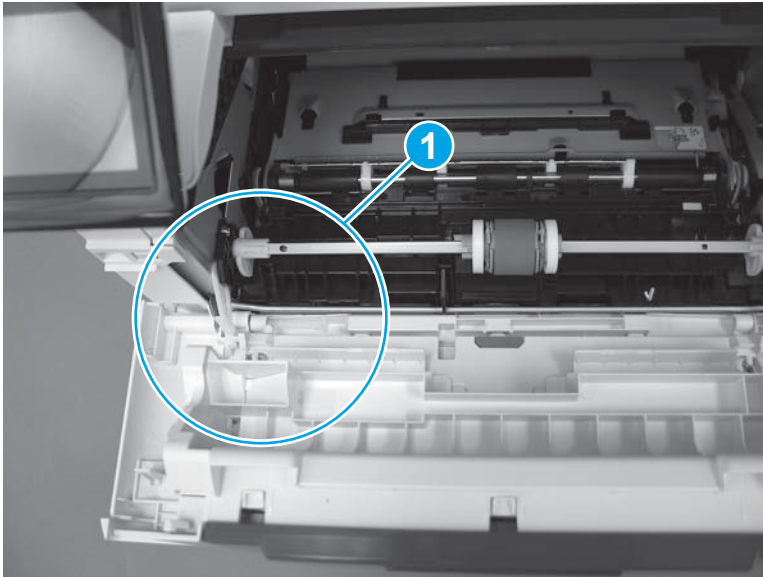

6. Push the shaft towards the left side of the printer to install it (callout 1).

 **Reinstallation tip:** Make sure that the support shaft is fully installed and correctly orientated (callout 2) so that it will not interfere with the door opening and closing.

Figure 1-118 Install the support shaft



Step 9: Install Tray 2

- ▲ Slide the tray straight into the printer to install it.

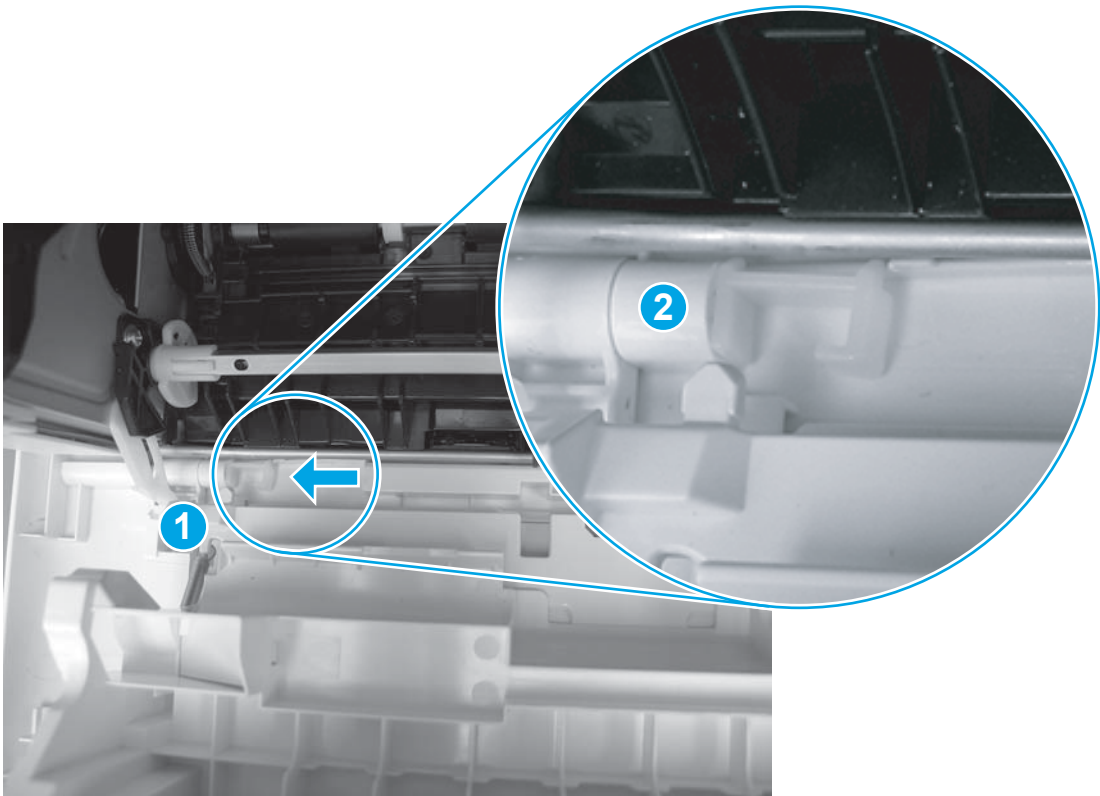
Figure 1-119 Install the tray



Step 10: Install the rear network cover (M402d and M403d)

M402d and M403d only.

- ▲ Push the cover straight on to the printer to install it.

Figure 1-120 Install the cover

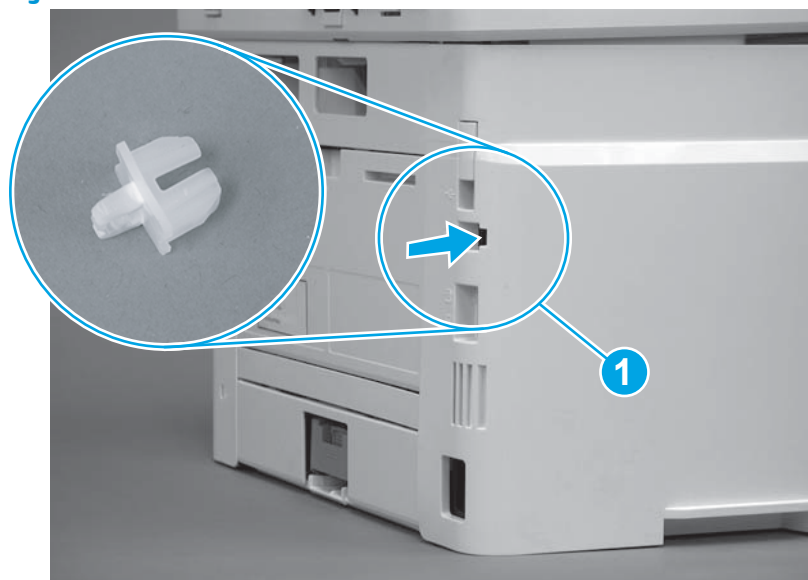

Step 11: Install the rear USB cover

1. Align the tabs on the cover with the slots in the left cover.

Figure 1-121 Align the tabs on the cover



2. Push the cover straight on to the printer to install it.



NOTE: For network models, also install the network port cover (not shown; RC4-2907-000CN).

Figure 1-122 Install the cover

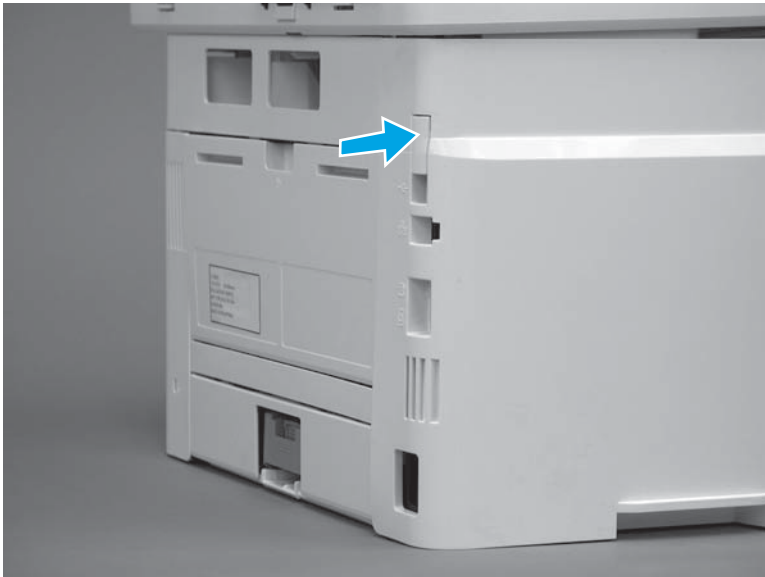

Removal and replacement: Right cover

- [Introduction](#)
- [Step 1: Remove Tray 2](#)
- [Step 2: Remove the cartridge door assembly](#)
- [Step 3: Remove the right cover](#)
- [Step 4: Unpack the replacement assembly](#)
- [Step 5: Install the right cover](#)
- [Step 6: Install the cartridge door assembly](#)
- [Step 7: Install Tray 2](#)

Introduction

This document provides the procedures to remove and replace the right cover.

Before performing service

Turn the printer power off

- Disconnect the power cable.

 **WARNING!** To avoid damage to the printer, turn the printer off, wait 30 seconds, and then remove the power cable before attempting to service the printer.

Use the table below to identify the correct part number for your printer. To order the part, go to www.hp.com/buy/parts.

Right cover part number	
RM2-5434-000CN	Right cover

Required tools

- #2 Phillips screwdriver with a magnetic tip.

After performing service

Turn the printer power on

- Connect the power cable.
- Use the power switch to turn the power on.

Post service test

Make sure that the printer initializes to a **Ready** state.

Step 1: Remove Tray 2

- ▲ Pull the tray straight out of the printer to remove it.

Figure 1-123 Remove the tray



Step 2: Remove the cartridge door assembly



NOTE: If the toner cartridge was not removed prior to servicing the printer, remove it now.

1. Release one tab (callout 1), and then slide shaft (callout 2) in the direction the arrow indicates and remove it.



TIP: It might be easier to release the support shaft by using a small flat-blade screwdriver.

Figure 1-124 Release the support shaft

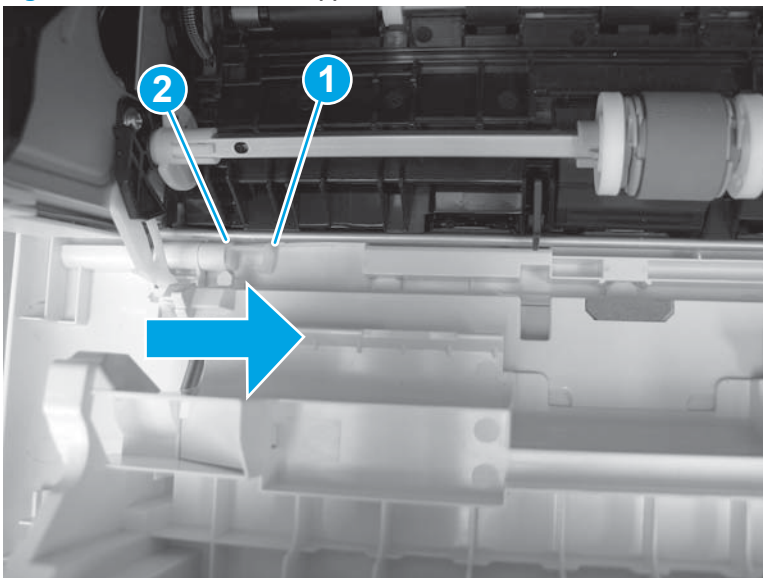

2. Release one tab (callout 1), and then slide the guide (callout 2) in the direction the arrow indicates and remove it.

Figure 1-125 Remove the guide



3. Remove the link arm (callout 1).

Figure 1-126 Remove the link arm

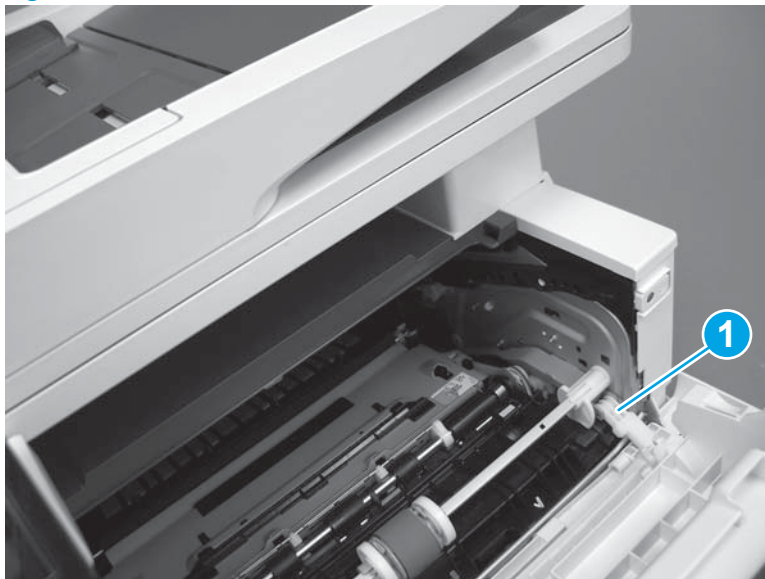

4. Slide the cartridge door assembly (callout 1) in the direction the arrow indicates and remove it.

Figure 1-127 Remove the door

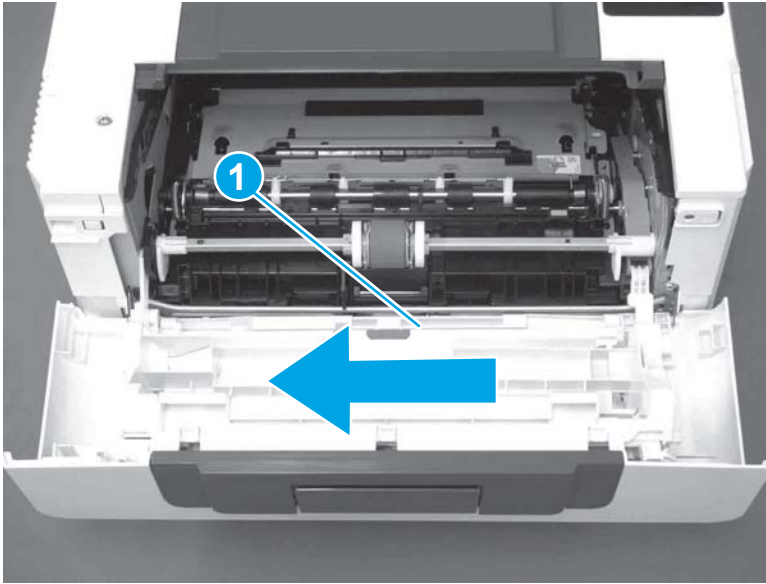

5. Remove the link (callout 1) from the cartridge door assembly (callout 2).

Figure 1-128 Release the left-side retainer arm

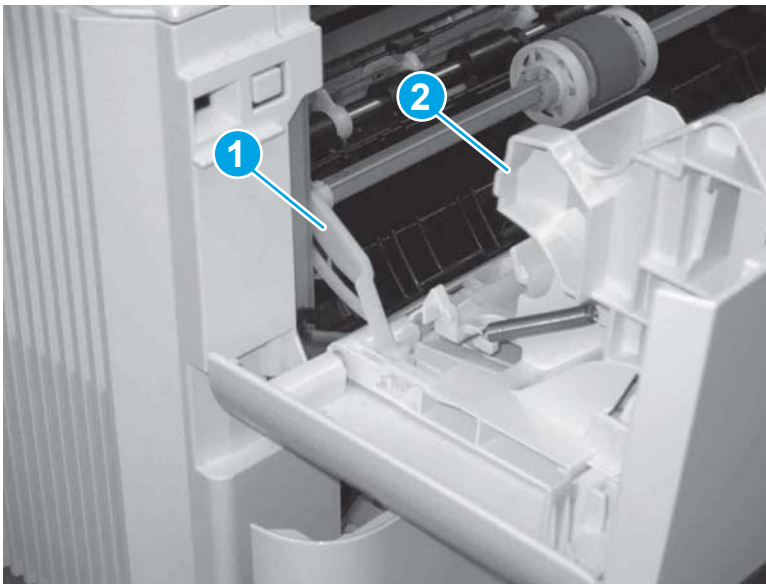

Step 3: Remove the right cover

1. Remove one screw (callout 1).

Figure 1-129 Remove one screw



2. At the front of the printer, release two bosses (callout 1), and then release three tabs (callout 2).

Figure 1-130 Release two bosses and three tabs

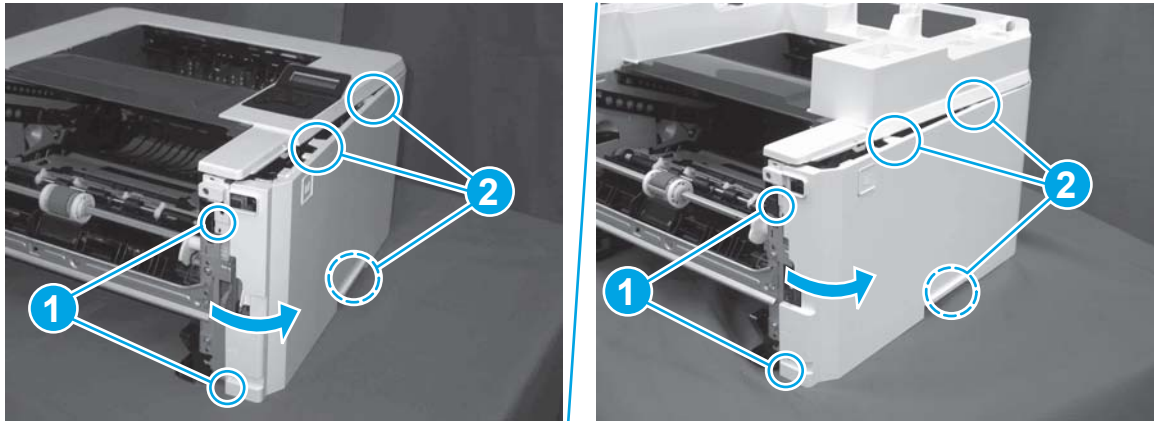

3. Open the rear door, release two bosses (callout 1), and then remove the cover (callout 2).

Figure 1-131 Remove the cover

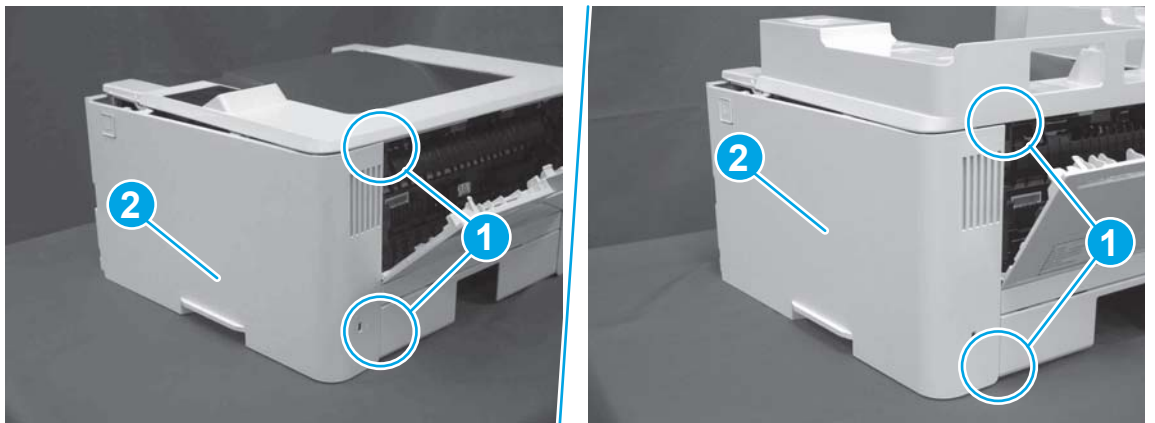

Step 4: Unpack the replacement assembly

Unpack the replacement part from the packaging.

<http://www8.hp.com/us/en/hp-information/environment/product-recycling.html>

 **NOTE:** HP recommends responsible disposal of the defective part.

Figure 1-132 Recycle and unpack

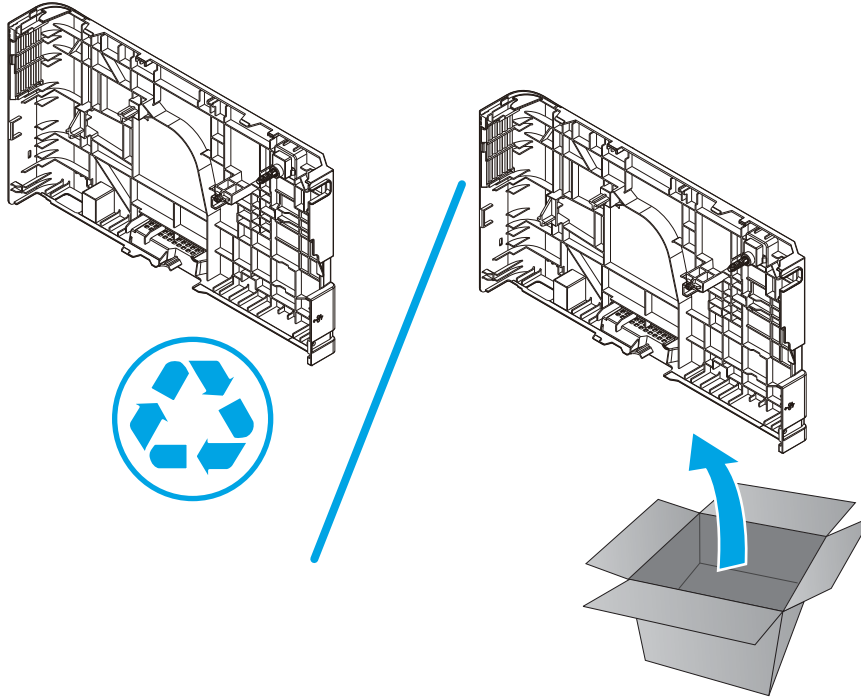

Step 5: Install the right cover

1. Position the cover (callout 1) on the printer, and then engage two bosses (callout 2).

Figure 1-133 Install the cover

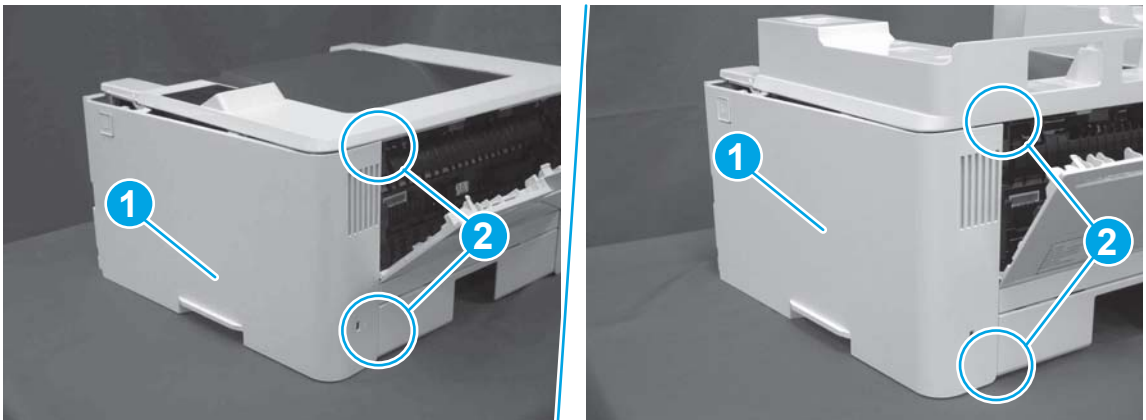

2. Rotate the front of the cover onto the printer (callout 1), engage three (callout 2) tabs, and then engage two bosses (callout 3).

Figure 1-134 Engage two bosses and one tab

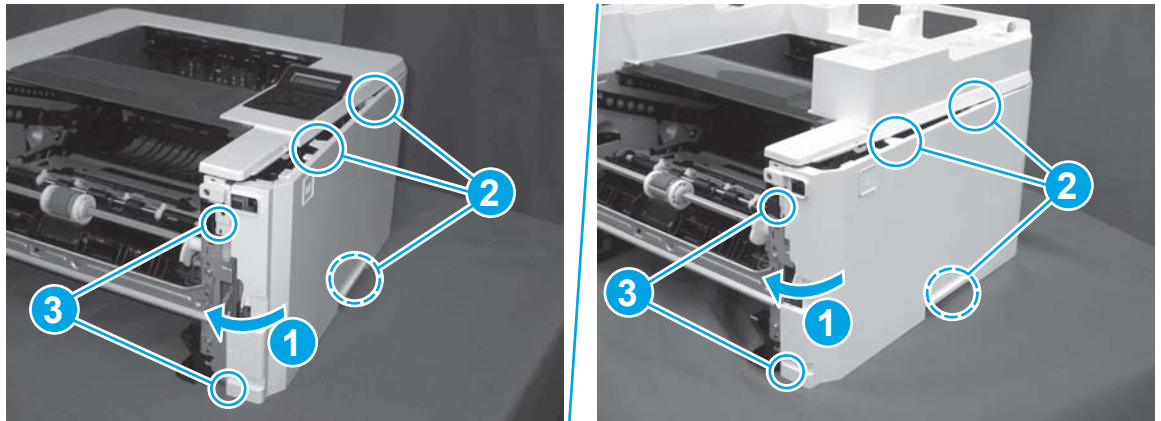

3. Make sure that the power switch (callout 1) and cartridge door assembly button (callout 2) correctly function.



NOTE: Remove, and then reinstall the cover if the switch or button does not correctly function.

Figure 1-135 Check the power switch and cartridge door assembly button

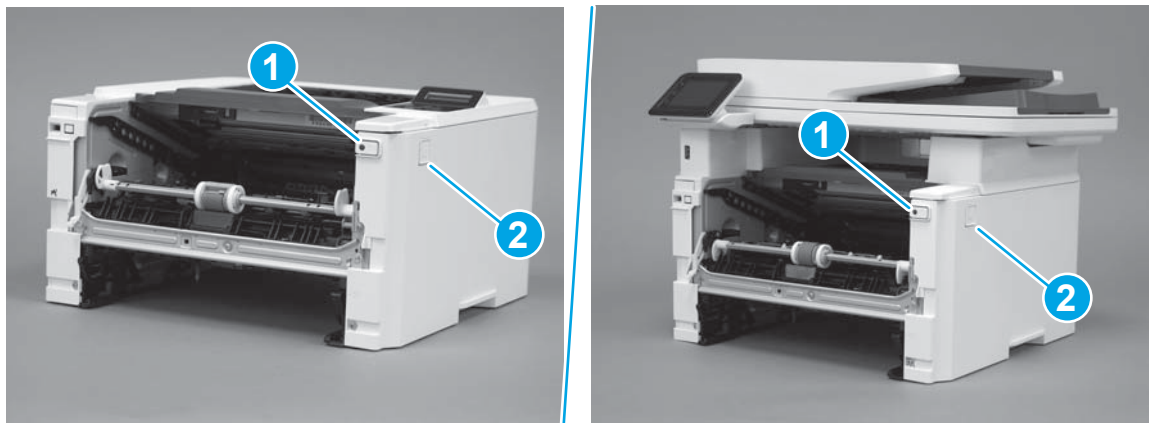

4. Install one screw (callout 1).

Figure 1-136 Install one screw



Step 6: Install the cartridge door assembly

 **Reinstallation tip:** After a replacement door is installed, make sure to install the nameplate (supplied in the kit) corresponding to the printer name on the door.

1. Position the door close to the printer, and then engage the keyed pin on the left-side retainer arm with the hole in the door.

Figure 1-137 Engage the left-side retainer arm

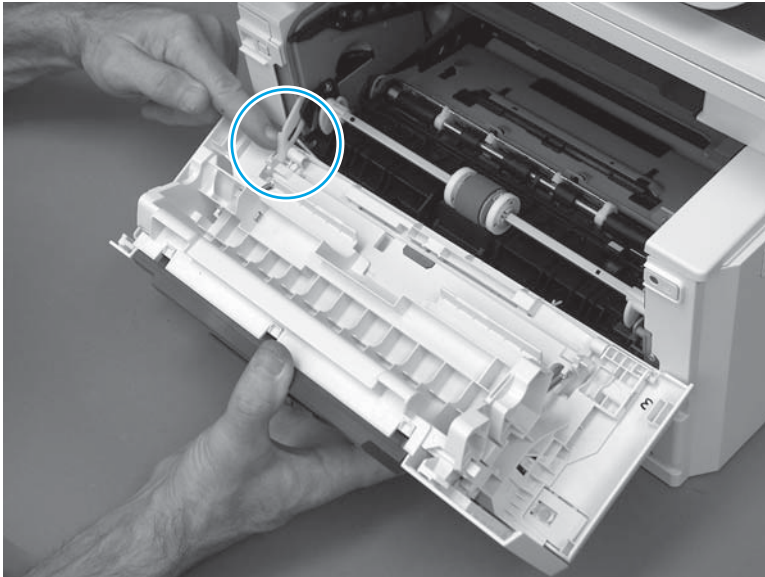

2. Engage the right-side door hinge pin with the hole in the chassis (callout 1).

Figure 1-138 Install the door

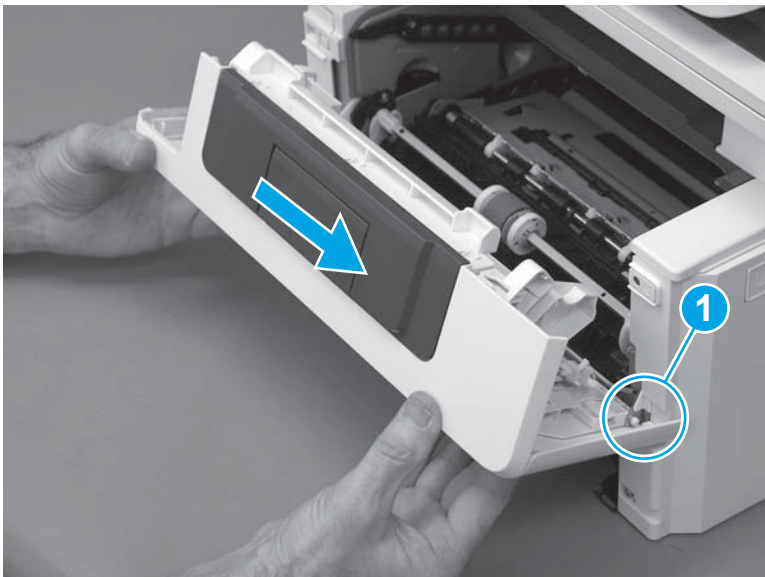

3. Install the link (callout 1).

 **IMPORTANT:** Make sure that the link snaps into place on the arm (callout 2). The link actuates the fuser pressure-release mechanism.

Figure 1-139 Install the pressure-release link

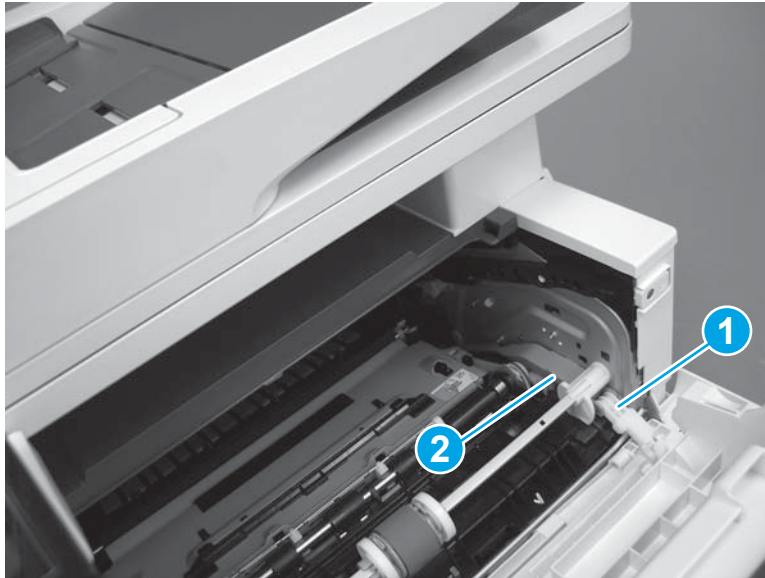

4. Slide the guide into the printer (callout 1), and then make sure that the tab (callout 2) snaps into place to secure the guide to the chassis.

Figure 1-140 Install the guide

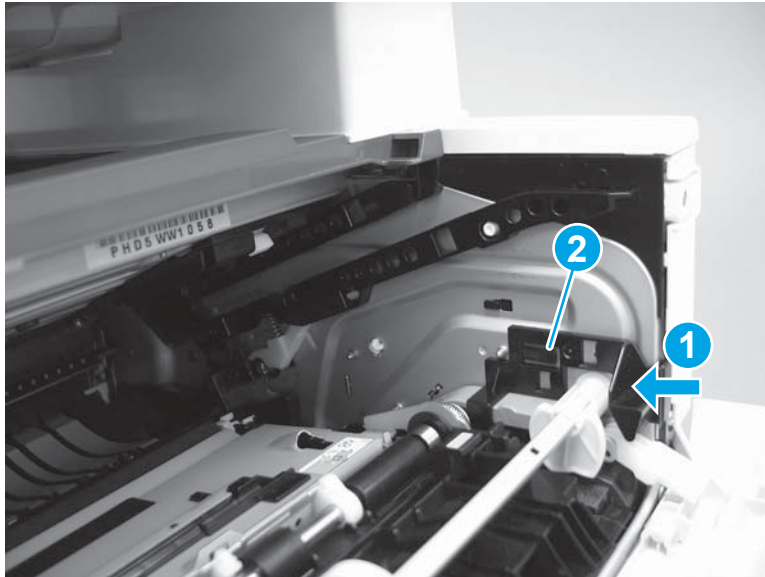

5. Position the shaft on the door, and then align the left-side hinge on the door with the hole in the chassis (callout 1).

Figure 1-141 Align the hinge

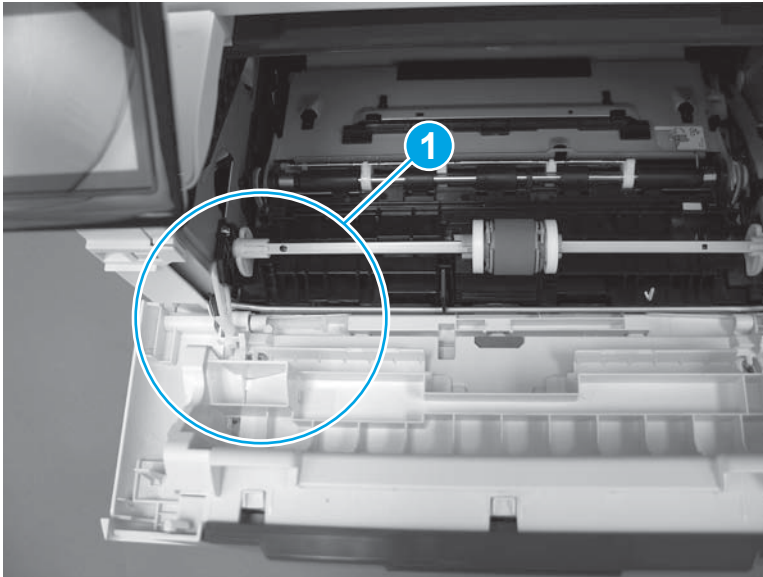

6. Push the shaft towards the left side of the printer to install it (callout 1).

 **Reinstallation tip:** Make sure that the support shaft is fully installed and correctly orientated (callout 2) so that it will not interfere with the door opening and closing.

Figure 1-142 Install the support shaft



Step 7: Install Tray 2

- ▲ Slide the tray straight into the printer to install it.

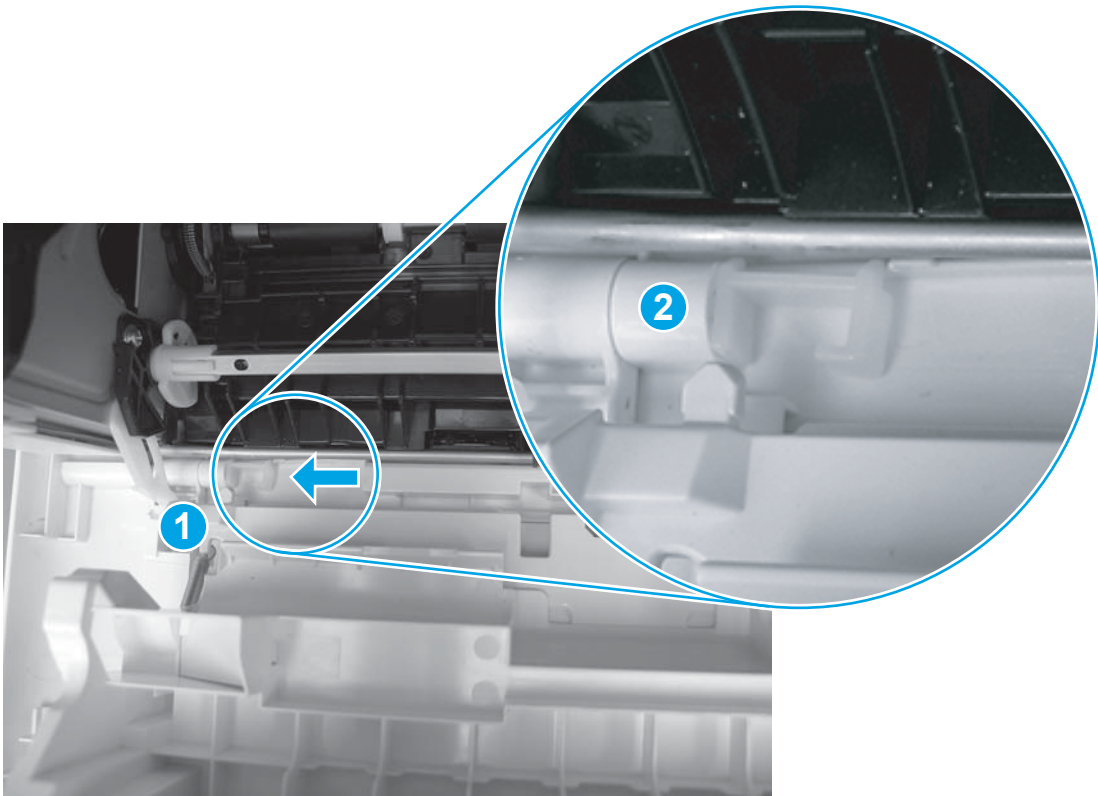
Figure 1-143 Install the tray



Removal and replacement: Rear door assembly



NOTE: Only duplex models have a duplex tray assembly installed.

- [Introduction](#)
- [Step 1: Remove Tray 2](#)
- [Step 2: Remove the cartridge door assembly](#)
- [Step 3: Remove the left cover](#)
- [Step 4: Remove the right cover](#)
- [Step 5: Remove the rear door assembly](#)
- [Step 6: Unpack the replacement assembly](#)
- [Step 7: Install the rear door assembly](#)
- [Step 8: Install the right cover](#)
- [Step 9: Install the left cover](#)
- [Step 10: Install the cartridge door assembly](#)
- [Step 11: Install Tray 2](#)

Introduction

This document provides the procedures to remove and replace the rear door assembly.

Before performing service

Turn the printer power off

- Disconnect the power cable.



WARNING! To avoid damage to the printer, turn the printer off, wait 30 seconds, and then remove the power cable before attempting to service the printer.

Use the table below to identify the correct part number for your printer. To order the part, go to www.hp.com/buy/parts.

Rear door assembly part number	
RM2-5430-000CN	Rear door assembly (simplex)
RM2-5405-000CN	Rear door assembly (duplex)

Required tools

- #2 Phillips screwdriver with a magnetic tip.

After performing service

Turn the printer power on

- Connect the power cable.
- Use the power switch to turn the power on.

Post service test

Make sure that the printer initializes to a **Ready** state.

Print a configuration page to make sure that the printer is functioning correctly.

Step 1: Remove Tray 2

- ▲ Pull the tray straight out of the printer to remove it.

Figure 1-144 Remove the tray



Step 2: Remove the cartridge door assembly



NOTE: If the toner cartridge was not removed prior to servicing the printer, remove it now.

1. Release one tab (callout 1), and then slide shaft (callout 2) in the direction the arrow indicates and remove it.



TIP: It might be easier to release the support shaft by using a small flat-blade screwdriver.

Figure 1-145 Release the support shaft

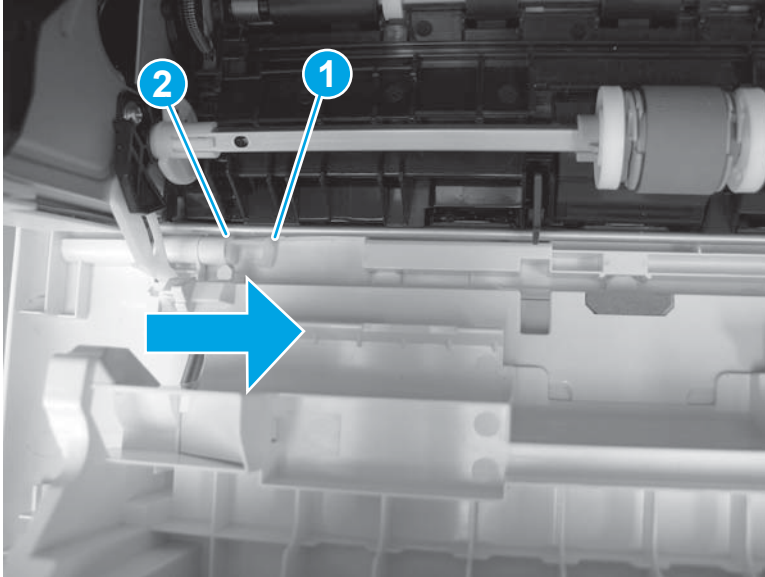

2. Release one tab (callout 1), and then slide the guide (callout 2) in the direction the arrow indicates and remove it.

Figure 1-146 Remove the guide

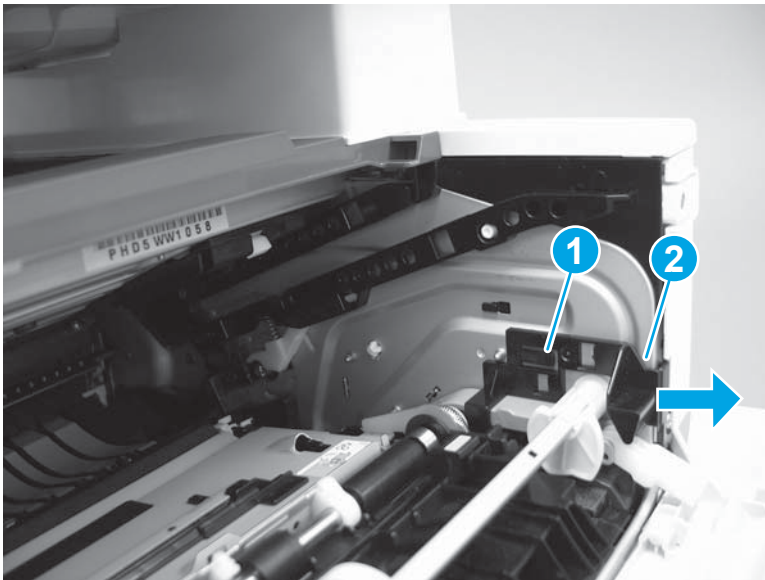

3. Remove the link arm (callout 1).

Figure 1-147 Remove the link arm

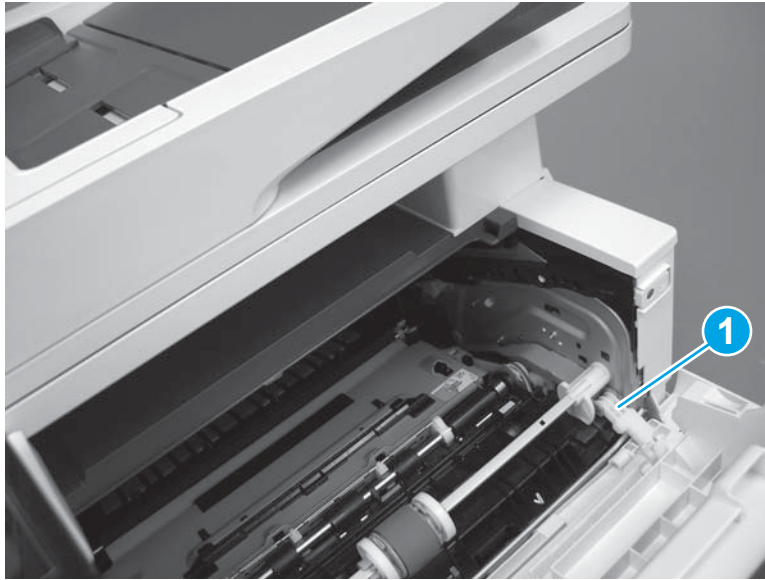

4. Slide the cartridge door assembly (callout 1) in the direction the arrow indicates and remove it.

Figure 1-148 Remove the door

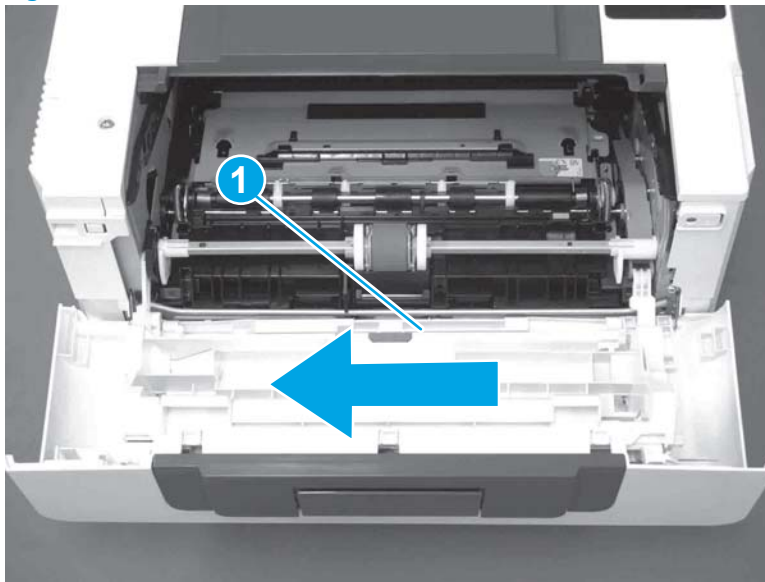

5. Remove the link (callout 1) from the cartridge door assembly (callout 2).

Figure 1-149 Release the left-side retainer arm

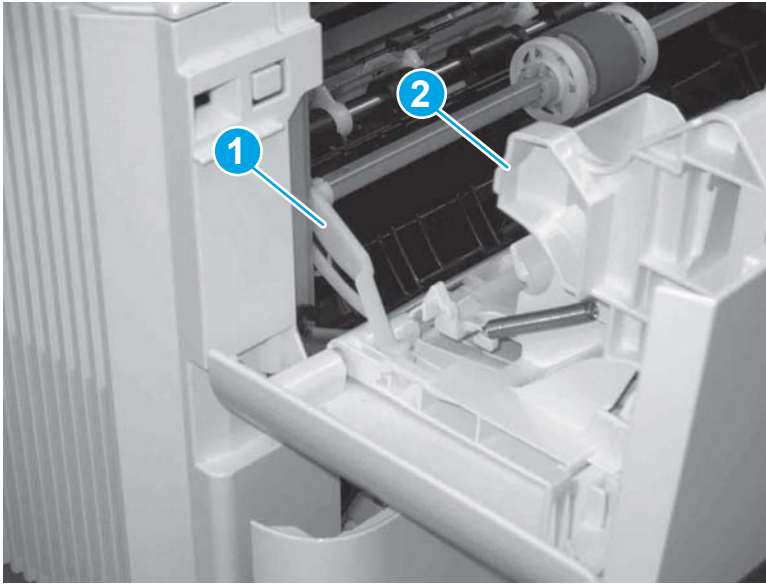

Step 3: Remove the left cover

1. Remove one screw (callout 1).

Figure 1-150 Remove one screw

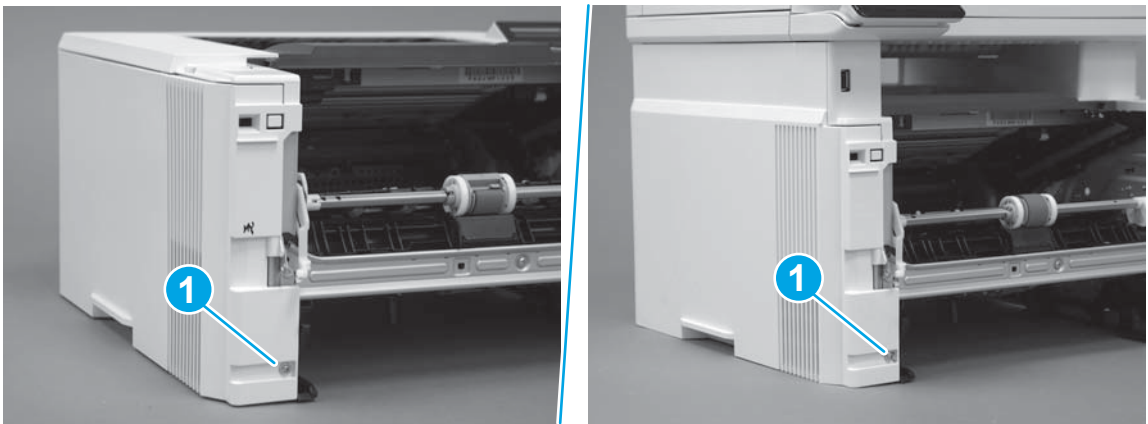

2. Open the rear door, release two bosses (callout 1), and then release three tabs (callout 2).

Figure 1-151 Release two bosses and three tabs

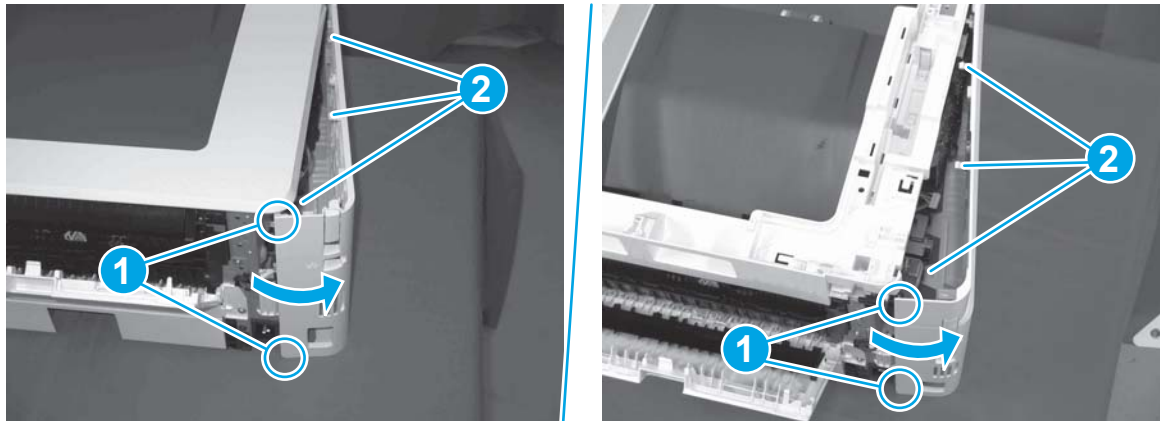

3. At the front of the printer, do one of the following:
 - **M403/M402:** Release two bosses (callout 1), and then remove the cover (callout 2).
 - **M427/M426:** Release one tab (callout 3), two bosses (callout 4), and then remove the cover (callout 5).

CAUTION: Be careful when releasing the upper bosses on the M427/M426 cover. One portion of the cover (callout 6) is fragile and is easily broken.

Figure 1-152 Remove the cover

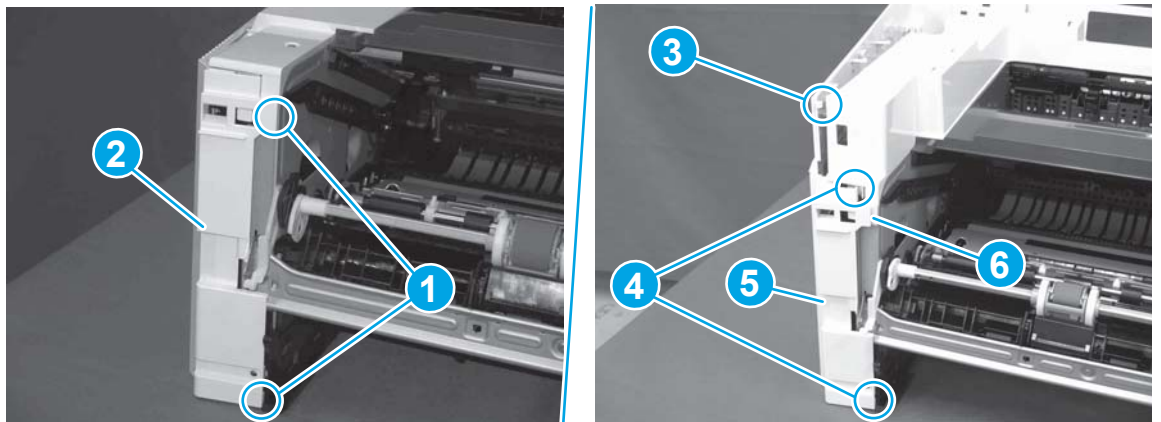

Step 4: Remove the right cover

1. Remove one screw (callout 1).

Figure 1-153 Remove one screw



2. At the front of the printer, release two bosses (callout 1), and then release three tabs (callout 2).

Figure 1-154 Release two bosses and three tabs

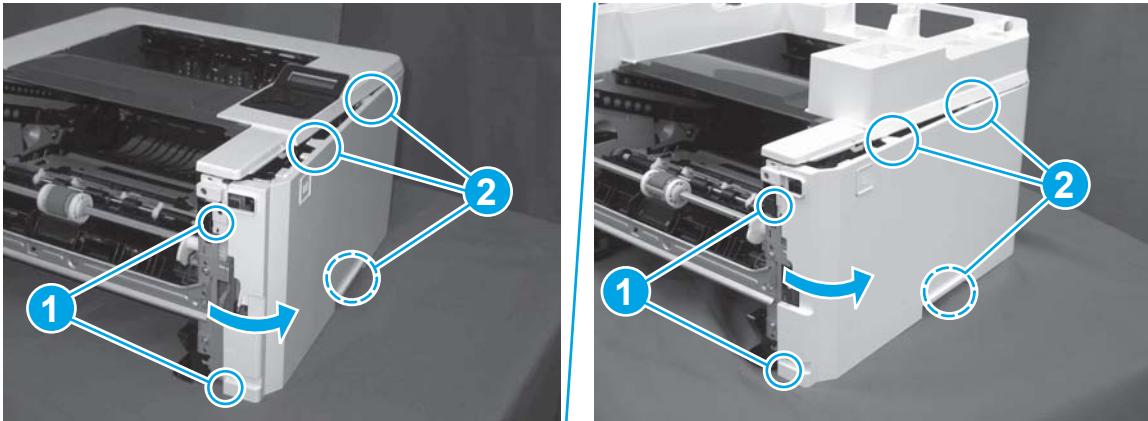

3. Open the rear door, release two bosses (callout 1), and then remove the cover (callout 2).

Figure 1-155 Remove the cover

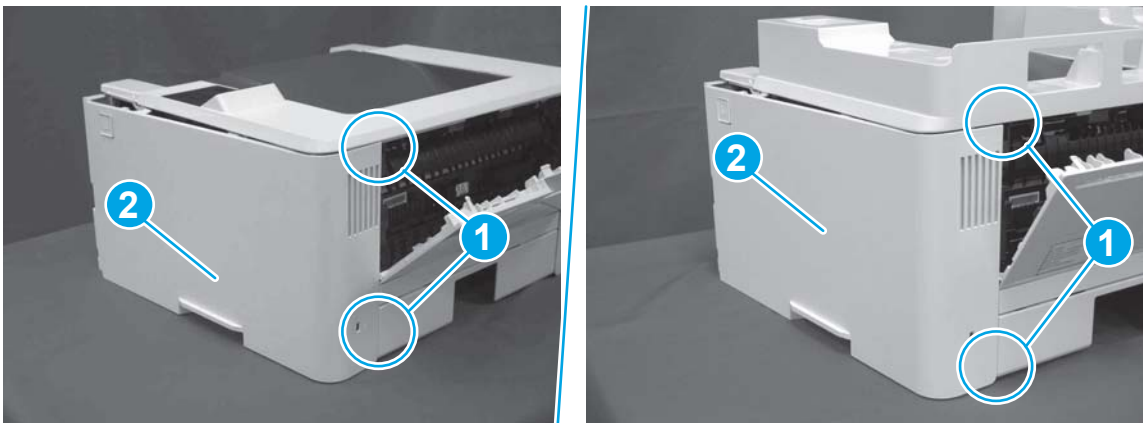

Step 5: Remove the rear door assembly

1. **Duplex models only:** Inside the Tray 2 cavity, press the green jam access lever (callout 1), and then lower the duplex feed assembly (callout 2).

Figure 1-156 Duplex models, lower the duplex feed assembly

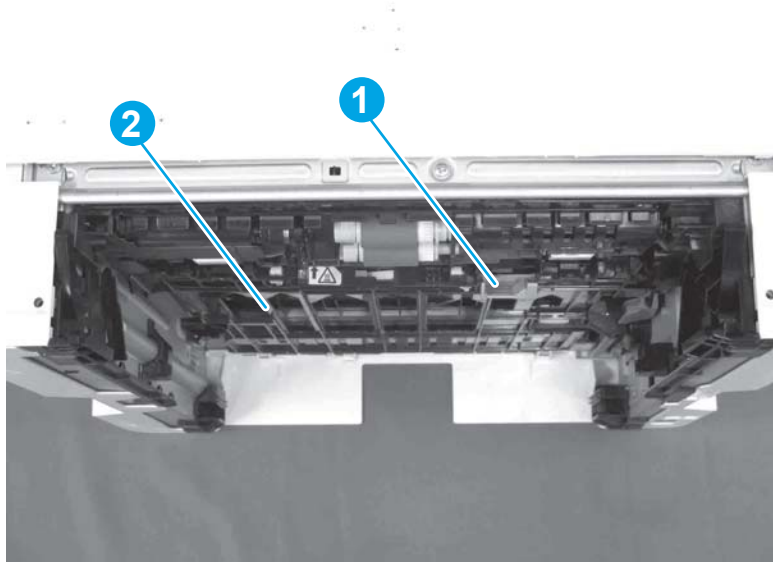

2. At the rear of the printer, remove two screws (callout 1), and then remove the rear door assembly (callout 2).

Figure 1-157 Remove two screws

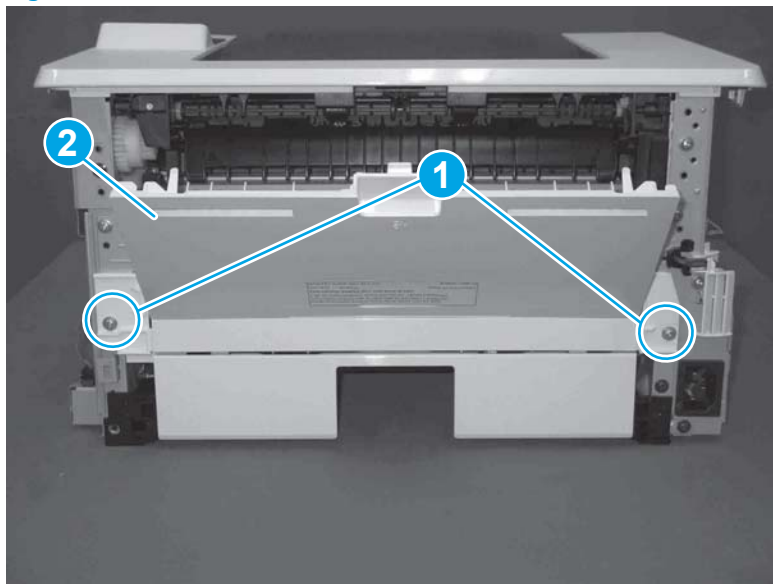

Step 6: Unpack the replacement assembly

Unpack the replacement part from the packaging.

<http://www8.hp.com/us/en/hp-information/environment/product-recycling.html>

 **NOTE:** HP recommends responsible disposal of the defective part.

Figure 1-158 Recycle and unpack

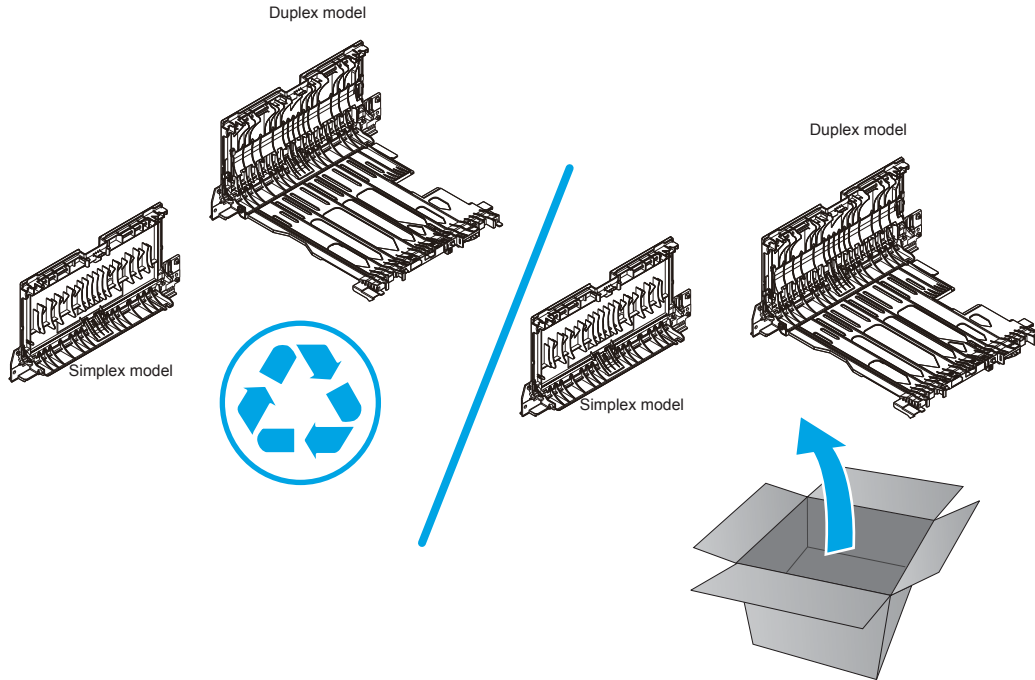

Step 7: Install the rear door assembly

1. At the rear of the printer, position the assembly so that the two tabs (callout 1) are installed in the slots (callout 2) in the chassis.

 **NOTE:** Duplex models only: Slide the duplex tray into the Tray 2 cavity.

Figure 1-159 Install the rear cover



2. Install two screws.

 **NOTE: Duplex models only:** Reach in from the front of the Tray 2 cavity and raise the feed assembly to the up and locked position so that the rear cover will fit flat against the chassis.

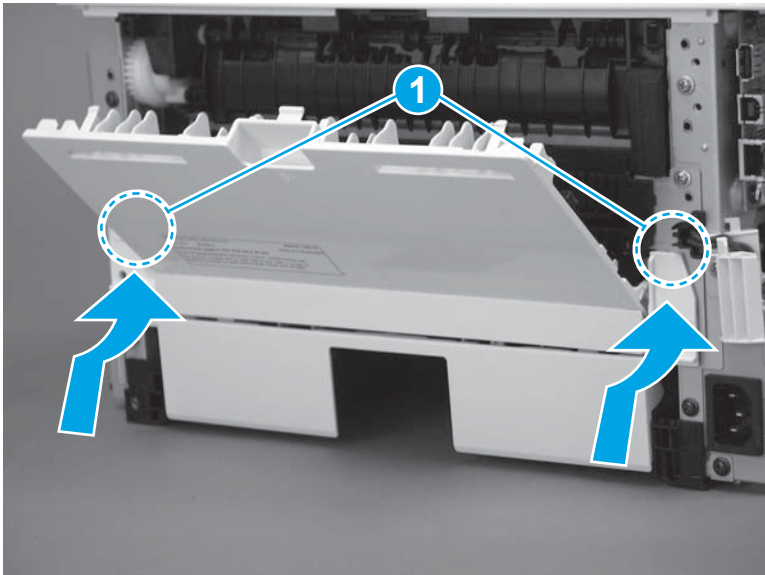
Figure 1-160 Install two screws



Step 8: Install the right cover

1. Position the cover (callout 1) on the printer, and then engage two bosses (callout 2).

Figure 1-161 Install the cover

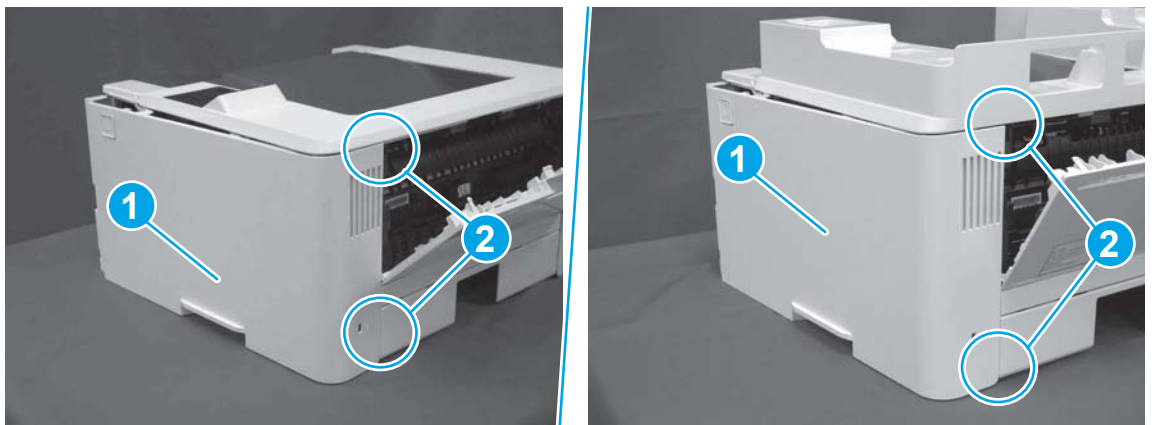

2. Rotate the front of the cover onto the printer (callout 1), engage three (callout 2) tabs, and then engage two bosses (callout 3).

Figure 1-162 Engage two bosses and one tab

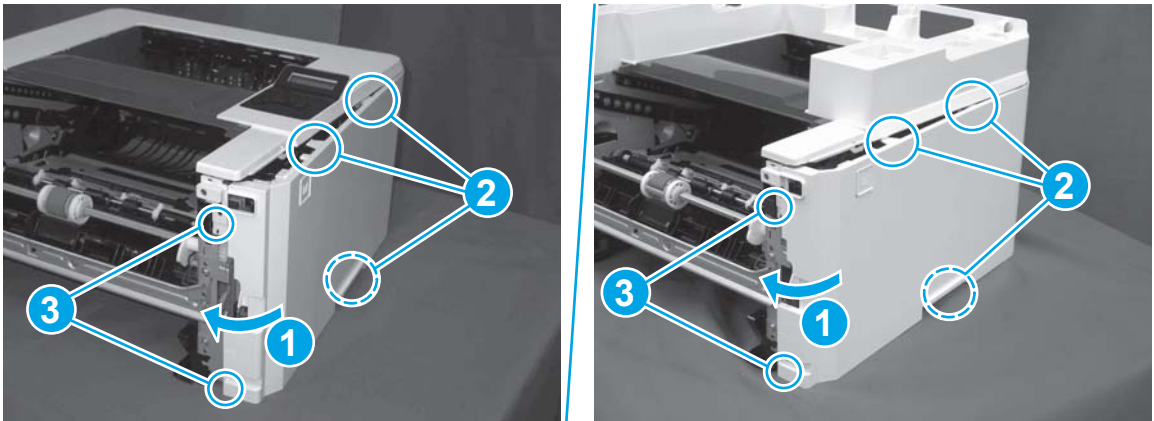

3. Make sure that the power switch (callout 1) and cartridge door assembly button (callout 2) correctly function.



NOTE: Remove, and then reinstall the cover if the switch or button does not correctly function.

Figure 1-163 Check the power switch and cartridge door assembly button

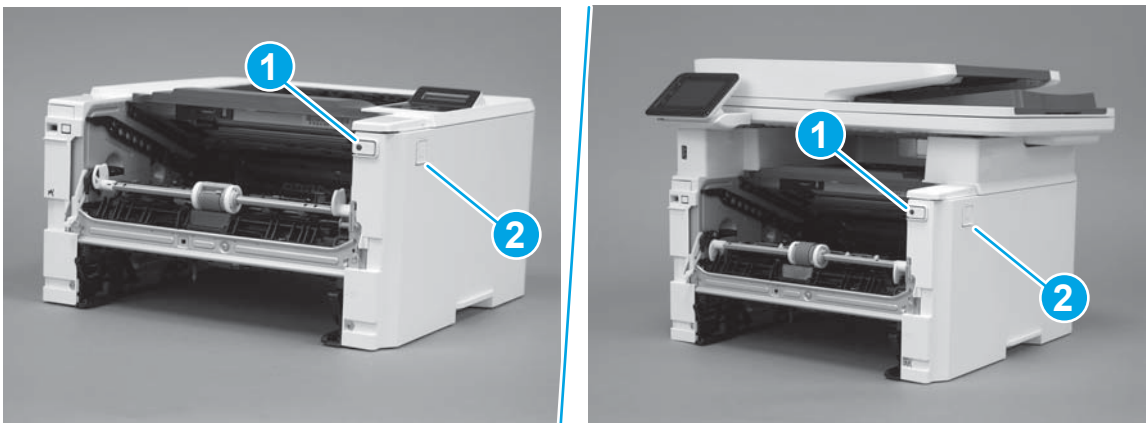

4. Install one screw (callout 1).

Figure 1-164 Install one screw



Step 9: Install the left cover

1. At the front of the printer, do one of the following:
 - **M403/M402:** Position the cover on the printer (callout 1), and then engage two bosses (callout 2).
 - **M427/M426:** Position the cover on the printer (callout 3), engage one tab (callout 4), and then engage two bosses (callout 4).

Figure 1-165 Install the cover

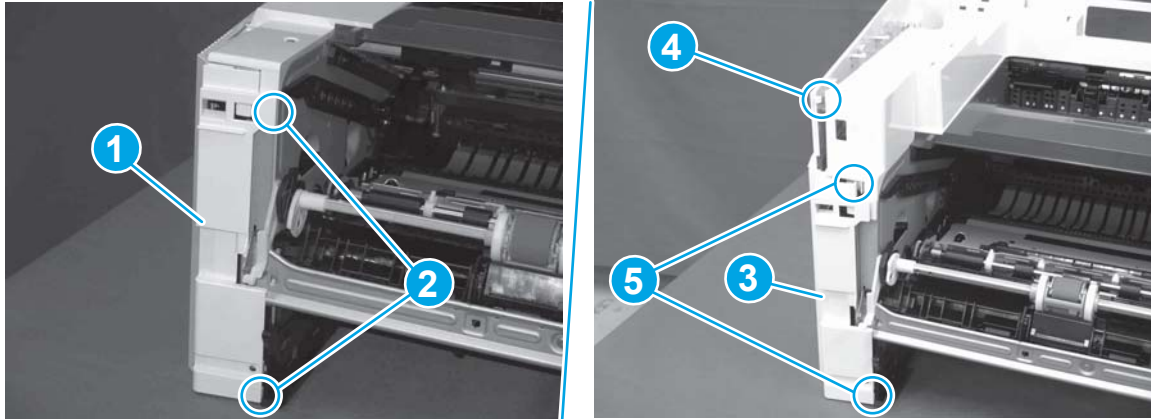

2. Carefully rotate the rear of the cover onto the printer (callout 1), engage three tabs (callout 2), and then engage two bosses (callout 3).

Figure 1-166 Engage three tabs and two bosses

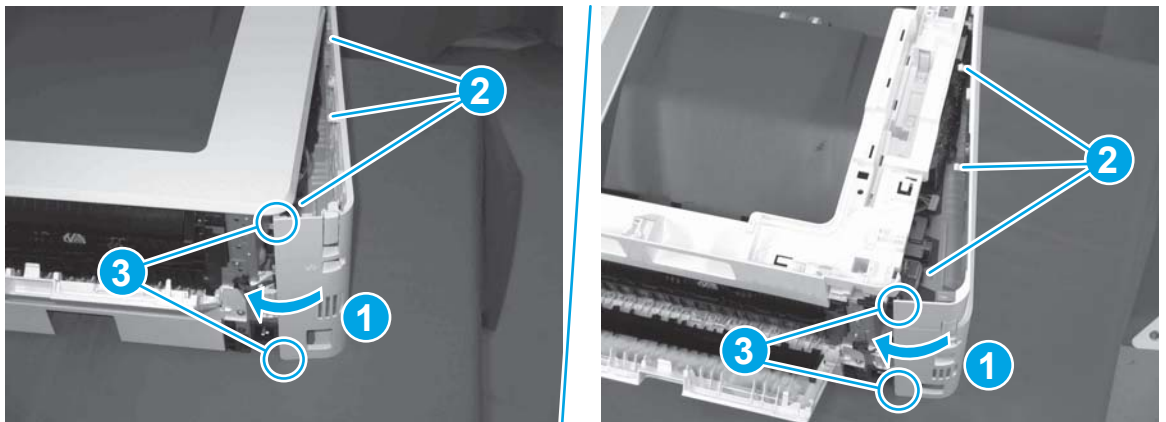

3. Install one screw (callout 1).

Figure 1-167 Install one screw

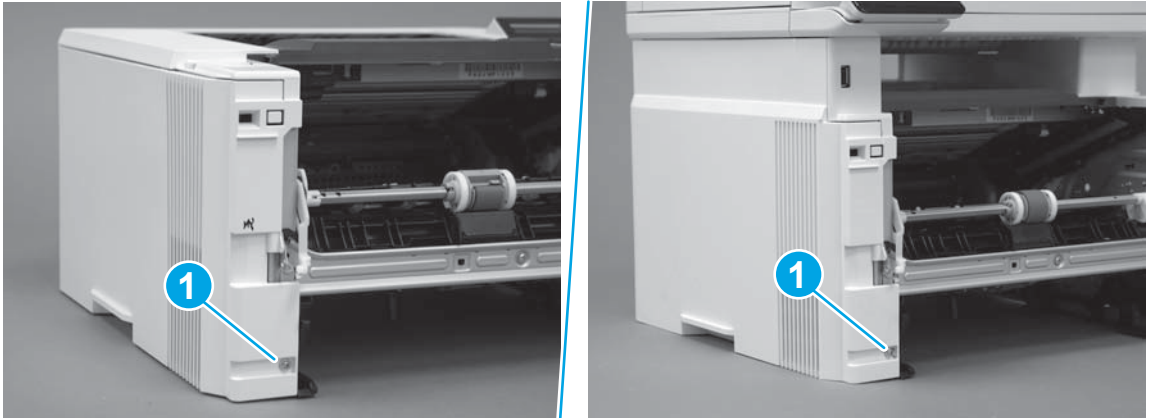

Step 10: Install the cartridge door assembly

 **Reinstallation tip:** After a replacement door is installed, make sure to install the nameplate (supplied in the kit) corresponding to the printer name on the door.

1. Position the door close to the printer, and then engage the keyed pin on the left-side retainer arm with the hole in the door.

Figure 1-168 Engage the left-side retainer arm

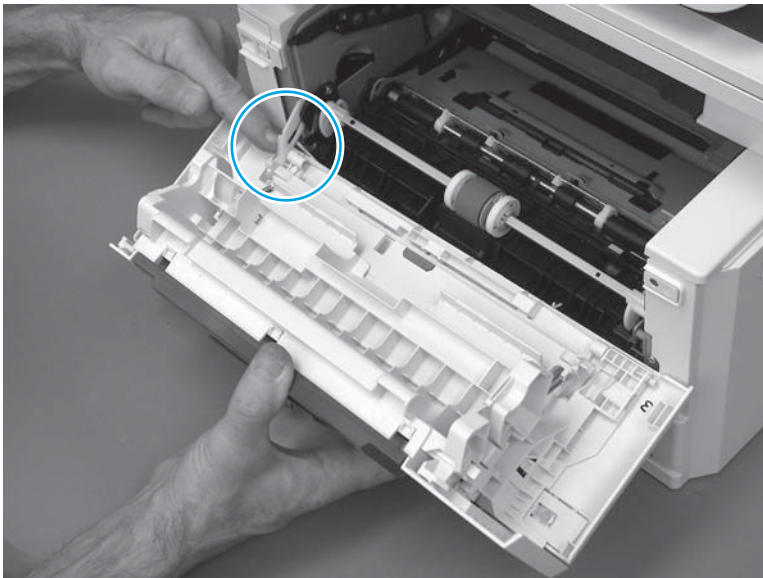

2. Engage the right-side door hinge pin with the hole in the chassis (callout 1).

Figure 1-169 Install the door

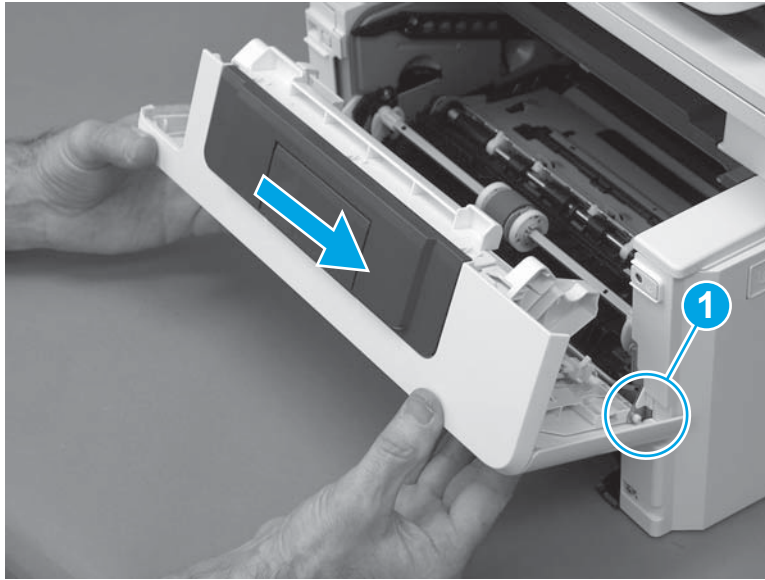

3. Install the link (callout 1).

 **IMPORTANT:** Make sure that the link snaps into place on the arm (callout 2). The link actuates the fuser pressure-release mechanism.

Figure 1-170 Install the pressure-release link

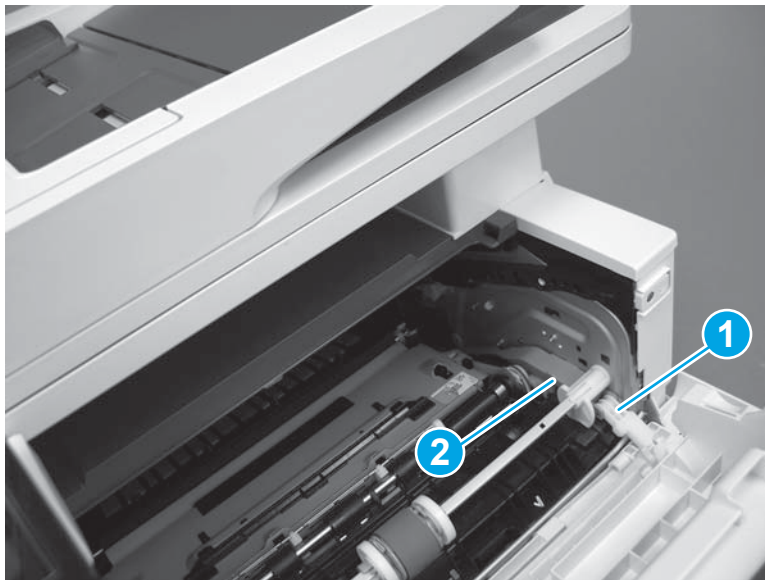

4. Slide the guide into the printer (callout 1), and then make sure that the tab (callout 2) snaps into place to secure the guide to the chassis.

Figure 1-171 Install the guide

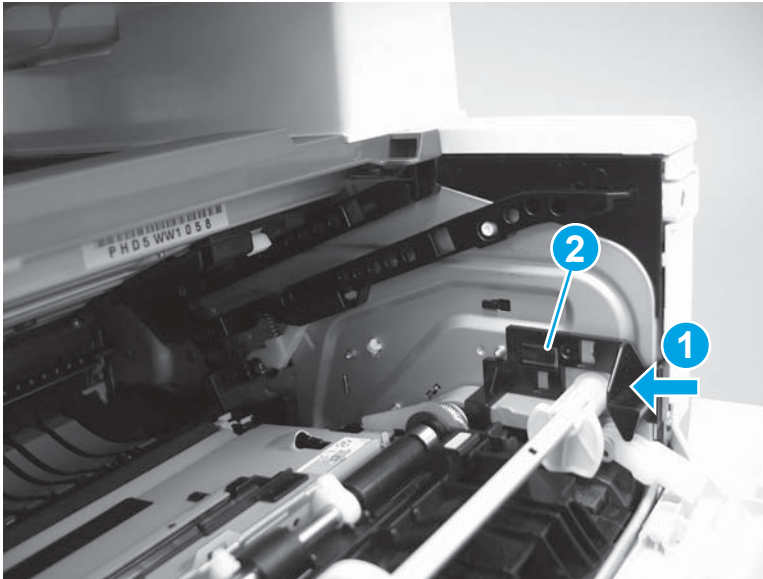

5. Position the shaft on the door, and then align the left-side hinge on the door with the hole in the chassis (callout 1).

Figure 1-172 Align the hinge

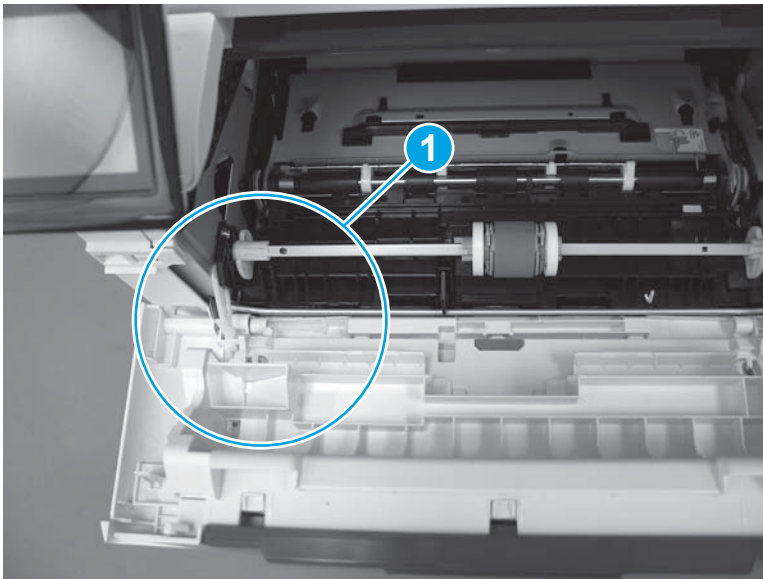

6. Push the shaft towards the left side of the printer to install it (callout 1).

 **Reinstallation tip:** Make sure that the support shaft is fully installed and correctly orientated (callout 2) so that it will not interfere with the door opening and closing.

Figure 1-173 Install the support shaft



Step 11: Install Tray 2

- ▲ Slide the tray straight into the printer to install it.

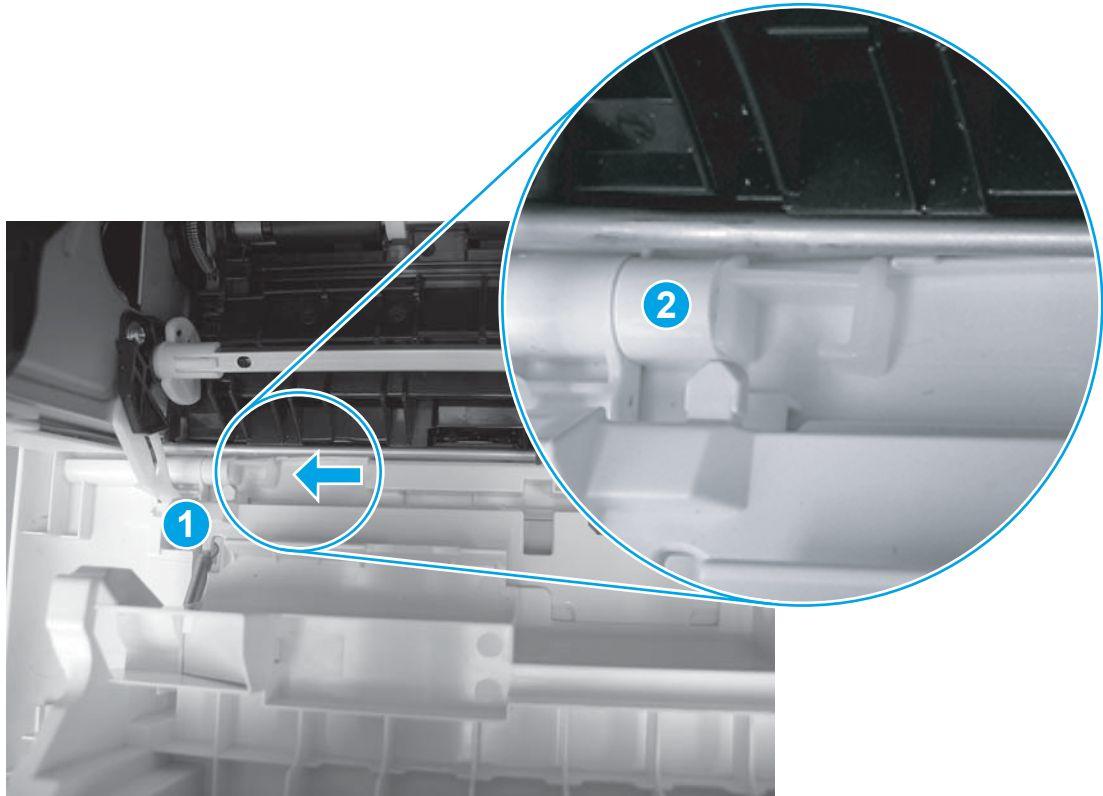
Figure 1-174 Install the tray



Removal and replacement: Cassette rear cover

- [Introduction](#)
- [Step 1: Remove Tray 2](#)
- [Step 2: Remove the cartridge door assembly](#)
- [Step 3: Remove the left cover](#)
- [Step 4: Remove the right cover](#)
- [Step 5: Remove the rear door assembly](#)
- [Step 6: Remove the cassette rear cover](#)
- [Step 7: Unpack the replacement assembly](#)
- [Step 8: Install the cassette rear door assembly](#)
- [Step 9: Install the rear door assembly](#)
- [Step 10: Install the right cover](#)
- [Step 11: Install the left cover](#)
- [Step 12: Install the cartridge door assembly](#)
- [Step 13: Install Tray 2](#)

Introduction

This document provides the procedures to remove and replace the cassette rear cover.

Before performing service

Turn the printer power off

- Disconnect the power cable.

 **WARNING!** To avoid damage to the printer, turn the printer off, wait 30 seconds, and then remove the power cable before attempting to service the printer.

Use the table below to identify the correct part number for your printer. To order the part, go to www.hp.com/buy/parts.

Cassette rear cover part number

RC4-3082-000CNCassette rear cover

Required tools

- #2 Phillips screwdriver with a magnetic tip.

After performing service

Turn the printer power on

- Connect the power cable.
- Use the power switch to turn the power on.

Post service test

Make sure that the printer initializes to a **Ready** state.

Print a configuration page to make sure that the printer is functioning correctly.

Step 1: Remove Tray 2

- ▲ Pull the tray straight out of the printer to remove it.

Figure 1-175 Remove the tray



Step 2: Remove the cartridge door assembly



NOTE: If the toner cartridge was not removed prior to servicing the printer, remove it now.

1. Release one tab (callout 1), and then slide shaft (callout 2) in the direction the arrow indicates and remove it.



TIP: It might be easier to release the support shaft by using a small flat-blade screwdriver.

Figure 1-176 Release the support shaft

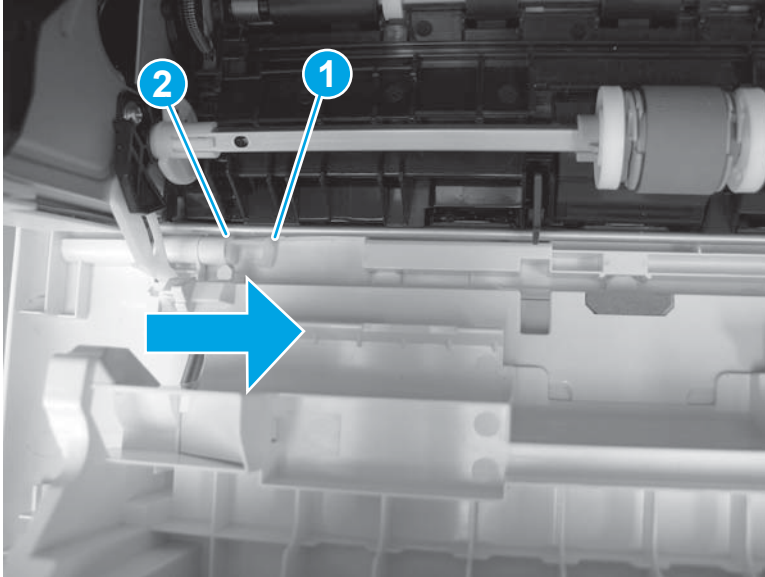

2. Release one tab (callout 1), and then slide the guide (callout 2) in the direction the arrow indicates and remove it.

Figure 1-177 Remove the guide

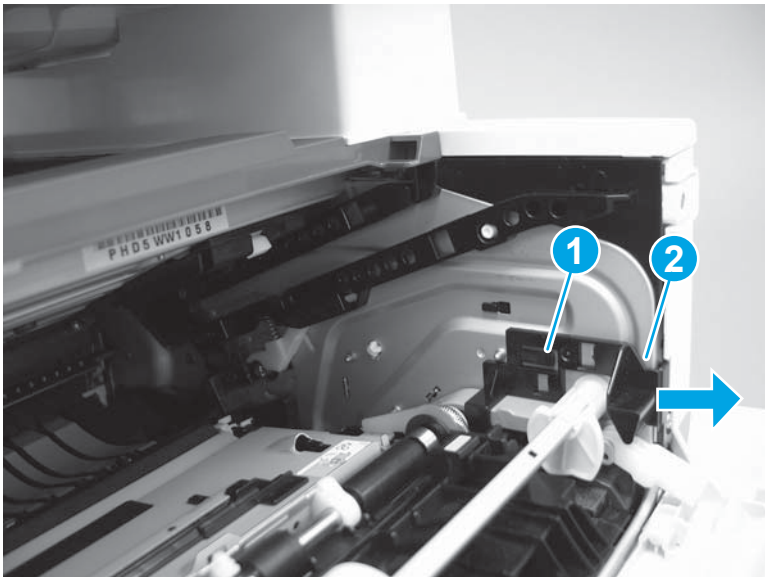

3. Remove the link arm (callout 1).

Figure 1-178 Remove the link arm

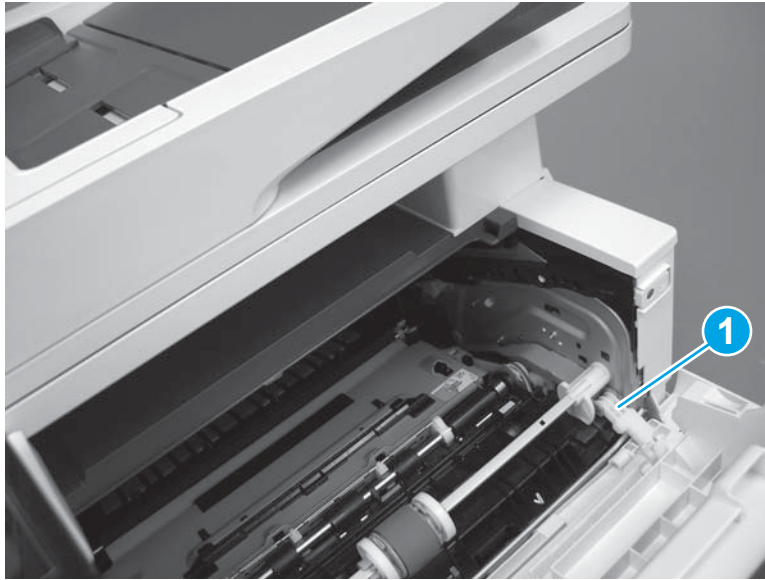

4. Slide the cartridge door assembly (callout 1) in the direction the arrow indicates and remove it.

Figure 1-179 Remove the door

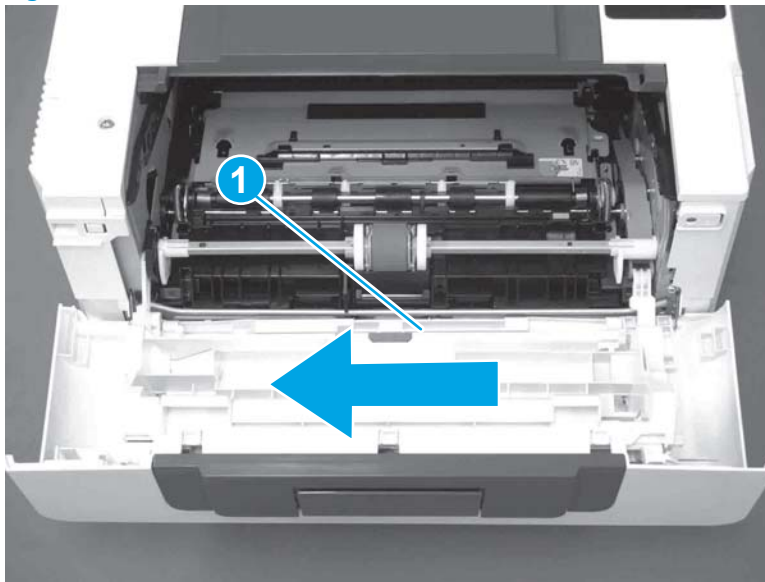

5. Remove the link (callout 1) from the cartridge door assembly (callout 2).

Figure 1-180 Release the left-side retainer arm

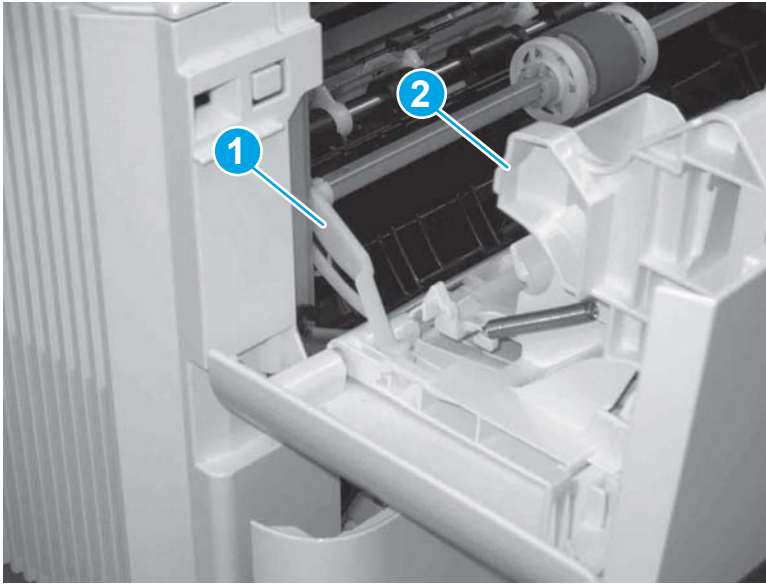

Step 3: Remove the left cover

1. Remove one screw (callout 1).

Figure 1-181 Remove one screw

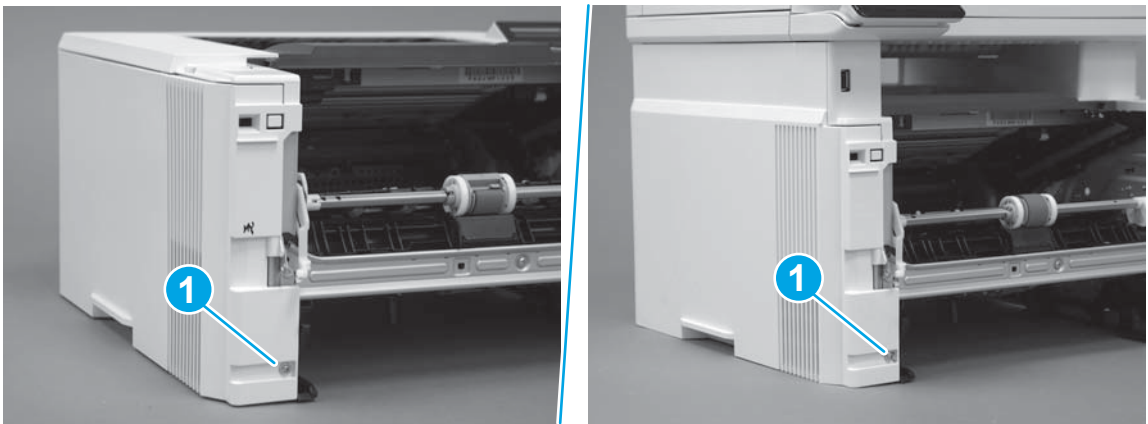

2. Open the rear door, release two bosses (callout 1), and then release three tabs (callout 2).

Figure 1-182 Release two bosses and three tabs

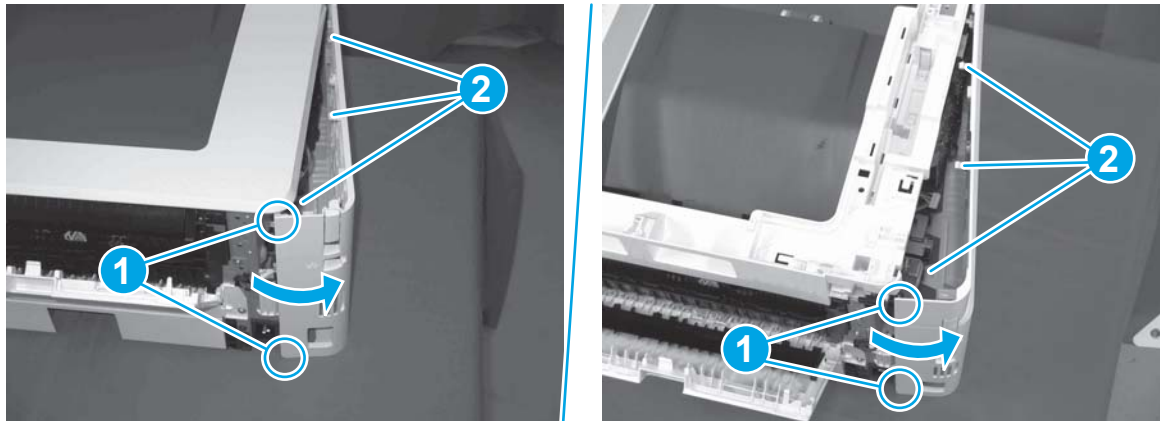

3. At the front of the printer, do one of the following:

- **M403/M402:** Release two bosses (callout 1), and then remove the cover (callout 2).
- **M427/M426:** Release one tab (callout 3), two bosses (callout 4), and then remove the cover (callout 5).

CAUTION: Be careful when releasing the upper bosses on the M427/M426 cover. One portion of the cover (callout 6) is fragile and is easily broken.

Figure 1-183 Remove the cover

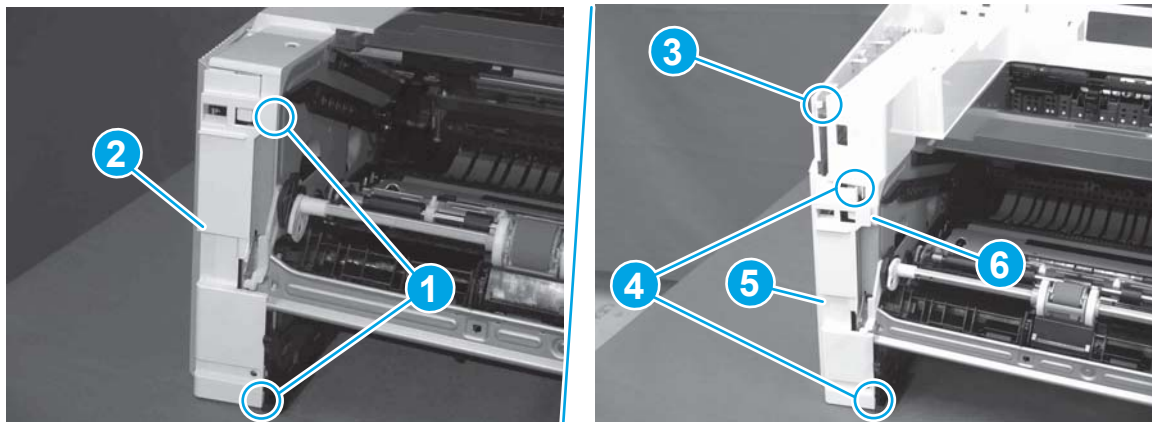

Step 4: Remove the right cover

1. Remove one screw (callout 1).

Figure 1-184 Remove one screw



2. At the front of the printer, release two bosses (callout 1), and then release three tabs (callout 2).

Figure 1-185 Release two bosses and three tabs

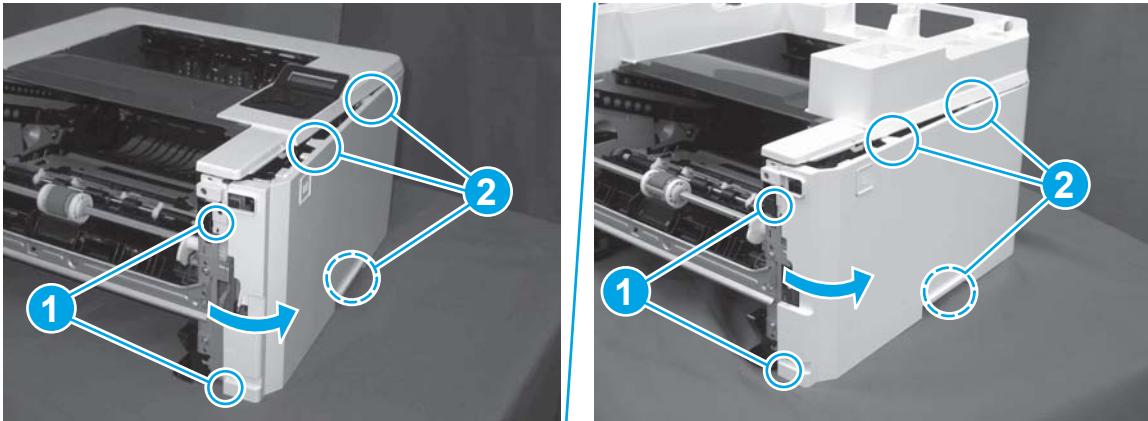

3. Open the rear door, release two bosses (callout 1), and then remove the cover (callout 2).

Figure 1-186 Remove the cover

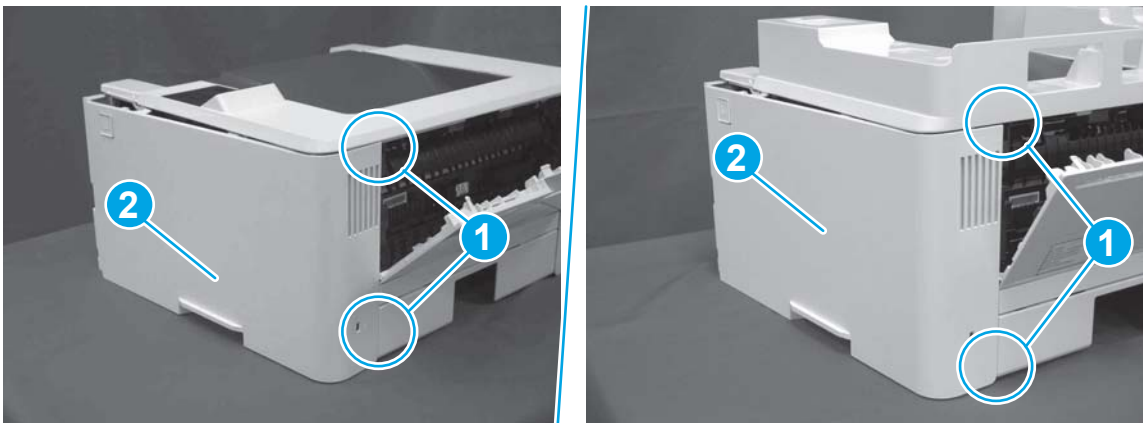

Step 5: Remove the rear door assembly

1. **Duplex models only:** Inside the Tray 2 cavity, press the green jam access lever (callout 1), and then lower the duplex feed assembly (callout 2).

Figure 1-187 Duplex models, lower the duplex feed assembly

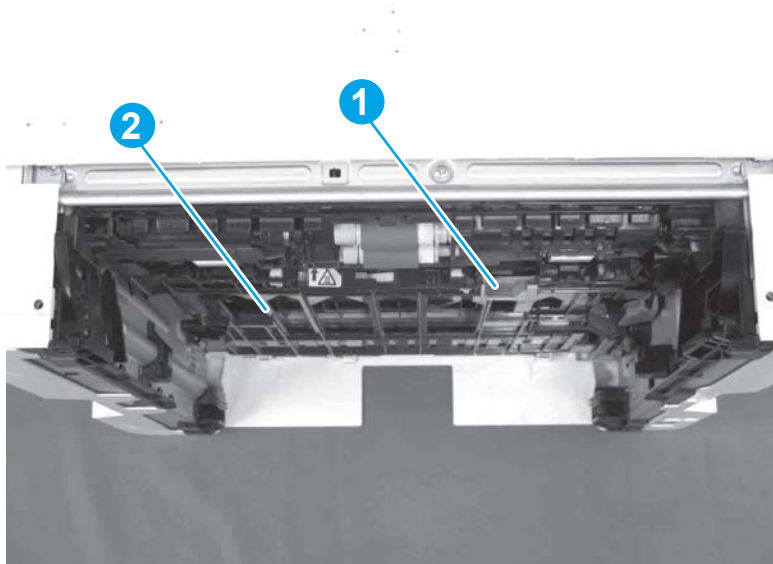

2. At the rear of the printer, remove two screws (callout 1), and then remove the rear door assembly (callout 2).

Figure 1-188 Remove two screws

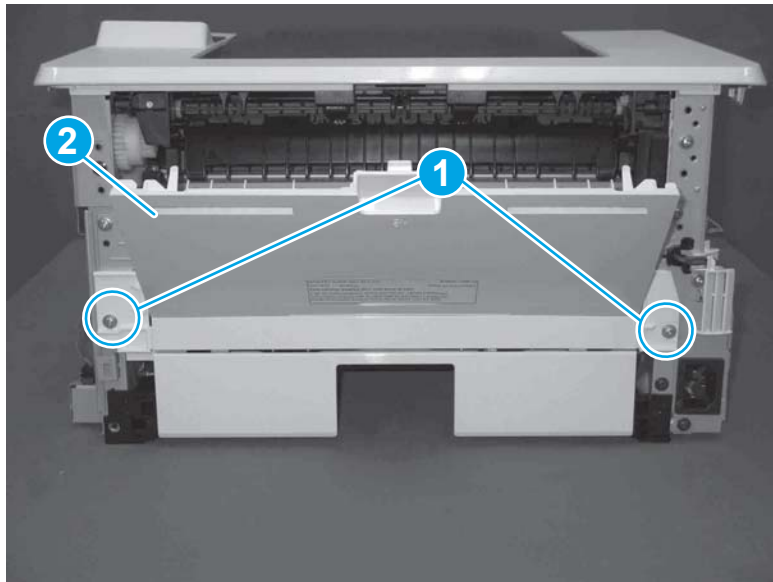

Step 6: Remove the cassette rear cover

The figures in this procedure show a duplex rear cover assembly. However, the procedure is valid for a simple rear cover.

1. Locate the left-side hinge retainer (callout 1).

Figure 1-189 Locate the hinge retainer

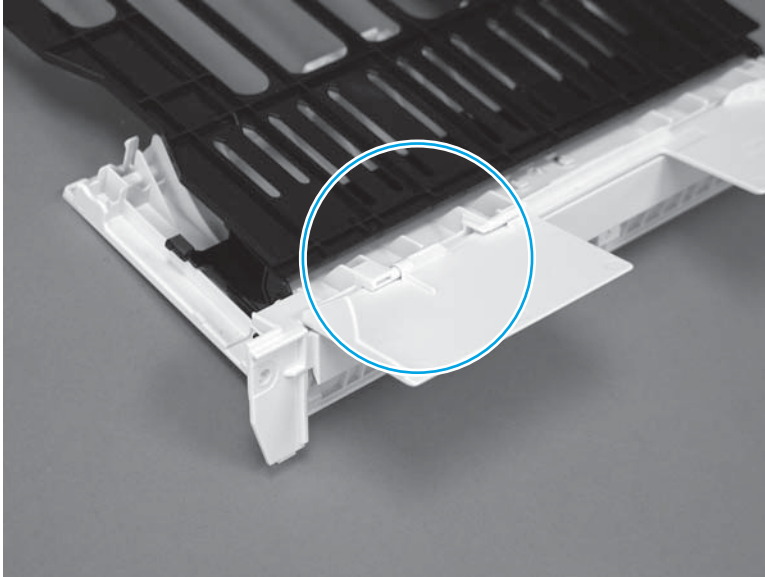

2. Carefully flex the cover to release the retainer (callout 1), and the left-side hinge pin (callout 2).

Figure 1-190 Release the retainer and the hinge pin

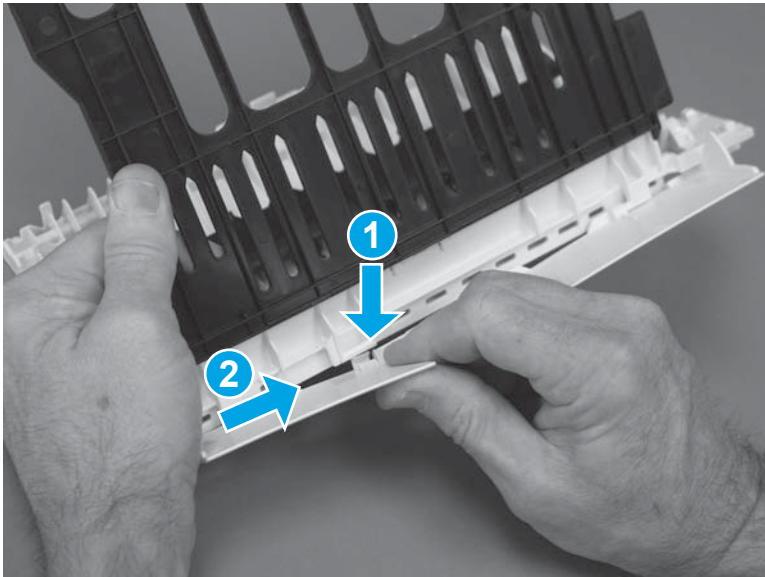

3. Remove the cover.

Figure 1-191 Remove the cover

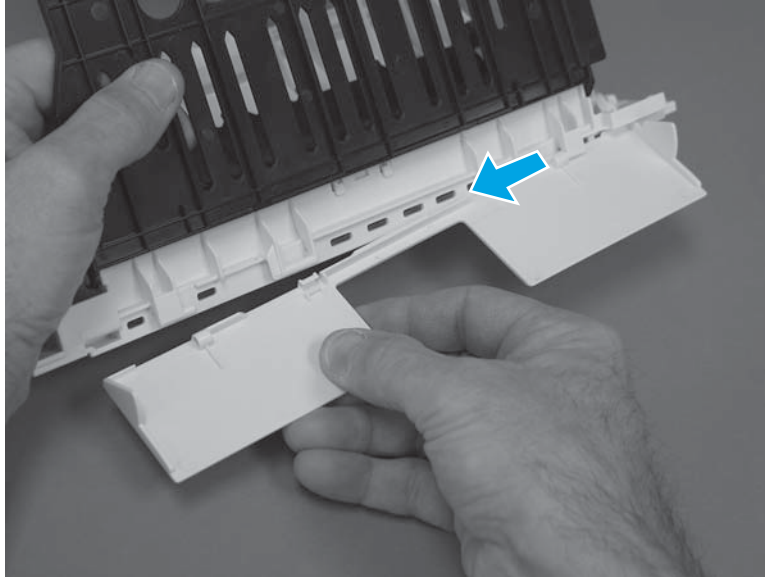

Step 7: Unpack the replacement assembly

Unpack the replacement part from the packaging.

<http://www8.hp.com/us/en/hp-information/environment/product-recycling.html>

 **NOTE:** HP recommends responsible disposal of the defective part.

Figure 1-192 Recycle and unpack

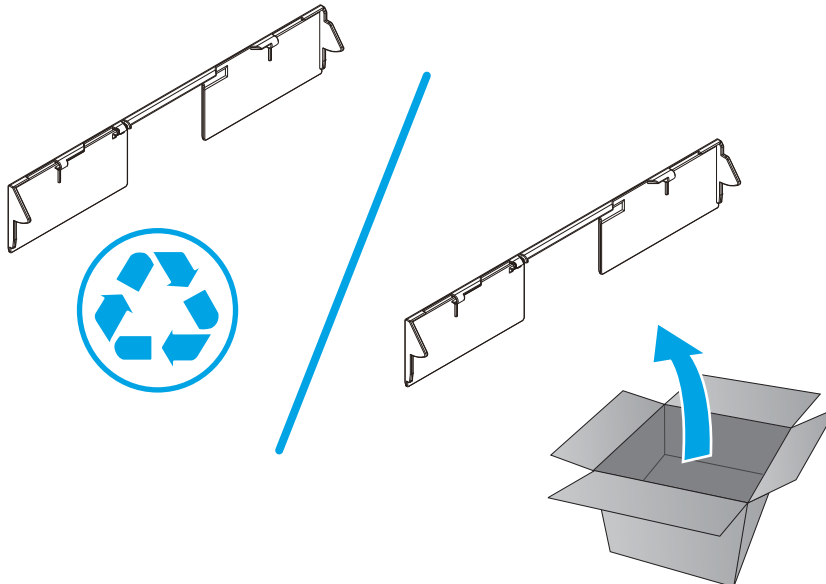

Step 8: Install the cassette rear door assembly

The figures in this procedure show a duplex rear cover assembly. However, the procedure is valid for a simple rear cover.

1. Position the cover on the rear door with the right-side hinge holder on the cover engaged with the right-side hinge pin on the door.

Figure 1-193 Engage the right-side hinge and pin

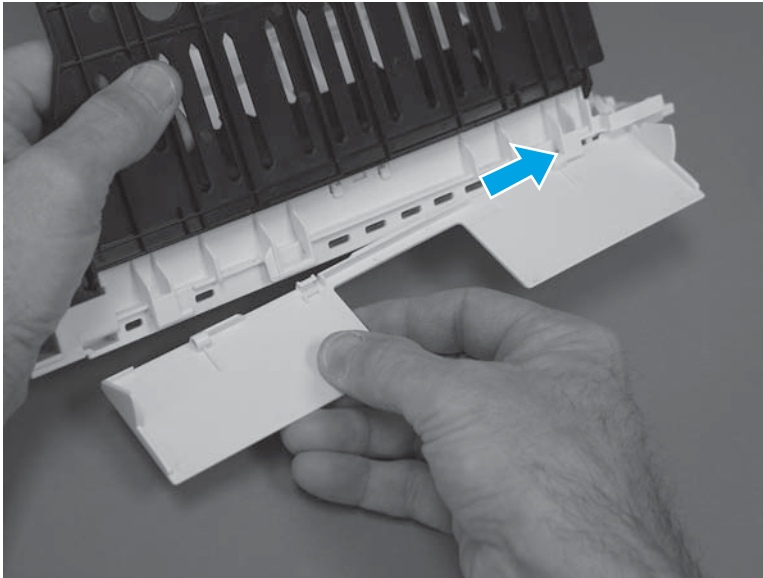

2. Carefully flex the cover to engage the left-side hinge pin and holder (callout 1), and the retainer (callout 2).

 **NOTE:** When the cover is correctly installed, it moves freely on the hinge pins.

Figure 1-194 Engage the left-side hinge and retainer

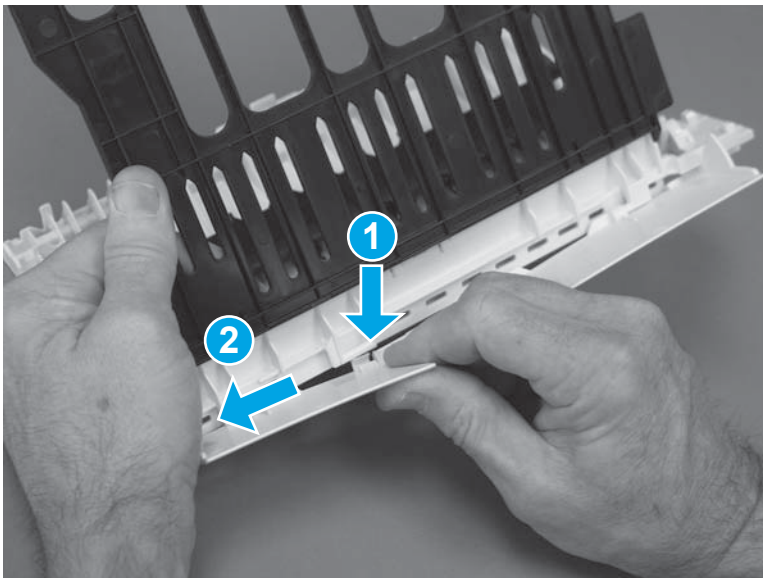

Step 9: Install the rear door assembly

1. At the rear of the printer, position the assembly so that the two tabs (callout 1) are installed in the slots (callout 2) in the chassis.

 **NOTE: Duplex models only:** Slide the duplex tray into the Tray 2 cavity.

Figure 1-195 Install the rear cover



2. Install two screws.

 **NOTE: Duplex models only:** Reach in from the front of the Tray 2 cavity and raise the feed assembly to the up and locked position so that the rear cover will fit flat against the chassis.

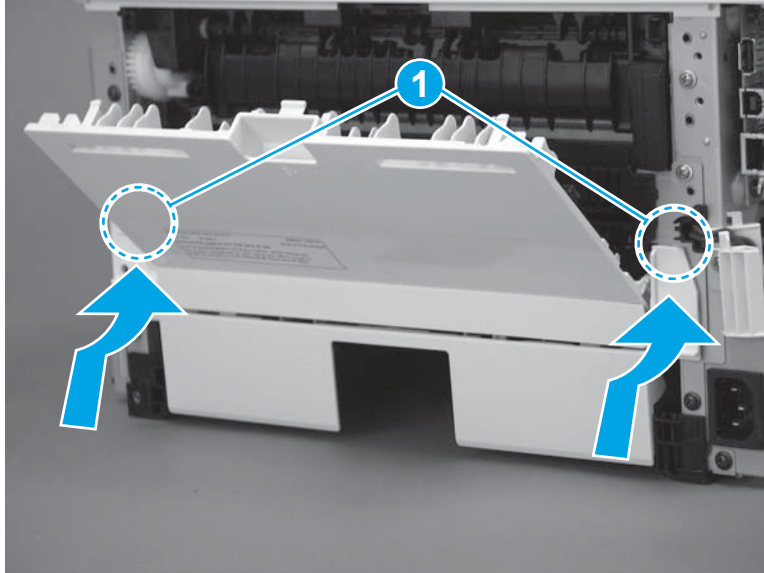
Figure 1-196 Install two screws



Step 10: Install the right cover

1. Position the cover (callout 1) on the printer, and then engage two bosses (callout 2).

Figure 1-197 Install the cover

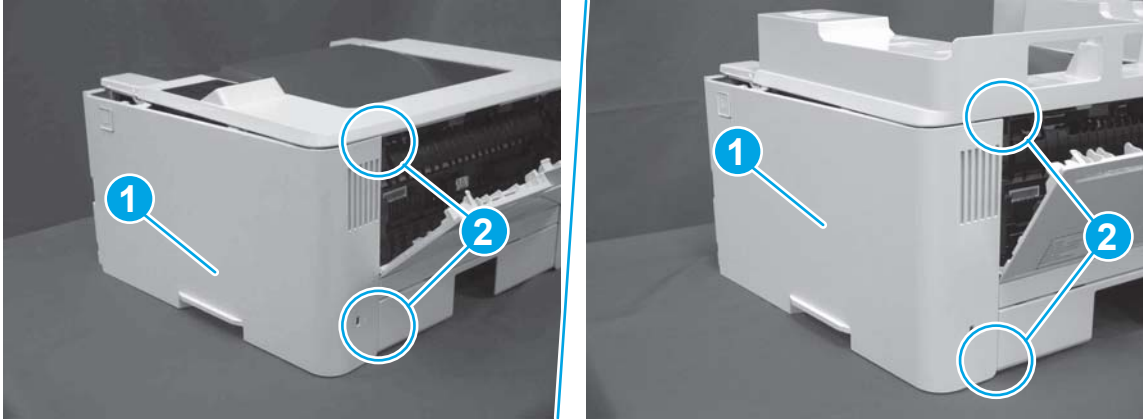

2. Rotate the front of the cover onto the printer (callout 1), engage three (callout 2) tabs, and then engage two bosses (callout 3).

Figure 1-198 Engage two bosses and one tab

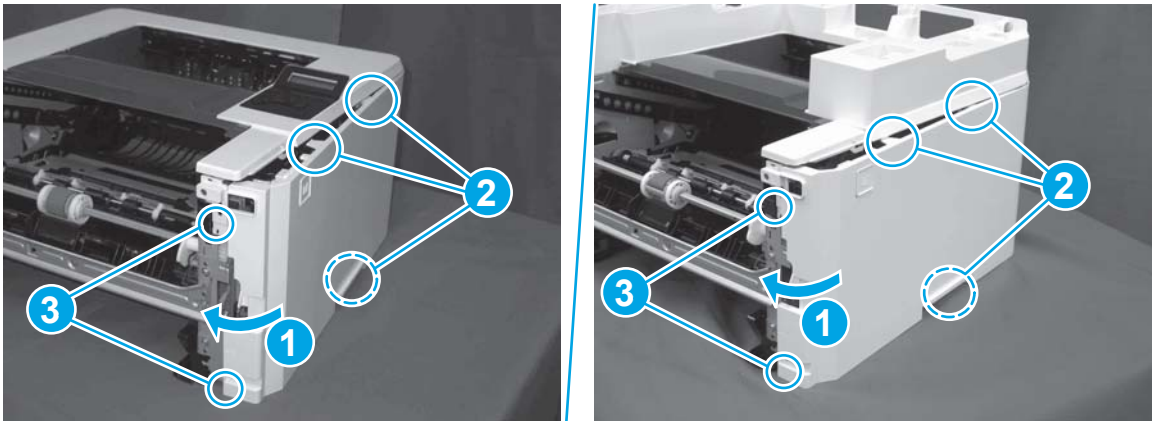

3. Make sure that the power switch (callout 1) and cartridge door assembly button (callout 2) correctly function.

 **NOTE:** Remove, and then reinstall the cover if the switch or button does not correctly function.

Figure 1-199 Check the power switch and cartridge door assembly button



4. Install one screw (callout 1).

Figure 1-200 Install one screw

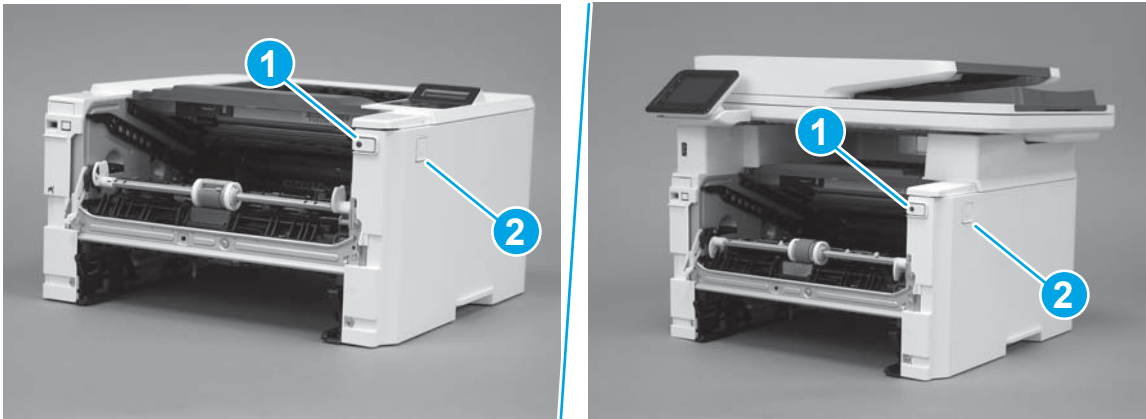

Step 11: Install the left cover

1. At the front of the printer, do one of the following:
 - **M403/M402:** Position the cover on the printer (callout 1), and then engage two bosses (callout 2).
 - **M427/M426:** Position the cover on the printer (callout 3), engage one tab (callout 4), and then engage two bosses (callout 4).

Figure 1-201 Install the cover

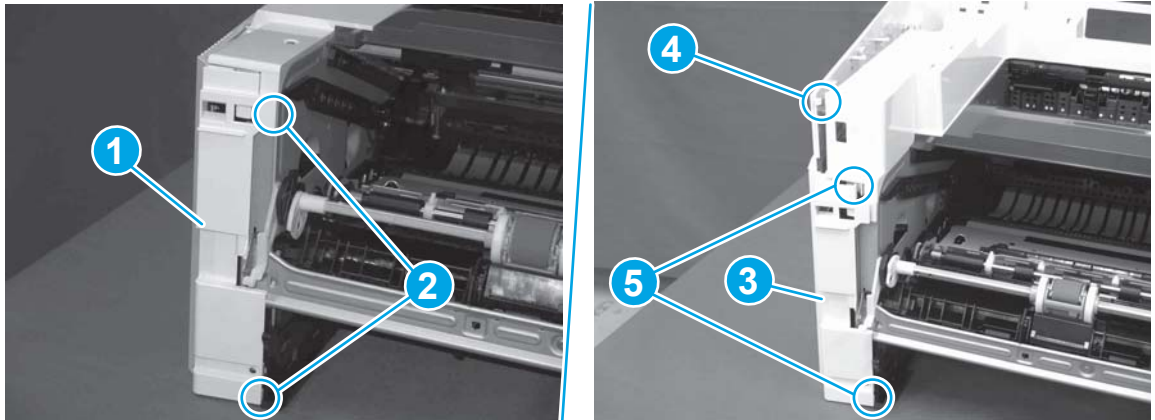

- Carefully rotate the rear of the cover onto the printer (callout 1), engage three tabs (callout 2), and then engage two bosses (callout 3).

Figure 1-202 Engage three tabs and two bosses

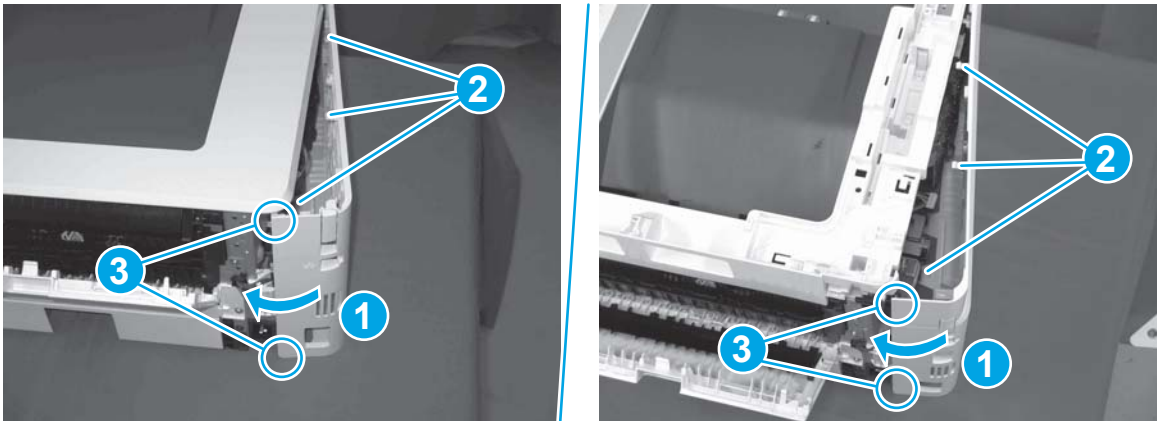

- Install one screw (callout 1).

Figure 1-203 Install one screw

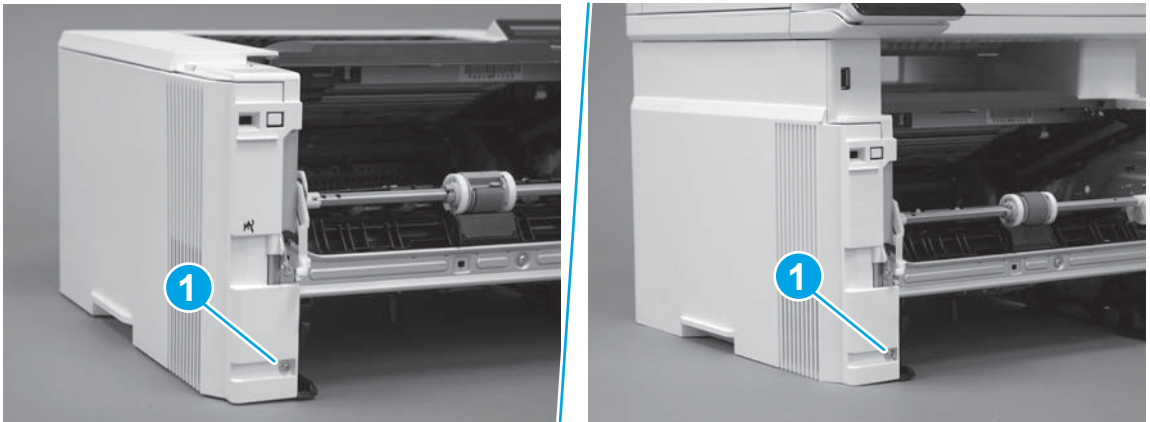

Step 12: Install the cartridge door assembly

 **Reinstallation tip:** After a replacement door is installed, make sure to install the nameplate (supplied in the kit) corresponding to the printer name on the door.

- Position the door close to the printer, and then engage the keyed pin on the left-side retainer arm with the hole in the door.

Figure 1-204 Engage the left-side retainer arm

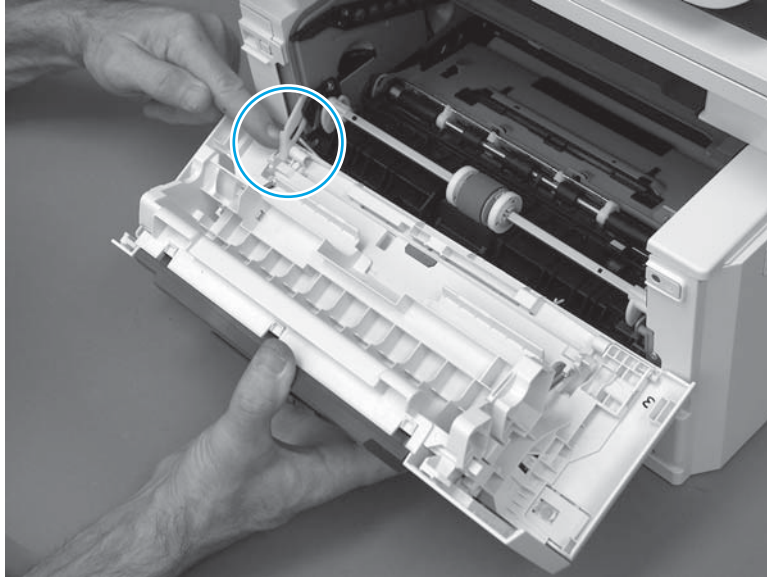

2. Engage the right-side door hinge pin with the hole in the chassis (callout 1).

Figure 1-205 Install the door

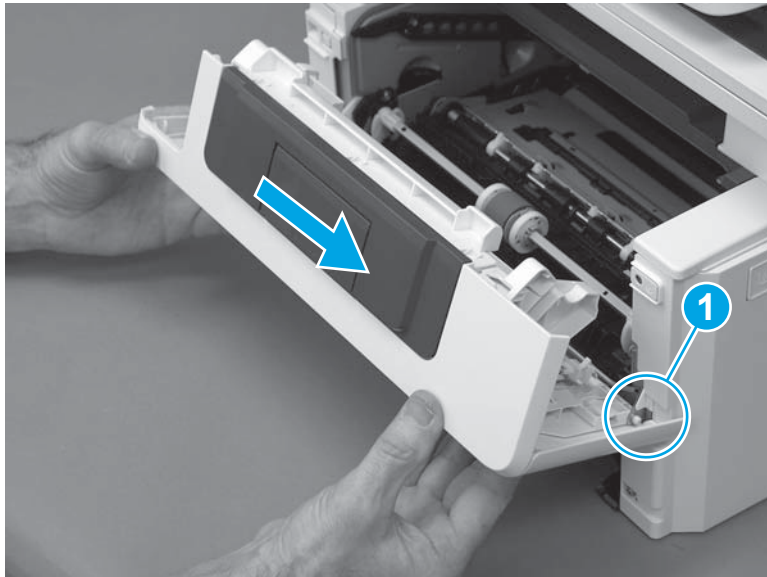

3. Install the link (callout 1).

 **IMPORTANT:** Make sure that the link snaps into place on the arm (callout 2). The link actuates the fuser pressure-release mechanism.

Figure 1-206 Install the pressure-release link

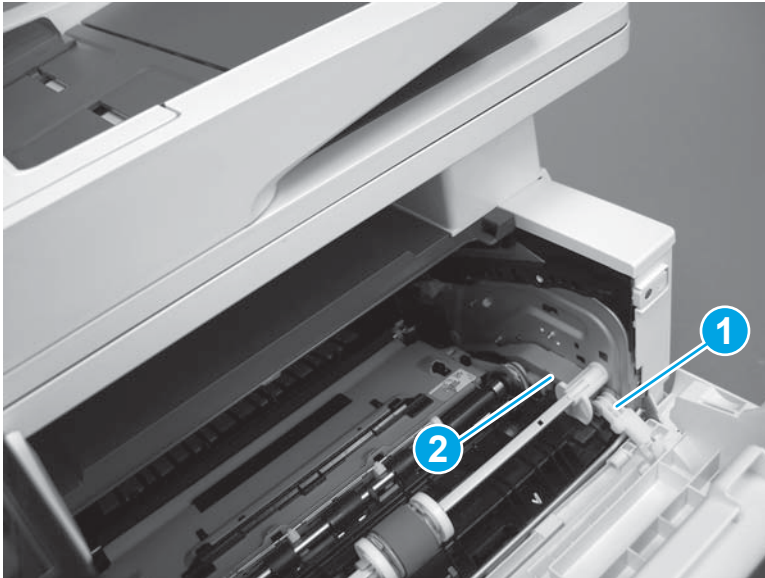

4. Slide the guide into the printer (callout 1), and then make sure that the tab (callout 2) snaps into place to secure the guide to the chassis.

Figure 1-207 Install the guide

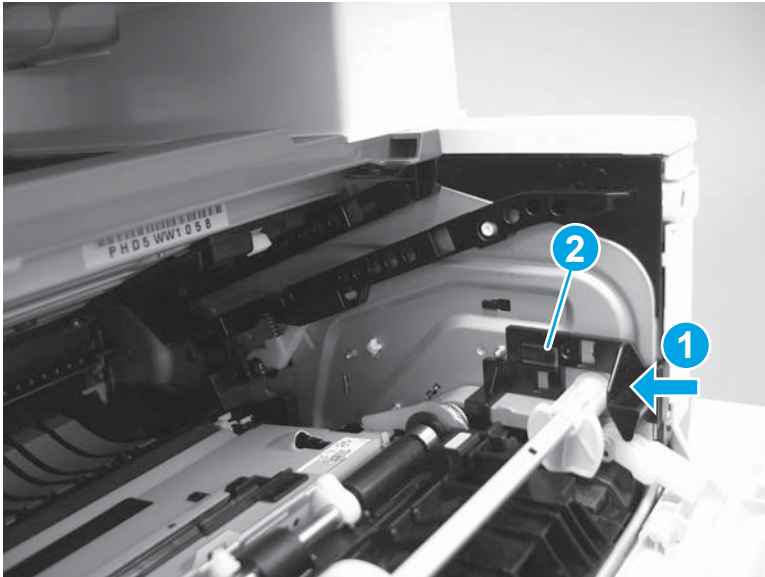

5. Position the shaft on the door, and then align the left-side hinge on the door with the hole in the chassis (callout 1).

Figure 1-208 Align the hinge

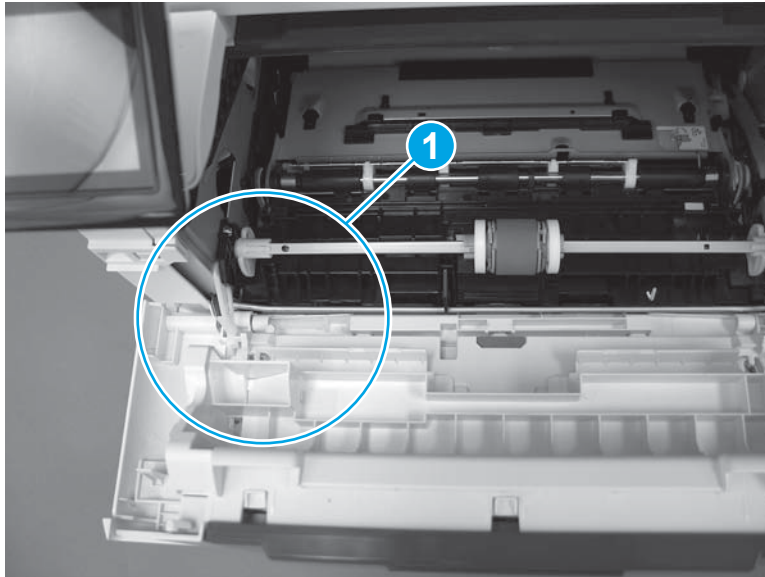

6. Push the shaft towards the left side of the printer to install it (callout 1).

 **Reinstallation tip:** Make sure that the support shaft is fully installed and correctly orientated (callout 2) so that it will not interfere with the door opening and closing.

Figure 1-209 Install the support shaft



Step 13: Install Tray 2

- ▲ Slide the tray straight into the printer to install it.

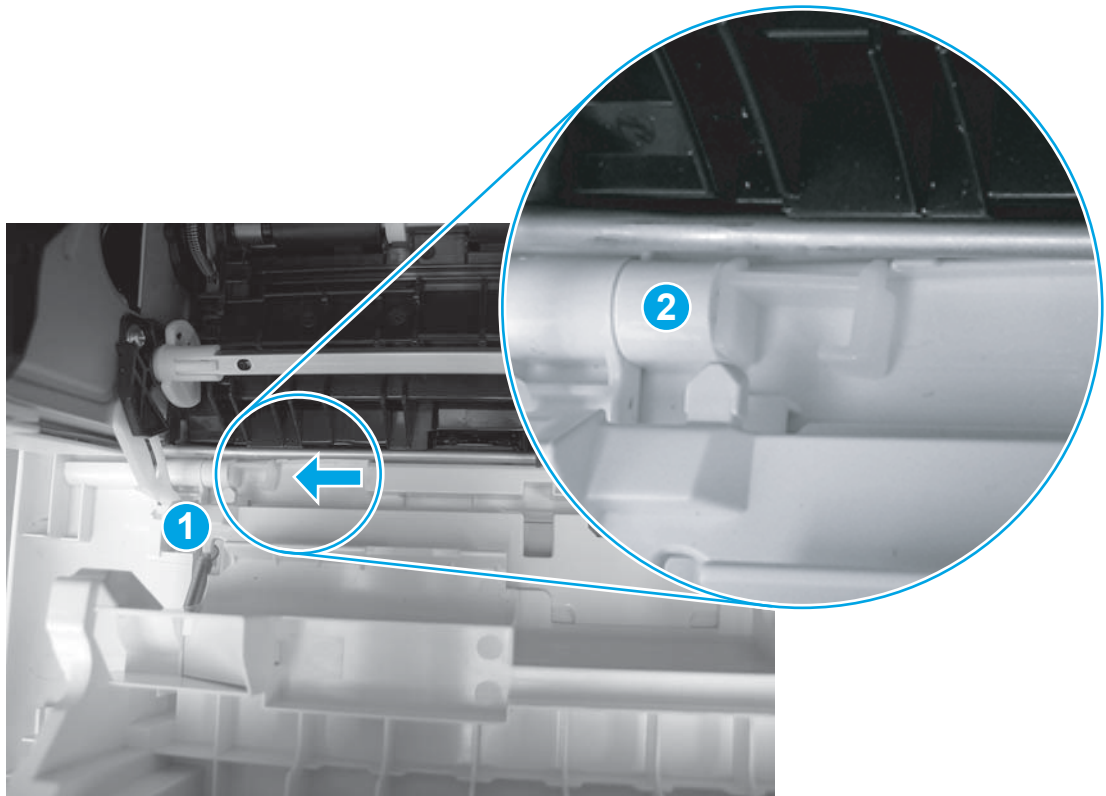
Figure 1-210 Install the tray



Removal and replacement: Top cover (M427/M426)

- [Introduction](#)
- [Step 1: Remove Tray 2](#)
- [Step 2: Remove the cartridge door assembly](#)
- [Step 3: Remove the left cover](#)
- [Step 4: Remove the right cover](#)
- [Step 5: Remove the integrated scanner assembly \(M427/M426\)](#)
- [Step 6: Remove the control panel \(M427/M426\)](#)
- [Step 7: Remove the top cover \(M427/M426\)](#)
- [Step 8: Unpack the replacement assembly](#)
- [Step 9: Remove the cable guide \(M427/M426\)](#)
- [Step 10: Install the cable guide \(M427/M426\)](#)
- [Step 11: Install the top cover \(M427/M426\)](#)
- [Step 12: Install the control panel \(M427/M426\)](#)
- [Step 13: Install the integrated scanner assembly \(M427/M246\)](#)
- [Step 14: Install the right cover](#)
- [Step 15: Install the left cover](#)
- [Step 16: Install the cartridge door assembly](#)
- [Step 17: Install Tray 2](#)

Introduction

This document provides the procedures to remove and replace the top cover (M427/M426).

Before performing service

Turn the printer power off

- Disconnect the power cable.

 **WARNING!** To avoid damage to the printer, turn the printer off, wait 30 seconds, and then remove the power cable before attempting to service the printer.

Use the table below to identify the correct part number for your printer. To order the part, go to www.hp.com/buy/parts.

Top cover (M427/M426) part number	
RC4-3207-000CN	Top cover (M427/M426)

Required tools

- #2 Phillips screwdriver with a magnetic tip.
- Small flat-blade screw driver

After performing service

Turn the printer power on

- Connect the power cable.
- Use the power switch to turn the power on.

Post service test

Make sure that the printer initializes to a **Ready** state.

Print a configuration page to make sure that the printer is functioning correctly.

Step 1: Remove Tray 2

- ▲ Pull the tray straight out of the printer to remove it.

Figure 1-211 Remove the tray



Step 2: Remove the cartridge door assembly



NOTE: If the toner cartridge was not removed prior to servicing the printer, remove it now.

1. Release one tab (callout 1), and then slide shaft (callout 2) in the direction the arrow indicates and remove it.



TIP: It might be easier to release the support shaft by using a small flat-blade screwdriver.

Figure 1-212 Release the support shaft

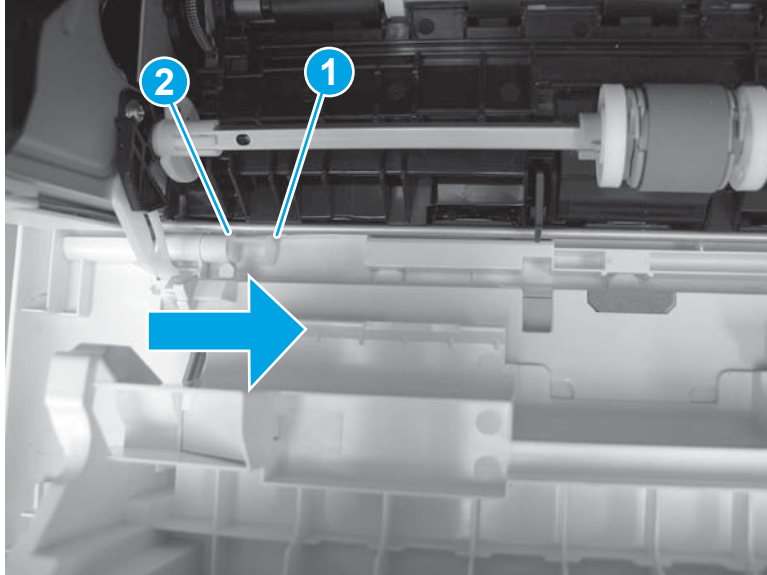

2. Release one tab (callout 1), and then slide the guide (callout 2) in the direction the arrow indicates and remove it.

Figure 1-213 Remove the guide

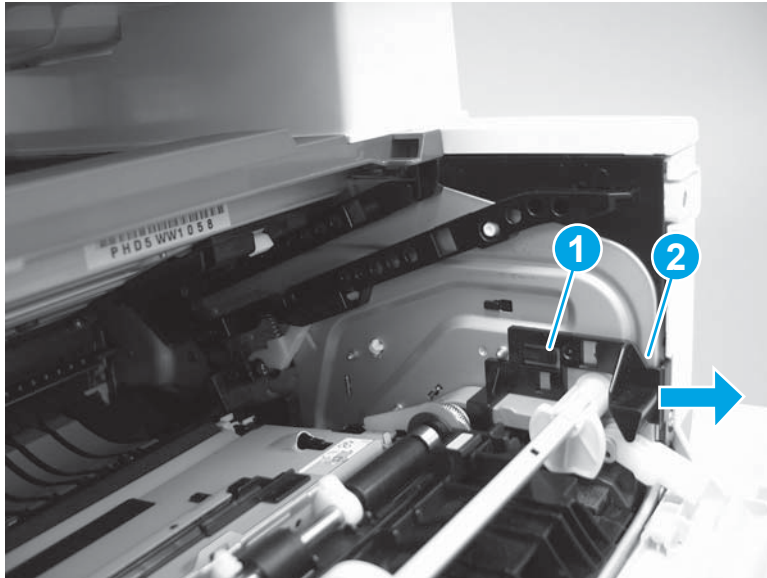

3. Remove the link arm (callout 1).

Figure 1-214 Remove the link arm

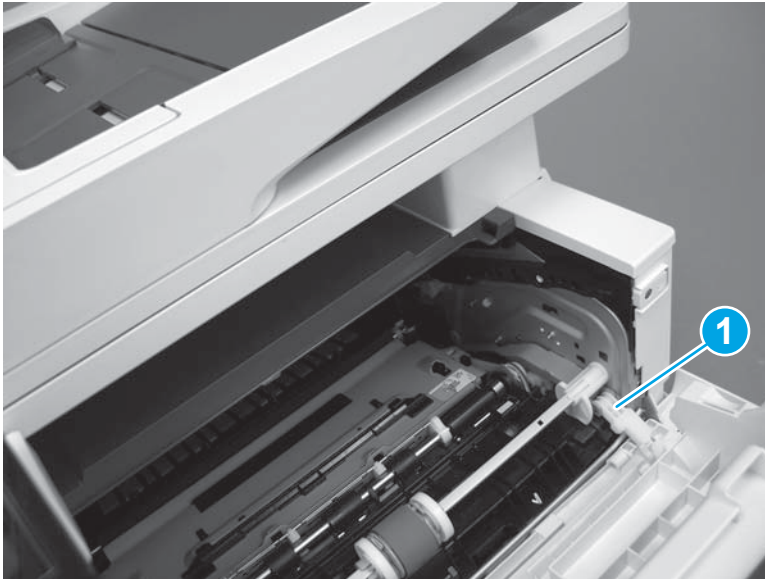

4. Slide the cartridge door assembly (callout 1) in the direction the arrow indicates and remove it.

Figure 1-215 Remove the door

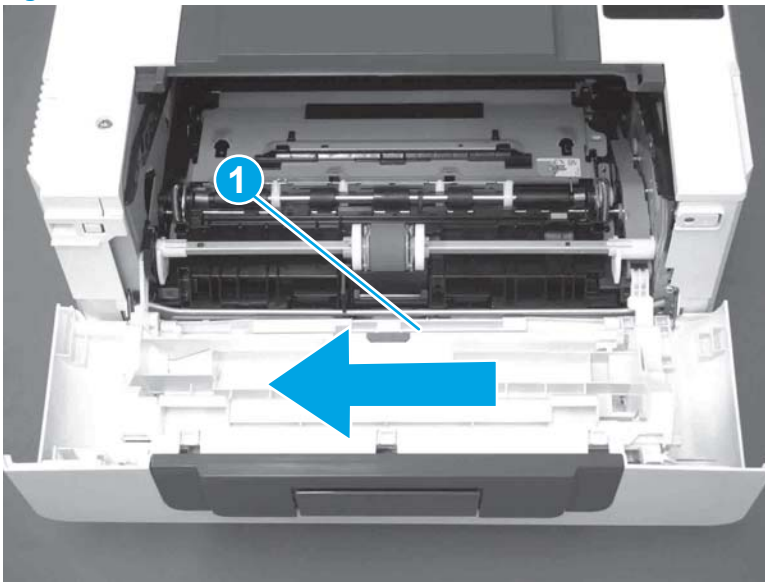

5. Remove the link (callout 1) from the cartridge door assembly (callout 2).

Figure 1-216 Release the left-side retainer arm

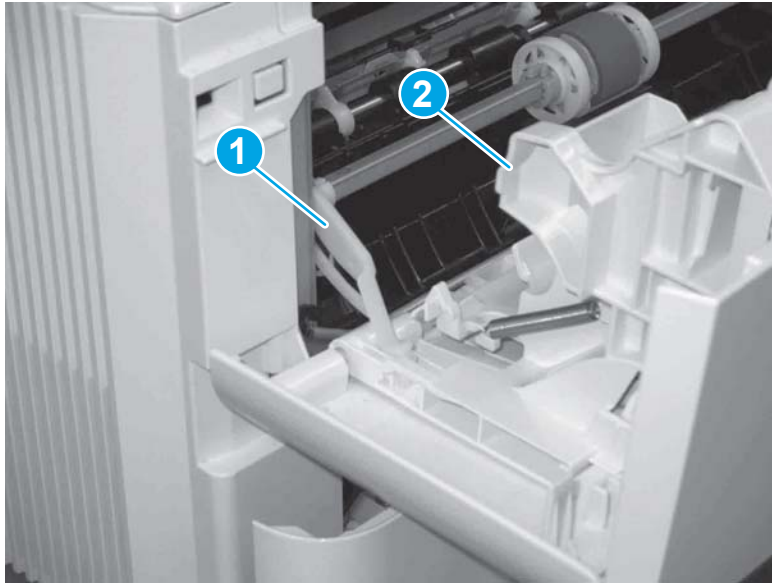

Step 3: Remove the left cover

1. Remove one screw (callout 1).

Figure 1-217 Remove one screw

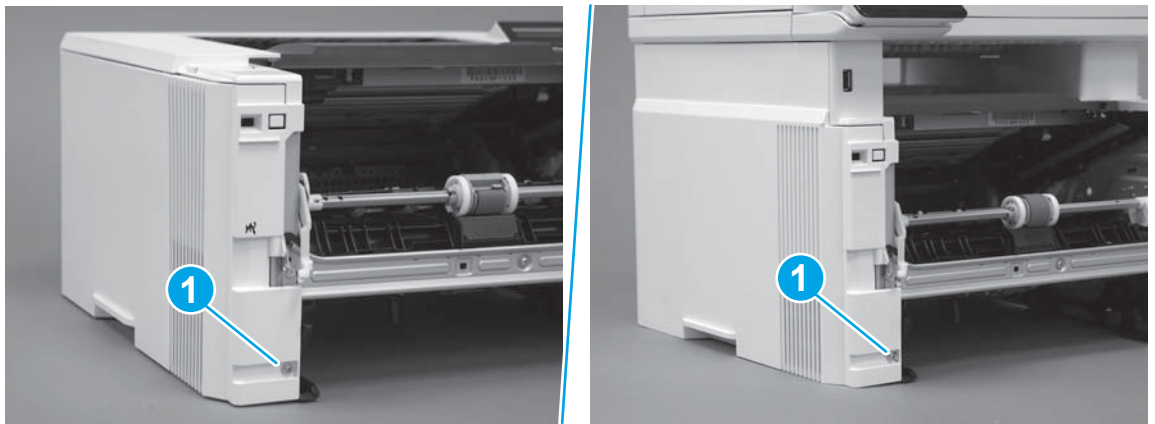

2. Open the rear door, release two bosses (callout 1), and then release three tabs (callout 2).

Figure 1-218 Release two bosses and three tabs

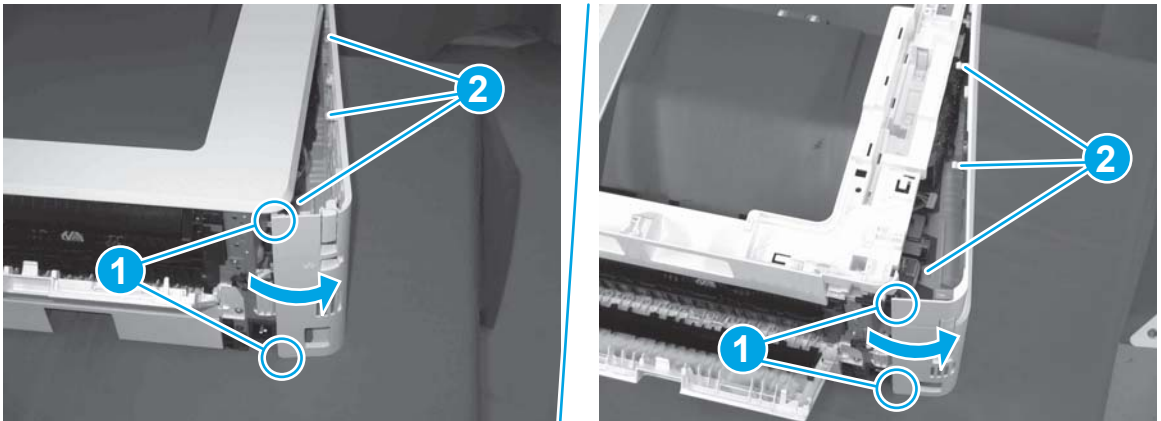

3. At the front of the printer, do one of the following:
 - **M403/M402:** Release two bosses (callout 1), and then remove the cover (callout 2).
 - **M427/M426:** Release one tab (callout 3), two bosses (callout 4), and then remove the cover (callout 5).

CAUTION: Be careful when releasing the upper bosses on the M427/M426 cover. One portion of the cover (callout 6) is fragile and is easily broken.

Figure 1-219 Remove the cover

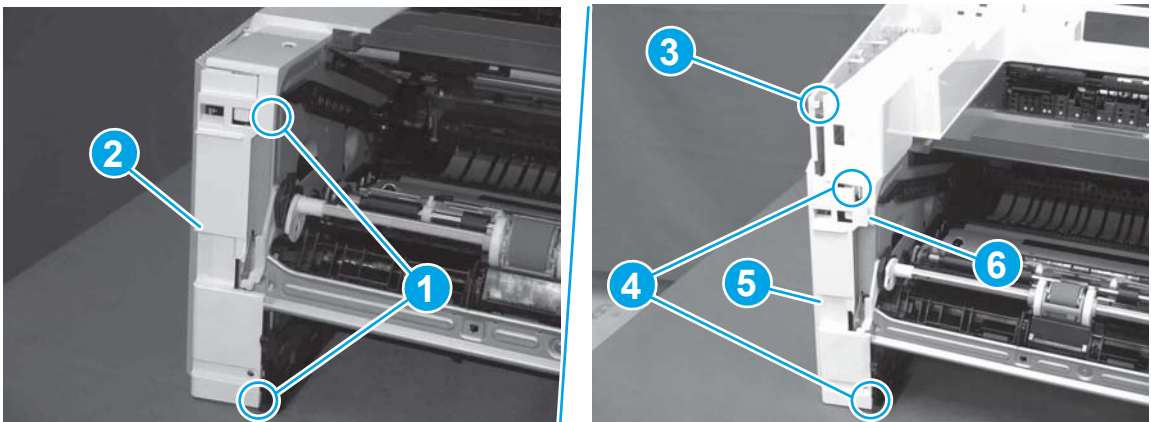

Step 4: Remove the right cover

1. Remove one screw (callout 1).

Figure 1-220 Remove one screw

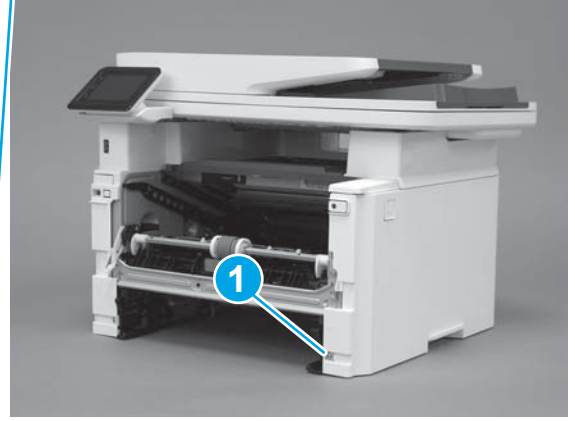
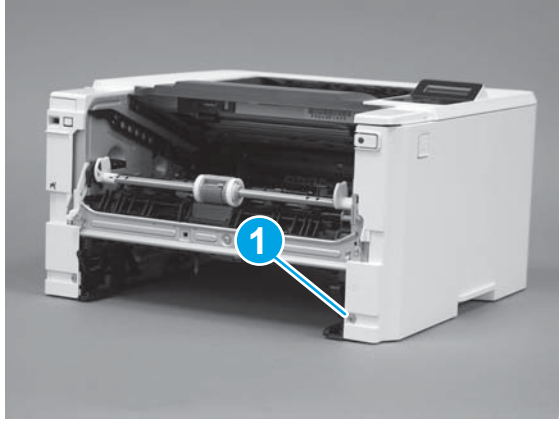

2. At the front of the printer, release two bosses (callout 1), and then release three tabs (callout 2).

Figure 1-221 Release two bosses and three tabs

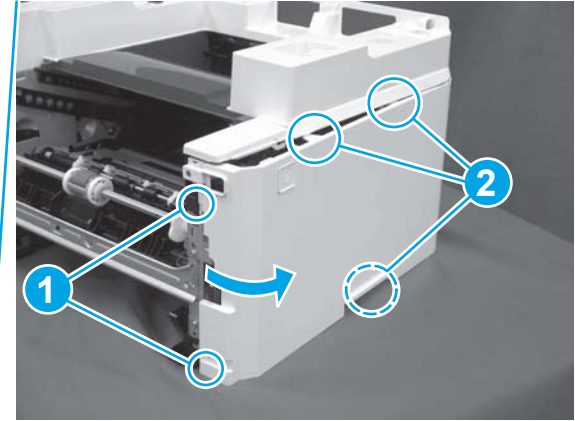
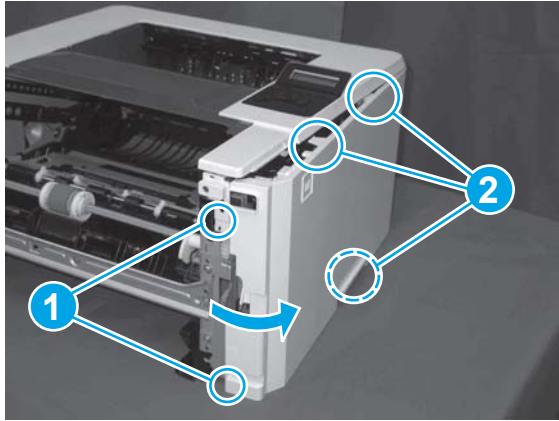

3. Open the rear door, release two bosses (callout 1), and then remove the cover (callout 2).

Figure 1-222 Remove the cover

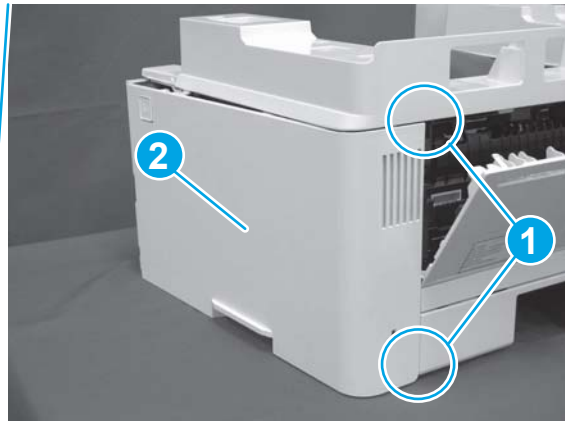
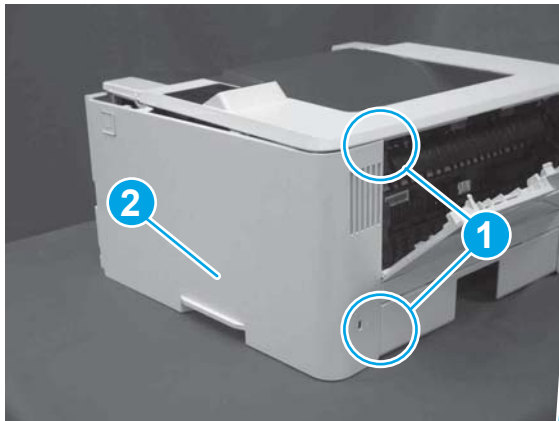

Step 5: Remove the integrated scanner assembly (M427/M426)

 **NOTE:** M427/M426 models only. The integrated scanner assembly (ISA) includes the sub-scanner assembly (SSA) and the automatic document feeder (ADF).

1. Raise the ISA.

Figure 1-223 Raise the ISA

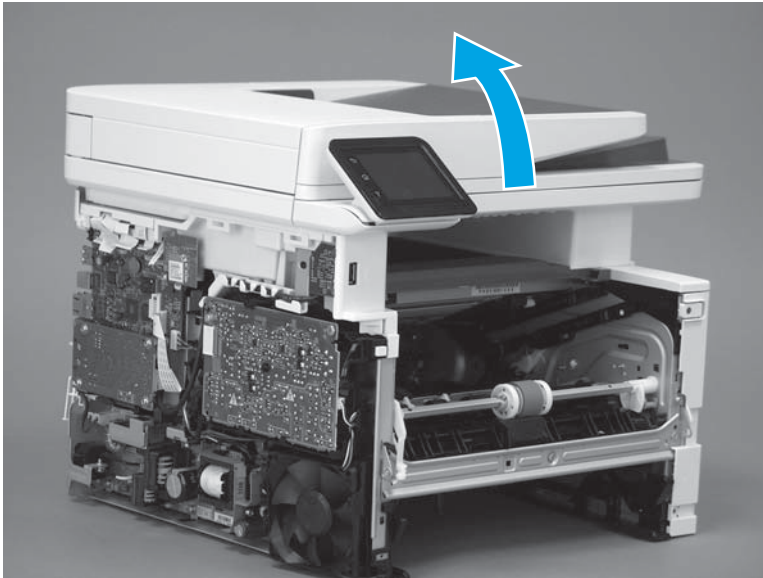

2. Release the ISA flat-flexible cable (FFC) cover (callout 1), and then remove it (callout 2).

Figure 1-224 Remove the ISA FFC cover

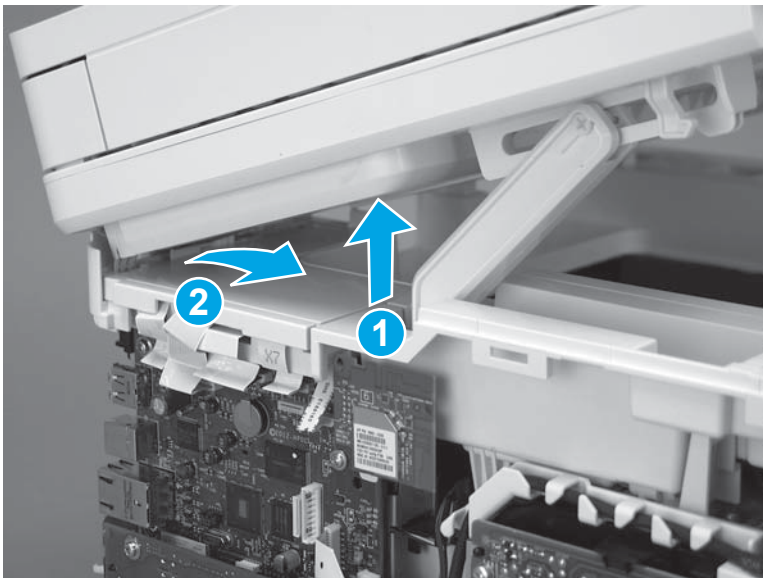

3. Disconnect three FFCs (callout 1), and then remove the ferrite (callout 2) from the holder.

CAUTION: The ferrite is not captive on the FFC. Do not lose the ferrite while handling the ISA.

Figure 1-225 Disconnect three FFCs

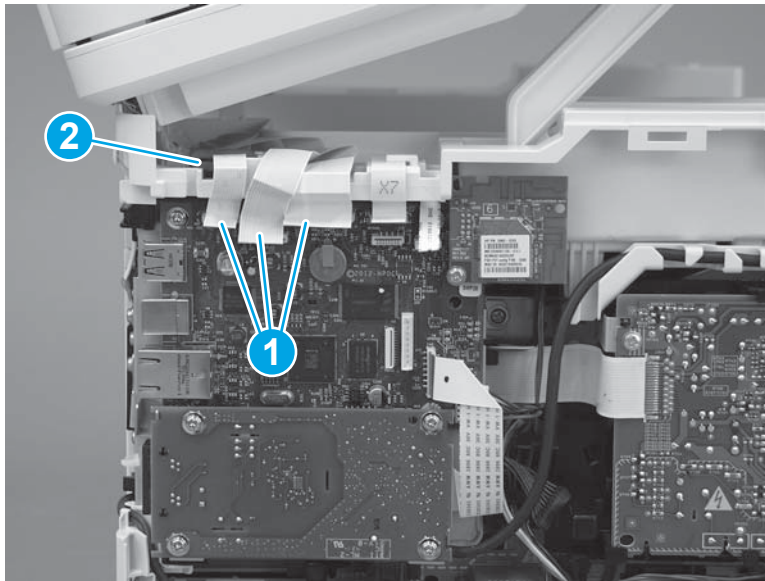

4. Remove one screw (callout 1).

Figure 1-226 Remove one screw

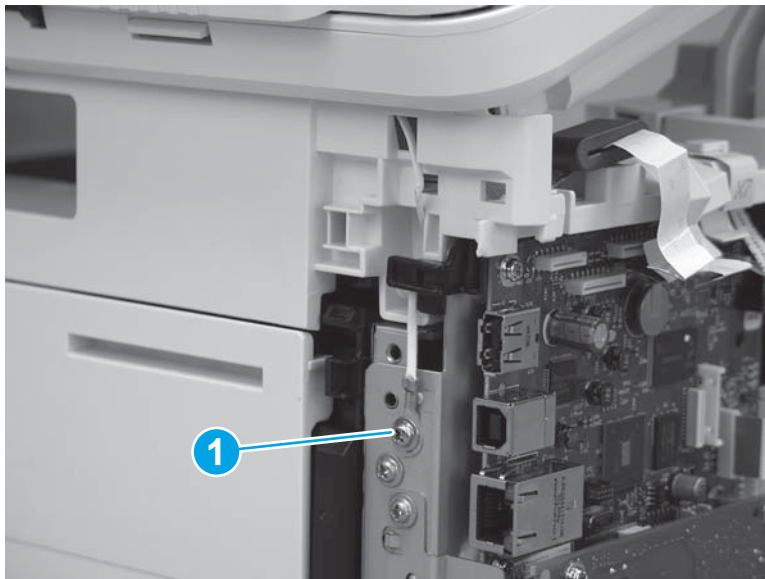

5. Pass the ground wire through the opening in the top cover.

Figure 1-227 Pass the wire through the opening

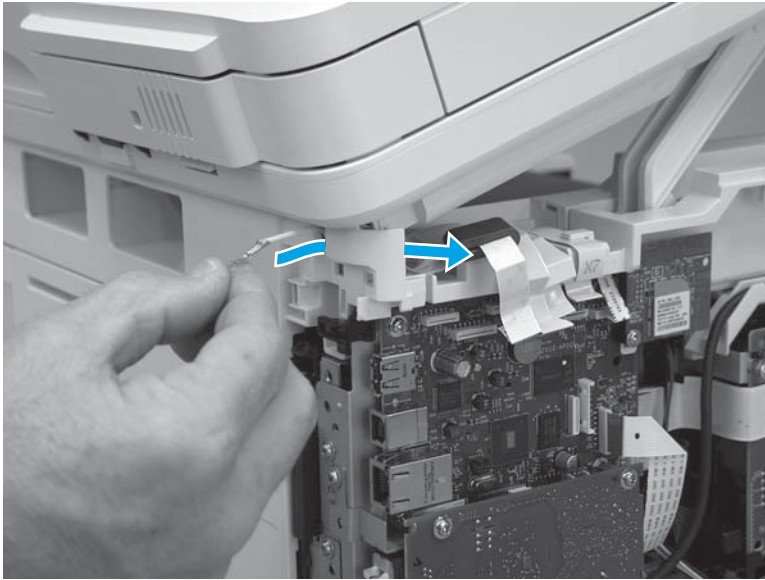

6. Release one tab (callout 1), and then rotate the ISA slider pin (callout 2) towards the front of the printer to release it.

Figure 1-228 Release one tab and rotate the slider pin

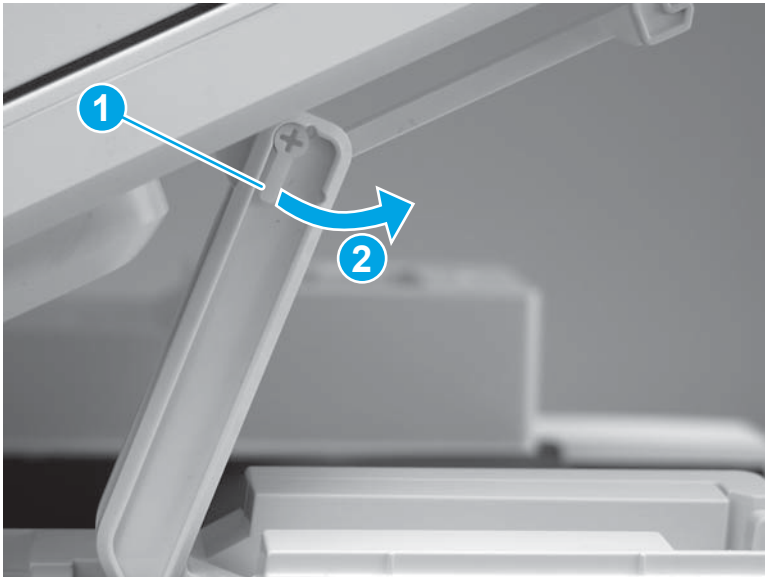

7. Remove the slider pin.

Figure 1-229 Remove the slider pin

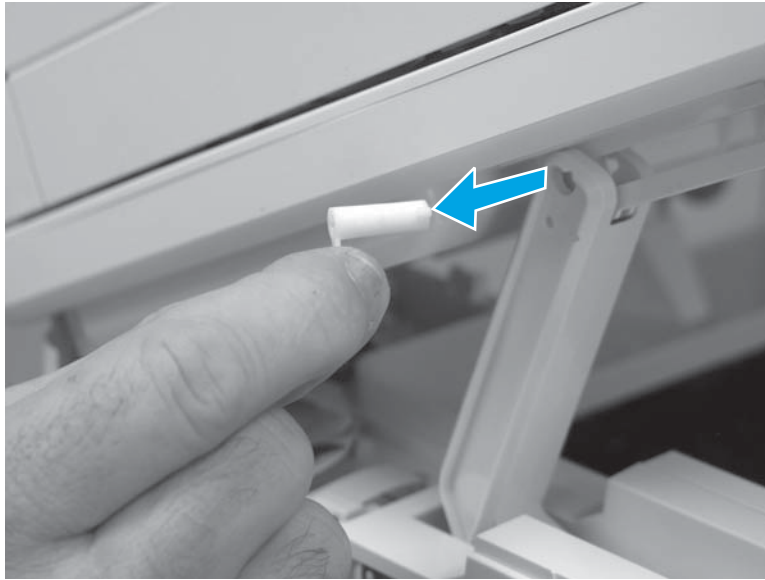

8. Rotate the ISA towards the rear of the printer until it stops.

Figure 1-230 Rotate the ISA towards the rear of the printer



9. Slide the ISA as shown to release it.

Figure 1-231 Release the ISA

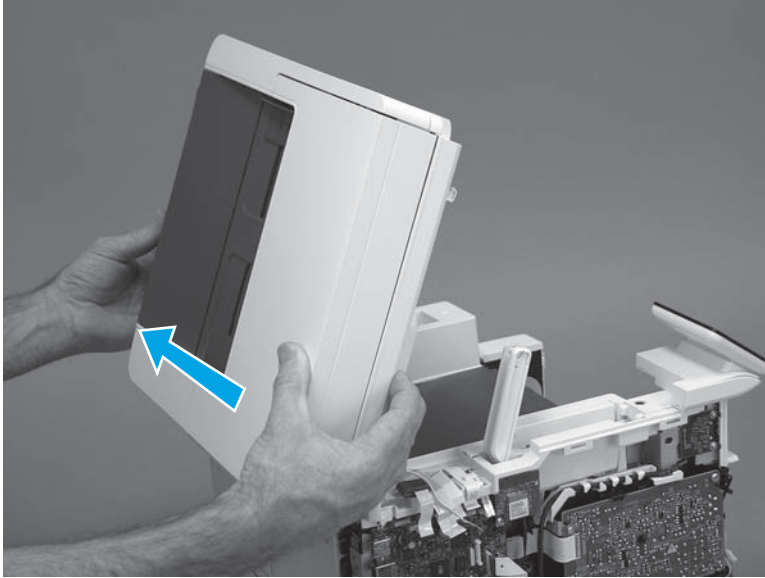

10. Remove the ISA.

Figure 1-232 Remove the ISA

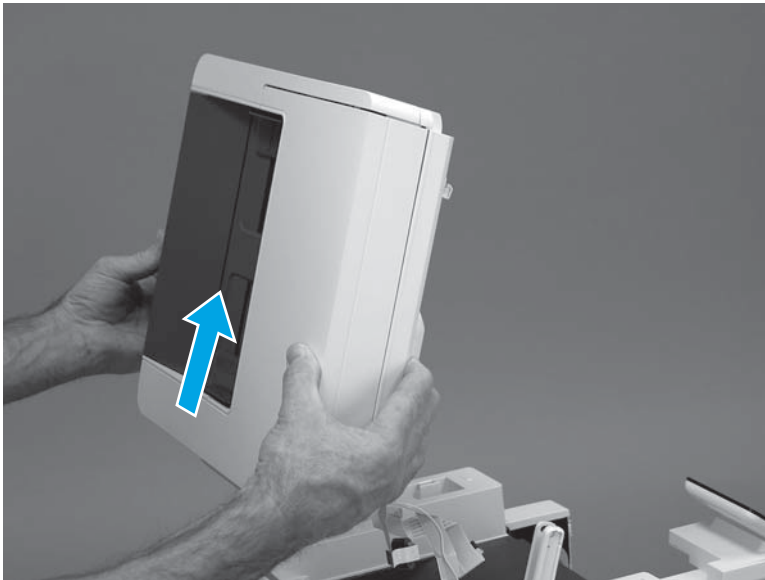

Step 6: Remove the control panel (M427/M426)

1. Disconnect one FFC (callout 1; J114), and then release the FFC from the retainer (callout 2).

Figure 1-233 Disconnect one connector

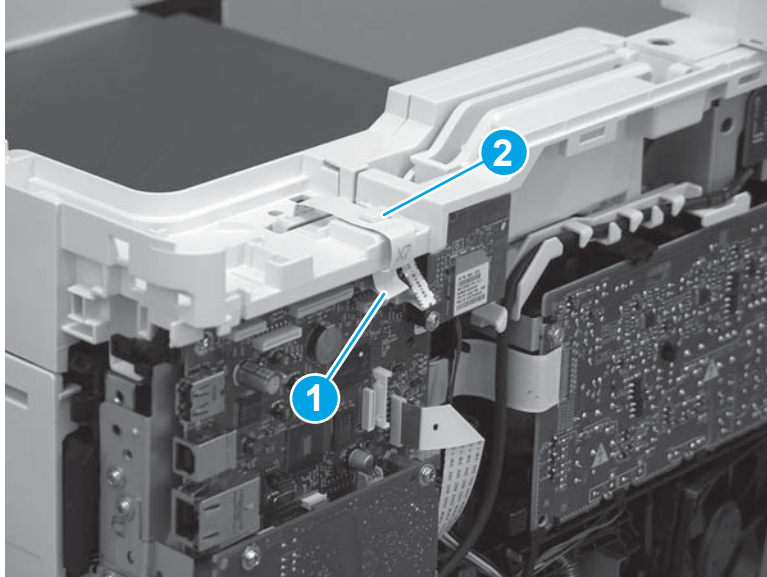

2. Remove one screw (callout 1).

Figure 1-234 Remove one screw

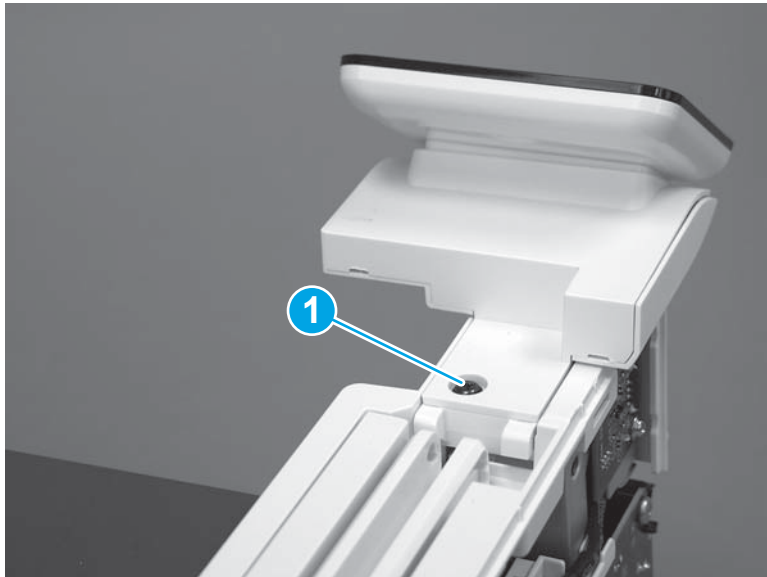

3. Use a small flat-blade screwdriver to release two tabs (callout 1) on the control-panel cable cover.

Figure 1-235 Release two tabs

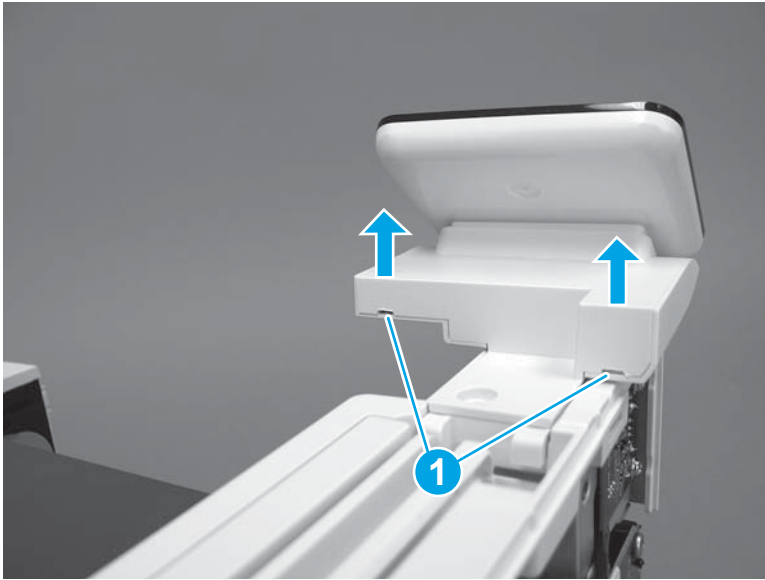

4. Remove the control-panel cable cover.

Figure 1-236 Remove the cover

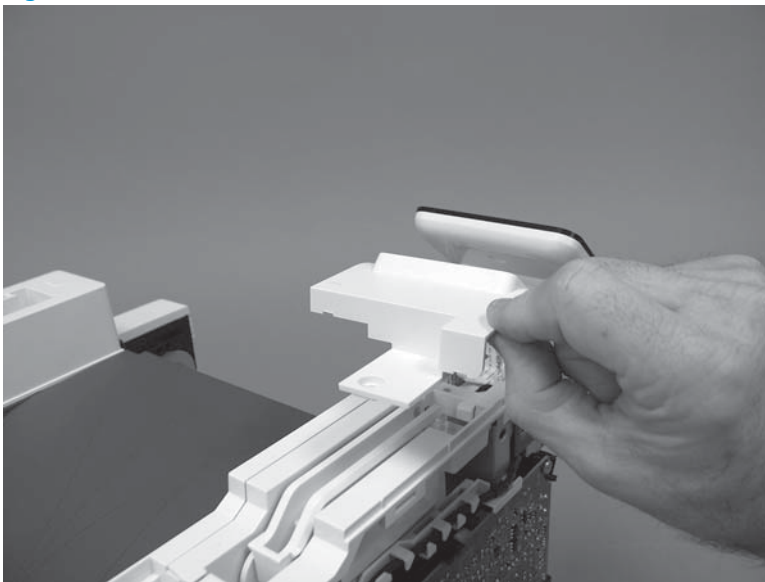

5. Remove one grounding screw (callout 1), and then move the ground cable (callout 2) out of the way.

Figure 1-237 Remove one screw

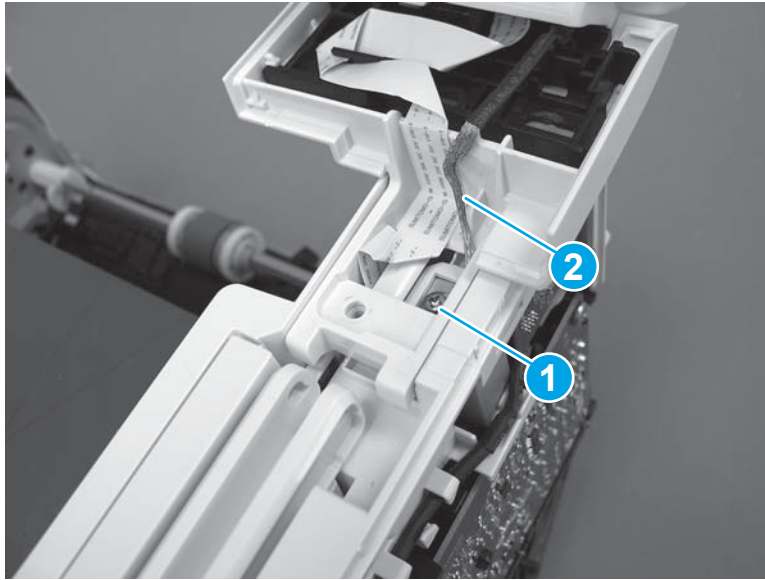

6. Move the FFC out of the way, and then remove two screws (callout 1).

Figure 1-238 Remove two screws

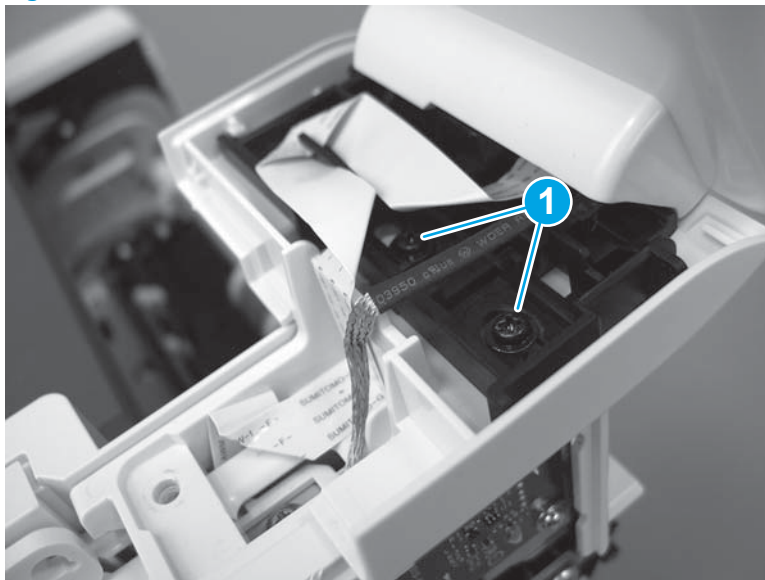

7. Slightly lift up the control-panel assembly to separate it from the top cover.

⚠ CAUTION: The control panel assembly is still connected to the printer by the FFC. Do not attempt to completely remove the assembly.

Figure 1-239 Lift up the control-panel assembly

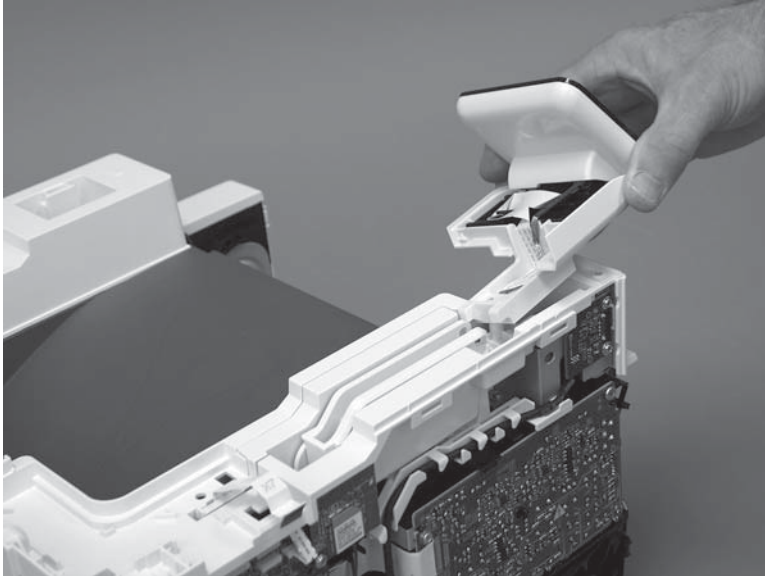

8. Lift up the control-panel FFC cover to remove the control-panel assembly.

Figure 1-240 Remove the control-panel assembly

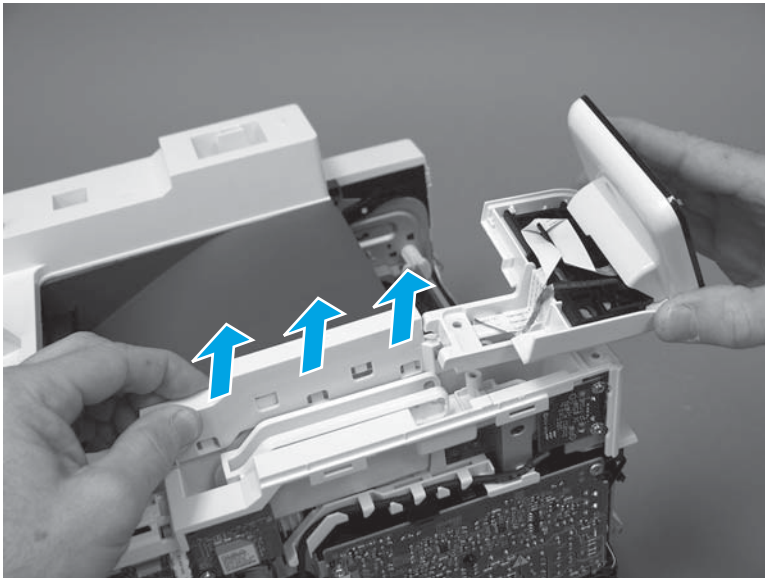

Step 7: Remove the top cover (M427/M426)

1. Release the USB cable (callout 1) from the cable guide.

Figure 1-241 Remove the USB cable

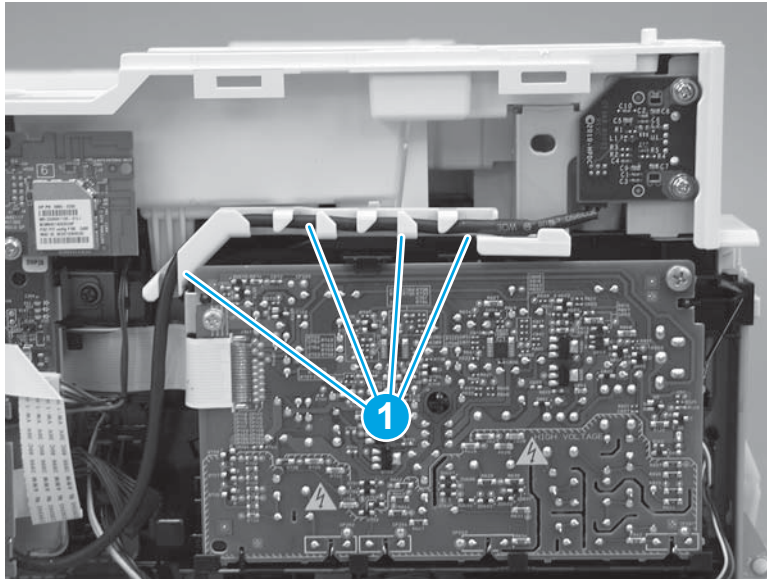

2. Remove five screws (callout 1), release four bosses (callout 2), and then remove the top cover (callout 3).

Figure 1-242 Remove the cover

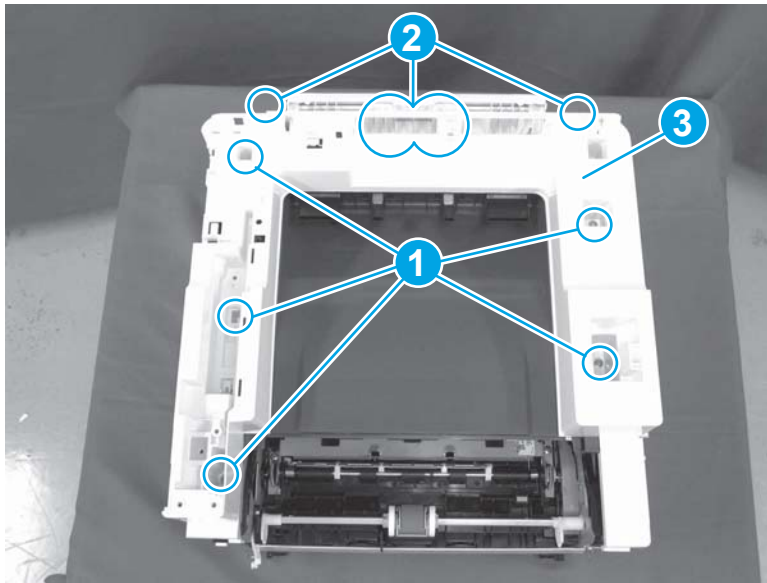

Step 8: Unpack the replacement assembly

Unpack the replacement part from the packaging.

<http://www8.hp.com/us/en/hp-information/environment/product-recycling.html>

 **NOTE:** HP recommends responsible disposal of the defective part.

Figure 1-243 Recycle and unpack

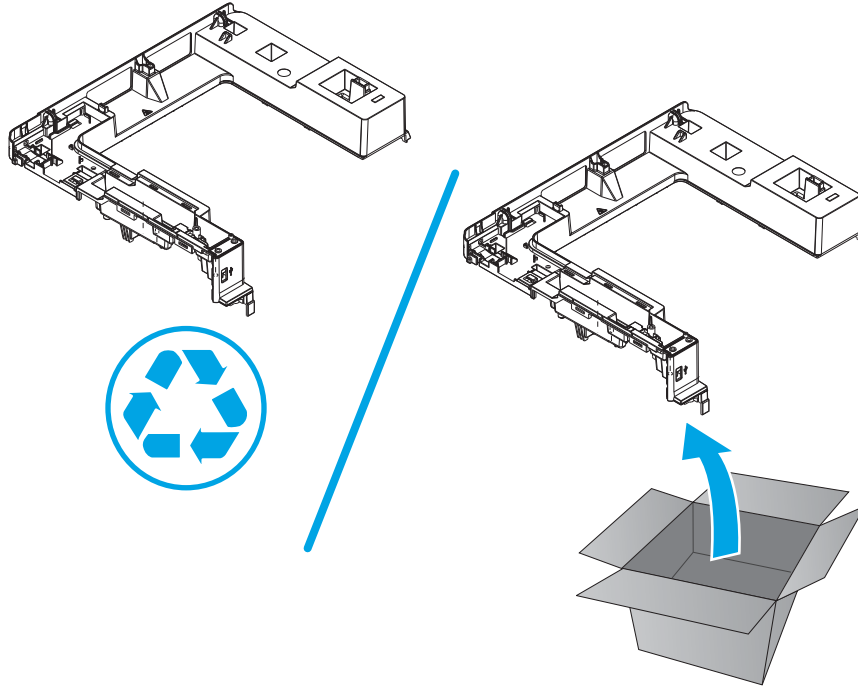

Step 9: Remove the cable guide (M427/M426)

1. Turn the top cover over, and then release one tab (callout 1).

Figure 1-244 Release one tab

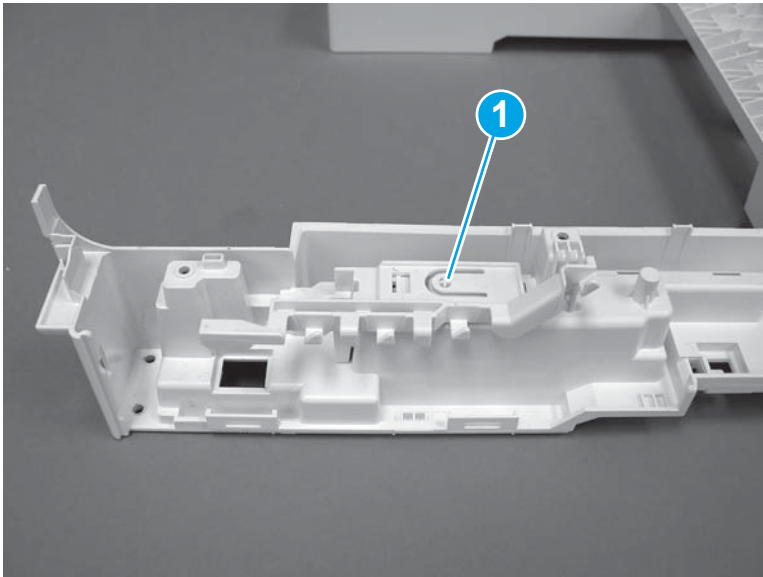

2. Slide the guide as shown to release it.

Figure 1-245 Release the guide

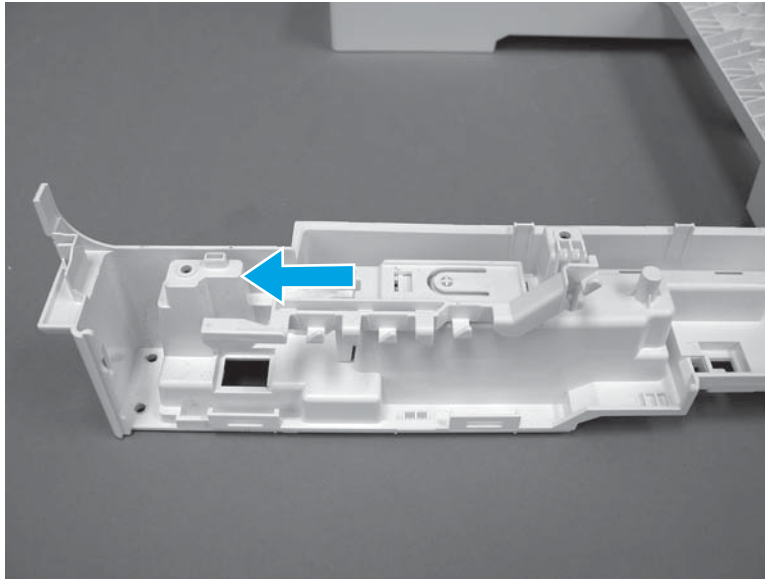

3. Remove the guide.

Figure 1-246 Remove the guide

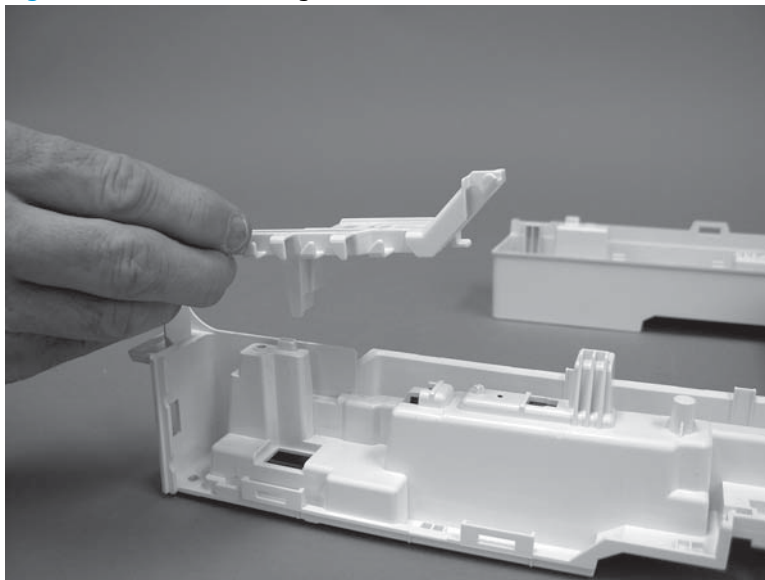

Step 10: Install the cable guide (M427/M426)

1. Position the guide on the printer with the two tabs (callout 1) in the slots (callout 2) in the chassis.

Figure 1-247 Position the guide on the printer

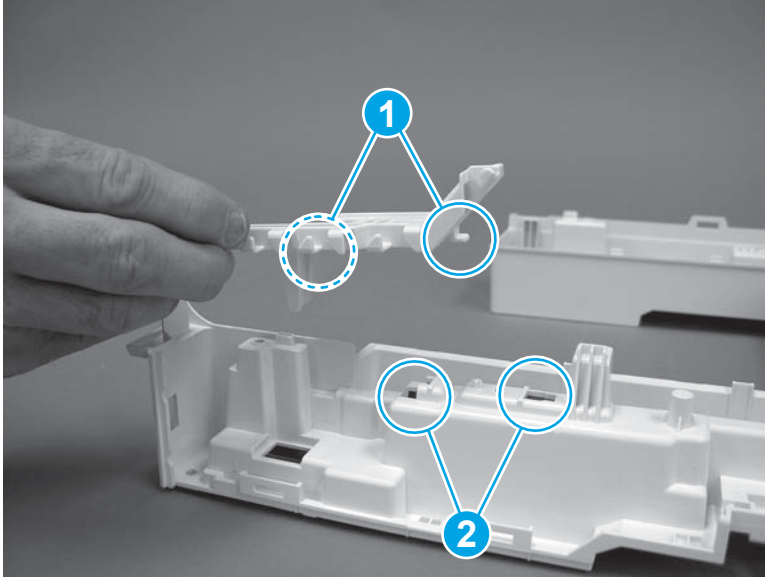

2. Slide the guide as shown (callout 1) to install it.

Figure 1-248 Install the guide

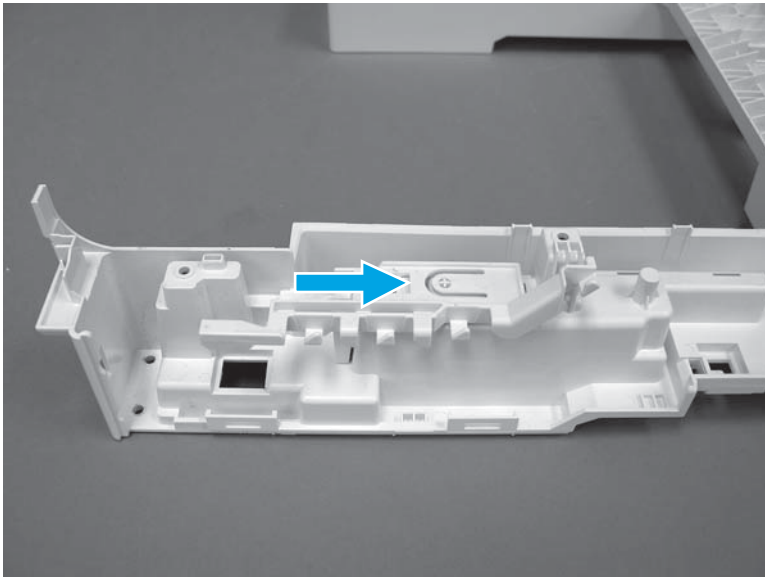

3. Make sure that the tab (callout 1) snaps into place.

Figure 1-249 Check the guide

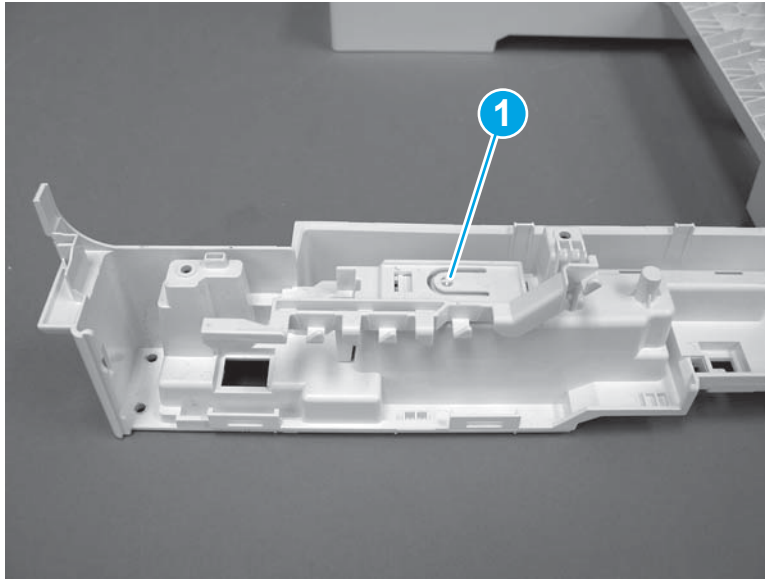

Step 11: Install the top cover (M427/M426)

1. Position the rear edge of the top cover on the printer.

Figure 1-250 Install the cover

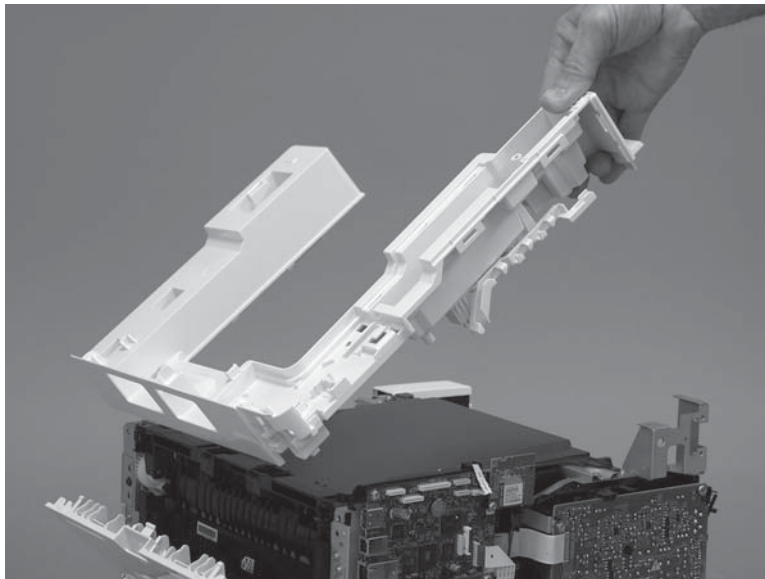

2. Engage four bosses (callout 1).

Figure 1-251 Engage four bosses

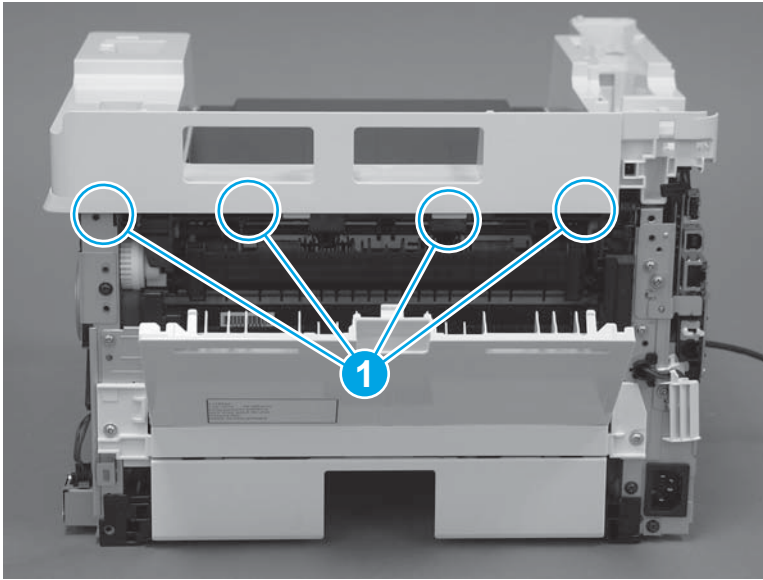

3. Rotate the front edge of the cover down.

Figure 1-252 Rotate the front edge of the cover down

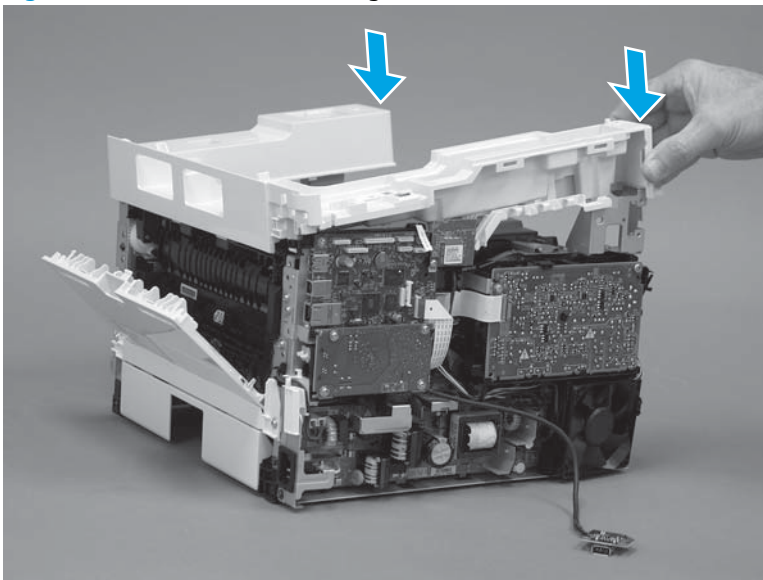

4. Install the USB cable (callout 1) in the guide.

Figure 1-253 Install the USB PCA

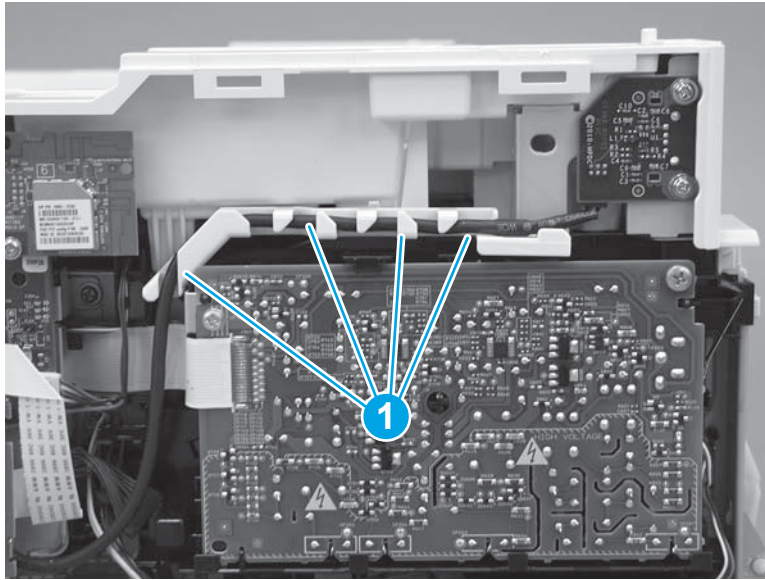

5. Install five screws (callout 1).

Figure 1-254 Install five screws

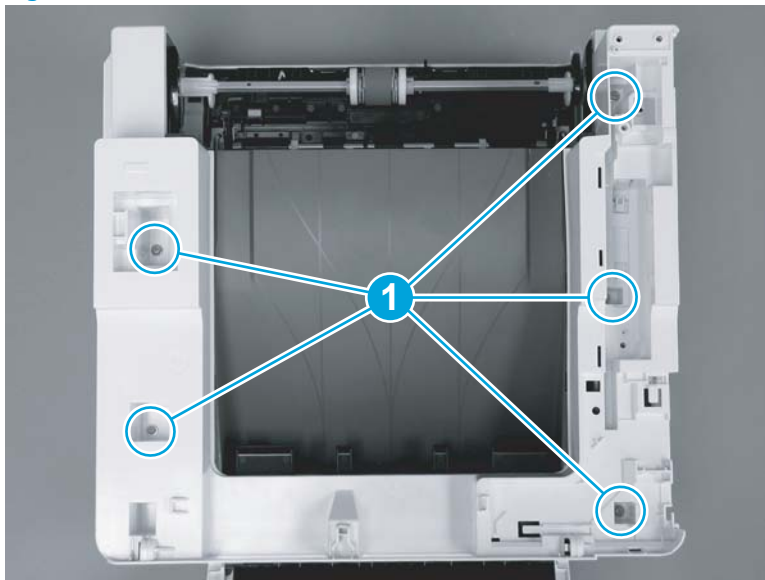

Step 12: Install the control panel (M427/M426)

1. Slide the control-panel FFC cover into the slot in the top cover (next to the document feeder support arm) to install it.

Figure 1-255 Install the control-panel FFC cover

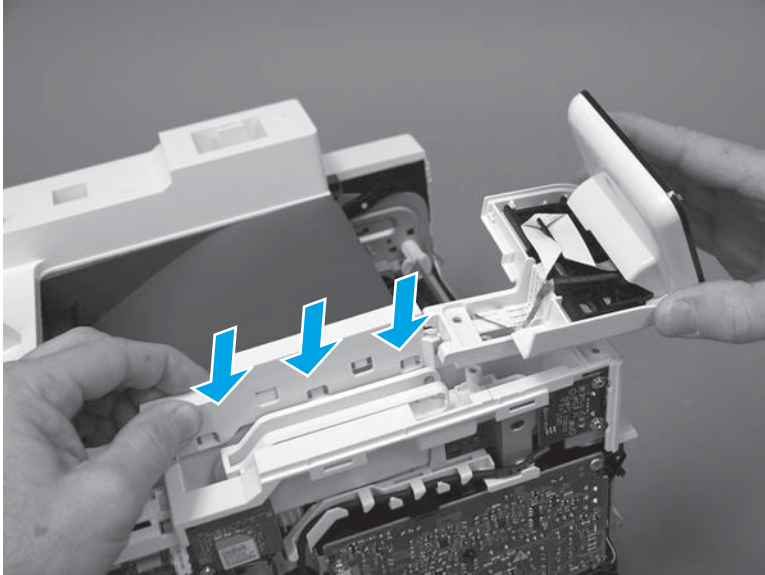

2. Install the control-panel assembly on the top cover.

Figure 1-256 Install the control-panel assembly

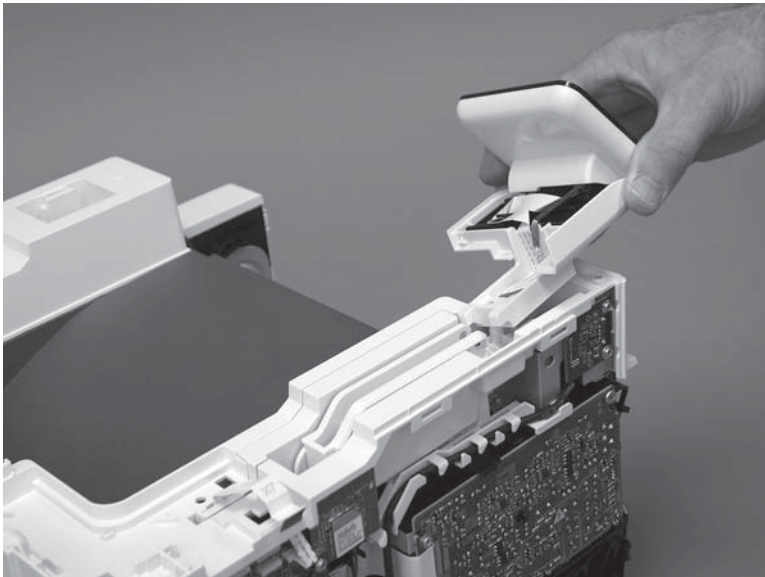

3. Move the FFC out of the way, and then install two screws (callout 1).

Figure 1-257 Install two screws

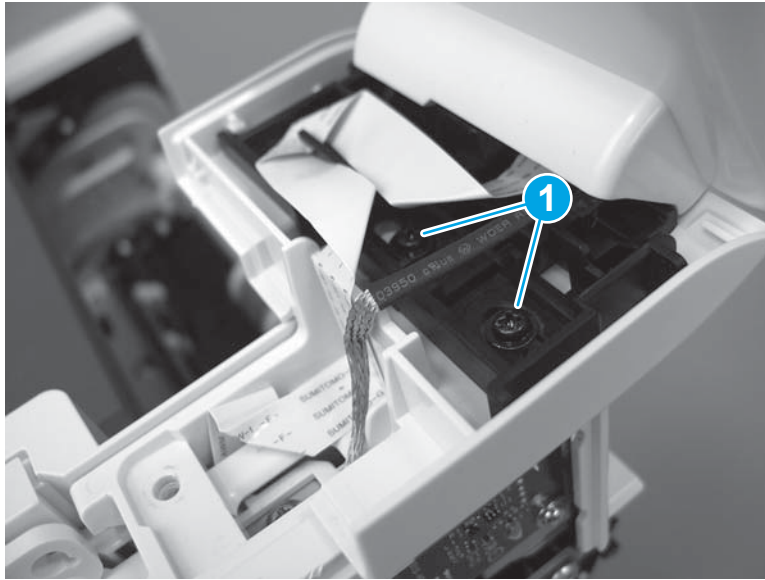

4. Install one grounding screw (callout 1), and then make sure that the ground cable (callout 2) is properly routed.

Figure 1-258 Remove one screw

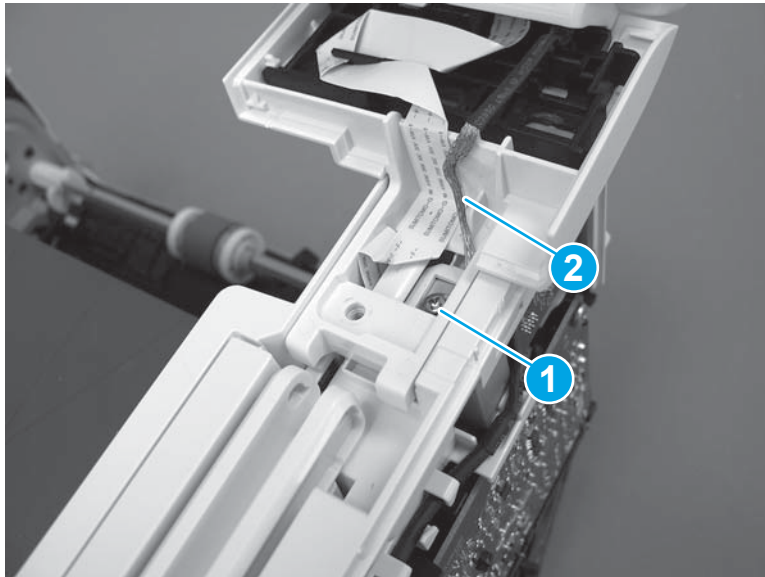

5. Install the control-panel cable cover.

Figure 1-259 Install the cover

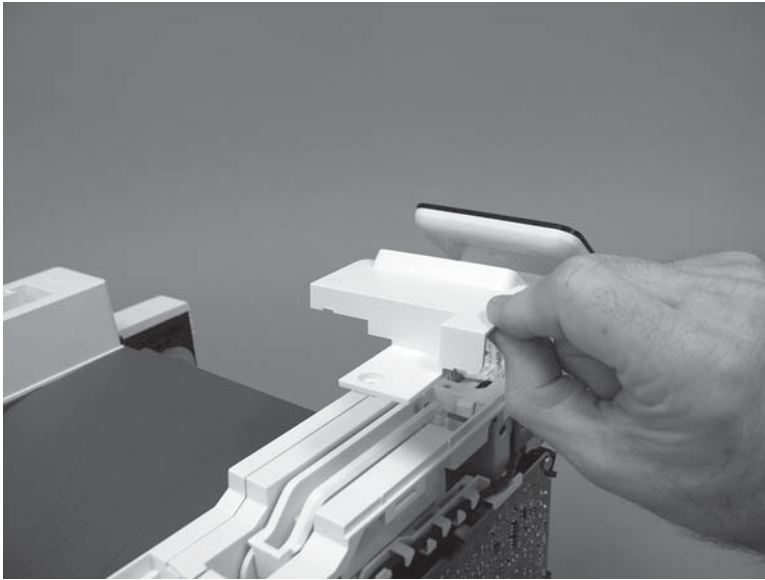

6. Make sure that the two tabs (callout 1) on the cover snap into place.

Figure 1-260 Engage two tabs

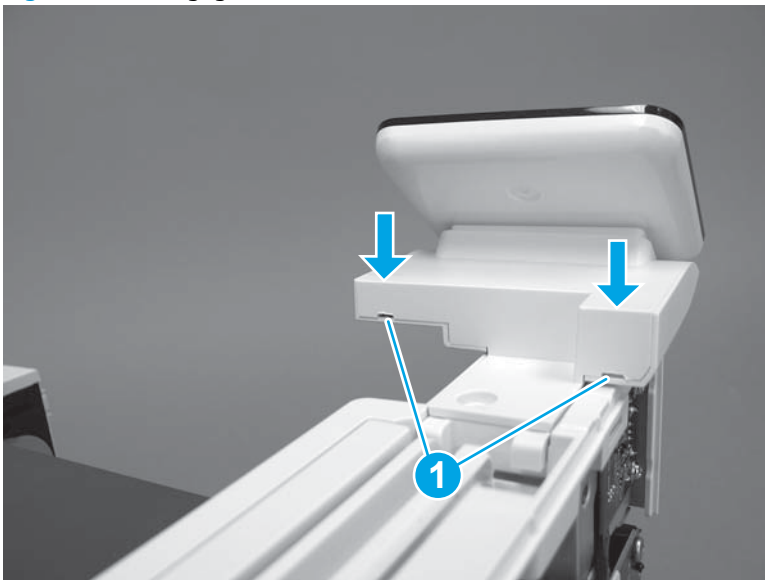

7. Install one screw (callout 1).

Figure 1-261 Install one screw

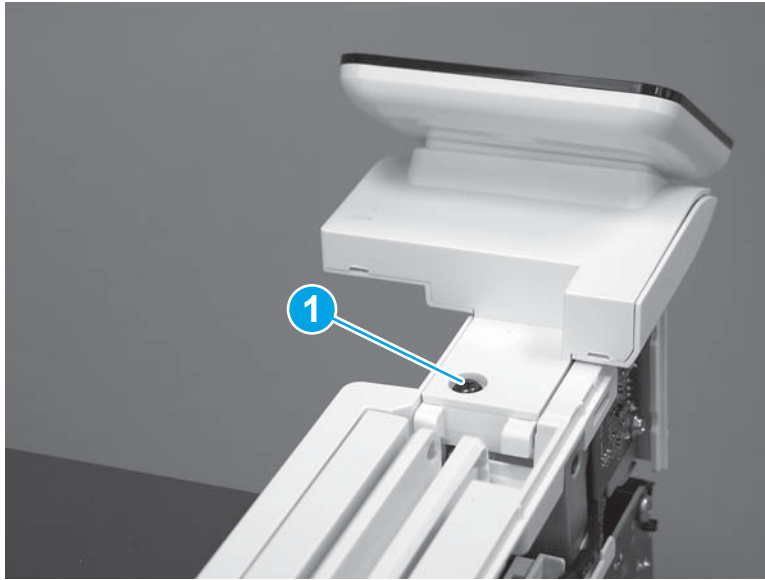

8. Install the FFC in the retainer (callout 1), and then connect one FFC (callout 1; J114).

Figure 1-262 Connect one connector

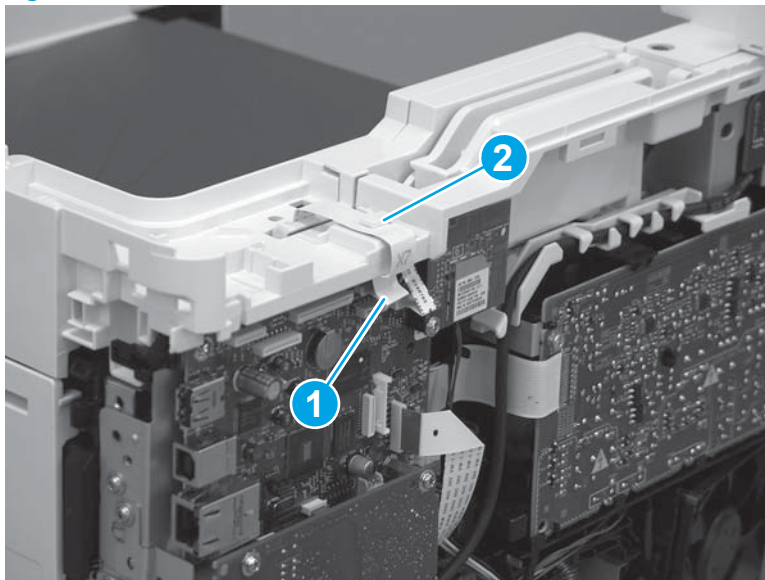

Step 13: Install the integrated scanner assembly (M427/M246)

 **NOTE:** M427/M426 models only. The integrated scanner assembly (ISA) includes the sub-scanner assembly (SSA) and the automatic document feeder (ADF).

1. Position the ISA on the printer.

Figure 1-263 Position the ISA on the printer

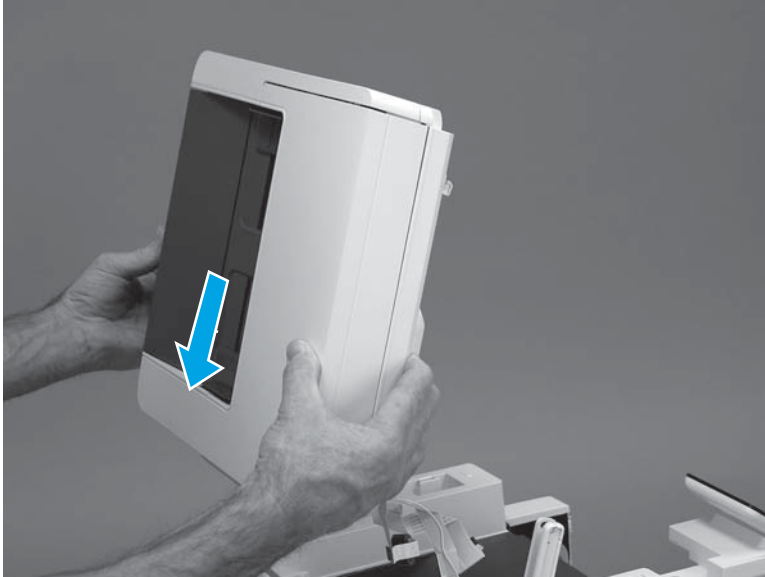

2. Engage the hinge pins on the ISA with the holders in the top cover (callouts 1/2), and then slide the ISA as shown to engage them

Figure 1-264 Engage the hinge pins with the holders

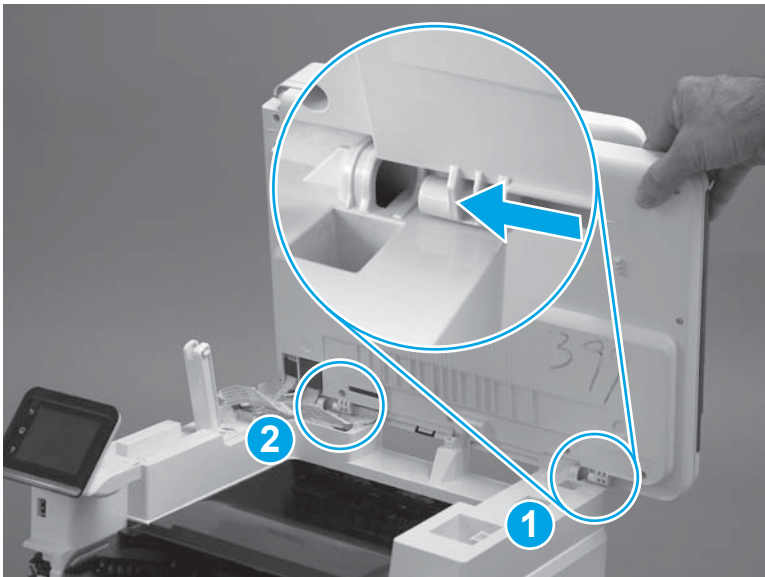

3. Rotate the ISA towards the front of the printer until it rests on the ISA lift assembly (callout 1).

Figure 1-265 Rotate the ISA towards the front of the printer

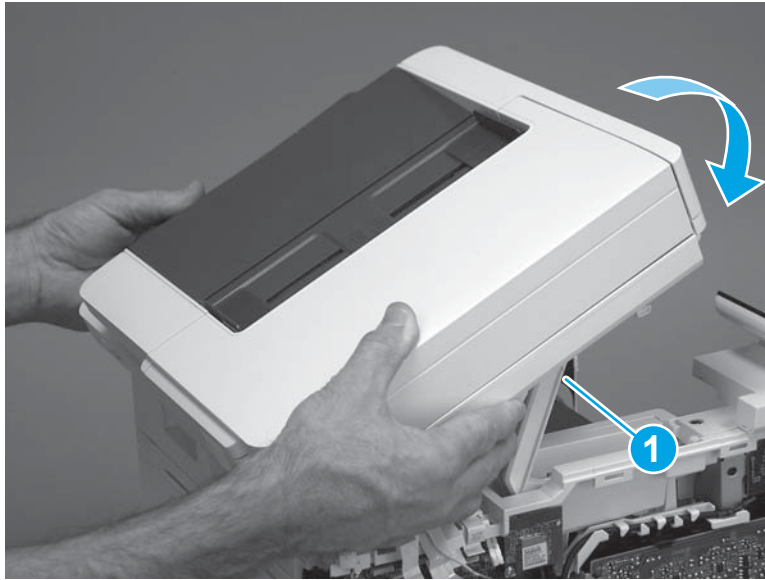

4. Pass the ground wire through the opening in the top cover.

Figure 1-266 Pass the wire through the opening

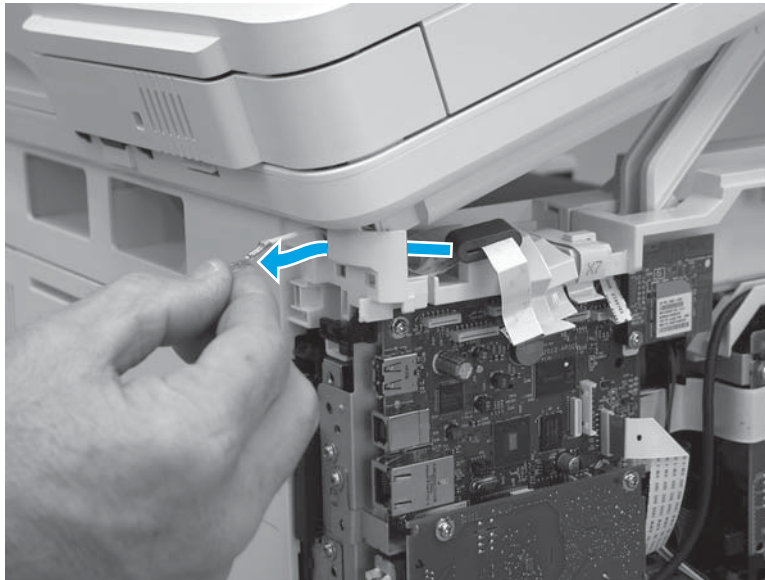

5. Install one screw (callout 1).

Figure 1-267 Install one screw

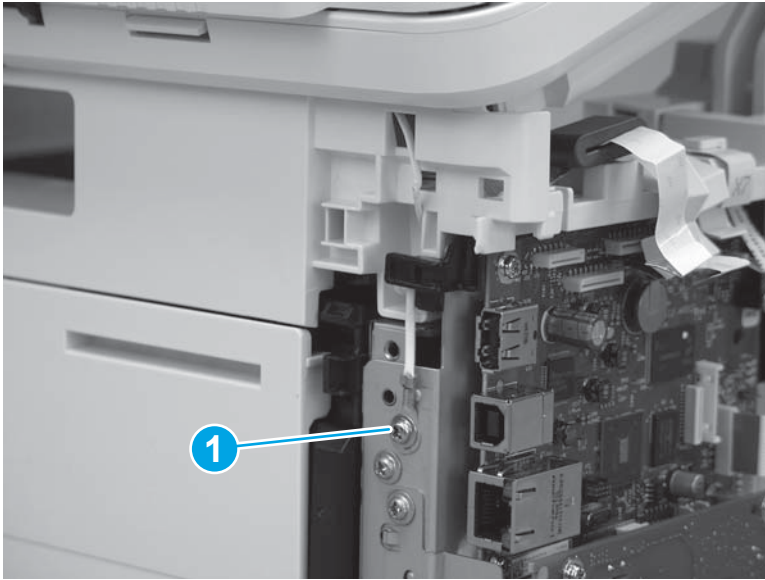

6. Install the ISA lift assembly slider pin.

 **Reinstallation tip:** Align the keyed portion of the locking pin with the slot and hole in the support arm.

Figure 1-268 Install the slider pin



7. Rotate the slider pin (callout 1) towards the rear of the printer until the tab (callout 2) snap into place.

Figure 1-269 Secure the slider pin

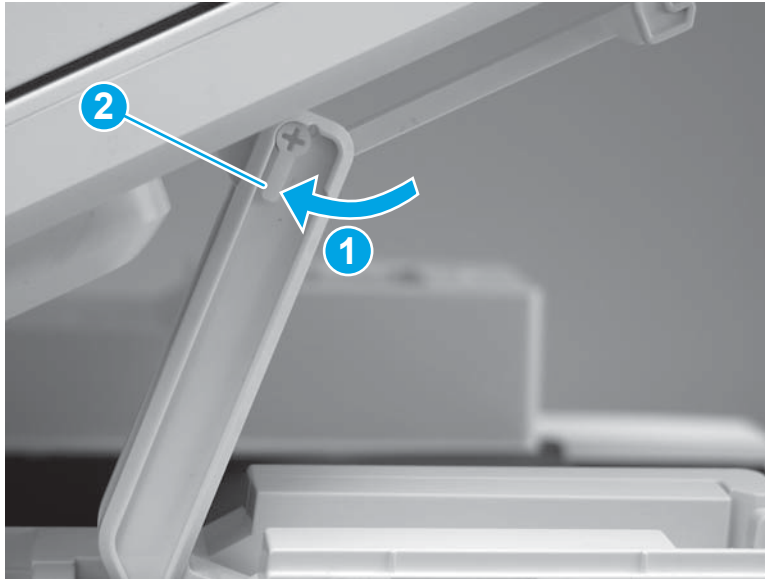

8. Install the ferrite (callout 1) in the holder, and then connect three FFCs (callout 2).

Figure 1-270 Connect three FFCs

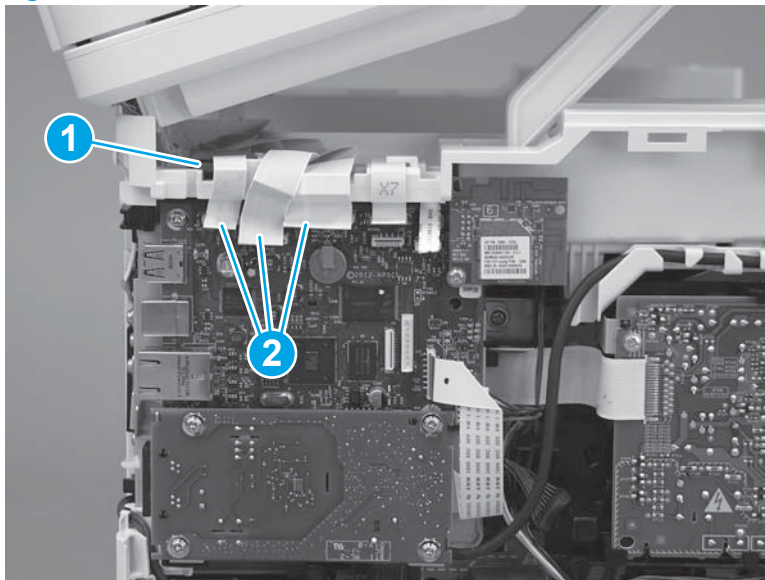

9. Position the rear edge of the ISA flat-flexible cable (FFC) cover on the printer (callout 1) , and then rotate it down (callout 2) until it snaps into place.

Figure 1-271 Install the ISA FFC cover

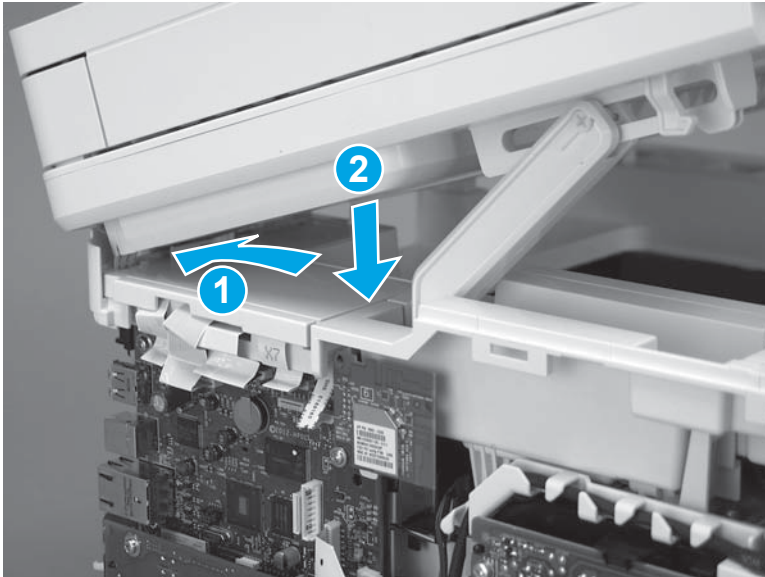

10. Lower the ISA.

Figure 1-272 Lower the ISA

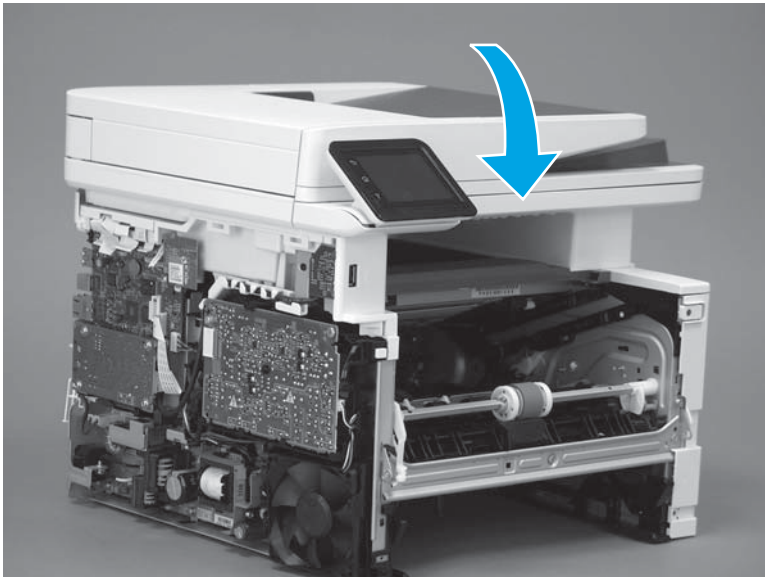

Step 14: Install the right cover

1. Position the cover (callout 1) on the printer, and then engage two bosses (callout 2).

Figure 1-273 Install the cover

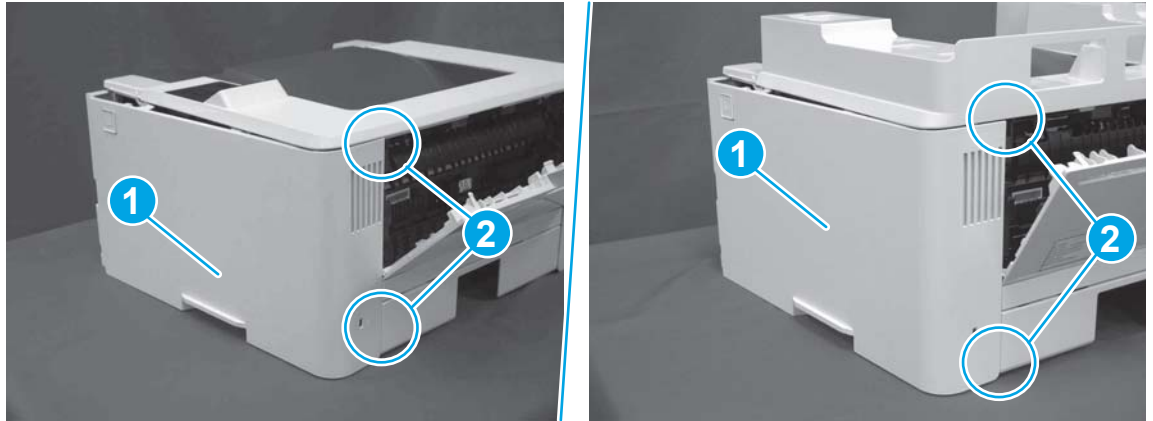

2. Rotate the front of the cover onto the printer (callout 1), engage three (callout 2) tabs, and then engage two bosses (callout 3).

Figure 1-274 Engage two bosses and one tab

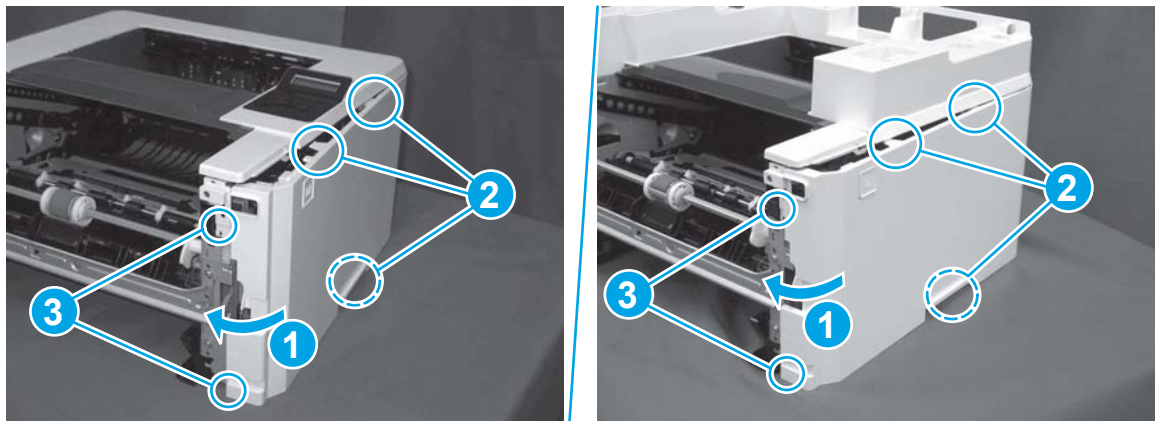

3. Make sure that the power switch (callout 1) and cartridge door assembly button (callout 2) correctly function.



NOTE: Remove, and then reinstall the cover if the switch or button does not correctly function.

Figure 1-275 Check the power switch and cartridge door assembly button

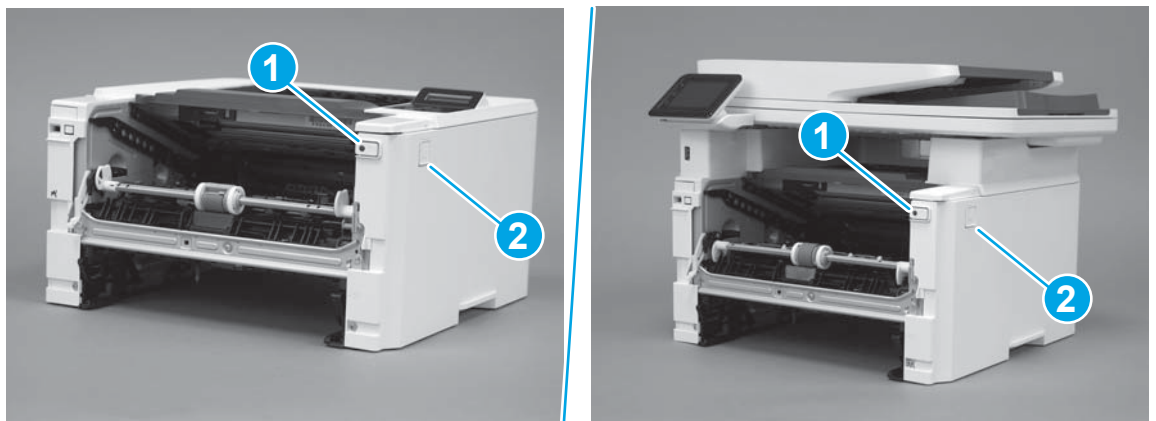

4. Install one screw (callout 1).

Figure 1-276 Install one screw



Step 15: Install the left cover

1. At the front of the printer, do one of the following:
 - **M403/M402:** Position the cover on the printer (callout 1), and then engage two bosses (callout 2).
 - **M427/M426:** Position the cover on the printer (callout 3), engage one tab (callout 4), and then engage two bosses (callout 4).

Figure 1-277 Install the cover

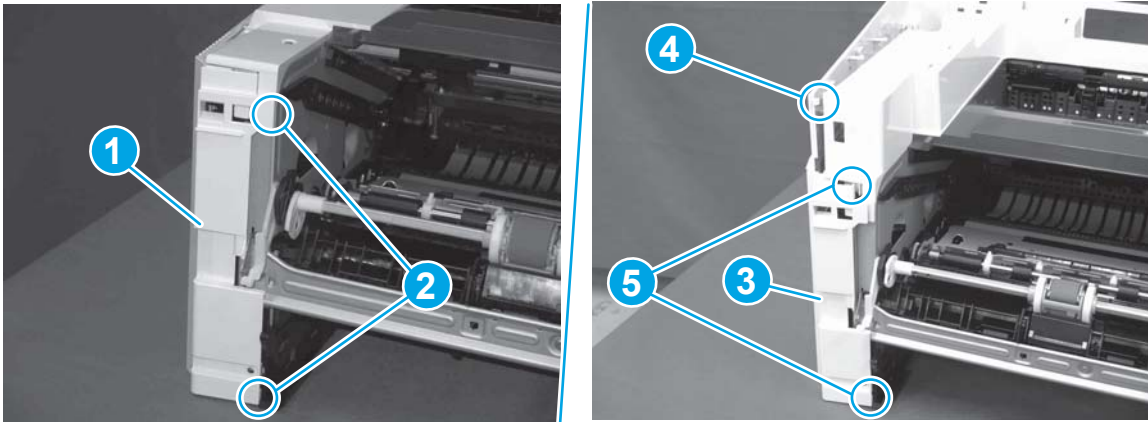

- Carefully rotate the rear of the cover onto the printer (callout 1), engage three tabs (callout 2), and then engage two bosses (callout 3).

Figure 1-278 Engage three tabs and two bosses

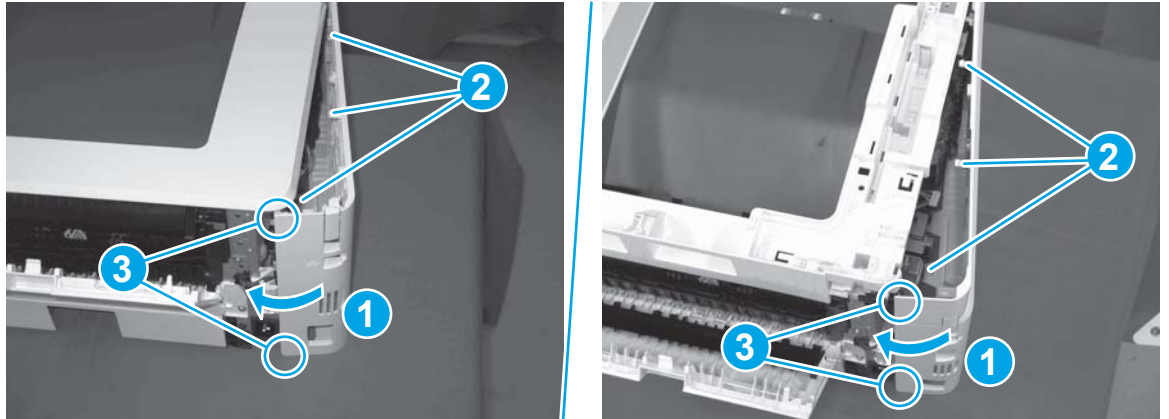

- Install one screw (callout 1).

Figure 1-279 Install one screw

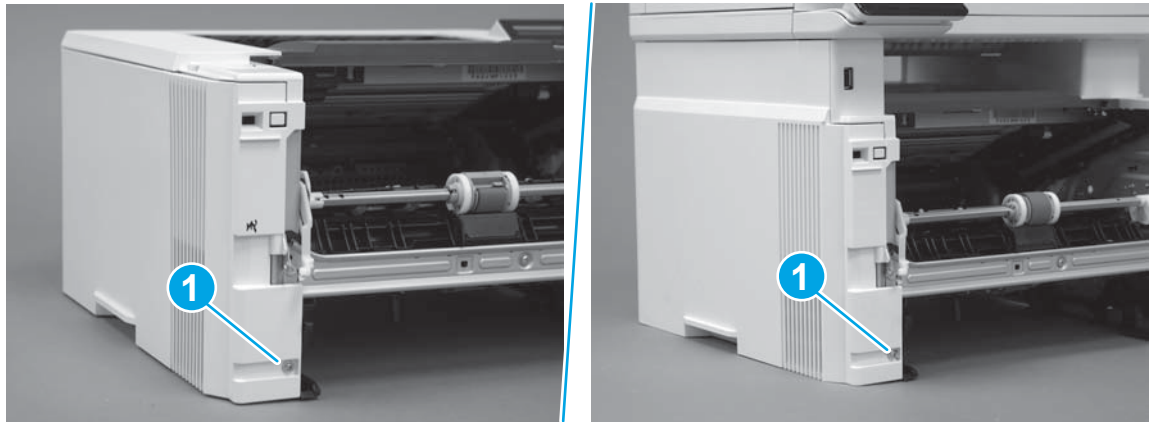

Step 16: Install the cartridge door assembly

 **Reinstallation tip:** After a replacement door is installed, make sure to install the nameplate (supplied in the kit) corresponding to the printer name on the door.

- Position the door close to the printer, and then engage the keyed pin on the left-side retainer arm with the hole in the door.

Figure 1-280 Engage the left-side retainer arm

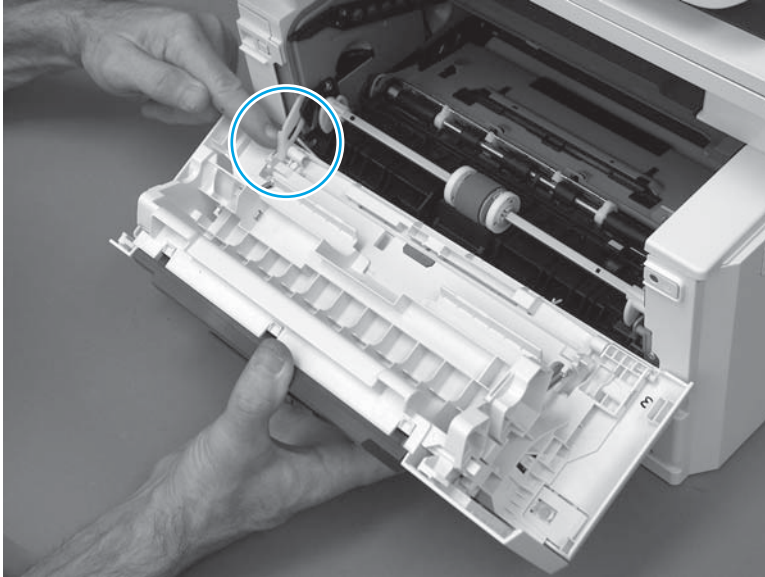

2. Engage the right-side door hinge pin with the hole in the chassis (callout 1).

Figure 1-281 Install the door

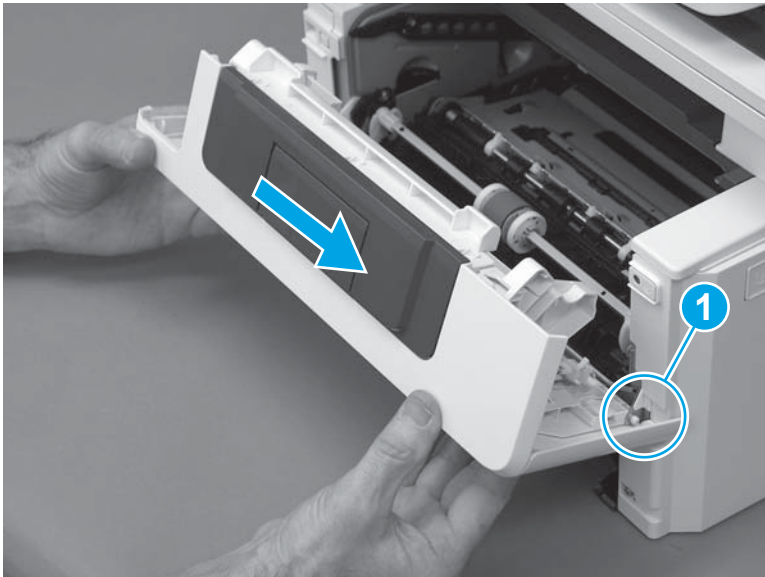

3. Install the link (callout 1).

 **IMPORTANT:** Make sure that the link snaps into place on the arm (callout 2). The link actuates the fuser pressure-release mechanism.

Figure 1-282 Install the pressure-release link

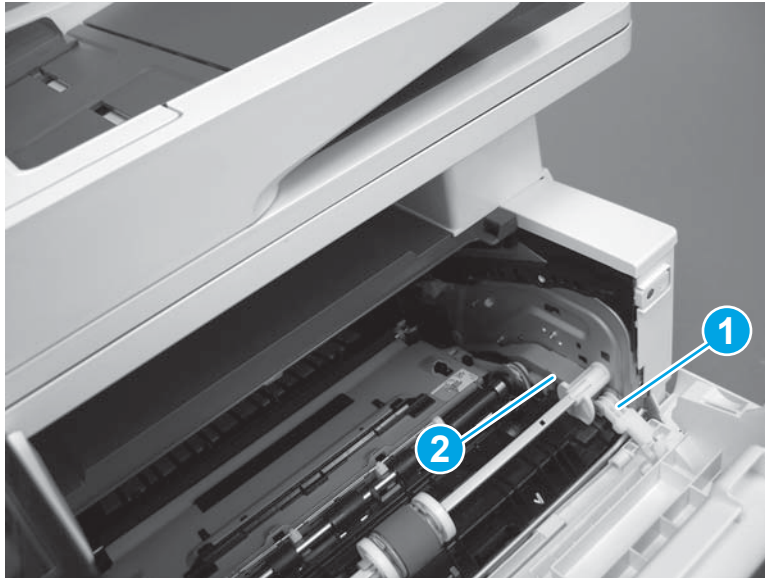

4. Slide the guide into the printer (callout 1), and then make sure that the tab (callout 2) snaps into place to secure the guide to the chassis.

Figure 1-283 Install the guide

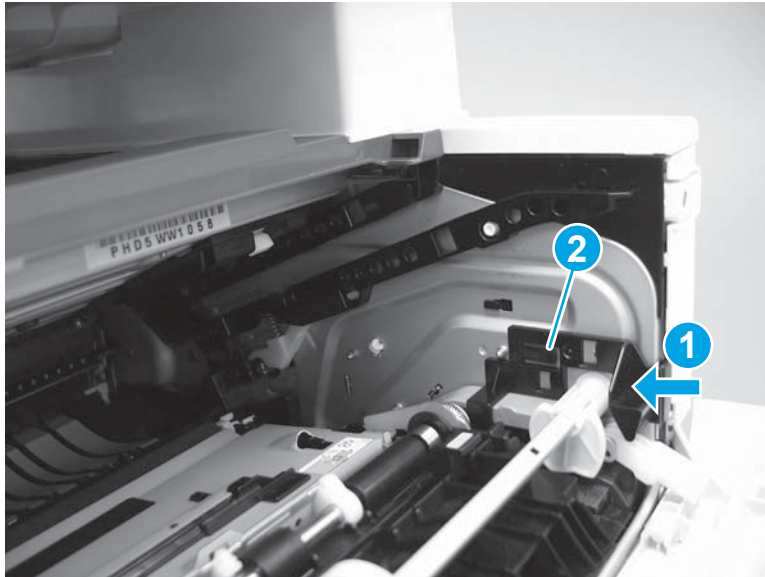

5. Position the shaft on the door, and then align the left-side hinge on the door with the hole in the chassis (callout 1).

Figure 1-284 Align the hinge

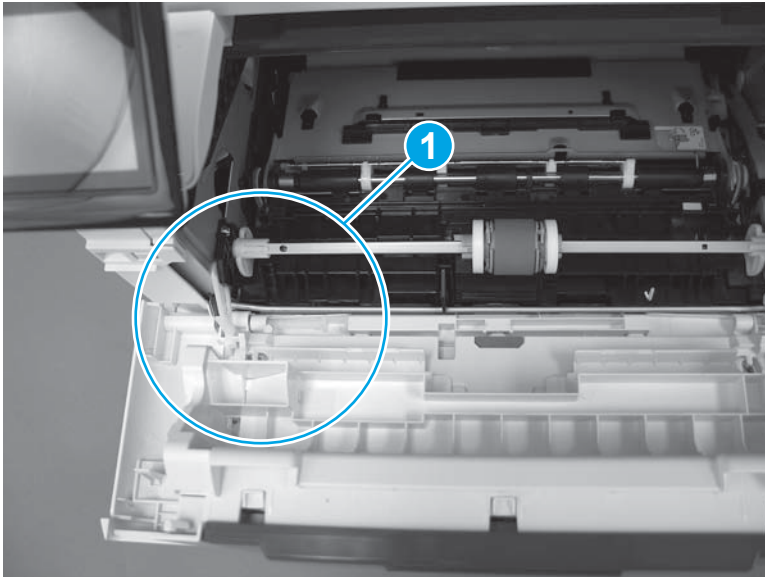

6. Push the shaft towards the left side of the printer to install it (callout 1).

 **Reinstallation tip:** Make sure that the support shaft is fully installed and correctly orientated (callout 2) so that it will not interfere with the door opening and closing.

Figure 1-285 Install the support shaft



Step 17: Install Tray 2

- ▲ Slide the tray straight into the printer to install it.

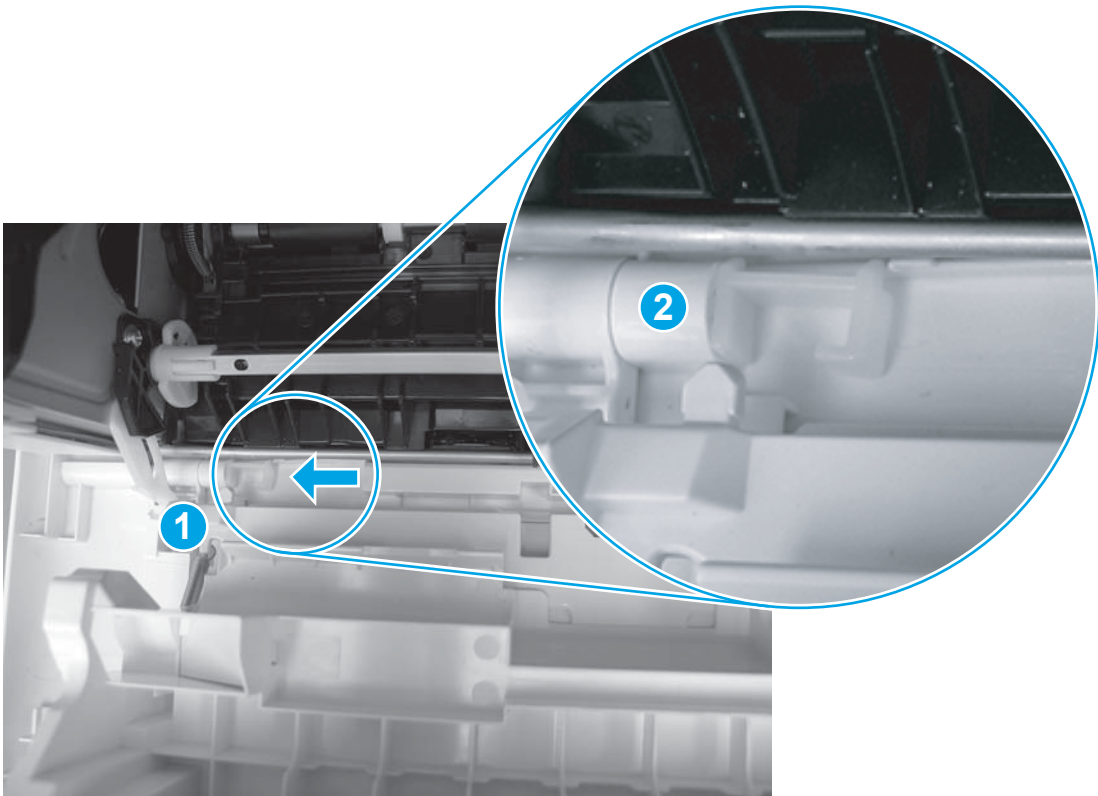
Figure 1-286 Install the tray



Removal and replacement: Cable guide (M427/M426)

- [Introduction](#)
- [Step 1: Remove Tray 2](#)
- [Step 2: Remove the cartridge door assembly](#)
- [Step 3: Remove the left cover](#)
- [Step 4: Remove the right cover](#)
- [Step 5: Remove the control panel \(M427/M426\)](#)
- [Step 6: Remove the integrated scanner assembly \(M427/M246\)](#)
- [Step 7: Remove the top cover \(M427/M426\)](#)
- [Step 8: Remove the cable guide \(M427/M426\)](#)
- [Step 9: Unpack the replacement assembly](#)
- [Step 10: Install the cable guide \(M427/M426\)](#)
- [Step 11: install the top cover \(M427/M426\)](#)
- [Step 12: Install the integrated scanner assembly \(M427/M246\)](#)
- [Step 13: Install the control panel \(M427/M426\)](#)
- [Step 14: Install the right cover](#)
- [Step 15: Install the left cover](#)
- [Step 16: Install the cartridge door assembly](#)
- [Step 17: Install Tray 2](#)

Introduction

This document provides the procedures to remove and replace the cable guide (M427/M426).

Before performing service

Turn the printer power off

- Disconnect the power cable.

 **WARNING!** To avoid damage to the printer, turn the printer off, wait 30 seconds, and then remove the power cable before attempting to service the printer.

Use the table below to identify the correct part number for your printer. To order the part, go to www.hp.com/buy/parts.

Cable guide (M427/M426) part number

RC4-3217-000CN

Cable guide (M427/M426)

Required tools

- #2 Phillips screwdriver with a magnetic tip.
- Small flat-blade screw driver

After performing service

Turn the printer power on

- Connect the power cable.
- Use the power switch to turn the power on.

Post service test

Make sure that the printer initializes to a **Ready** state.

Print a configuration page to make sure that the printer is functioning correctly.

Step 1: Remove Tray 2

- ▲ Pull the tray straight out of the printer to remove it.

Figure 1-287 Remove the tray



Step 2: Remove the cartridge door assembly



NOTE: If the toner cartridge was not removed prior to servicing the printer, remove it now.

1. Release one tab (callout 1), and then slide shaft (callout 2) in the direction the arrow indicates and remove it.



TIP: It might be easier to release the support shaft by using a small flat-blade screwdriver.

Figure 1-288 Release the support shaft

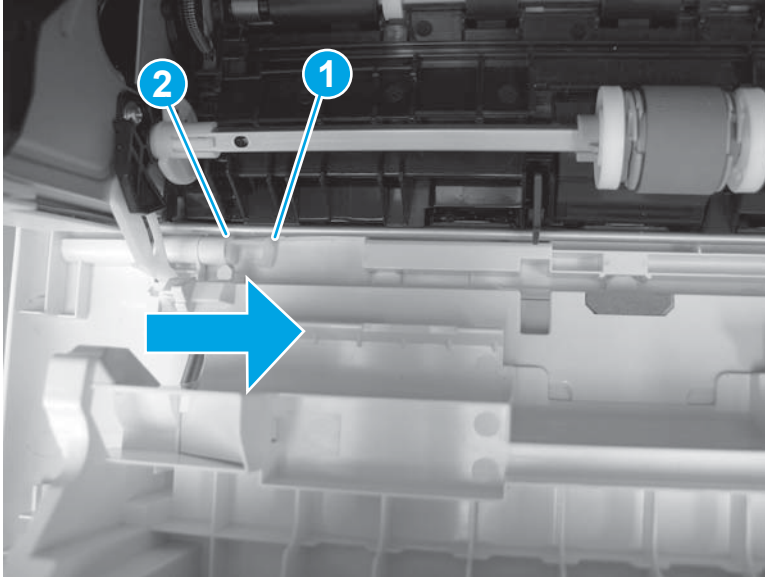

2. Release one tab (callout 1), and then slide the guide (callout 2) in the direction the arrow indicates and remove it.

Figure 1-289 Remove the guide

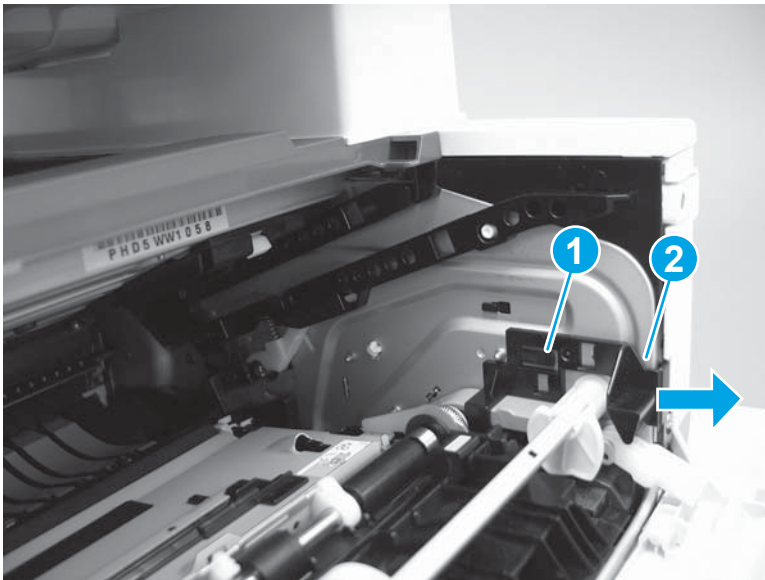

3. Remove the link arm (callout 1).

Figure 1-290 Remove the link arm

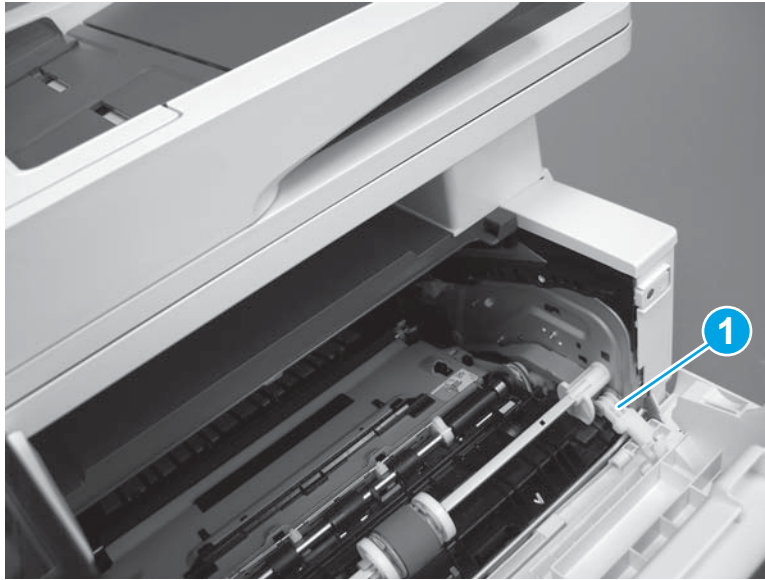

4. Slide the cartridge door assembly (callout 1) in the direction the arrow indicates and remove it.

Figure 1-291 Remove the door

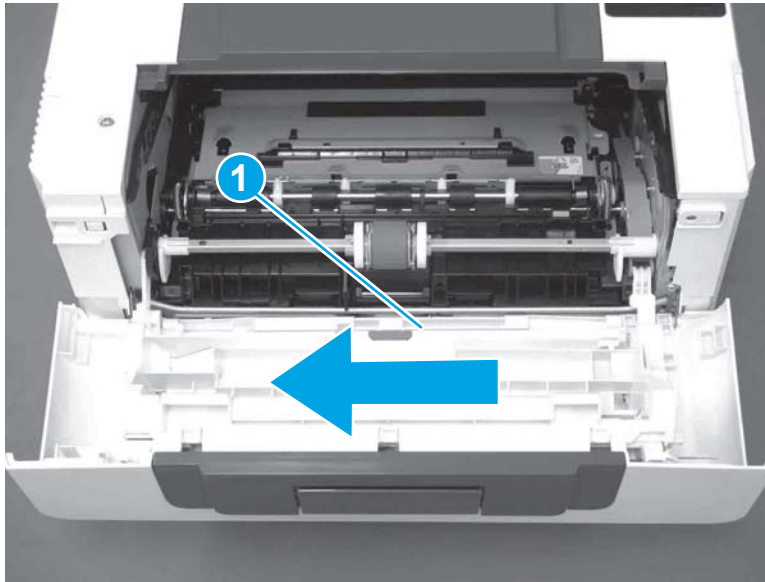

5. Remove the link (callout 1) from the cartridge door assembly (callout 2).

Figure 1-292 Release the left-side retainer arm

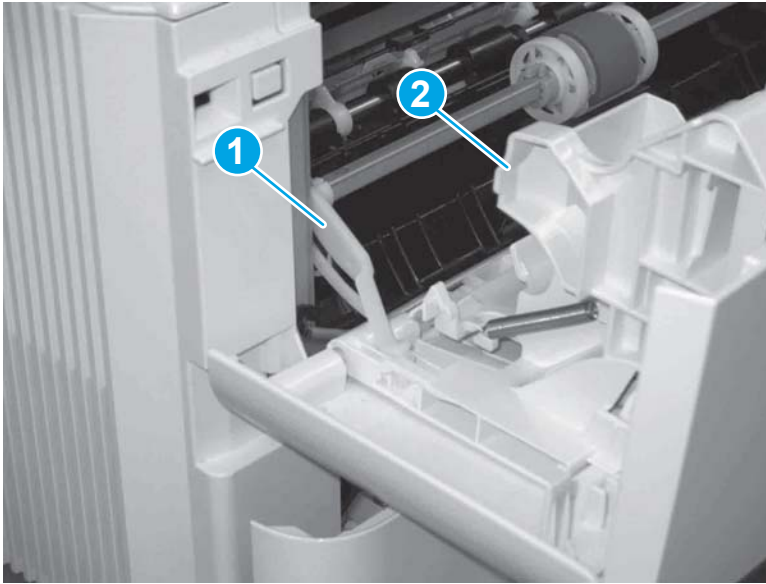

Step 3: Remove the left cover

1. Remove one screw (callout 1).

Figure 1-293 Remove one screw

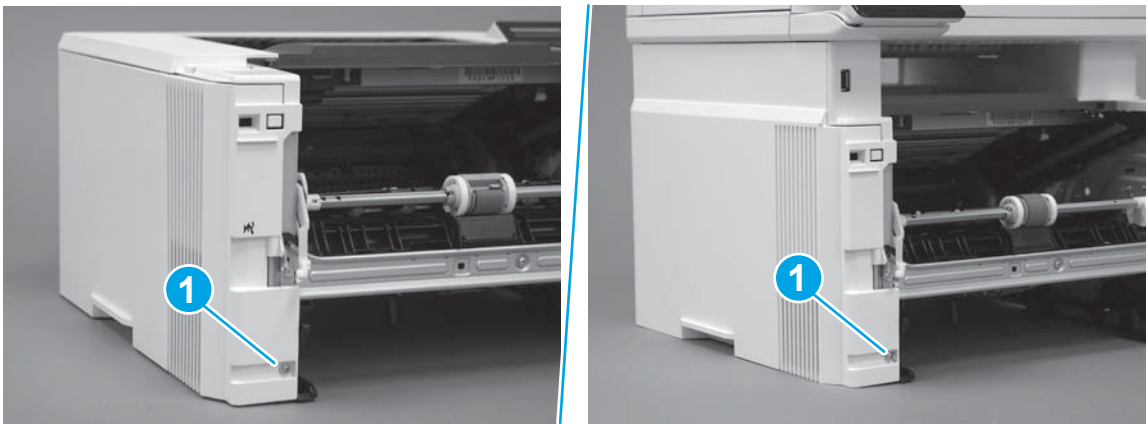

2. Open the rear door, release two bosses (callout 1), and then release three tabs (callout 2).

Figure 1-294 Release two bosses and three tabs

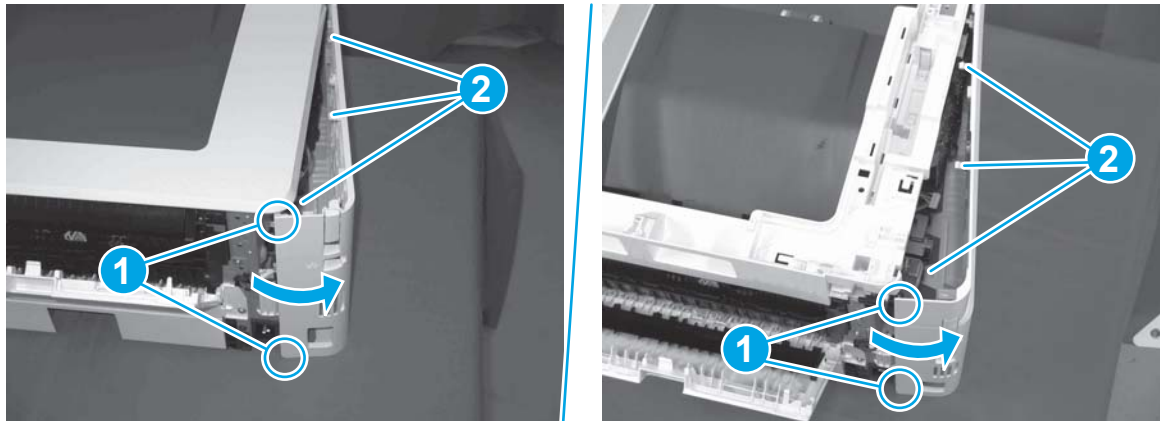

3. At the front of the printer, do one of the following:
 - **M403/M402:** Release two bosses (callout 1), and then remove the cover (callout 2).
 - **M427/M426:** Release one tab (callout 3), two bosses (callout 4), and then remove the cover (callout 5).

CAUTION: Be careful when releasing the upper bosses on the M427/M426 cover. One portion of the cover (callout 6) is fragile and is easily broken.

Figure 1-295 Remove the cover

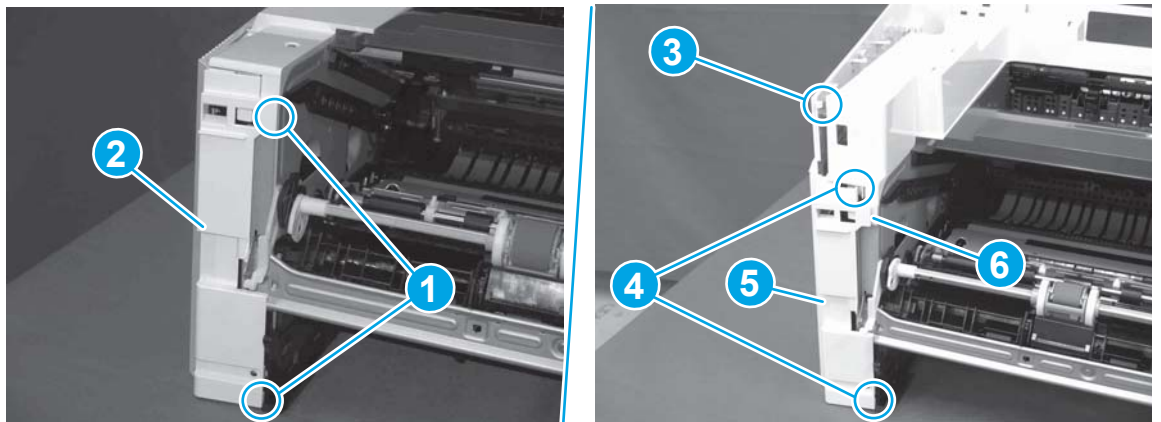

Step 4: Remove the right cover

1. Remove one screw (callout 1).

Figure 1-296 Remove one screw



2. At the front of the printer, release two bosses (callout 1), and then release three tabs (callout 2).

Figure 1-297 Release two bosses and three tabs

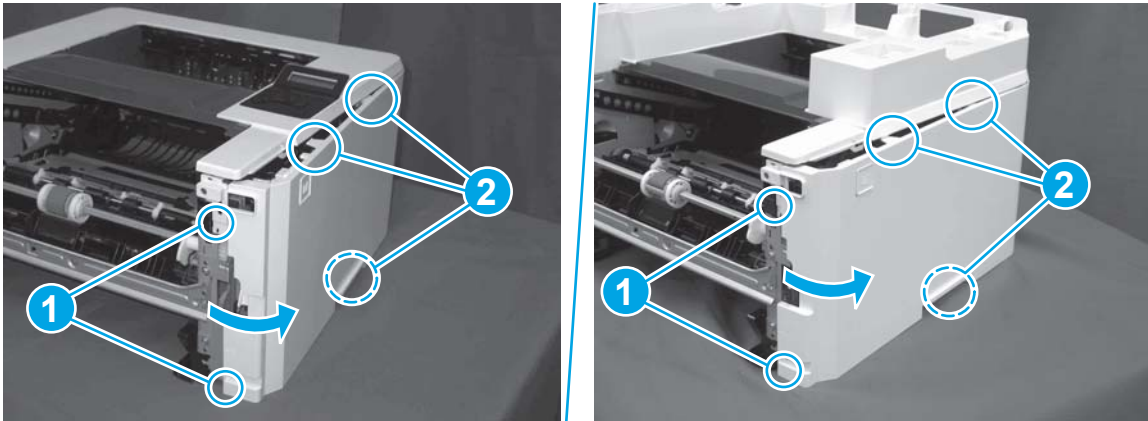

3. Open the rear door, release two bosses (callout 1), and then remove the cover (callout 2).

Figure 1-298 Remove the cover

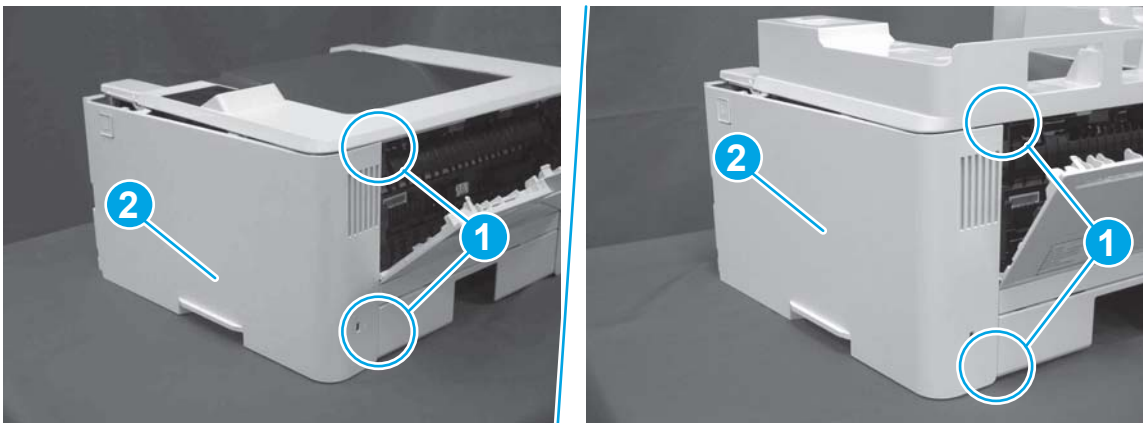

Step 5: Remove the control panel (M427/M426)

1. Disconnect one FFC (callout 1; J114), and then release the FFC from the retainer (callout 2).

Figure 1-299 Disconnect one connector

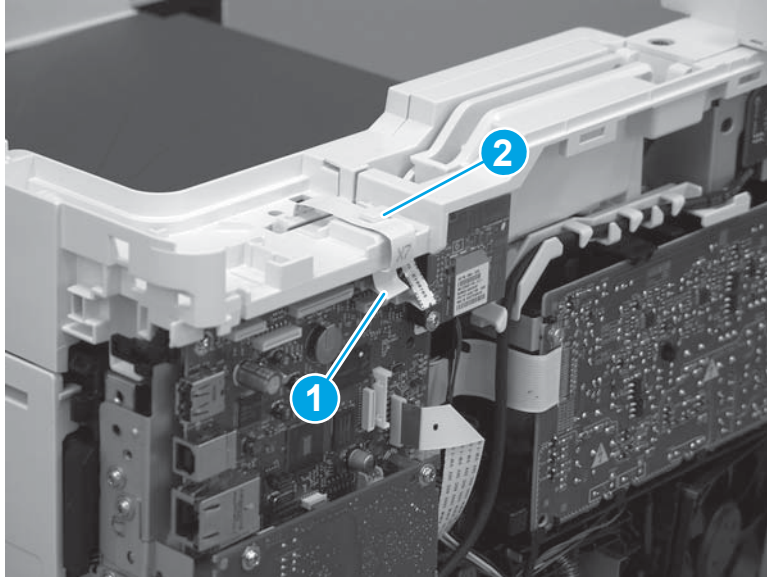

2. Remove one screw (callout 1).

Figure 1-300 Remove one screw

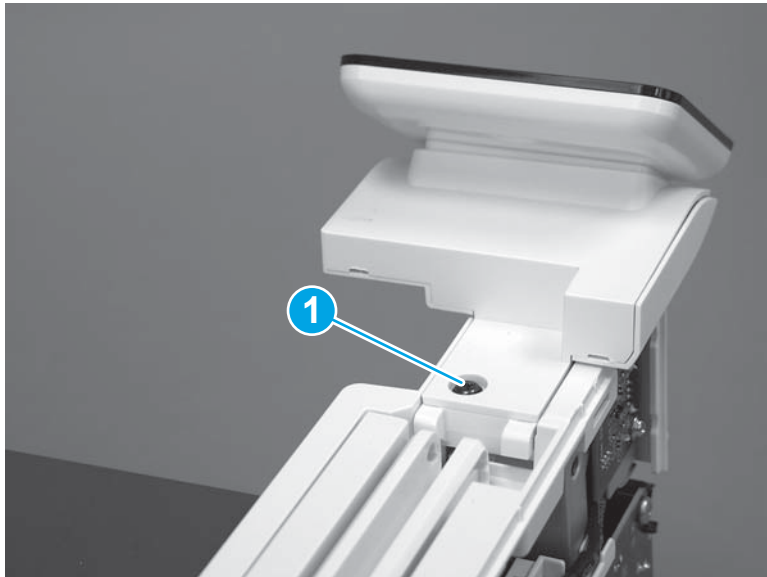

3. Use a small flat-blade screwdriver to release two tabs (callout 1) on the control-panel cable cover.

Figure 1-301 Release two tabs

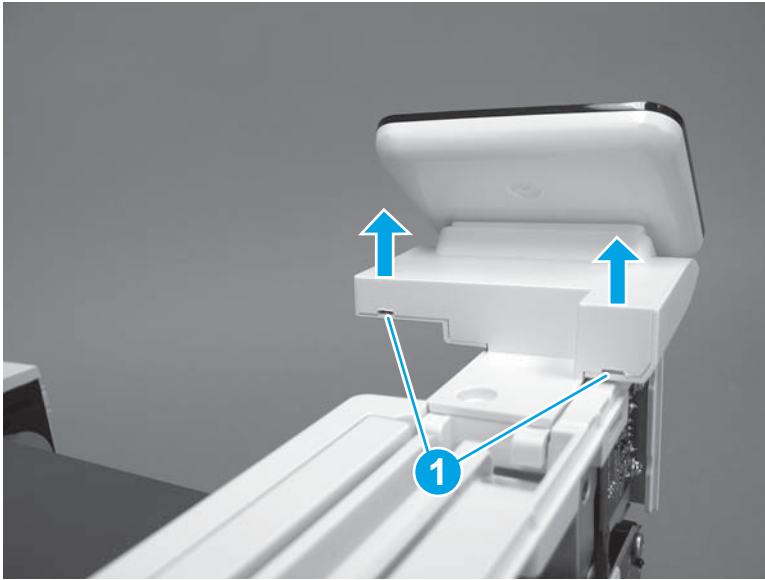

4. Remove the control-panel cable cover.

Figure 1-302 Remove the cover

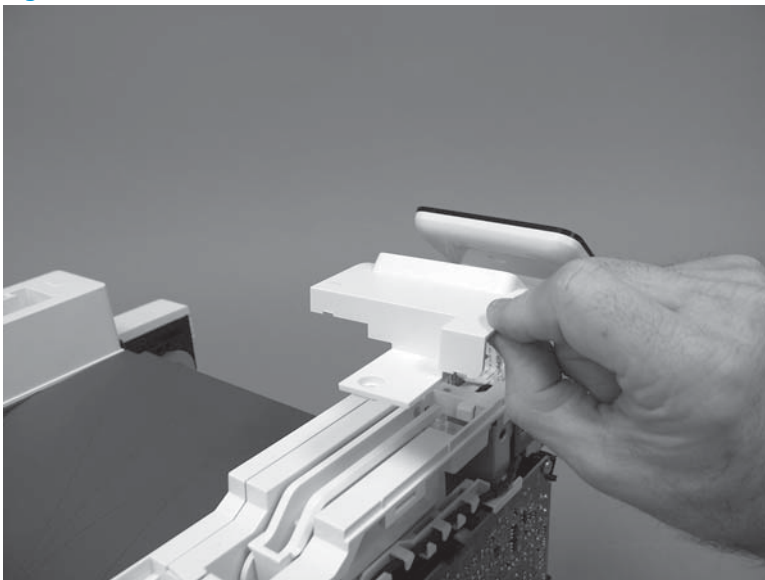

5. Remove one grounding screw (callout 1), and then move the ground cable (callout 2) out of the way.

Figure 1-303 Remove one screw

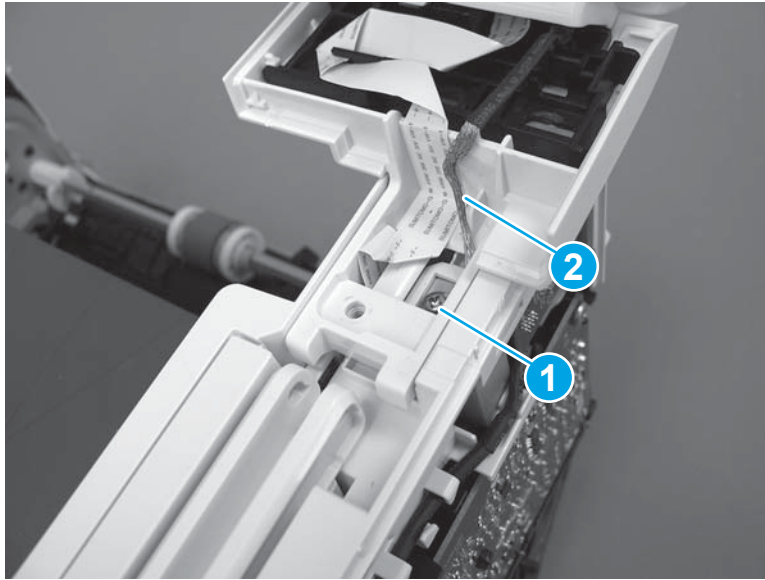

6. Move the FFC out of the way, and then remove two screws (callout 1).

Figure 1-304 Remove two screws

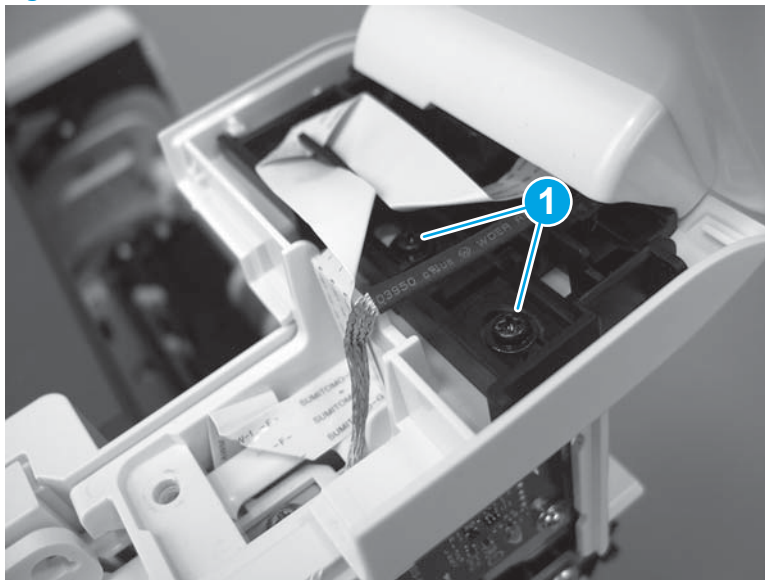

7. Slightly lift up the control-panel assembly to separate it from the top cover.

⚠ CAUTION: The control panel assembly is still connected to the printer by the FFC. Do not attempt to completely remove the assembly.

Figure 1-305 Lift up the control-panel assembly

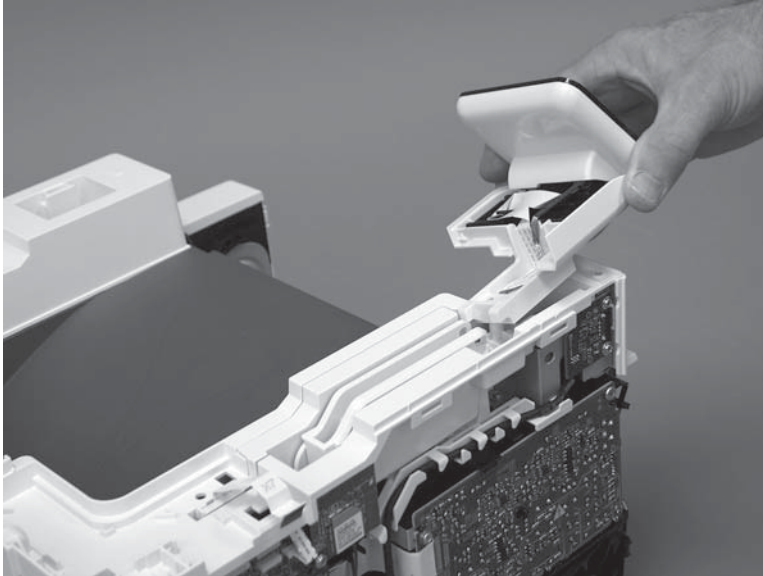

8. Lift up the control-panel FFC cover to remove the control-panel assembly.

Figure 1-306 Remove the control-panel assembly

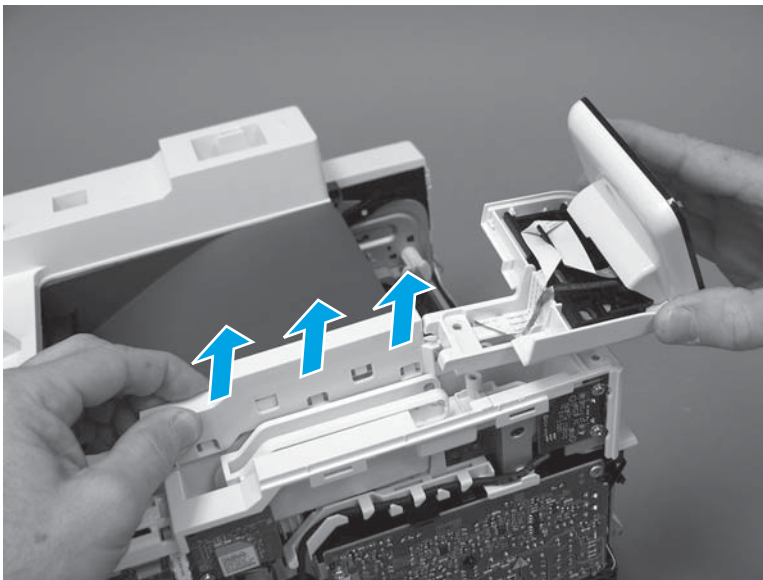

Step 6: Remove the integrated scanner assembly (M427/M246)

📄 NOTE: M427/M426 models only. The integrated scanner assembly (ISA) includes the sub-scanner assembly (SSA) and the automatic document feeder (ADF).

1. Raise the ISA.

Figure 1-307 Raise the ISA

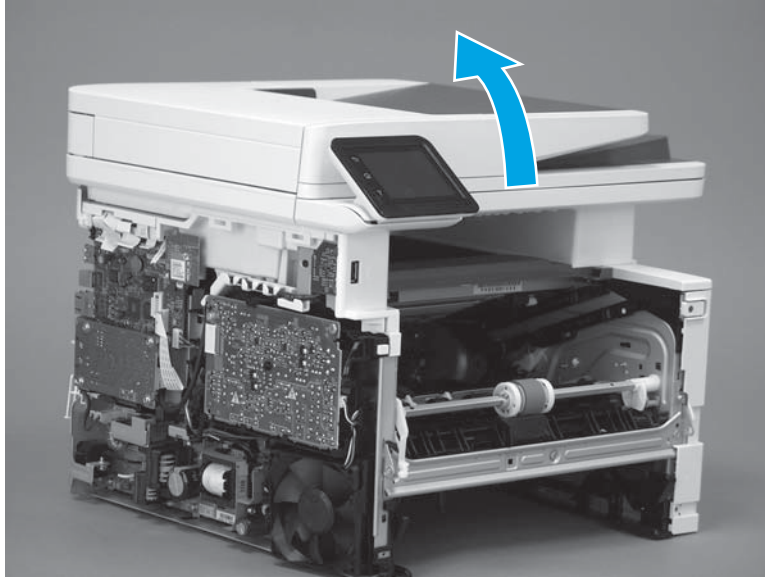

2. Release the ISA flat-flexible cable (FFC) cover (callout 1), and then remove it (callout 2).

Figure 1-308 Remove the ISA FFC cover

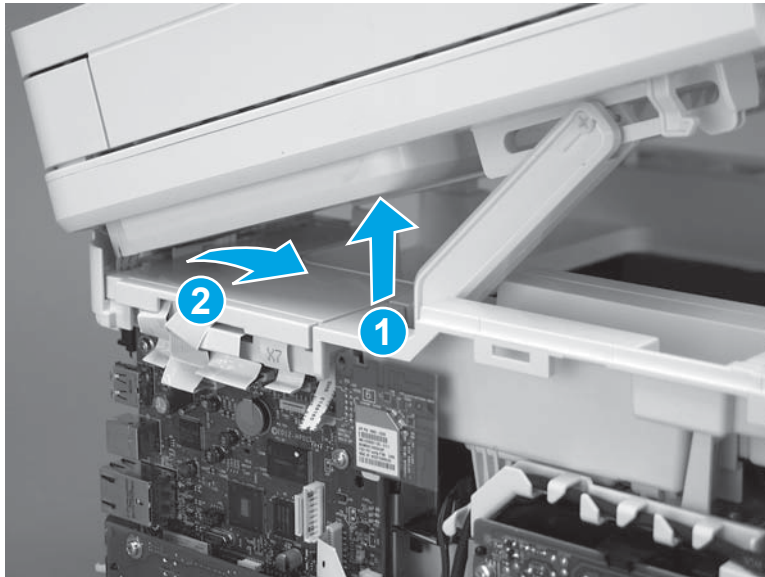

3. Disconnect three FFCs (callout 1), and then remove the ferrite (callout 2) from the holder.

CAUTION: The ferrite is not captive on the FFC. Do not lose the ferrite while handling the ISA.

Figure 1-309 Disconnect three FFCs

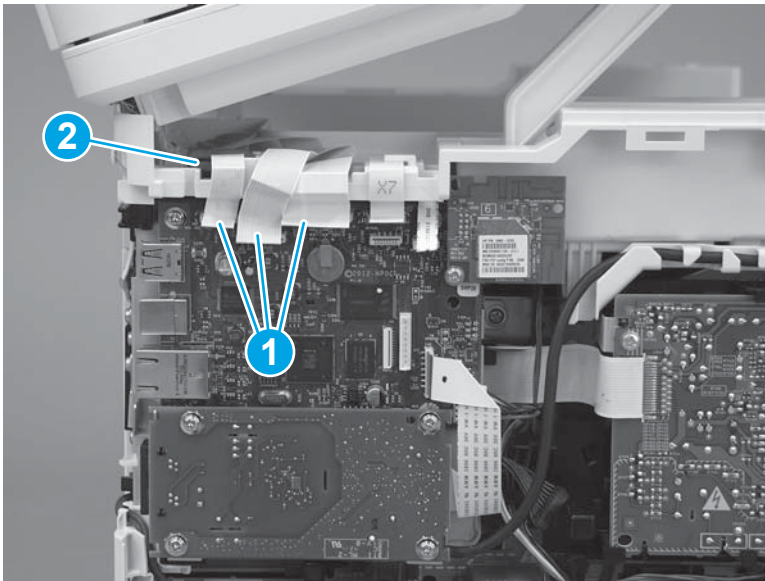

4. Remove one screw (callout 1).

Figure 1-310 Remove one screw

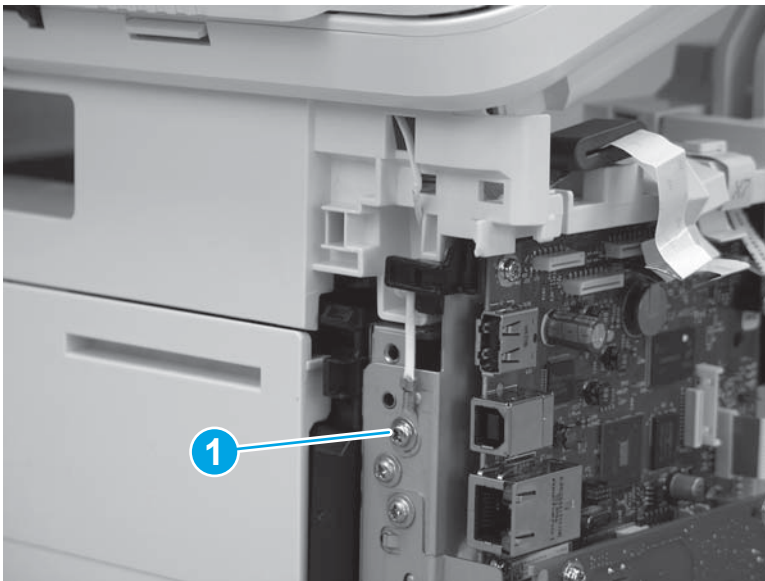

5. Pass the ground wire through the opening in the top cover.

Figure 1-311 Pass the wire through the opening

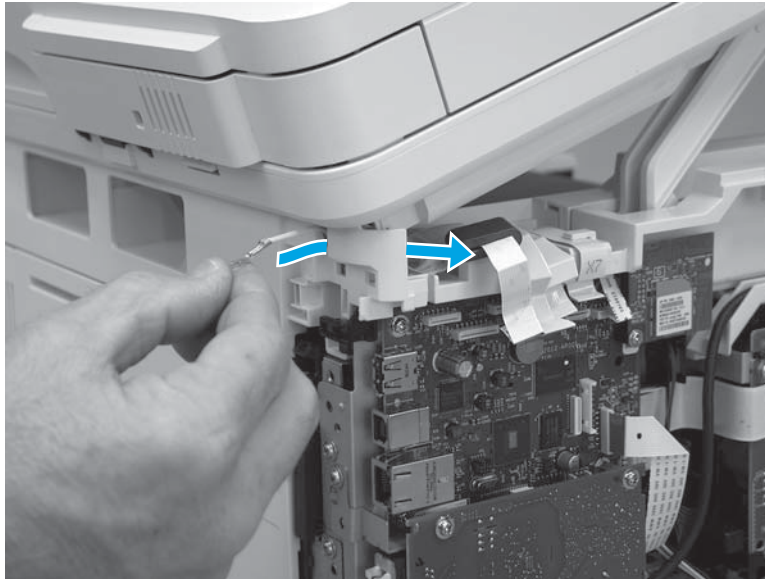

6. Release one tab (callout 1), and then rotate the ISA slider pin (callout 2) towards the front of the printer to release it.

Figure 1-312 Release one tab and rotate the slider pin

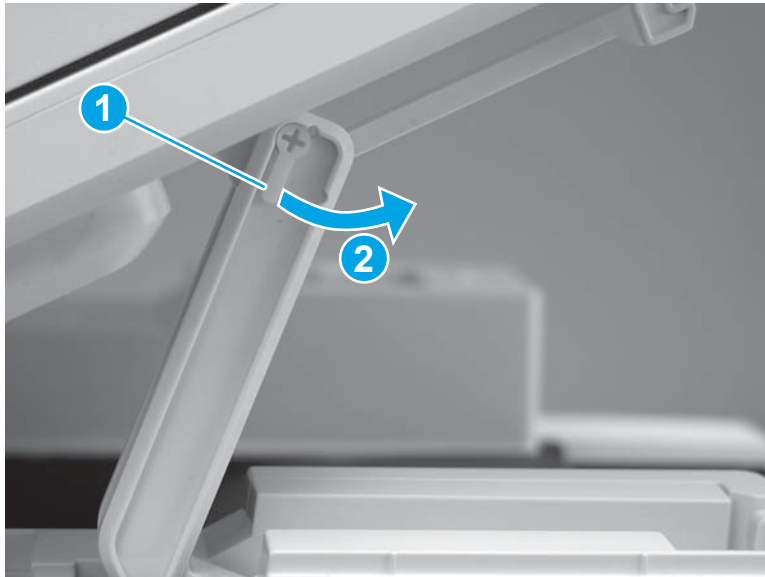

7. Remove the slider pin.

Figure 1-313 Remove the slider pin

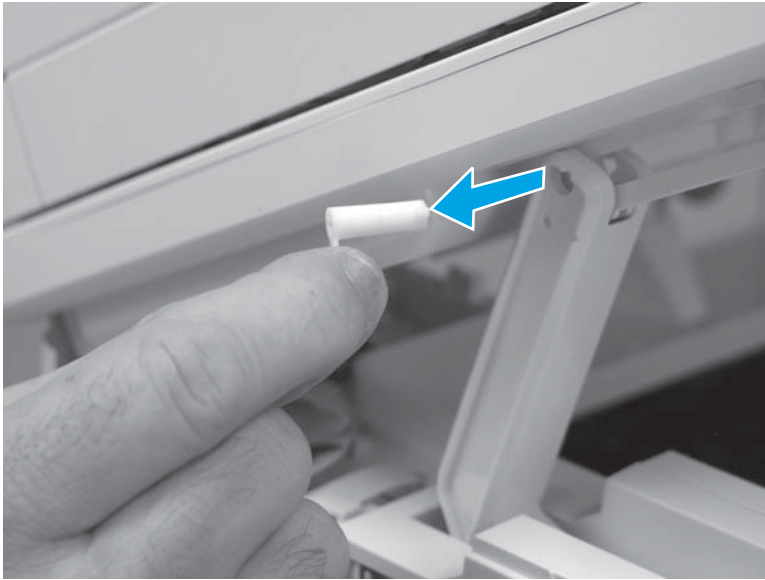

8. Rotate the ISA towards the rear of the printer until it stops.

Figure 1-314 Rotate the ISA towards the rear of the printer



9. Slide the ISA as shown to release it.

Figure 1-315 Release the ISA

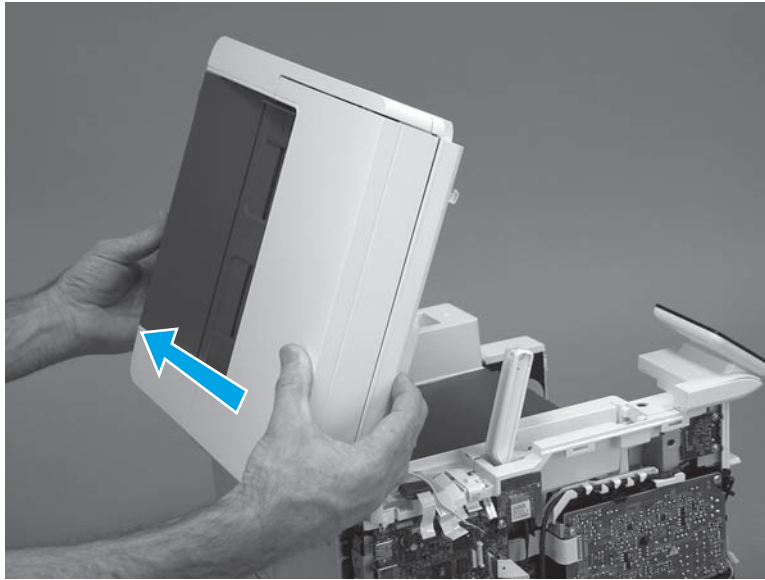

10. Remove the ISA.

Figure 1-316 Remove the ISA

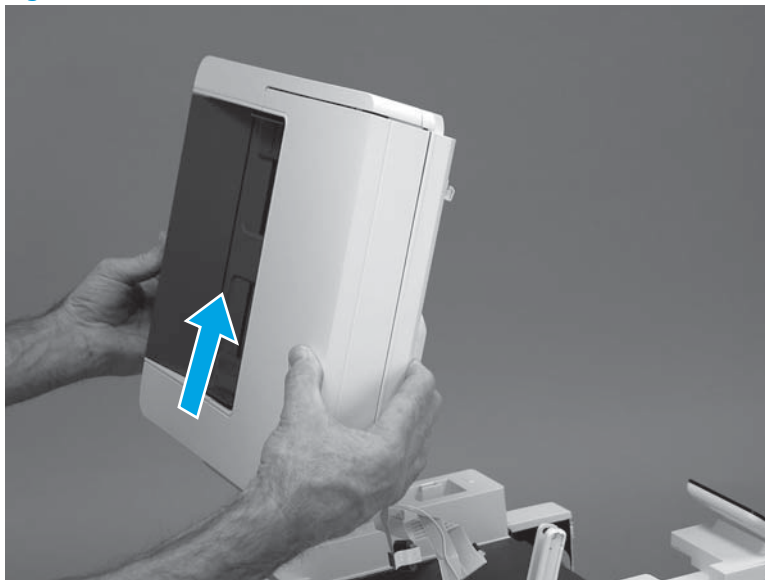

Step 7: Remove the top cover (M427/M426)

1. Release the USB cable (callout 1) from the cable guide.

Figure 1-317 Remove the USB cable

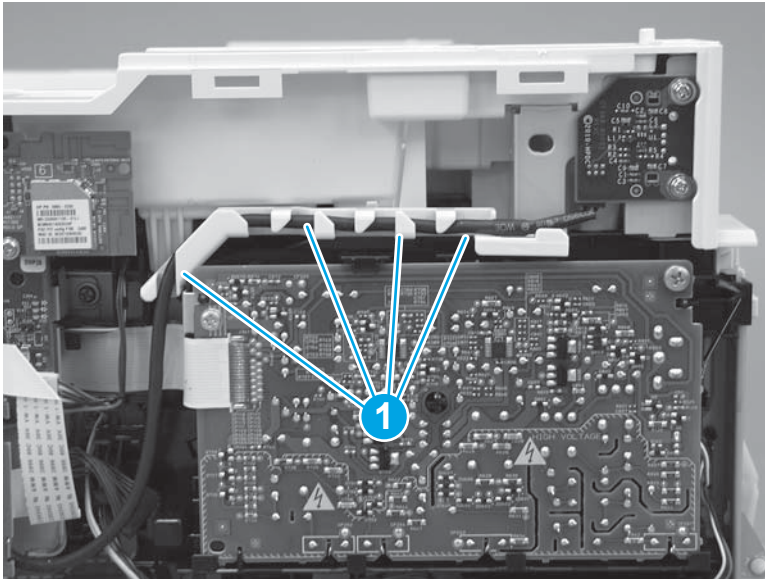

2. Remove five screws (callout 1), release four bosses (callout 2), and then remove the top cover (callout 3).

Figure 1-318 Remove the cover

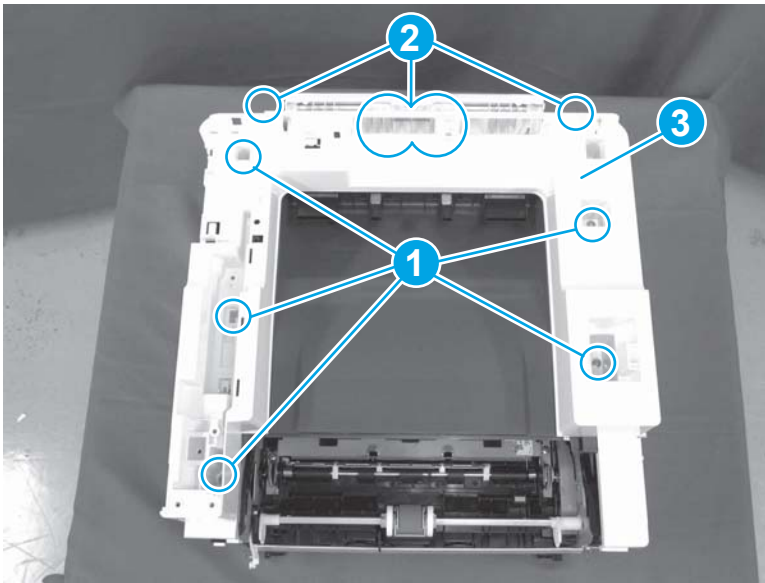

Step 8: Remove the cable guide (M427/M426)

1. Turn the top cover over, and then release one tab (callout 1).

Figure 1-319 Release one tab

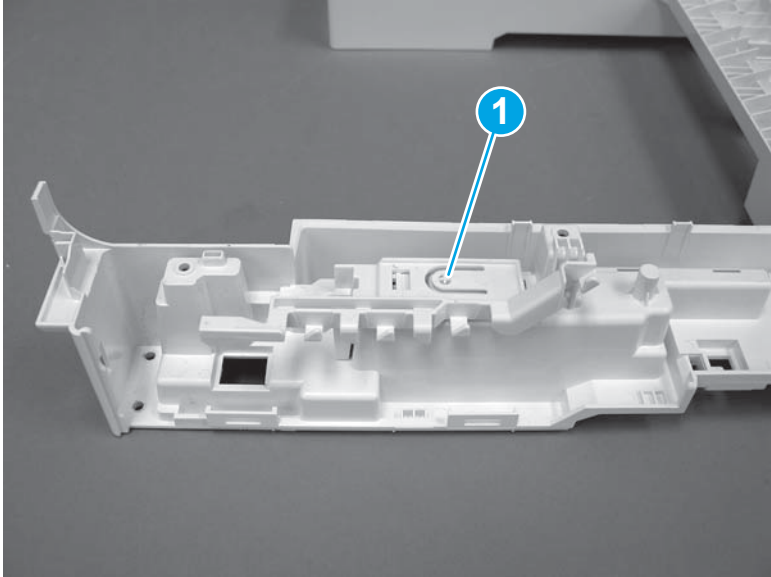

- 2. Slide the guide as shown to release it.

Figure 1-320 Release the guide

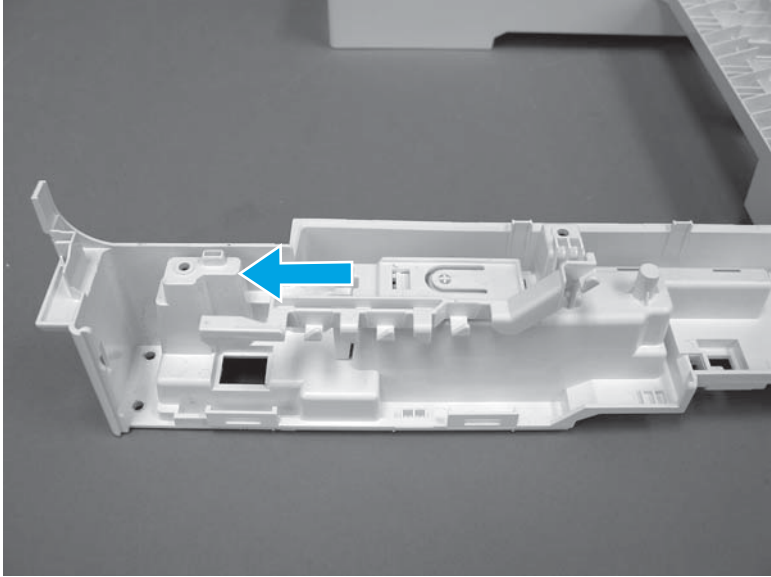

3. Remove the guide.

Figure 1-321 Remove the guide

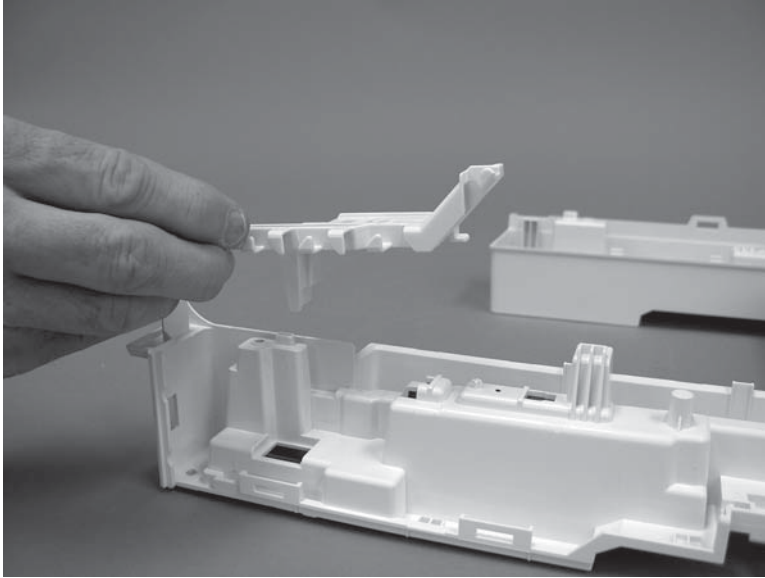

Step 9: Unpack the replacement assembly

Unpack the replacement part from the packaging.

<http://www8.hp.com/us/en/hp-information/environment/product-recycling.html>



NOTE: HP recommends responsible disposal of the defective part.

Figure 1-322 Recycle and unpack

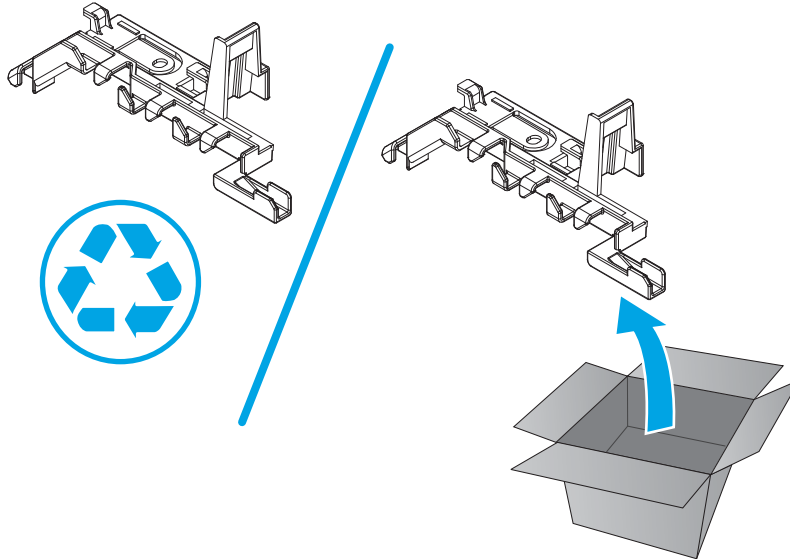

Step 10: Install the cable guide (M427/M426)

1. Position the guide on the printer with the two tabs (callout 1) in the slots (callout 2) in the chassis.

Figure 1-323 Position the guide on the printer

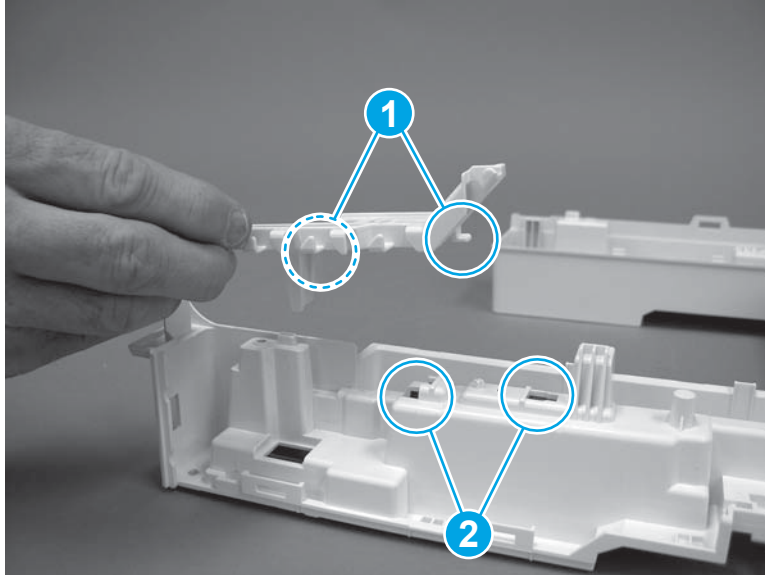

2. Slide the guide as shown (callout 1) to install it.

Figure 1-324 Install the guide

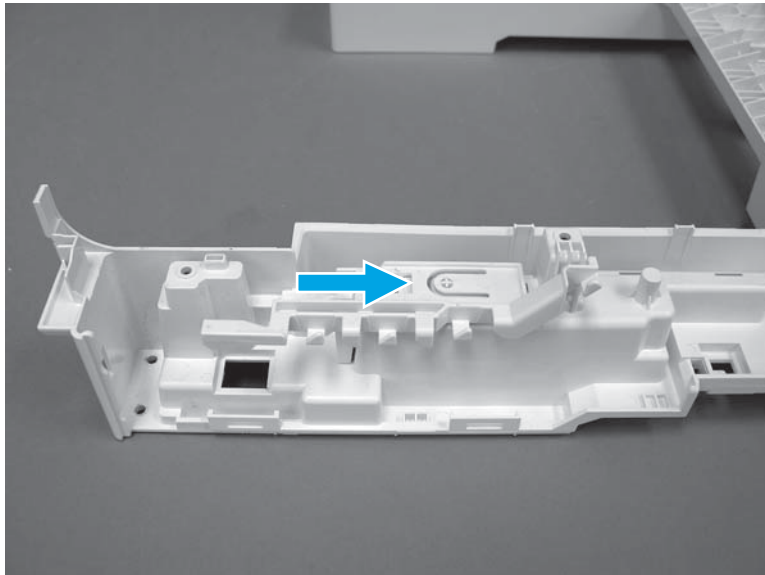

3. Make sure that the tab (callout 1) snaps into place.

Figure 1-325 Check the guide

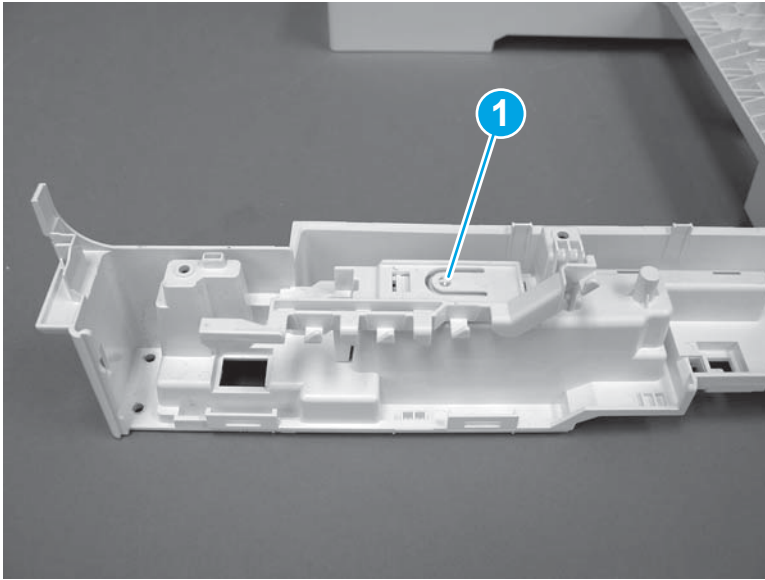

Step 11: install the top cover (M427/M426)

1. Position the rear edge of the top cover on the printer.

Figure 1-326 Install the cover

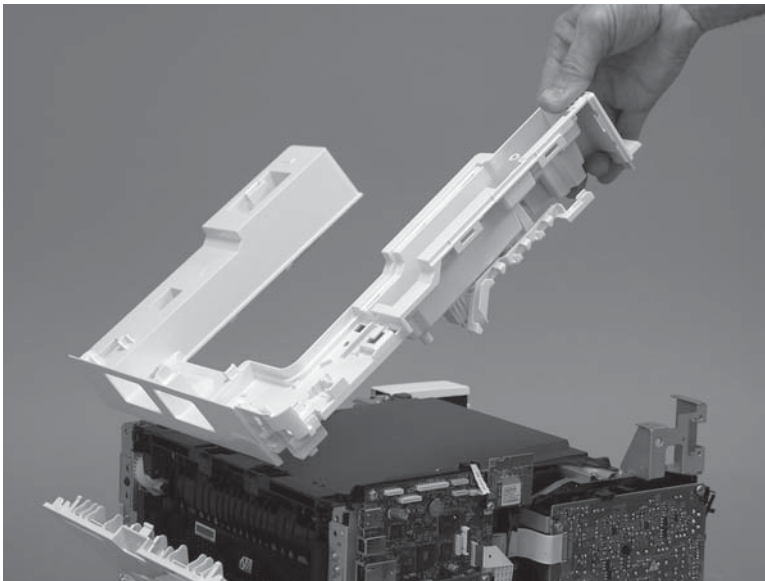

2. Engage four bosses (callout 1).

Figure 1-327 Engage four bosses

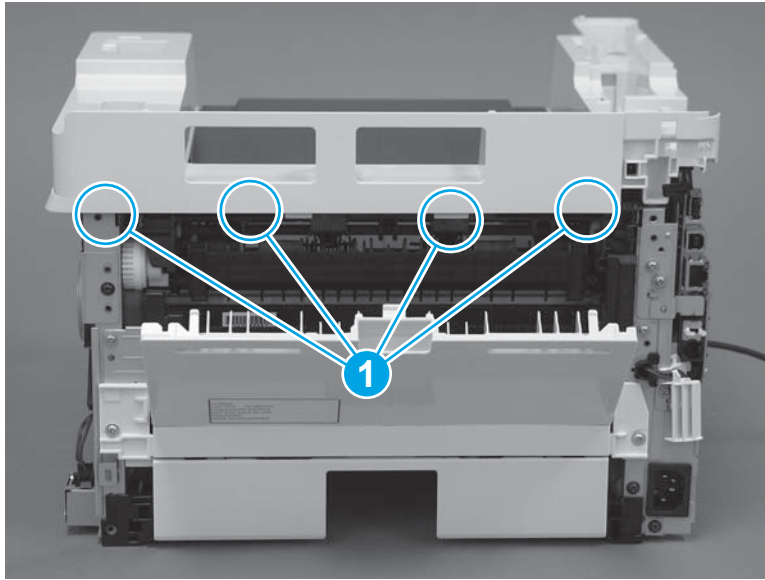

3. Rotate the front edge of the cover down.

Figure 1-328 Rotate the front edge of the cover down

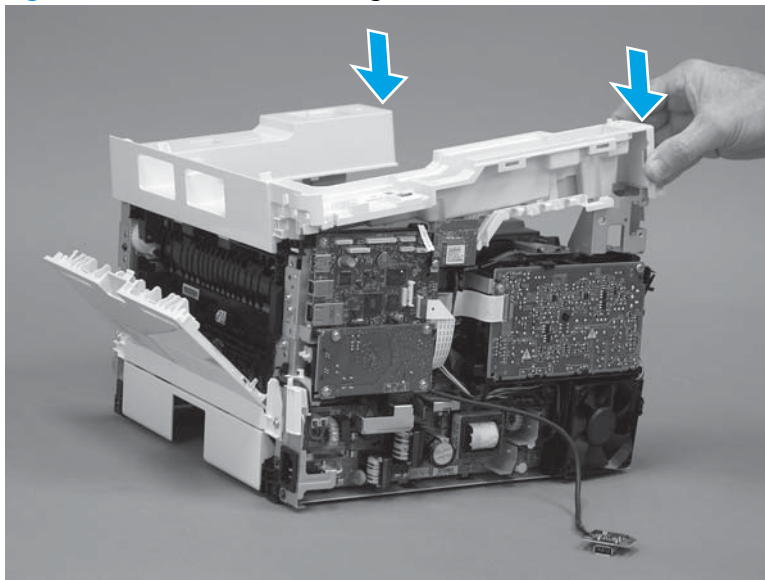

4. Install the USB cable (callout 1) in the guide.

Figure 1-329 Install the USB PCA

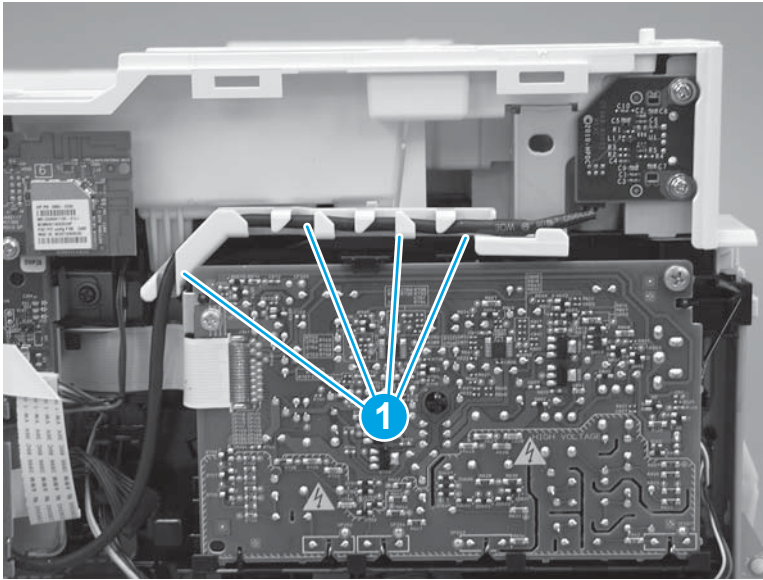

5. Install five screws (callout 1).

Figure 1-330 Install five screws

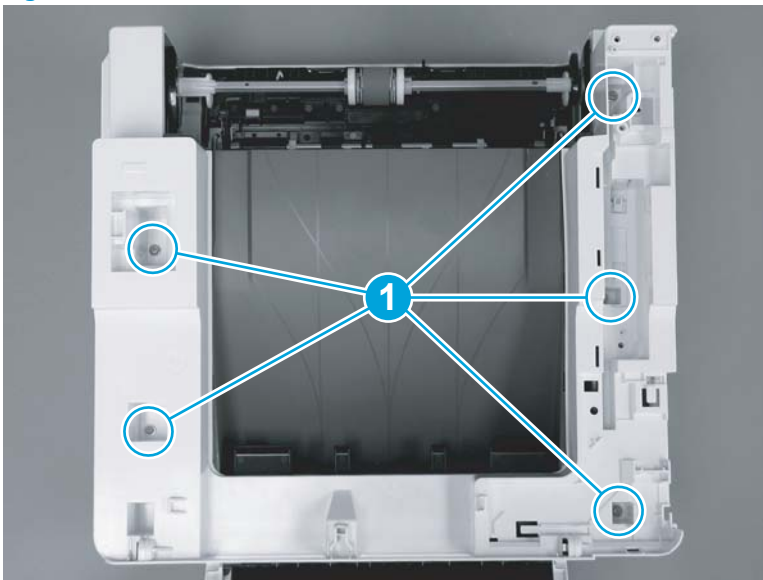

Step 12: Install the integrated scanner assembly (M427/M246)

 **NOTE:** M427/M246 models only. The integrated scanner assembly (ISA) includes the sub-scanner assembly (SSA) and the automatic document feeder (ADF).

1. Position the ISA on the printer.

Figure 1-331 Position the ISA on the printer

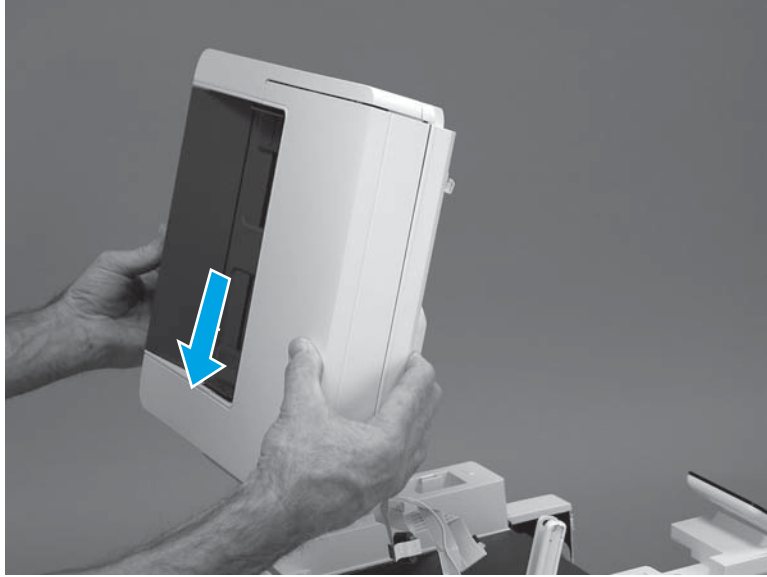

2. Engage the hinge pins on the ISA with the holders in the top cover (callouts 1/2), and then slide the ISA as shown to engage them

Figure 1-332 Engage the hinge pins with the holders

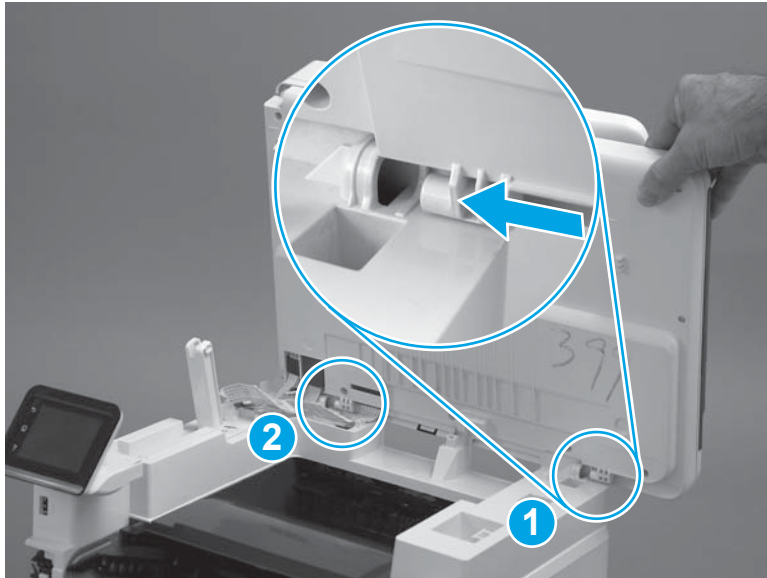

3. Rotate the ISA towards the front of the printer until it rests on the ISA lift assembly (callout 1).

Figure 1-333 Rotate the ISA towards the front of the printer

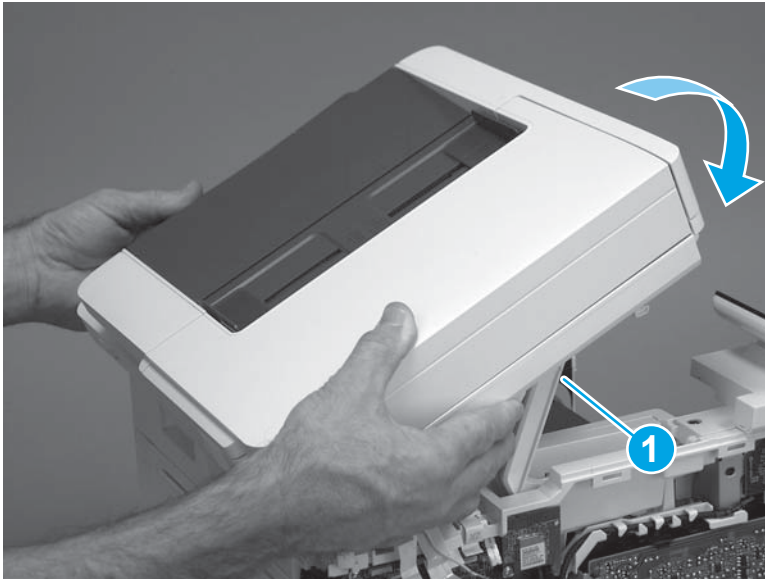

4. Pass the ground wire through the opening in the top cover.

Figure 1-334 Pass the wire through the opening

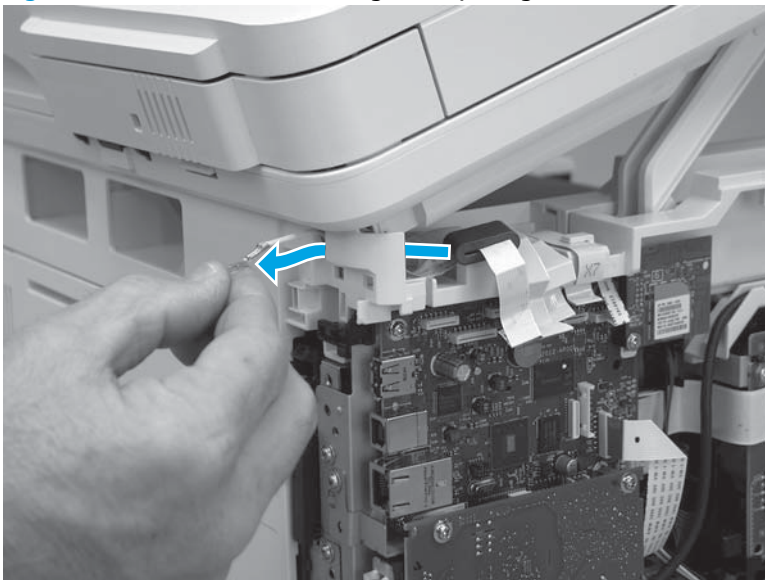

5. Install one screw (callout 1).

Figure 1-335 Install one screw

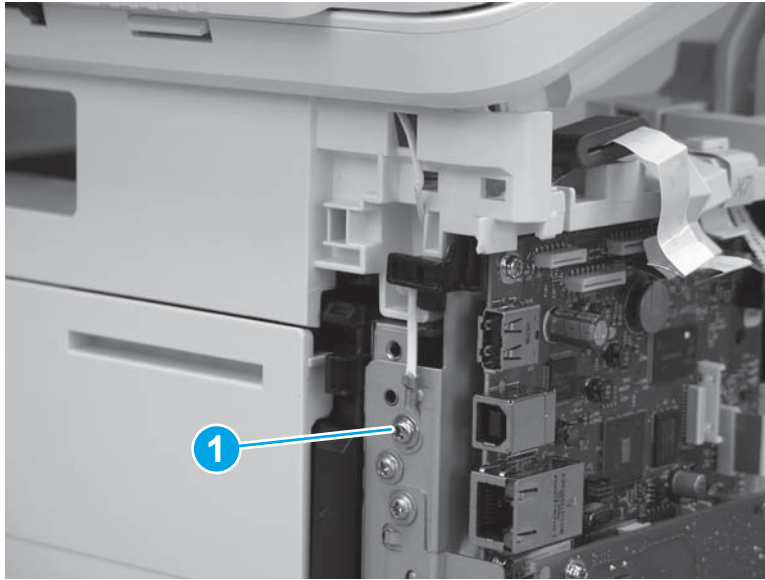

6. Install the ISA lift assembly slider pin.

 **Reinstallation tip:** Align the keyed portion of the locking pin with the slot and hole in the support arm.

Figure 1-336 Install the slider pin



7. Rotate the slider pin (callout 1) towards the rear of the printer until the tab (callout 2) snap into place.

Figure 1-337 Secure the slider pin

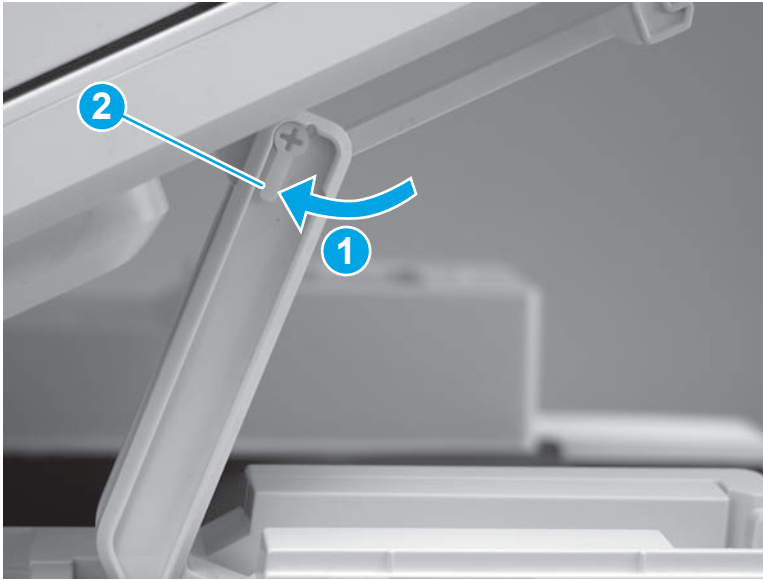

8. Install the ferrite (callout 1) in the holder, and then connect three FFCs (callout 2).

Figure 1-338 Connect three FFCs

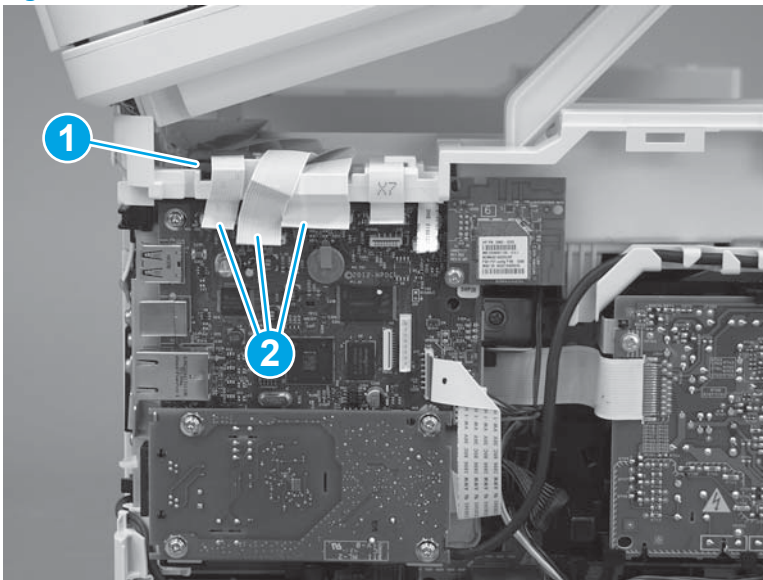

9. Position the rear edge of the ISA flat-flexible cable (FFC) cover on the printer (callout 1) , and then rotate it down (callout 2) until it snaps into place.

Figure 1-339 Install the ISA FFC cover

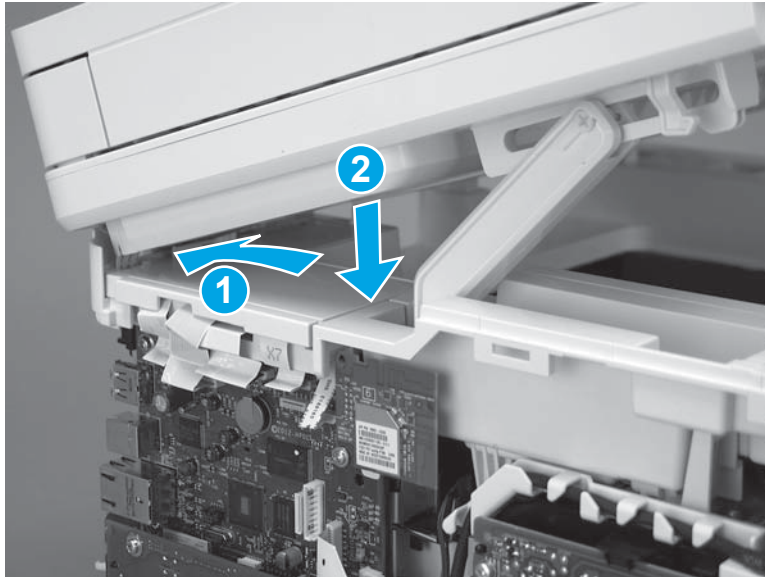

10. Lower the ISA.

Figure 1-340 Lower the ISA

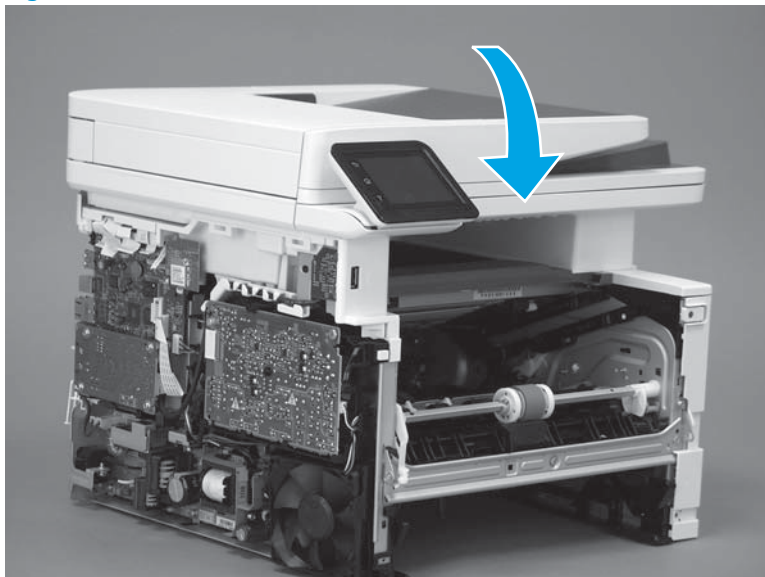

Step 13: Install the control panel (M427/M426)

1. Slide the control-panel FFC cover into the slot in the top cover (next to the document feeder support arm) to install it.

Figure 1-341 Install the control-panel FFC cover

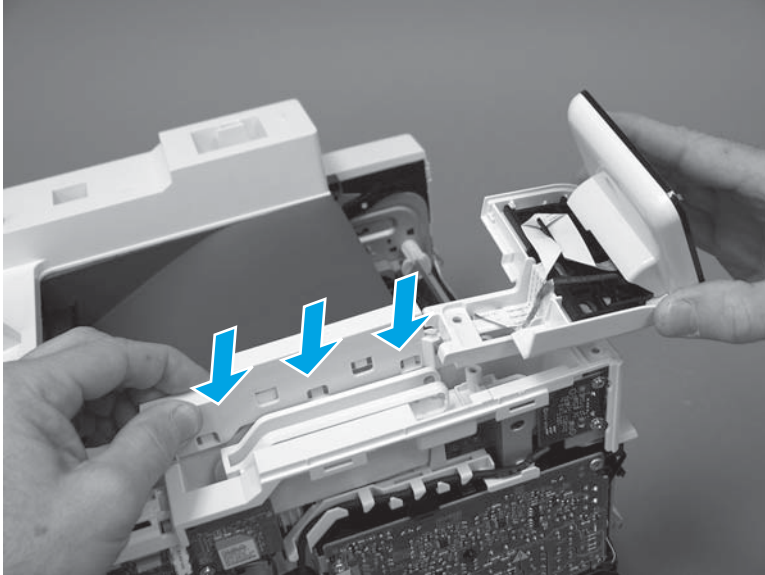

2. Install the control-panel assembly on the top cover.

Figure 1-342 Install the control-panel assembly

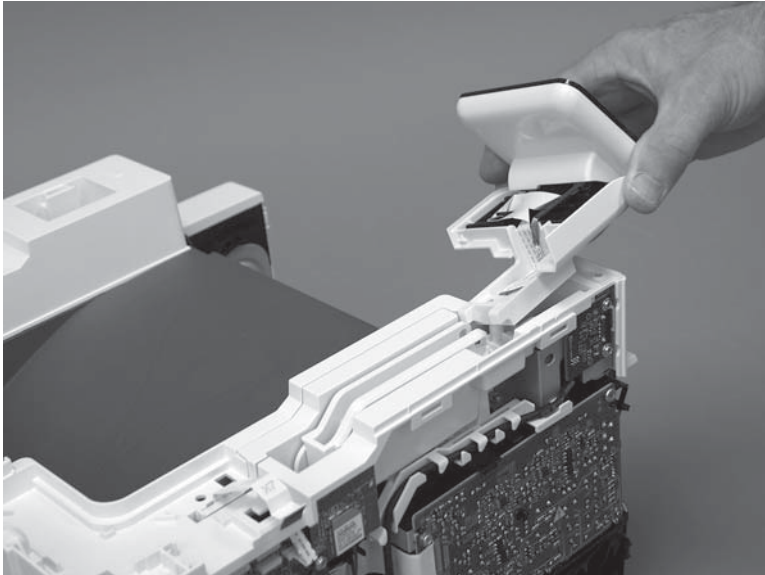

3. Move the FFC out of the way, and then install two screws (callout 1).

Figure 1-343 Install two screws

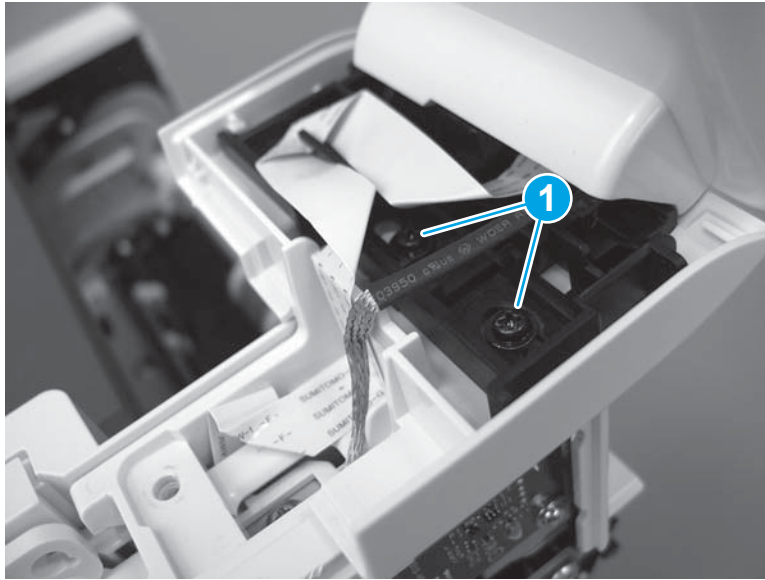

4. Install one grounding screw (callout 1), and then make sure that the ground cable (callout 2) is properly routed.

Figure 1-344 Remove one screw

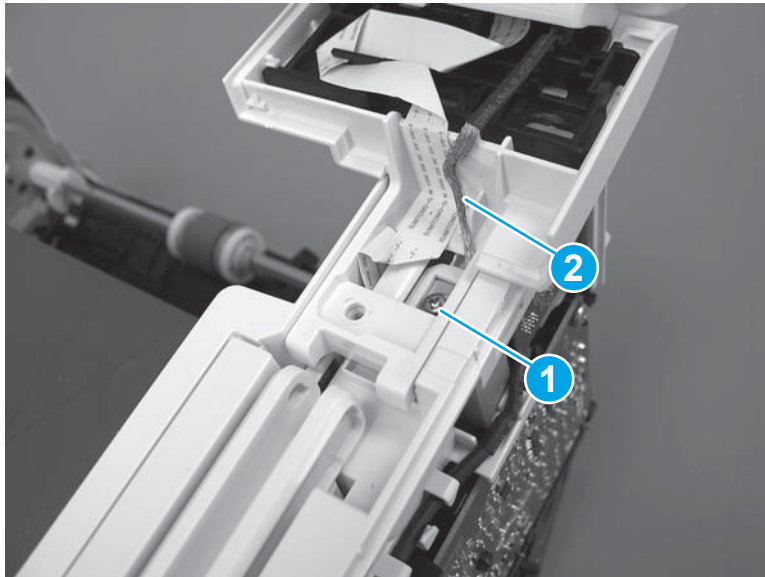

5. Install the control-panel cable cover.

Figure 1-345 Install the cover

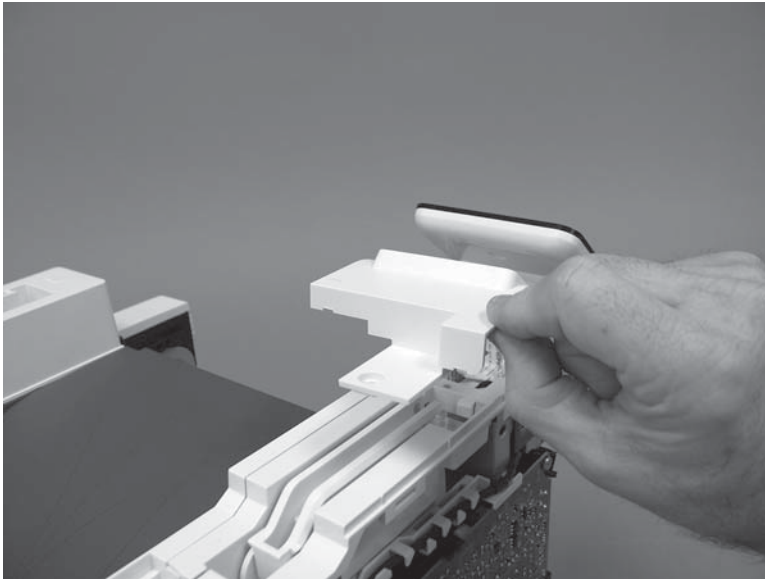

6. Make sure that the two tabs (callout 1) on the cover snap into place.

Figure 1-346 Engage two tabs

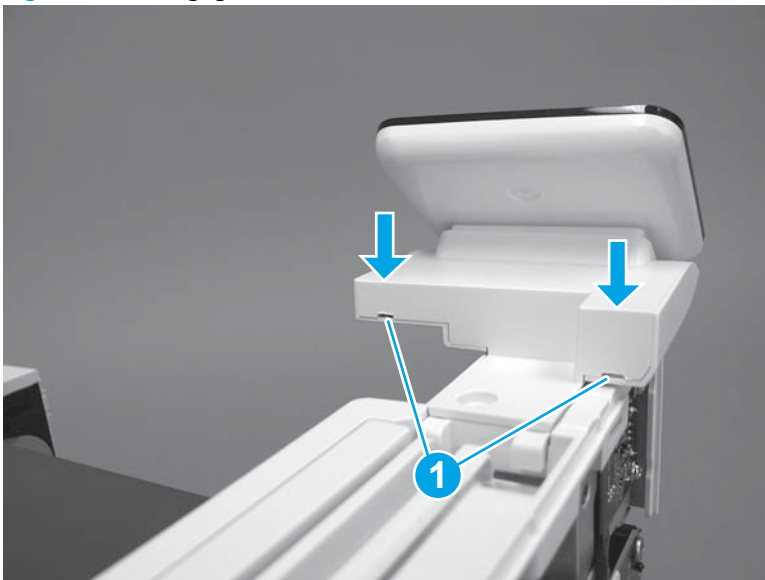

7. Install one screw (callout 1).

Figure 1-347 Install one screw

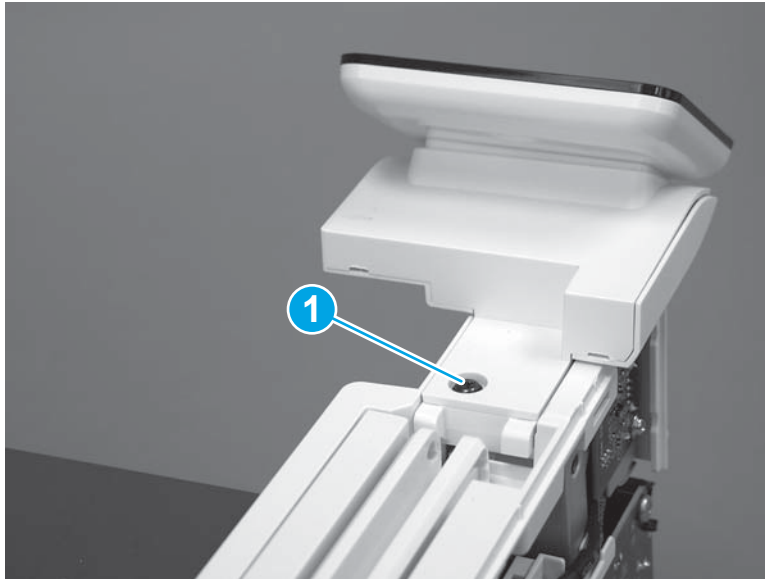

8. Install the FFC in the retainer (callout 1), and then connect one FFC (callout 1; J114).

Figure 1-348 Connect one connector

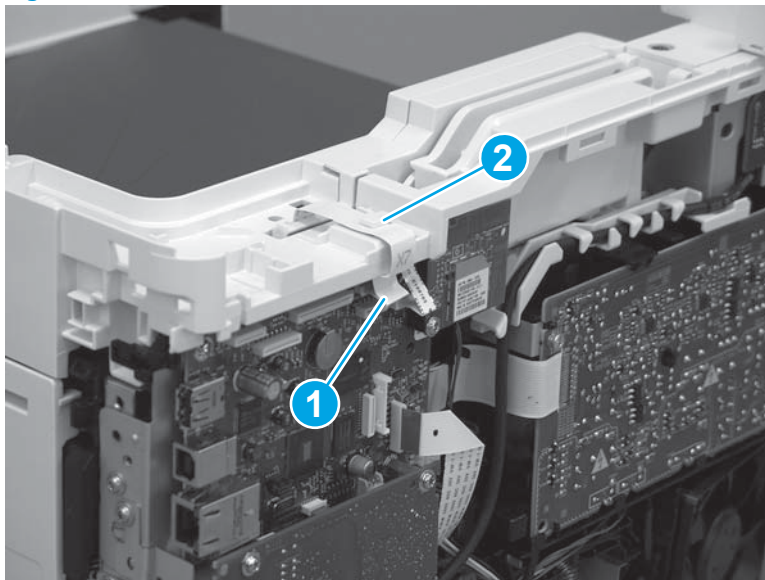

Step 14: Install the right cover

1. Position the cover (callout 1) on the printer, and then engage two bosses (callout 2).

Figure 1-349 Install the cover

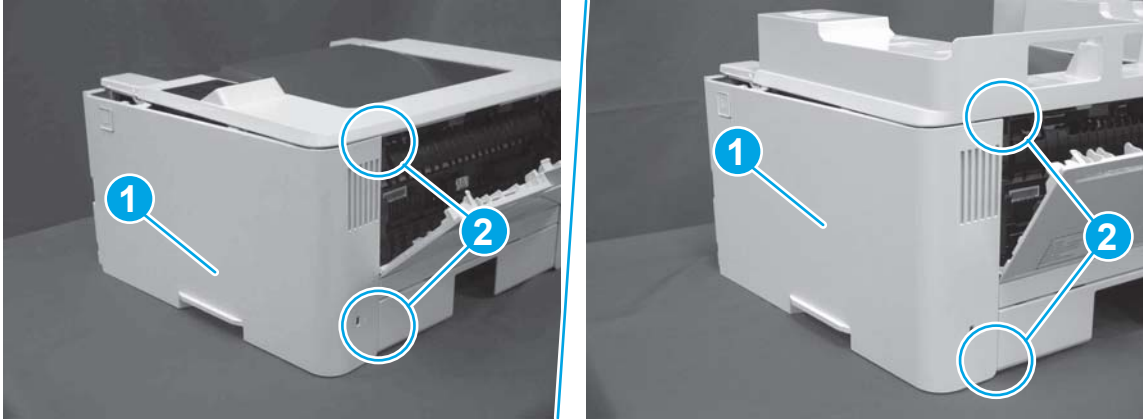

2. Rotate the front of the cover onto the printer (callout 1), engage three (callout 2) tabs, and then engage two bosses (callout 3).

Figure 1-350 Engage two bosses and one tab

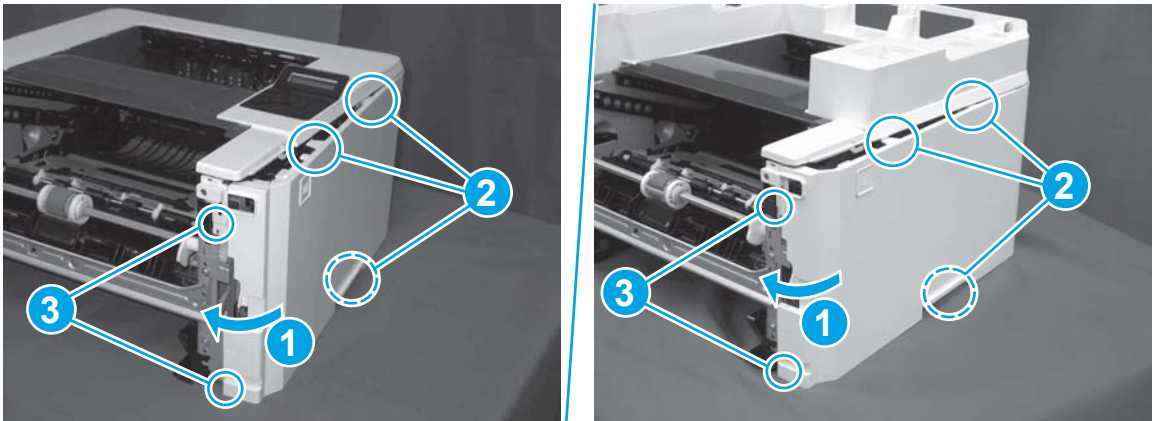

3. Make sure that the power switch (callout 1) and cartridge door assembly button (callout 2) correctly function.

 **NOTE:** Remove, and then reinstall the cover if the switch or button does not correctly function.

Figure 1-351 Check the power switch and cartridge door assembly button



4. Install one screw (callout 1).

Figure 1-352 Install one screw

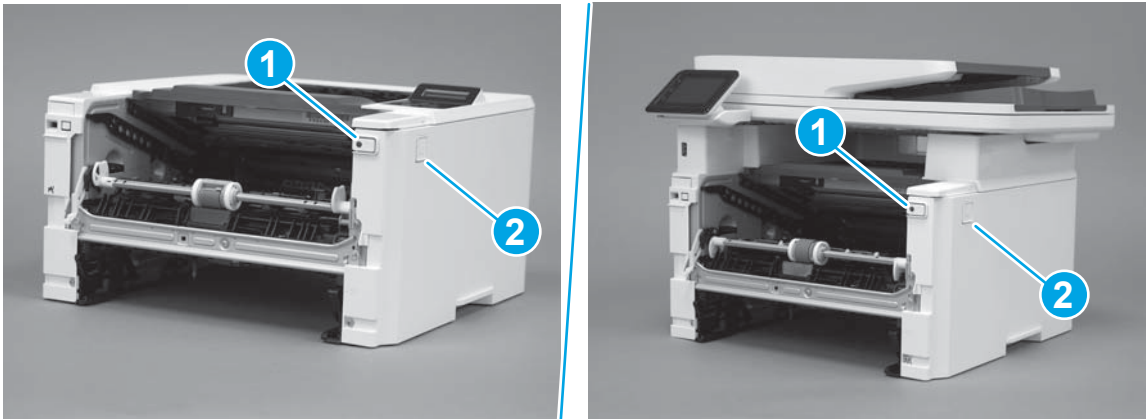

Step 15: Install the left cover

1. At the front of the printer, do one of the following:
 - **M403/M402:** Position the cover on the printer (callout 1), and then engage two bosses (callout 2).
 - **M427/M426:** Position the cover on the printer (callout 3), engage one tab (callout 4), and then engage two bosses (callout 4).

Figure 1-353 Install the cover

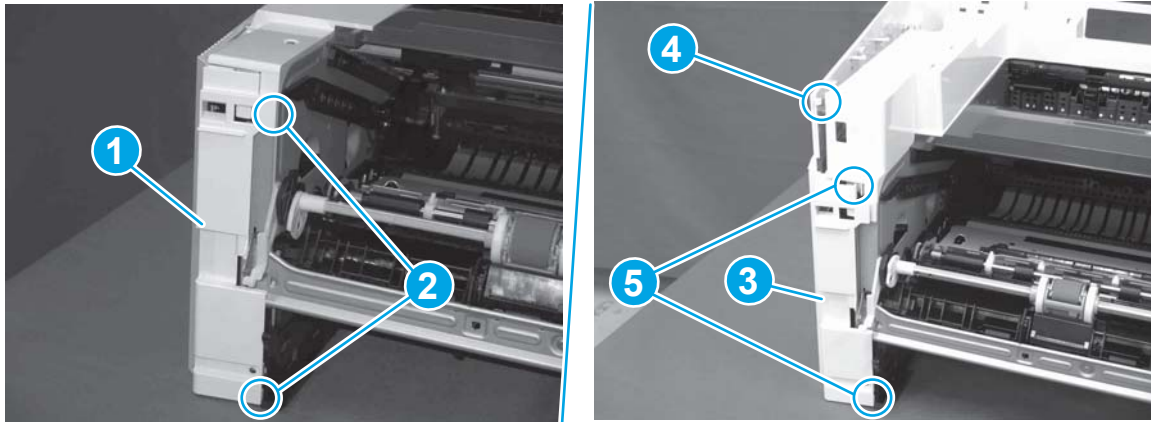

- Carefully rotate the rear of the cover onto the printer (callout 1), engage three tabs (callout 2), and then engage two bosses (callout 3).

Figure 1-354 Engage three tabs and two bosses

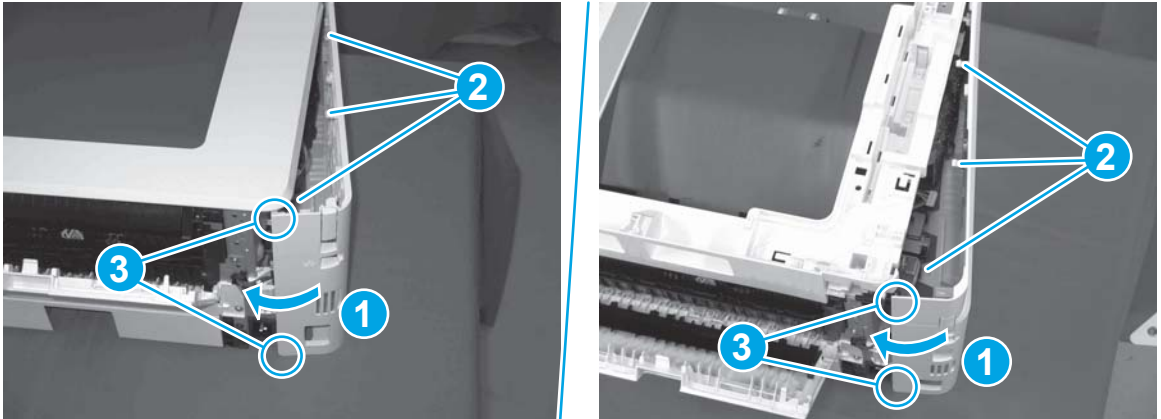

- Install one screw (callout 1).

Figure 1-355 Install one screw

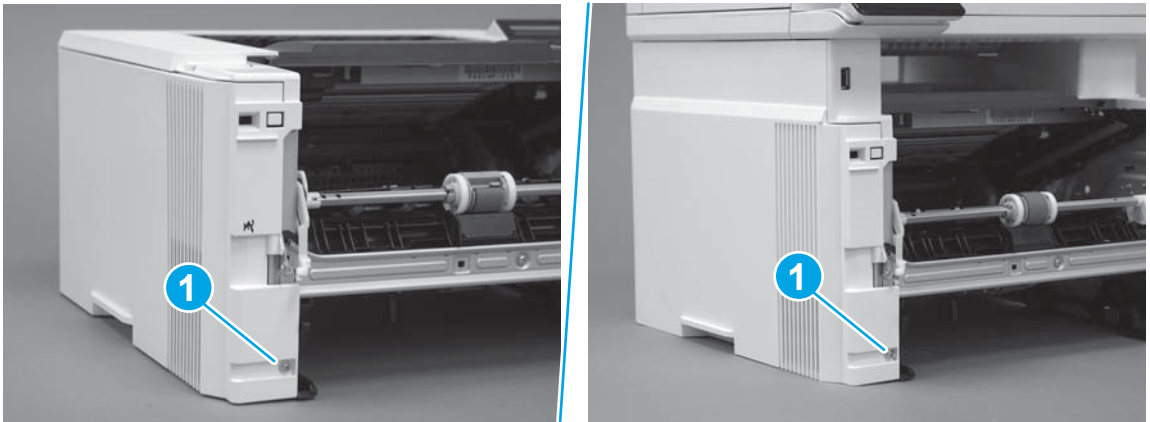

Step 16: Install the cartridge door assembly

 **Reinstallation tip:** After a replacement door is installed, make sure to install the nameplate (supplied in the kit) corresponding to the printer name on the door.

- Position the door close to the printer, and then engage the keyed pin on the left-side retainer arm with the hole in the door.

Figure 1-356 Engage the left-side retainer arm

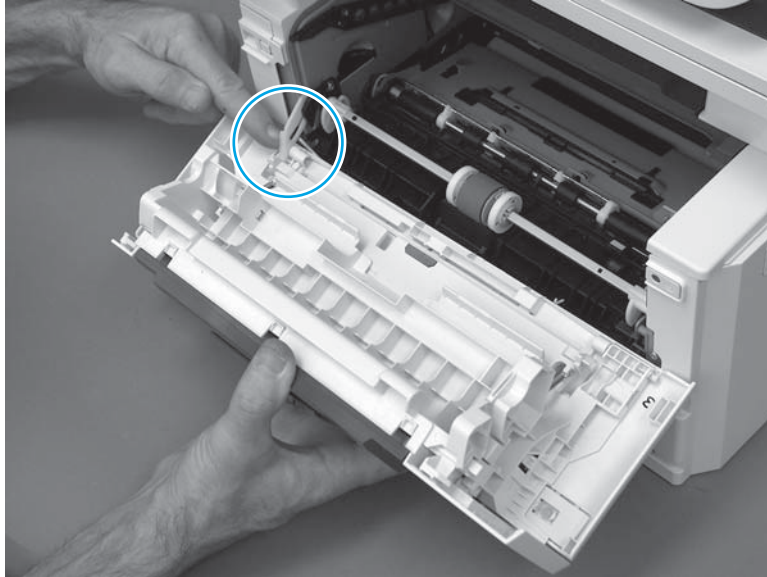

2. Engage the right-side door hinge pin with the hole in the chassis (callout 1).

Figure 1-357 Install the door

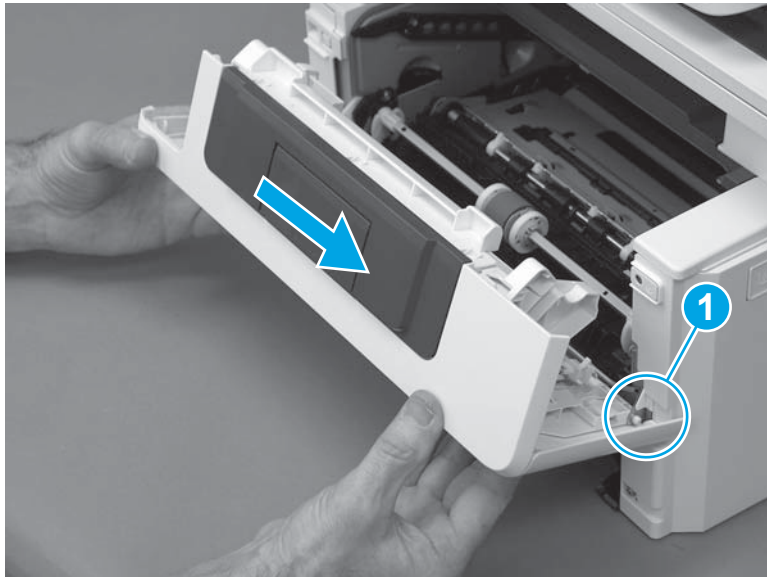

3. Install the link (callout 1).

 **IMPORTANT:** Make sure that the link snaps into place on the arm (callout 2). The link actuates the fuser pressure-release mechanism.

Figure 1-358 Install the pressure-release link

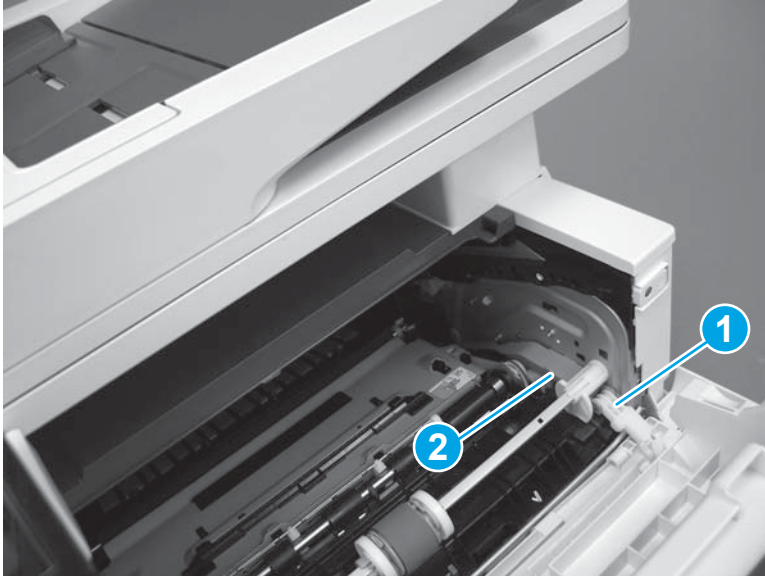

4. Slide the guide into the printer (callout 1), and then make sure that the tab (callout 2) snaps into place to secure the guide to the chassis.

Figure 1-359 Install the guide

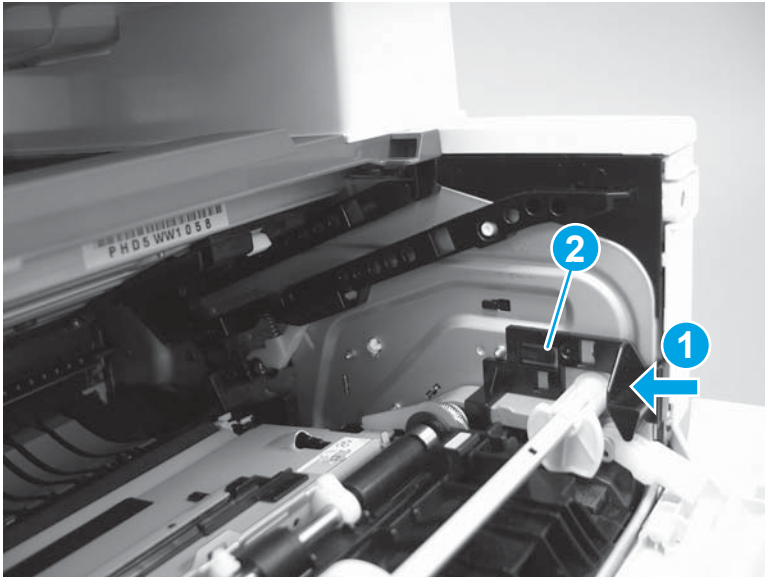

5. Position the shaft on the door, and then align the left-side hinge on the door with the hole in the chassis (callout 1).

Figure 1-360 Align the hinge

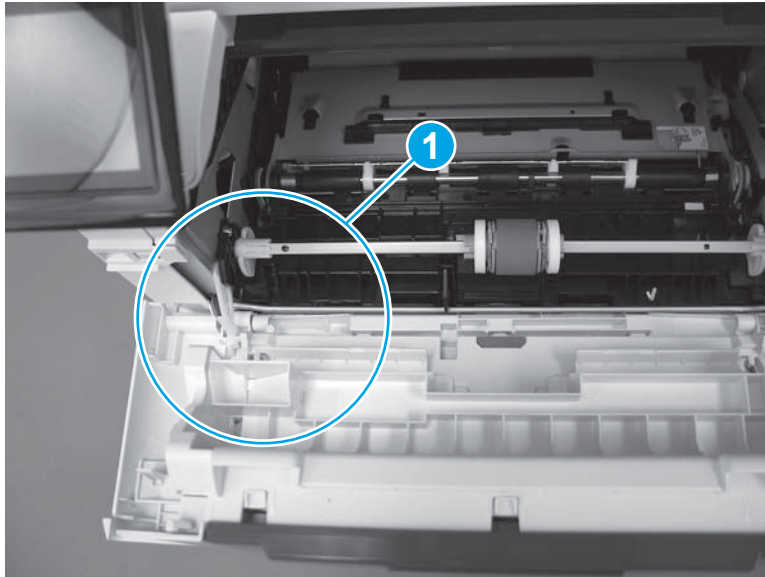

6. Push the shaft towards the left side of the printer to install it (callout 1).

 **Reinstallation tip:** Make sure that the support shaft is fully installed and correctly orientated (callout 2) so that it will not interfere with the door opening and closing.

Figure 1-361 Install the support shaft



Step 17: Install Tray 2

- ▲ Slide the tray straight into the printer to install it.

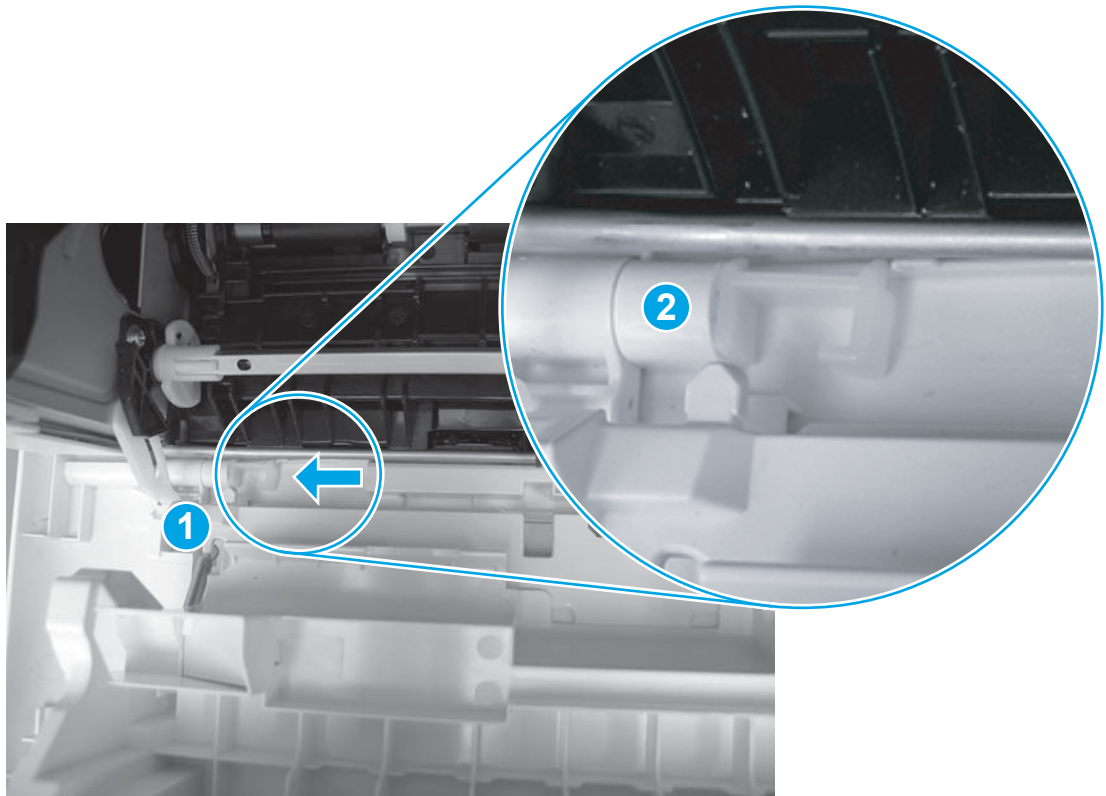
Figure 1-362 Install the tray



Removal and replacement: Top cover (M403/M402)

- [Introduction](#)
- [Step 1: Remove Tray 2](#)
- [Step 2: Remove the cartridge door assembly](#)
- [Step 3: Remove the left cover](#)
- [Step 4: Remove the right cover](#)
- [Step 5: Remove the top cover \(M403/M402\)](#)
- [Step 6: Remove the 2-line LCD operator and indication covers \(M403/M402\)](#)
- [Step 7: Unpack the replacement assembly](#)
- [Step 8: Install the 2-line LCD operator and indication covers \(M403/M402\)](#)
- [Step 9: Install the top cover \(M403/M402\)](#)
- [Step 10: Install the right cover](#)
- [Step 11: Install the left cover](#)
- [Step 12: Install the cartridge door assembly](#)
- [Step 13: Install Tray 2](#)

Introduction

This document provides the procedures to remove and replace the top cover (M403/M402).

Before performing service

Turn the printer power off

- Disconnect the power cable.

 **WARNING!** To avoid damage to the printer, turn the printer off, wait 30 seconds, and then remove the power cable before attempting to service the printer.

Use the table below to identify the correct part number for your printer. To order the part, go to www.hp.com/buy/parts.

Top cover (M403/M402) part number	
RC4-2956-000CN	Top cover (M403/M402)

Required tools

- #2 Phillips screwdriver with a magnetic tip.

After performing service

Turn the printer power on

- Connect the power cable.
- Use the power switch to turn the power on.

Post service test

Make sure that the printer initializes to a **Ready** state.

Print a configuration page to make sure that the printer is functioning correctly.

Step 1: Remove Tray 2

- ▲ Pull the tray straight out of the printer to remove it.

Figure 1-363 Remove the tray



Step 2: Remove the cartridge door assembly

 **NOTE:** If the toner cartridge was not removed prior to servicing the printer, remove it now.

1. Release one tab (callout 1), and then slide shaft (callout 2) in the direction the arrow indicates and remove it.

 **TIP:** It might be easier to release the support shaft by using a small flat-blade screwdriver.

Figure 1-364 Release the support shaft

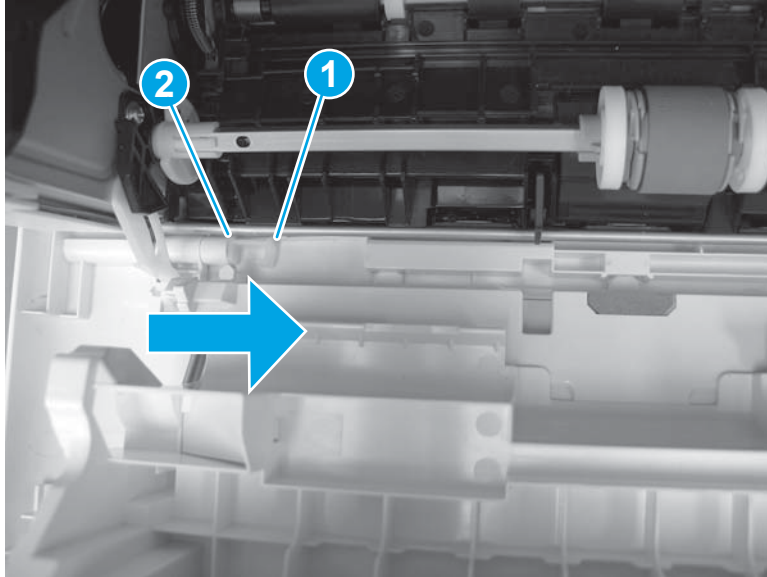

2. Release one tab (callout 1), and then slide the guide (callout 2) in the direction the arrow indicates and remove it.

Figure 1-365 Remove the guide

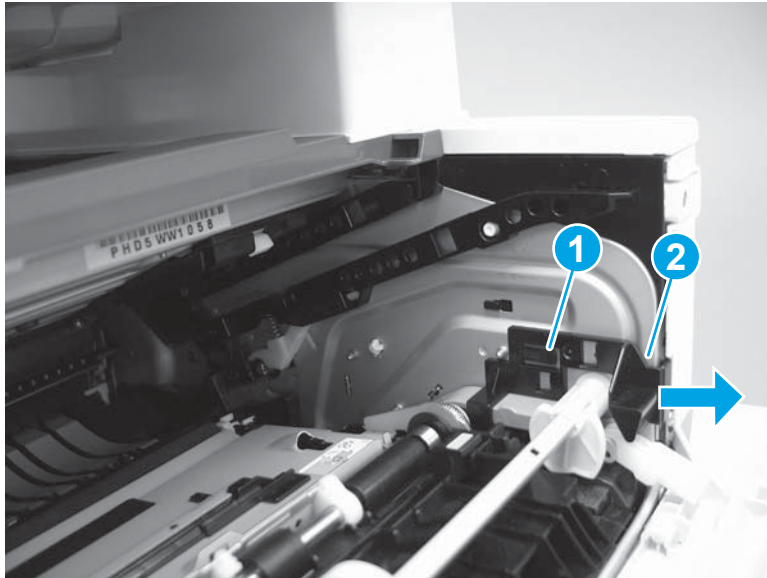

3. Remove the link arm (callout 1).

Figure 1-366 Remove the link arm

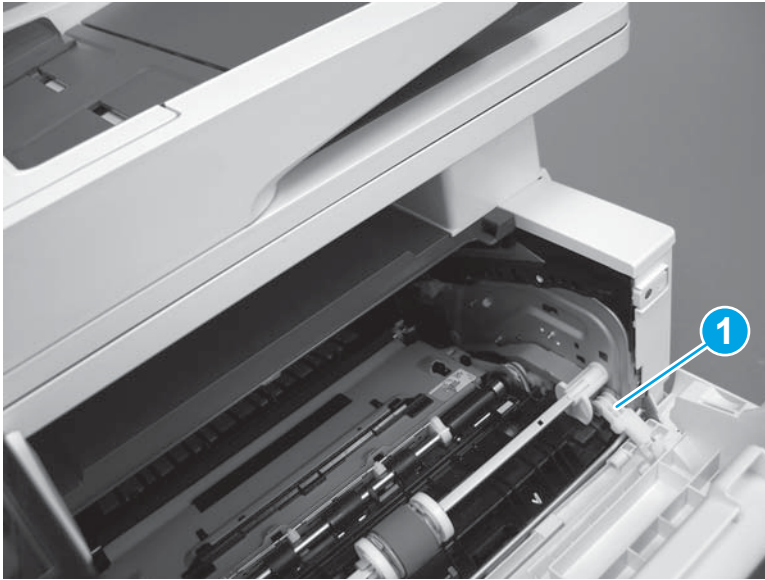

4. Slide the cartridge door assembly (callout 1) in the direction the arrow indicates and remove it.

Figure 1-367 Remove the door

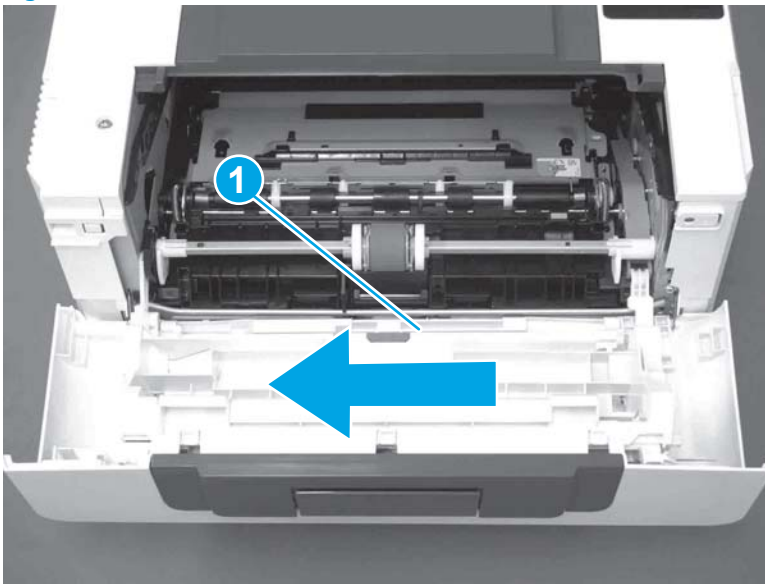

5. Remove the link (callout 1) from the cartridge door assembly (callout 2).

Figure 1-368 Release the left-side retainer arm

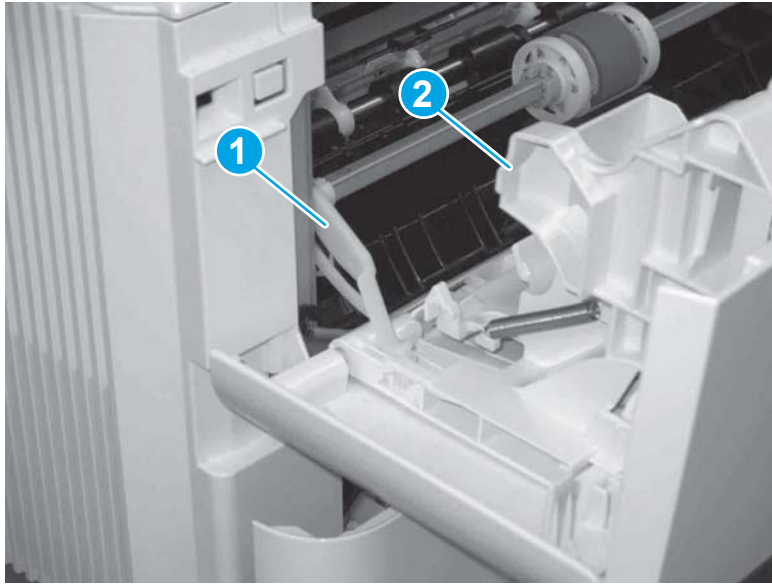

Step 3: Remove the left cover

1. Remove one screw (callout 1).

Figure 1-369 Remove one screw

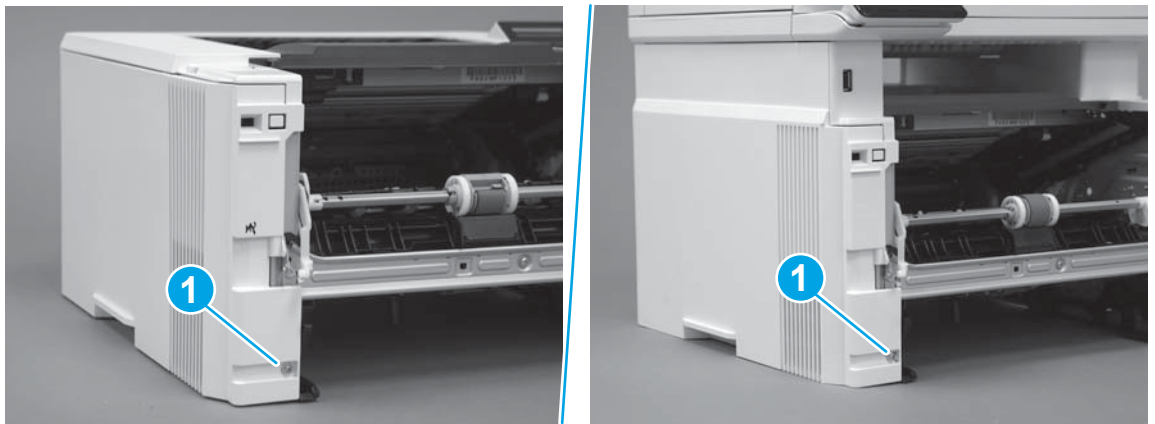

2. Open the rear door, release two bosses (callout 1), and then release three tabs (callout 2).

Figure 1-370 Release two bosses and three tabs

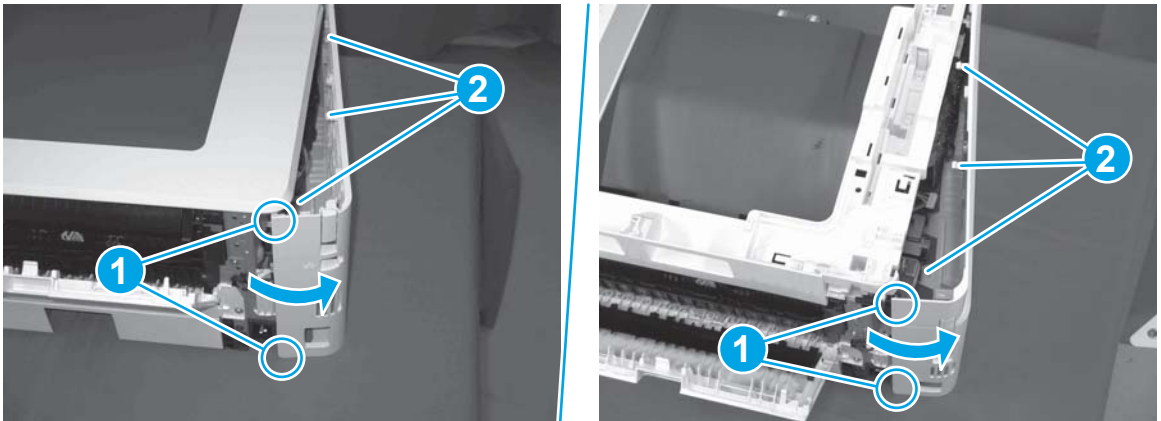

3. At the front of the printer, do one of the following:
 - **M403/M402:** Release two bosses (callout 1), and then remove the cover (callout 2).
 - **M427/M426:** Release one tab (callout 3), two bosses (callout 4), and then remove the cover (callout 5).

CAUTION: Be careful when releasing the upper bosses on the M427/M426 cover. One portion of the cover (callout 6) is fragile and is easily broken.

Figure 1-371 Remove the cover

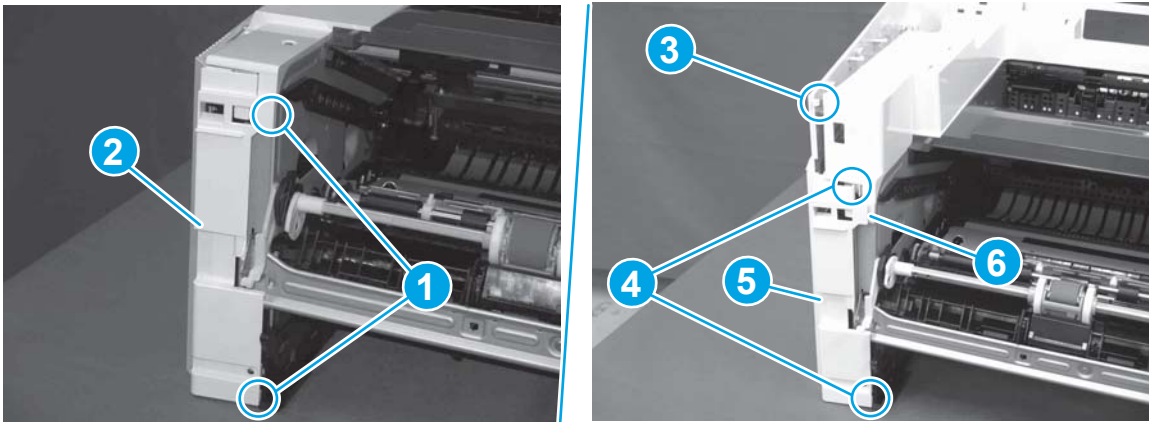

Step 4: Remove the right cover

1. Remove one screw (callout 1).

Figure 1-372 Remove one screw

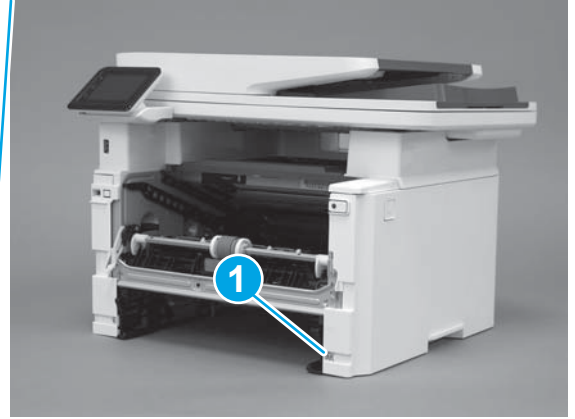
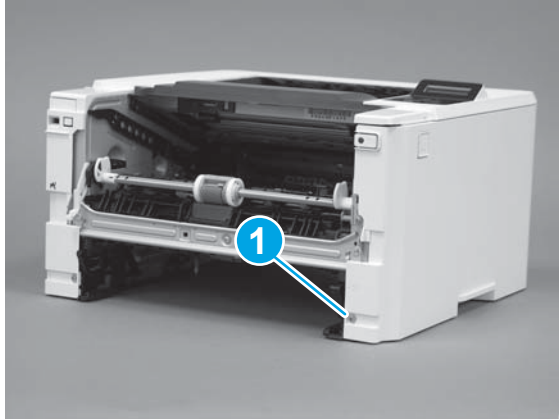

2. At the front of the printer, release two bosses (callout 1), and then release three tabs (callout 2).

Figure 1-373 Release two bosses and three tabs

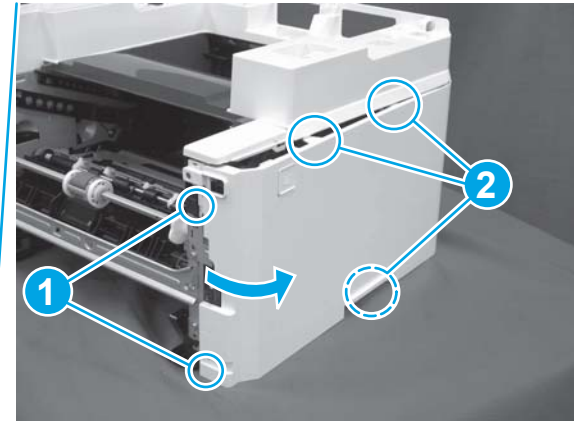
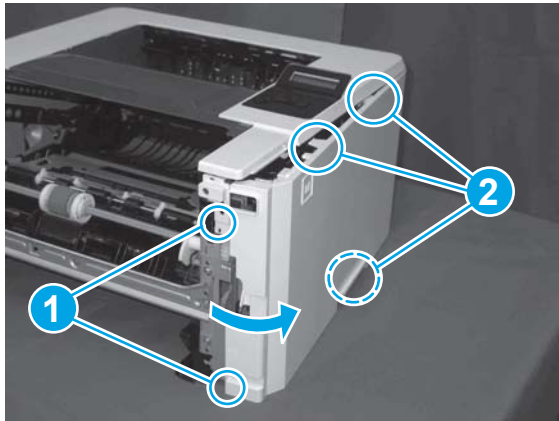

3. Open the rear door, release two bosses (callout 1), and then remove the cover (callout 2).

Figure 1-374 Remove the cover

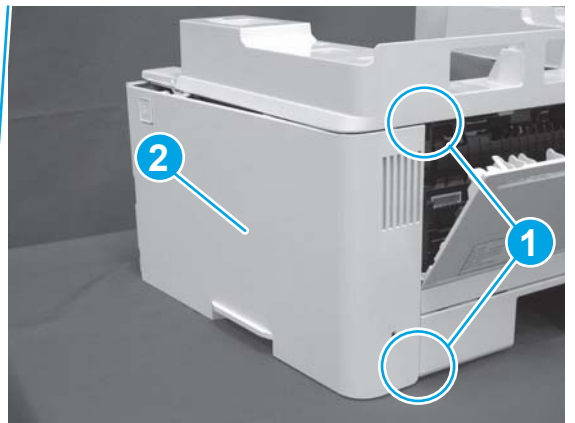
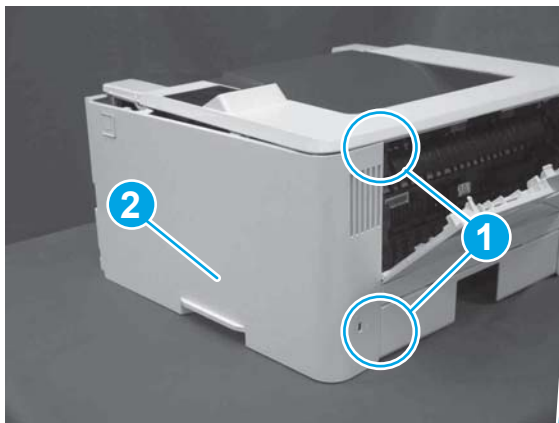

Step 5: Remove the top cover (M403/M402)

1. Remove one screw (callout 1).

Figure 1-375 Remove one screw



2. At the right side of the printer, release the one boss (callout 1), and then release one tab (callout 2).

Figure 1-376 Release one boss and one tab

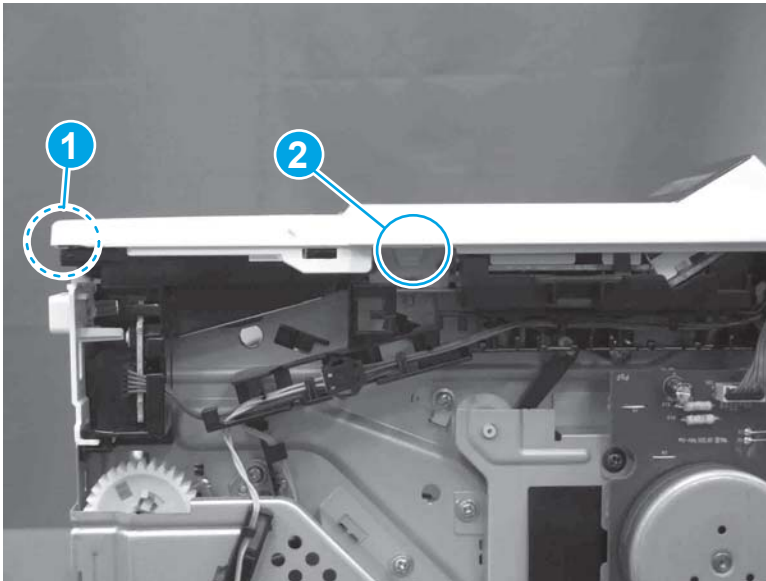

3. Release four tabs (callout 1), release four bosses (callout 2), and then remove the top cover (callout 3).

 **TIP:** Open the rear door to make releasing the bosses (callout 3) easier.

Figure 1-377 Remove the cover



Step 6: Remove the 2-line LCD operator and indication covers (M403/M402)

1. Rotate the top edge of the operator cover away from the printer to release it.

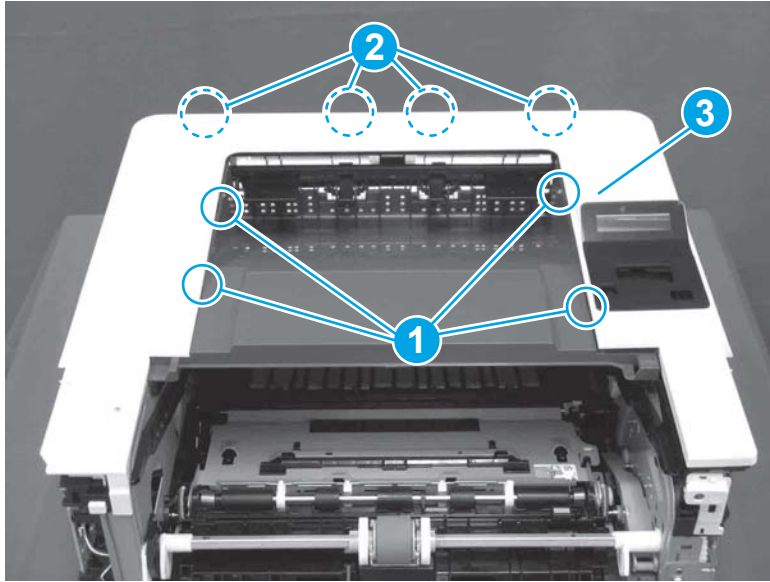
Figure 1-378 Rotate the top edge of the operator cover

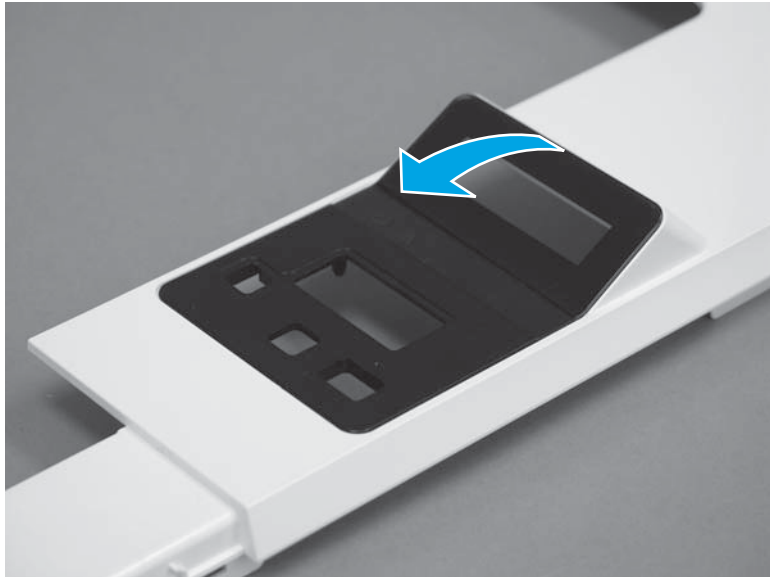

2. Remove the operator cover.

Figure 1-379 Remove the cover



3. Turn the top cover over, release two tabs (callout 1), and then remove the indication cover.

Figure 1-380 Remove the cover

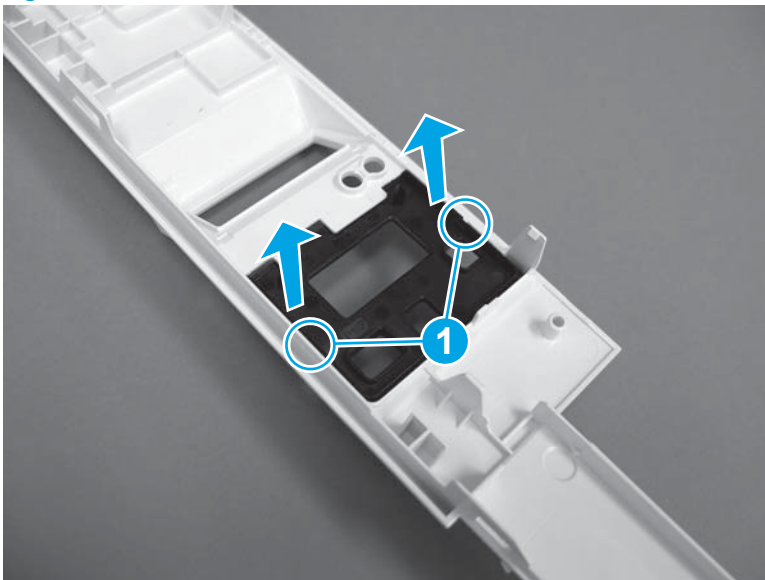

Step 7: Unpack the replacement assembly

Unpack the replacement part from the packaging.

<http://www8.hp.com/us/en/hp-information/environment/product-recycling.html>



NOTE: HP recommends responsible disposal of the defective part.

Figure 1-381 Recycle and unpack

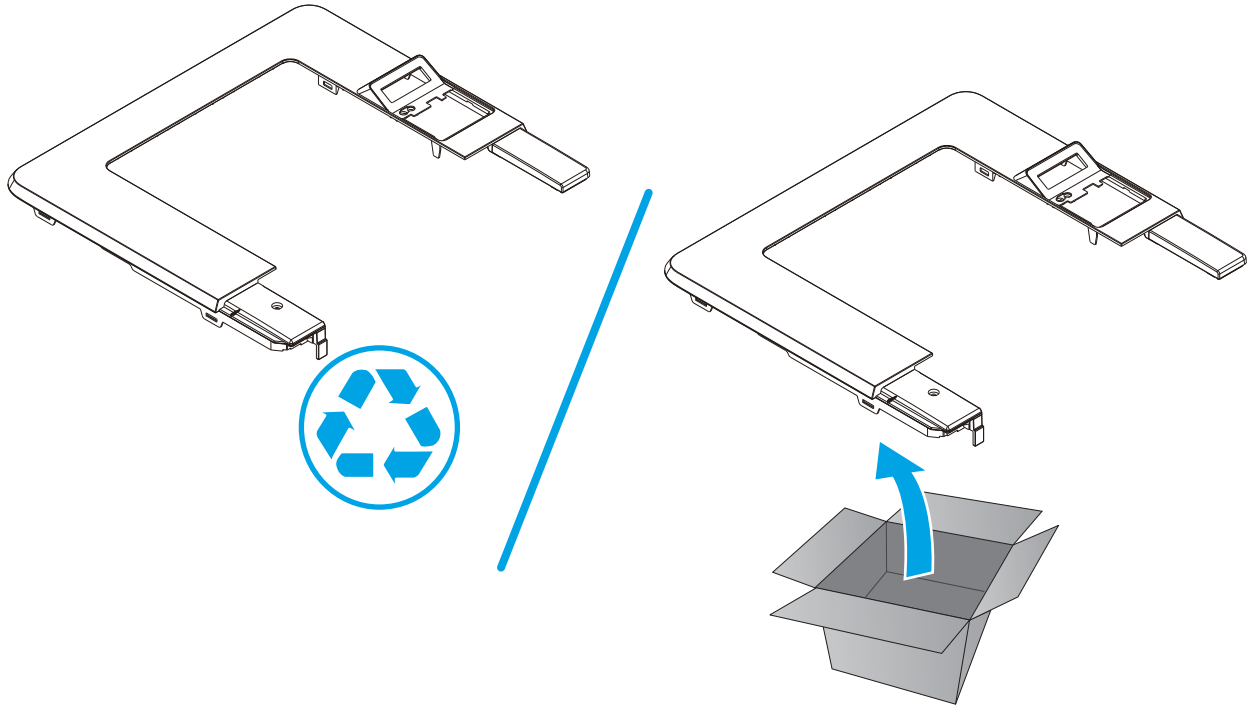

Step 8: Install the 2-line LCD operator and indication covers (M403/M402)

1. Position the indication cover on the top cover, and then make sure that the two tabs (callout 1) snap into place.

Figure 1-382 Install the cover

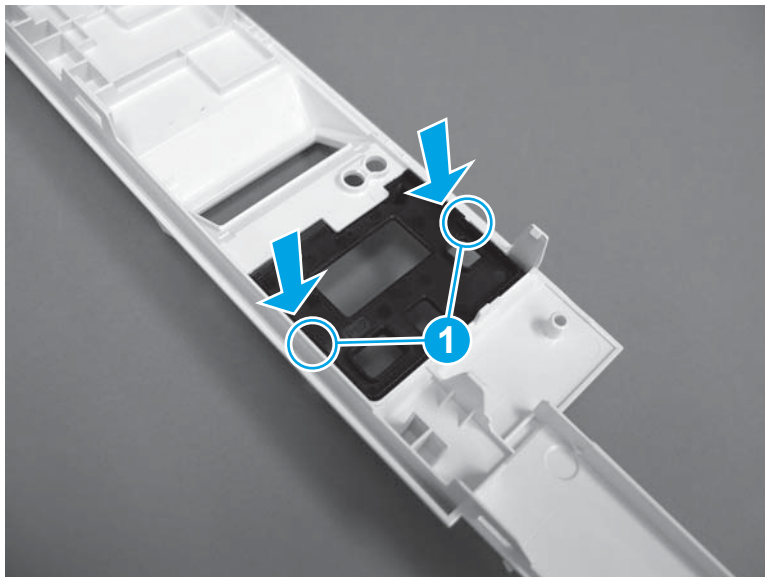

2. Turn the top cover over, and then position the bottom edge of the operator cover with the tab (callout 1) under the indication cover (callout 2).

Figure 1-383 Position the operator cover on the printer



3. Rotate the top edge of the cover towards from the printer to install it.

 **Reinstallation tip:** Use two-sided tape to secure the upper edge of the operator cover to the top cover.

Figure 1-384 Install the cover

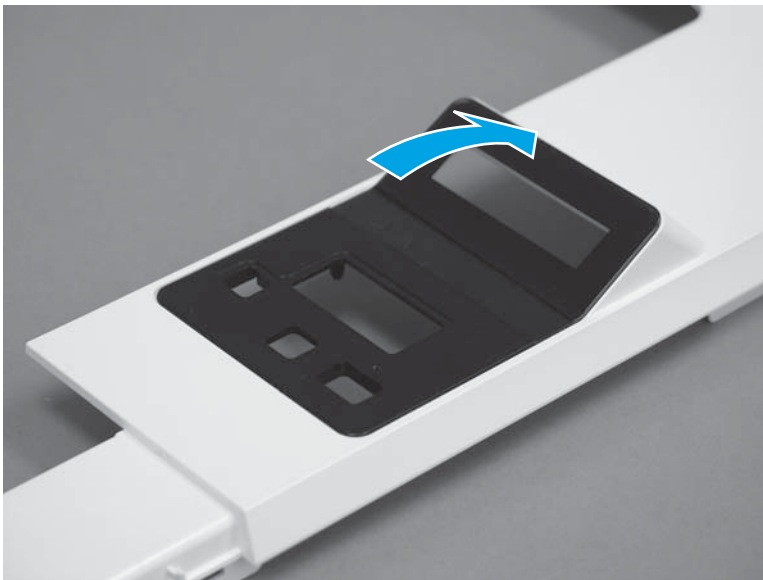

Step 9: Install the top cover (M403/M402)

1. Position the rear edge of the cover on the printer.

Figure 1-385 Install the cover

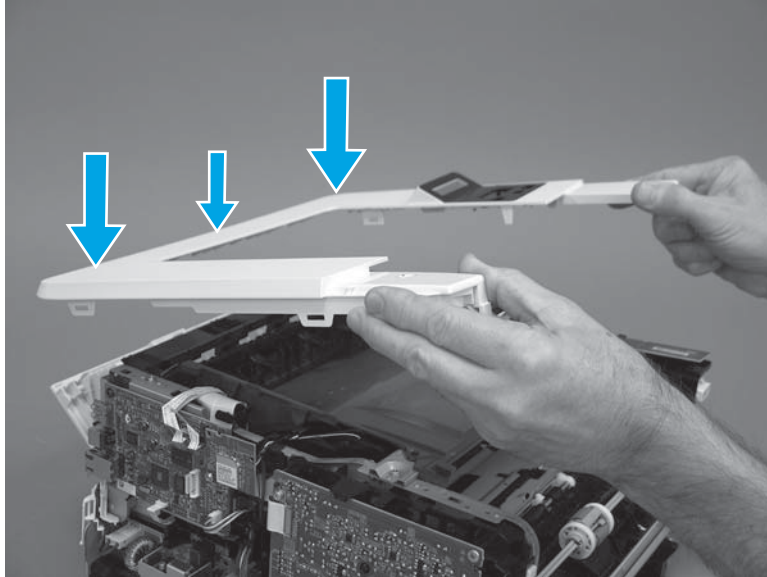

2. Engage four bosses (callout 1), rotate the front of the cover down (callout 2) and onto from the printer, and then engage four tabs (callout 3).

Figure 1-386 Engage four bosses and tabs

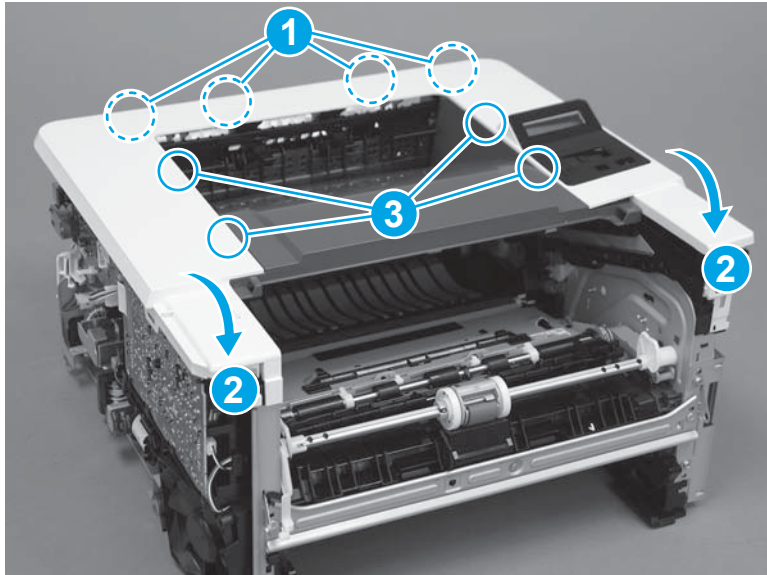

3. At the right side of the printer, engage the one boss and one tab (callout 1).

Figure 1-387 Engage one boss and one tab

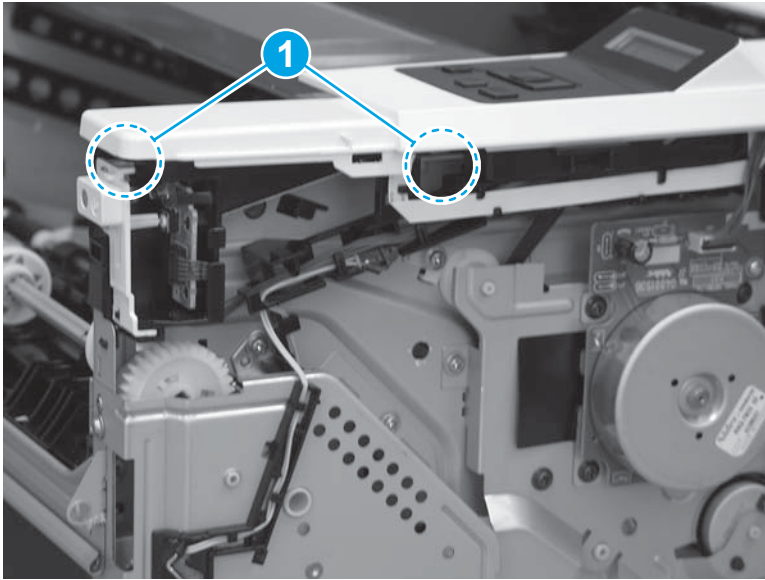

4. Install one screw (callout 1).

Figure 1-388 Install one screw

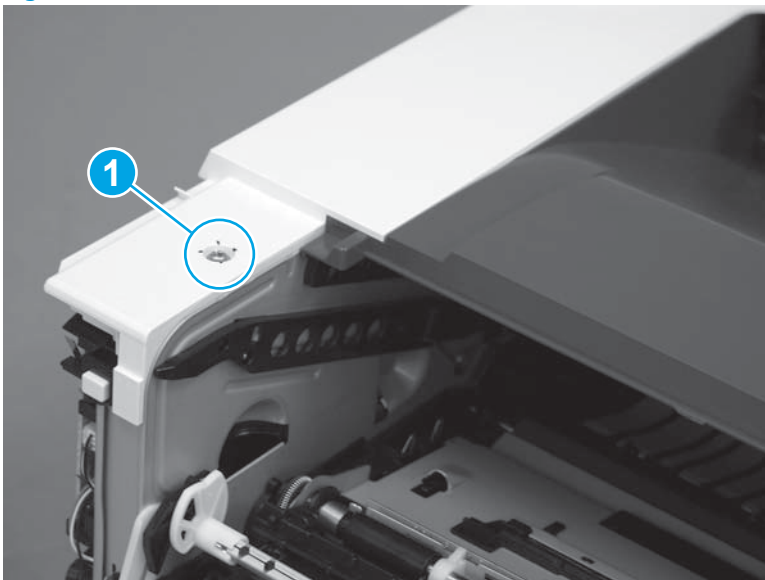

Step 10: Install the right cover

1. Position the cover (callout 1) on the printer, and then engage two bosses (callout 2).

Figure 1-389 Install the cover

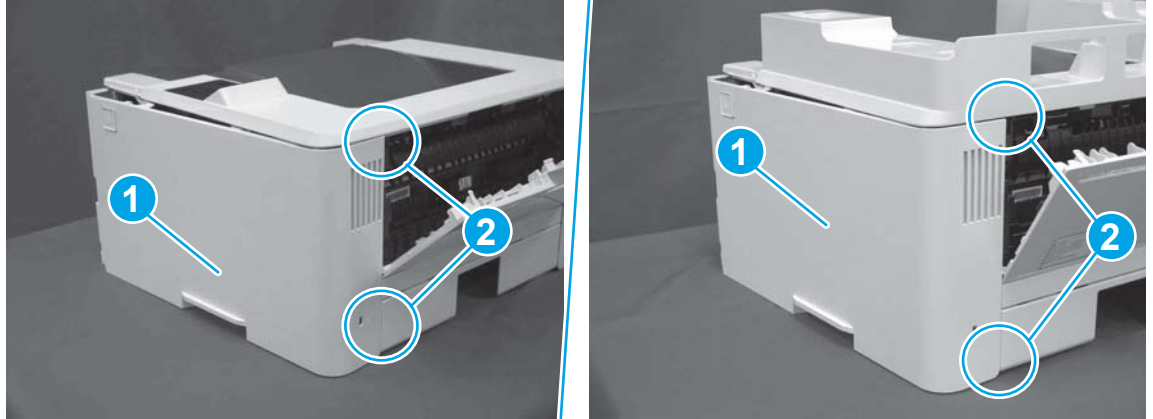

2. Rotate the front of the cover onto the printer (callout 1), engage three (callout 2) tabs, and then engage two bosses (callout 3).

Figure 1-390 Engage two bosses and one tab

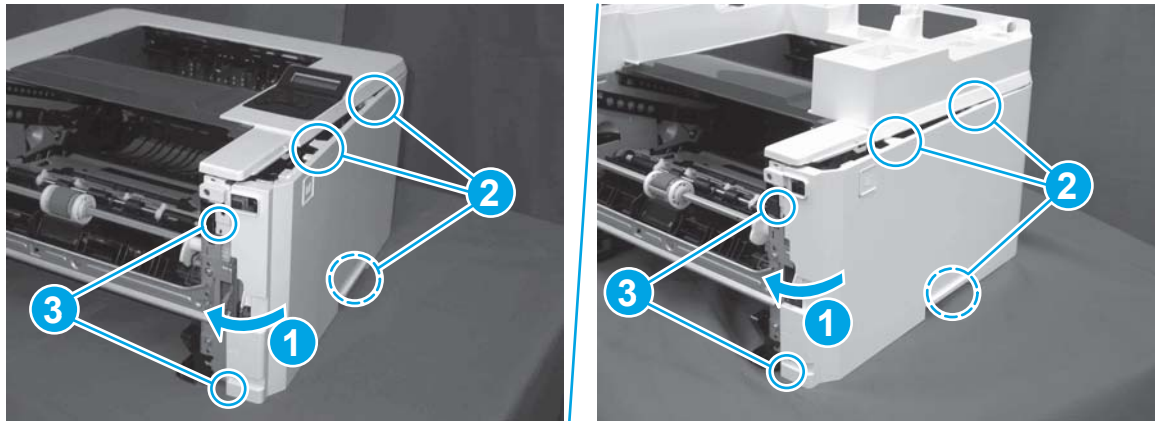

3. Make sure that the power switch (callout 1) and cartridge door assembly button (callout 2) correctly function.



NOTE: Remove, and then reinstall the cover if the switch or button does not correctly function.

Figure 1-391 Check the power switch and cartridge door assembly button

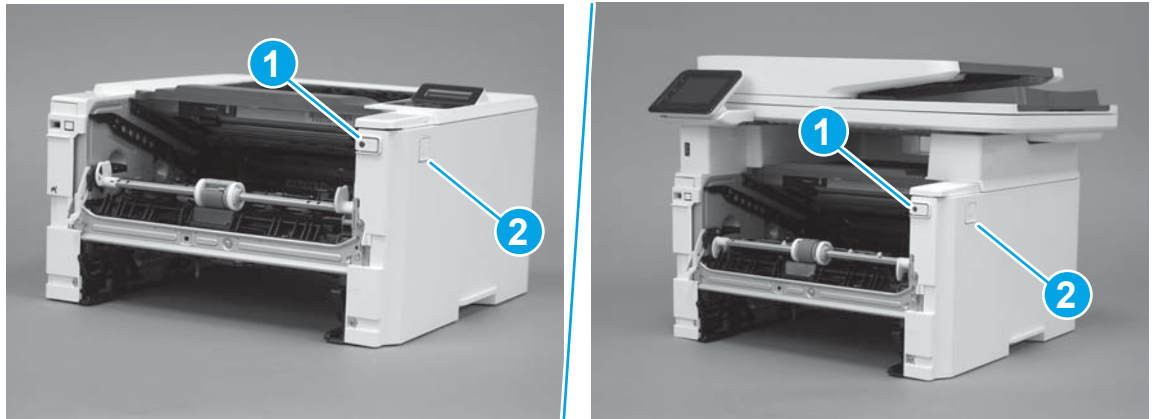

4. Install one screw (callout 1).

Figure 1-392 Install one screw



Step 11: Install the left cover

1. At the front of the printer, do one of the following:
 - **M403/M402:** Position the cover on the printer (callout 1), and then engage two bosses (callout 2).
 - **M427/M426:** Position the cover on the printer (callout 3), engage one tab (callout 4), and then engage two bosses (callout 4).

Figure 1-393 Install the cover

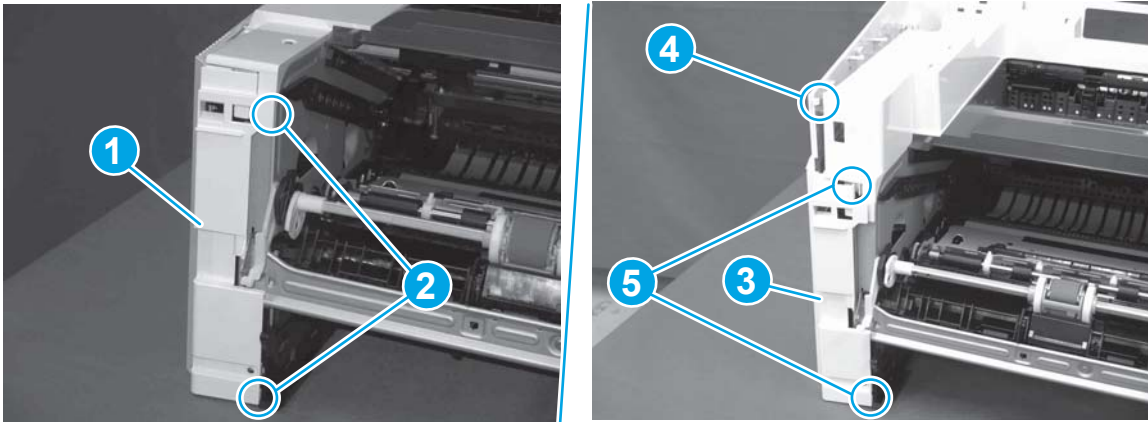

- Carefully rotate the rear of the cover onto the printer (callout 1), engage three tabs (callout 2), and then engage two bosses (callout 3).

Figure 1-394 Engage three tabs and two bosses

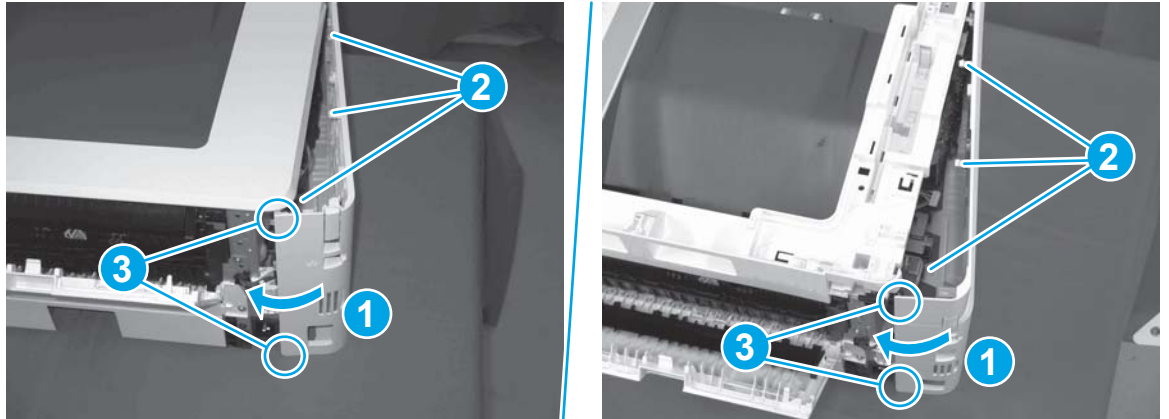

- Install one screw (callout 1).

Figure 1-395 Install one screw

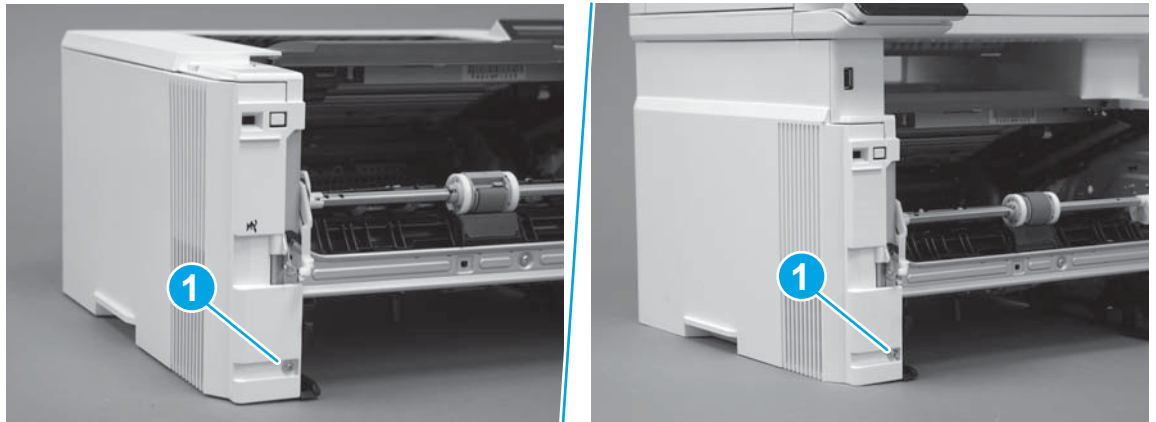

Step 12: Install the cartridge door assembly

 **Reinstallation tip:** After a replacement door is installed, make sure to install the nameplate (supplied in the kit) corresponding to the printer name on the door.

- Position the door close to the printer, and then engage the keyed pin on the left-side retainer arm with the hole in the door.

Figure 1-396 Engage the left-side retainer arm

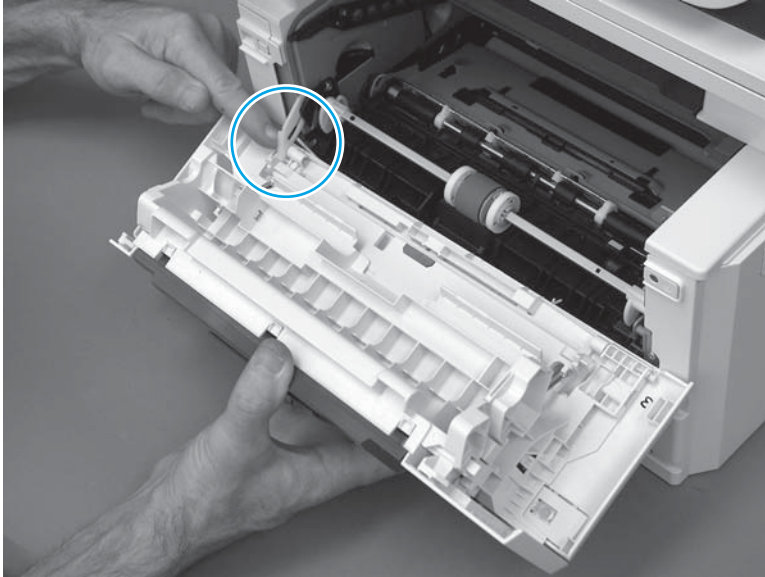

2. Engage the right-side door hinge pin with the hole in the chassis (callout 1).

Figure 1-397 Install the door

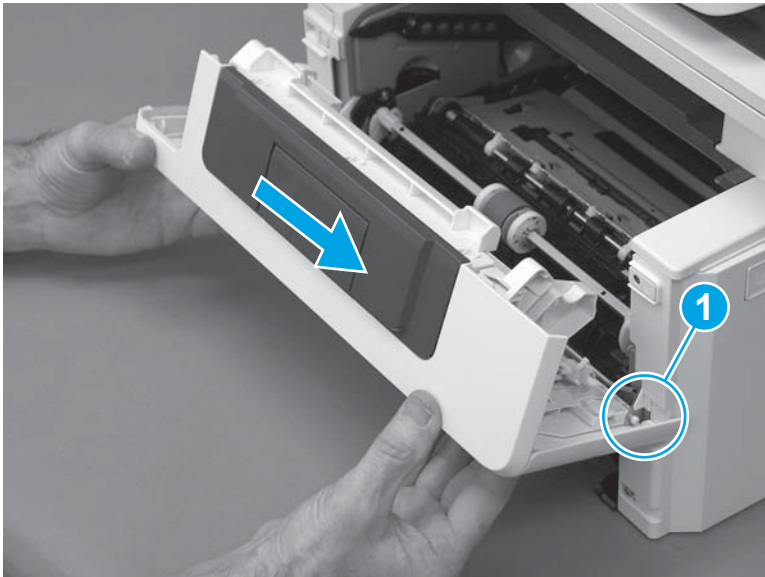

3. Install the link (callout 1).

 **IMPORTANT:** Make sure that the link snaps into place on the arm (callout 2). The link actuates the fuser pressure-release mechanism.

Figure 1-398 Install the pressure-release link

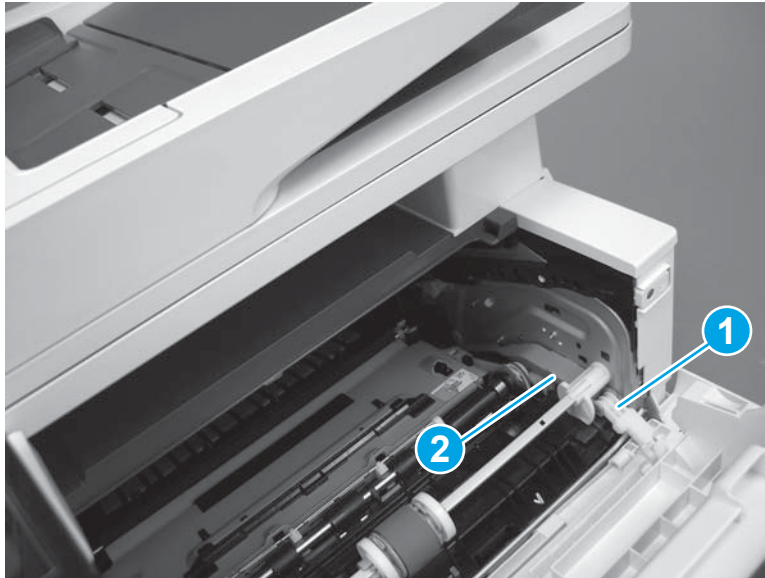

4. Slide the guide into the printer (callout 1), and then make sure that the tab (callout 2) snaps into place to secure the guide to the chassis.

Figure 1-399 Install the guide

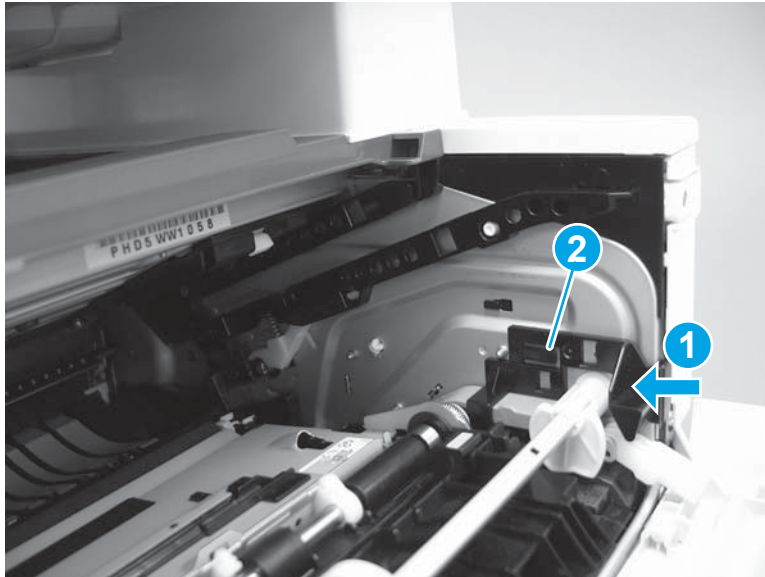

5. Position the shaft on the door, and then align the left-side hinge on the door with the hole in the chassis (callout 1).

Figure 1-400 Align the hinge

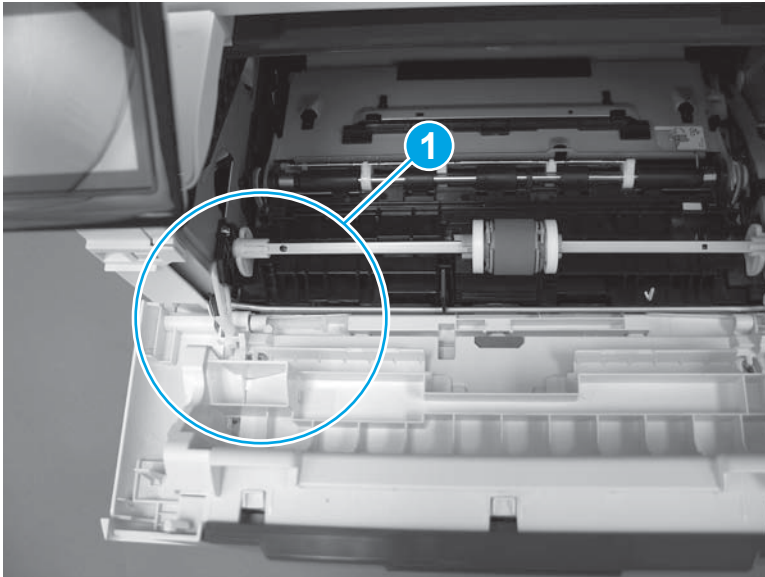

6. Push the shaft towards the left side of the printer to install it (callout 1).

 **Reinstallation tip:** Make sure that the support shaft is fully installed and correctly orientated (callout 2) so that it will not interfere with the door opening and closing.

Figure 1-401 Install the support shaft



Step 13: Install Tray 2

- ▲ Slide the tray straight into the printer to install it.

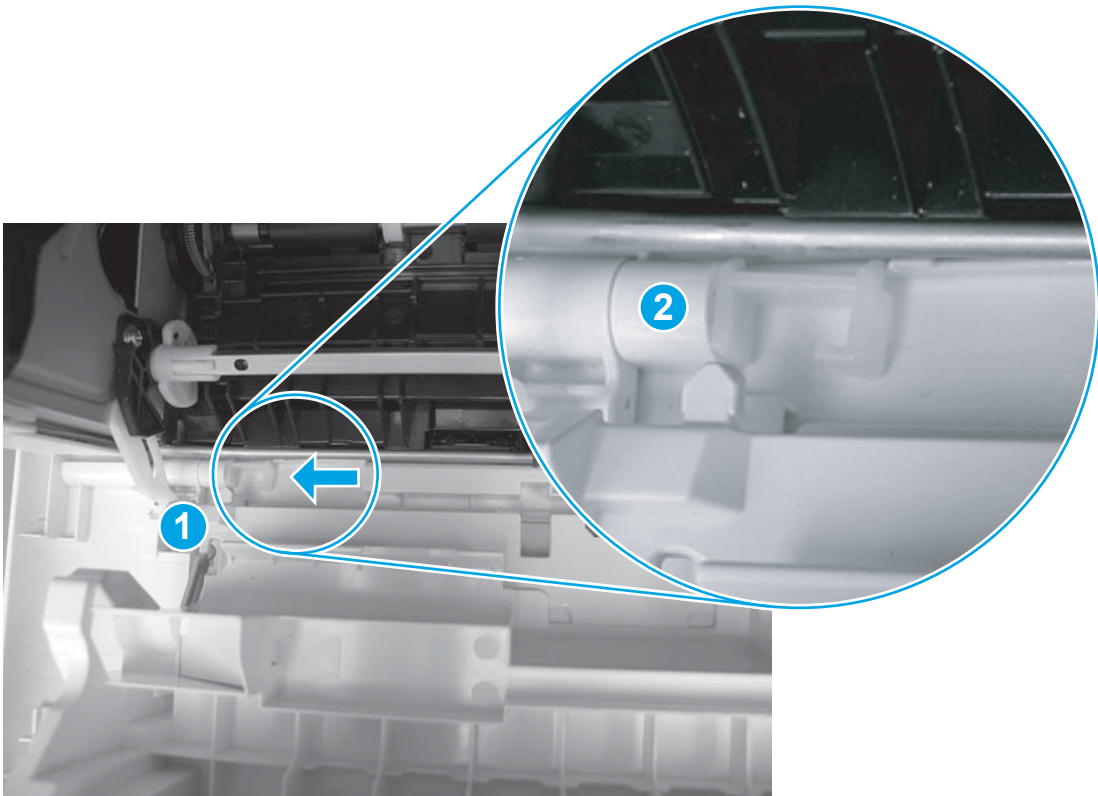
Figure 1-402 Install the tray



Removal and replacement: 2-line LCD operator and indication covers (M403/M402)

- [Introduction](#)
- [Step 1: Remove Tray 2](#)
- [Step 2: Remove the cartridge door assembly](#)
- [Step 3: Remove the left cover](#)
- [Step 4: Remove the right cover](#)
- [Step 5: Remove the top cover \(M403/M402\)](#)
- [Step 6: Remove the 2-line LCD operator and indication covers \(M403/M402\)](#)
- [Step 7: Unpack the replacement assembly](#)
- [Step 8: Install the 2-line LCD operator and indication covers \(M403/M402\)](#)
- [Step 9: Install the top cover \(M403/M402\)](#)
- [Step 10: Install the right cover](#)
- [Step 11: Install the left cover](#)
- [Step 12: Install the cartridge door assembly](#)
- [Step 13: Install Tray 2](#)

Introduction

This document provides the procedures to remove and replace the 2-line LCD operator and indication covers.

Before performing service

Turn the printer power off

- Disconnect the power cable.

 **WARNING!** To avoid damage to the printer, turn the printer off, wait 30 seconds, and then remove the power cable before attempting to service the printer.

Use the table below to identify the correct part number for your printer. To order the part, go to www.hp.com/buy/parts.

2-line LCD operator and indication covers (M403/M402) part number	
RC4-3312-000CN	2-line LCD operator cover (M403/M402; non-wireless models)
RC4-3322-000CN	2-line LCD operator cover (M402dw; wireless model)
RL2-0675-000CN	2-line LCD indication cover (M403/M402)

Required tools

- #2 Phillips screwdriver with a magnetic tip.

After performing service

Turn the printer power on

- Connect the power cable.
- Use the power switch to turn the power on.

Post service test

Make sure that the printer initializes to a **Ready** state.

Print a configuration page to make sure that the printer is functioning correctly.

Step 1: Remove Tray 2

- ▲ Pull the tray straight out of the printer to remove it.

Figure 1-403 Remove the tray



Step 2: Remove the cartridge door assembly



NOTE: If the toner cartridge was not removed prior to servicing the printer, remove it now.

1. Release one tab (callout 1), and then slide shaft (callout 2) in the direction the arrow indicates and remove it.



TIP: It might be easier to release the support shaft by using a small flat-blade screwdriver.

Figure 1-404 Release the support shaft

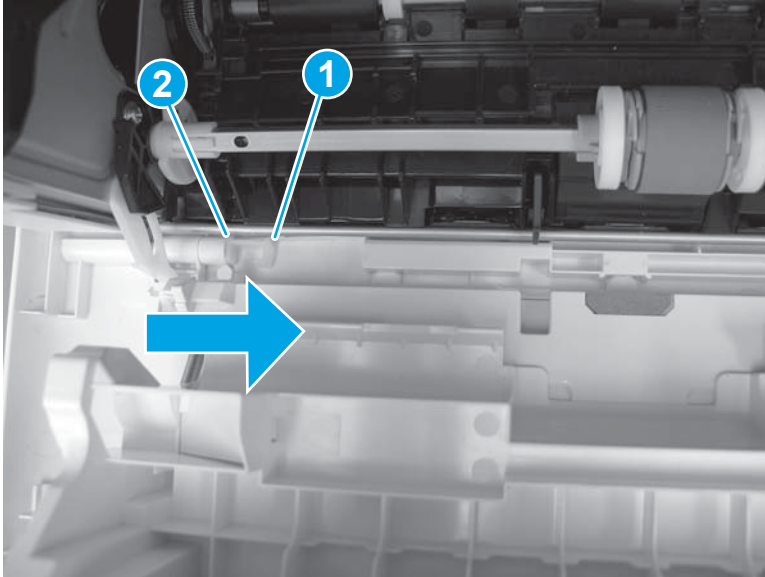

2. Release one tab (callout 1), and then slide the guide (callout 2) in the direction the arrow indicates and remove it.

Figure 1-405 Remove the guide

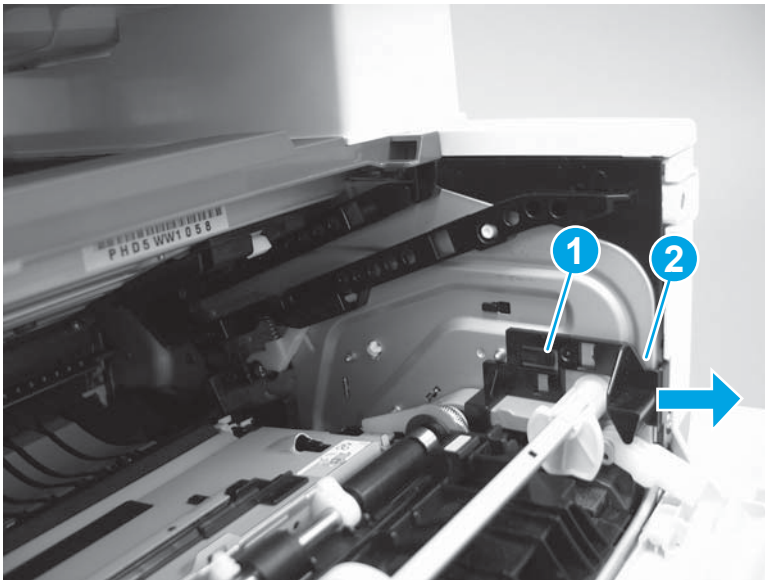

3. Remove the link arm (callout 1).

Figure 1-406 Remove the link arm

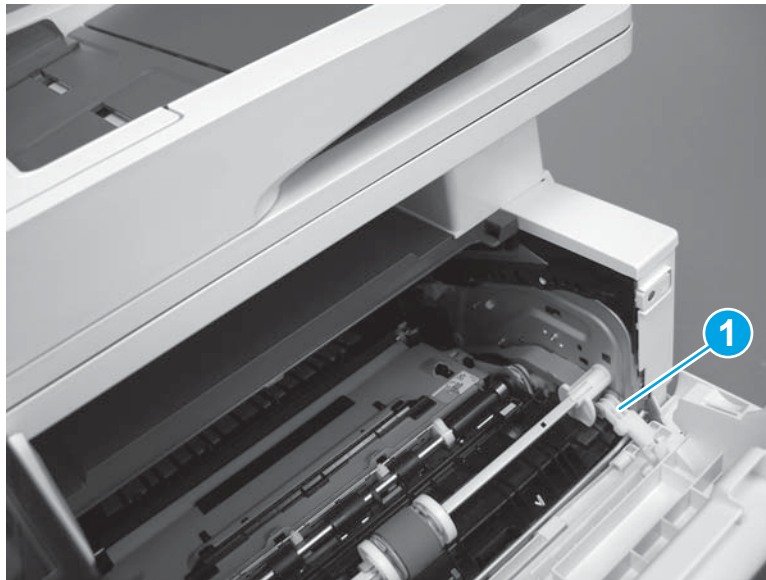

4. Slide the cartridge door assembly (callout 1) in the direction the arrow indicates and remove it.

Figure 1-407 Remove the door

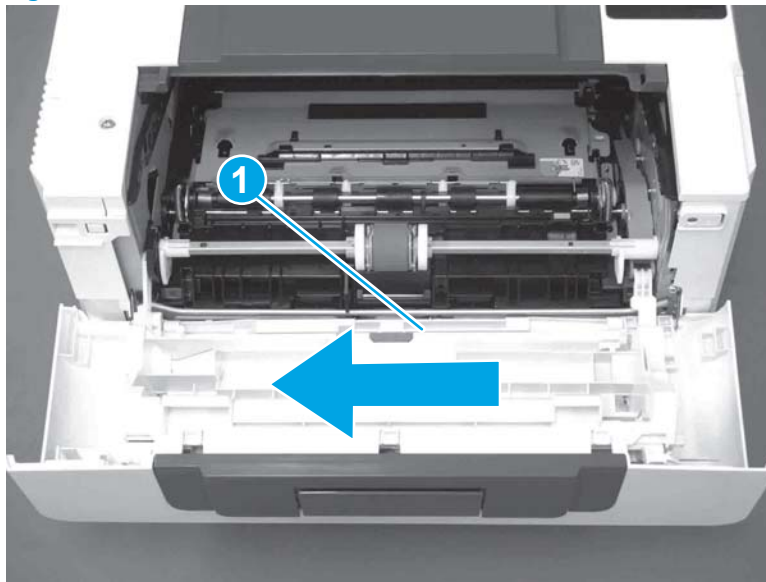

5. Remove the link (callout 1) from the cartridge door assembly (callout 2).

Figure 1-408 Release the left-side retainer arm

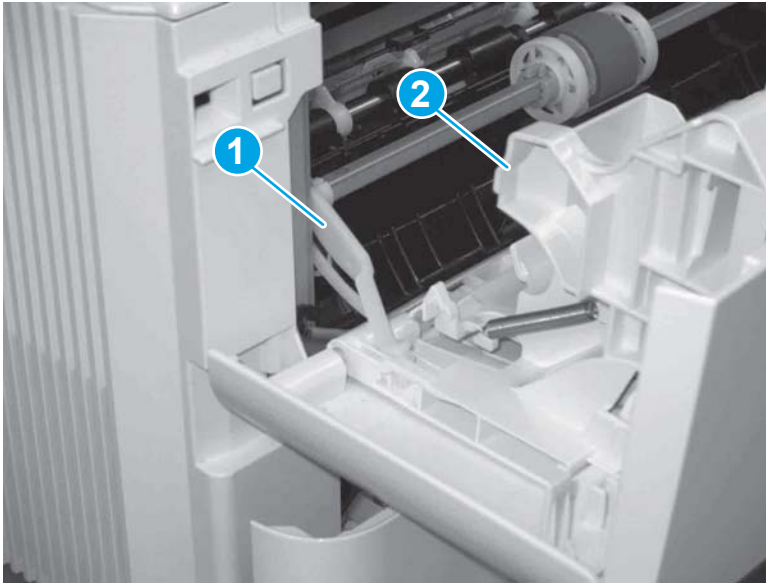

Step 3: Remove the left cover

1. Remove one screw (callout 1).

Figure 1-409 Remove one screw

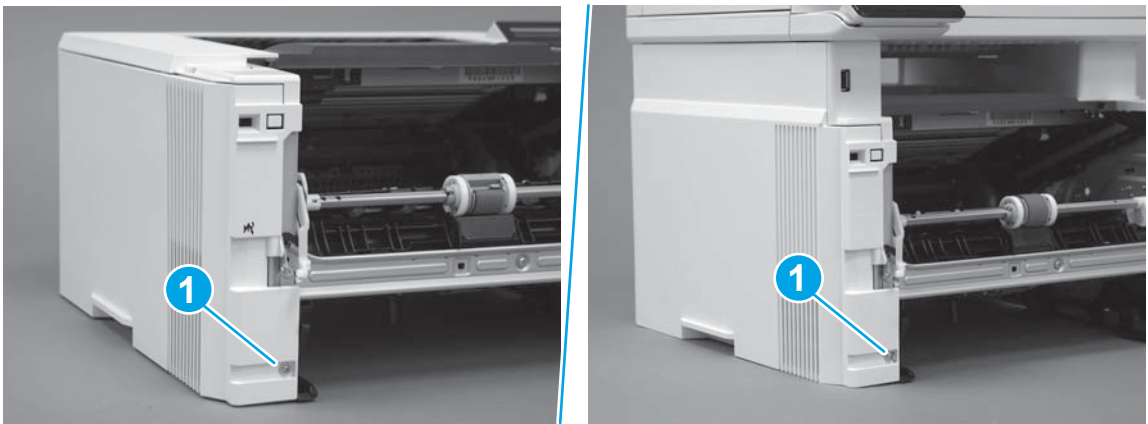

2. Open the rear door, release two bosses (callout 1), and then release three tabs (callout 2).

Figure 1-410 Release two bosses and three tabs

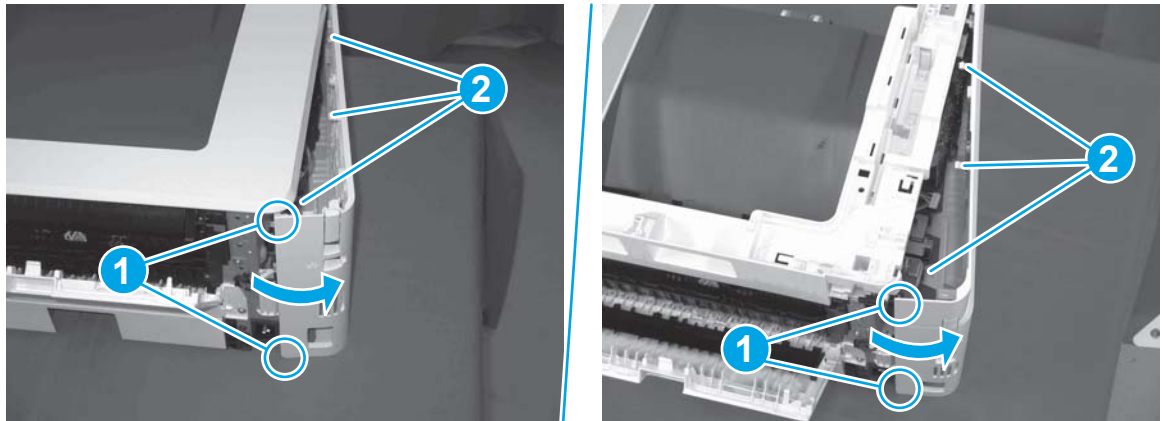

3. At the front of the printer, do one of the following:
 - **M403/M402:** Release two bosses (callout 1), and then remove the cover (callout 2).
 - **M427/M426:** Release one tab (callout 3), two bosses (callout 4), and then remove the cover (callout 5).

CAUTION: Be careful when releasing the upper bosses on the M427/M426 cover. One portion of the cover (callout 6) is fragile and is easily broken.

Figure 1-411 Remove the cover

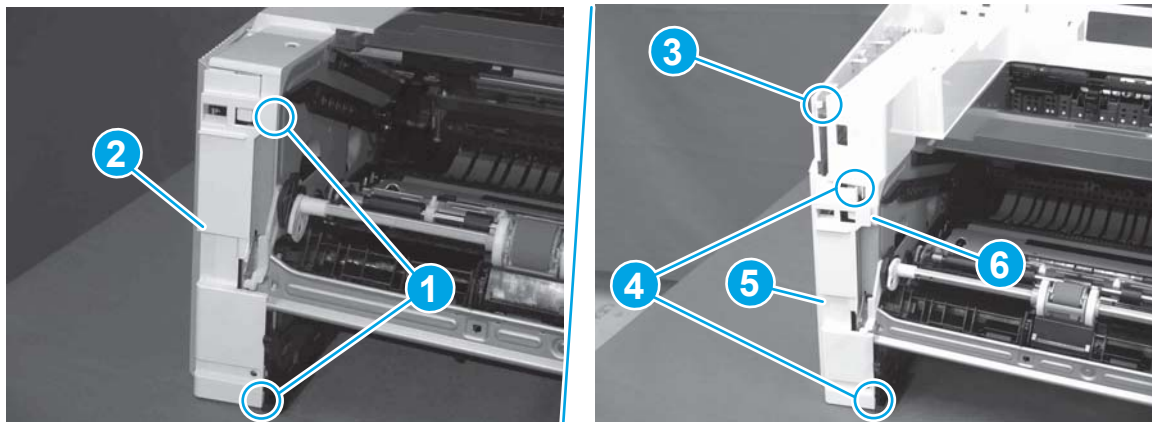

Step 4: Remove the right cover

1. Remove one screw (callout 1).

Figure 1-412 Remove one screw

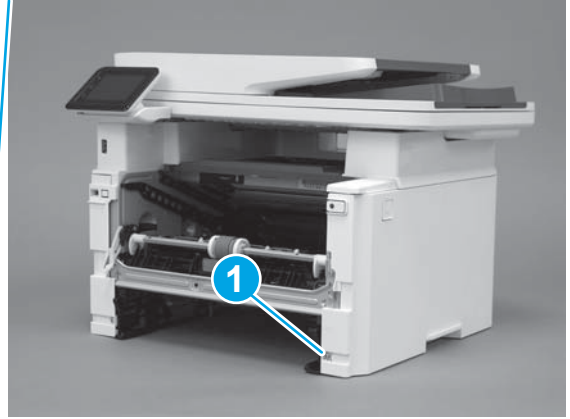
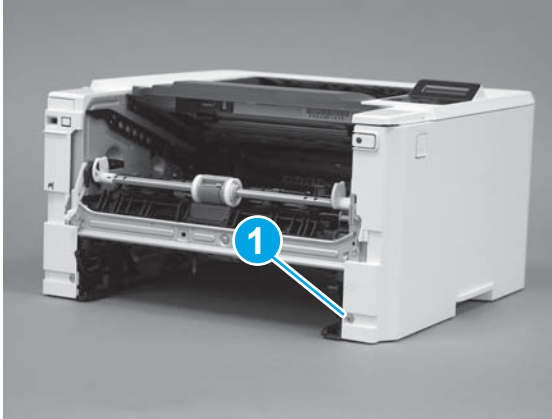

2. At the front of the printer, release two bosses (callout 1), and then release three tabs (callout 2).

Figure 1-413 Release two bosses and three tabs

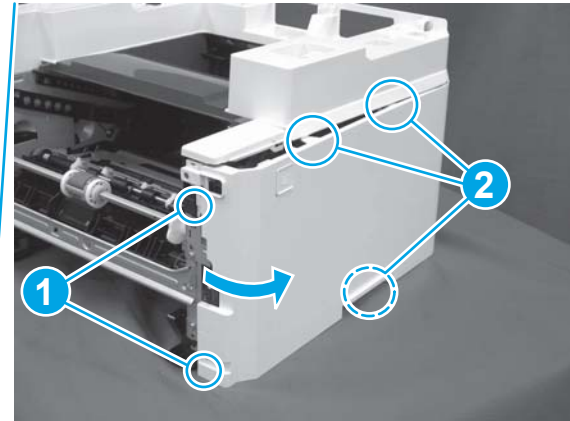
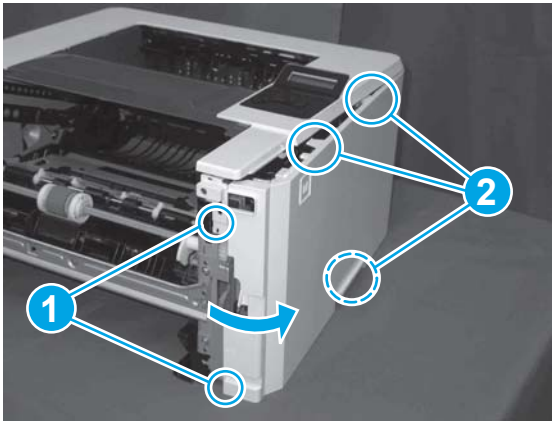

3. Open the rear door, release two bosses (callout 1), and then remove the cover (callout 2).

Figure 1-414 Remove the cover

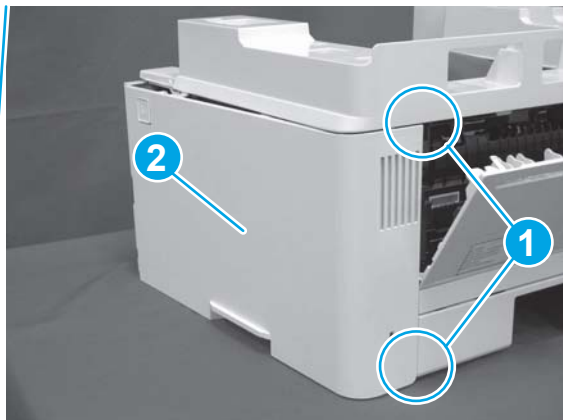
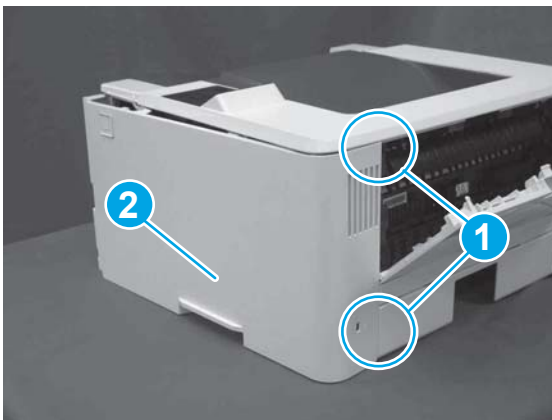

Step 5: Remove the top cover (M403/M402)

1. Remove one screw (callout 1).

Figure 1-415 Remove one screw



2. At the right side of the printer, release the one boss (callout 1), and then release one tab (callout 2).

Figure 1-416 Release one boss and one tab

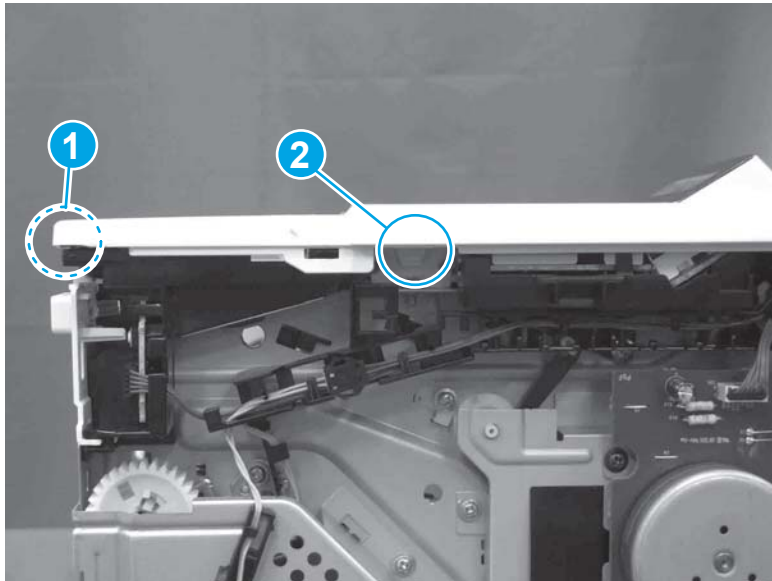

3. Release four tabs (callout 1), release four bosses (callout 2), and then remove the top cover (callout 3).

 **TIP:** Open the rear door to make releasing the bosses (callout 3) easier.

Figure 1-417 Remove the cover



Step 6: Remove the 2-line LCD operator and indication covers (M403/M402)

1. Rotate the top edge of the operator cover away from the printer to release it.

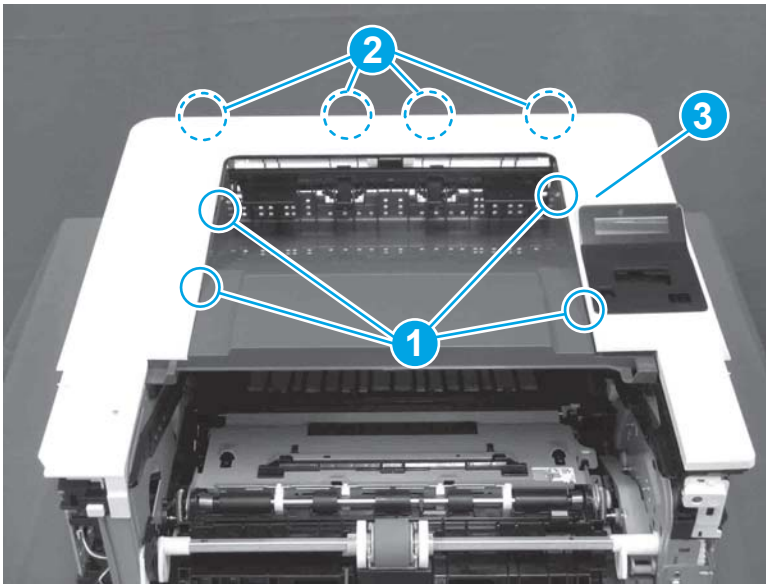
Figure 1-418 Rotate the top edge of the operator cover

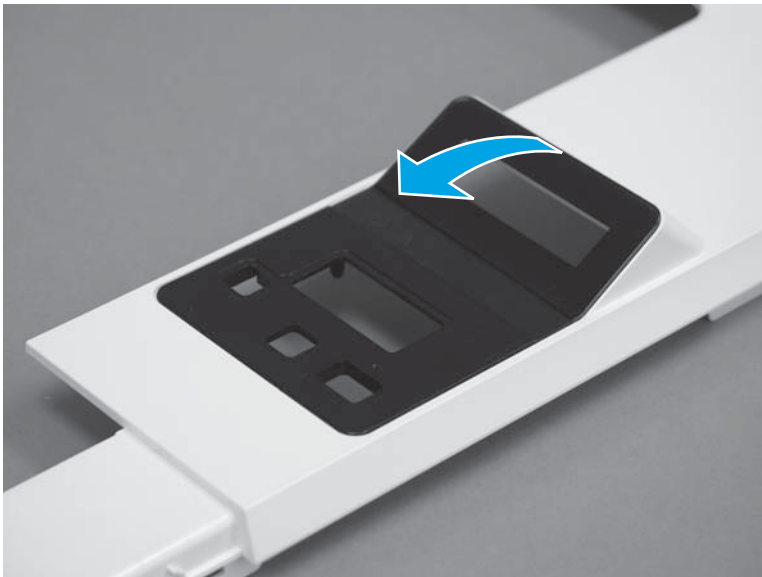

2. Remove the operator cover.

Figure 1-419 Remove the cover



3. Turn the top cover over, release two tabs (callout 1), and then remove the indication cover.

Figure 1-420 Remove the cover

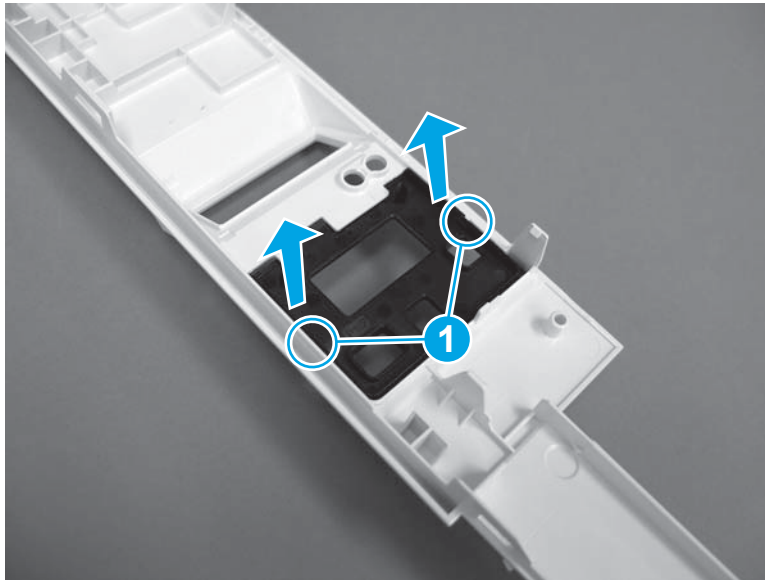

Step 7: Unpack the replacement assembly

Unpack the replacement part from the packaging.

<http://www8.hp.com/us/en/hp-information/environment/product-recycling.html>

 **NOTE:** HP recommends responsible disposal of the defective part.

Figure 1-421 Recycle and unpack

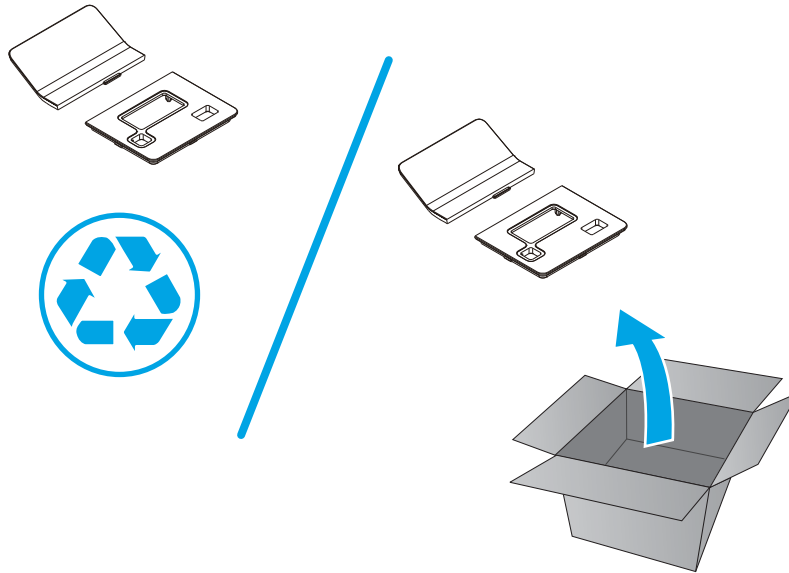

Step 8: Install the 2-line LCD operator and indication covers (M403/M402)

1. Position the indication cover on the top cover, and then make sure that the two tabs (callout 1) snap into place.

Figure 1-422 Install the cover

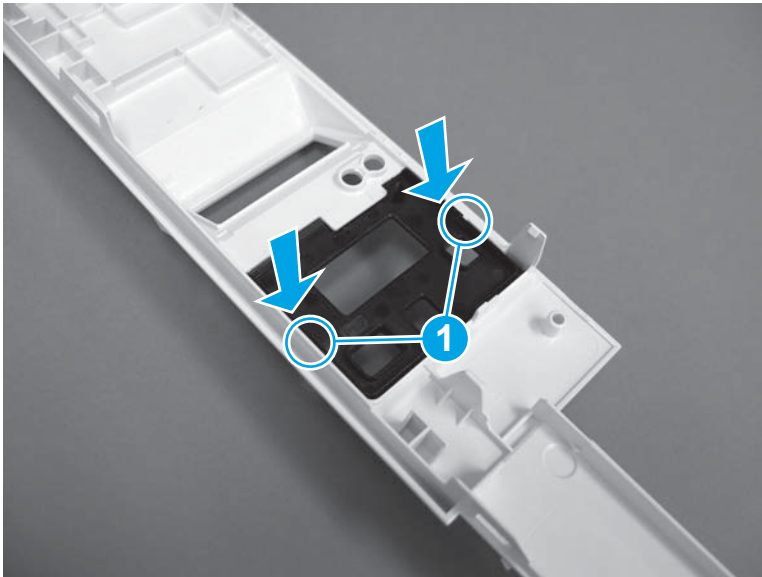

2. Turn the top cover over, and then position the bottom edge of the operator cover with the tab (callout 1) under the indication cover (callout 2).

Figure 1-423 Position the operator cover on the printer



3. Rotate the top edge of the cover towards from the printer to install it.

 **Reinstallation tip:** Use two-sided tape to secure the upper edge of the operator cover to the top cover.

Figure 1-424 Install the cover



Step 9: Install the top cover (M403/M402)

1. Position the rear edge of the cover on the printer.

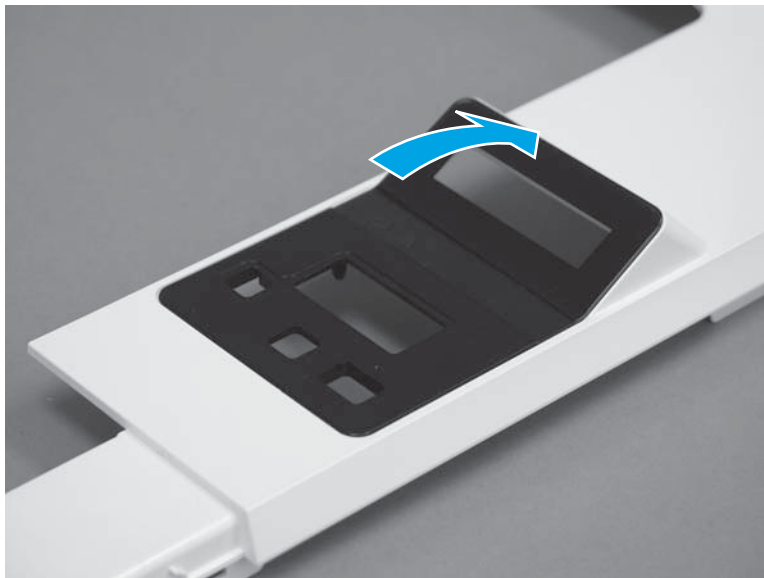
Figure 1-425 Install the cover

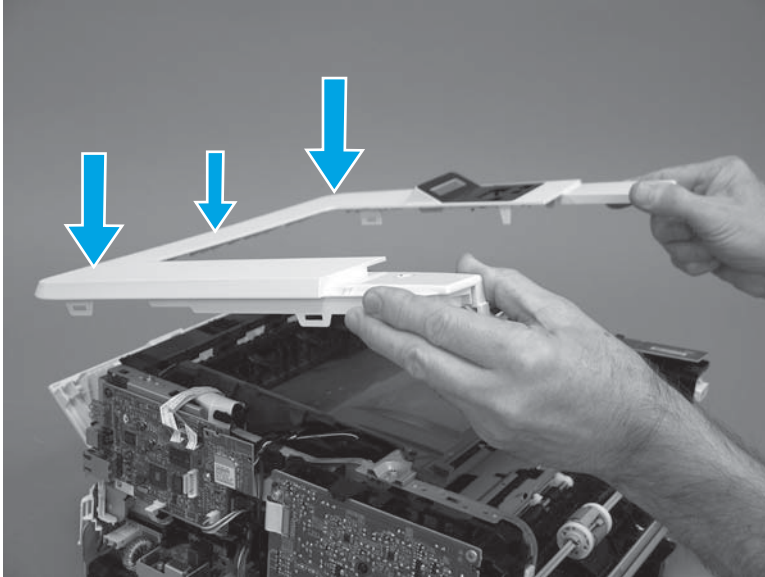

2. Engage four bosses (callout 1), rotate the front of the cover down (callout 2) and onto from the printer, and then engage four tabs (callout 3).

Figure 1-426 Engage four bosses and tabs

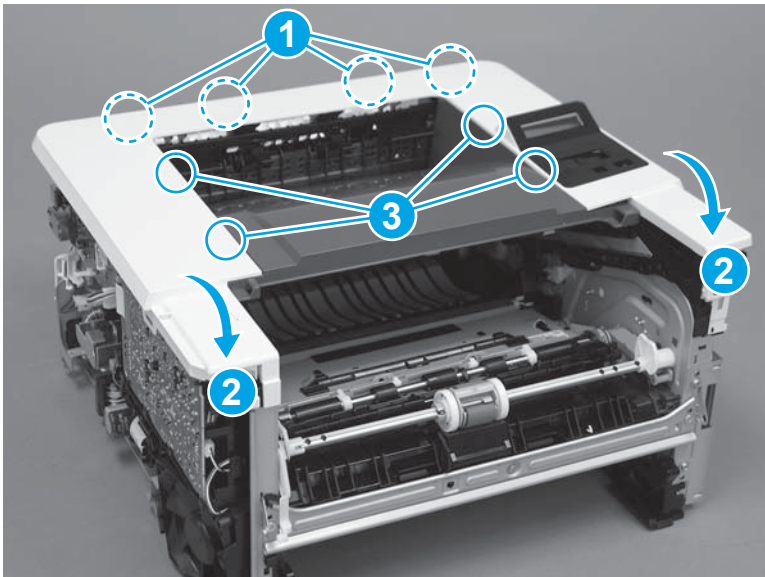

3. At the right side of the printer, engage the one boss and one tab (callout 1).

Figure 1-427 Engage one boss and one tab

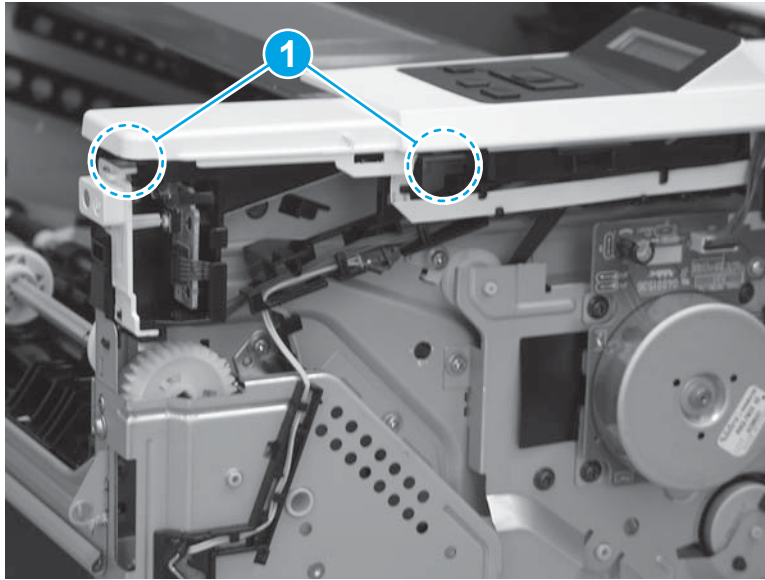

4. Install one screw (callout 1).

Figure 1-428 Install one screw



Step 10: Install the right cover

1. Position the cover (callout 1) on the printer, and then engage two bosses (callout 2).

Figure 1-429 Install the cover

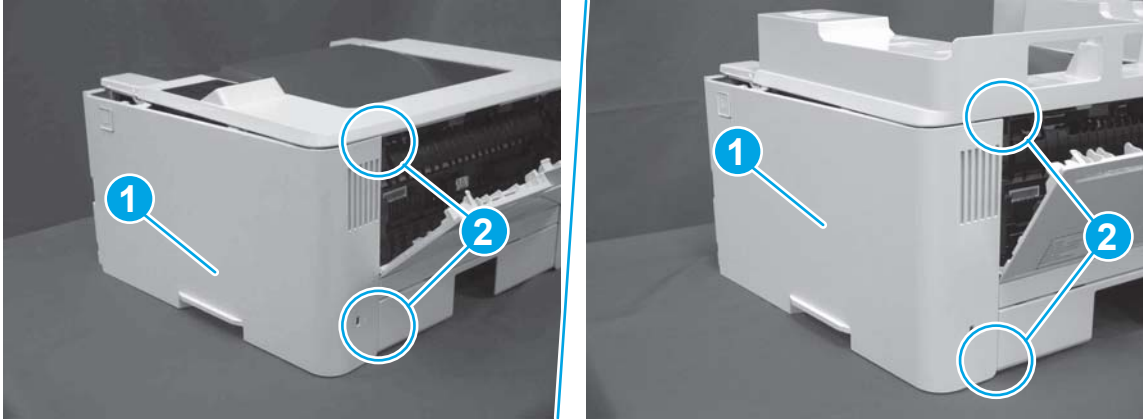

2. Rotate the front of the cover onto the printer (callout 1), engage three (callout 2) tabs, and then engage two bosses (callout 3).

Figure 1-430 Engage two bosses and one tab

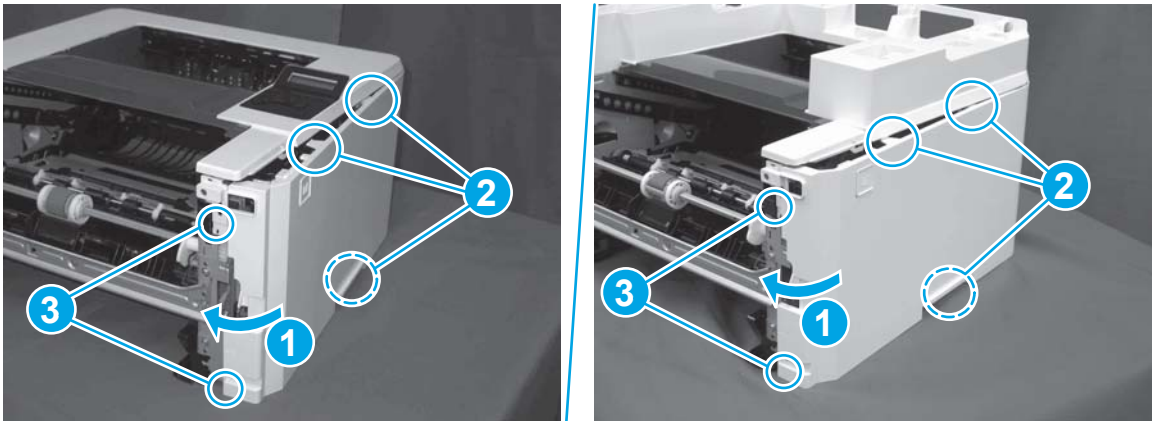

3. Make sure that the power switch (callout 1) and cartridge door assembly button (callout 2) correctly function.

 **NOTE:** Remove, and then reinstall the cover if the switch or button does not correctly function.

Figure 1-431 Check the power switch and cartridge door assembly button



4. Install one screw (callout 1).

Figure 1-432 Install one screw

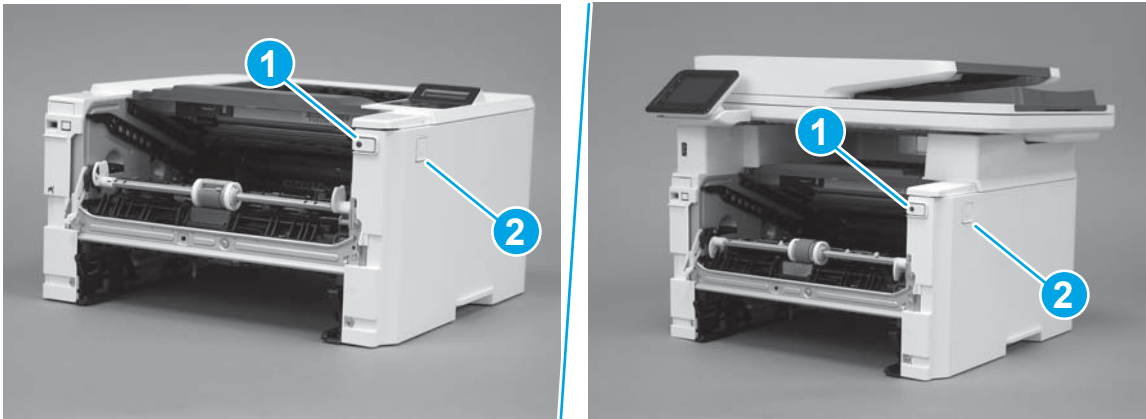

Step 11: Install the left cover

1. At the front of the printer, do one of the following:
 - **M403/M402:** Position the cover on the printer (callout 1), and then engage two bosses (callout 2).
 - **M427/M426:** Position the cover on the printer (callout 3), engage one tab (callout 4), and then engage two bosses (callout 4).

Figure 1-433 Install the cover

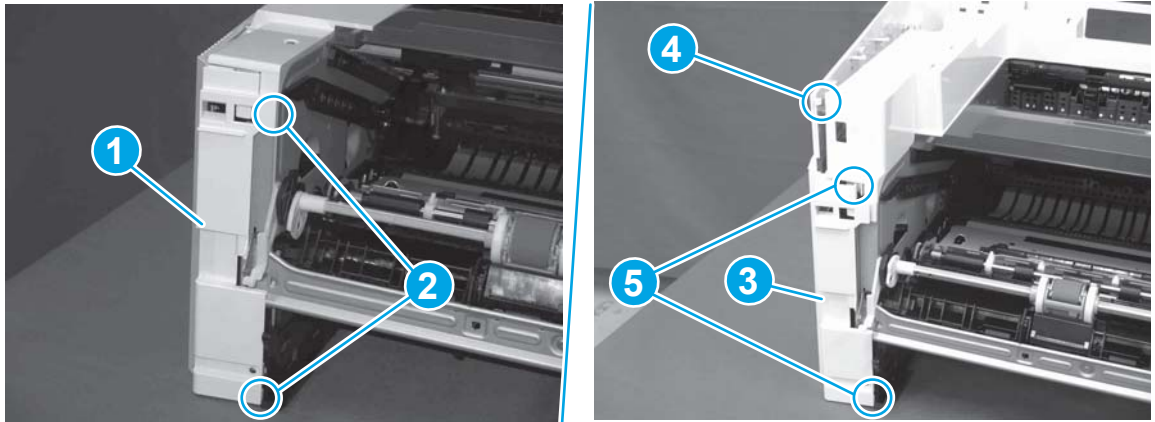

- Carefully rotate the rear of the cover onto the printer (callout 1), engage three tabs (callout 2), and then engage two bosses (callout 3).

Figure 1-434 Engage three tabs and two bosses

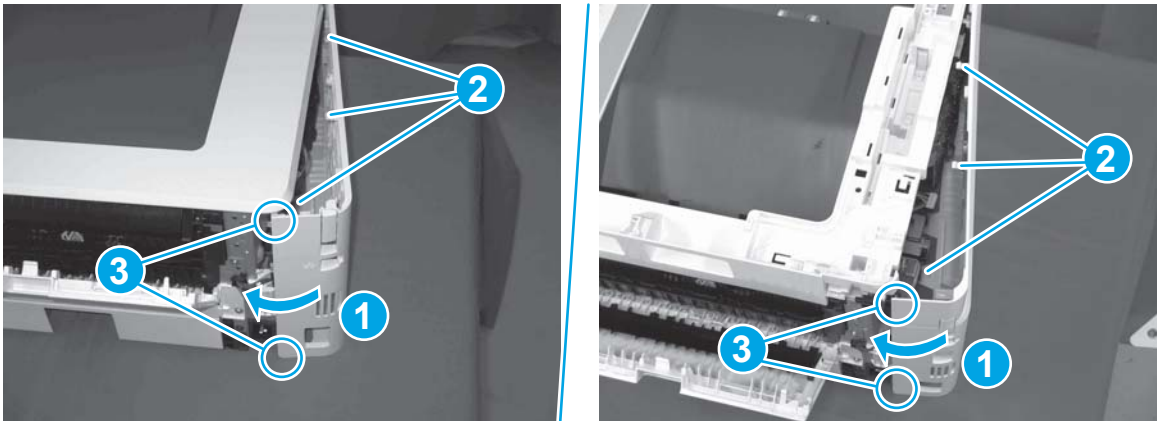

- Install one screw (callout 1).

Figure 1-435 Install one screw

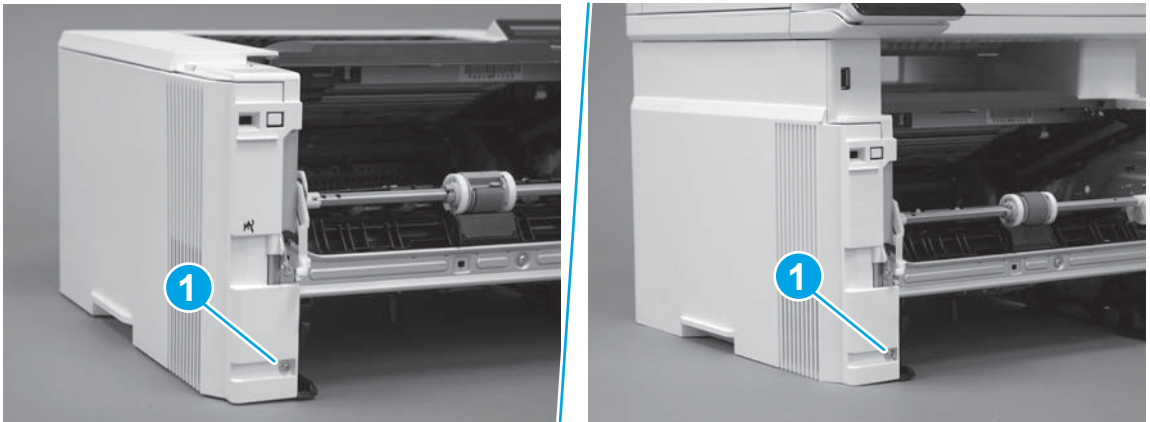

Step 12: Install the cartridge door assembly

 **Reinstallation tip:** After a replacement door is installed, make sure to install the nameplate (supplied in the kit) corresponding to the printer name on the door.

- Position the door close to the printer, and then engage the keyed pin on the left-side retainer arm with the hole in the door.

Figure 1-436 Engage the left-side retainer arm

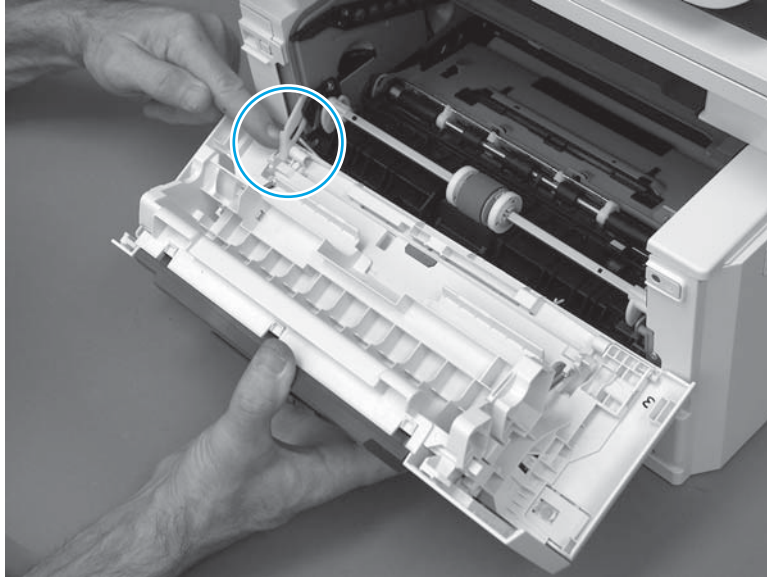

2. Engage the right-side door hinge pin with the hole in the chassis (callout 1).

Figure 1-437 Install the door

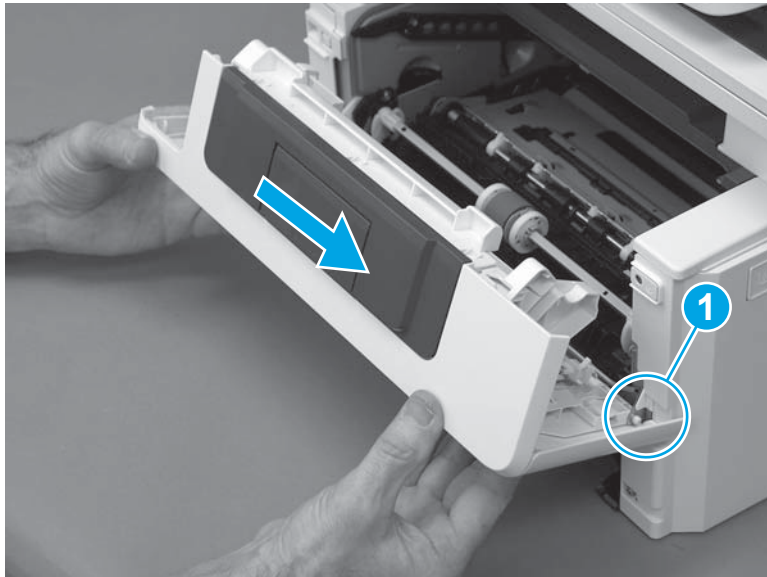

3. Install the link (callout 1).

 **IMPORTANT:** Make sure that the link snaps into place on the arm (callout 2). The link actuates the fuser pressure-release mechanism.

Figure 1-438 Install the pressure-release link

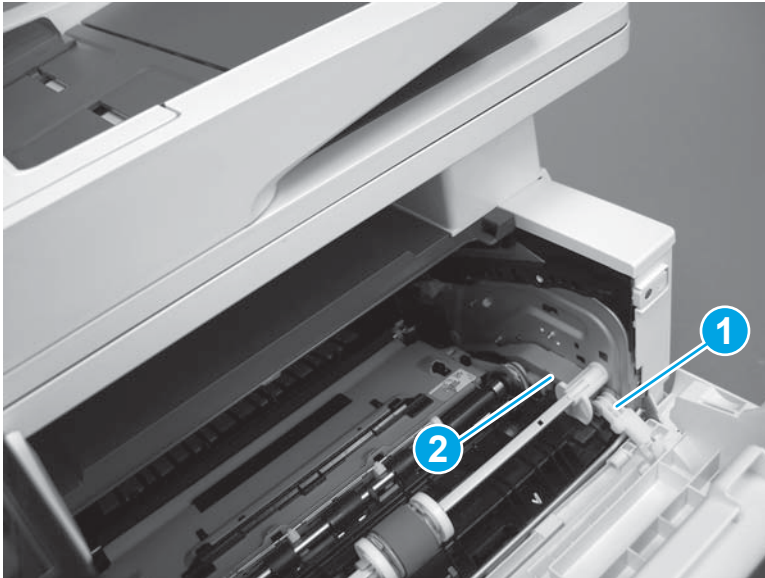

4. Slide the guide into the printer (callout 1), and then make sure that the tab (callout 2) snaps into place to secure the guide to the chassis.

Figure 1-439 Install the guide

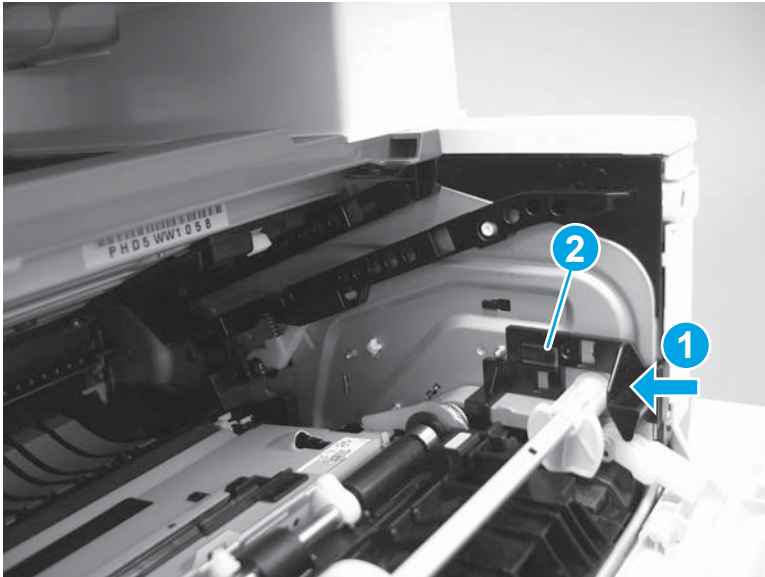

5. Position the shaft on the door, and then align the left-side hinge on the door with the hole in the chassis (callout 1).

Figure 1-440 Align the hinge

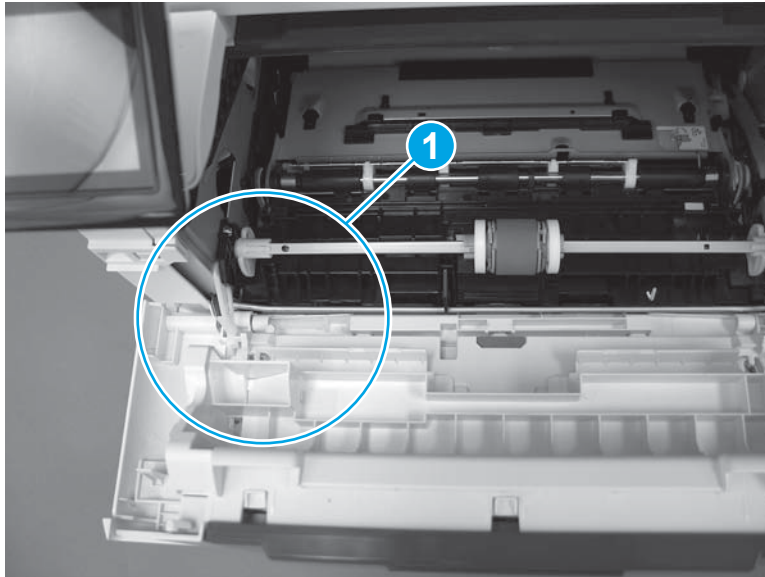

6. Push the shaft towards the left side of the printer to install it (callout 1).

 **Reinstallation tip:** Make sure that the support shaft is fully installed and correctly orientated (callout 2) so that it will not interfere with the door opening and closing.

Figure 1-441 Install the support shaft



Step 13: Install Tray 2

- ▲ Slide the tray straight into the printer to install it.

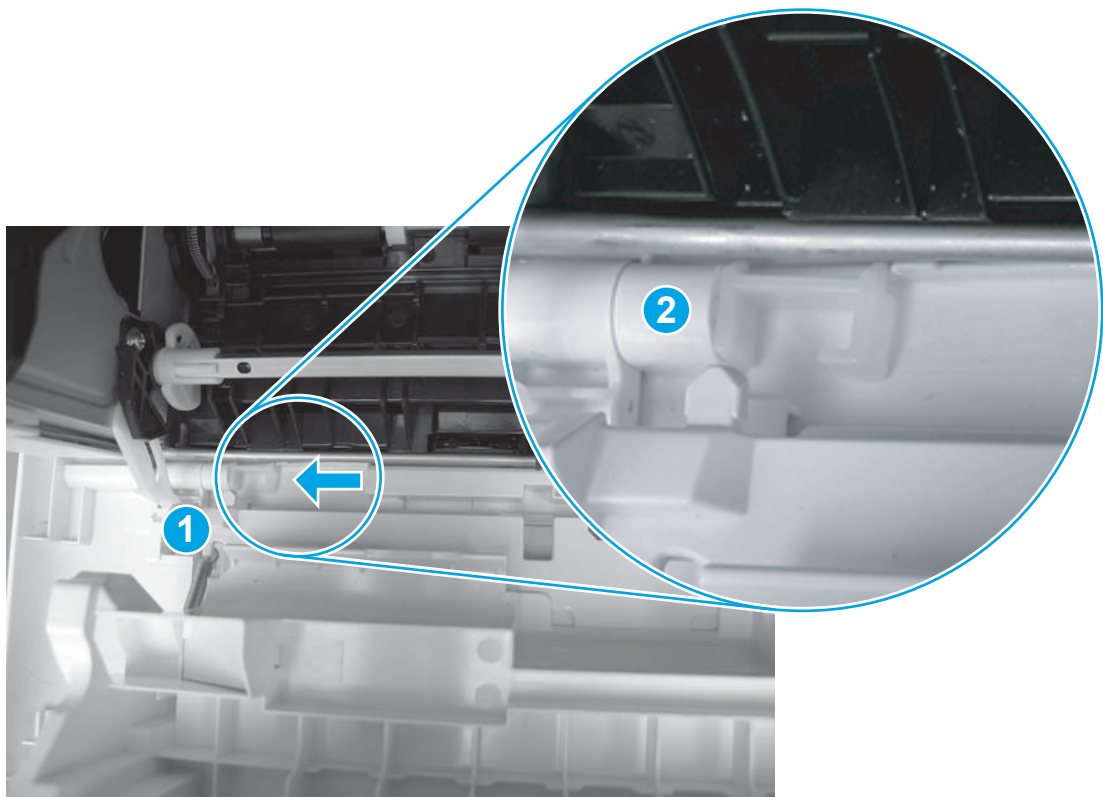
Figure 1-442 Install the tray



Removal and replacement: Paper delivery tray (output bin)

- [Introduction](#)
- [Step 1: Remove Tray 2](#)
- [Step 2: Remove the cartridge door assembly](#)
- [Step 3: Remove the left cover](#)
- [Step 4: Remove the right cover](#)
- [Step 5: Remove the integrated scanner assembly \(M427/M246\)](#)
- [Step 6: Remove the control panel \(M427/M246\)](#)
- [Step 7: Remove the top cover \(M427/M426\)](#)
- [Step 8: Remove the top cover \(M403/M402\)](#)
- [Step 9: Remove the paper delivery tray \(output bin\)](#)
- [Step 10: Unpack the replacement assembly](#)
- [Step 11: Install the paper delivery tray \(output bin\)](#)
- [Step 12: Install the top cover \(M403/M402\)](#)
- [Step 13: Install the top cover \(M427/M426\)](#)
- [Step 14: Install the control panel \(M427/M246\)](#)
- [Step 15: Install the integrated scanner assembly \(M427/M246\)](#)
- [Step 16: Install the right cover](#)
- [Step 17: Install the left cover](#)
- [Step 18: Install the cartridge door assembly](#)
- [Step 19: Install Tray 2](#)

Introduction

This document provides the procedures to remove and replace the paper delivery tray (output bin).

Before performing service

Turn the printer power off

- Disconnect the power cable.

 **WARNING!** To avoid damage to the printer, turn the printer off, wait 30 seconds, and then remove the power cable before attempting to service the printer.

Use the table below to identify the correct part number for your printer. To order the part, go to www.hp.com/buy/parts.

Paper delivery tray (output bin) part number

RC4-3231-000CNPaper delivery tray (output bin)

Required tools

- #2 Phillips screwdriver with a magnetic tip.
- Small flat-blade screwdriver (M427/M426 required; M403/M402 optional)

After performing service**Turn the printer power on**

- Connect the power cable.
- Use the power switch to turn the power on.

Post service test

Make sure that the printer initializes to a **Ready** state.

Print a configuration page to make sure that the printer is functioning correctly.

Step 1: Remove Tray 2

- ▲ Pull the tray straight out of the printer to remove it.

Figure 1-443 Remove the tray

Step 2: Remove the cartridge door assembly

 **NOTE:** If the toner cartridge was not removed prior to servicing the printer, remove it now.

1. Release one tab (callout 1), and then slide shaft (callout 2) in the direction the arrow indicates and remove it.

 **TIP:** It might be easier to release the support shaft by using a small flat-blade screwdriver.

Figure 1-444 Release the support shaft

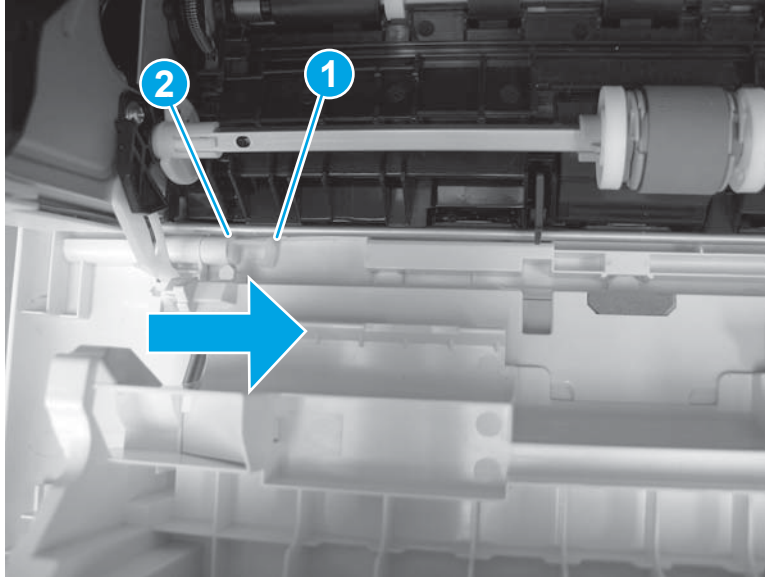

2. Release one tab (callout 1), and then slide the guide (callout 2) in the direction the arrow indicates and remove it.

Figure 1-445 Remove the guide

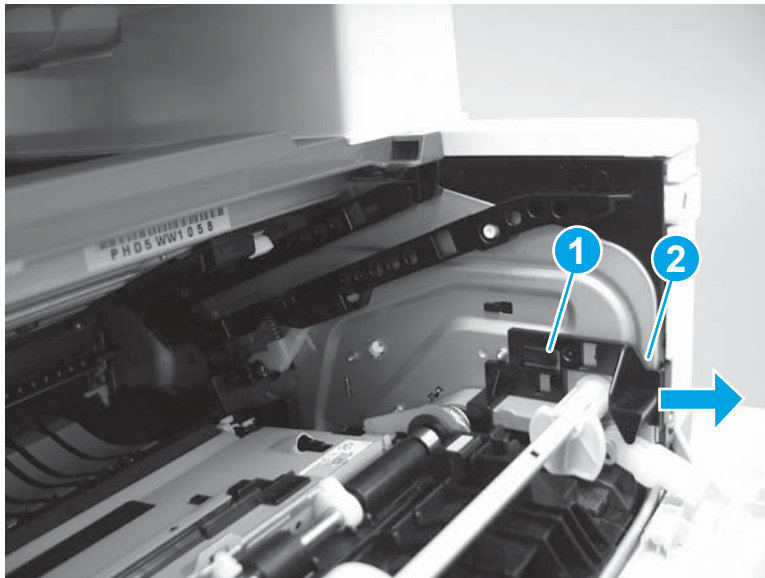

3. Remove the link arm (callout 1).

Figure 1-446 Remove the link arm

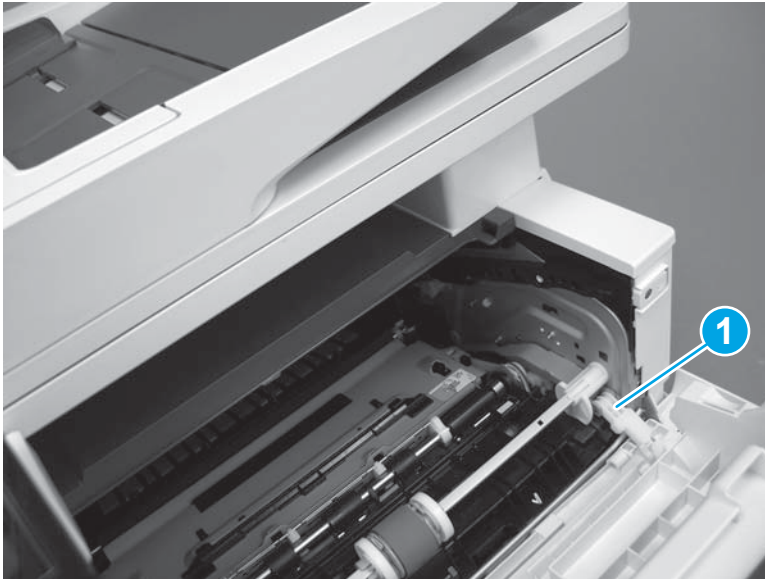

4. Slide the cartridge door assembly (callout 1) in the direction the arrow indicates and remove it.

Figure 1-447 Remove the door

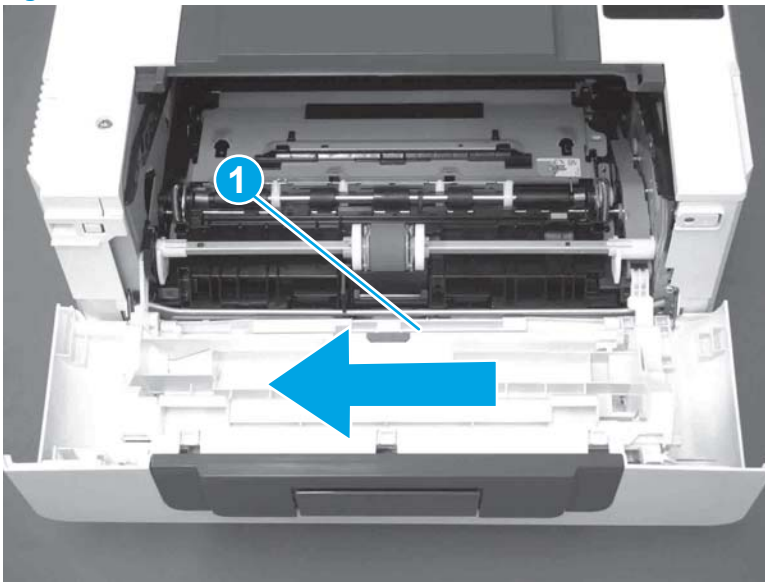

5. Remove the link (callout 1) from the cartridge door assembly (callout 2).

Figure 1-448 Release the left-side retainer arm

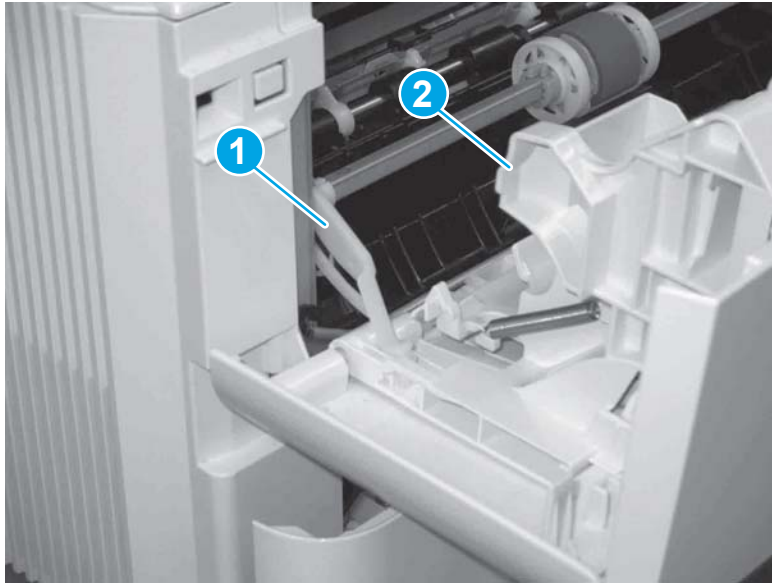

Step 3: Remove the left cover

1. Remove one screw (callout 1).

Figure 1-449 Remove one screw

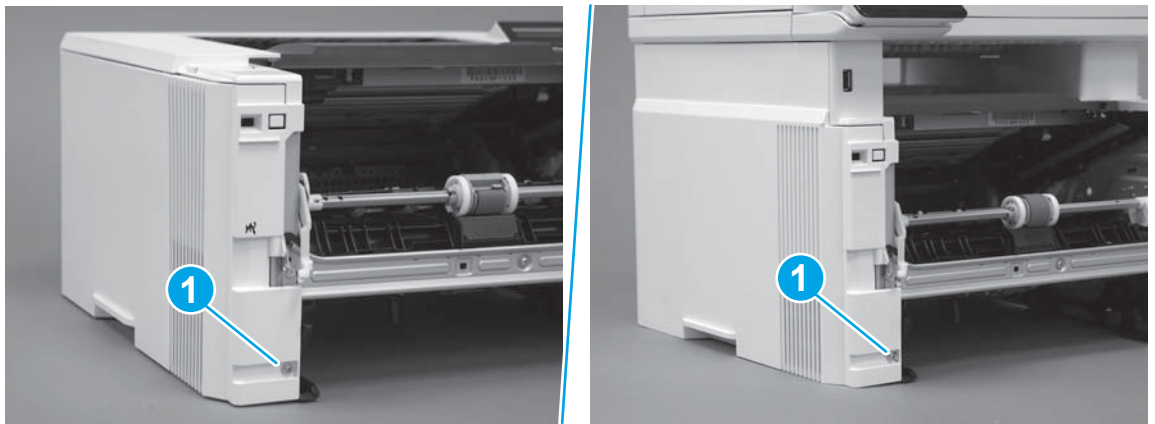

2. Open the rear door, release two bosses (callout 1), and then release three tabs (callout 2).

Figure 1-450 Release two bosses and three tabs

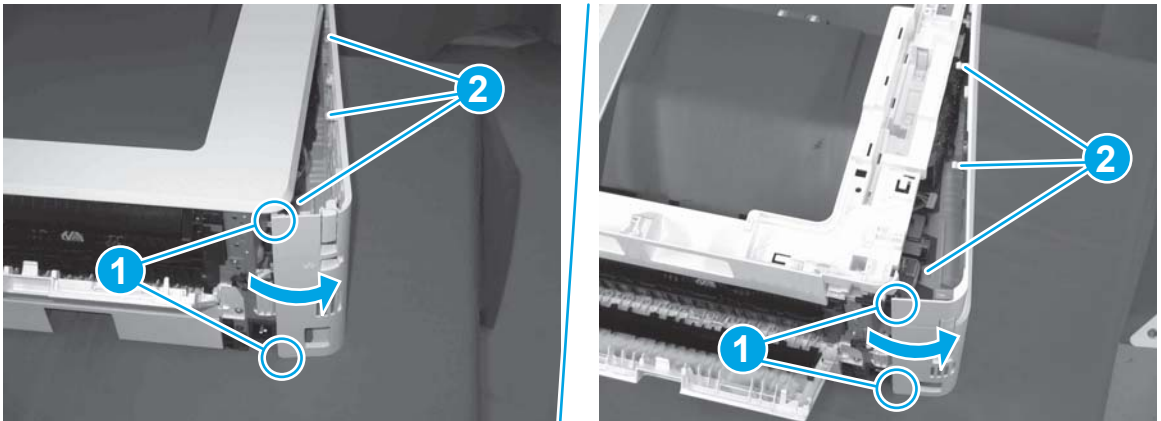

3. At the front of the printer, do one of the following:
 - **M403/M402:** Release two bosses (callout 1), and then remove the cover (callout 2).
 - **M427/M426:** Release one tab (callout 3), two bosses (callout 4), and then remove the cover (callout 5).

CAUTION: Be careful when releasing the upper bosses on the M427/M426 cover. One portion of the cover (callout 6) is fragile and is easily broken.

Figure 1-451 Remove the cover

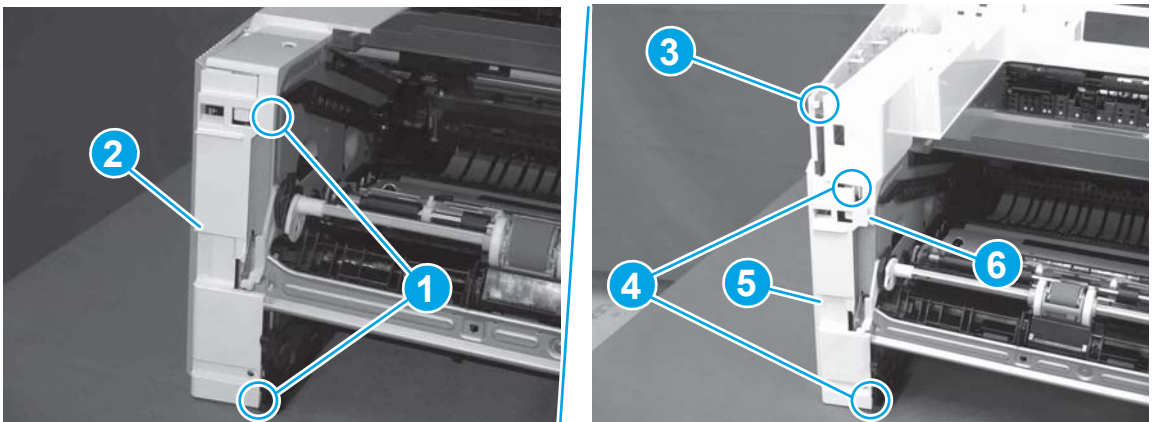

Step 4: Remove the right cover

1. Remove one screw (callout 1).

Figure 1-452 Remove one screw



2. At the front of the printer, release two bosses (callout 1), and then release three tabs (callout 2).

Figure 1-453 Release two bosses and three tabs

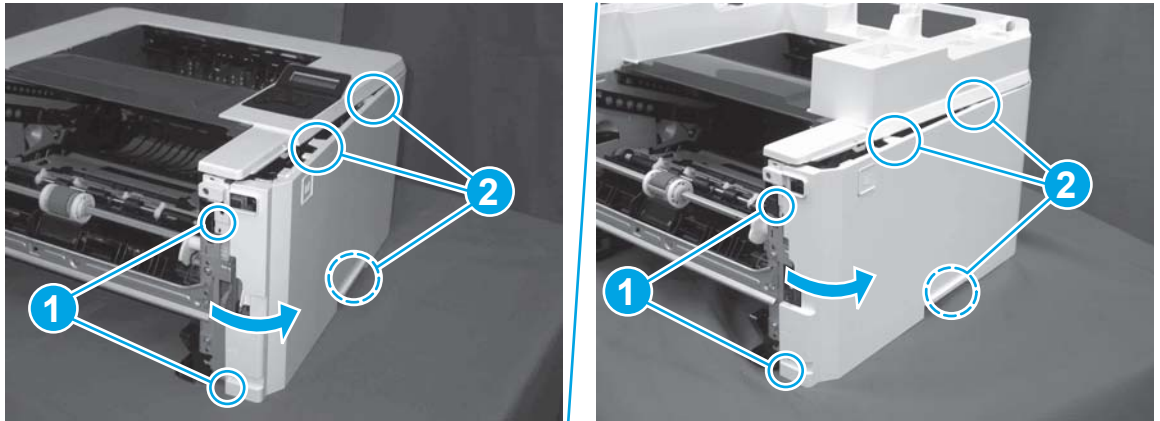

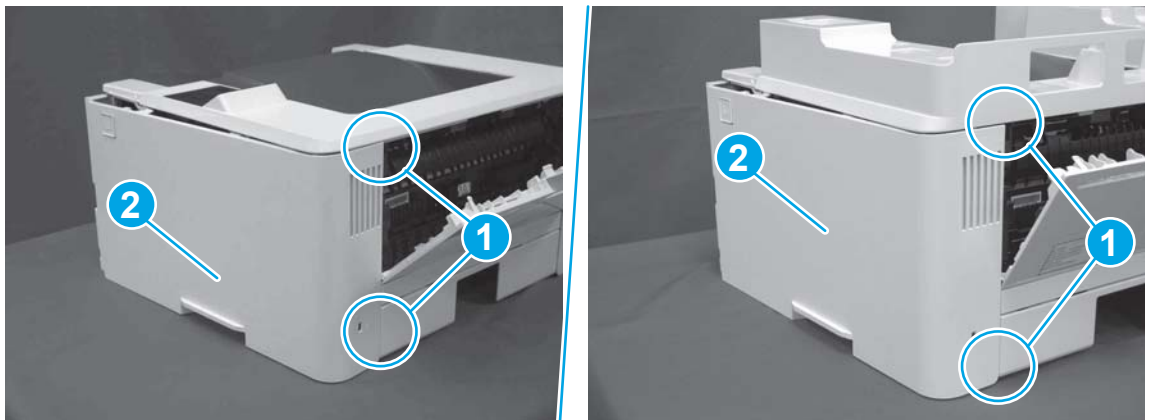

3. Open the rear door, release two bosses (callout 1), and then remove the cover (callout 2).

Figure 1-454 Remove the cover



Step 5: Remove the integrated scanner assembly (M427/M246)

 **NOTE:** The step is for the M427/M246 printer. For the M403/M402, skip this step and go to [Step 8: Remove the top cover \(M403/M402\)](#) on page 269.

 **NOTE:** M427/M426 models only. The integrated scanner assembly (ISA) includes the sub-scanner assembly (SSA) and the automatic document feeder (ADF).

1. Raise the ISA.

Figure 1-455 Raise the ISA

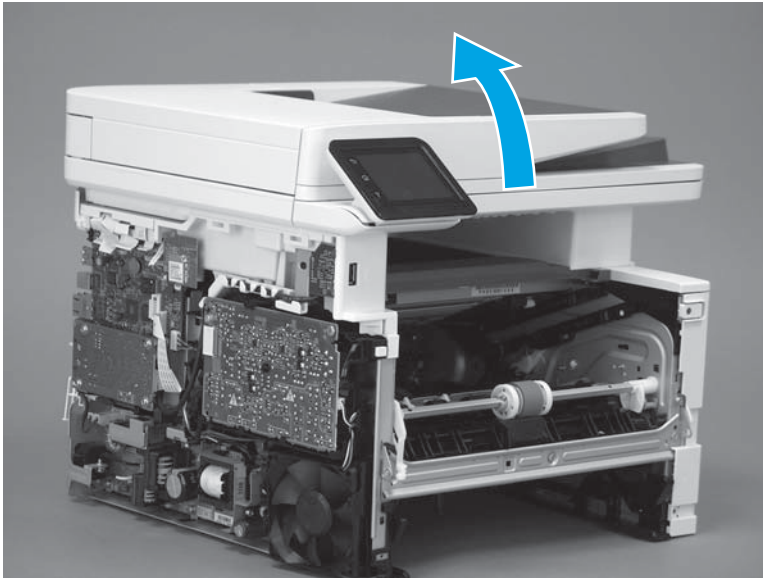

2. Release the ISA flat-flexible cable (FFC) cover (callout 1), and then remove it (callout 2).

Figure 1-456 Remove the ISA FFC cover

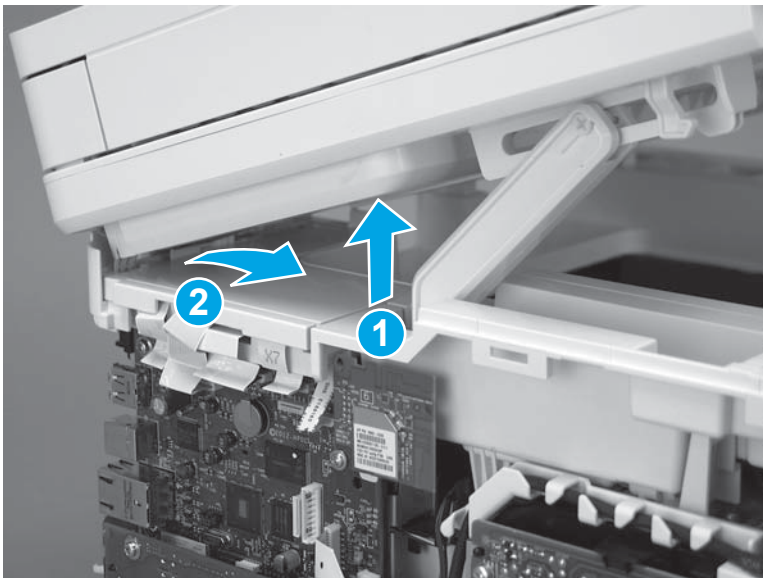

3. Disconnect three FFCs (callout 1), and then remove the ferrite (callout 2) from the holder.

CAUTION: The ferrite is not captive on the FFC. Do not lose the ferrite while handling the ISA.

Figure 1-457 Disconnect three FFCs

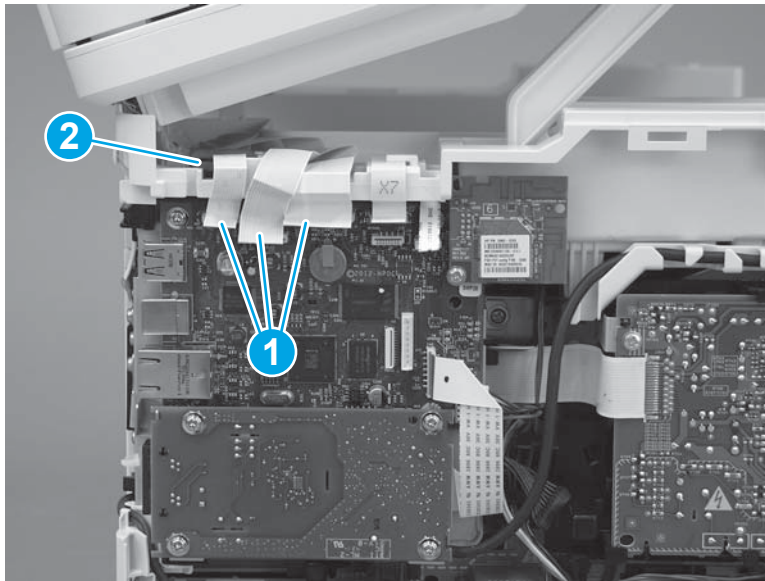

4. Remove one screw (callout 1).

Figure 1-458 Remove one screw

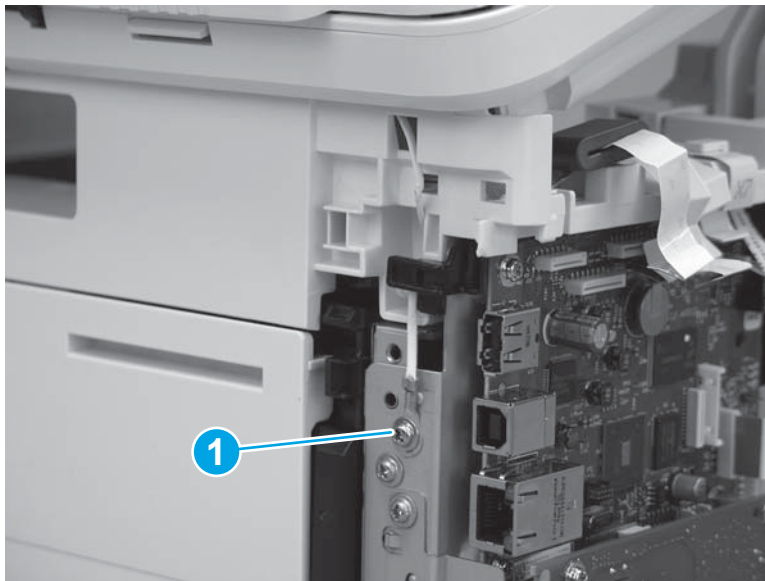

5. Pass the ground wire through the opening in the top cover.

Figure 1-459 Pass the wire through the opening

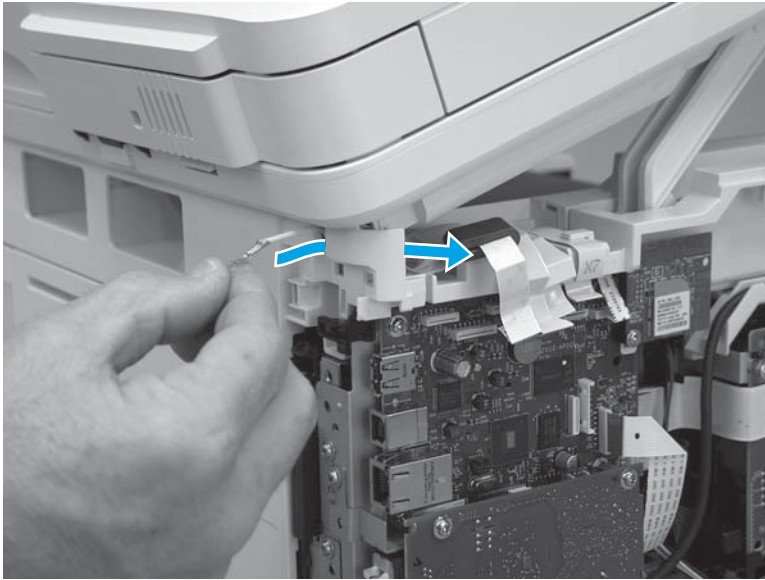

6. Release one tab (callout 1), and then rotate the ISA slider pin (callout 2) towards the front of the printer to release it.

Figure 1-460 Release one tab and rotate the slider pin

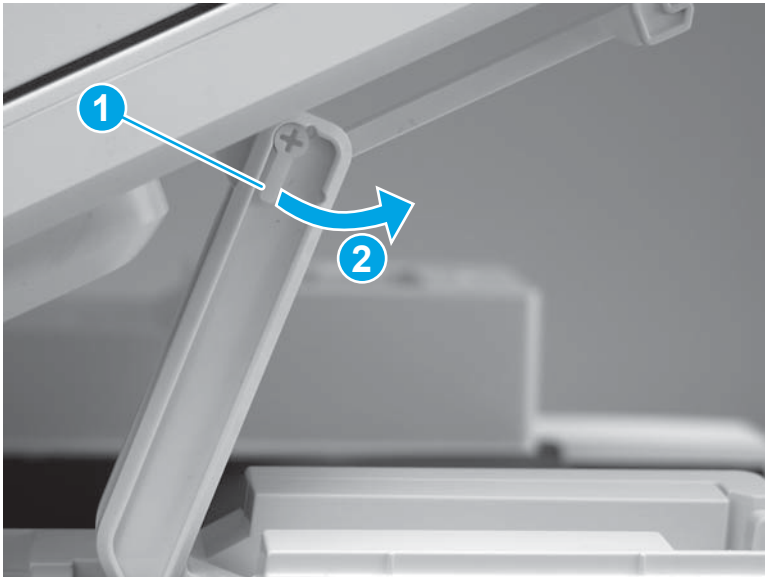

7. Remove the slider pin.

Figure 1-461 Remove the slider pin

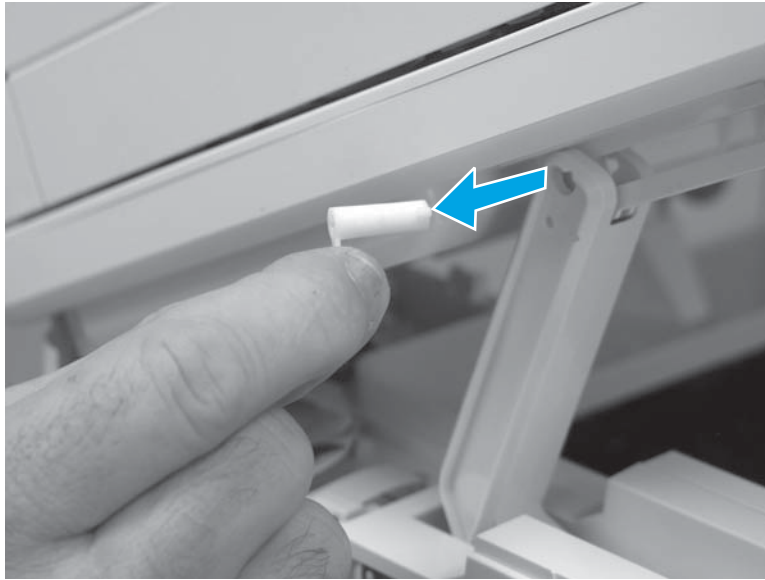

8. Rotate the ISA towards the rear of the printer until it stops.

Figure 1-462 Rotate the ISA towards the rear of the printer



- Slide the ISA as shown to release it.

Figure 1-463 Release the ISA

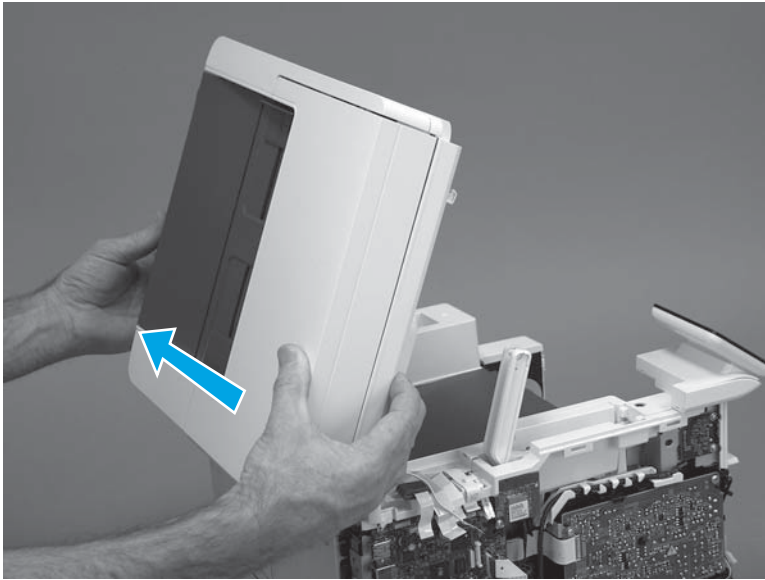

- Remove the ISA.

Figure 1-464 Remove the ISA

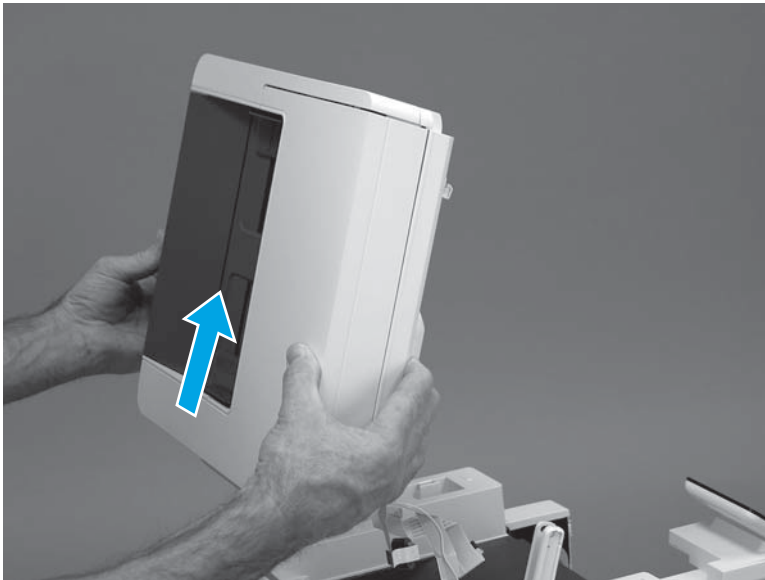

Step 6: Remove the control panel (M427/M246)



NOTE: The step is for the M427/M426 printer. For the M403/M402, skip this step and go to [Step 8: Remove the top cover \(M403/M402\)](#) on page 269.

- Disconnect one FFC (callout 1; J114), and then release the FFC from the retainer (callout 2).

Figure 1-465 Disconnect one connector

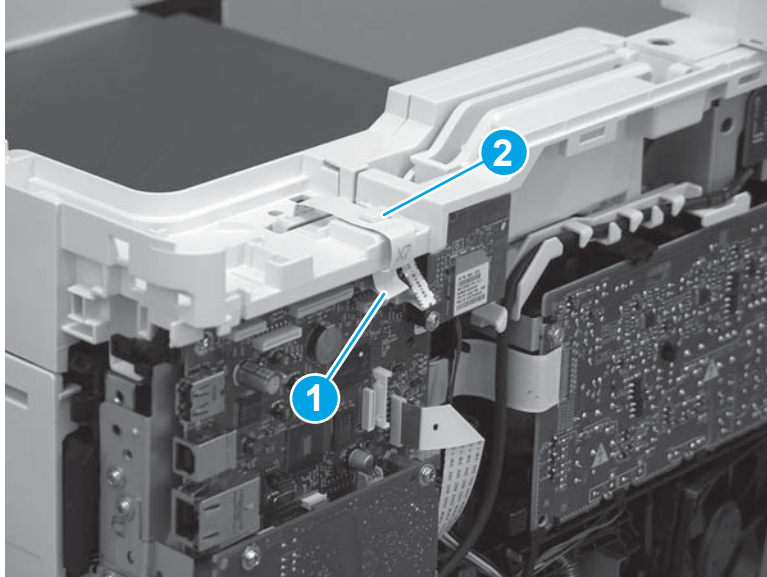

2. Remove one screw (callout 1).

Figure 1-466 Remove one screw

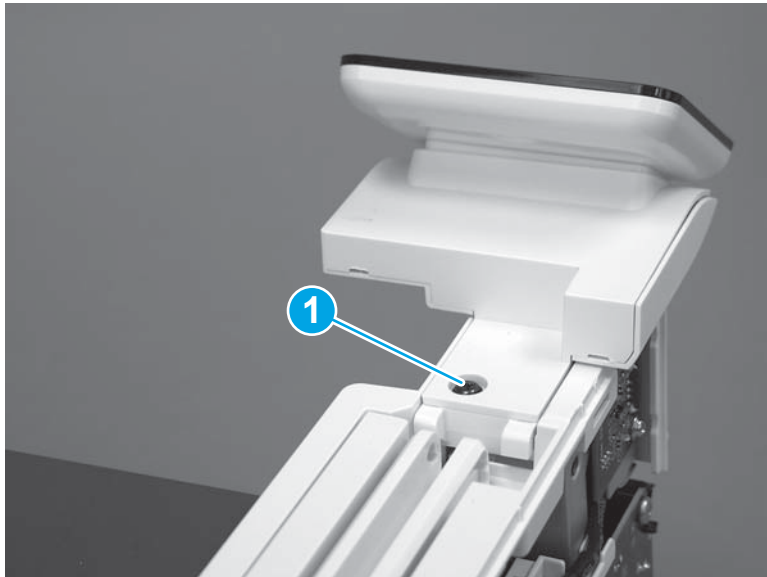

3. Use a small flat-blade screwdriver to release two tabs (callout 1) on the control-panel cable cover.

Figure 1-467 Release two tabs

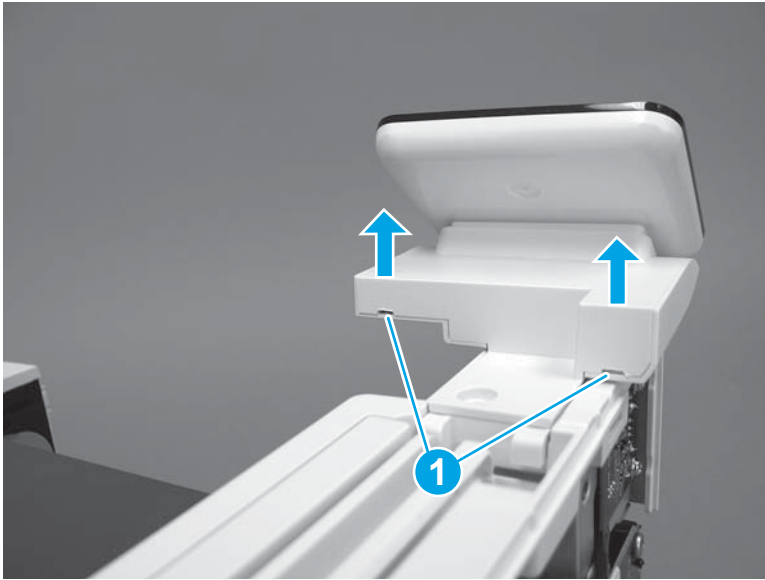

4. Remove the control-panel cable cover.

Figure 1-468 Remove the cover

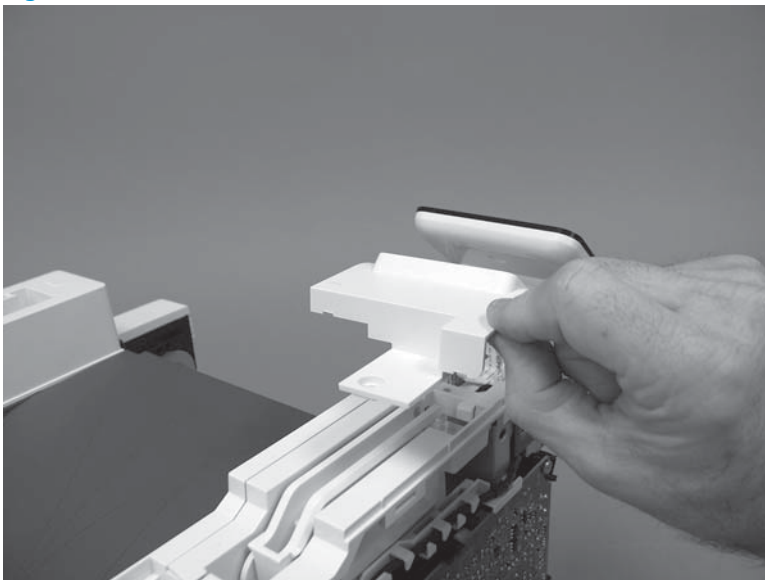

5. Remove one grounding screw (callout 1), and then move the ground cable (callout 2) out of the way.

Figure 1-469 Remove one screw

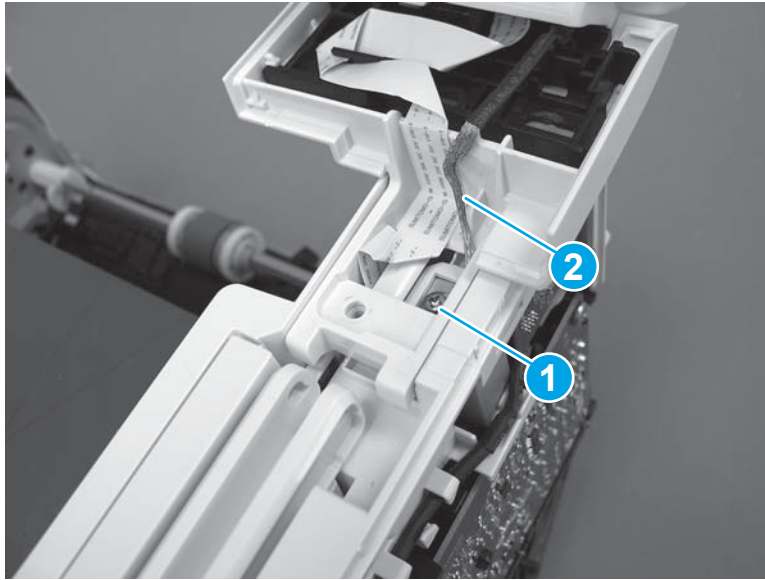

6. Move the FFC out of the way, and then remove two screws (callout 1).

Figure 1-470 Remove two screws

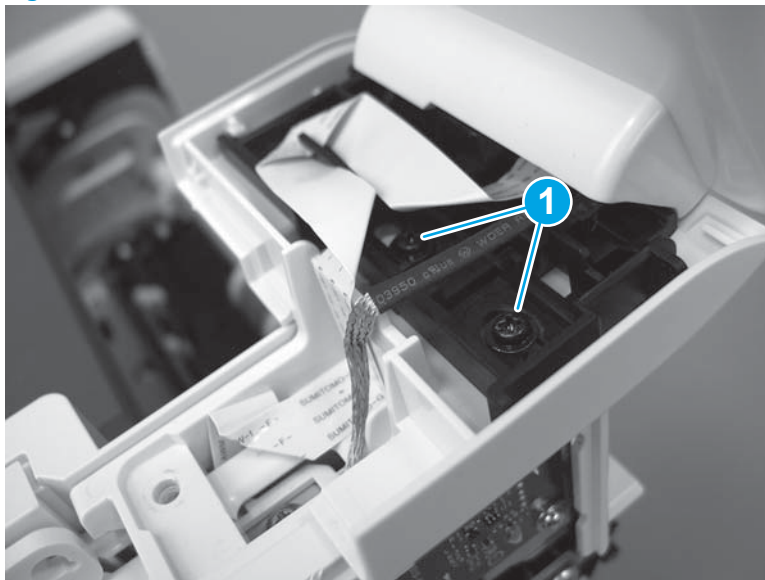

7. Slightly lift up the control-panel assembly to separate it from the top cover.

⚠ CAUTION: The control panel assembly is still connected to the printer by the FFC. Do not attempt to completely remove the assembly.

Figure 1-471 Lift up the control-panel assembly

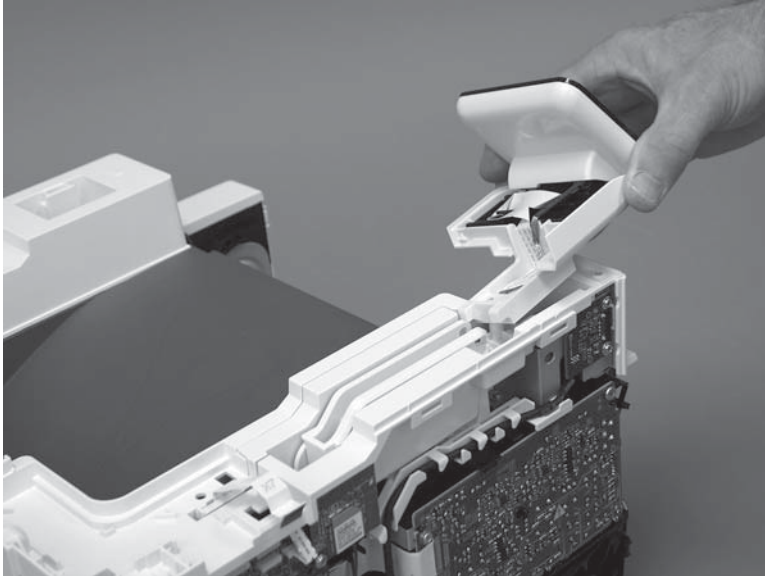

8. Lift up the control-panel FFC cover to remove the control-panel assembly.

Figure 1-472 Remove the control-panel assembly

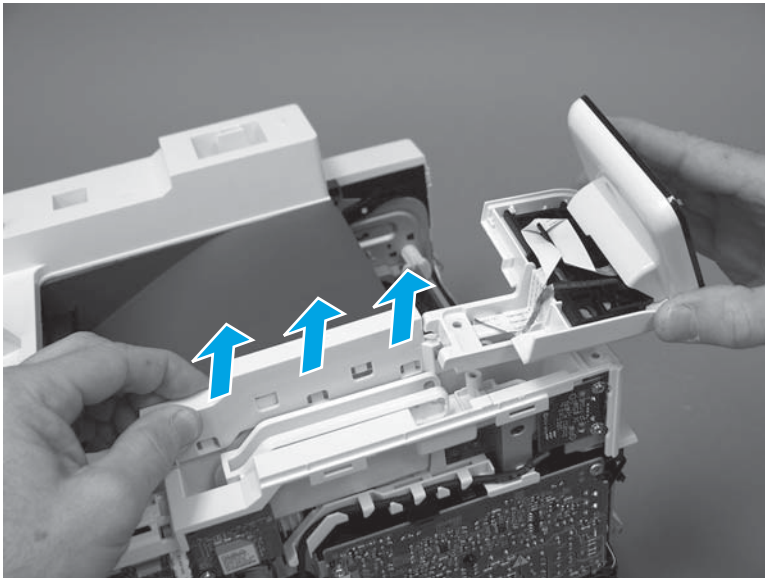

Step 7: Remove the top cover (M427/M426)

📝 NOTE: The step is for the M427/M426 printer. For the M403/M402, skip this step and go to [Step 8: Remove the top cover \(M403/M402\) on page 269](#).

1. Release the USB cable (callout 1) from the cable guide.

Figure 1-473 Remove the USB cable

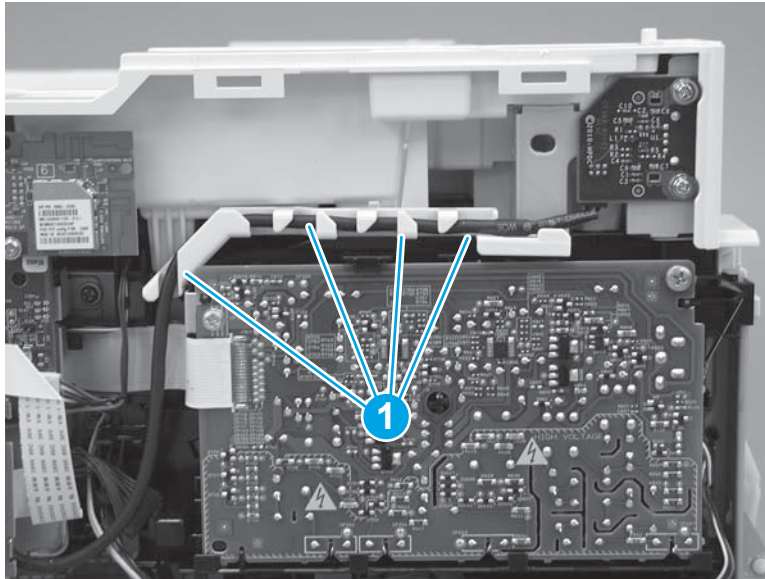

2. Remove five screws (callout 1), release four bosses (callout 2), and then remove the top cover (callout 3).

Figure 1-474 Remove the cover

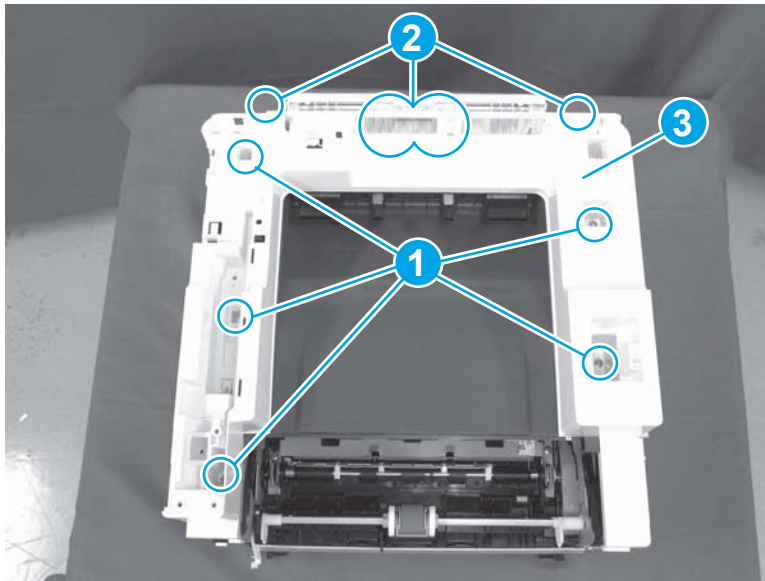

Step 8: Remove the top cover (M403/M402)

 **NOTE:** The step is for the M403/M402 printer. For the M427/M426, skip this step and go to [Step 9: Remove the paper delivery tray \(output bin\) on page 271.](#)

1. Remove one screw (callout 1).

Figure 1-475 Remove one screw



2. At the right side of the printer, release the one boss (callout 1), and then release one tab (callout 2).

Figure 1-476 Release one boss and one tab

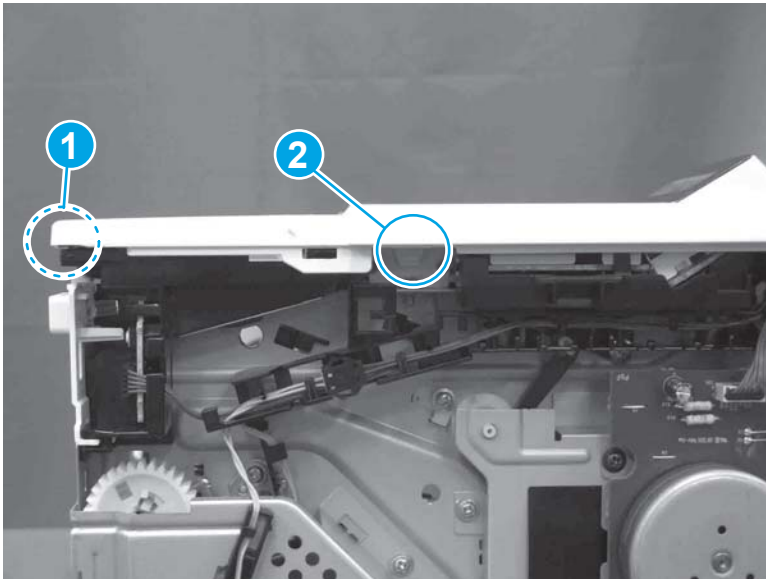

3. Release four tabs (callout 1), release four bosses (callout 2), and then remove the top cover (callout 3).



 **TIP:** Open the rear door to make releasing the bosses (callout 3) easier.

Figure 1-477 Remove the cover

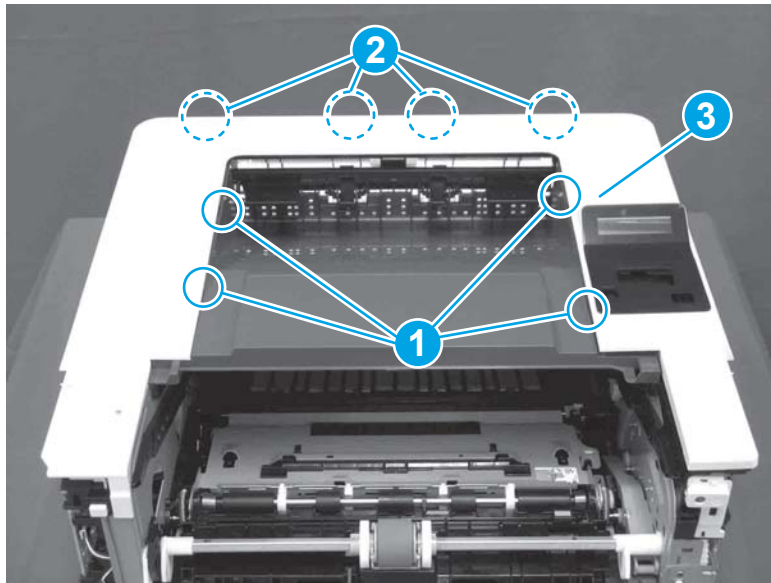

Step 9: Remove the paper delivery tray (output bin)

 **NOTE:** This procedure shows the M403/M402 model, however, the paper delivery tray (output bin) removal is similar for the M427/M426 printer.

- ▲ Release two bosses (callout 1), release two tabs (callout 2), and then remove the paper delivery tray (output bin; callout 3).

Figure 1-478 Release two tabs

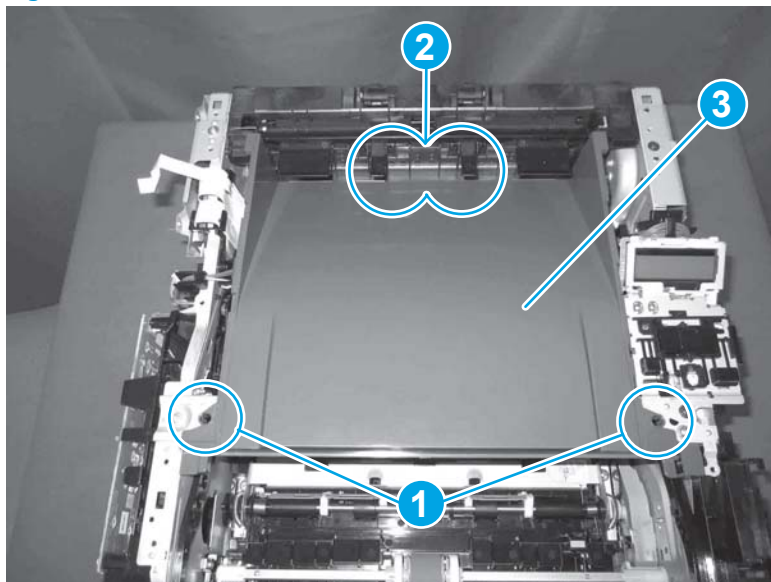

Step 10: Unpack the replacement assembly

Unpack the replacement part from the packaging.

<http://www8.hp.com/us/en/hp-information/environment/product-recycling.html>

 **NOTE:** HP recommends responsible disposal of the defective part.

Figure 1-479 Recycle and unpack

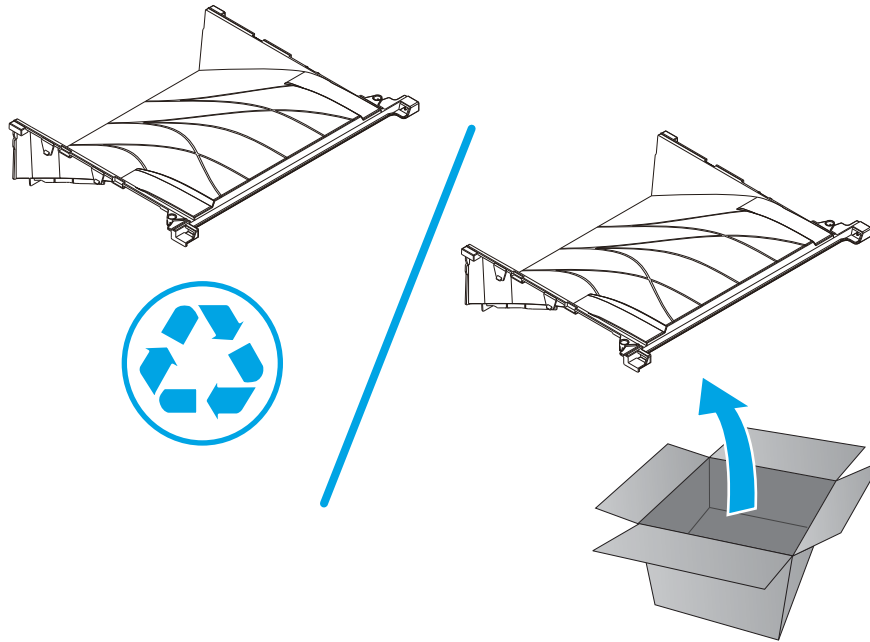

Step 11: Install the paper delivery tray (output bin)

 **NOTE:** This procedure shows the M403/M402 model, however, the paper delivery tray (output bin) removal is similar for the M427/M426 printer.

- ▲ Position the remove the paper delivery tray (output bin; callout 1) on the printer, engage two tabs (callout 2), and then engage two bosses (callout 3).

Figure 1-480 Engage two tabs

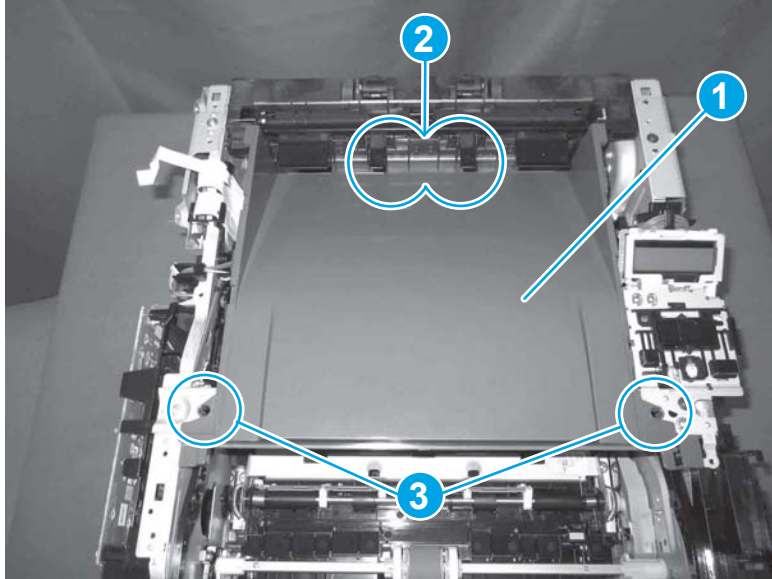

Step 12: Install the top cover (M403/M402)

 **NOTE:** The step is for the M403/M402 printer. For the M427/M426, skip this step and go to [Step 13: Install the top cover \(M427/M426\) on page 275](#).

1. Position the rear edge of the cover on the printer.

Figure 1-481 Install the cover

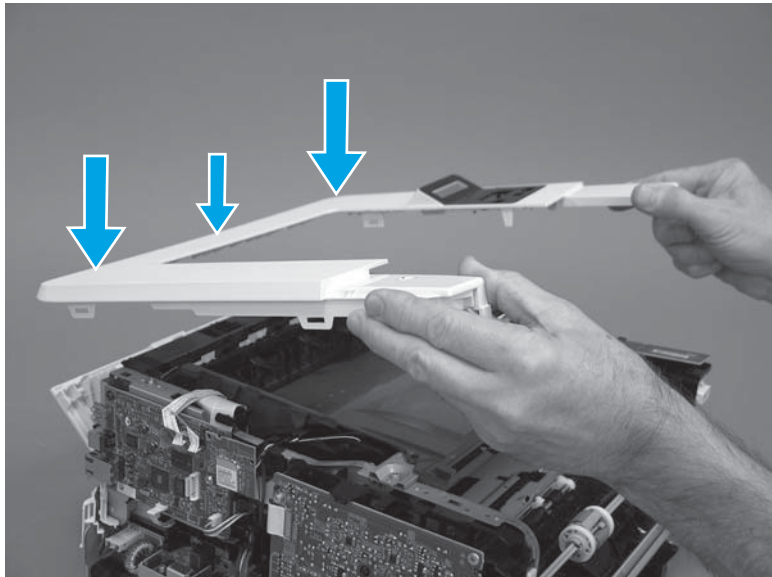

2. Engage four bosses (callout 1), rotate the front of the cover down (callout 2) and onto from the printer, and then engage four tabs (callout 3).

Figure 1-482 Engage four bosses and tabs

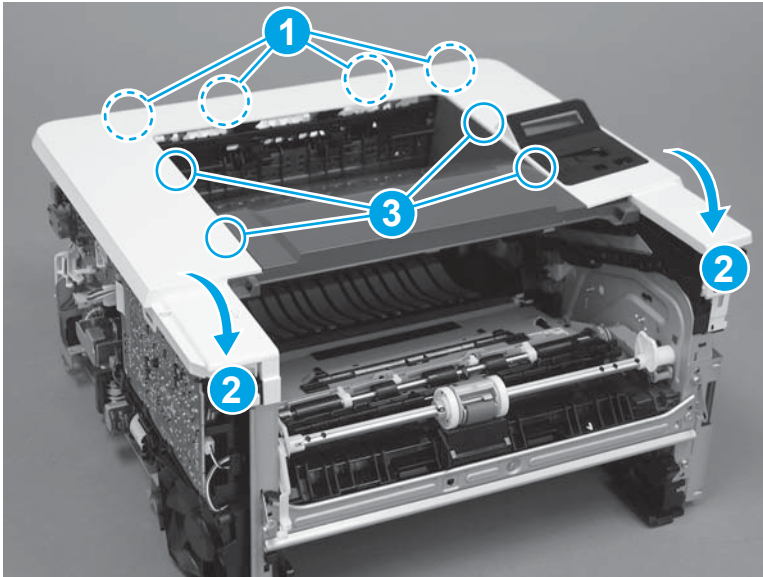

3. At the right side of the printer, engage the one boss and one tab (callout 1).

Figure 1-483 Engage one boss and one tab

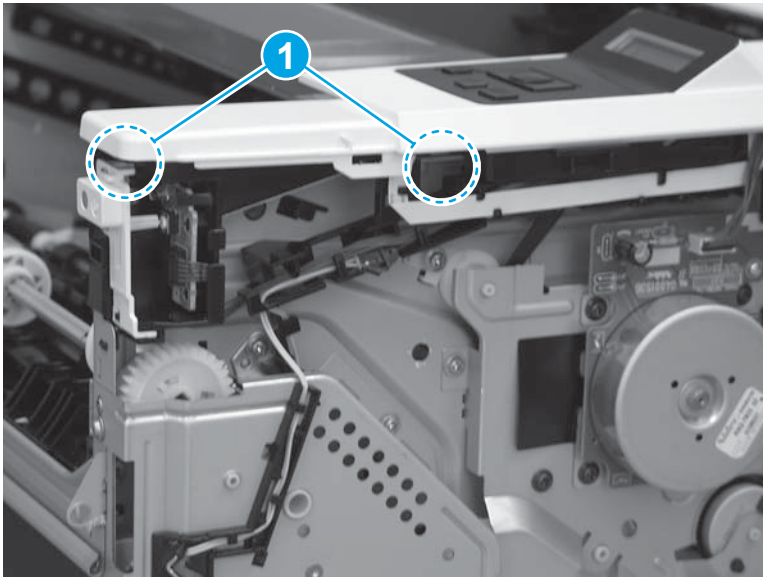

4. Install one screw (callout 1).

Figure 1-484 Install one screw

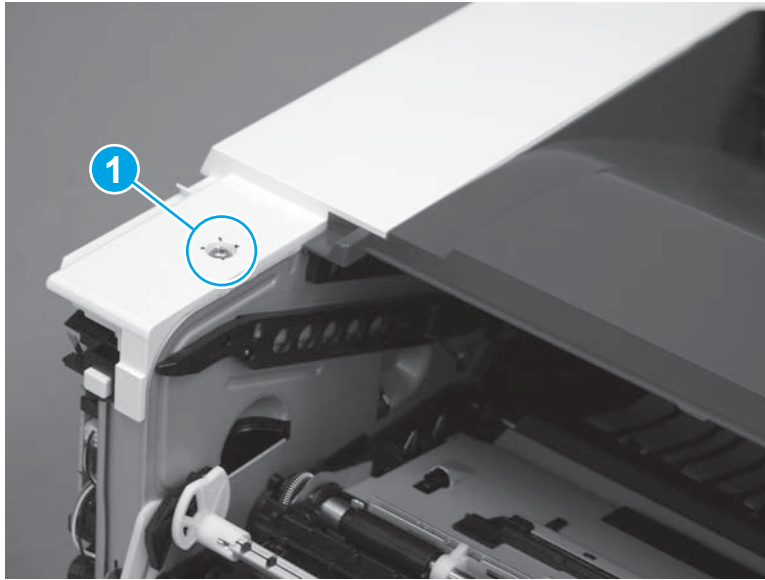

Step 13: Install the top cover (M427/M426)

 **NOTE:** The step is for the M427/M426 printer. For the M403/M402, skip this step and go to [Step 16: Install the right cover on page 286](#).

1. Position the rear edge of the top cover on the printer.

Figure 1-485 Install the cover

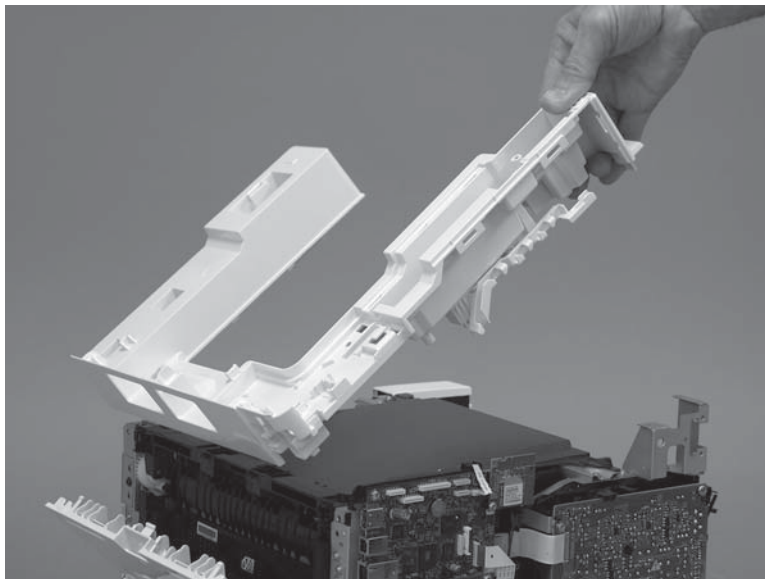

2. Engage four bosses (callout 1).

Figure 1-486 Engage four bosses

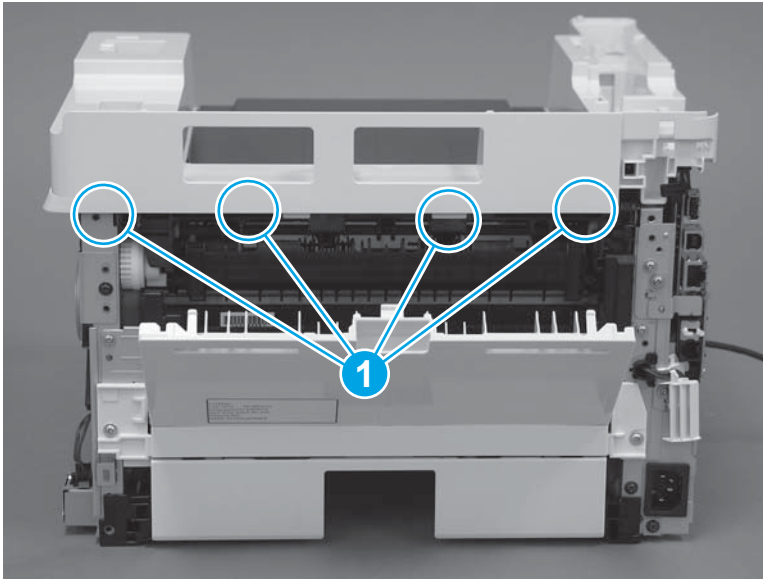

3. Rotate the front edge of the cover down.

Figure 1-487 Rotate the front edge of the cover down

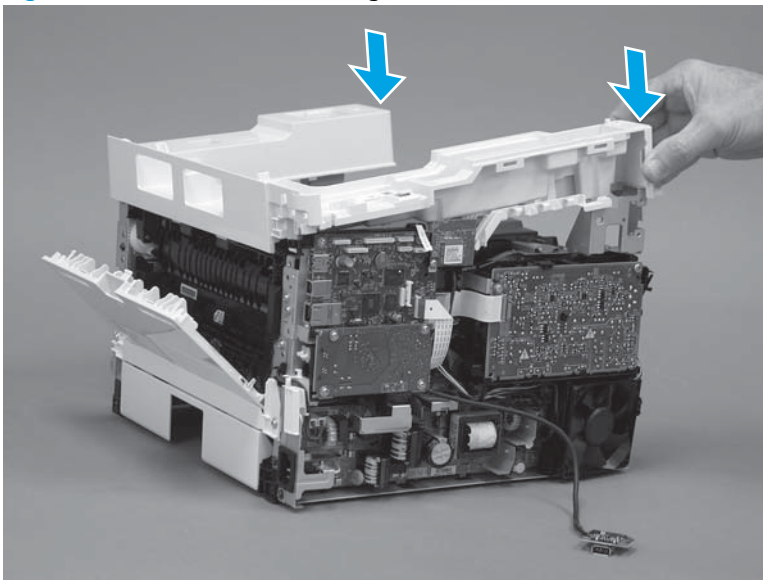

4. Install the USB cable (callout 1) in the guide.

Figure 1-488 Install the USB PCA

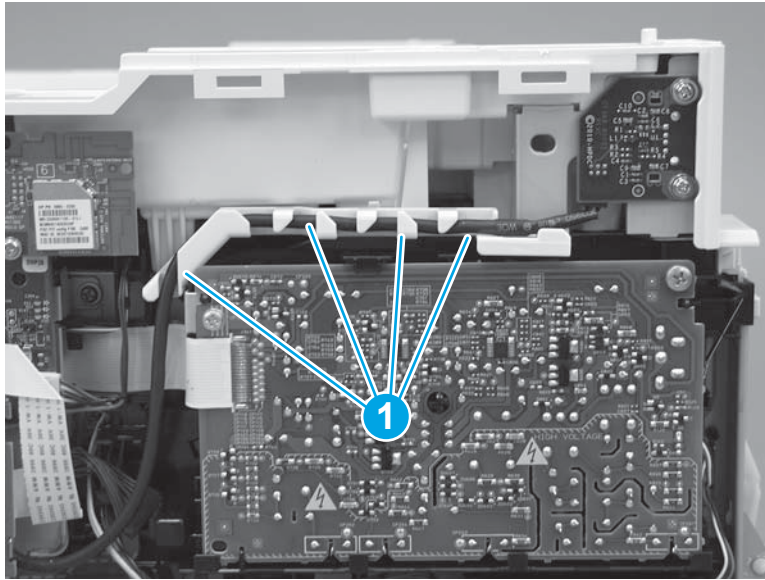

5. Install five screws (callout 1).

Figure 1-489 Install five screws

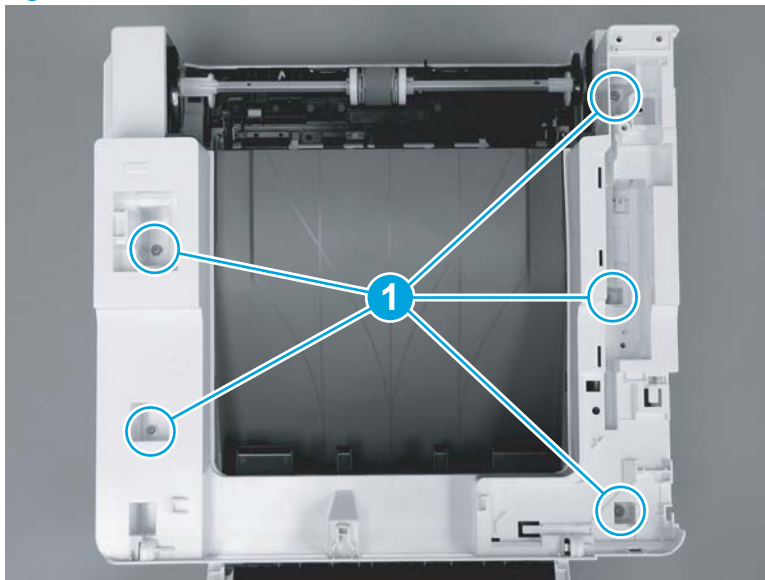

Step 14: Install the control panel (M427/M246)

 **NOTE:** The step is for the M427/M426 printer. For the M403/M402, skip this step and go to [Step 16: Install the right cover on page 286](#).

1. Slide the control-panel FFC cover into the slot in the top cover (next to the document feeder support arm) to install it.

Figure 1-490 Install the control-panel FFC cover

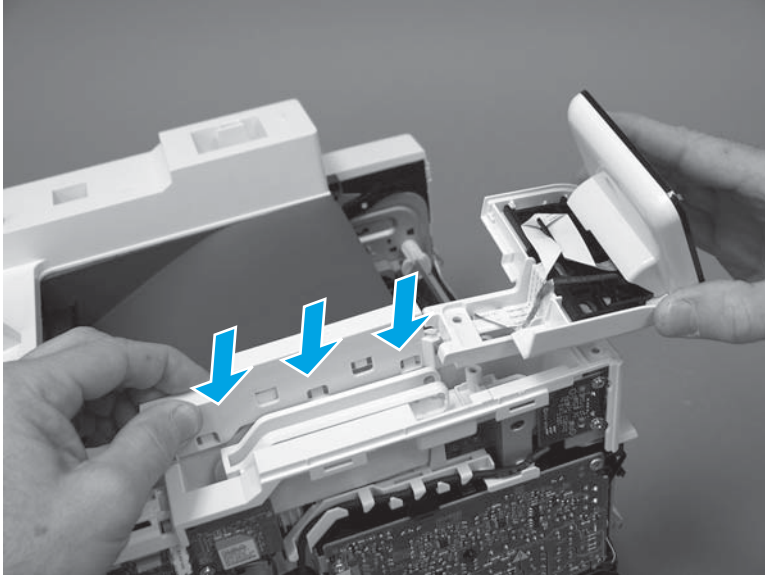

2. Install the control-panel assembly on the top cover.

Figure 1-491 Install the control-panel assembly

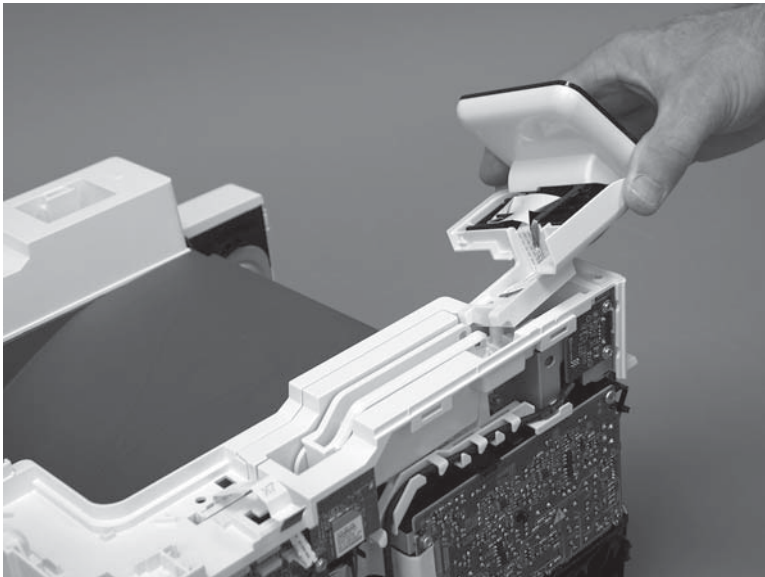

3. Move the FFC out of the way, and then install two screws (callout 1).

Figure 1-492 Install two screws

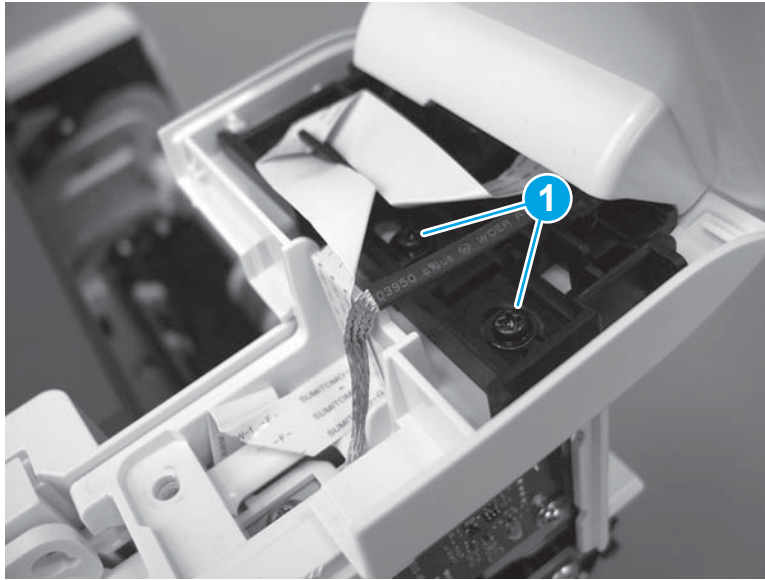

4. Install one grounding screw (callout 1), and then make sure that the ground cable (callout 2) is properly routed.

Figure 1-493 Remove one screw

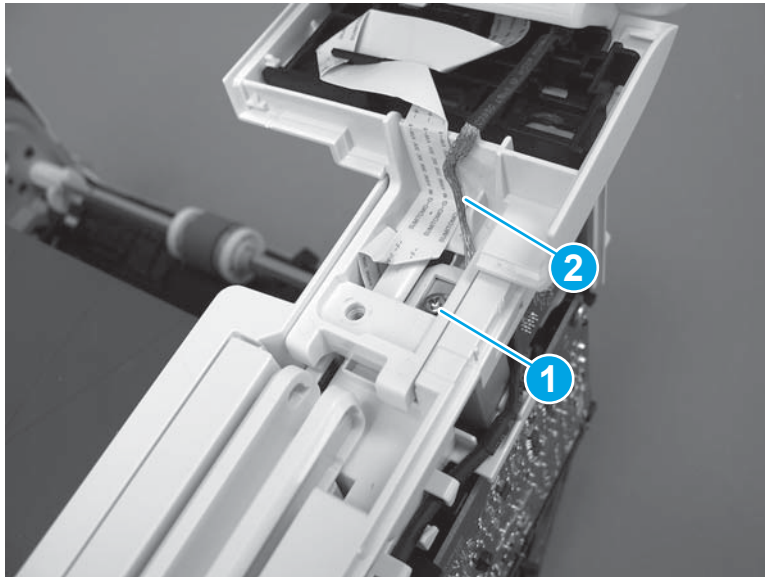

5. Install the control-panel cable cover.

Figure 1-494 Install the cover

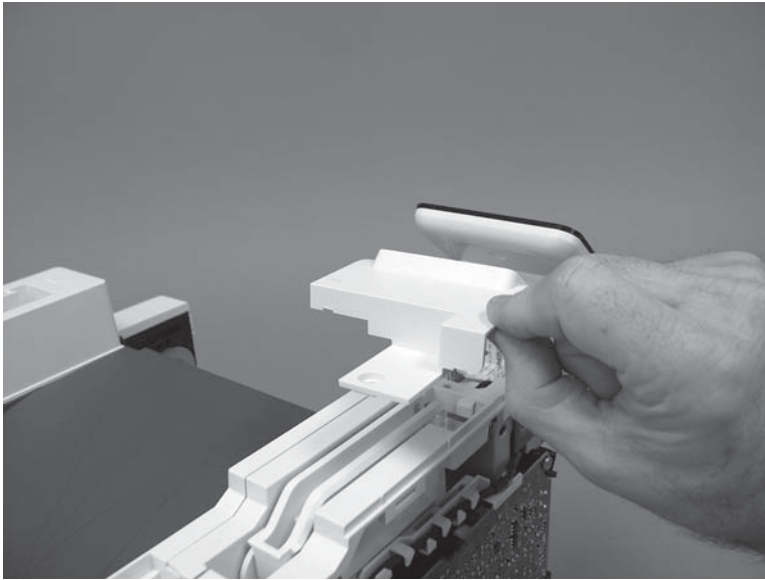

6. Make sure that the two tabs (callout 1) on the cover snap into place.

Figure 1-495 Engage two tabs

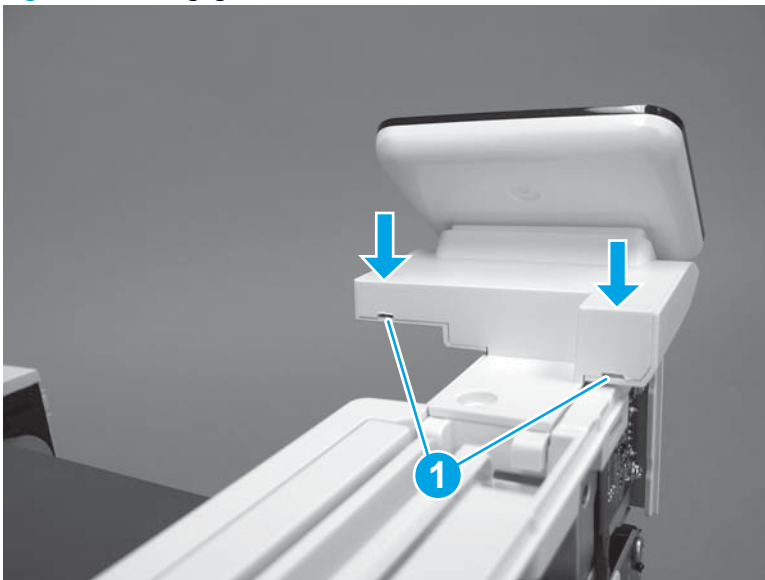

7. Install one screw (callout 1).

Figure 1-496 Install one screw

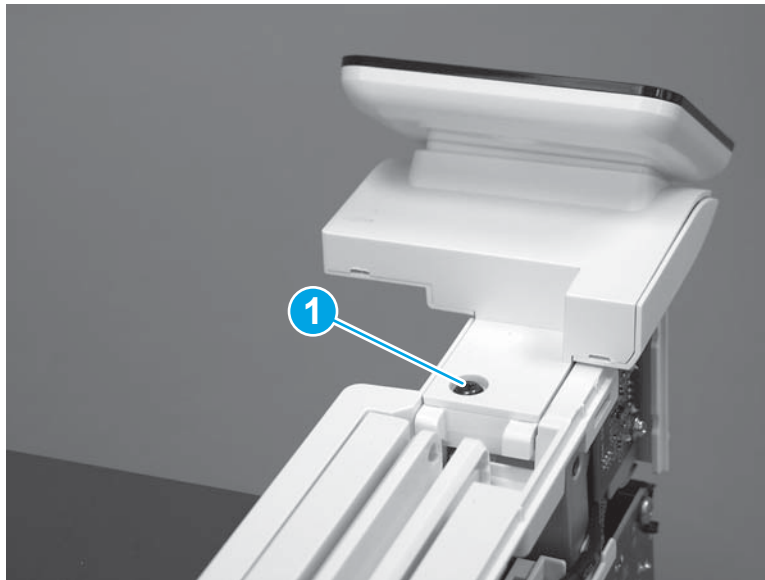

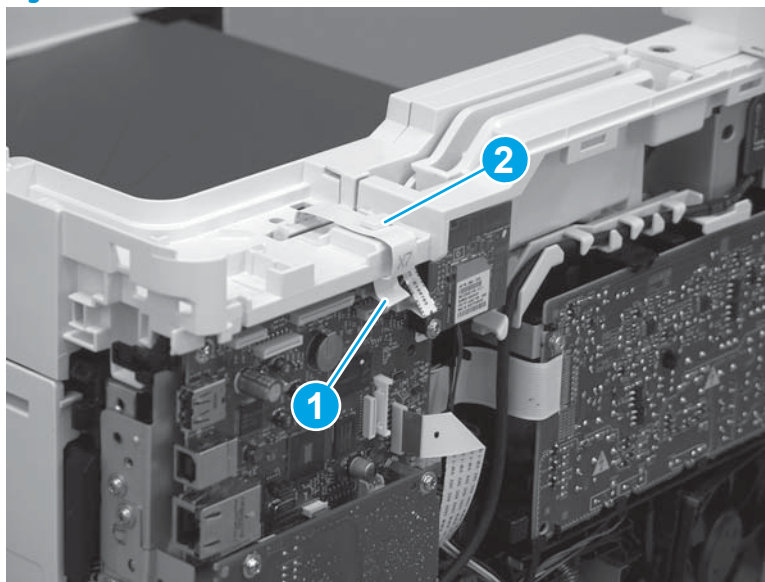

8. Install the FFC in the retainer (callout 1), and then connect one FFC (callout 1; J114).

Figure 1-497 Connect one connector



Step 15: Install the integrated scanner assembly (M427/M246)

 **NOTE:** The step is for the M427/M426 printer. For the M403/M402, skip this step and go to [Step 16: Install the right cover on page 286](#).

 **NOTE:** M427/M426 models only. The integrated scanner assembly (ISA) includes the sub-scanner assembly (SSA) and the automatic document feeder (ADF).

1. Position the ISA on the printer.

Figure 1-498 Position the ISA on the printer

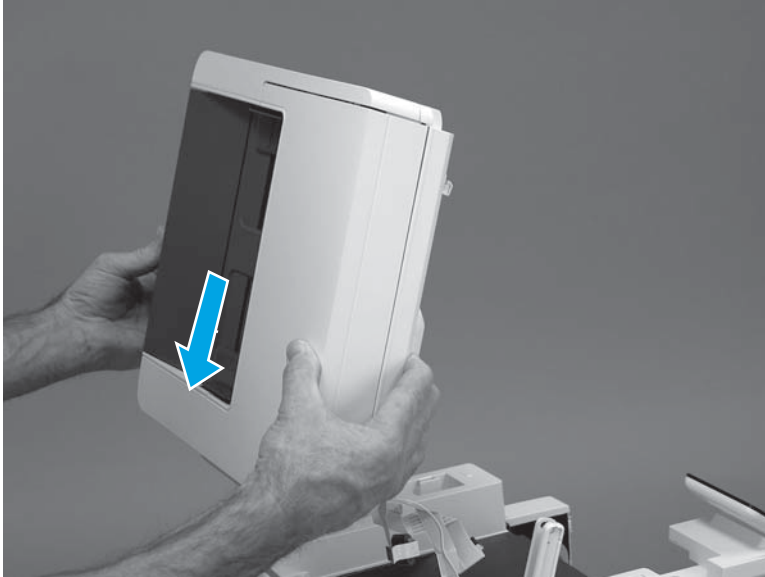

2. Engage the hinge pins on the ISA with the holders in the top cover (callouts 1/2), and then slide the ISA as shown to engage them

Figure 1-499 Engage the hinge pins with the holders

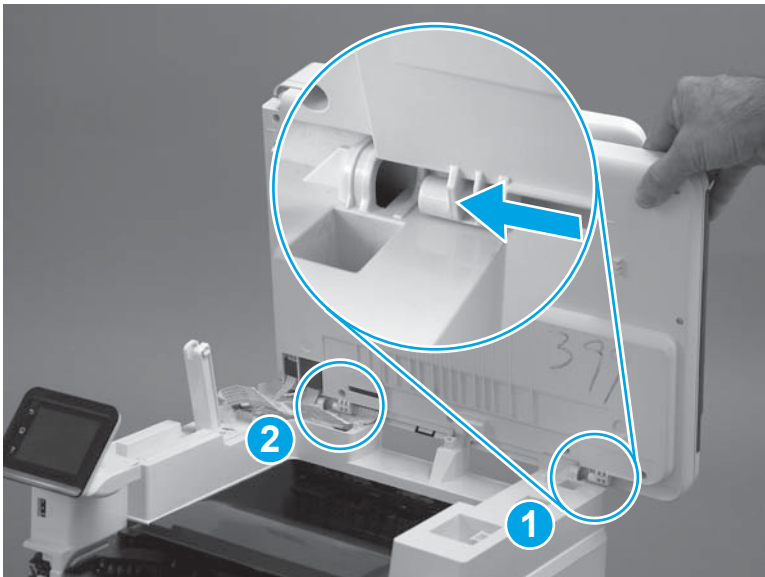

3. Rotate the ISA towards the front of the printer until it rests on the ISA lift assembly (callout 1).

Figure 1-500 Rotate the ISA towards the front of the printer

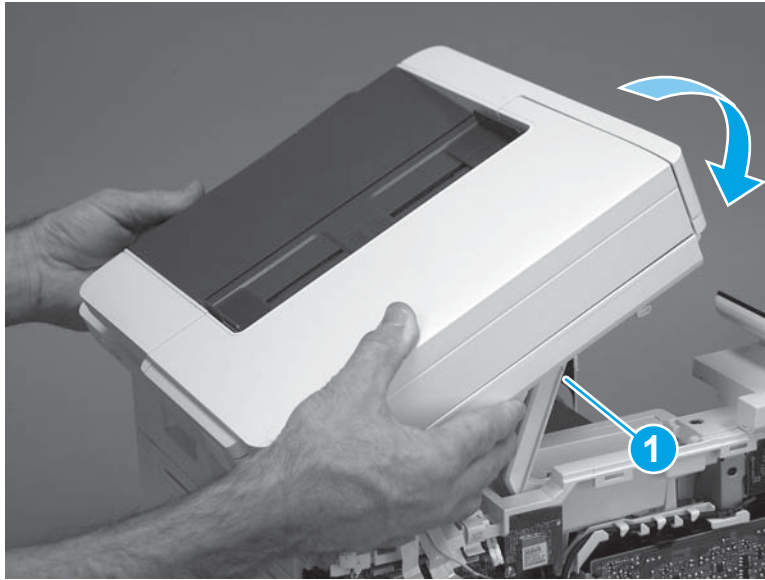

4. Pass the ground wire through the opening in the top cover.

Figure 1-501 Pass the wire through the opening

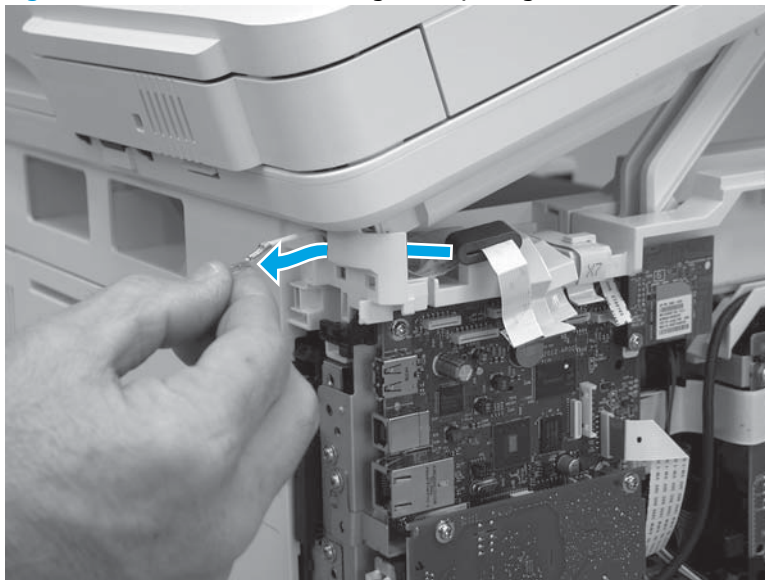

5. Install one screw (callout 1).

Figure 1-502 Install one screw

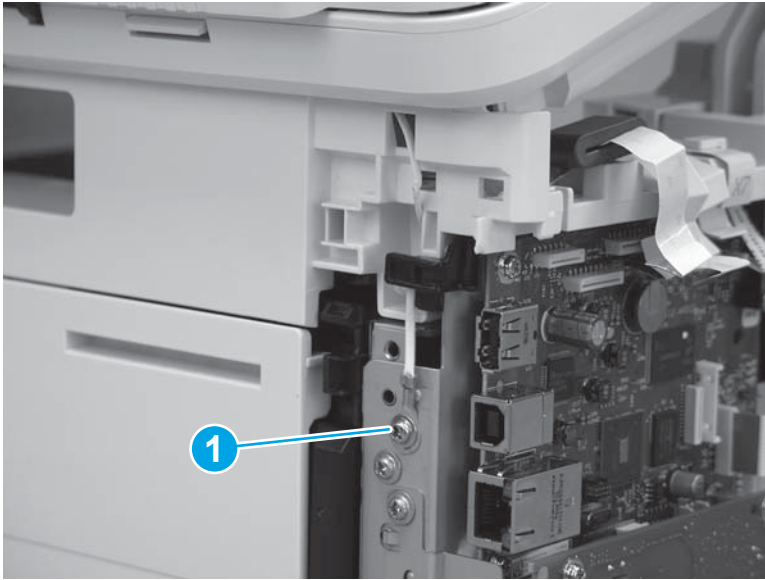

6. Install the ISA lift assembly slider pin.

 **Reinstallation tip:** Align the keyed portion of the locking pin with the slot and hole in the support arm.

Figure 1-503 Install the slider pin



7. Rotate the slider pin (callout 1) towards the rear of the printer until the tab (callout 2) snap into place.

Figure 1-504 Secure the slider pin

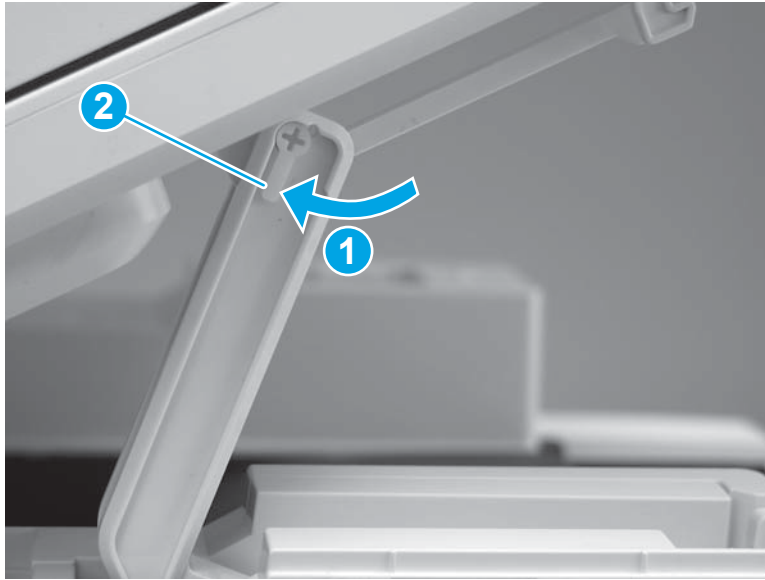

8. Install the ferrite (callout 1) in the holder, and then connect three FFCs (callout 2).

Figure 1-505 Connect three FFCs

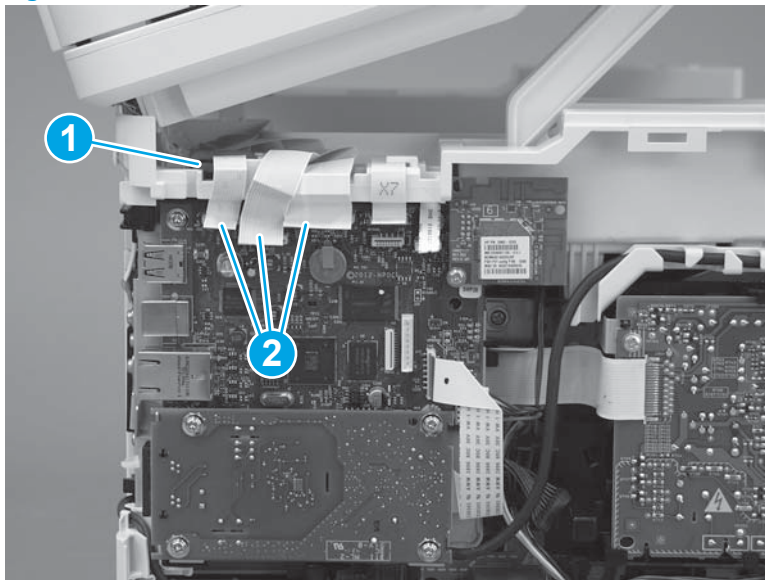

9. Position the rear edge of the ISA flat-flexible cable (FFC) cover on the printer (callout 1) , and then rotate it down (callout 2) until it snaps into place.

Figure 1-506 Install the ISA FFC cover

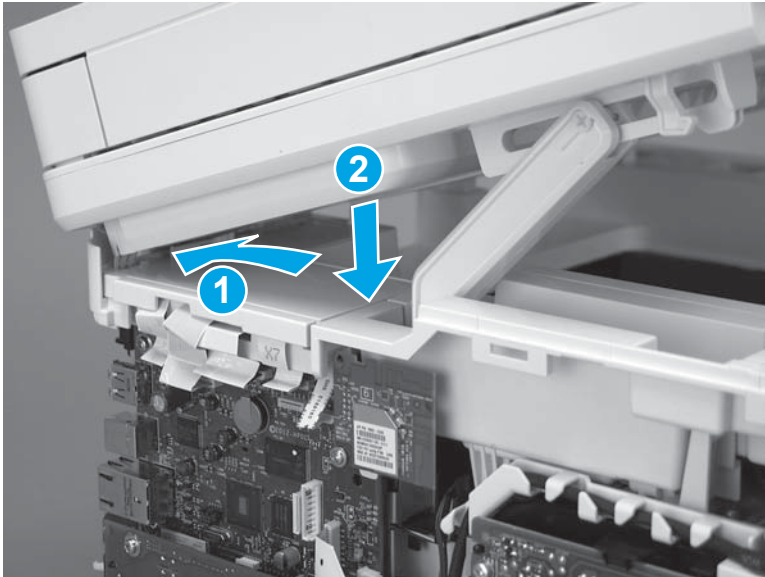

10. Lower the ISA.

Figure 1-507 Lower the ISA

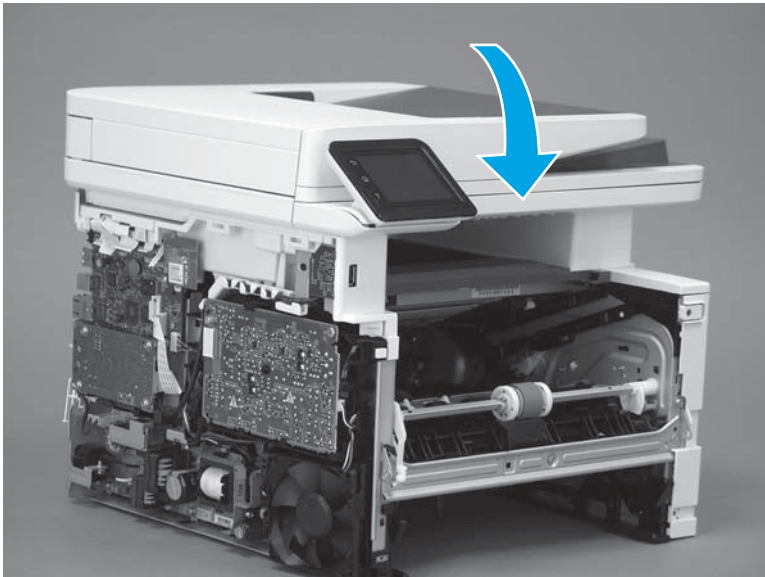

Step 16: Install the right cover

1. Position the cover (callout 1) on the printer, and then engage two bosses (callout 2).

Figure 1-508 Install the cover

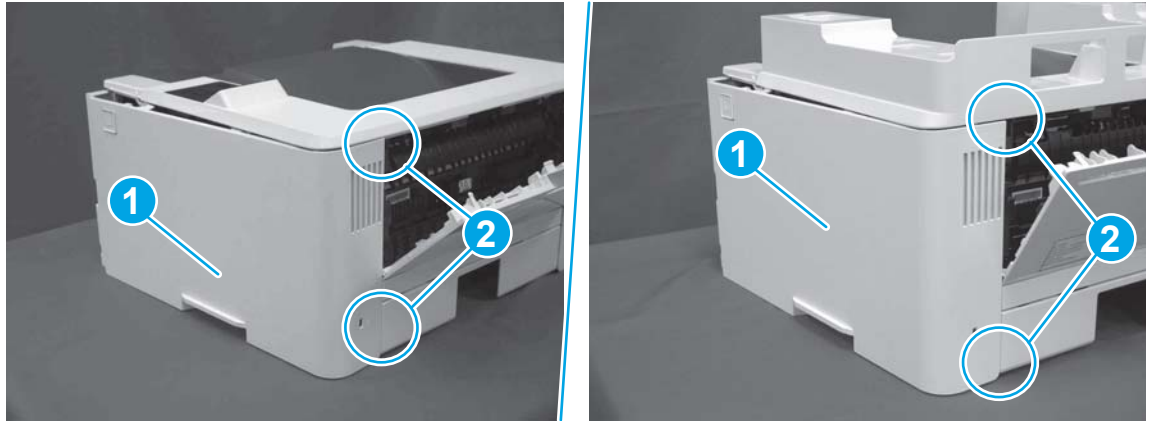

2. Rotate the front of the cover onto the printer (callout 1), engage three (callout 2) tabs, and then engage two bosses (callout 3).

Figure 1-509 Engage two bosses and one tab

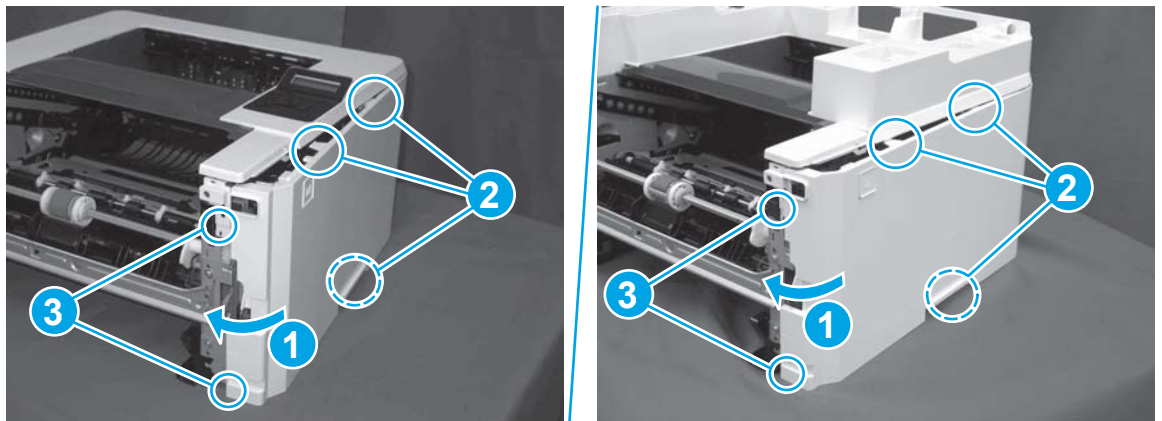

3. Make sure that the power switch (callout 1) and cartridge door assembly button (callout 2) correctly function.

 **NOTE:** Remove, and then reinstall the cover if the switch or button does not correctly function.

Figure 1-510 Check the power switch and cartridge door assembly button

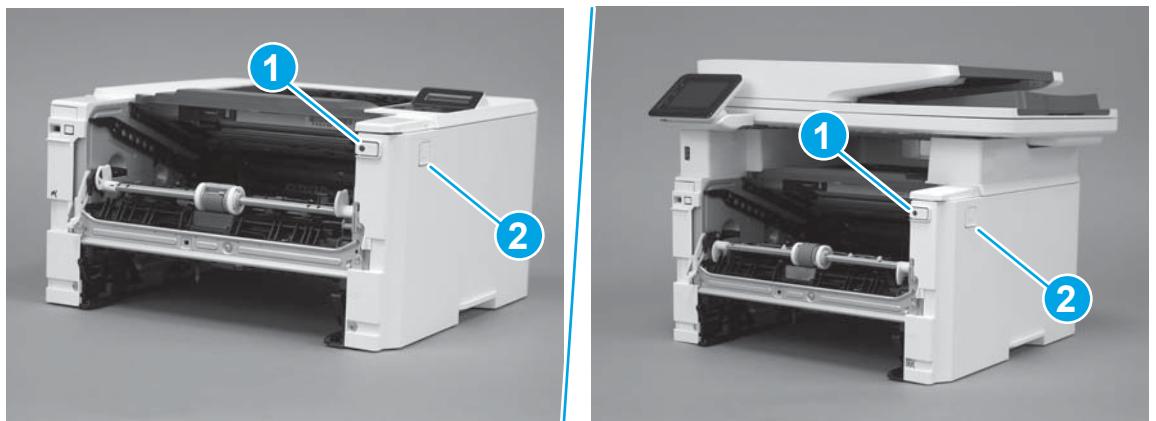

4. Install one screw (callout 1).

Figure 1-511 Install one screw



Step 17: Install the left cover

1. At the front of the printer, do one of the following:
 - **M403/M402:** Position the cover on the printer (callout 1), and then engage two bosses (callout 2).
 - **M427/M426:** Position the cover on the printer (callout 3), engage one tab (callout 4), and then engage two bosses (callout 4).

Figure 1-512 Install the cover

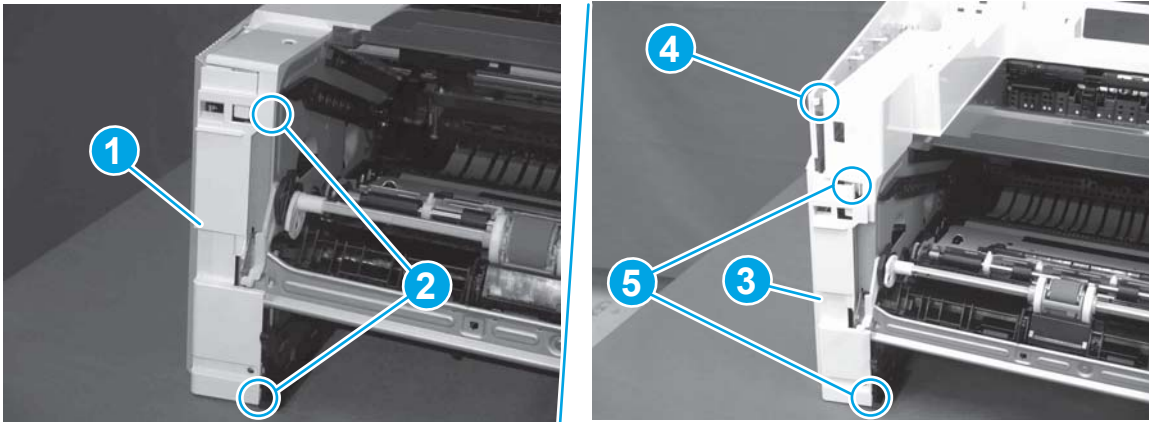

- Carefully rotate the rear of the cover onto the printer (callout 1), engage three tabs (callout 2), and then engage two bosses (callout 3).

Figure 1-513 Engage three tabs and two bosses

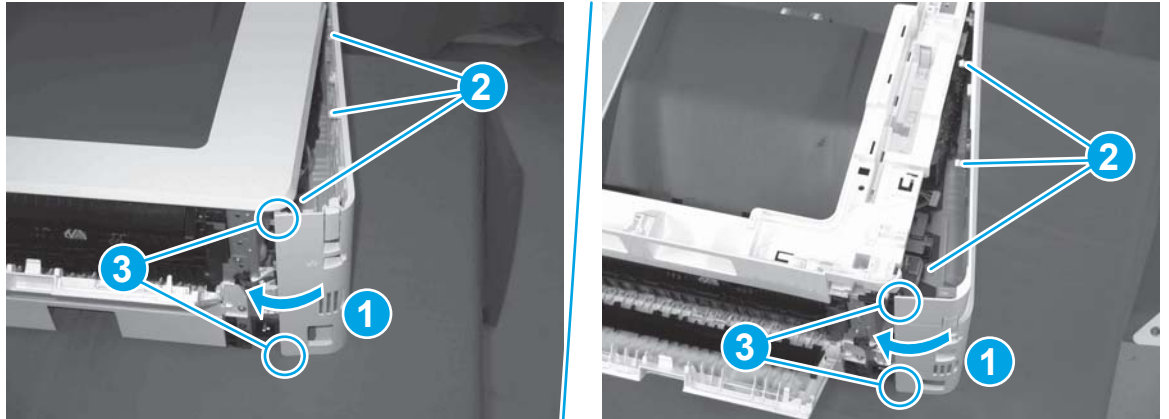

- Install one screw (callout 1).

Figure 1-514 Install one screw

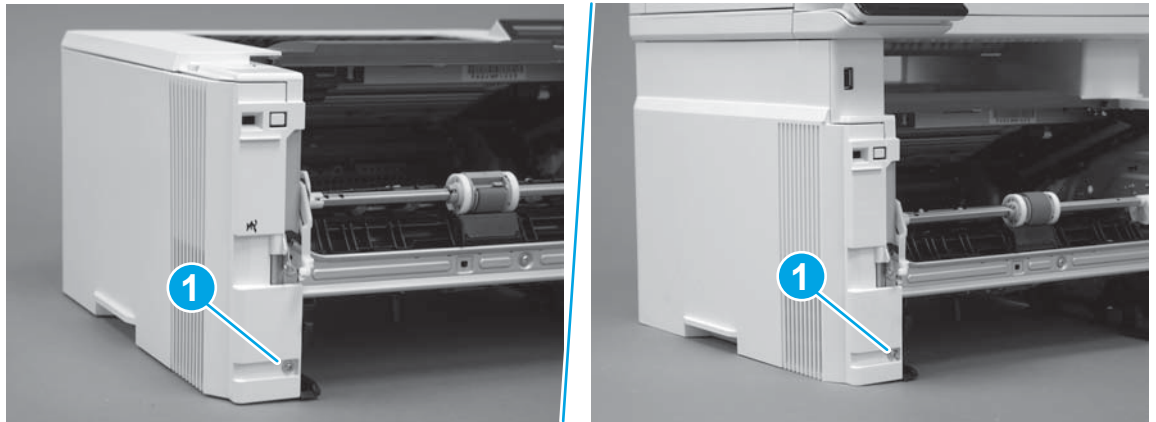

Step 18: Install the cartridge door assembly

 **Reinstallation tip:** After a replacement door is installed, make sure to install the nameplate (supplied in the kit) corresponding to the printer name on the door.

- Position the door close to the printer, and then engage the keyed pin on the left-side retainer arm with the hole in the door.

Figure 1-515 Engage the left-side retainer arm

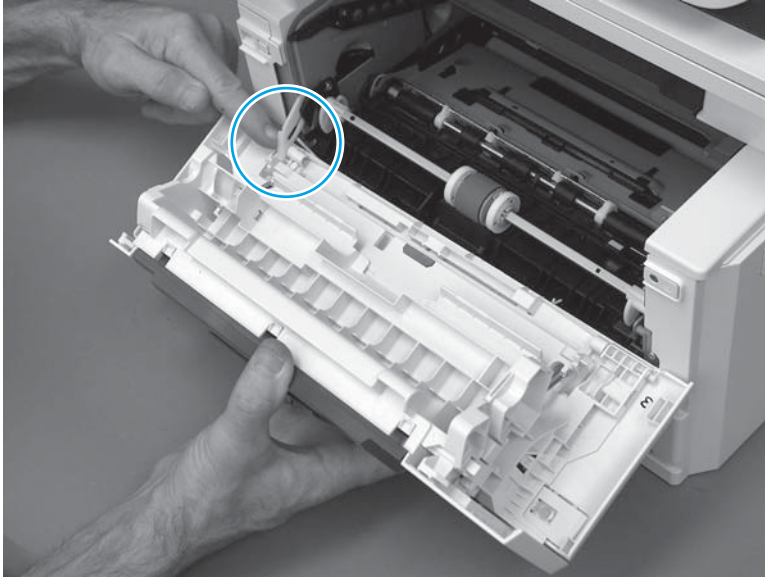

2. Engage the right-side door hinge pin with the hole in the chassis (callout 1).

Figure 1-516 Install the door

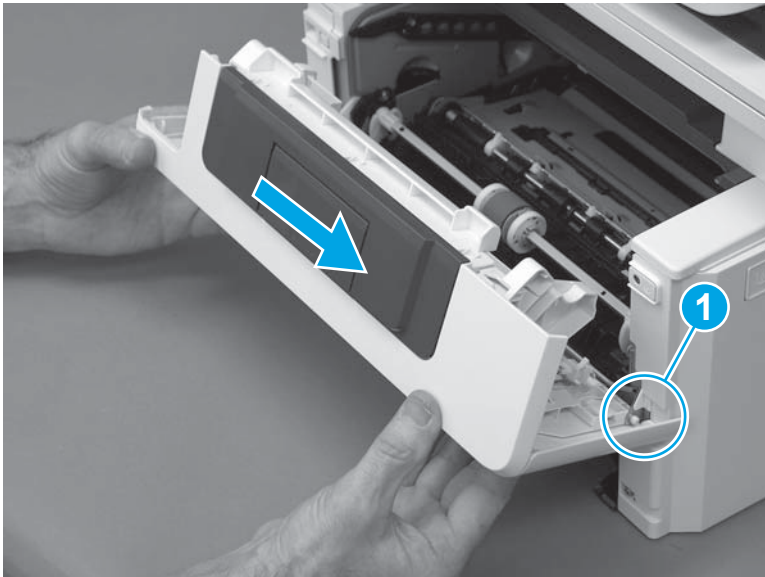

3. Install the link (callout 1).

 **IMPORTANT:** Make sure that the link snaps into place on the arm (callout 2). The link actuates the fuser pressure-release mechanism.

Figure 1-517 Install the pressure-release link

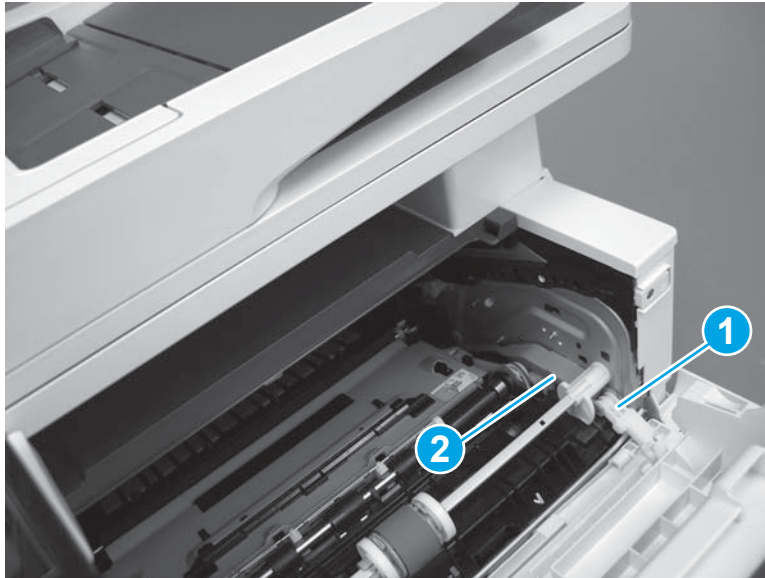

4. Slide the guide into the printer (callout 1), and then make sure that the tab (callout 2) snaps into place to secure the guide to the chassis.

Figure 1-518 Install the guide

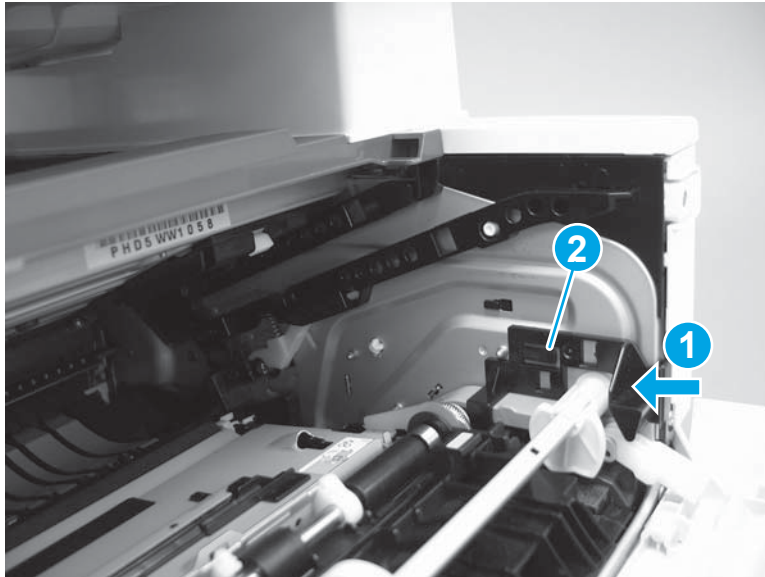

5. Position the shaft on the door, and then align the left-side hinge on the door with the hole in the chassis (callout 1).

Figure 1-519 Align the hinge

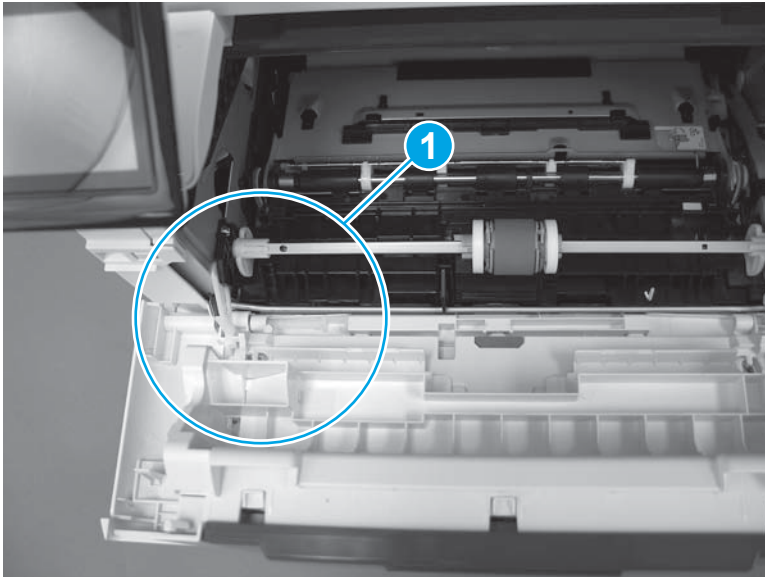

6. Push the shaft towards the left side of the printer to install it (callout 1).

 **Reinstallation tip:** Make sure that the support shaft is fully installed and correctly orientated (callout 2) so that it will not interfere with the door opening and closing.

Figure 1-520 Install the support shaft



Step 19: Install Tray 2

- ▲ Slide the tray straight into the printer to install it.

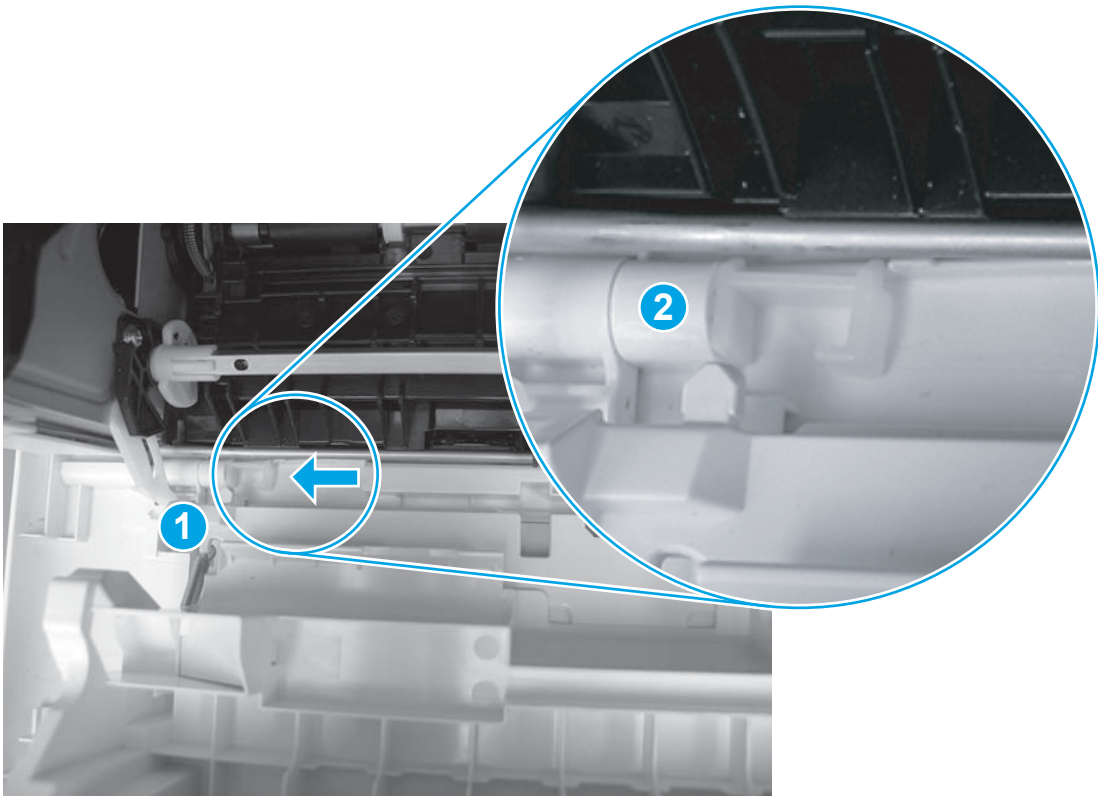
Figure 1-521 Install the tray



Removal and replacement: Integrated scanner assembly (M427/M426)



NOTE: M427/M426 models only. The integrated scanner assembly (ISA) includes the sub-scanner assembly (SSA) and the automatic document feeder (ADF).

- [Introduction](#)
- [Step 1: Remove Tray 2](#)
- [Step 2: Remove the cartridge door assembly](#)
- [Step 3: Remove the left cover](#)
- [Step 4: Remove the ISA \(M427/M426\)](#)
- [Step 5: Unpack the replacement assembly](#)
- [Step 6: Install the ISA \(M427/M426\)](#)
- [Step 7: Install the left cover](#)
- [Step 8: Install the cartridge door assembly](#)
- [Step 9: Install Tray 2](#)

Introduction

This document provides the procedures to remove and replace the ISA.

Before performing service

Turn the printer power off

- Disconnect the power cable.



WARNING! To avoid damage to the printer, turn the printer off, wait 30 seconds, and then remove the power cable before attempting to service the printer.

Use the table below to identify the correct part number for your printer. To order the part, go to www.hp.com/buy/parts.

ISA part number ¹	
C5F98-60110	ADF/scanner assembly, duplex ADF
C5F98-60109	ADF/scanner assembly, simplex ADF

¹ The ISA includes the SSA and the ADF.

Required tools

- #2 Phillips screwdriver with a magnetic tip.

After performing service

Turn the printer power on

- Connect the power cable.
- Use the power switch to turn the power on.

Post service test

Make sure that the printer initializes to a **Ready** state.

Print a configuration page, and then make a copy using the document feeder to make sure that it is properly functioning.

Step 1: Remove Tray 2

- ▲ Pull the tray straight out of the printer to remove it.

Figure 1-522 Remove the tray



Step 2: Remove the cartridge door assembly



NOTE: If the toner cartridge was not removed prior to servicing the printer, remove it now.

1. Release one tab (callout 1), and then slide shaft (callout 2) in the direction the arrow indicates and remove it.



TIP: It might be easier to release the support shaft by using a small flat-blade screwdriver.

Figure 1-523 Release the support shaft

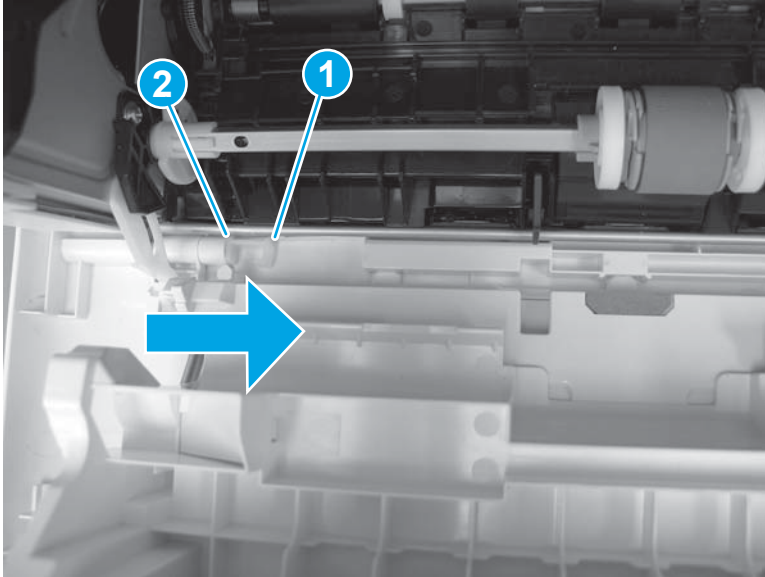

2. Release one tab (callout 1), and then slide the guide (callout 2) in the direction the arrow indicates and remove it.

Figure 1-524 Remove the guide

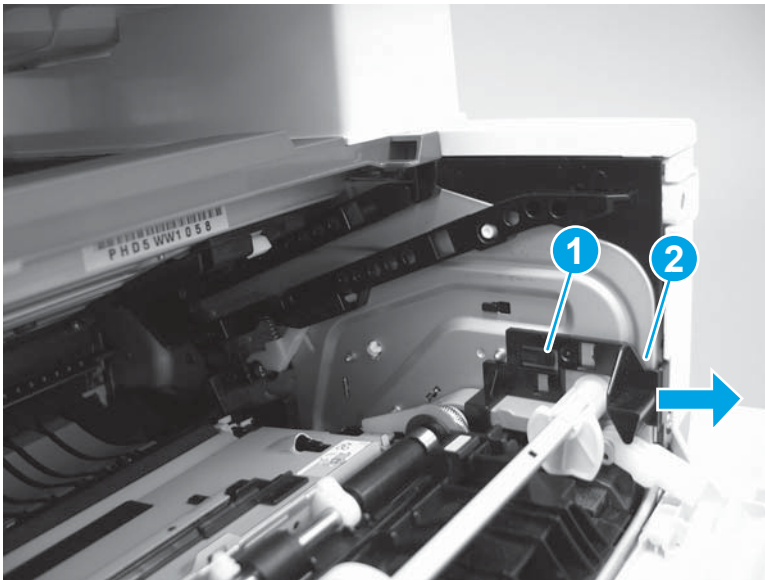

3. Remove the link arm (callout 1).

Figure 1-525 Remove the link arm

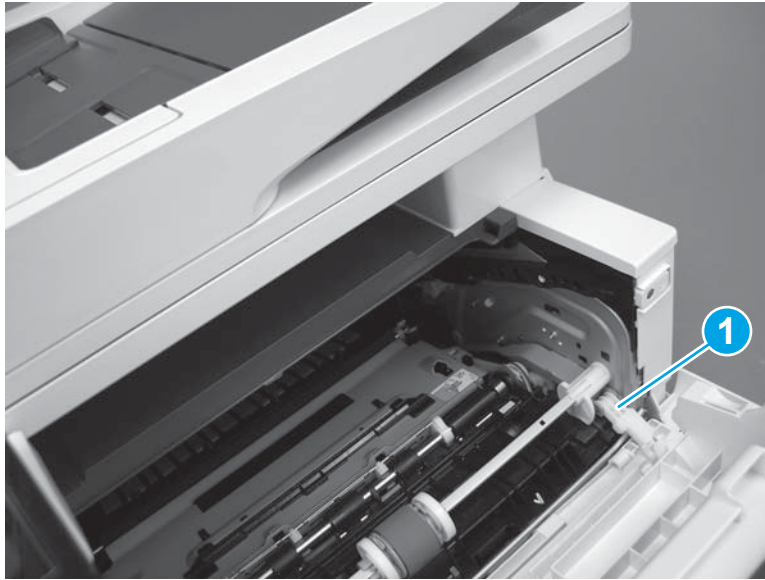

4. Slide the cartridge door assembly (callout 1) in the direction the arrow indicates and remove it.

Figure 1-526 Remove the door

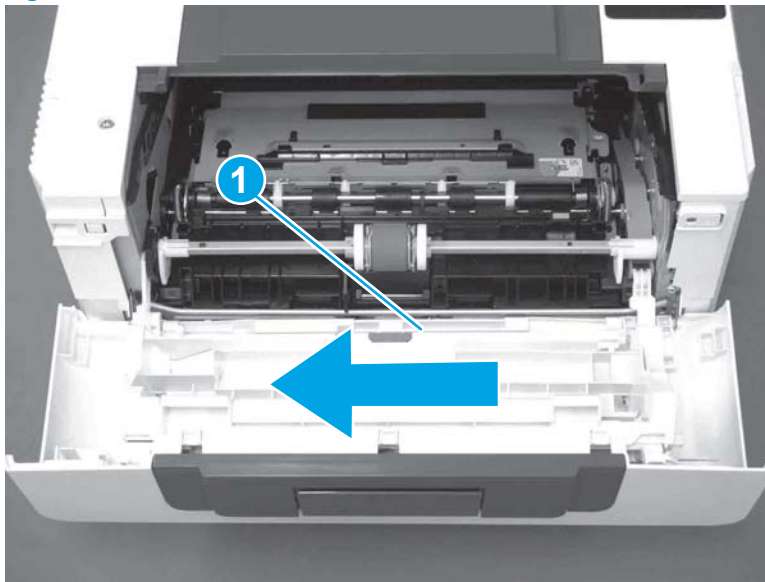

5. Remove the link (callout 1) from the cartridge door assembly (callout 2).

Figure 1-527 Release the left-side retainer arm

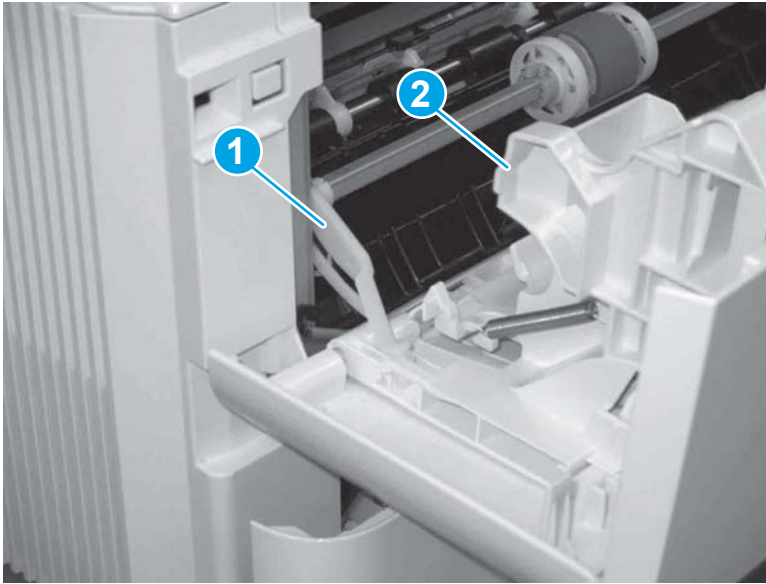

Step 3: Remove the left cover

1. Remove one screw (callout 1).

Figure 1-528 Remove one screw

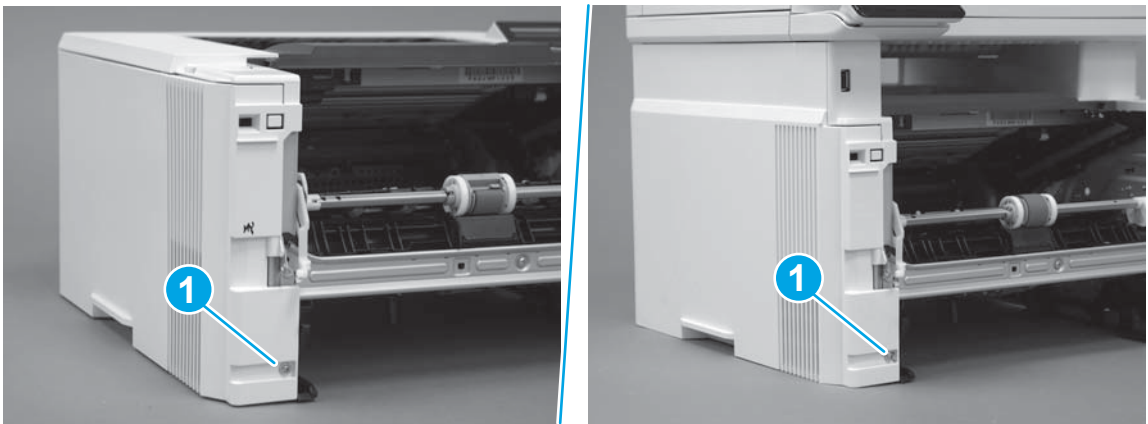

2. Open the rear door, release two bosses (callout 1), and then release three tabs (callout 2).

Figure 1-529 Release two bosses and three tabs

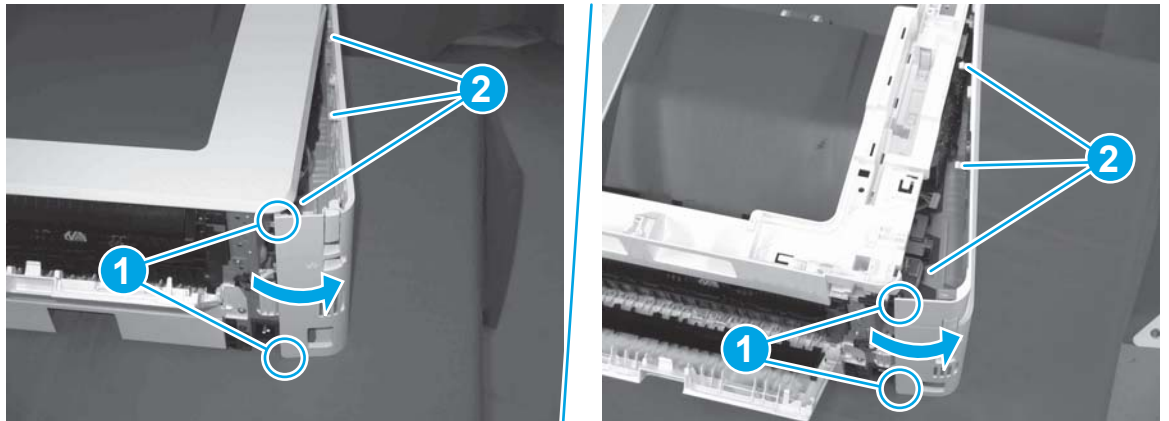

3. At the front of the printer, do one of the following:
 - **M403/M402:** Release two bosses (callout 1), and then remove the cover (callout 2).
 - **M427/M426:** Release one tab (callout 3), two bosses (callout 4), and then remove the cover (callout 5).

CAUTION: Be careful when releasing the upper bosses on the M427/M426 cover. One portion of the cover (callout 6) is fragile and is easily broken.

Figure 1-530 Remove the cover

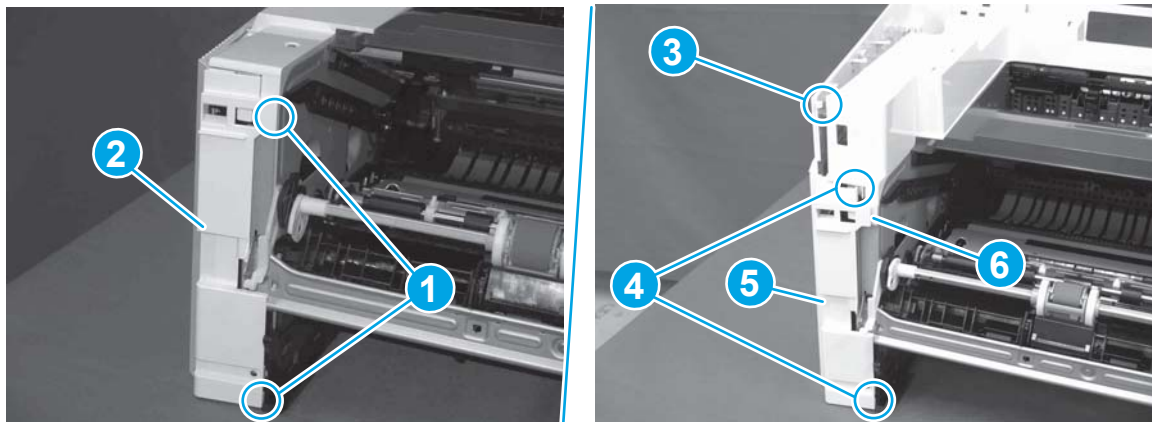

Step 4: Remove the ISA (M427/M426)

NOTE: M427/M426 models only. The integrated scanner assembly (ISA) includes the sub-scanner assembly (SSA) and the automatic document feeder (ADF).

1. Raise the ISA.

Figure 1-531 Raise the ISA

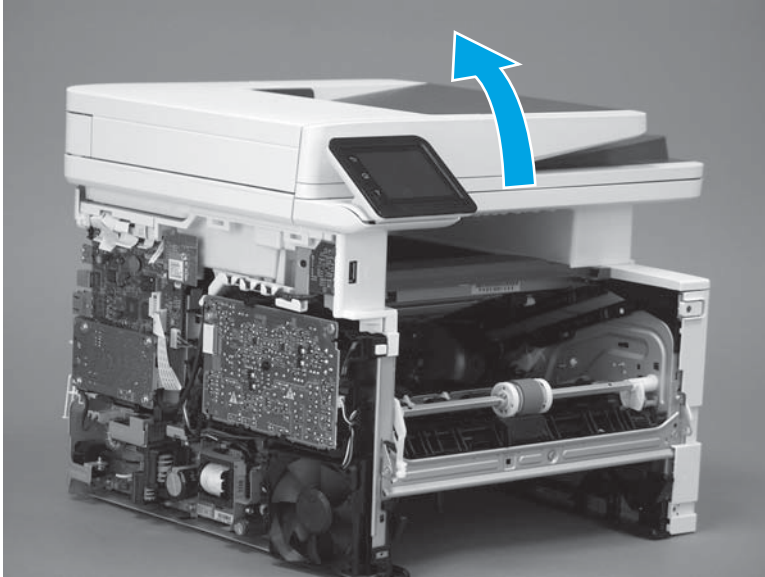

2. Release the ISA flat-flexible cable (FFC) cover (callout 1), and then remove it (callout 2).

Figure 1-532 Remove the ISA FFC cover

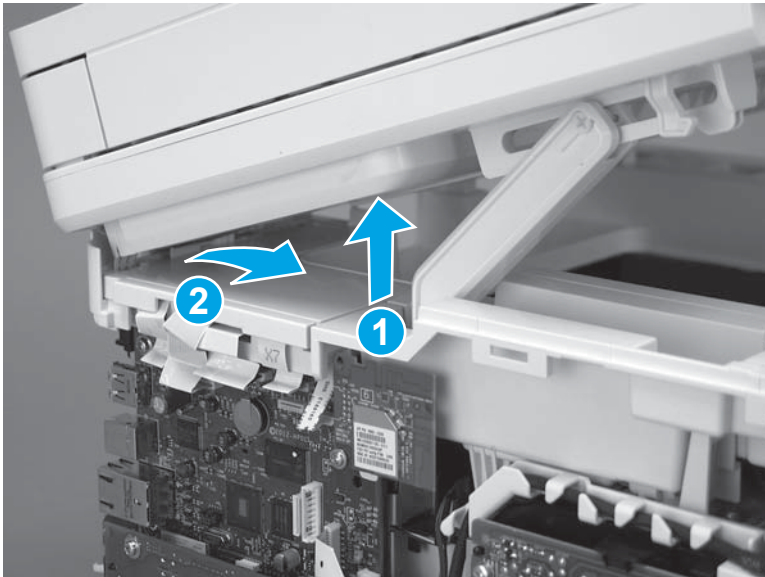

3. Disconnect three FFCs (callout 1), and then remove the ferrite (callout 2) from the holder.

CAUTION: The ferrite is not captive on the FFC. Do not lose the ferrite while handling the ISA.

Figure 1-533 Disconnect three FFCs

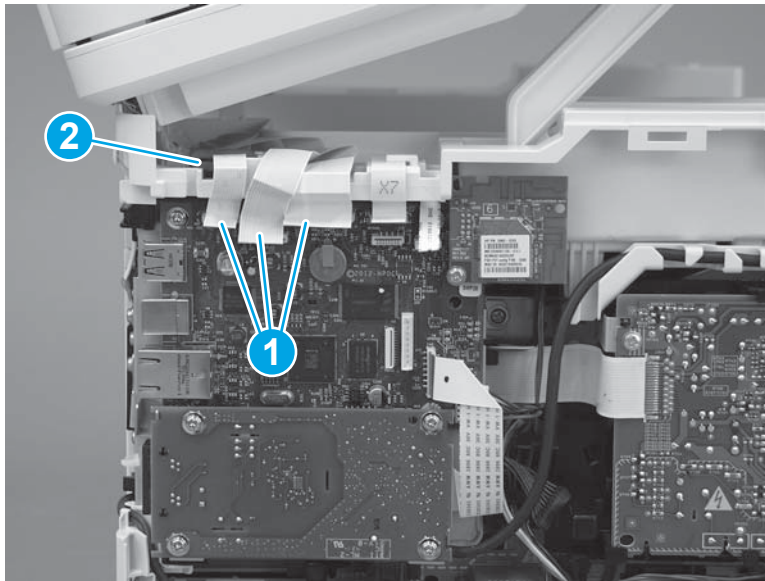

4. Remove one screw (callout 1).

Figure 1-534 Remove one screw

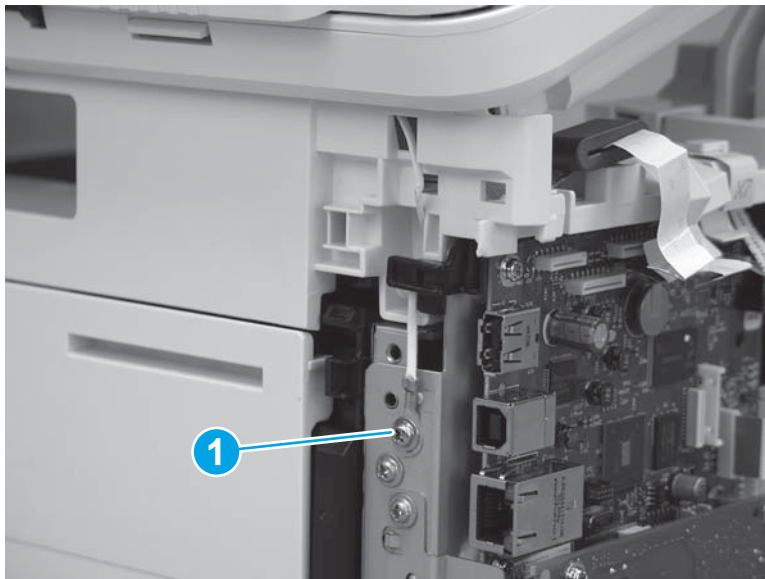

5. Pass the ground wire through the opening in the top cover.

Figure 1-535 Pass the wire through the opening

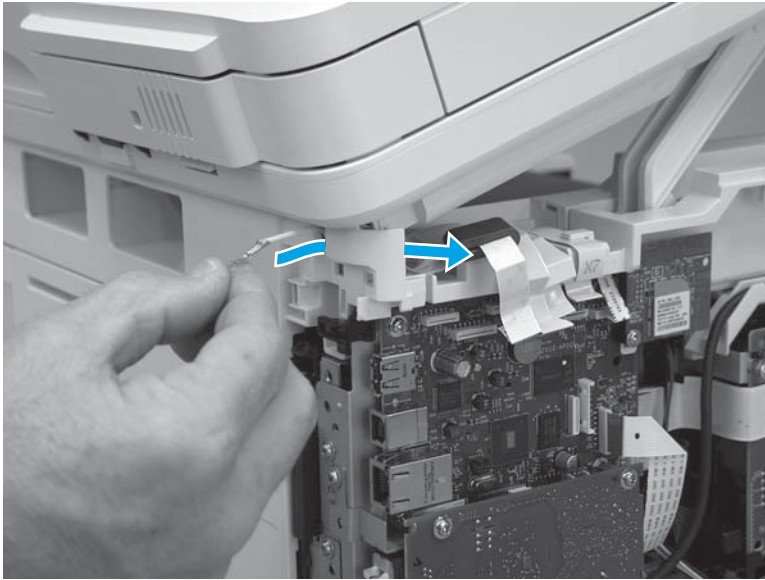

6. Release one tab (callout 1), and then rotate the ISA slider pin (callout 2) towards the front of the printer to release it.

Figure 1-536 Release one tab and rotate the slider pin

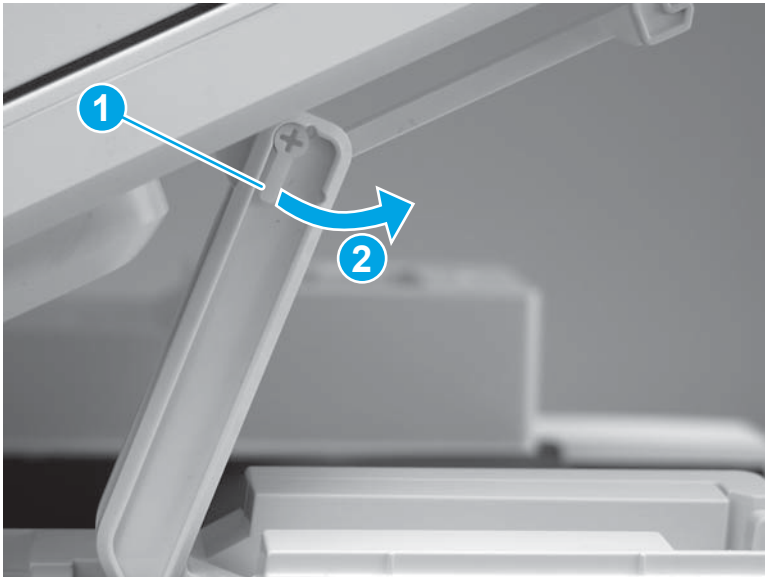

7. Remove the slider pin.

Figure 1-537 Remove the slider pin

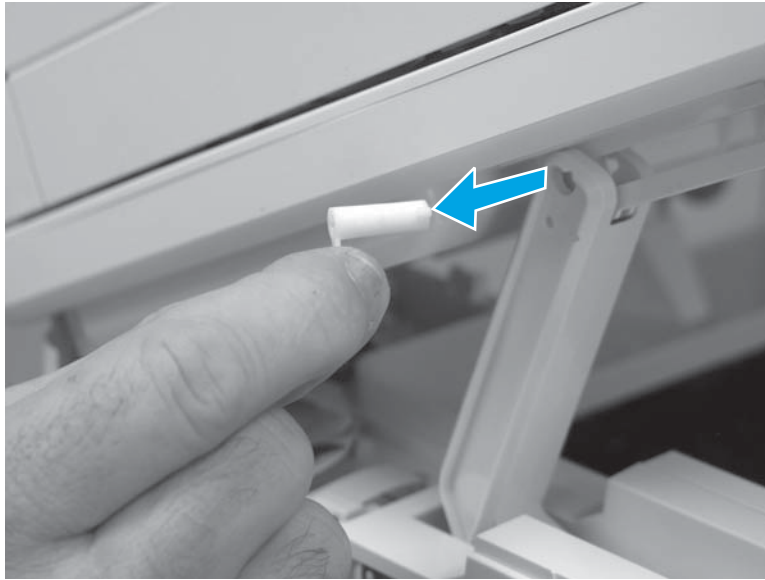

8. Rotate the ISA towards the rear of the printer until it stops.

Figure 1-538 Rotate the ISA towards the rear of the printer



9. Slide the ISA as shown to release it.

Figure 1-539 Release the ISA

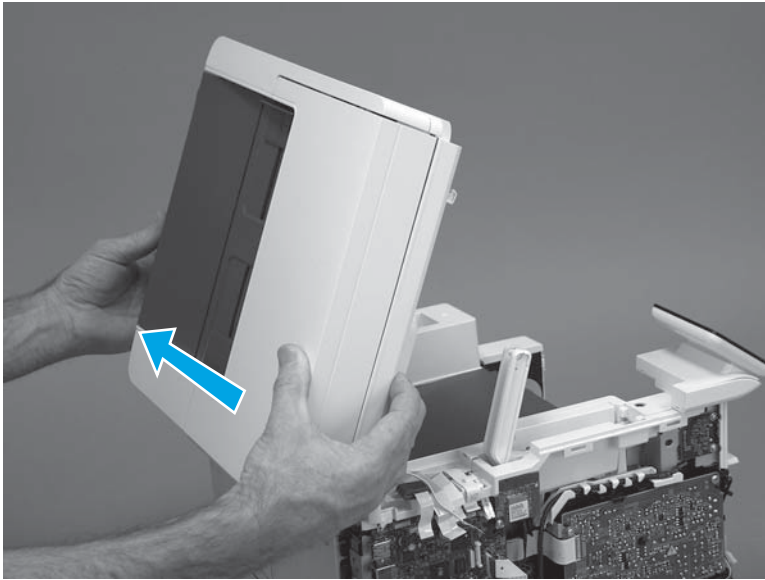

10. Remove the ISA.

Figure 1-540 Remove the ISA

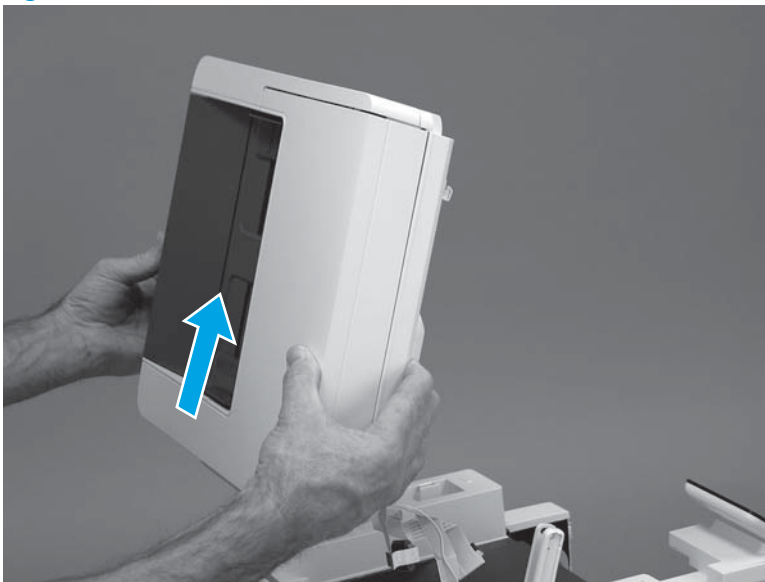

Step 5: Unpack the replacement assembly

Unpack the replacement part from the packaging.

<http://www8.hp.com/us/en/hp-information/environment/product-recycling.html>



NOTE: HP recommends responsible disposal of the defective part.

Figure 1-541 Recycle and unpack

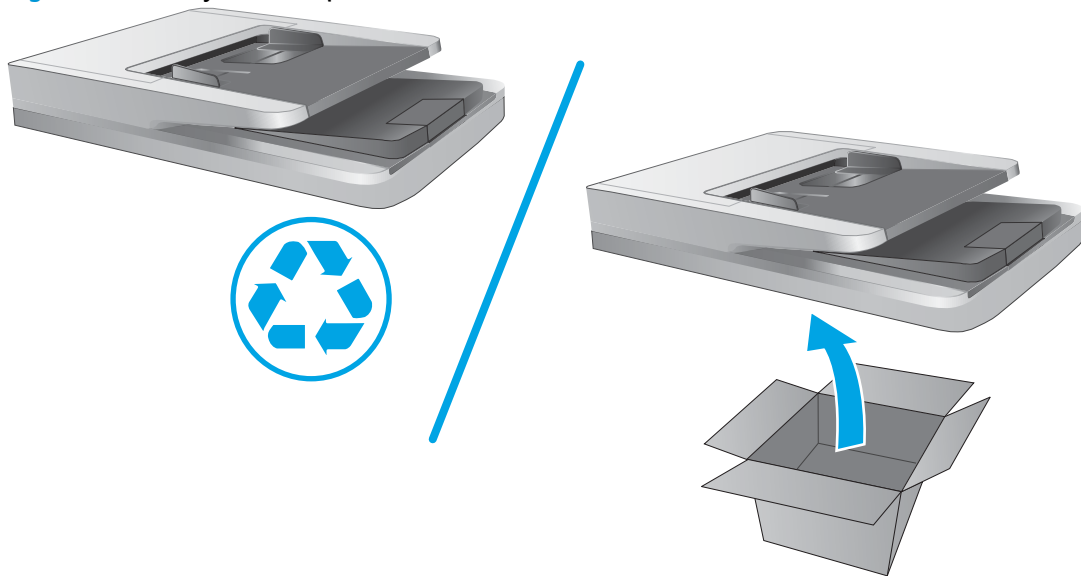

Step 6: Install the ISA (M427/M426)

 **NOTE:** M427/M426 models only. The integrated scanner assembly (ISA) includes the sub-scanner assembly (SSA) and the automatic document feeder (ADF).

1. Position the ISA on the printer.

Figure 1-542 Position the ISA on the printer

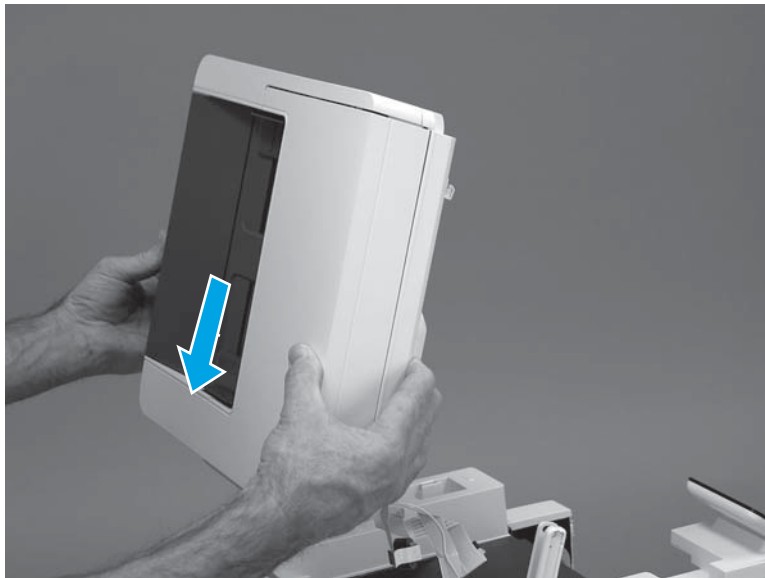

2. Engage the hinge pins on the ISA with the holders in the top cover (callouts 1/2), and then slide the ISA as shown to engage them

Figure 1-543 Engage the hinge pins with the holders

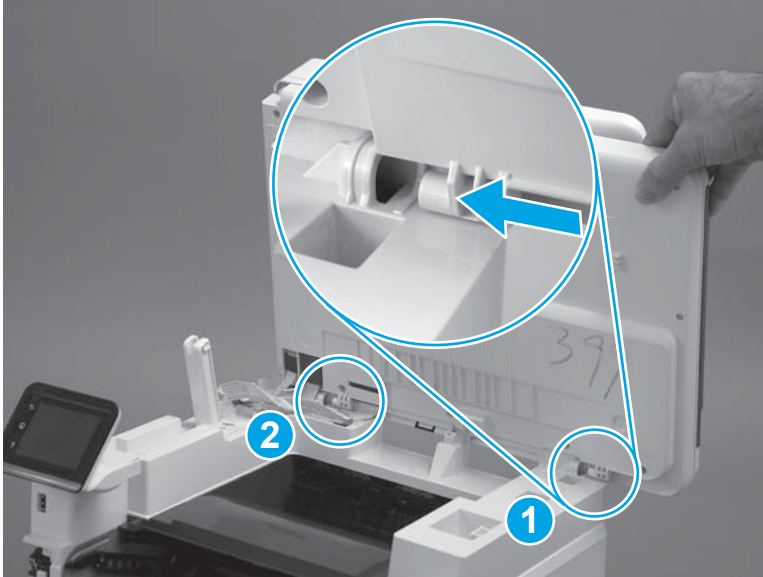

3. Rotate the ISA towards the front of the printer until it rests on the ISA lift assembly (callout 1).

Figure 1-544 Rotate the ISA towards the front of the printer



4. Pass the ground wire through the opening in the top cover.

Figure 1-545 Pass the wire through the opening

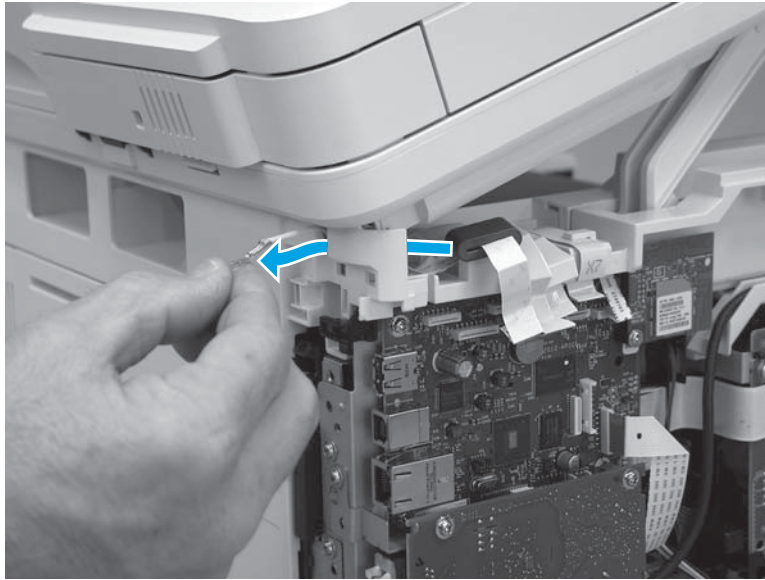

5. Install one screw (callout 1).

Figure 1-546 Install one screw

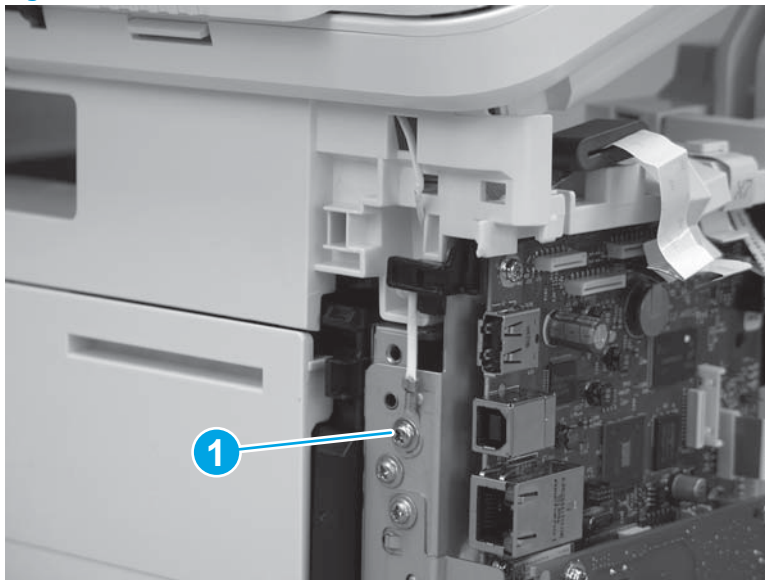

6. Install the ISA lift assembly slider pin.

 **Reinstallation tip:** Align the keyed portion of the locking pin with the slot and hole in the support arm.

Figure 1-547 Install the slider pin



7. Rotate the slider pin (callout 1) towards the rear of the printer until the tab (callout 2) snap into place.

Figure 1-548 Secure the slider pin

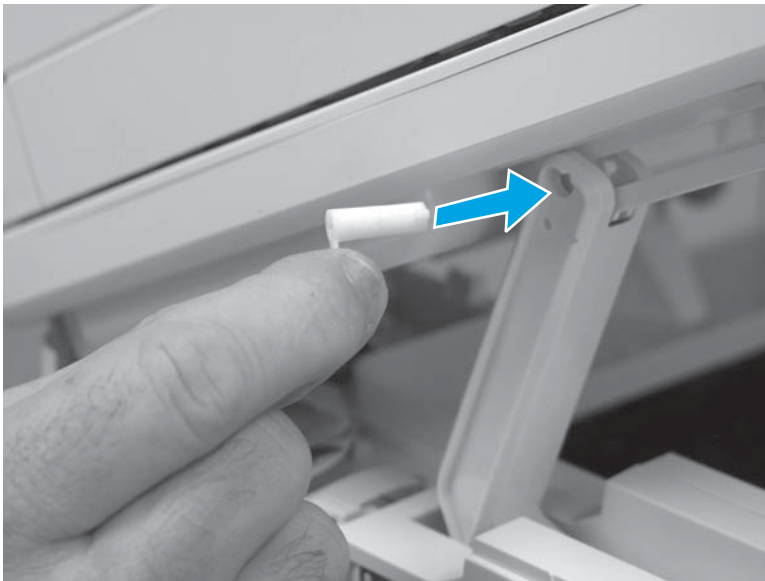
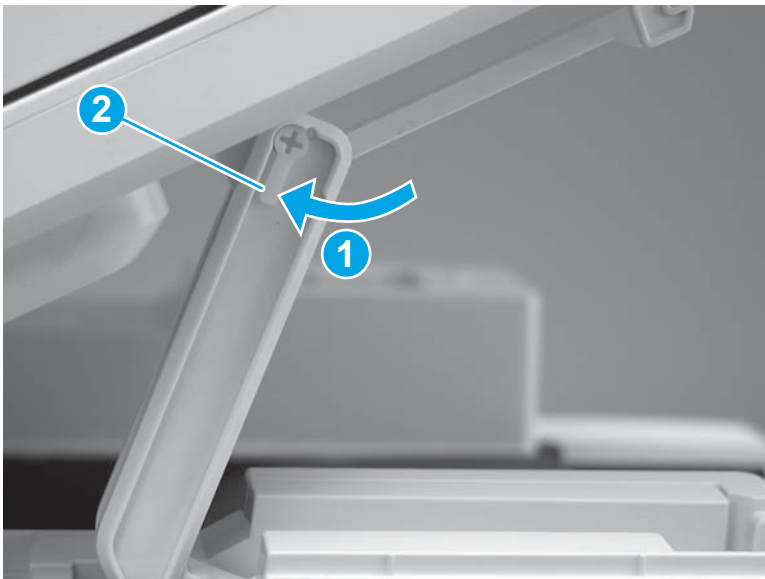

8. Install the ferrite (callout 1) in the holder, and then connect three FFCs (callout 2).

Figure 1-549 Connect three FFCs

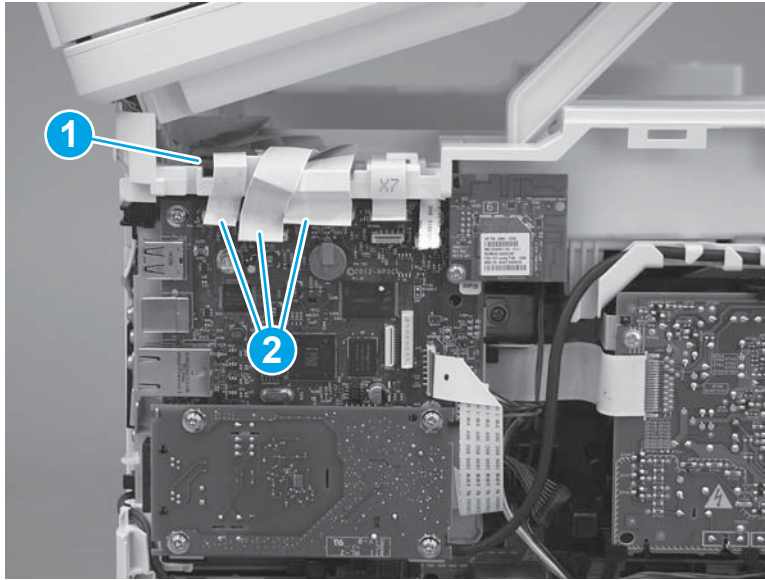

9. Position the rear edge of the ISA flat-flexible cable (FFC) cover on the printer (callout 1), and then rotate it down (callout 2) until it snaps into place.

Figure 1-550 Install the ISA FFC cover

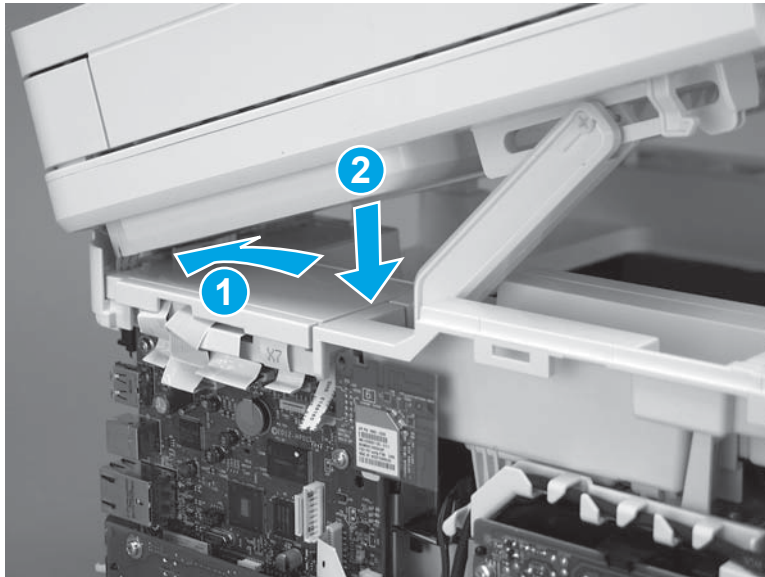

10. Lower the ISA.

Figure 1-551 Lower the ISA

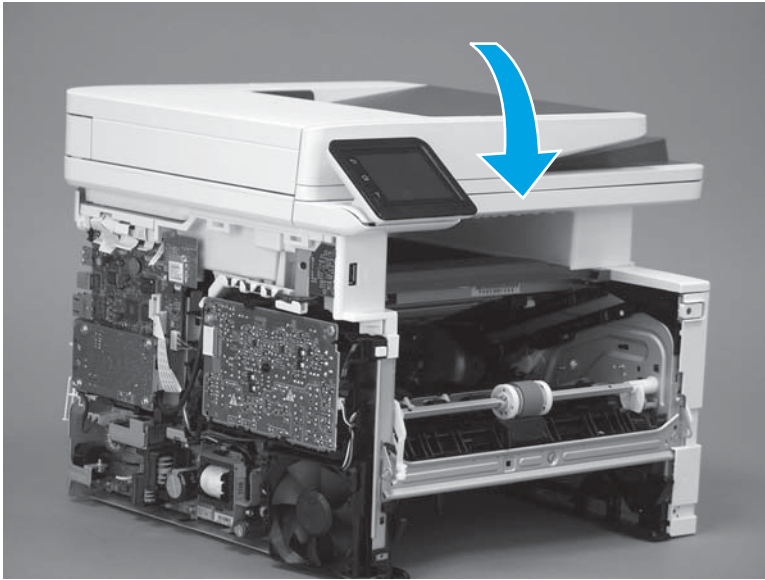

Step 7: Install the left cover

1. At the front of the printer, do one of the following:
 - **M403/M402:** Position the cover on the printer (callout 1), and then engage two bosses (callout 2).
 - **M427/M426:** Position the cover on the printer (callout 3), engage one tab (callout 4), and then engage two bosses (callout 4).

Figure 1-552 Install the cover

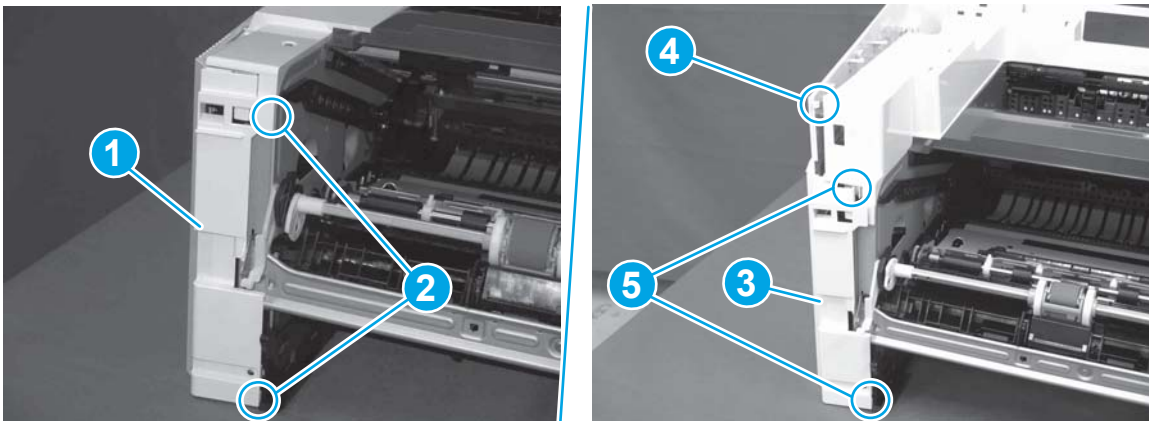

- Carefully rotate the rear of the cover onto the printer (callout 1), engage three tabs (callout 2), and then engage two bosses (callout 3).

Figure 1-553 Engage three tabs and two bosses

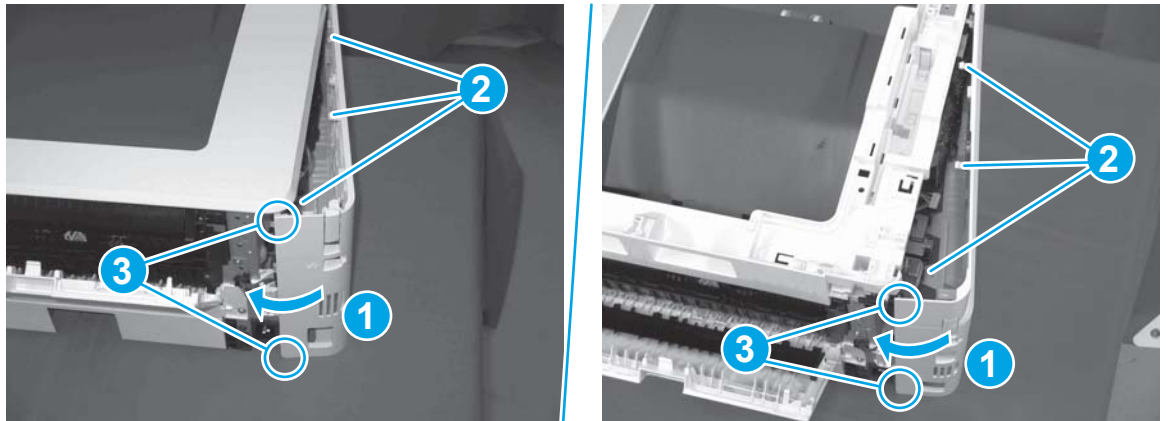

- Install one screw (callout 1).

Figure 1-554 Install one screw

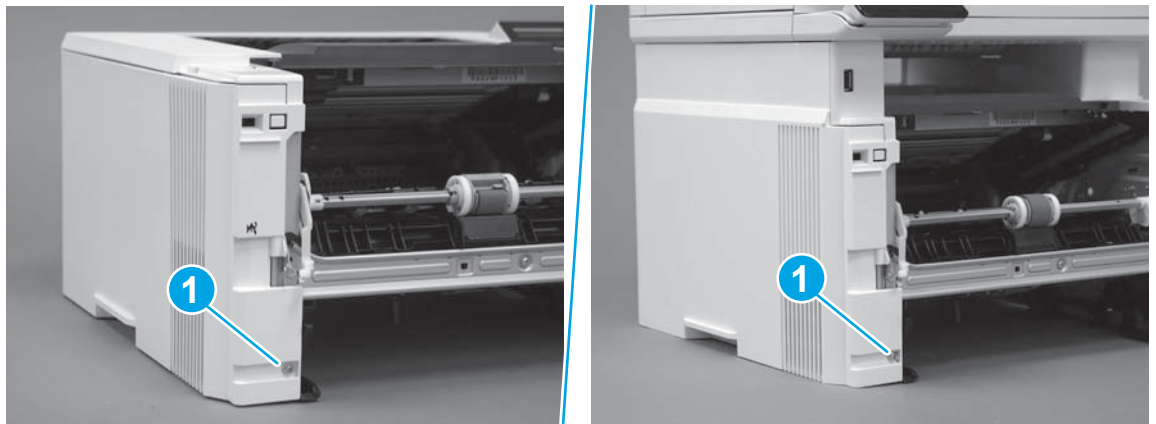

Step 8: Install the cartridge door assembly

 **Reinstallation tip:** After a replacement door is installed, make sure to install the nameplate (supplied in the kit) corresponding to the printer name on the door.

- Position the door close to the printer, and then engage the keyed pin on the left-side retainer arm with the hole in the door.

Figure 1-555 Engage the left-side retainer arm

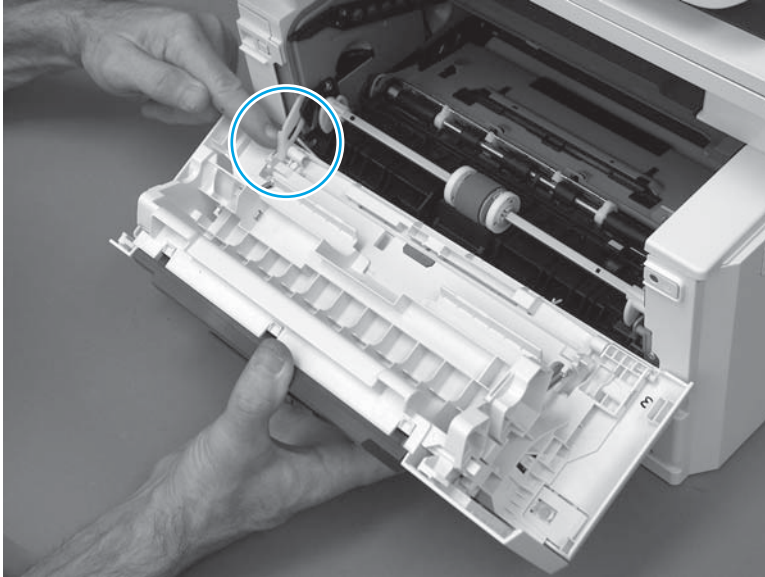

2. Engage the right-side door hinge pin with the hole in the chassis (callout 1).

Figure 1-556 Install the door

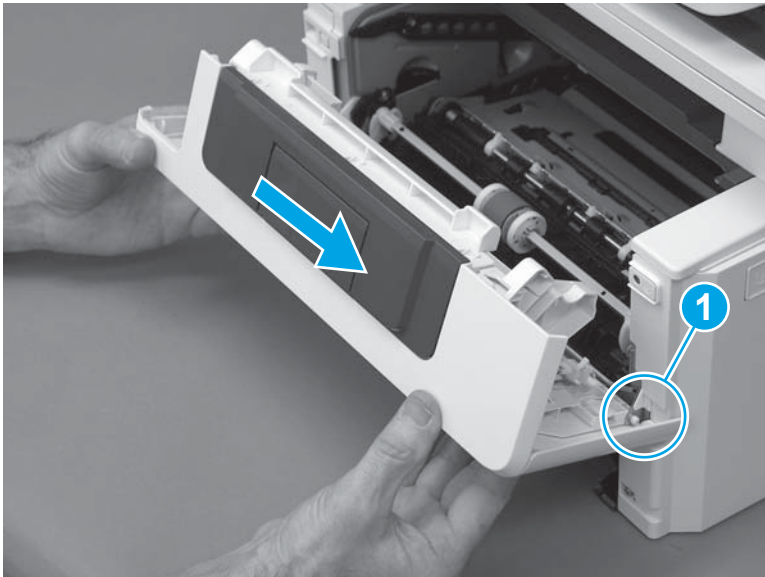

3. Install the link (callout 1).

 **IMPORTANT:** Make sure that the link snaps into place on the arm (callout 2). The link actuates the fuser pressure-release mechanism.

Figure 1-557 Install the pressure-release link

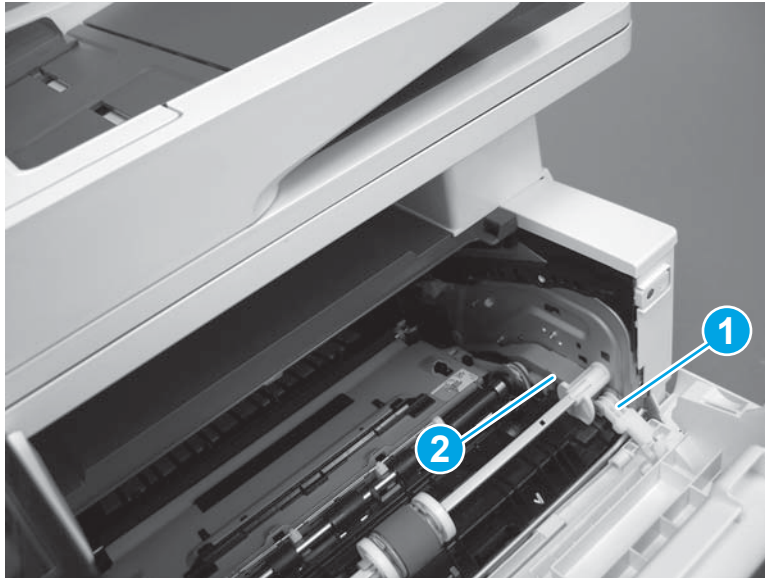

4. Slide the guide into the printer (callout 1), and then make sure that the tab (callout 2) snaps into place to secure the guide to the chassis.

Figure 1-558 Install the guide

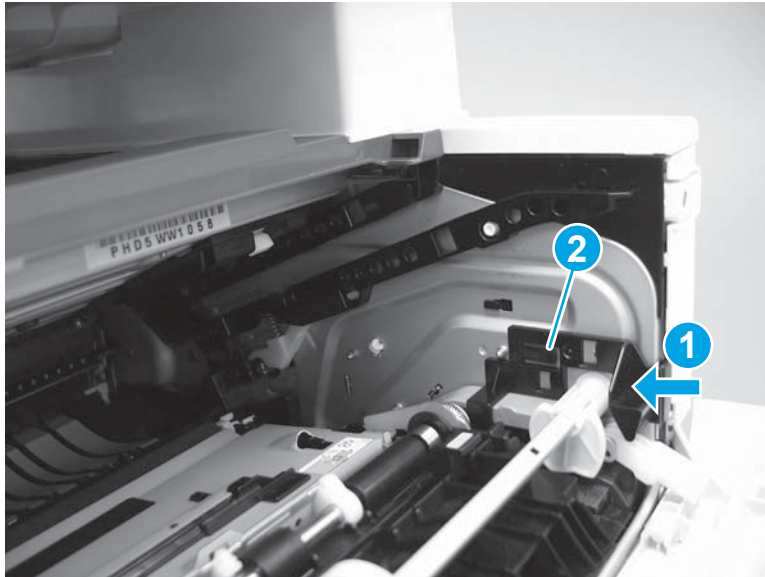

5. Position the shaft on the door, and then align the left-side hinge on the door with the hole in the chassis (callout 1).

Figure 1-559 Align the hinge

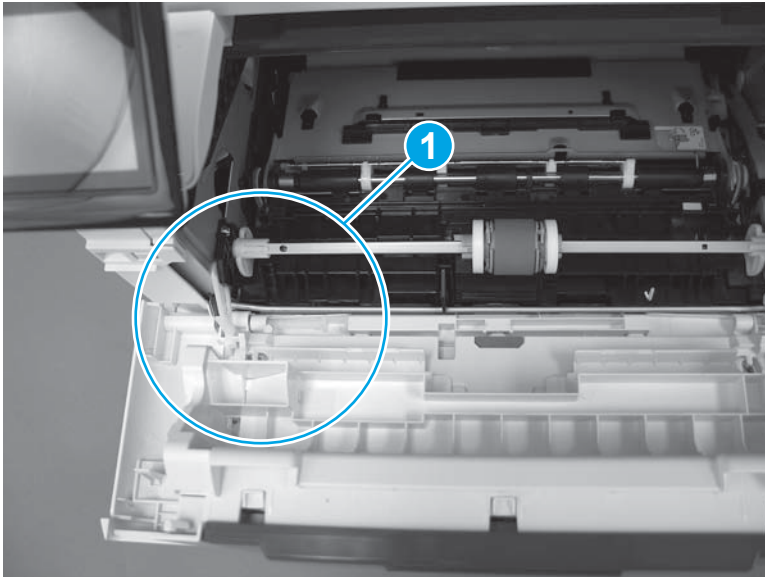

6. Push the shaft towards the left side of the printer to install it (callout 1).

 **Reinstallation tip:** Make sure that the support shaft is fully installed and correctly orientated (callout 2) so that it will not interfere with the door opening and closing.

Figure 1-560 Install the support shaft



Step 9: Install Tray 2

- ▲ Slide the tray straight into the printer to install it.

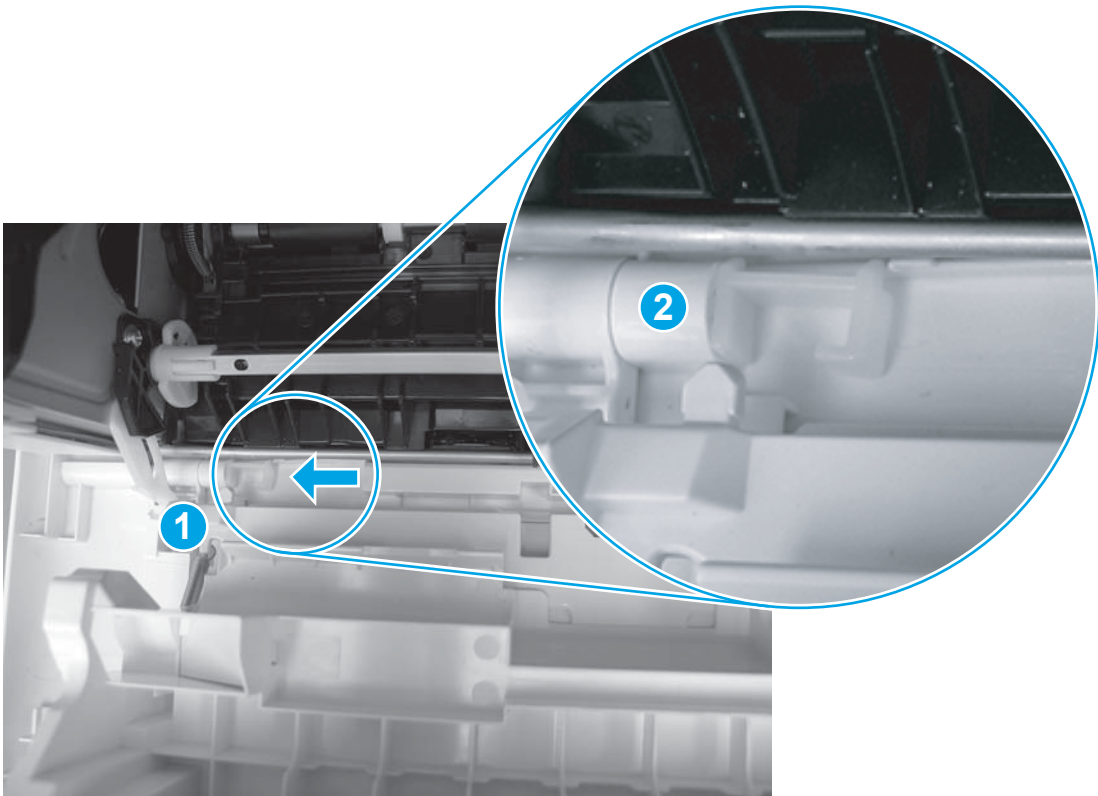
Figure 1-561 Install the tray



Removal and replacement: ISA lift assembly and slider pin (M427/M426)

 **NOTE:** M427/M426 models only.

- [Introduction](#)
- [Step 1: Remove the slider pin \(M427/M426\)](#)
- [Step 2: Remove the ISA lift assembly \(M427/M426\)](#)
- [Step 3: Unpack the replacement assembly](#)
- [Step 4: Install the ISA lift assembly \(M427/M426\)](#)
- [Step 5: Install the slider pin \(M427/M426\)](#)

Introduction

This document provides the procedures to remove and replace the integrated scanner assembly (ISA) support arm.

Before performing service

Turn the printer power off

- Disconnect the power cable.

 **WARNING!** To avoid damage to the printer, turn the printer off, wait 30 seconds, and then remove the power cable before attempting to service the printer.

Use the table below to identify the correct part number for your printer. To order the part, go to www.hp.com/buy/parts.

ISA lift assembly and slider pin

83Q10-60128	ISA lift assembly
83Q10-40041	Slider pin, ISA lift assembly

Required tools

- #2 Phillips screwdriver with a magnetic tip.

After performing service

Turn the printer power on

- Connect the power cable.
- Use the power switch to turn the power on.

Post service test

Make sure that the printer initializes to a **Ready** state.

Print a configuration page, and then make a copy using the document feeder to make sure that it is properly functioning.

Step 1: Remove the slider pin (M427/M426)

1. Open the ISA, release one tab (callout 1), and then rotate the ISA slider pin (callout 2) towards the front of the printer to release it.

Figure 1-562 Release one tab and rotate the slider pin

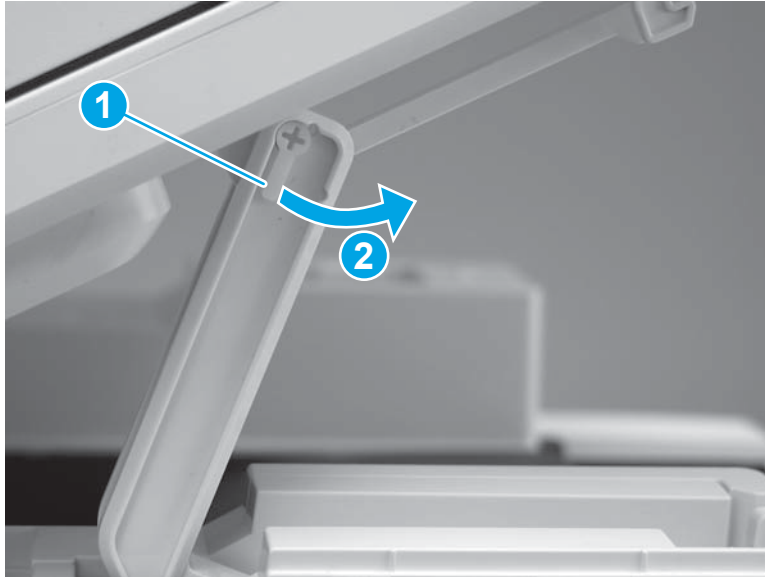

2. Remove the slider pin.

Figure 1-563 Remove the slider pin

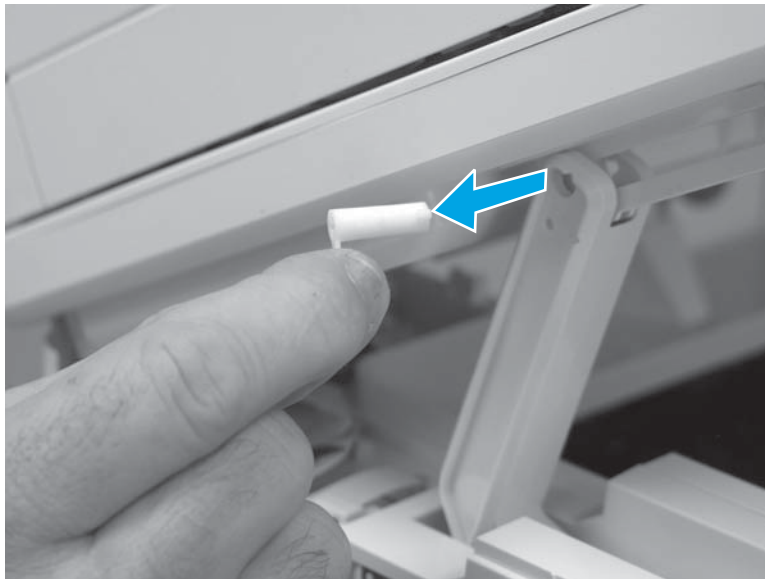

Step 2: Remove the ISA lift assembly (M427/M426)

1. Move the ISA out of the way, and then lower the support arm to the closed position.

CAUTION: The ISA hinges are not captive in the top cover mounting bosses. Do not allow the ISA to slip off of the top cover.

Figure 1-564 Lower the support arm

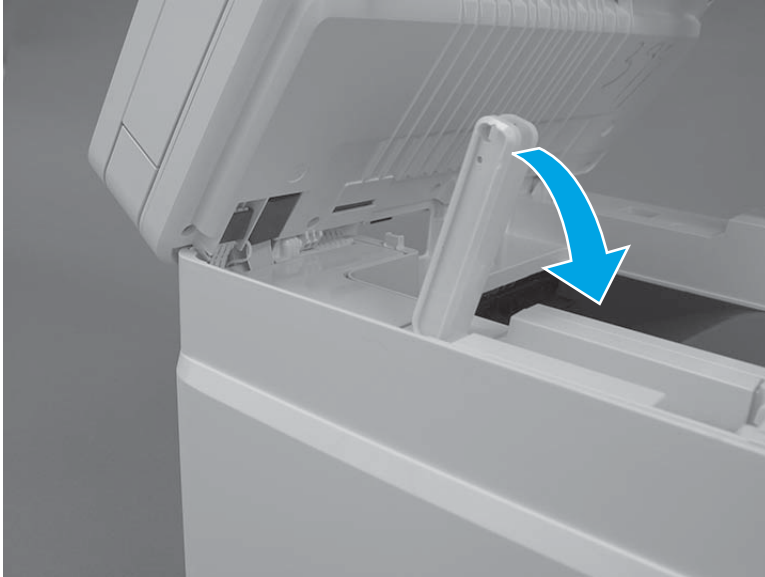

2. Before proceeding take note of the following.

⚠ CAUTION: The support arm is spring loaded and can unexpectedly spring into the open position. To avoid injury, do not place a finger in the screw well when the support arm is in the closed position.

Figure 1-565 Before proceeding take note

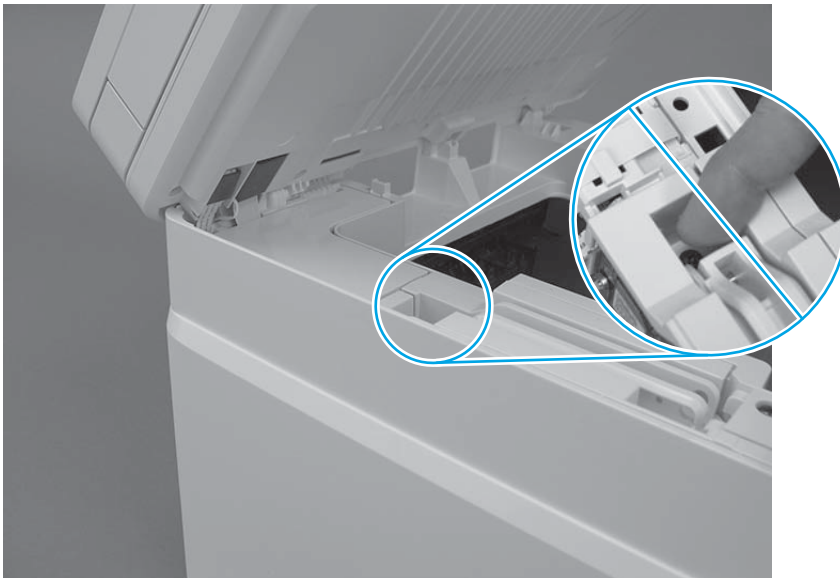

3. Remove one screw (callout 1).

Figure 1-566 Remove one screw

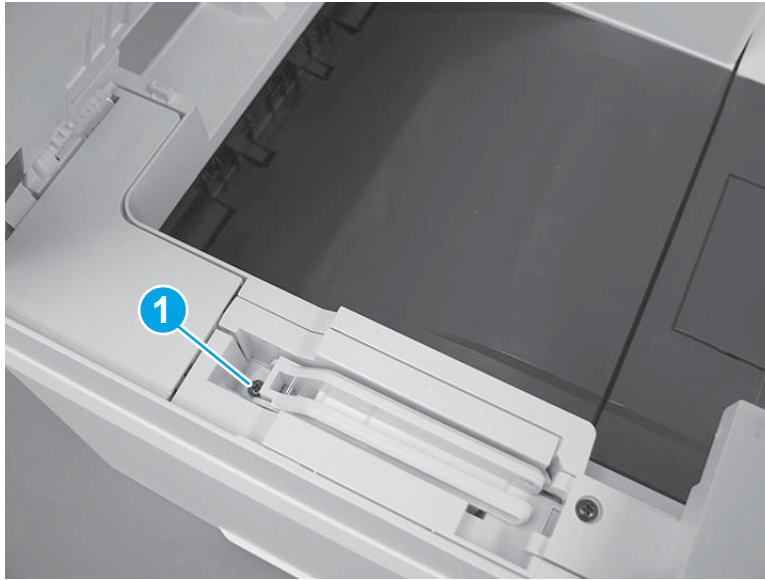

4. Remove the support arm.

Figure 1-567 Remove the support arm

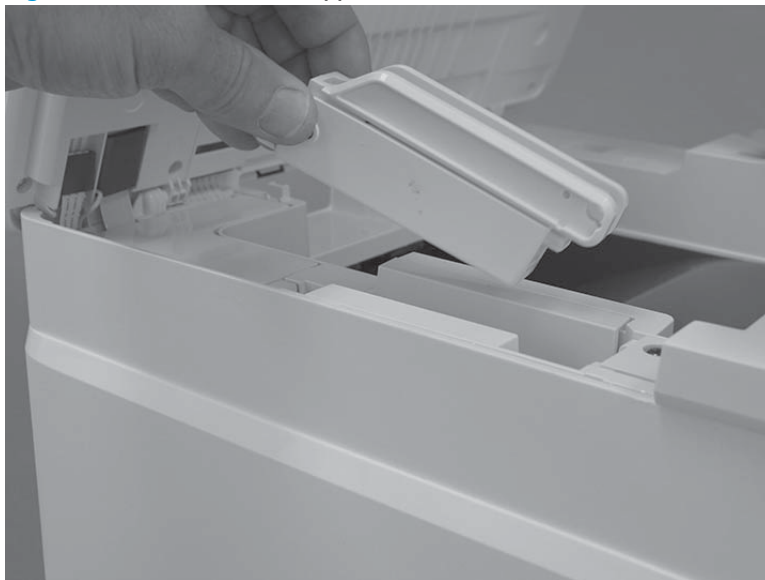

Step 3: Unpack the replacement assembly

Unpack the replacement part from the packaging.

<http://www8.hp.com/us/en/hp-information/environment/product-recycling.html>

 **NOTE:** HP recommends responsible disposal of the defective part.

Figure 1-568 Recycle and unpack

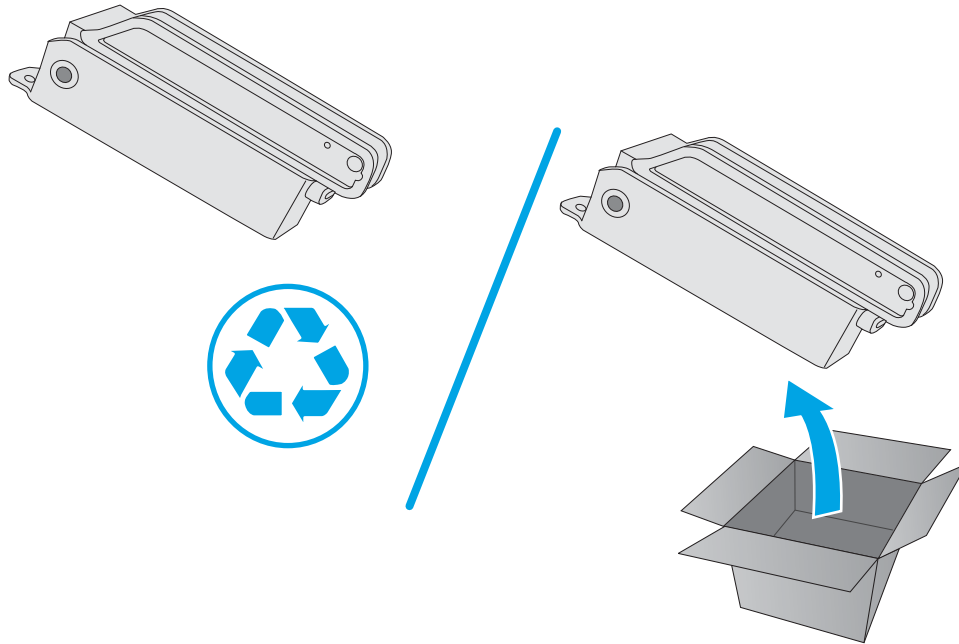

Step 4: Install the ISA lift assembly (M427/M426)

1. Support the ISA, align the tab (callout 1) on the lift assembly with the slot in the top cover (callout 2), and then install the lift assembly.

CAUTION: The ISA hinges are not captive in the top cover mounting bosses. Do not allow the ISA to slip off of the top cover.

NOTE: If the replacement lift assembly is in the closed position, place it in the open position.

Figure 1-569 Install the lift assembly

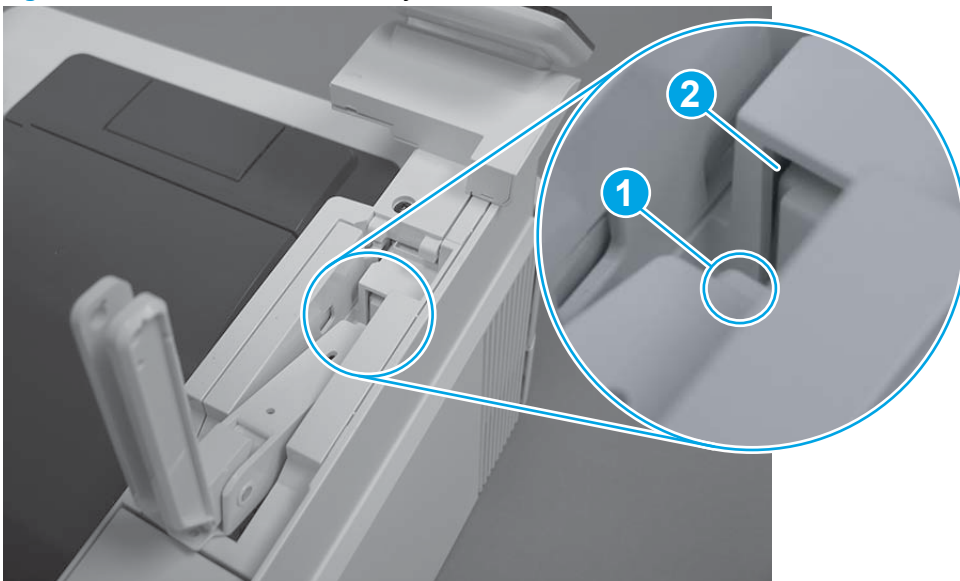

2. Lower the lift assembly to the closed position.

Figure 1-570 Lower the lift assembly

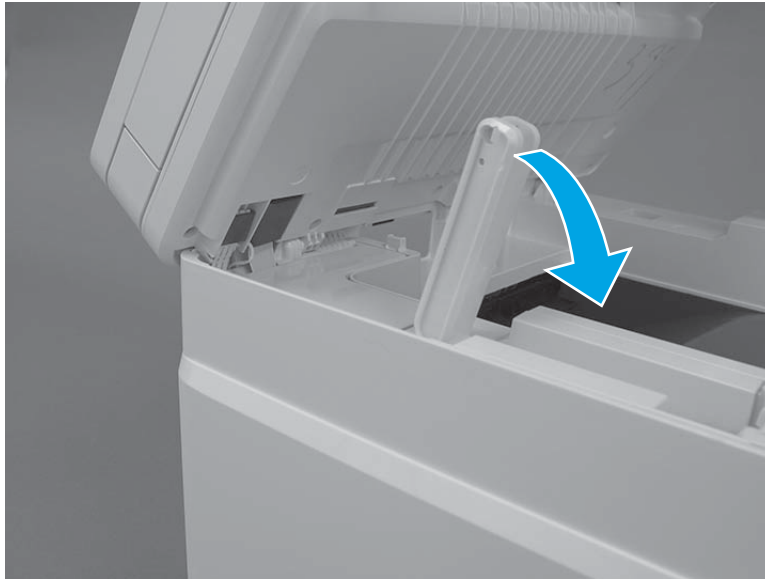

3. Before proceeding take note of the following.

⚠ CAUTION: The lift assembly is spring loaded and can unexpectedly spring into the open position. To avoid injury, do not place a finger in the screw well when the lift assembly is in the closed position.

Figure 1-571 Before proceeding take note

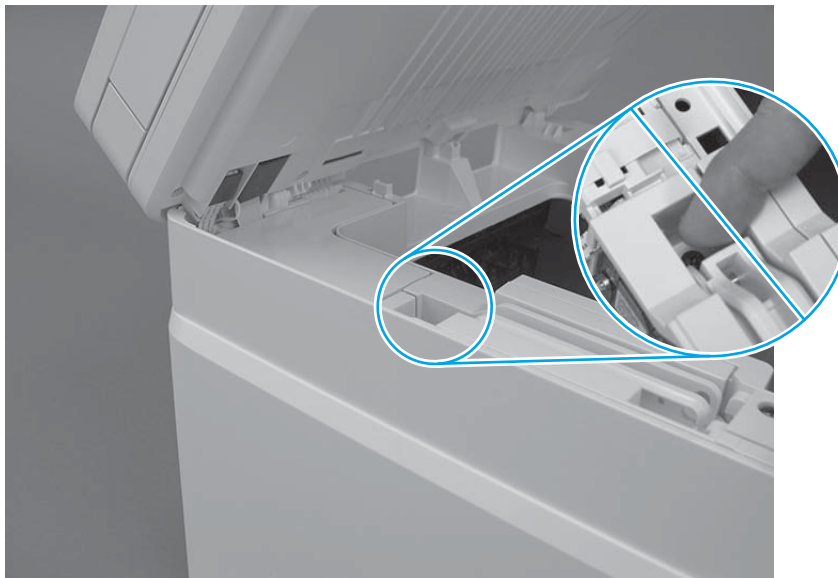

4. Install one screw (callout 1).

Figure 1-572 Install one screw

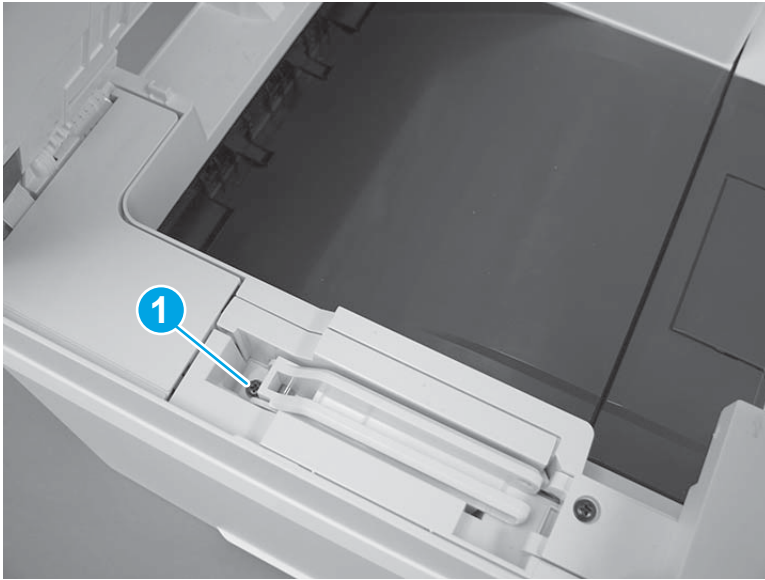

Step 5: Install the slider pin (M427/M426)

1. Raise the ISA lift assembly to the open position, engage the ISA with the lift assembly, and then install the slider pin.

 **Reinstallation tip:** Align the keyed portion of the slider pin with the slot and hole in the lift assembly.

Figure 1-573 Install the slider pin



2. Rotate the slider pin (callout 1) towards the rear of the printer until the tab (callout 2) snap into place. Close the ISA.

Figure 1-574 Secure the slider pin

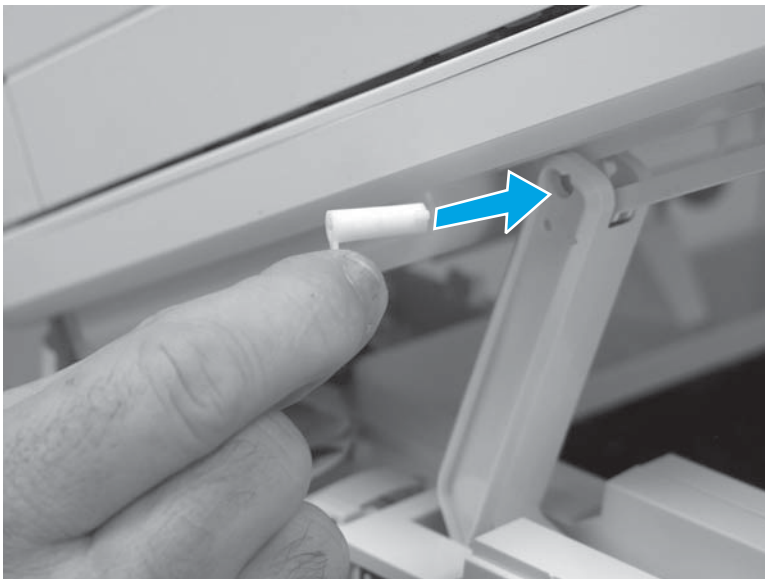
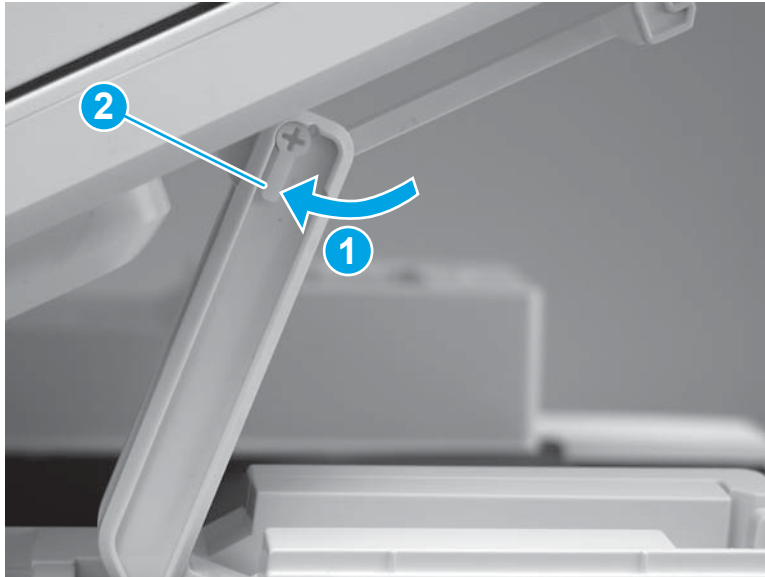

Removal and replacement: Internal parts and assemblies

- [Removal and replacement: Fuser](#)
- [Removal and replacement: Registration assembly](#)
- [Removal and replacement: Main motor \(M1\)](#)
- [Removal and replacement: Power switch printed circuit assembly](#)
- [Removal and replacement: Fax PCA \(M427/M426\)](#)
- [Removal and replacement: Walkup USB PCA \(M427/M426\)](#)
- [Removal and replacement: Wireless PCA](#)
- [Removal and replacement: Formatter PCA](#)
- [Removal and replacement: Fan \(FM1\)](#)
- [Removal and replacement: Fan holder \(FM1\)](#)
- [Removal and replacement: Laser scanner assembly](#)
- [Removal and replacement: Sheet-metal formatter bracket and formatter PCA](#)
- [Removal and replacement: NFC FFC](#)
- [Removal and replacement: Control panel FFC, \(M403/M402\)](#)
- [Removal and replacement: Formatter FFC](#)
- [Removal and replacement: DC controller](#)
- [Removal and replacement: Tag-cable assembly \(toner-cartridge memory\)](#)
- [Removal and replacement: Connecting PCA](#)
- [Removal and replacement: Laser scanner FFC](#)
- [Removal and replacement: High-voltage power supply](#)
- [Removal and replacement: Low-voltage power supply](#)
- [Removal and replacement: NFC cover \(M427/M426\)](#)
- [Removal and replacement: NFC PCA](#)
- [Removal and replacement: Control-panel assembly \(M403/M402\)](#)
- [Removal and replacement: Control panel \(M427/M426\) and control panel sub assemblies](#)

Removal and replacement: Fuser

- [Introduction](#)
- [Step 1: Remove Tray 2](#)
- [Step 2: Remove the cartridge door assembly](#)
- [Step 3: Remove the left cover](#)
- [Step 4: Remove the right cover](#)
- [Step 5: Remove the rear door assembly](#)
- [Step 6: Remove the fuser](#)
- [Step 7: Unpack the replacement assembly](#)
- [Step 8: Install the fuser](#)
- [Step 9: Install the rear door assembly](#)
- [Step 10: Install the right cover](#)
- [Step 11: Install the left cover](#)
- [Step 12: Install the cartridge door assembly](#)
- [Step 13: Install Tray 2](#)

Introduction

This document provides the procedures to remove and replace the fuser.

Before performing service

Turn the printer power off

- Disconnect the power cable.

⚠ WARNING! To avoid damage to the printer, turn the printer off, wait 30 seconds, and then remove the power cable before attempting to service the printer.

Make sure the correct voltage fuser is installed in the printer.

⚠ CAUTION: The fuser is hot. Wait at least 30 minutes after turning the printer off before removing the fuser.

Use the table below to identify the correct part number for your printer. To order the part, go to www.hp.com/buy/parts.

Fuser part number	
RM2-5399-000CN	Fuser (110V/127V)
RM2-5425-000CN	Fuser (220V/240V)

Required tools

- #2 Phillips screwdriver with a magnetic tip.

After performing service

Turn the printer power on

- Connect the power cable.
- Use the power switch to turn the power on.

Post service test

Make sure that the printer initializes to a **Ready** state.

Print a configuration page to make sure that the printer is functioning correctly.

Step 1: Remove Tray 2

- ▲ Pull the tray straight out of the printer to remove it.

Figure 1-575 Remove the tray



Step 2: Remove the cartridge door assembly



NOTE: If the toner cartridge was not removed prior to servicing the printer, remove it now.

1. Release one tab (callout 1), and then slide shaft (callout 2) in the direction the arrow indicates and remove it.



TIP: It might be easier to release the support shaft by using a small flat-blade screwdriver.

Figure 1-576 Release the support shaft

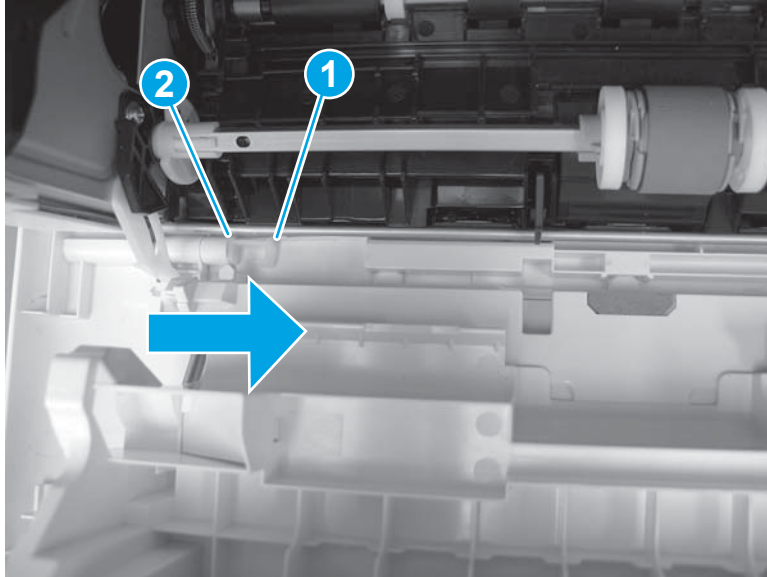

2. Release one tab (callout 1), and then slide the guide (callout 2) in the direction the arrow indicates and remove it.

Figure 1-577 Remove the guide

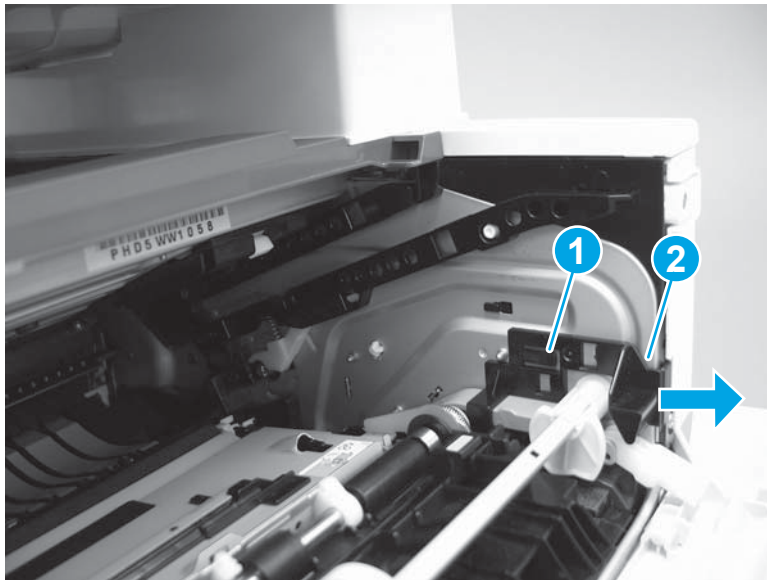

3. Remove the link arm (callout 1).

Figure 1-578 Remove the link arm

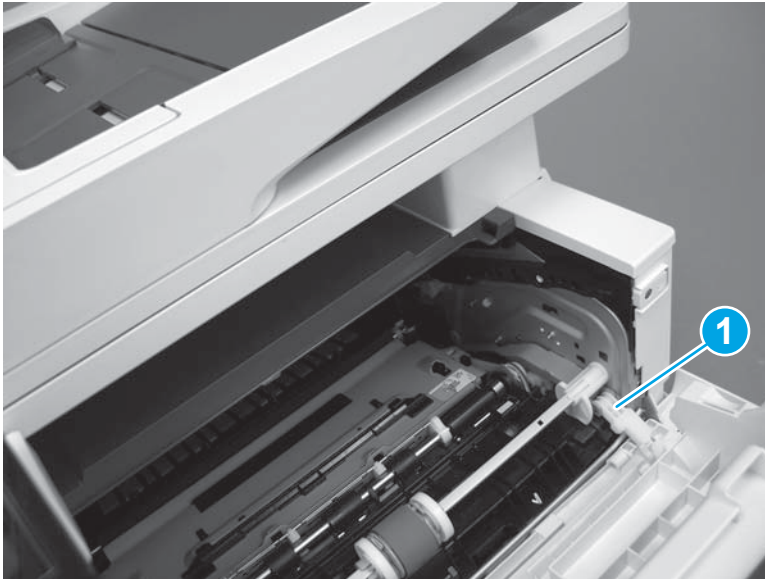

4. Slide the cartridge door assembly (callout 1) in the direction the arrow indicates and remove it.

Figure 1-579 Remove the door

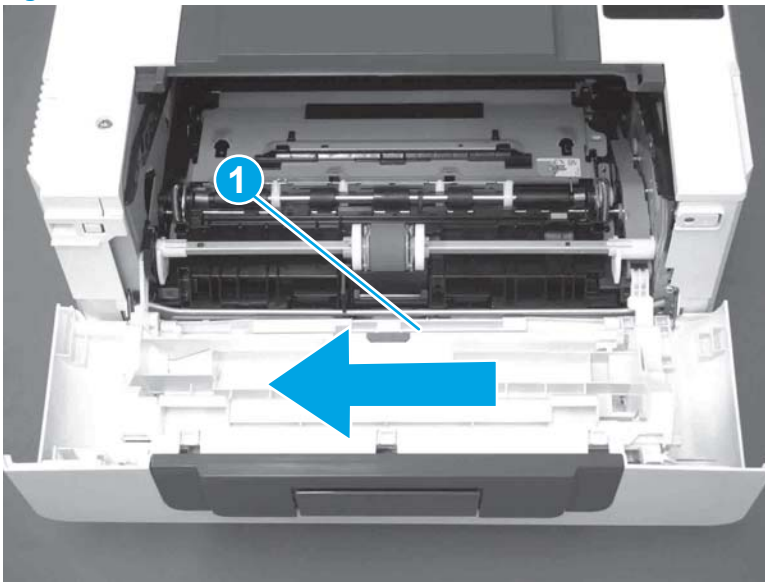

5. Remove the link (callout 1) from the cartridge door assembly (callout 2).

Figure 1-580 Release the left-side retainer arm

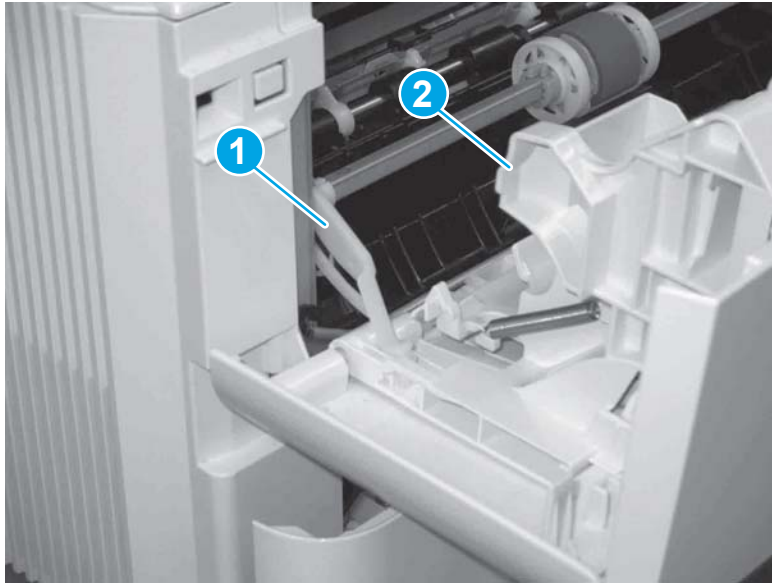

Step 3: Remove the left cover

1. Remove one screw (callout 1).

Figure 1-581 Remove one screw

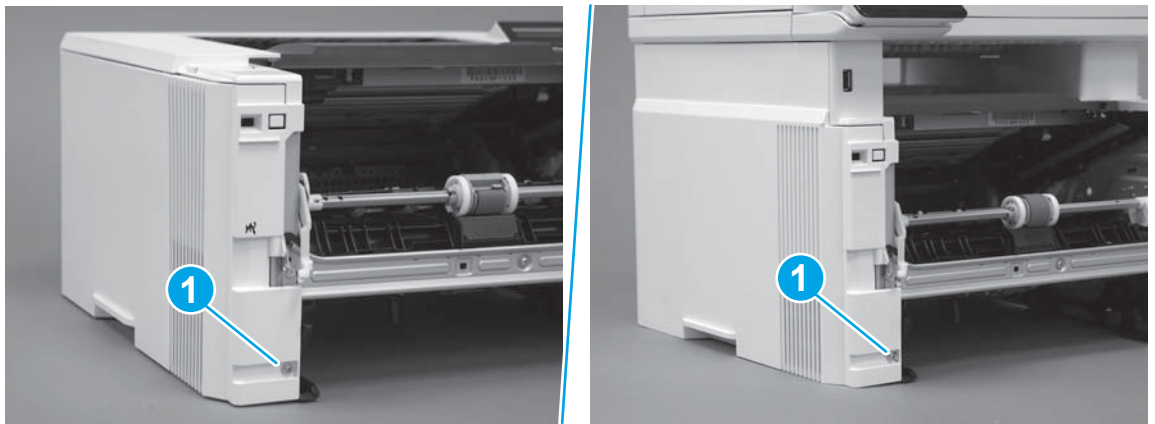

2. Open the rear door, release two bosses (callout 1), and then release three tabs (callout 2).

Figure 1-582 Release two bosses and three tabs

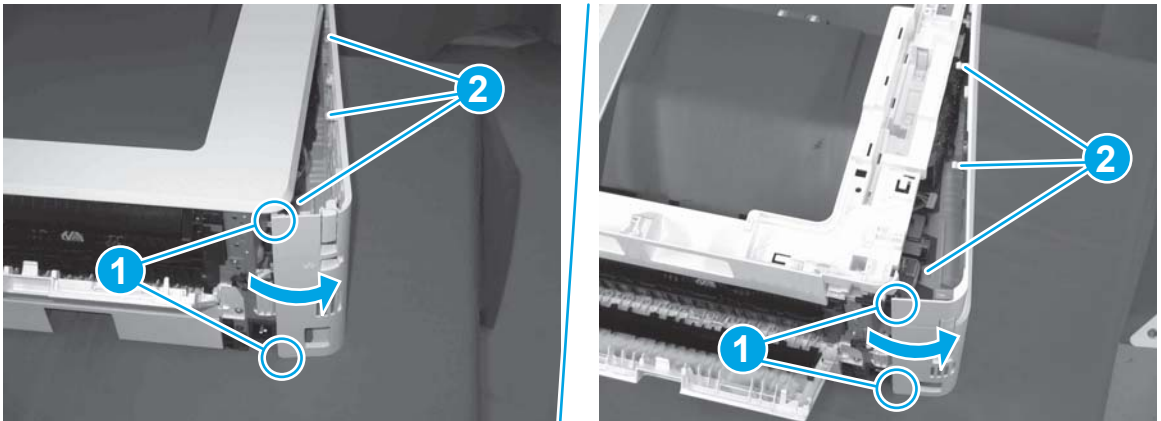

3. At the front of the printer, do one of the following:
 - **M403/M402:** Release two bosses (callout 1), and then remove the cover (callout 2).
 - **M427/M426:** Release one tab (callout 3), two bosses (callout 4), and then remove the cover (callout 5).

CAUTION: Be careful when releasing the upper bosses on the M427/M426 cover. One portion of the cover (callout 6) is fragile and is easily broken.

Figure 1-583 Remove the cover

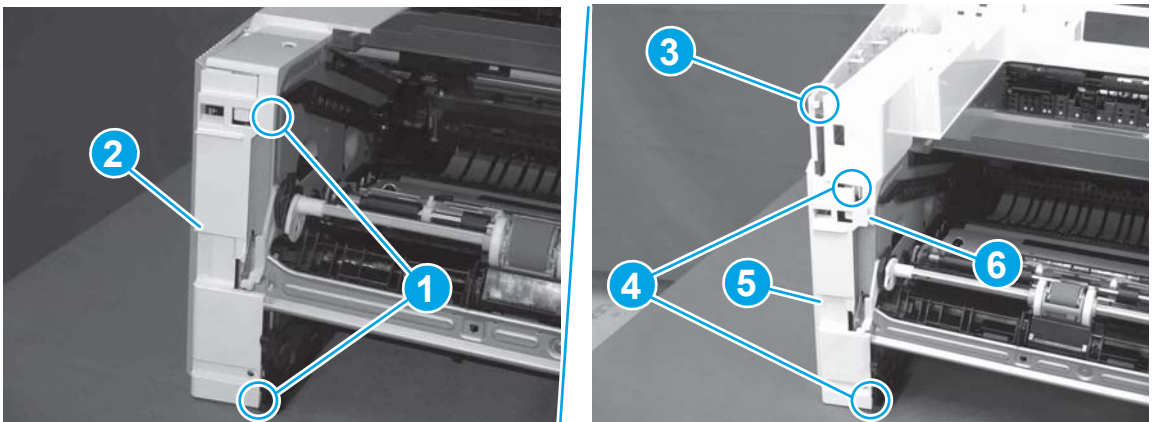

Step 4: Remove the right cover

1. Remove one screw (callout 1).

Figure 1-584 Remove one screw

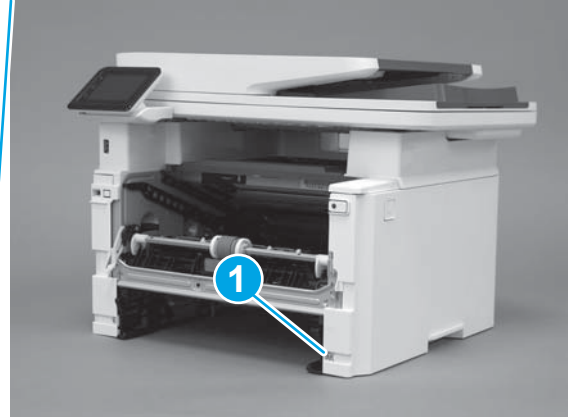
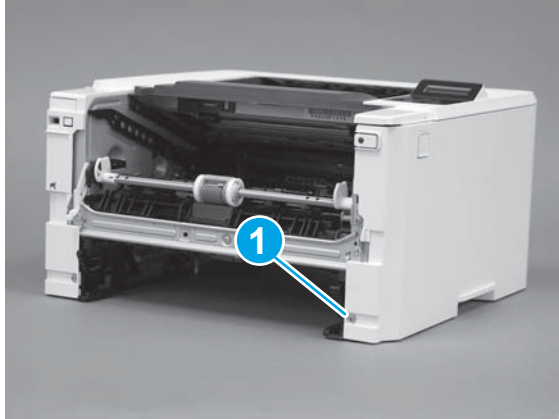

2. At the front of the printer, release two bosses (callout 1), and then release three tabs (callout 2).

Figure 1-585 Release two bosses and three tabs

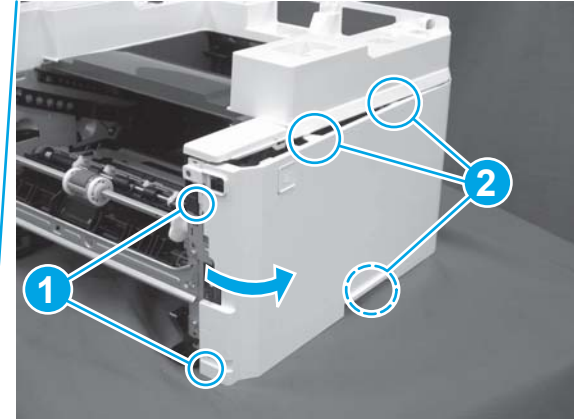
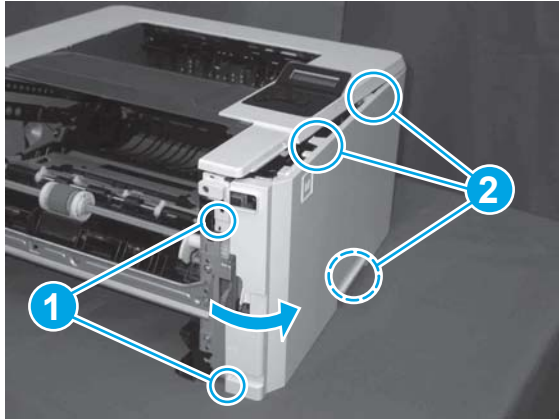

3. Open the rear door, release two bosses (callout 1), and then remove the cover (callout 2).

Figure 1-586 Remove the cover

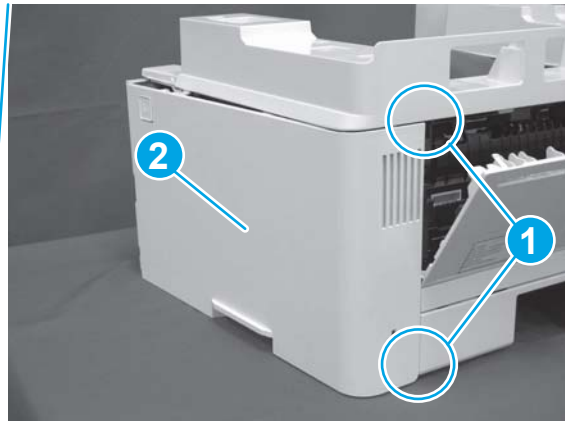
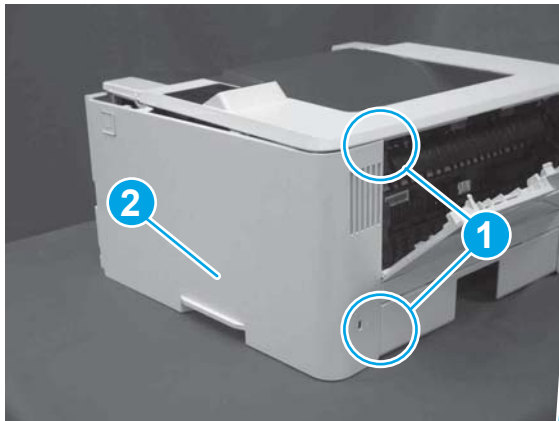

Step 5: Remove the rear door assembly

1. **Duplex models only:** Inside the Tray 2 cavity, press the green jam access lever (callout 1), and then lower the duplex feed assembly (callout 2).

Figure 1-587 Duplex models, lower the duplex feed assembly

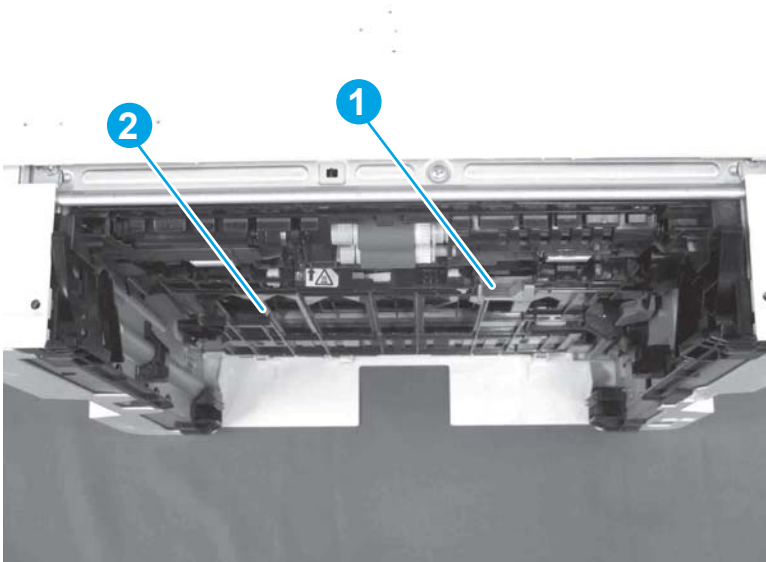

2. At the rear of the printer, remove two screws (callout 1), and then remove the rear door assembly (callout 2).

Figure 1-588 Remove two screws

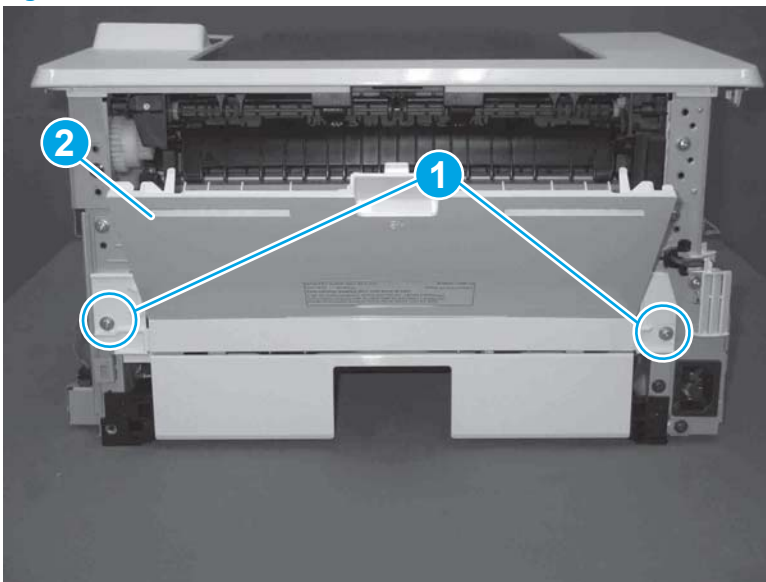

Step 6: Remove the fuser

1. Disconnect one connector (callout 1), and then release the wire harness from the guide (callout 2).

Figure 1-589 Disconnect one connector

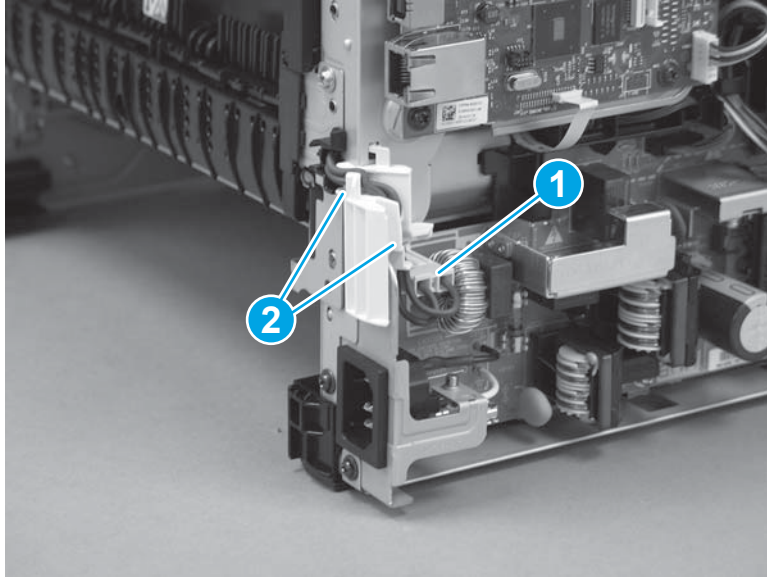

2. Pull the upper connector cover (callout 1) straight off of the printer to remove it.

Figure 1-590 Remove the cover

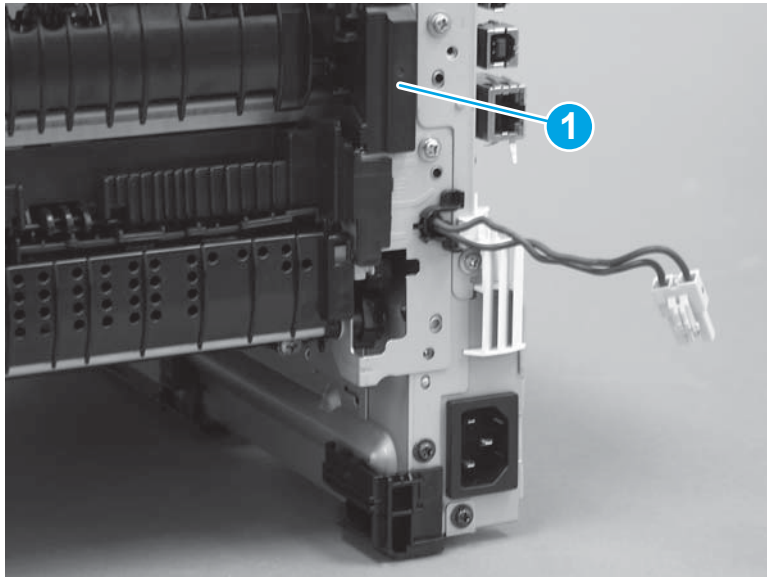

3. Disconnect two connectors (callout 1).

Figure 1-591 Disconnect two connectors

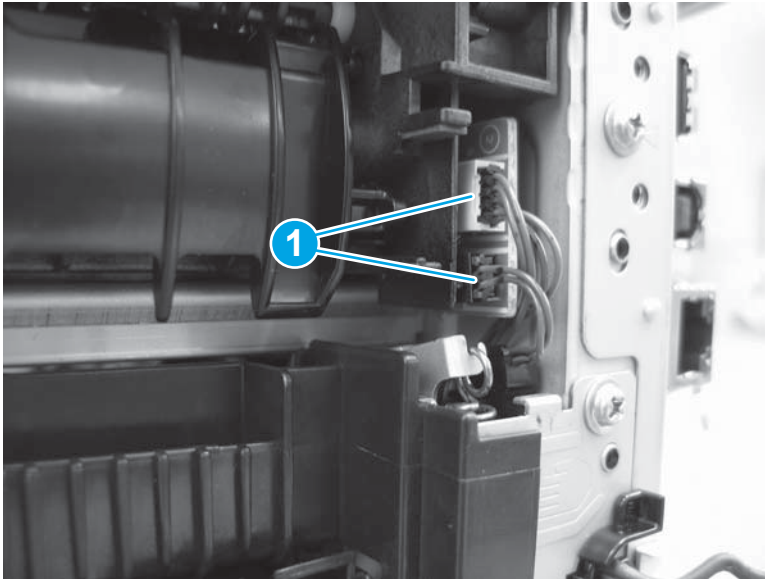

4. Remove four screws (callout 1).

Figure 1-592 Remove four screws

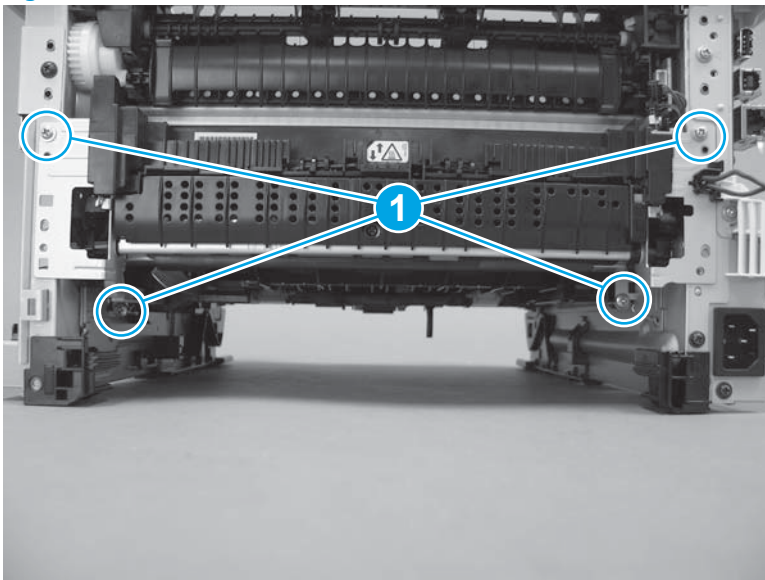

5. Pull the pressure-release link arm as shown to release it from the fuser.

Figure 1-593 Release the pressure-release arm

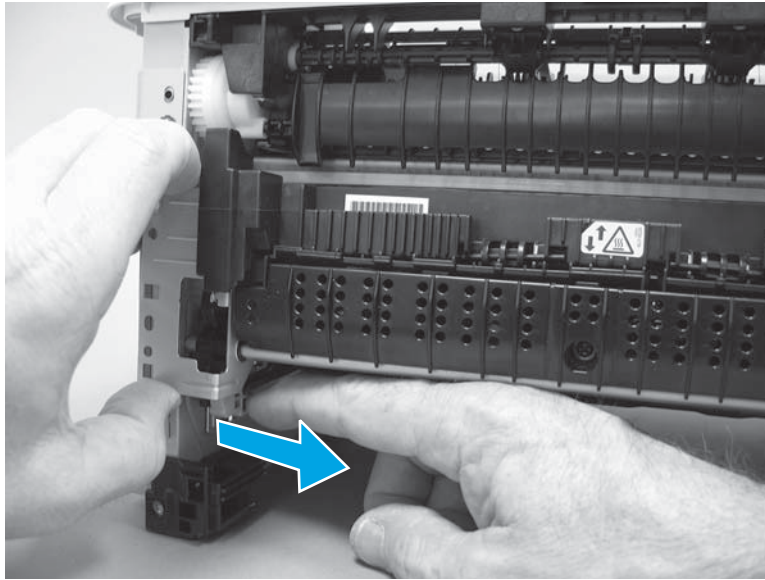

6. Slide the fuser straight out of the printer.

Figure 1-594 Remove the fuser

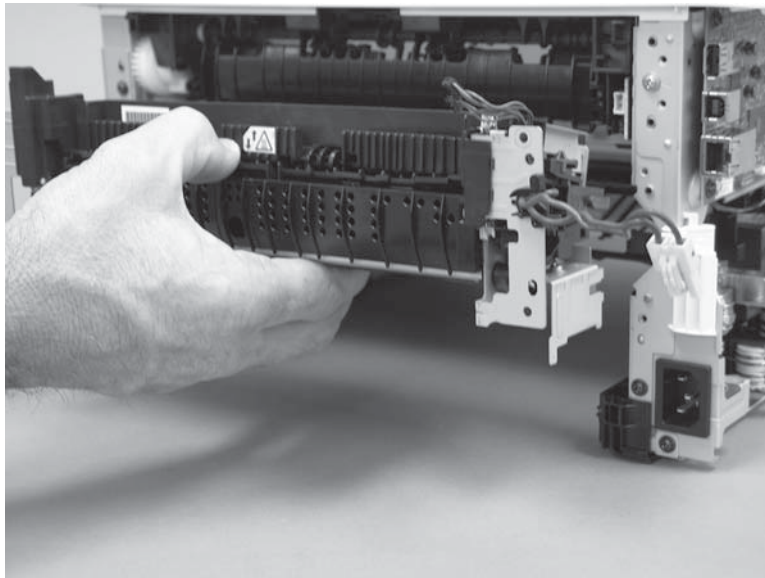

Step 7: Unpack the replacement assembly

Unpack the replacement part from the packaging.

<http://www8.hp.com/us/en/hp-information/environment/product-recycling.html>

 **NOTE:** HP recommends responsible disposal of the defective part.

Figure 1-595 Recycle and unpack

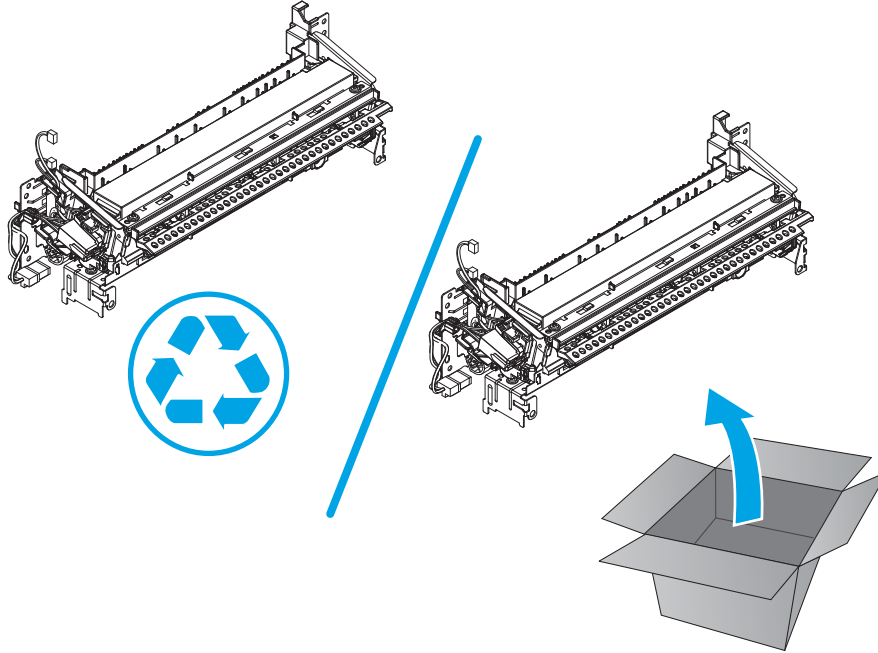

Step 8: Install the fuser

1. Slide the fuser straight into the printer.

Figure 1-596 Install the fuser

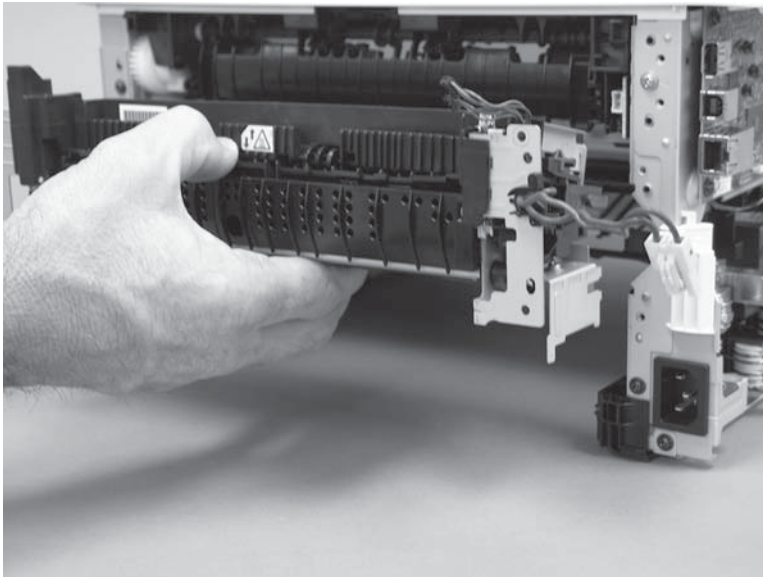

2. Connect the pressure-release link arm to the fuser.

 **IMPORTANT:** Make sure that the pressure-release arm is correctly connected to the fuser.

Figure 1-597 Connect the pressure-release arm

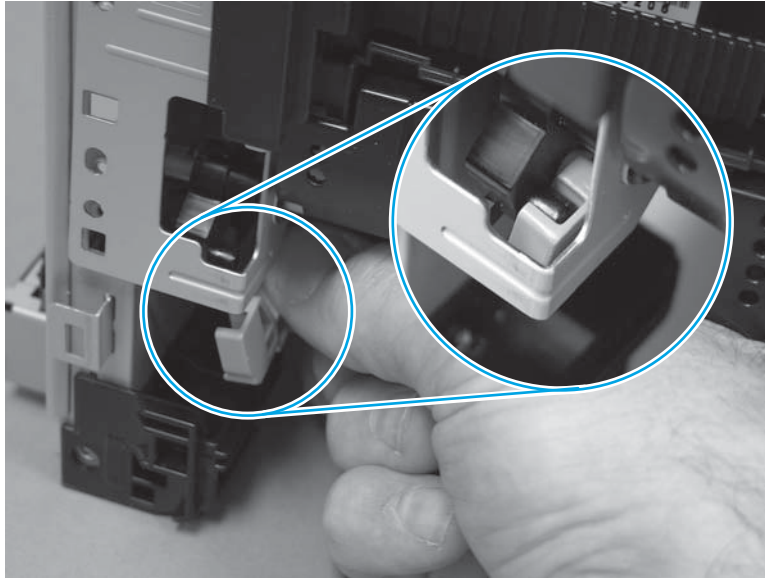

3. Install four screws (callout 1).

Figure 1-598 Install four screws

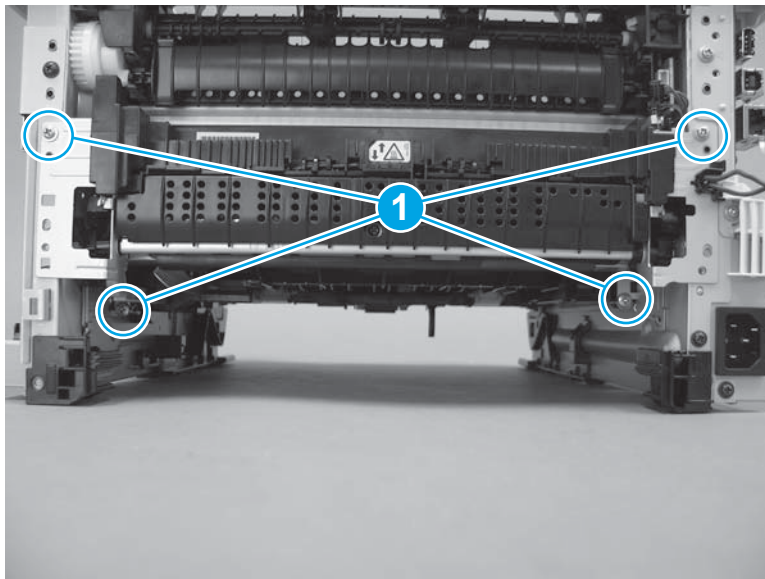

4. Connect two connectors (callout 1).

Figure 1-599 Connect two connectors

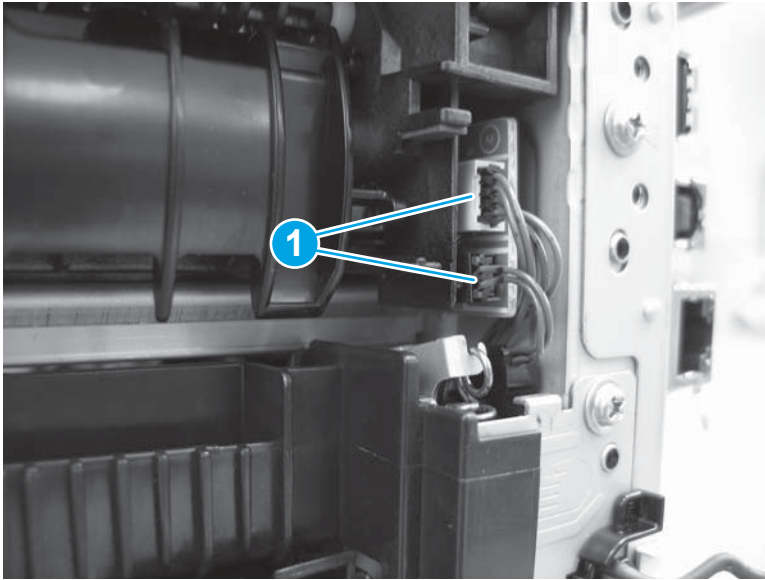

5. Push the upper connector cover (callout 1) straight onto of the printer to install it.

Figure 1-600 Install the cover

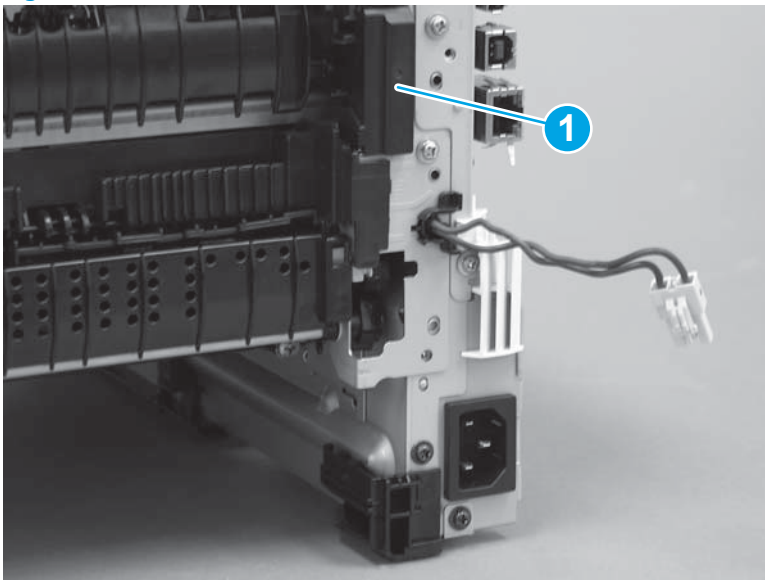

6. Install the wire harness in the guide (callout 1), and then connect one connector (callout 2).

Figure 1-601 Connect one connector

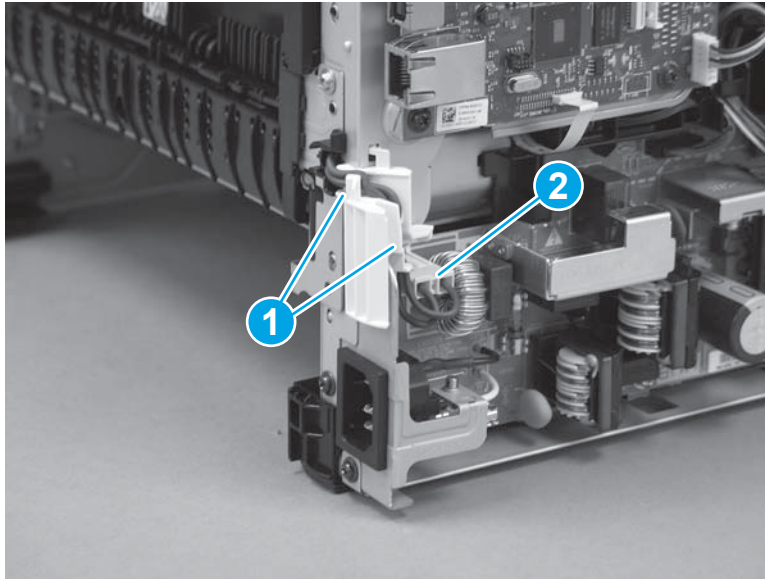

Step 9: Install the rear door assembly

1. At the rear of the printer, position the assembly so that the two tabs (callout 1) are installed in the slots (callout 2) in the chassis.



NOTE: Duplex models only: Slide the duplex tray into the Tray 2 cavity.

Figure 1-602 Install the rear cover

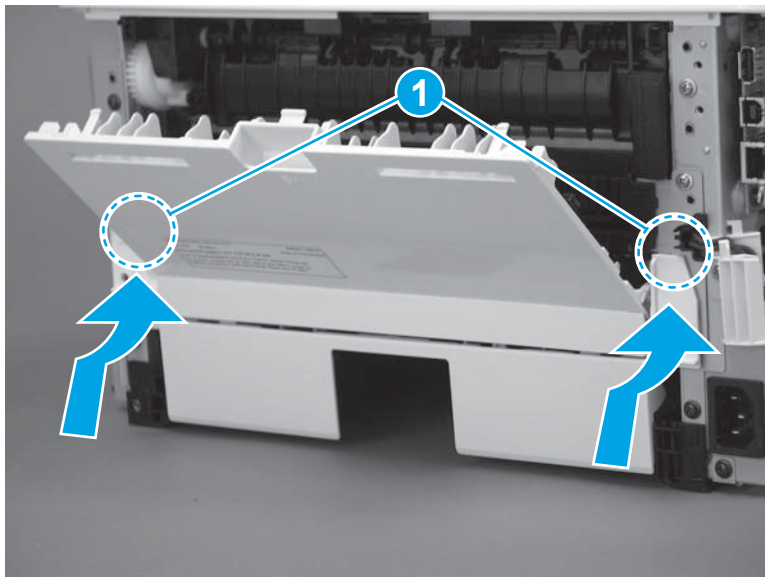

2. Install two screws.

 **NOTE: Duplex models only:** Reach in from the front of the Tray 2 cavity and raise the feed assembly to the up and locked position so that the rear cover will fit flat against the chassis.

Figure 1-603 Install two screws



Step 10: Install the right cover

1. Position the cover (callout 1) on the printer, and then engage two bosses (callout 2).

Figure 1-604 Install the cover

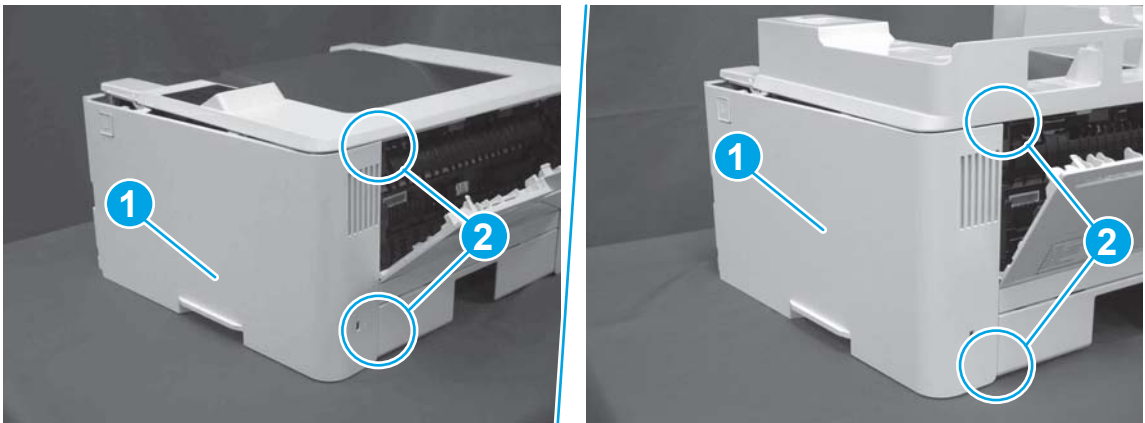

2. Rotate the front of the cover onto the printer (callout 1), engage three (callout 2) tabs, and then engage two bosses (callout 3).

Figure 1-605 Engage two bosses and one tab

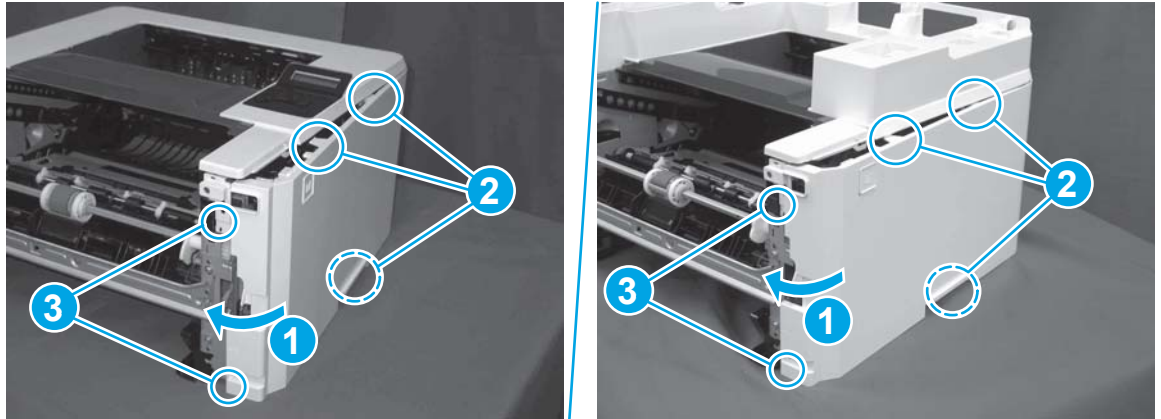

3. Make sure that the power switch (callout 1) and cartridge door assembly button (callout 2) correctly function.



NOTE: Remove, and then reinstall the cover if the switch or button does not correctly function.

Figure 1-606 Check the power switch and cartridge door assembly button

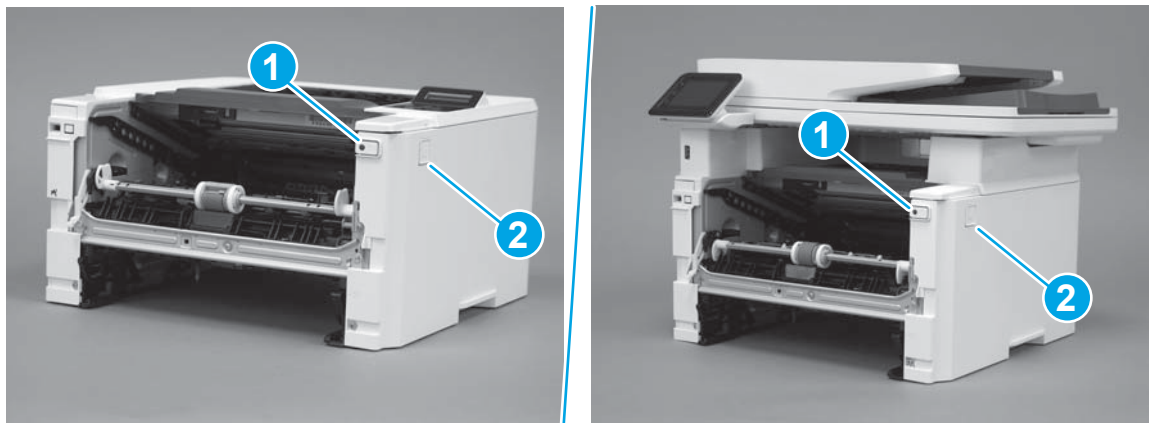

4. Install one screw (callout 1).

Figure 1-607 Install one screw



Step 11: Install the left cover

1. At the front of the printer, do one of the following:
 - **M403/M402:** Position the cover on the printer (callout 1), and then engage two bosses (callout 2).
 - **M427/M426:** Position the cover on the printer (callout 3), engage one tab (callout 4), and then engage two bosses (callout 4).

Figure 1-608 Install the cover

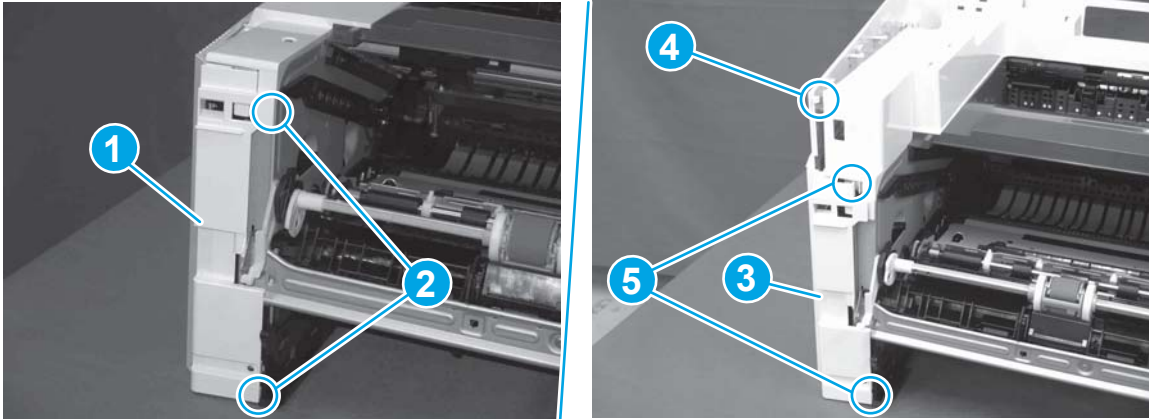

2. Carefully rotate the rear of the cover onto the printer (callout 1), engage three tabs (callout 2), and then engage two bosses (callout 3).

Figure 1-609 Engage three tabs and two bosses

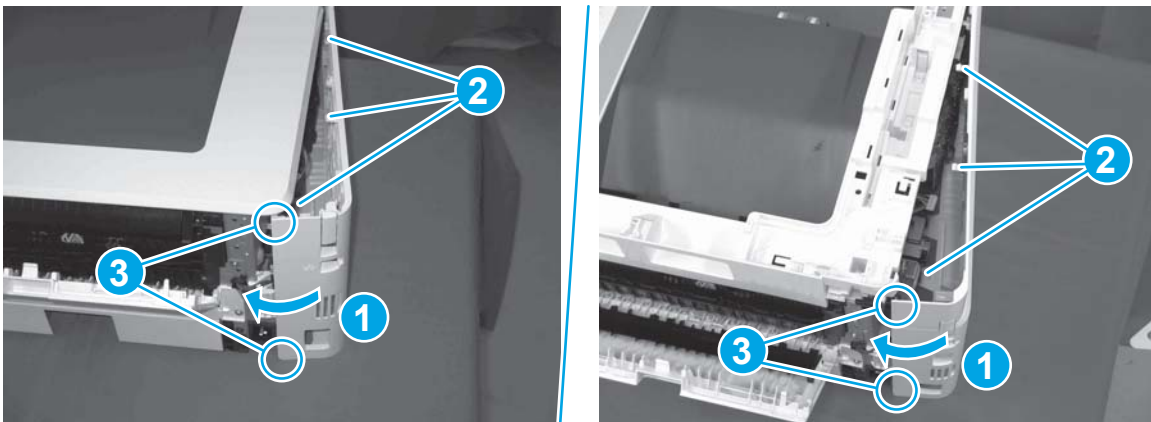

3. Install one screw (callout 1).

Figure 1-610 Install one screw

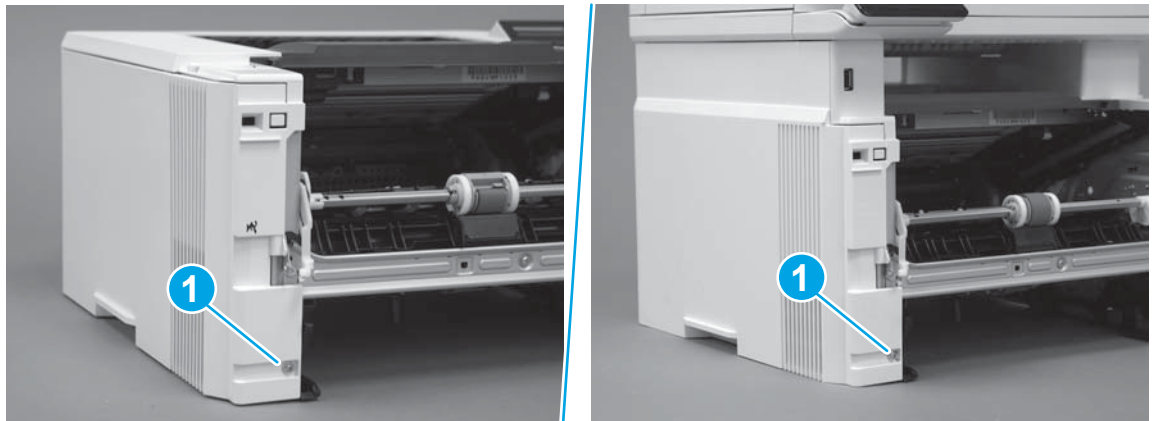

Step 12: Install the cartridge door assembly

 **Reinstallation tip:** After a replacement door is installed, make sure to install the nameplate (supplied in the kit) corresponding to the printer name on the door.

1. Position the door close to the printer, and then engage the keyed pin on the left-side retainer arm with the hole in the door.

Figure 1-611 Engage the left-side retainer arm

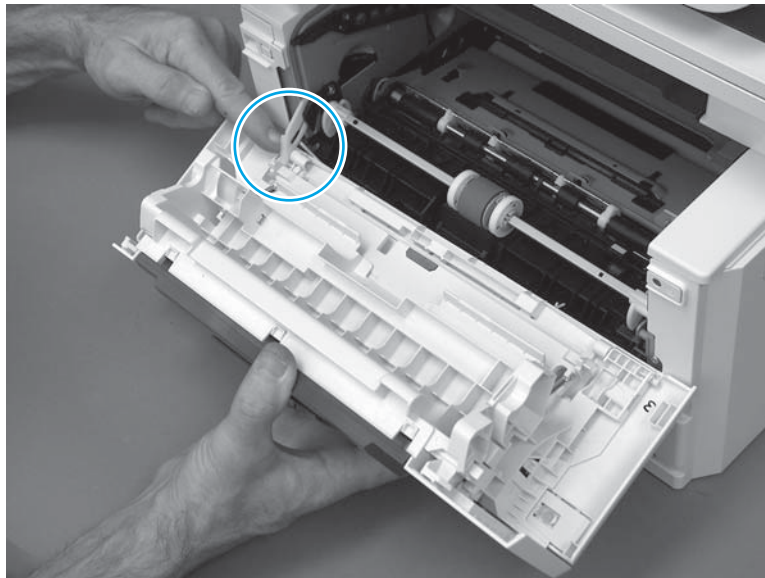

2. Engage the right-side door hinge pin with the hole in the chassis (callout 1).

Figure 1-612 Install the door

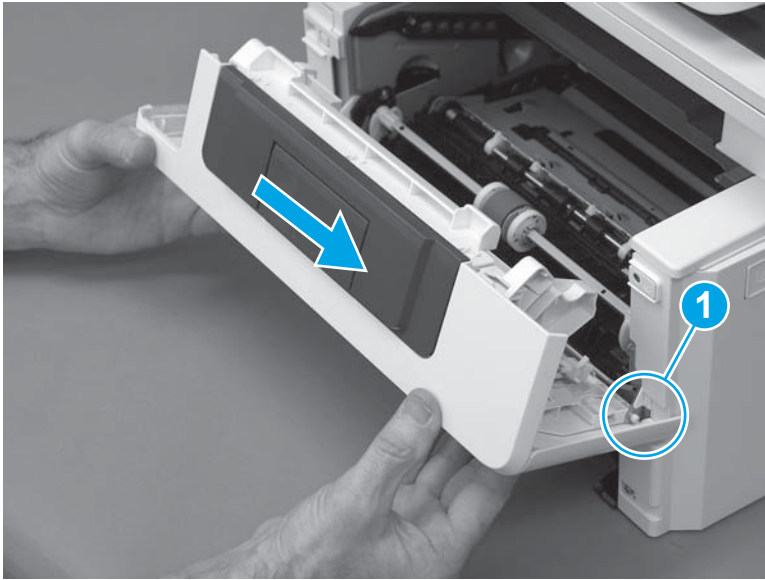

3. Install the link (callout 1).

 **IMPORTANT:** Make sure that the link snaps into place on the arm (callout 2). The link actuates the fuser pressure-release mechanism.

Figure 1-613 Install the pressure-release link

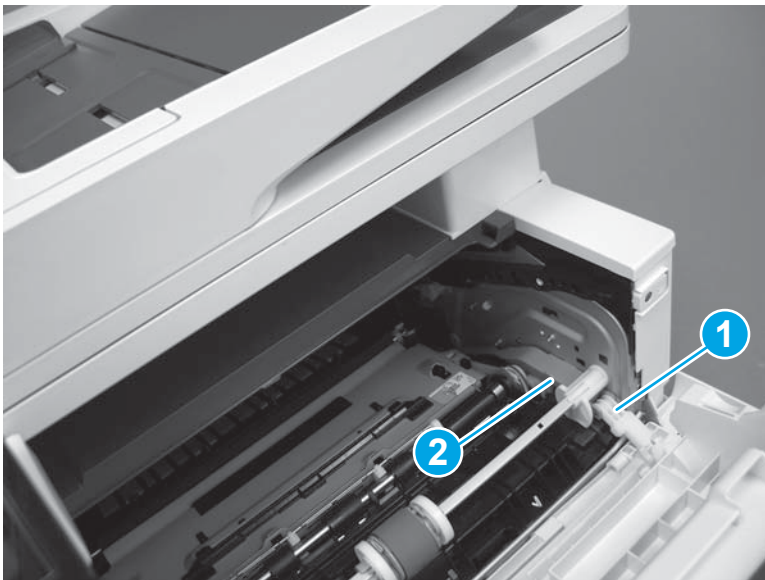

4. Slide the guide into the printer (callout 1), and then make sure that the tab (callout 2) snaps into place to secure the guide to the chassis.

Figure 1-614 Install the guide

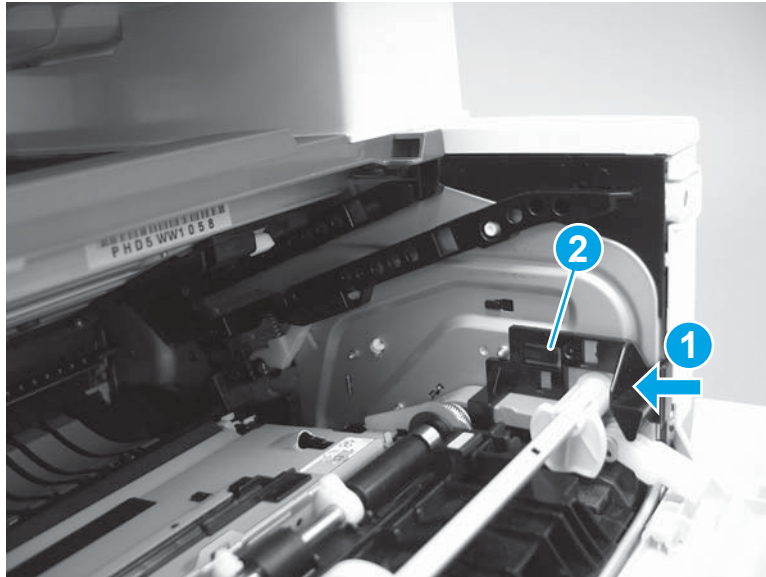

5. Position the shaft on the door, and then align the left-side hinge on the door with the hole in the chassis (callout 1).

Figure 1-615 Align the hinge

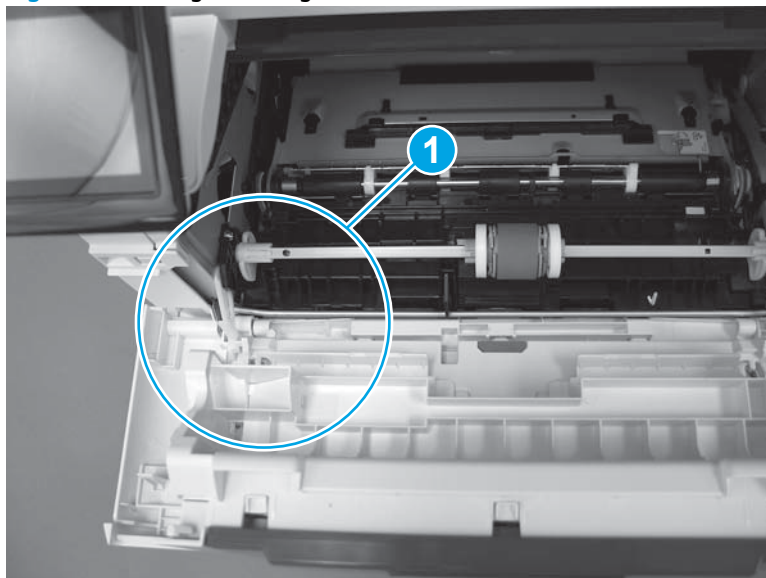

6. Push the shaft towards the left side of the printer to install it (callout 1).

 **Reinstallation tip:** Make sure that the support shaft is fully installed and correctly orientated (callout 2) so that it will not interfere with the door opening and closing.

Figure 1-616 Install the support shaft



Step 13: Install Tray 2

- ▲ Slide the tray straight into the printer to install it.

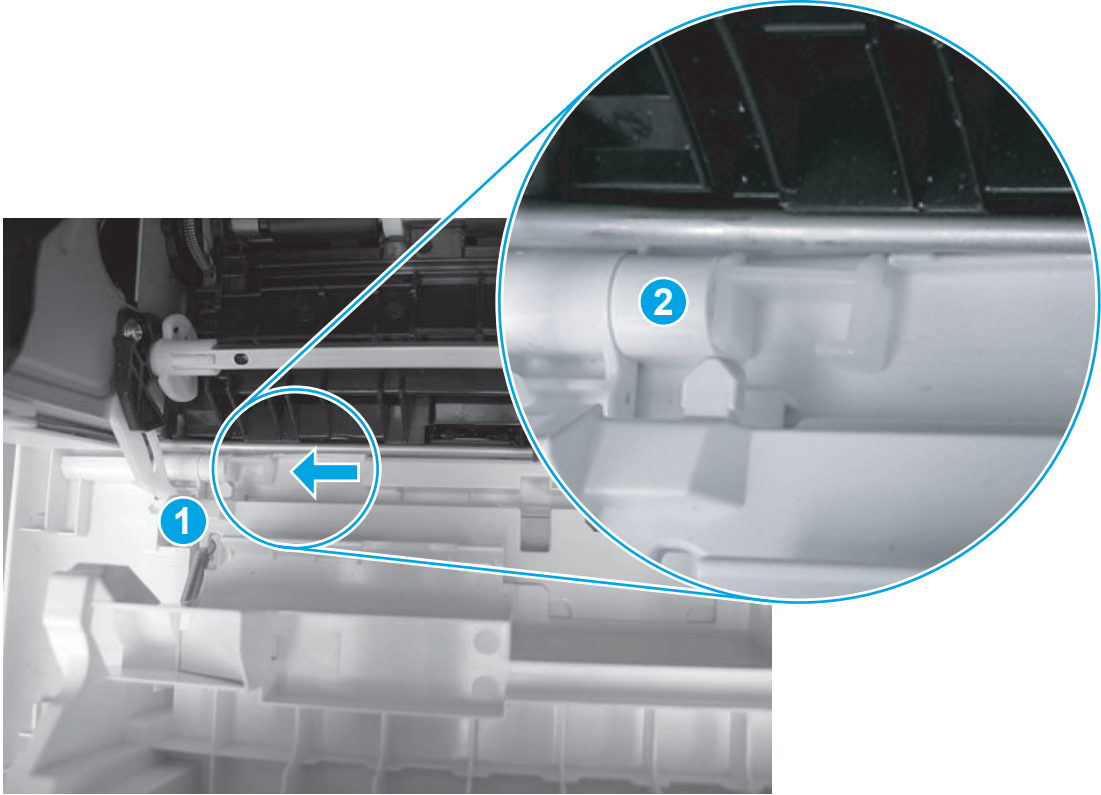
Figure 1-617 Install the tray



Removal and replacement: Registration assembly

- [Introduction](#)
- [Step 1: Remove Tray 2](#)
- [Step 2: Remove the cartridge door assembly](#)
- [Step 3: Remove the left cover](#)
- [Step 4: Remove the right cover](#)
- [Step 5: Remove the rear door assembly](#)
- [Step 6: Remove the integrated scanner assembly \(M427/M246\)](#)
- [Step 7: Remove the control panel \(M427/M426\)](#)
- [Step 8: Remove the top cover \(M427/M426\)](#)
- [Step 9: Remove the top cover \(M403/M402\)](#)
- [Step 10: Remove the paper delivery tray \(output bin\)](#)
- [Step 11: Remove the fuser](#)
- [Step 12: Remove the registration assembly](#)
- [Step 13: Unpack the replacement assembly](#)
- [Step 14: Install the registration assembly](#)
- [Step 15: Install the fuser](#)
- [Step 16: Install the paper delivery tray \(output bin\)](#)
- [Step 17: Install the top cover \(M403/M402\)](#)
- [Step 18: Install the top cover \(M427/M426\)](#)
- [Step 19: Install the control panel \(M427/M246\)](#)
- [Step 20: Install the integrated scanner assembly \(M427/M246\)](#)
- [Step 21: Install the rear door assembly](#)
- [Step 22: Install the right cover](#)
- [Step 23: Install the left cover](#)
- [Step 24: Install the cartridge door assembly](#)
- [Step 25: Install Install Tray 2](#)

Introduction

This document provides the procedures to remove and replace the registration assembly.

Before performing service

Turn the printer power off

- Disconnect the power cable.

 **WARNING!** To avoid damage to the printer, turn the printer off, wait 30 seconds, and then remove the power cable before attempting to service the printer.

Make sure the correct voltage fuser is installed in the printer.

 **CAUTION:** The fuser is hot. Wait at least 30 minutes after turning the printer off before removing the fuser.

Use the table below to identify the correct part number for your printer. To order the part, go to www.hp.com/buy/parts.

Registration assembly part number	
-----------------------------------	--

RM2-5671-000CN	Registration assembly
----------------	-----------------------

Required tools

- #2 Phillips screwdriver with a magnetic tip.

After performing service

Turn the printer power on

- Connect the power cable.
- Use the power switch to turn the power on.

Post service test

Make sure that the printer initializes to a **Ready** state.

Print a configuration page to make sure that the printer is functioning correctly.

Step 1: Remove Tray 2

- ▲ Pull the tray straight out of the printer to remove it.

Figure 1-618 Remove the tray



Step 2: Remove the cartridge door assembly

 **NOTE:** If the toner cartridge was not removed prior to servicing the printer, remove it now.

1. Release one tab (callout 1), and then slide shaft (callout 2) in the direction the arrow indicates and remove it.

 **TIP:** It might be easier to release the support shaft by using a small flat-blade screwdriver.

Figure 1-619 Release the support shaft

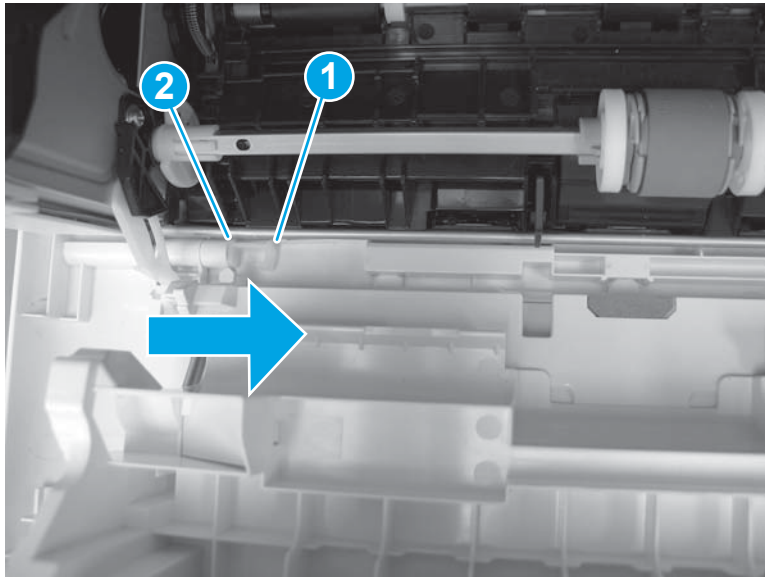

2. Release one tab (callout 1), and then slide the guide (callout 2) in the direction the arrow indicates and remove it.

Figure 1-620 Remove the guide

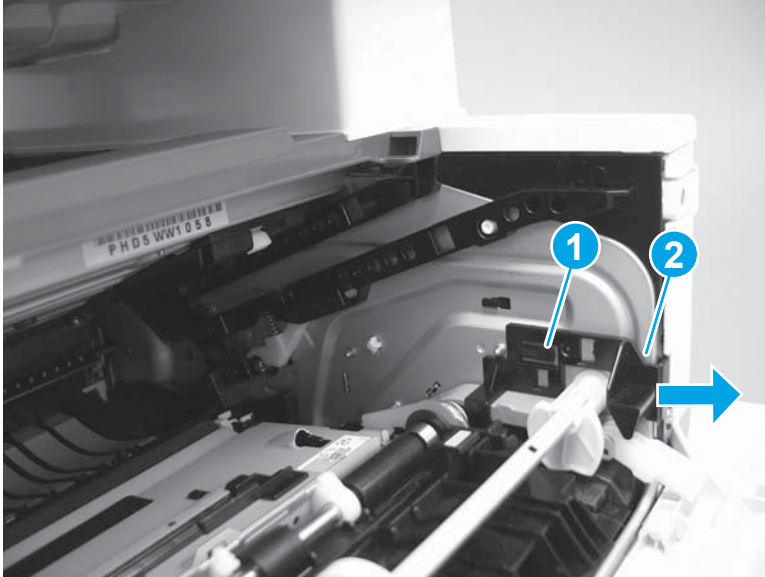

3. Remove the link arm (callout 1).

Figure 1-621 Remove the link arm

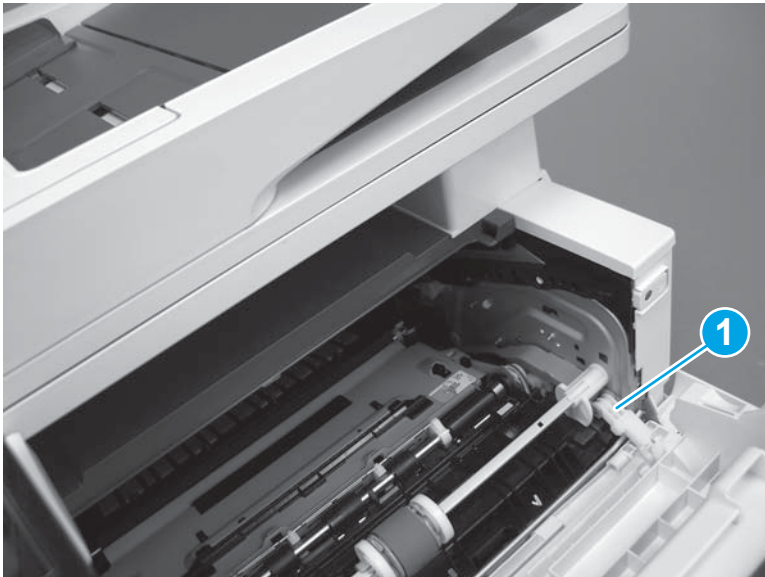

4. Slide the cartridge door assembly (callout 1) in the direction the arrow indicates and remove it.

Figure 1-622 Remove the door

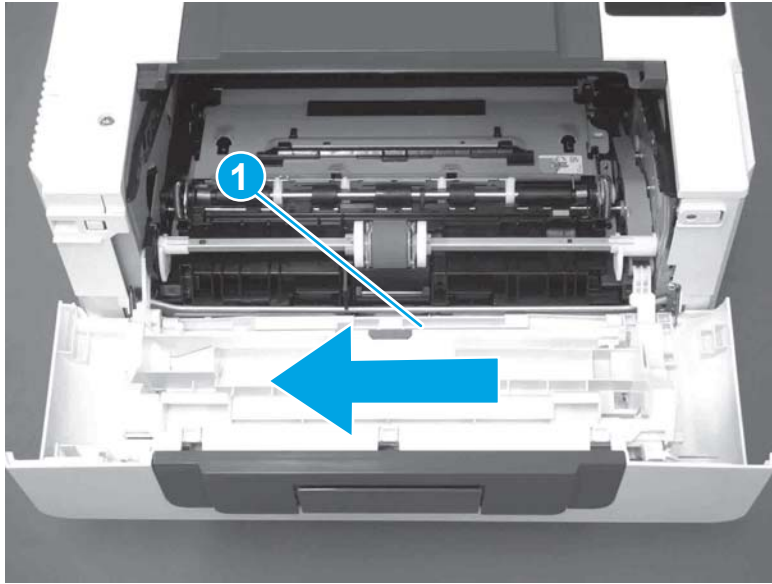

5. Remove the link (callout 1) from the cartridge door assembly (callout 2).

Figure 1-623 Release the left-side retainer arm

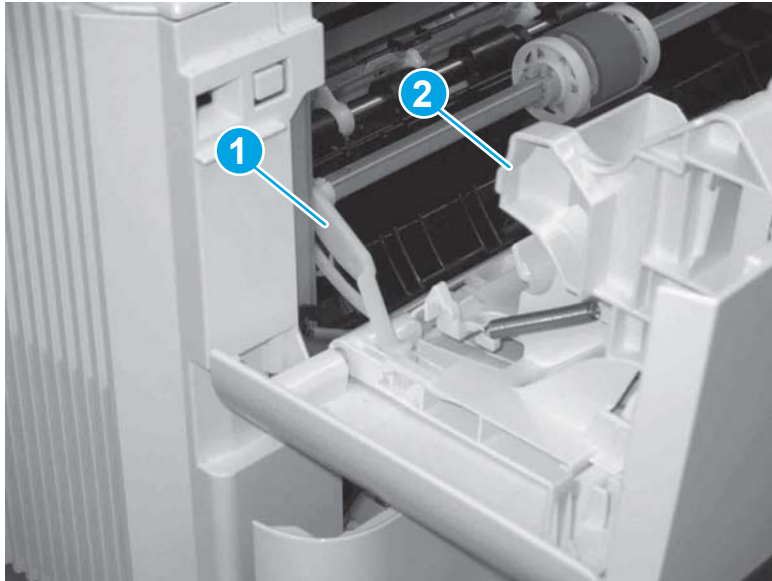

Step 3: Remove the left cover

1. Remove one screw (callout 1).

Figure 1-624 Remove one screw

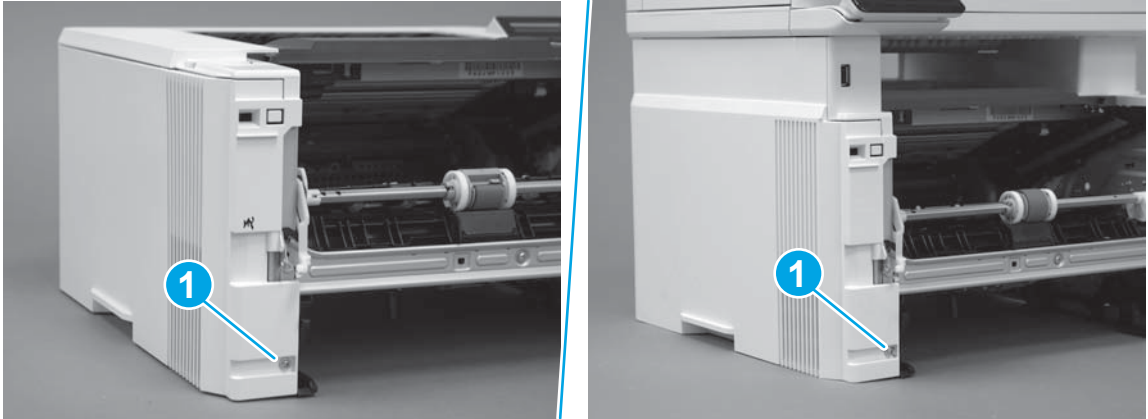

2. Open the rear door, release two bosses (callout 1), and then release three tabs (callout 2).

Figure 1-625 Release two bosses and three tabs

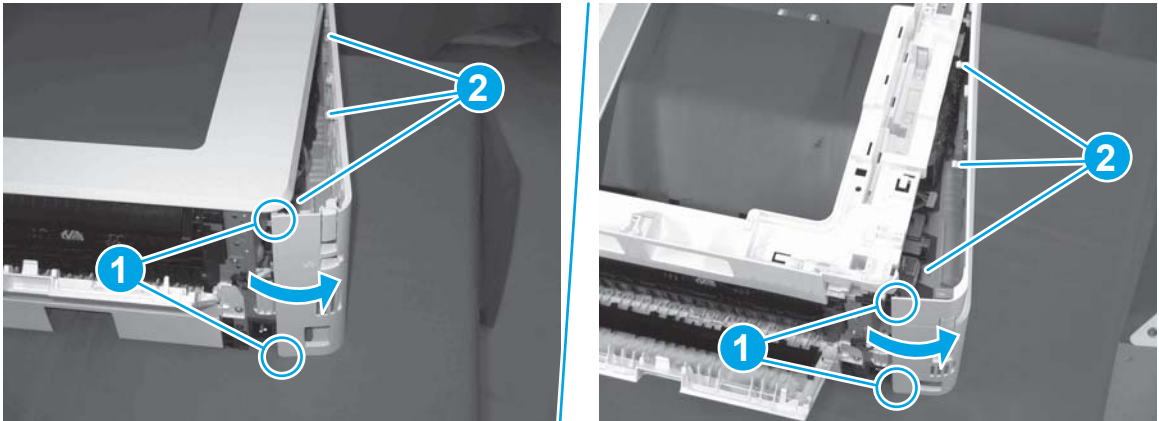

3. At the front of the printer, do one of the following:
 - **M403/M402:** Release two bosses (callout 1), and then remove the cover (callout 2).
 - **M427/M426:** Release one tab (callout 3), two bosses (callout 4), and then remove the cover (callout 5).

CAUTION: Be careful when releasing the upper bosses on the M427/M426 cover. One portion of the cover (callout 6) is fragile and is easily broken.

Figure 1-626 Remove the cover

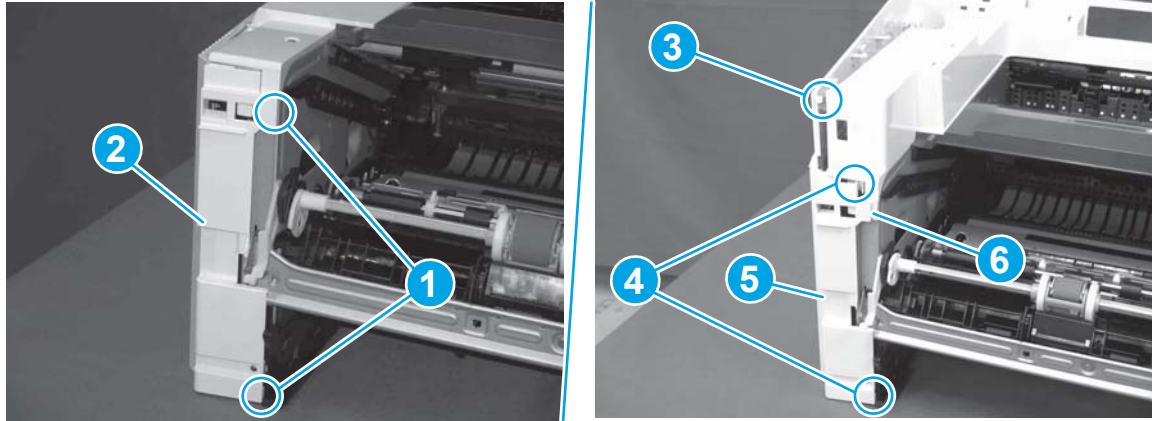

Step 4: Remove the right cover

1. Remove one screw (callout 1).

Figure 1-627 Remove one screw



2. At the front of the printer, release two bosses (callout 1), and then release three tabs (callout 2).

Figure 1-628 Release two bosses and three tabs

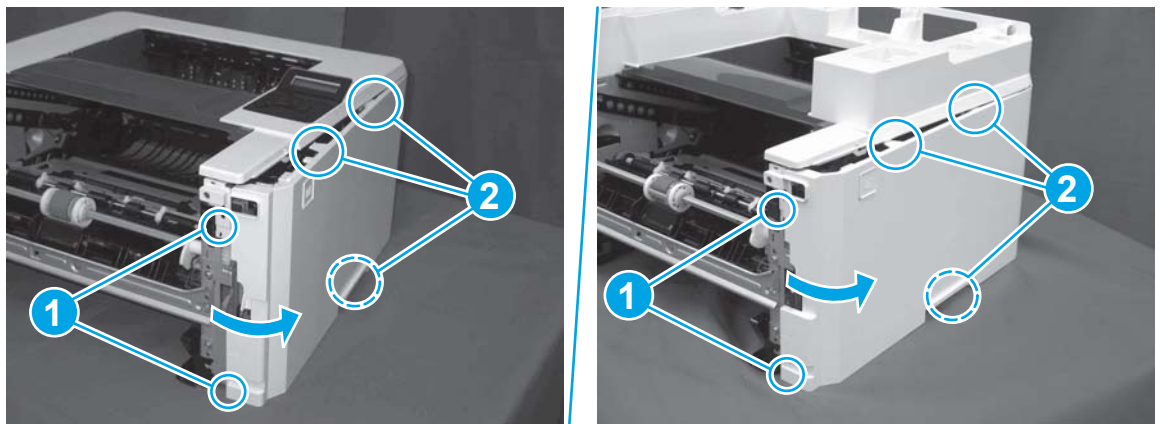

3. Open the rear door, release two bosses (callout 1), and then remove the cover (callout 2).

Figure 1-629 Remove the cover

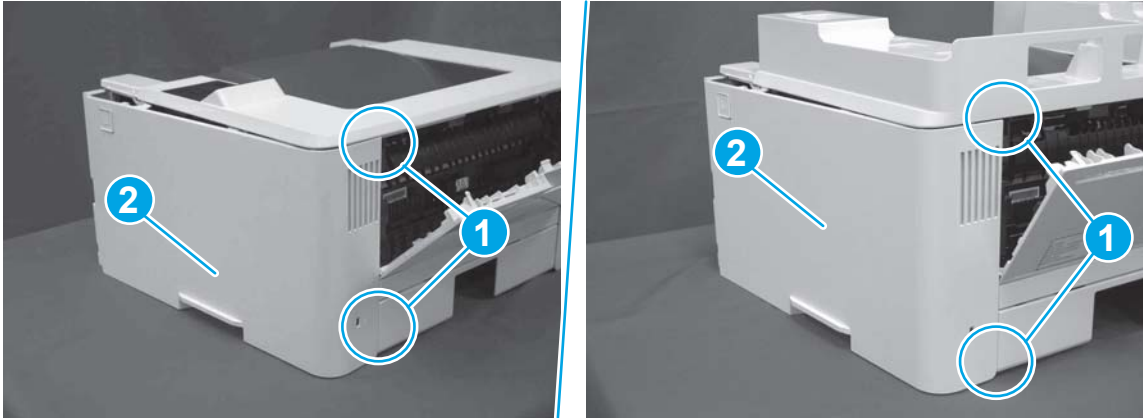

Step 5: Remove the rear door assembly

1. **Duplex models only:** Inside the Tray 2 cavity, press the green jam access lever (callout 1), and then lower the duplex feed assembly (callout 2).

Figure 1-630 Duplex models, lower the duplex feed assembly

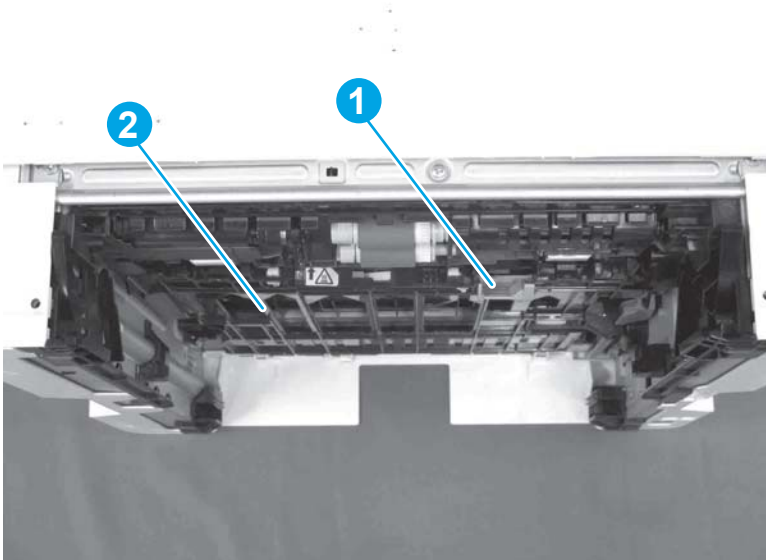

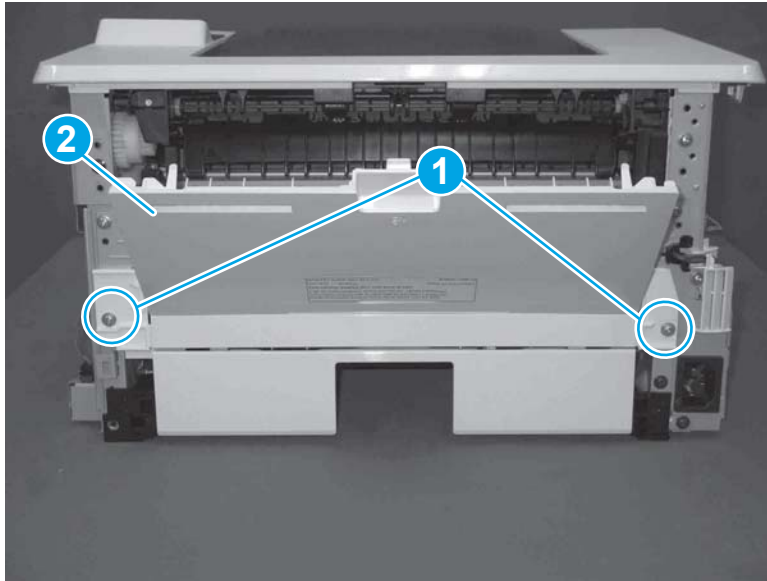

2. At the rear of the printer, remove two screws (callout 1), and then remove the rear door assembly (callout 2).

Figure 1-631 Remove two screws



Step 6: Remove the integrated scanner assembly (M427/M246)

 **NOTE:** The step is for the M427/M426 printer. For the M403/M402, skip this step and go to [Step 9: Remove the top cover \(M403/M402\) on page 365](#).

 **NOTE:** M427/M426 models only. The integrated scanner assembly (ISA) includes the sub-scanner assembly (SSA) and the automatic document feeder (ADF).

1. Raise the ISA.

Figure 1-632 Raise the ISA

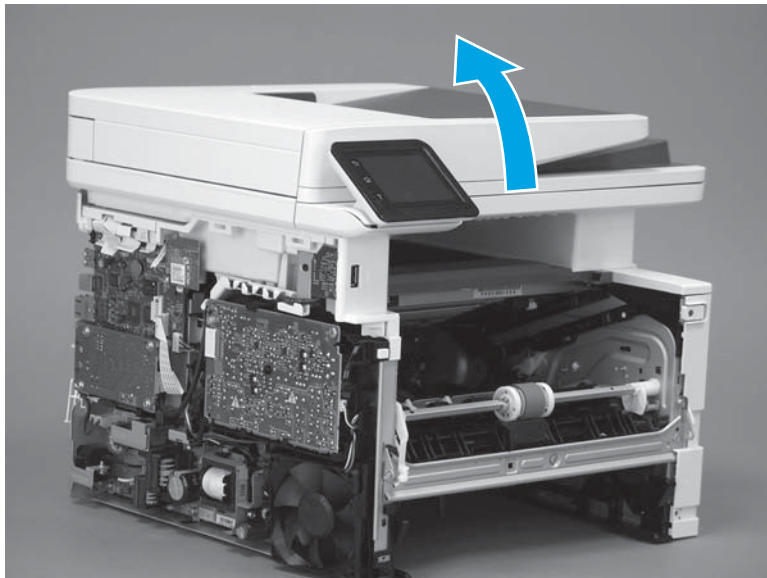

2. Release the ISA flat-flexible cable (FFC) cover (callout 1), and then remove it (callout 2).

Figure 1-633 Remove the ISA FFC cover

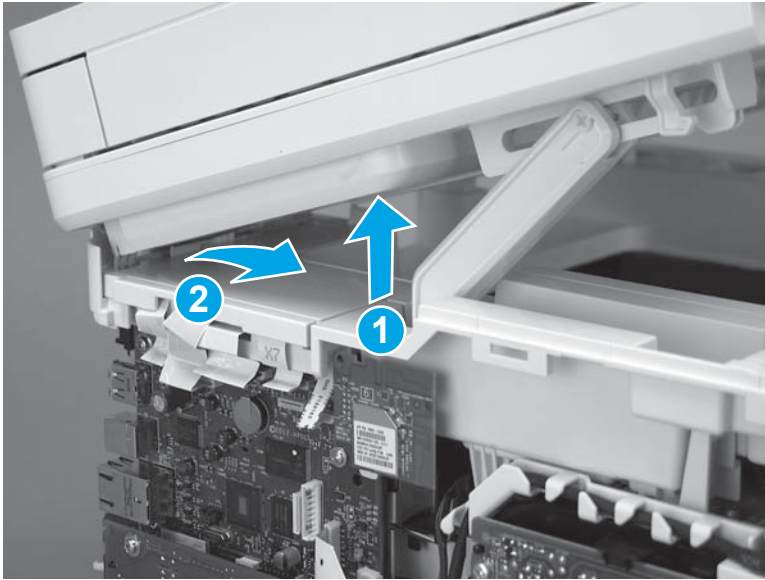

3. Disconnect three FFCs (callout 1), and then remove the ferrite (callout 2) from the holder.

CAUTION: The ferrite is not captive on the FFC. Do not lose the ferrite while handling the ISA.

Figure 1-634 Disconnect three FFCs

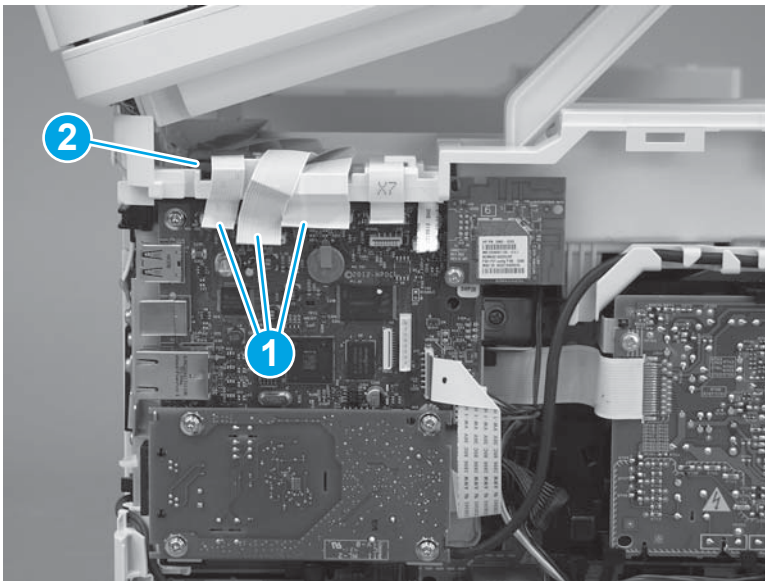

4. Remove one screw (callout 1).

Figure 1-635 Remove one screw

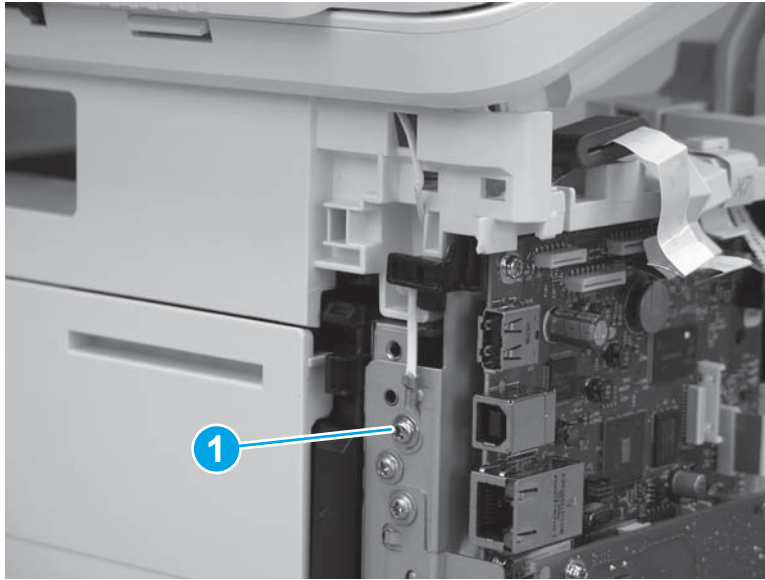

5. Pass the ground wire through the opening in the top cover.

Figure 1-636 Pass the wire through the opening

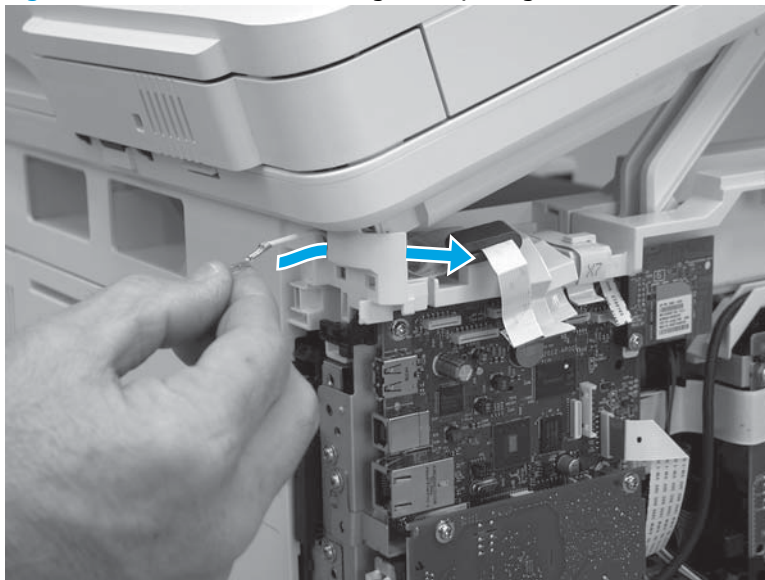

6. Release one tab (callout 1), and then rotate the ISA slider pin (callout 2) towards the front of the printer to release it.

Figure 1-637 Release one tab and rotate the slider pin

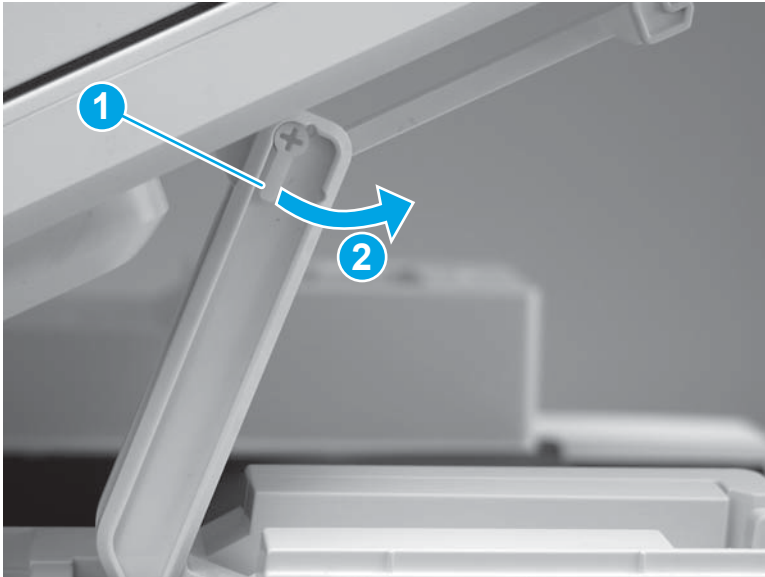

7. Remove the slider pin.

Figure 1-638 Remove the slider pin

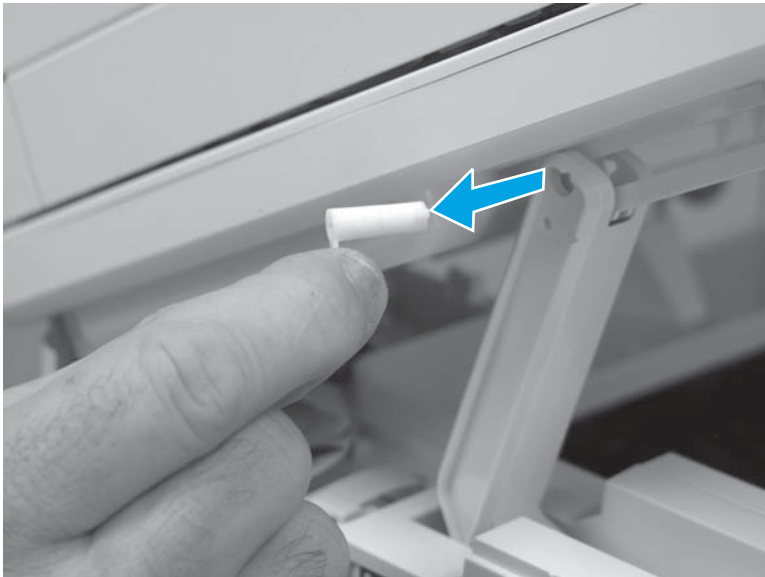

8. Rotate the ISA towards the rear of the printer until it stops.

Figure 1-639 Rotate the ISA towards the rear of the printer

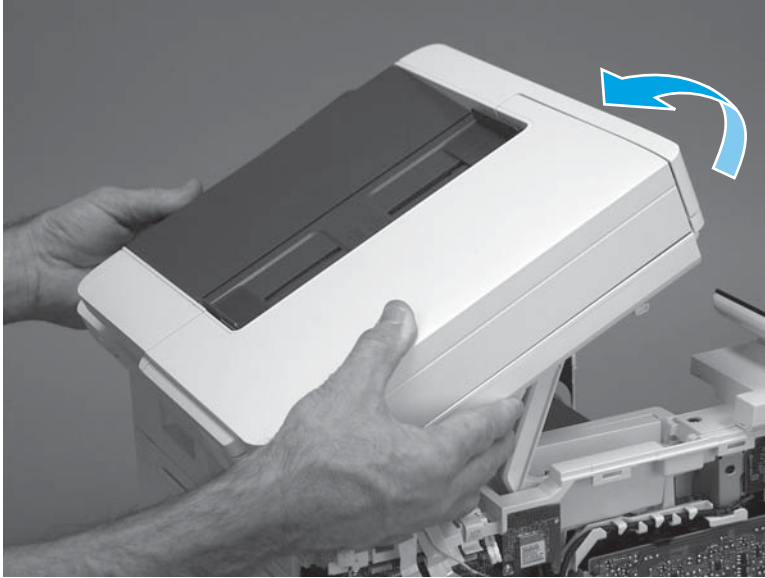

9. Slide the ISA as shown to release it.

Figure 1-640 Release the ISA

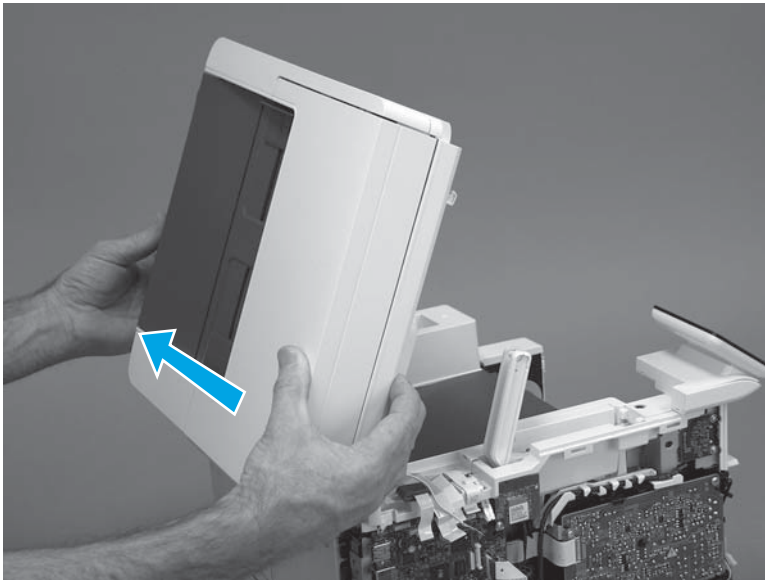

10. Remove the ISA.

Figure 1-641 Remove the ISA

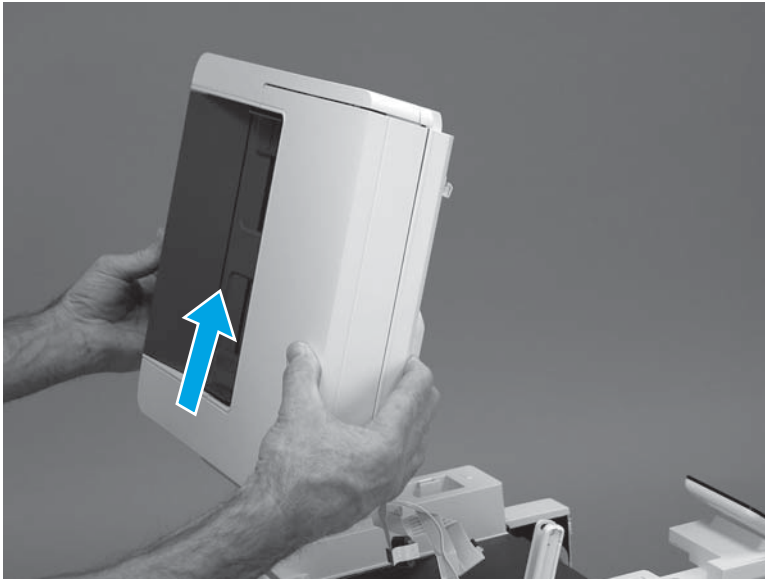

Step 7: Remove the control panel (M427/M426)



NOTE: The step is for the M427/M426 printer. For the M403/M402, skip this step and go to [Step 9: Remove the top cover \(M403/M402\)](#) on page 365.

1. Disconnect one FFC (callout 1; J114), and then release the FFC from the retainer (callout 2).

Figure 1-642 Disconnect one connector

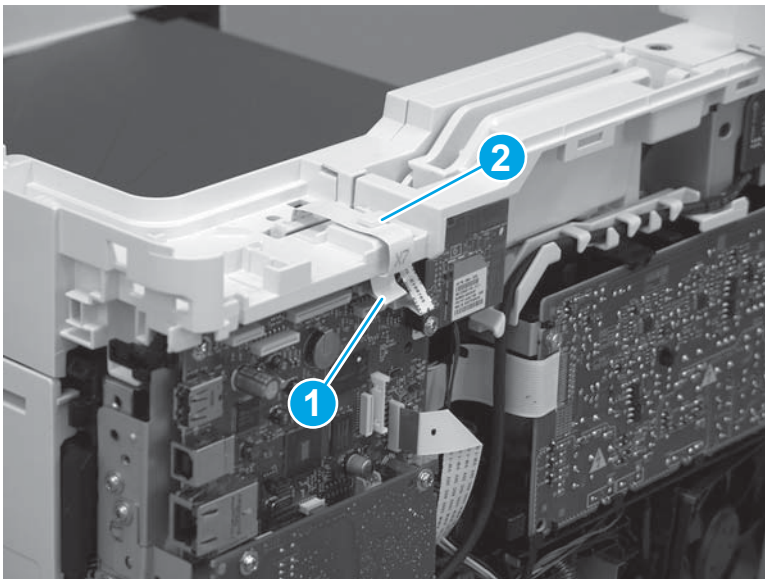

2. Remove one screw (callout 1).

Figure 1-643 Remove one screw

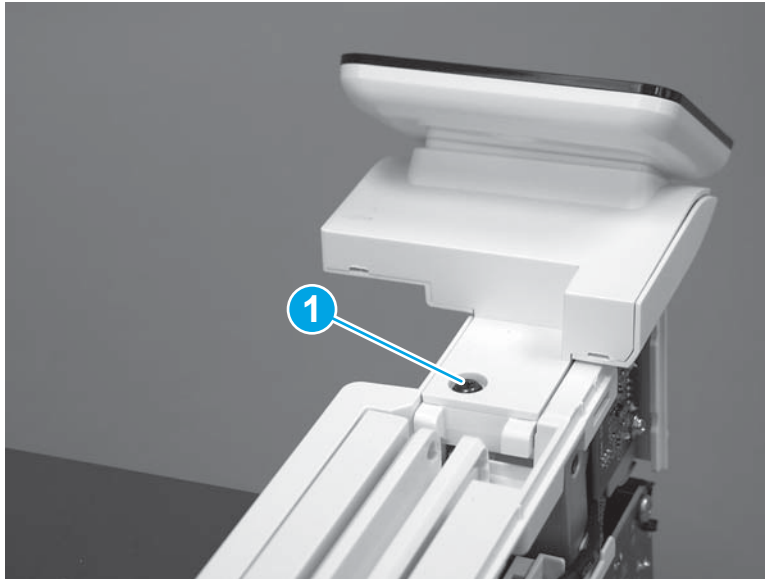

3. Use a small flat-blade screwdriver to release two tabs (callout 1) on the control-panel cable cover.

Figure 1-644 Release two tabs

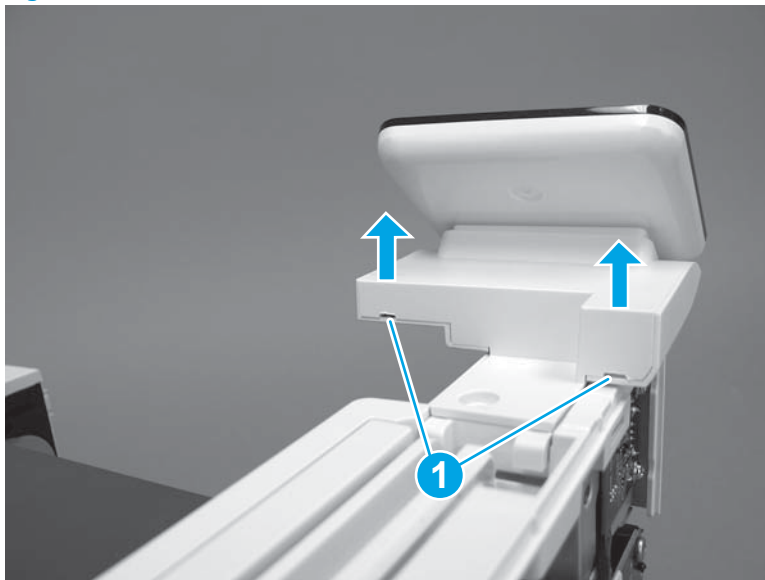

4. Remove the control-panel cable cover.

Figure 1-645 Remove the cover

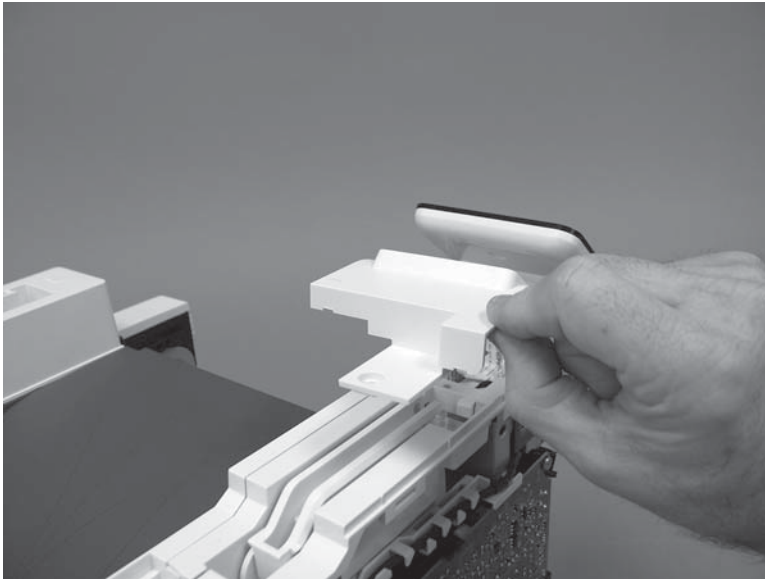

5. Remove one grounding screw (callout 1), and then move the ground cable (callout 2) out of the way.

Figure 1-646 Remove one screw

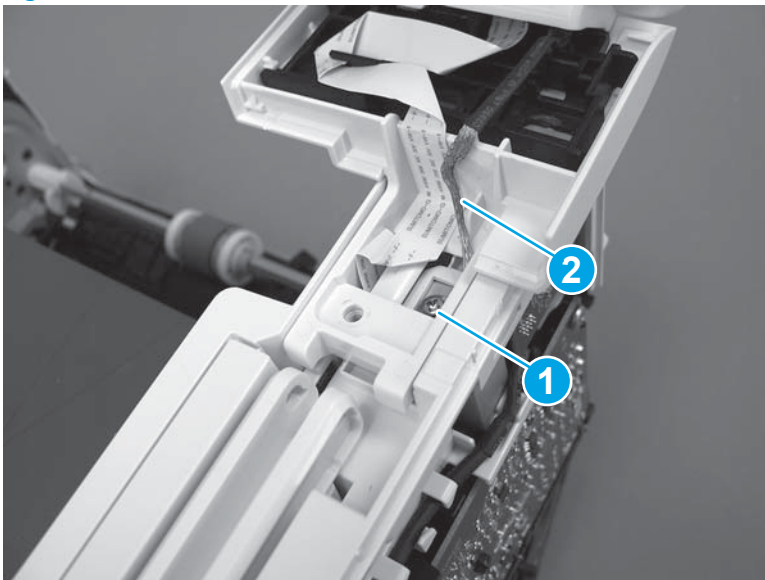

6. Move the FFC out of the way, and then remove two screws (callout 1).

Figure 1-647 Remove two screws

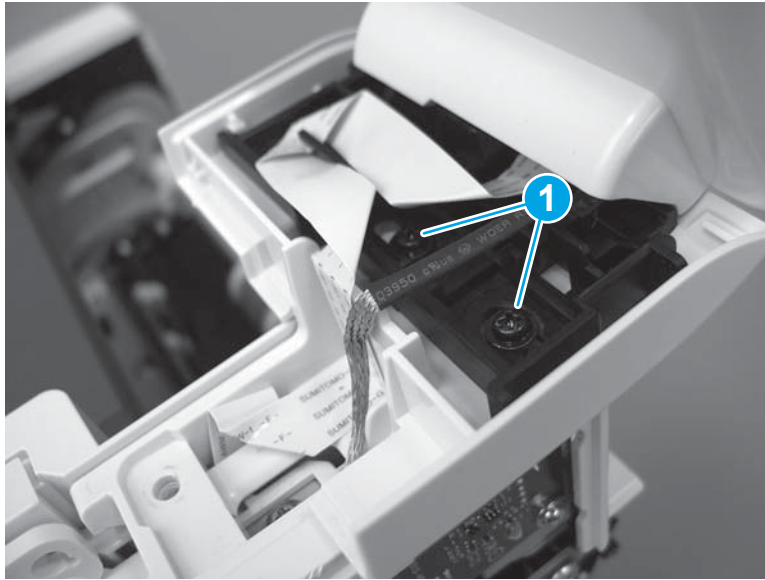

7. Slightly lift up the control-panel assembly to separate it from the top cover.

⚠ CAUTION: The control panel assembly is still connected to the printer by the FFC. Do not attempt to completely remove the assembly.

Figure 1-648 Lift up the control-panel assembly

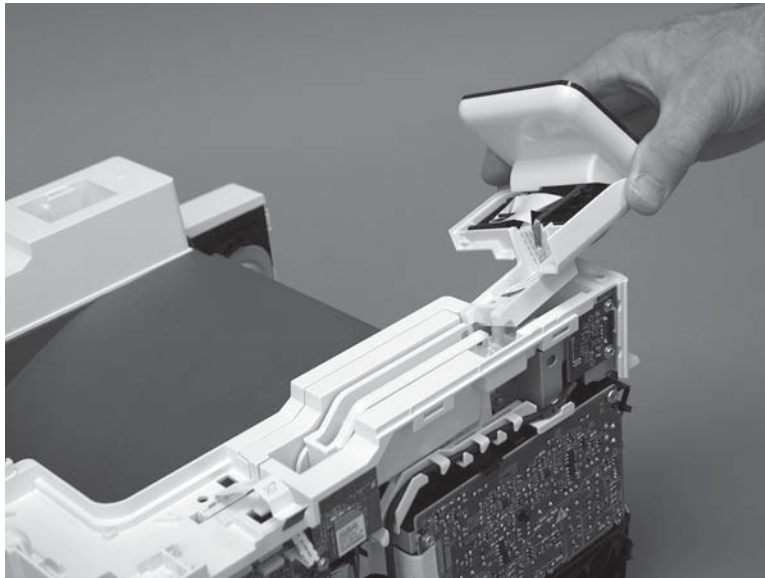

8. Lift up the control-panel FFC cover to remove the control-panel assembly.

Figure 1-649 Remove the control-panel assembly

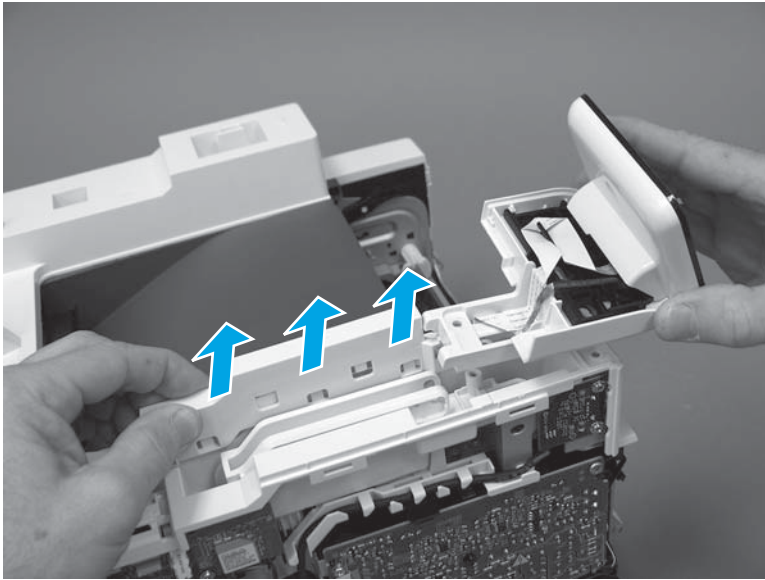

Step 8: Remove the top cover (M427/M426)



NOTE: The step is for the M427/M426 printer. For the M403/M402, skip this step and go to [Step 9: Remove the top cover \(M403/M402\) on page 365](#).

1. Release the USB cable (callout 1) from the cable guide.

Figure 1-650 Remove the USB cable

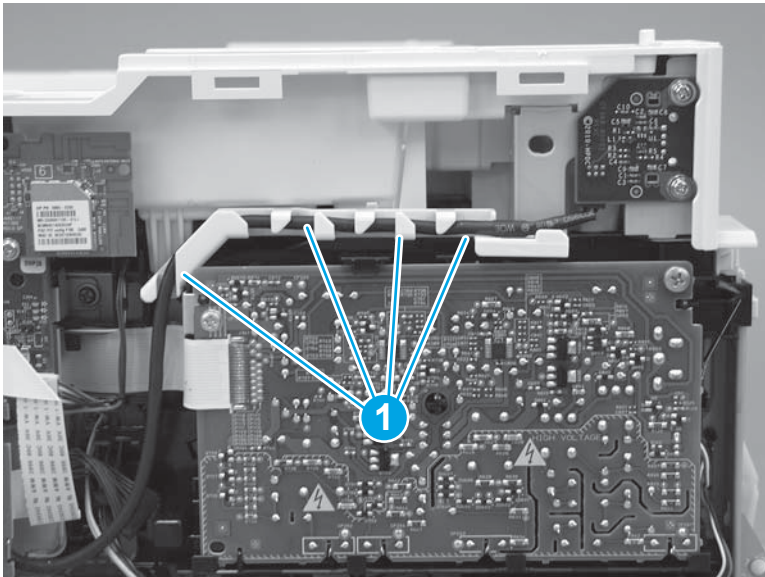

2. Remove five screws (callout 1), release four bosses (callout 2), and then remove the top cover (callout 3).

Figure 1-651 Remove the cover

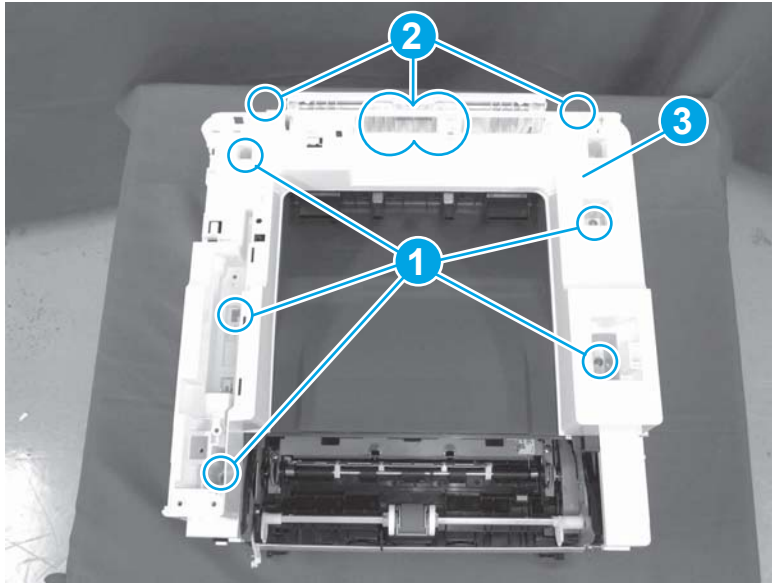

Step 9: Remove the top cover (M403/M402)

 **NOTE:** The step is for the M403/M402 printer. For the M427/M426, skip this step and go to [Step 10: Remove the paper delivery tray \(output bin\) on page 366](#).

1. Remove one screw (callout 1).

Figure 1-652 Remove one screw



2. At the right side of the printer, release the one boss (callout 1), and then release one tab (callout 2).

Figure 1-653 Release one boss and one tab

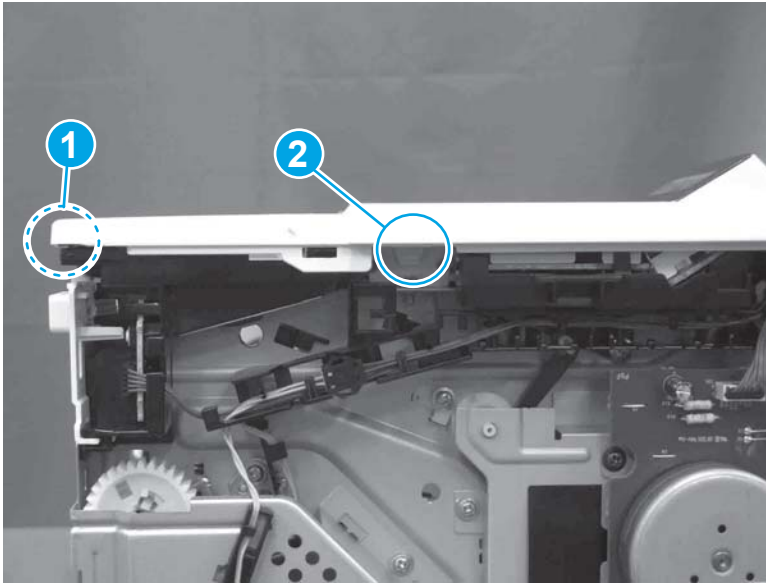

3. Release four tabs (callout 1), release four bosses (callout 2), and then remove the top cover (callout 3).



 **TIP:** Open the rear door to make releasing the bosses (callout 3) easier.

Figure 1-654 Remove the cover

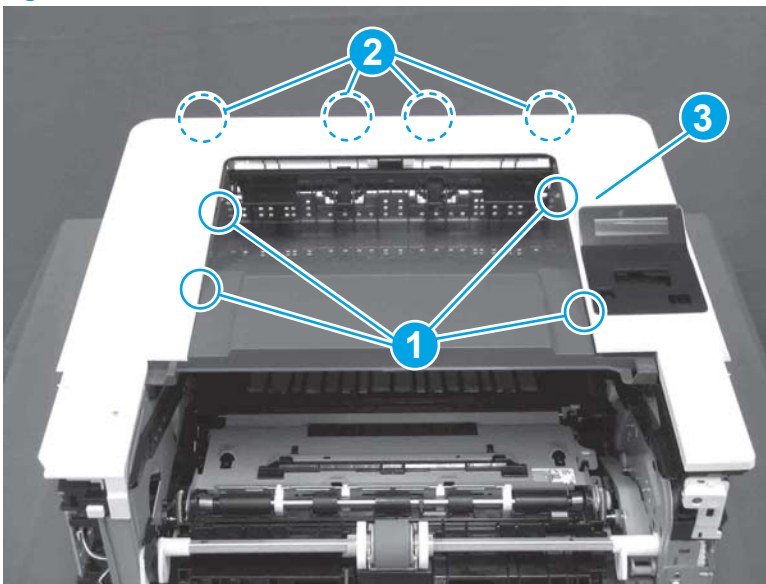

Step 10: Remove the paper delivery tray (output bin)

 **NOTE:** This procedure shows the M403/M402 model, however, the paper delivery tray (output bin) removal is similar for the M427/M426 printer.

- ▲ Release two bosses (callout 1), release two tabs (callout 2), and then remove the paper delivery tray (output bin; callout 3).

Figure 1-655 Release two tabs

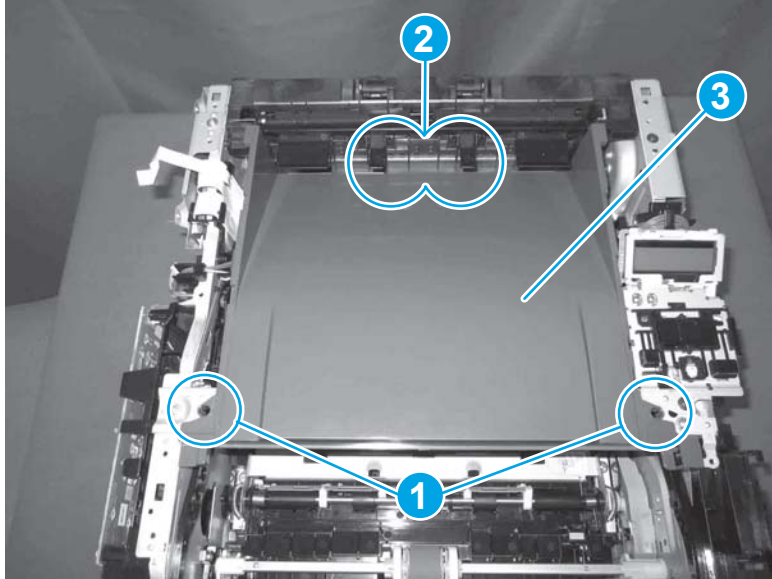

Step 11: Remove the fuser

1. Disconnect one connector (callout 1), and then release the wire harness from the guide (callout 2).

Figure 1-656 Disconnect one connector

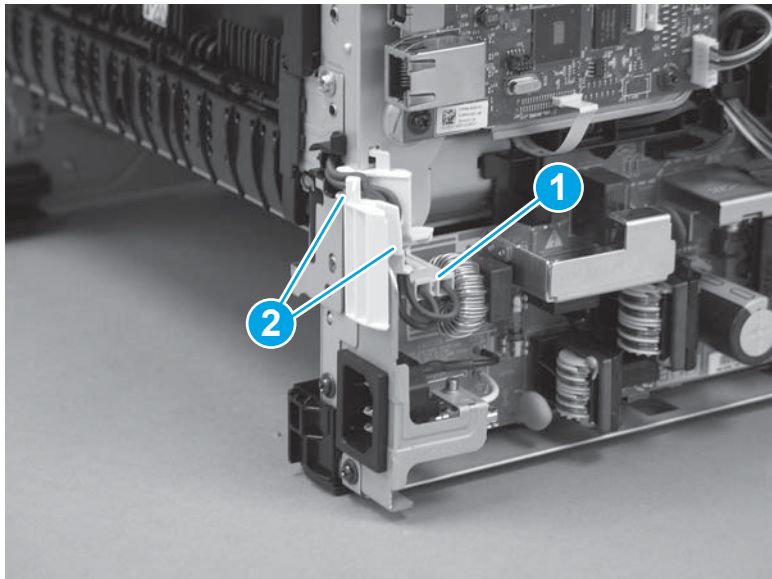

2. Pull the upper connector cover (callout 1) straight off of the printer to remove it.

Figure 1-657 Remove the cover

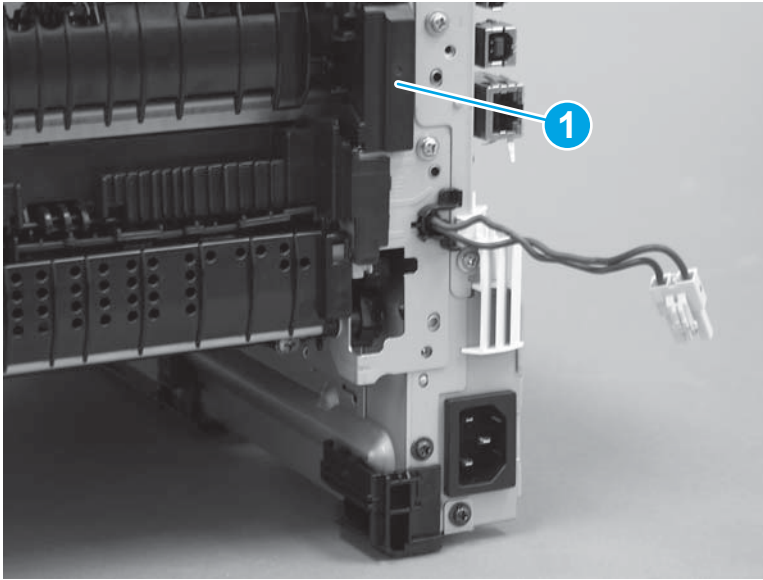

3. Disconnect two connectors (callout 1).

Figure 1-658 Disconnect two connectors

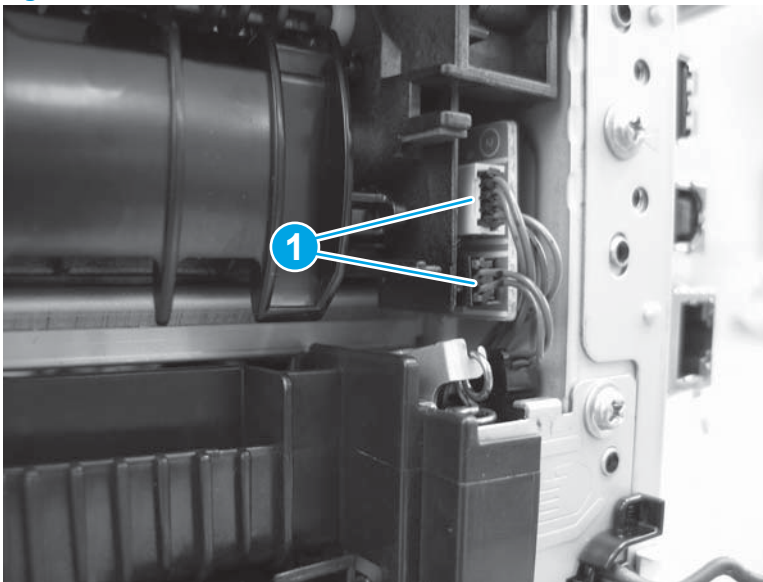

4. Remove four screws (callout 1).

Figure 1-659 Remove four screws

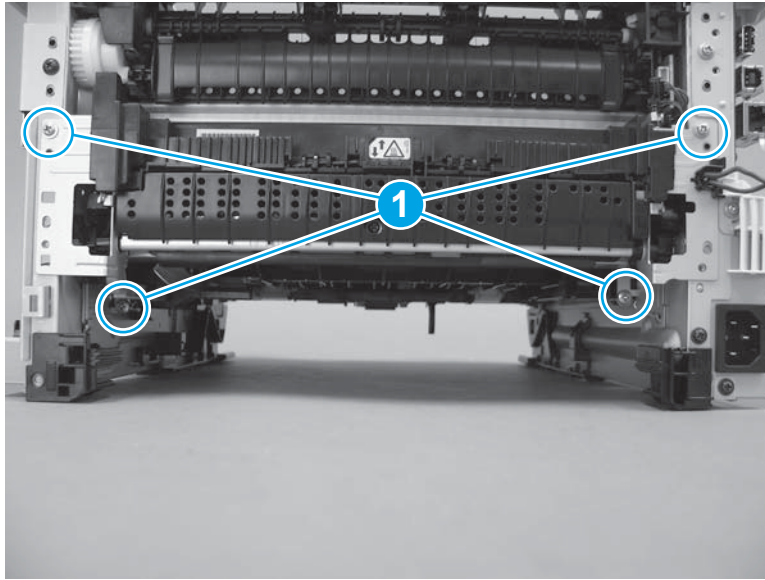

5. Pull the pressure-release link arm as shown to release it from the fuser.

Figure 1-660 Release the pressure-release arm

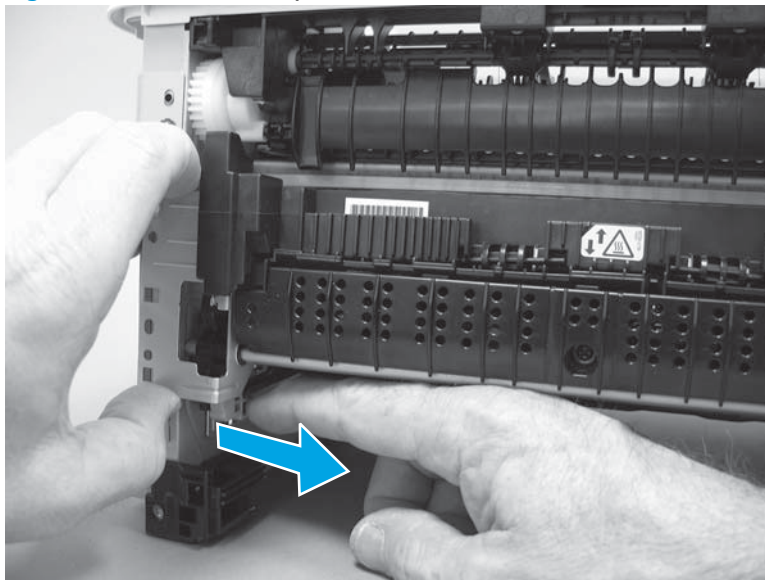

6. Slide the fuser straight out of the printer.

Figure 1-661 Remove the fuser

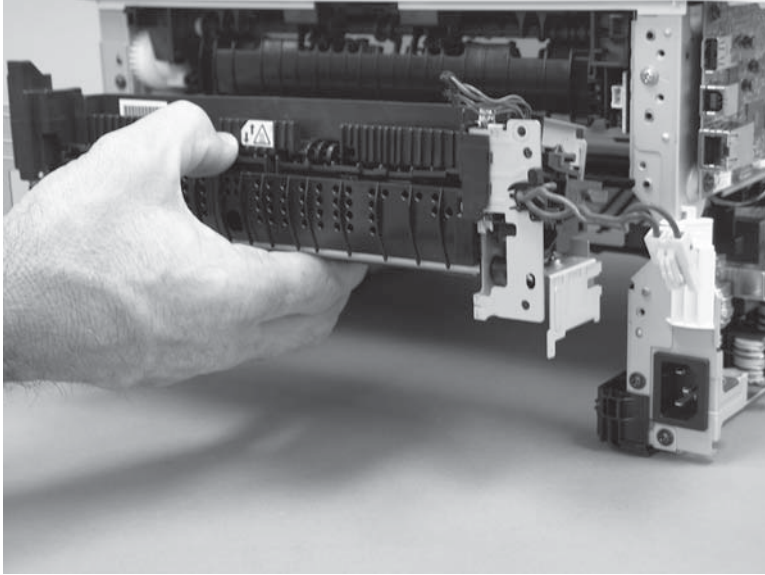

Step 12: Remove the registration assembly

1. Carefully rotate the printer backward until it rests on the rear side, bottom-side face forward.

CAUTION: The integrated scanner assembly (ISA) on the M427/M426 is not captive and can suddenly open when the printer is tilted backward. Support the ISA when handling the M427/M426 printer.

Figure 1-662 Place the printer bottom-side face forward

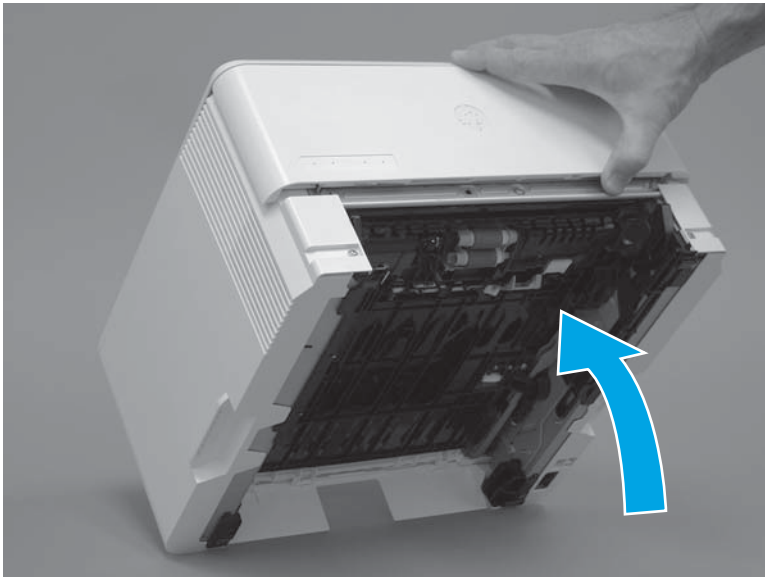

2. Remove one screw (callout 1), and then remove the guide (callout 2).

Figure 1-663 Remove one screw and the guide

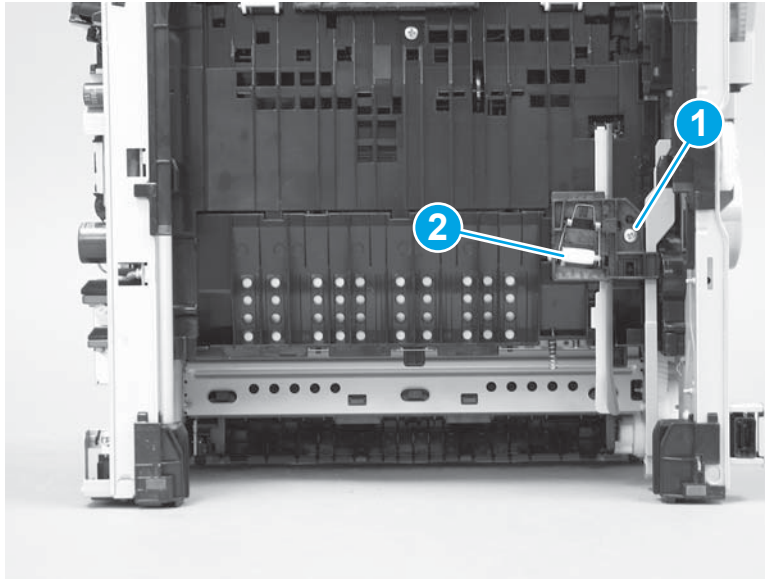

3. Move the end of pressure-release link arm out of the way.



NOTE: Doing this makes the other end of the pressure-release arm easier to move out of the way of the later in this procedure.

Figure 1-664 Move the link arm out of the way

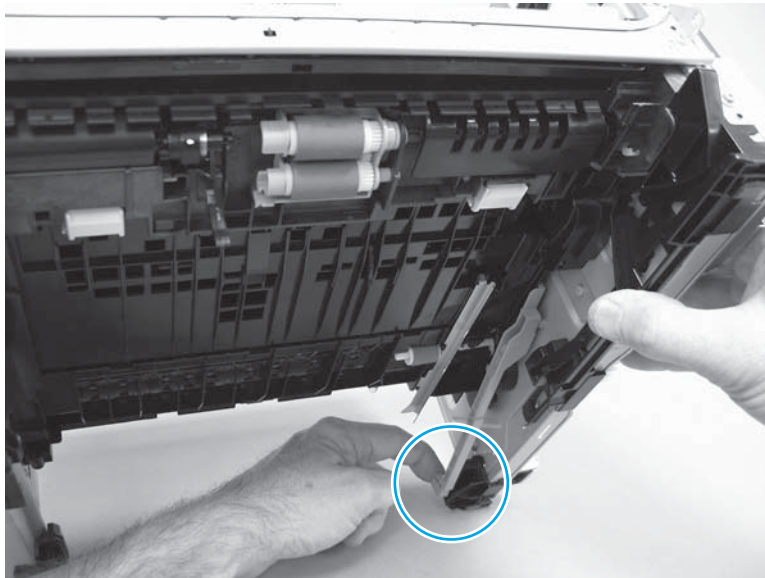

4. Place the printer with the bottom side down, look inside the toner-cartridge cavity, and then remove two screws (callout 1).

Figure 1-665 Remove two screws

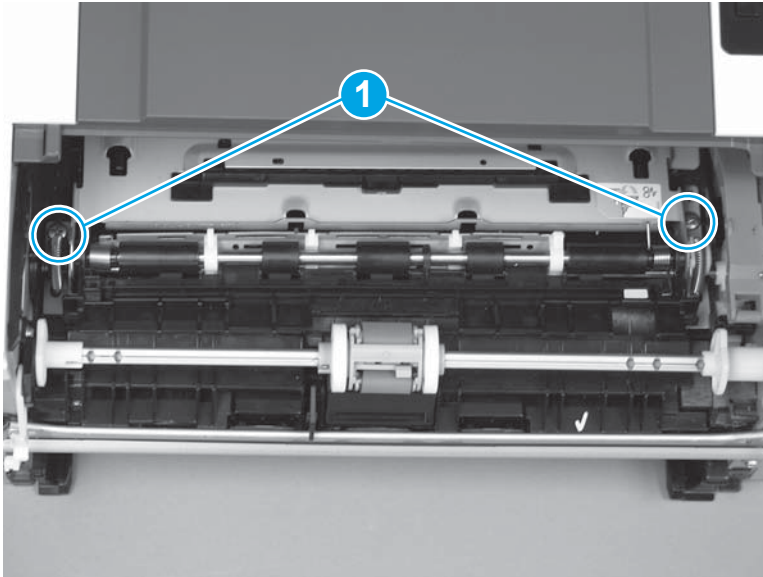

5. Move the end of pressure-release link arm (callout 1) out of the way.

Figure 1-666 Move the pressure-release arm out of the way

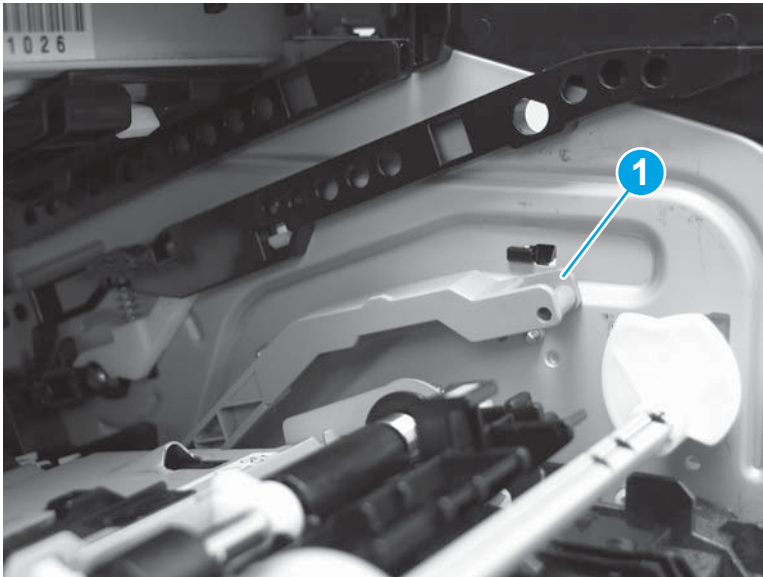

6. Rotate the left end of the registration up and out of the printer (callout 1), and then slide it to the left to release the gear end of the assembly (callout 2).

Figure 1-667 Release the assembly

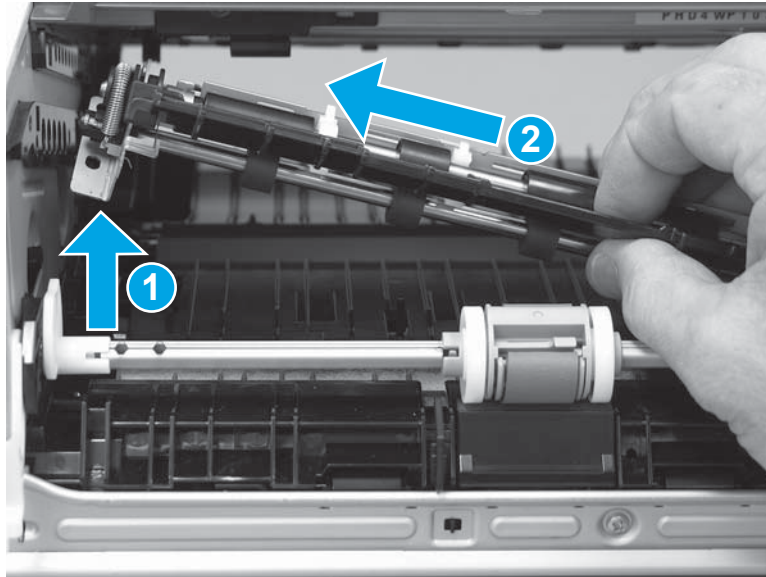

7. Remove the assembly.

Figure 1-668 Remove the assembly

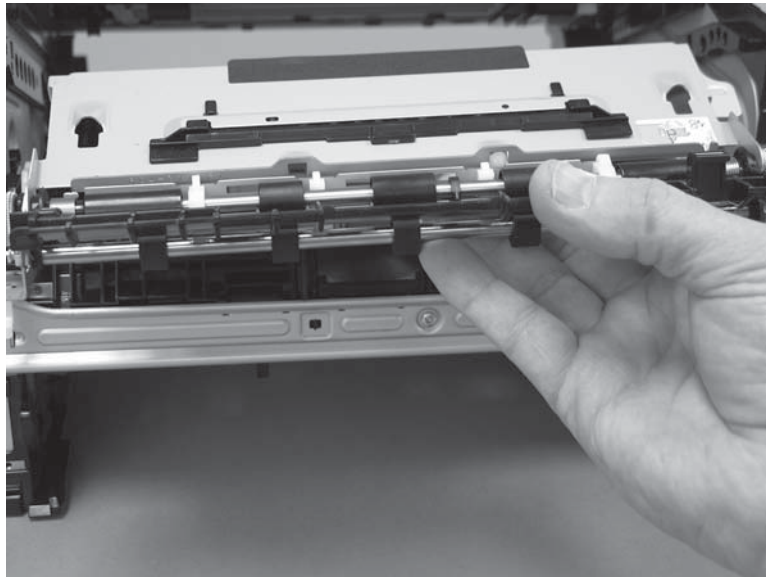

Step 13: Unpack the replacement assembly

Unpack the replacement part from the packaging.

<http://www8.hp.com/us/en/hp-information/environment/product-recycling.html>

 **NOTE:** HP recommends responsible disposal of the defective part.

Figure 1-669 Recycle and unpack

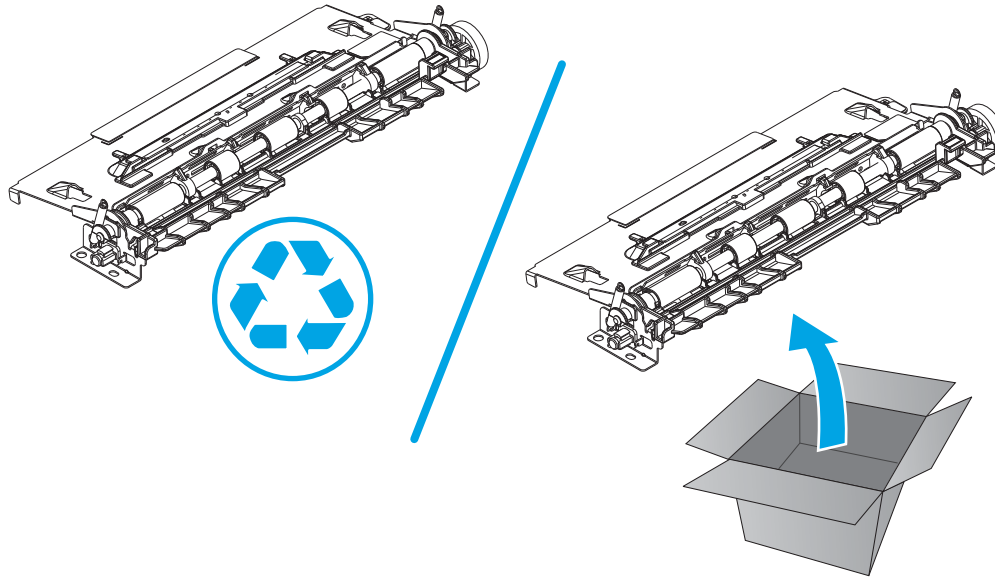

Step 14: Install the registration assembly

1. Position the gear end of the assembly in the printer (callout 1), and then rotate the left end of the registration down and into of the printer (callout 2).

Figure 1-670 Install the assembly

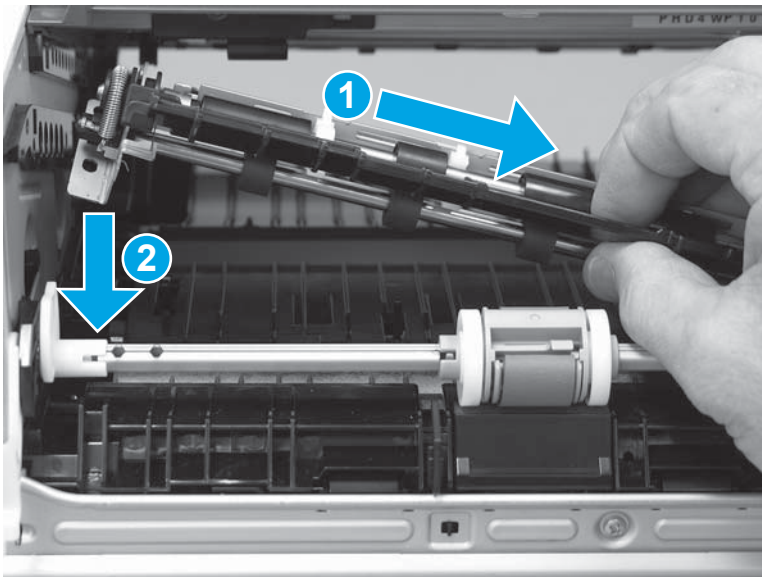

2. Install the end of pressure-release link arm (callout 1).

Figure 1-671 Install the pressure-release arm

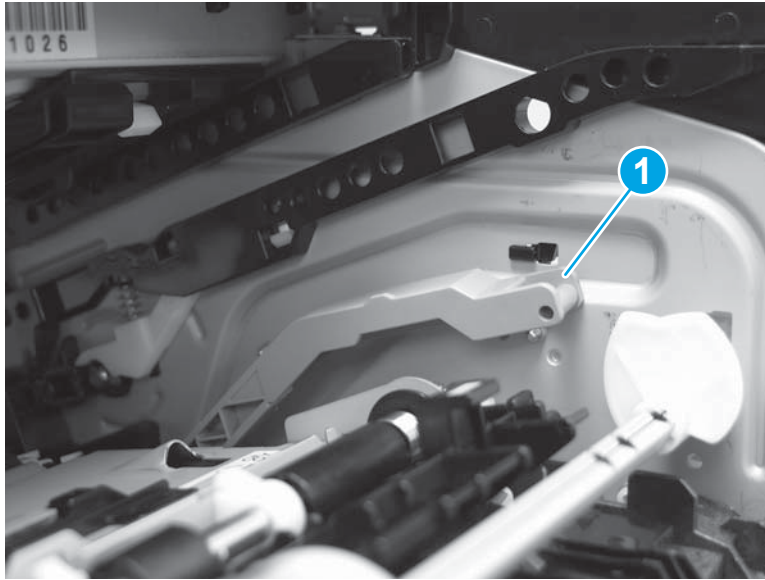

3. Install two screws (callout 1).

Figure 1-672 Install two screws

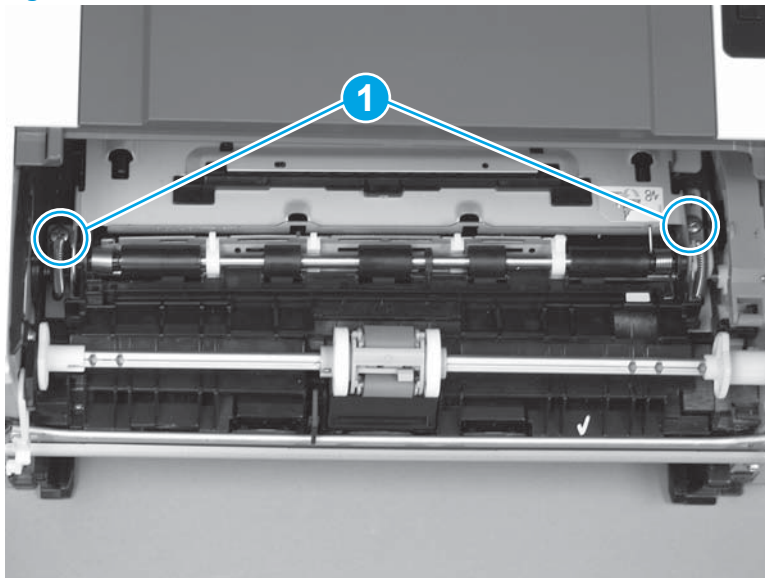

- Carefully rotate the printer backward until it rests on the rear side, bottom-side face forward.

⚠ CAUTION: The integrated scanner assembly (ISA) on the M427/M426 is not captive and can suddenly open when the printer is tilted backward. Support the ISA when handling the M427/M426 printer.

Figure 1-673 Place the printer bottom-side face forward

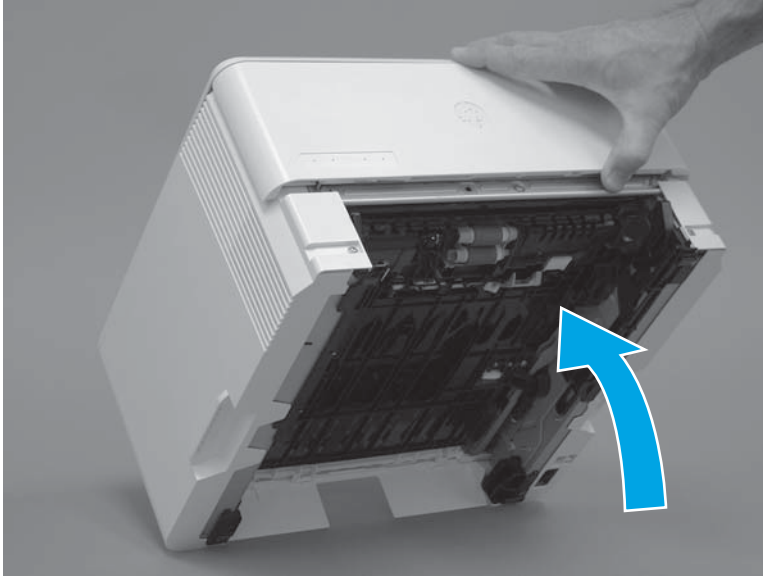

- Install the guide (callout 1), and then install one screw (callout 2).

Figure 1-674 Install the guide

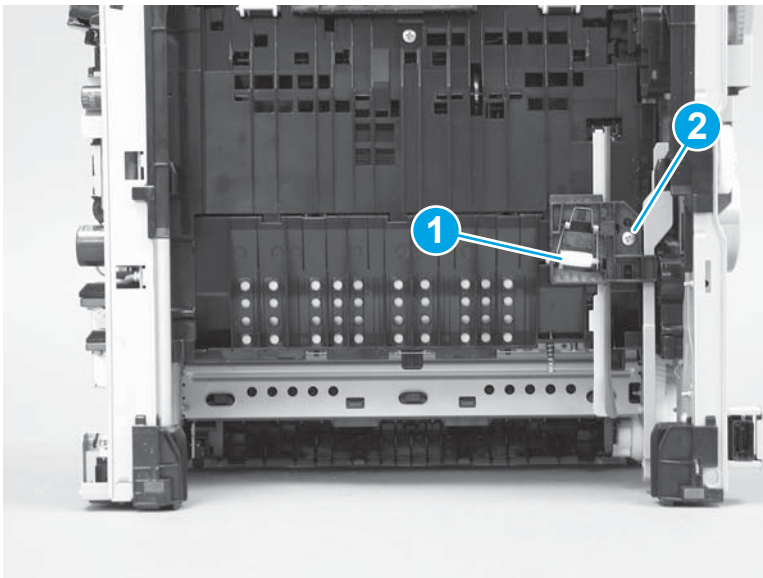

Step 15: Install the fuser

- Slide the fuser straight into the printer.

Figure 1-675 Install the fuser

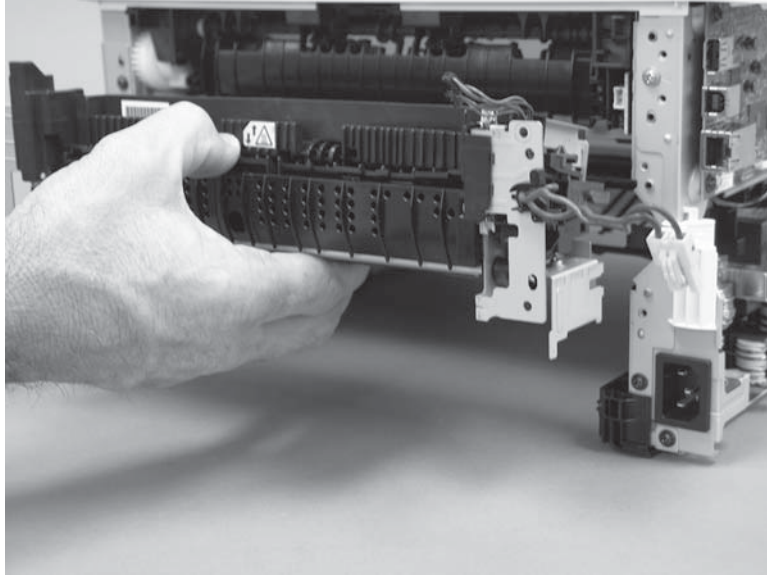

2. Connect the pressure-release link arm to the fuser.



IMPORTANT: Make sure that the pressure-release arm is correctly connected to the fuser.

Figure 1-676 Connect the pressure-release arm

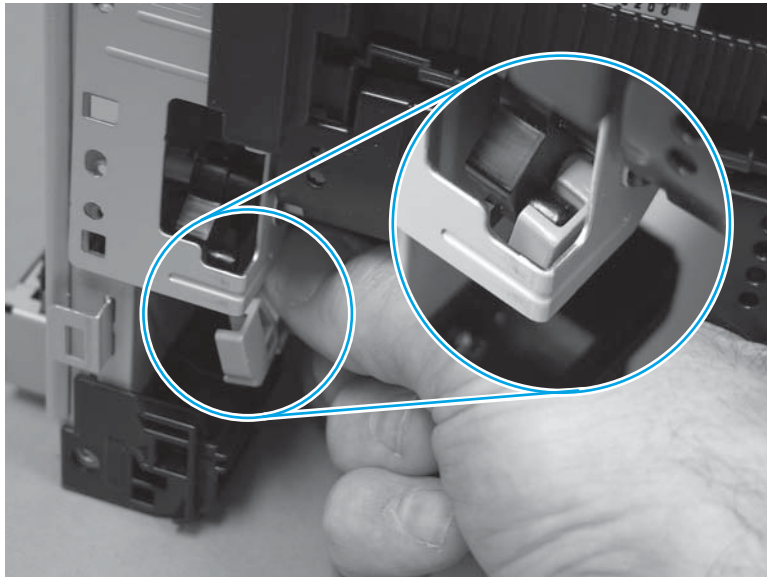

3. Install four screws (callout 1).

Figure 1-677 Install four screws

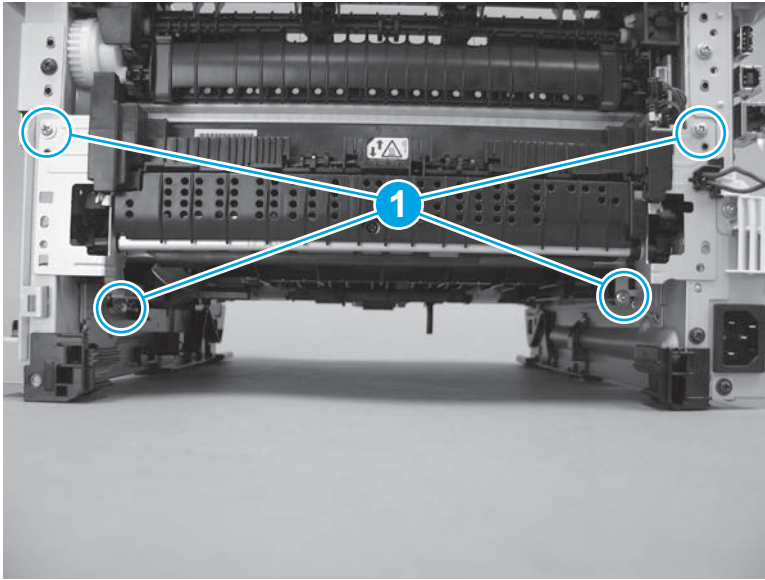

4. Connect two connectors (callout 1).

Figure 1-678 Connect two connectors

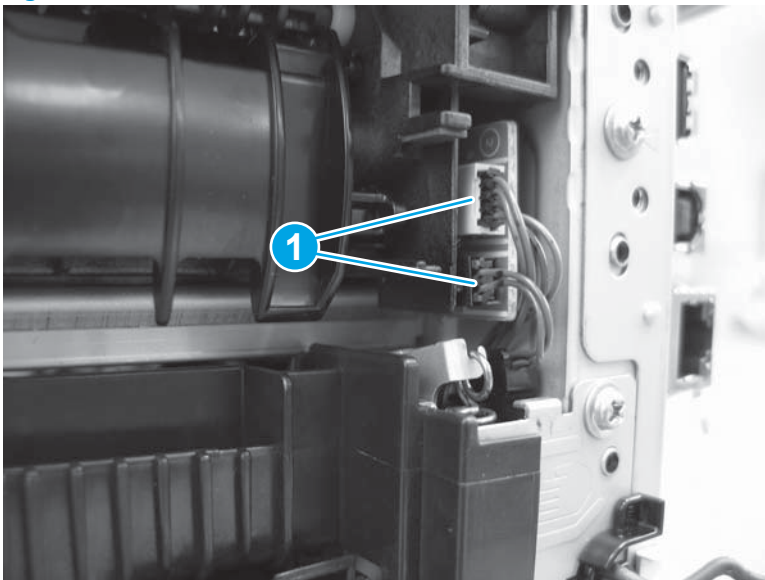

5. Push the upper connector cover (callout 1) straight onto of the printer to install it.

Figure 1-679 Install the cover

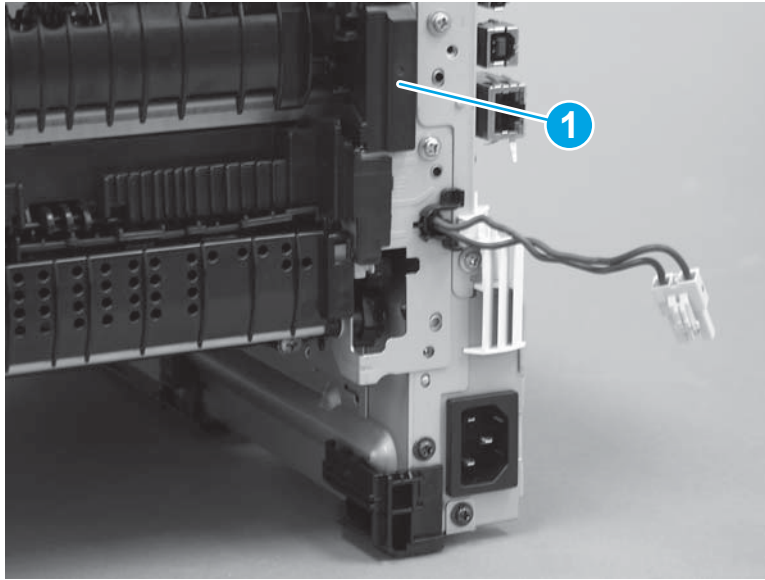

6. Install the wire harness in the guide (callout 1), and then connect one connector (callout 2).

Figure 1-680 Connect one connector

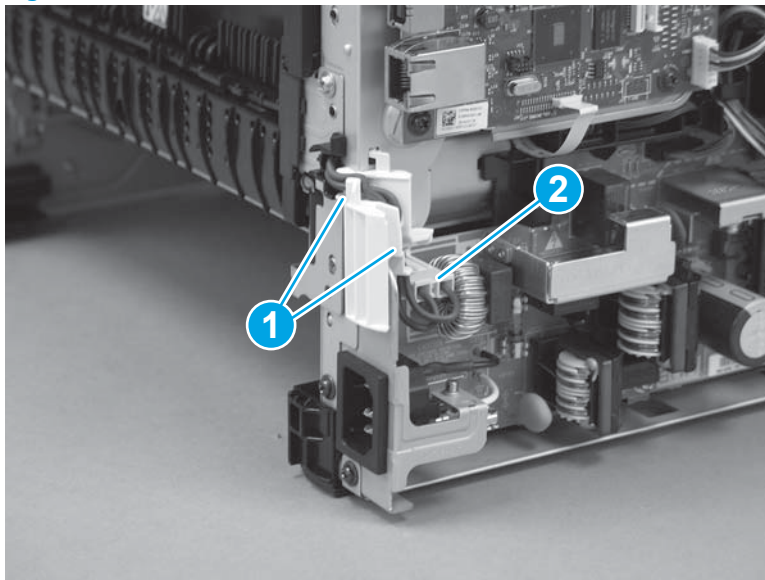

Step 16: Install the paper delivery tray (output bin)

 **NOTE:** This procedure shows the M403/M402 model, however, the paper delivery tray (output bin) removal is similar for the M427/M426 printer.

- ▲ Position the remove the paper delivery tray (output bin; callout 1) on the printer, engage two tabs (callout 2), and then engage two bosses (callout 3).

Figure 1-681 Engage two tabs

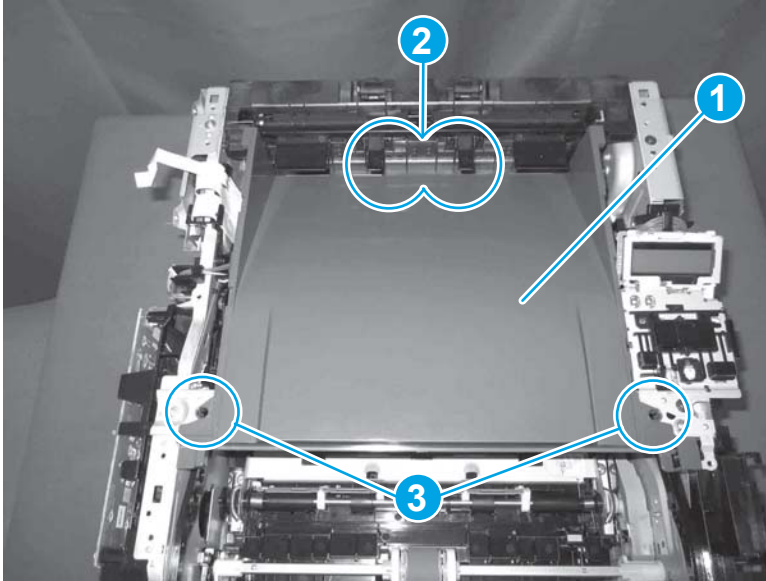

Step 17: Install the top cover (M403/M402)

 **NOTE:** The step is for the M403/M402 printer. For the M427/M426, skip this step and go to [Step 18: Install the top cover \(M427/M426\) on page 382](#).

1. Position the rear edge of the cover on the printer.

Figure 1-682 Install the cover

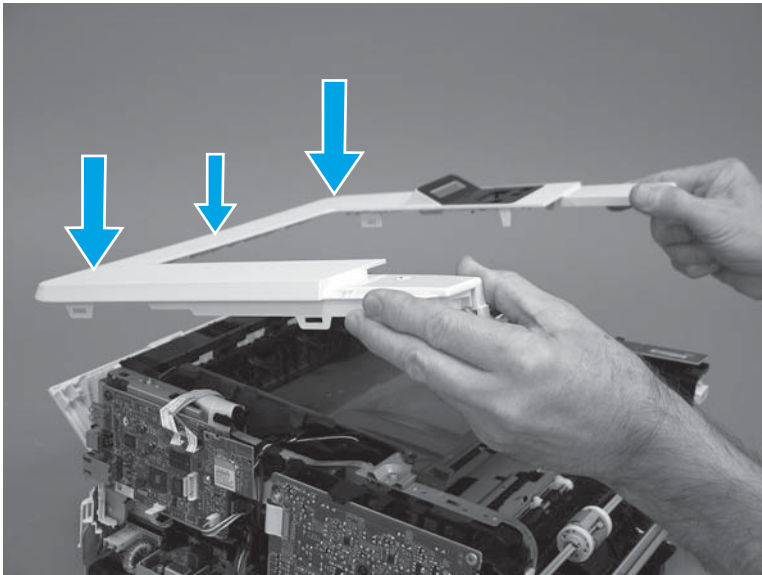

- Engage four bosses (callout 1), rotate the front of the cover down (callout 2) and onto from the printer, and then engage four tabs (callout 3).

Figure 1-683 Engage four bosses and tabs

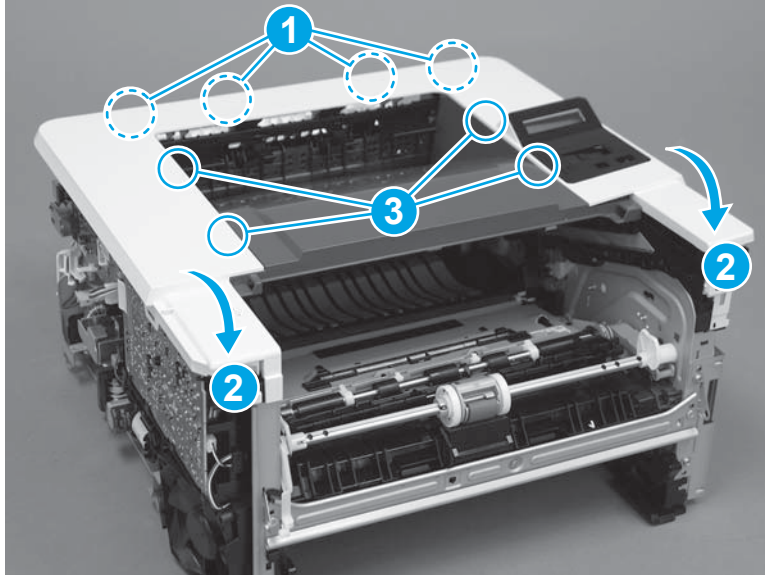

- At the right side of the printer, engage the one boss and one tab (callout 1).

Figure 1-684 Engage one boss and one tab

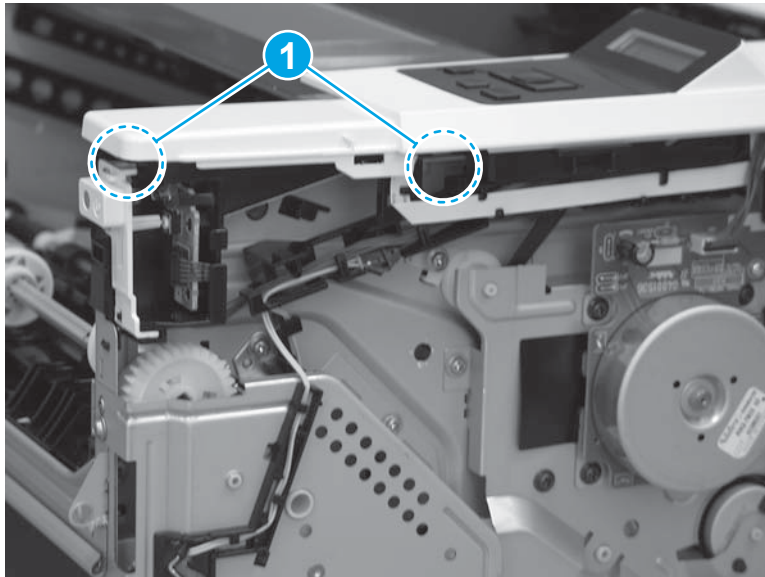

4. Install one screw (callout 1).

Figure 1-685 Install one screw

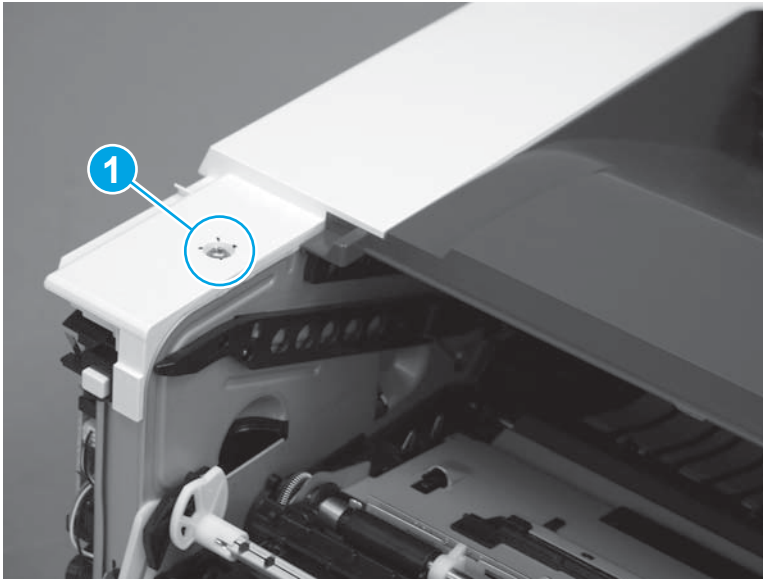

Step 18: Install the top cover (M427/M426)

 **NOTE:** The step is for the M427/M426 printer. For the M403/M402, skip this step and go to [Step 21: Install the rear door assembly on page 393](#).

1. Position the rear edge of the top cover on the printer.

Figure 1-686 Install the cover

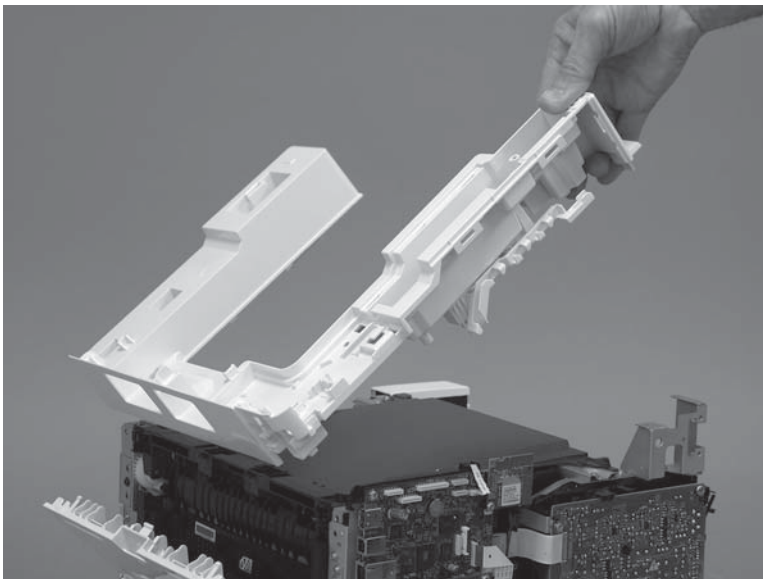

2. Engage four bosses (callout 1).

Figure 1-687 Engage four bosses

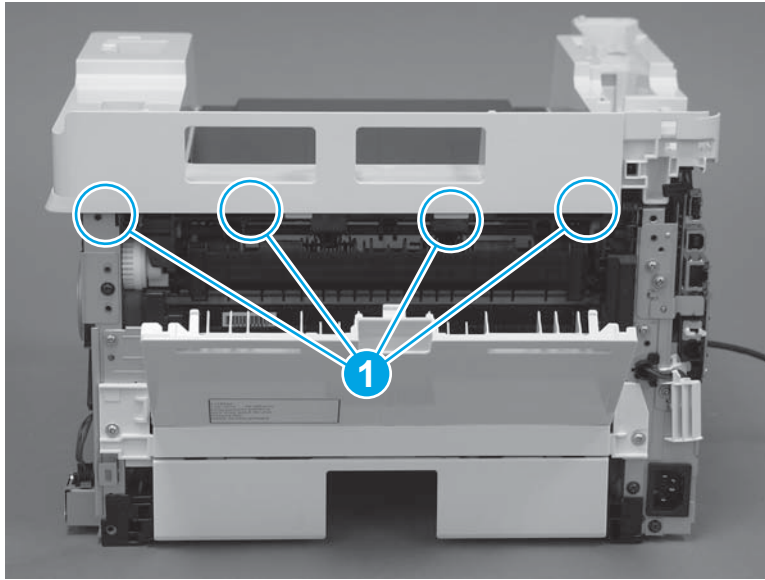

3. Rotate the front edge of the cover down.

Figure 1-688 Rotate the front edge of the cover down

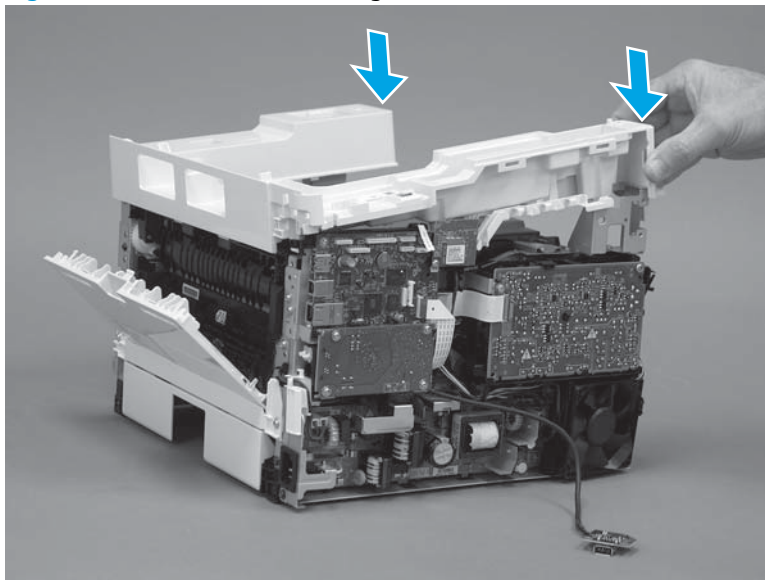

4. Install the USB cable (callout 1) in the guide.

Figure 1-689 Install the USB PCA

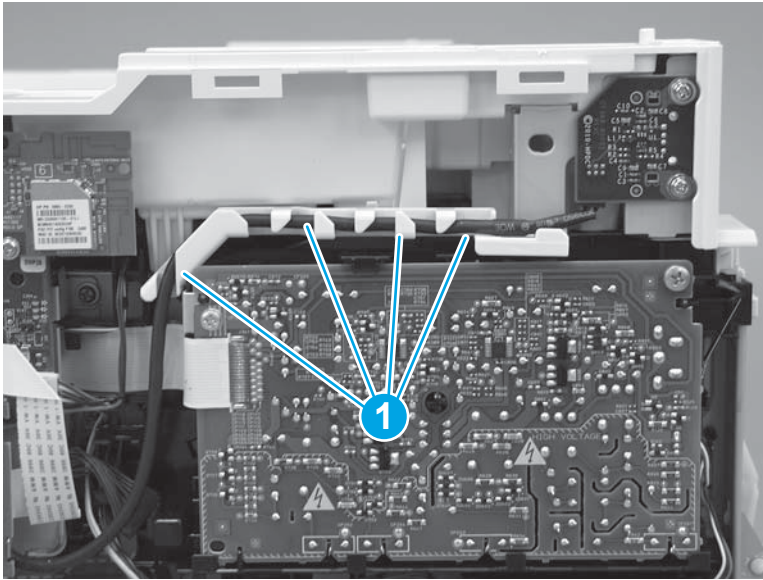

5. Install five screws (callout 1).

Figure 1-690 Install five screws

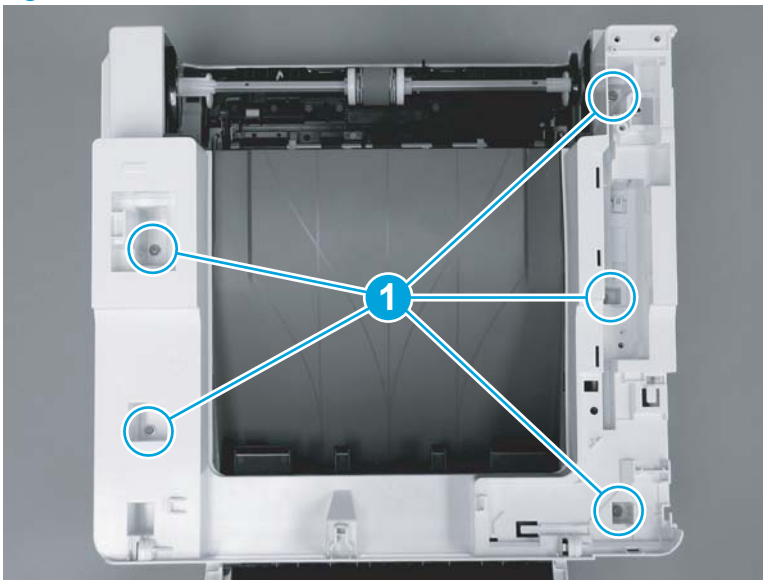

Step 19: Install the control panel (M427/M246)

 **NOTE:** The step is for the M427/M426 printer. For the M403/M402, skip this step and go to [Step 21: Install the rear door assembly on page 393](#).

1. Slide the control-panel FFC cover into the slot in the top cover (next to the document feeder support arm) to install it.

Figure 1-691 Install the control-panel FFC cover

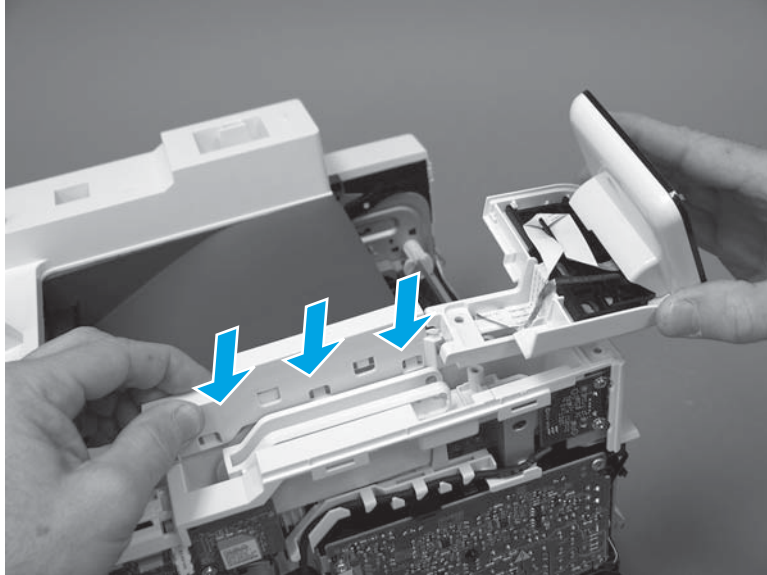

2. Install the control-panel assembly on the top cover.

Figure 1-692 Install the control-panel assembly

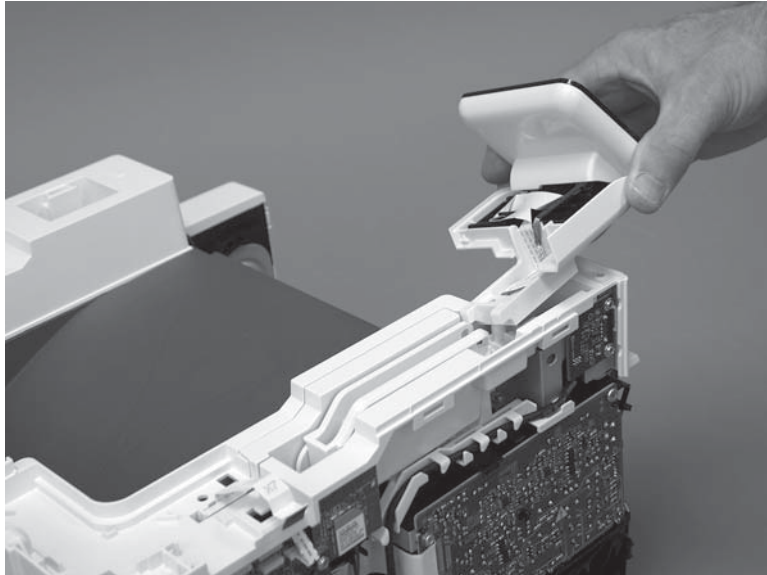

3. Move the FFC out of the way, and then install two screws (callout 1).

Figure 1-693 Install two screws

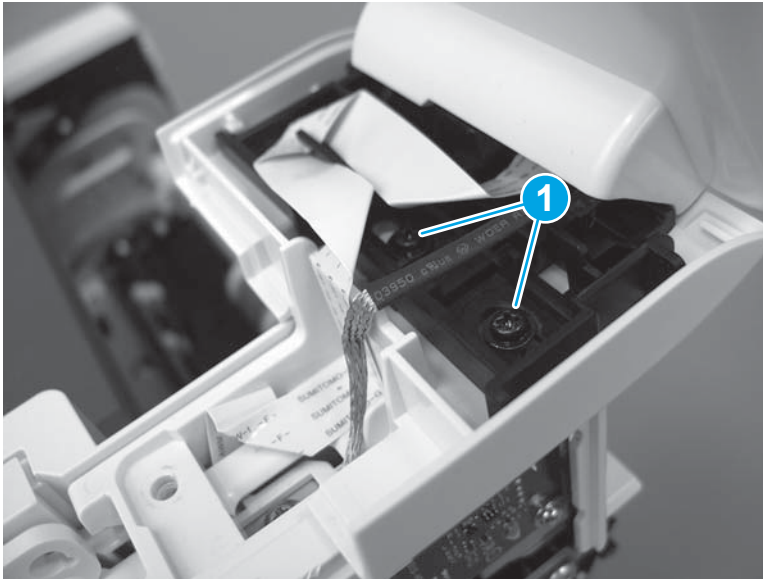

4. Install one grounding screw (callout 1), and then make sure that the ground cable (callout 2) is properly routed.

Figure 1-694 Remove one screw

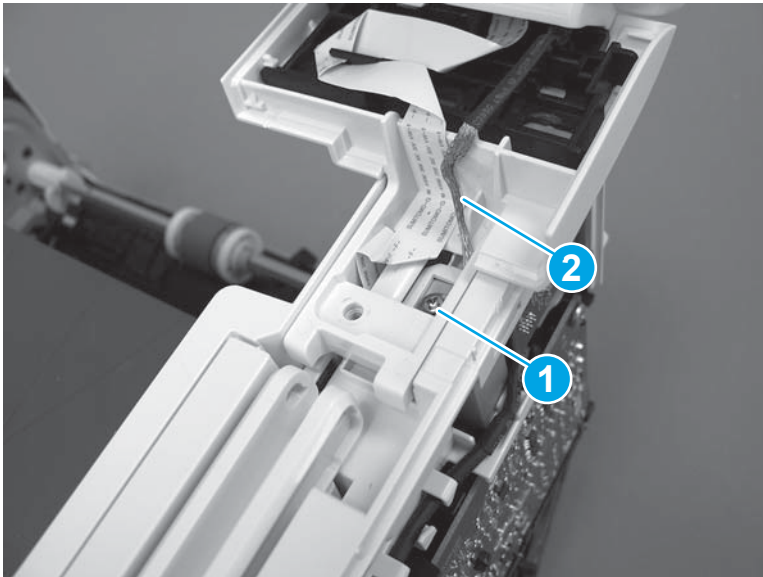

5. Install the control-panel cable cover.

Figure 1-695 Install the cover

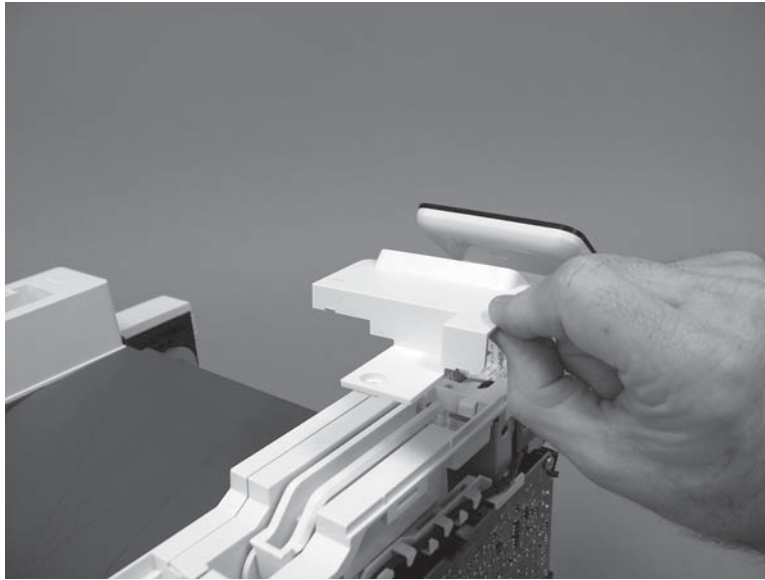

6. Make sure that the two tabs (callout 1) on the cover snap into place.

Figure 1-696 Engage two tabs

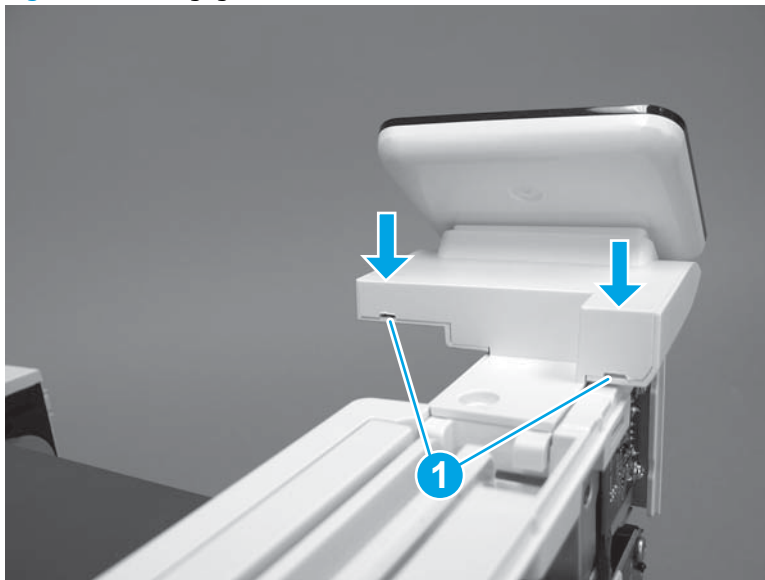

7. Install one screw (callout 1).

Figure 1-697 Install one screw

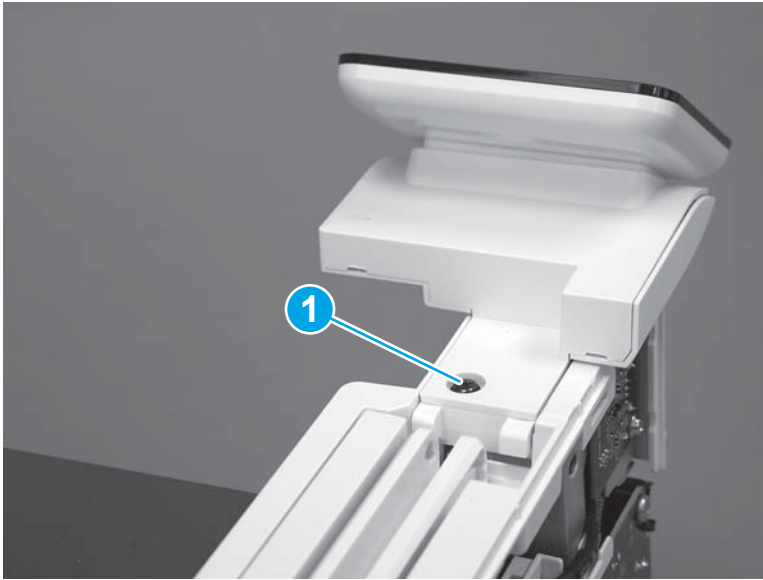

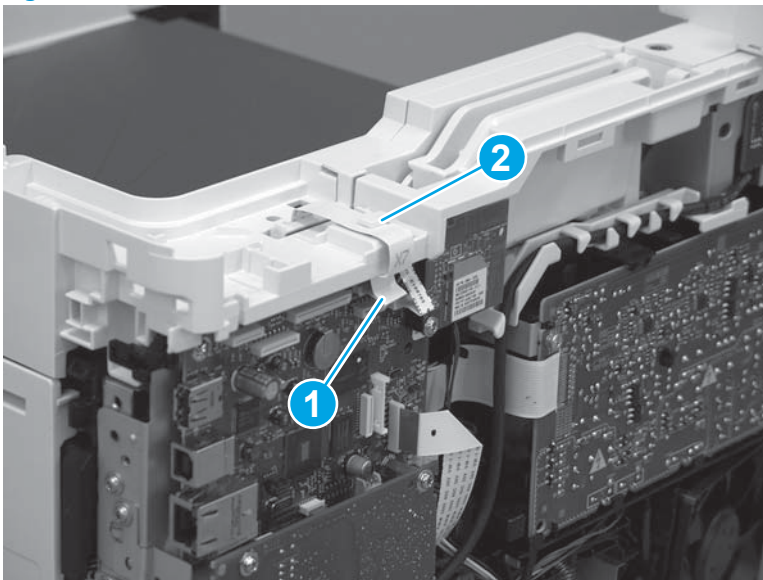

8. Install the FFC in the retainer (callout 1), and then connect one FFC (callout 1; J114).

Figure 1-698 Connect one connector



Step 20: Install the integrated scanner assembly (M427/M246)

 **NOTE:** The step is for the M427/M426 printer. For the M403/M402, skip this step and go to [Step 21: Install the rear door assembly on page 393](#).

 **NOTE:** M427/M426 models only. The integrated scanner assembly (ISA) includes the sub-scanner assembly (SSA) and the automatic document feeder (ADF).

1. Position the ISA on the printer.

Figure 1-699 Position the ISA on the printer

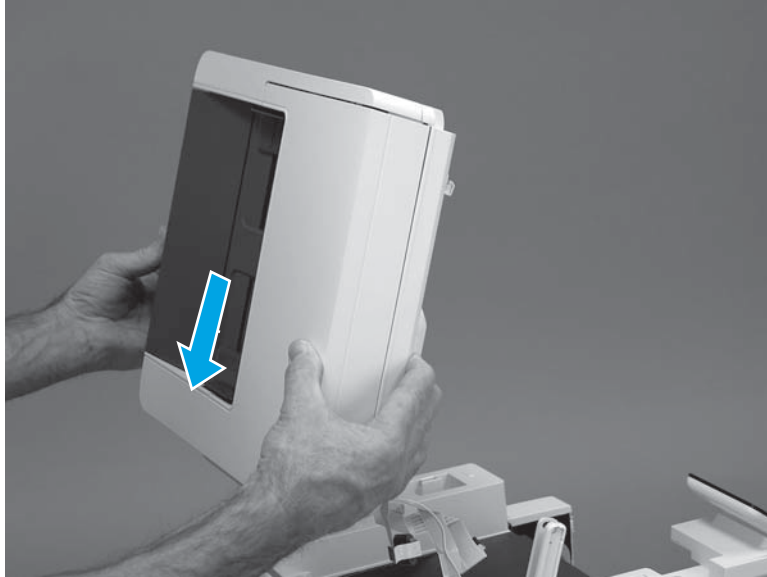

2. Engage the hinge pins on the ISA with the holders in the top cover (callouts 1/2), and then slide the ISA as shown to engage them

Figure 1-700 Engage the hinge pins with the holders

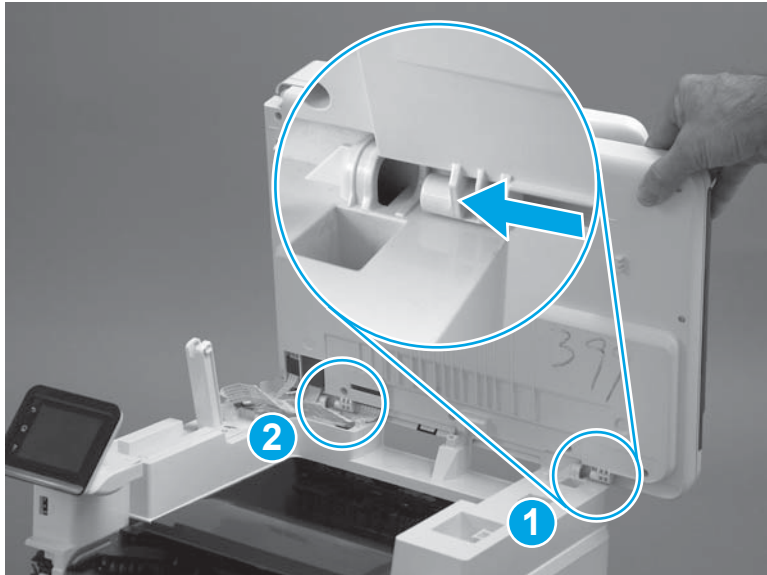

3. Rotate the ISA towards the front of the printer until it rests on the ISA lift assembly (callout 1).

Figure 1-701 Rotate the ISA towards the front of the printer

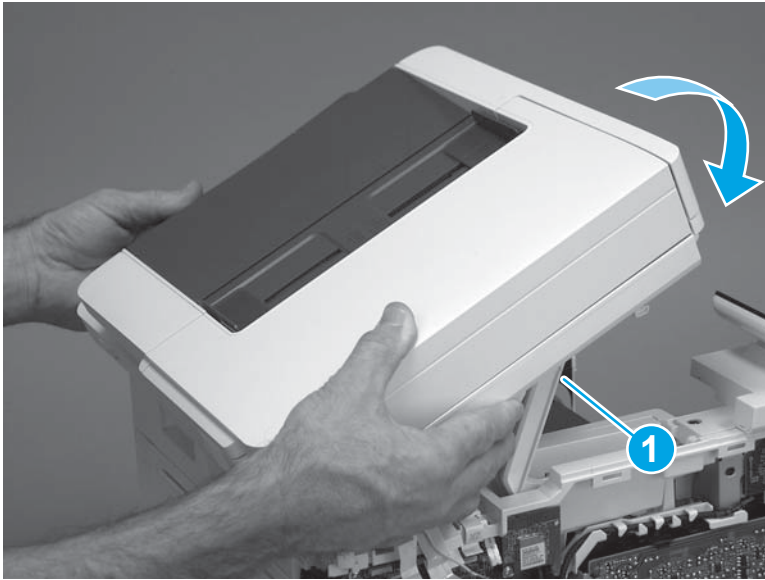

4. Pass the ground wire through the opening in the top cover.

Figure 1-702 Pass the wire through the opening

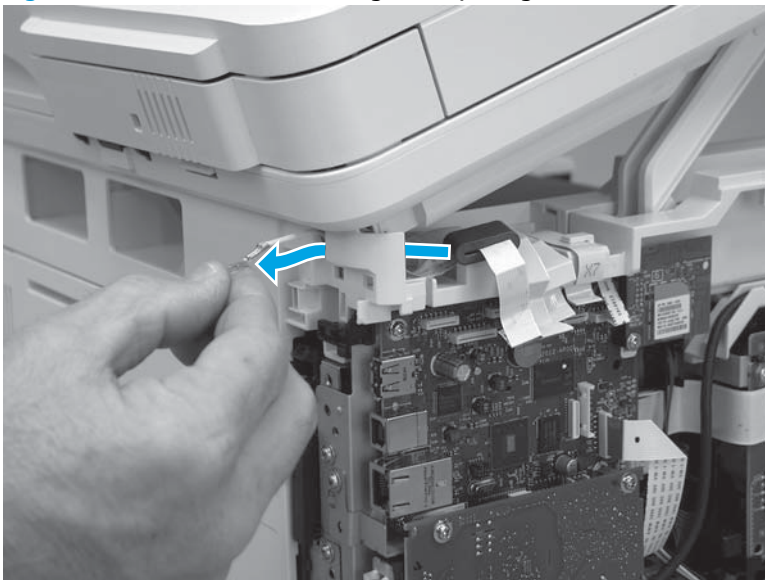

5. Install one screw (callout 1).

Figure 1-703 Install one screw

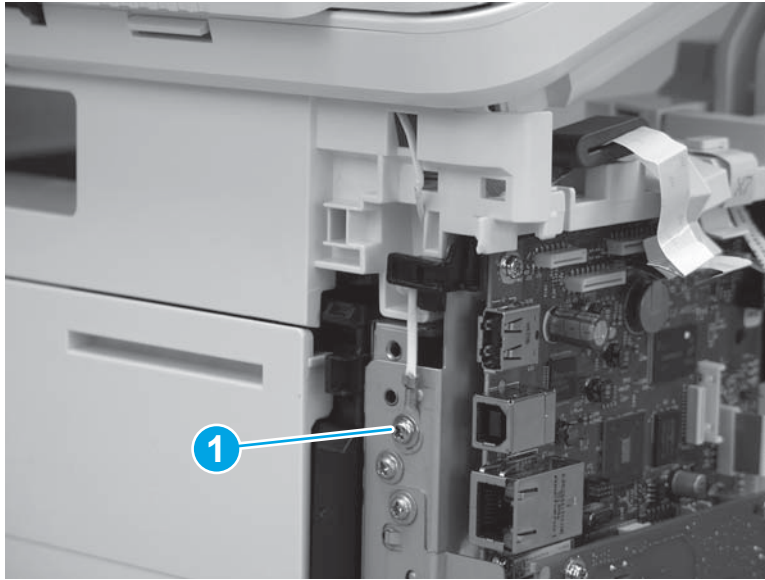

6. Install the ISA lift assembly slider pin.

 **Reinstallation tip:** Align the keyed portion of the locking pin with the slot and hole in the support arm.

Figure 1-704 Install the slider pin



7. Rotate the slider pin (callout 1) towards the rear of the printer until the tab (callout 2) snap into place.

Figure 1-705 Secure the slider pin

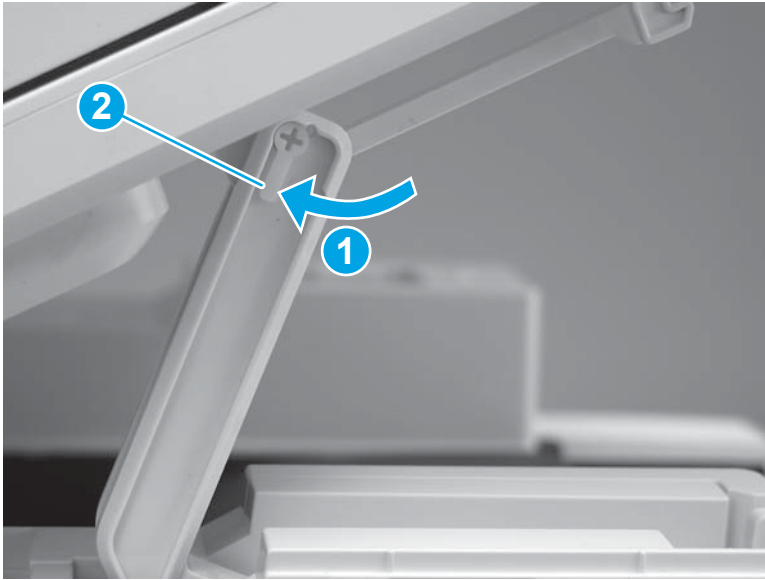

8. Install the ferrite (callout 1) in the holder, and then connect three FFCs (callout 2).

Figure 1-706 Connect three FFCs

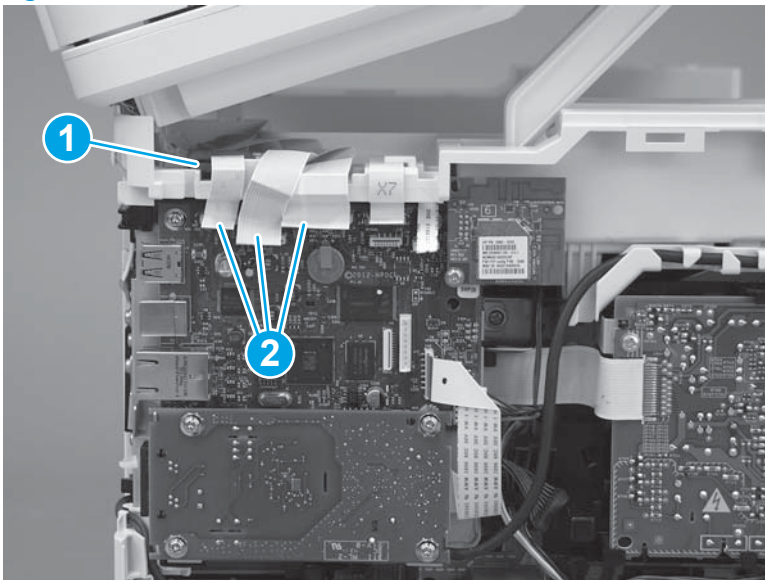

9. Position the rear edge of the ISA flat-flexible cable (FFC) cover on the printer (callout 1) , and then rotate it down (callout 2) until it snaps into place.

Figure 1-707 Install the ISA FFC cover

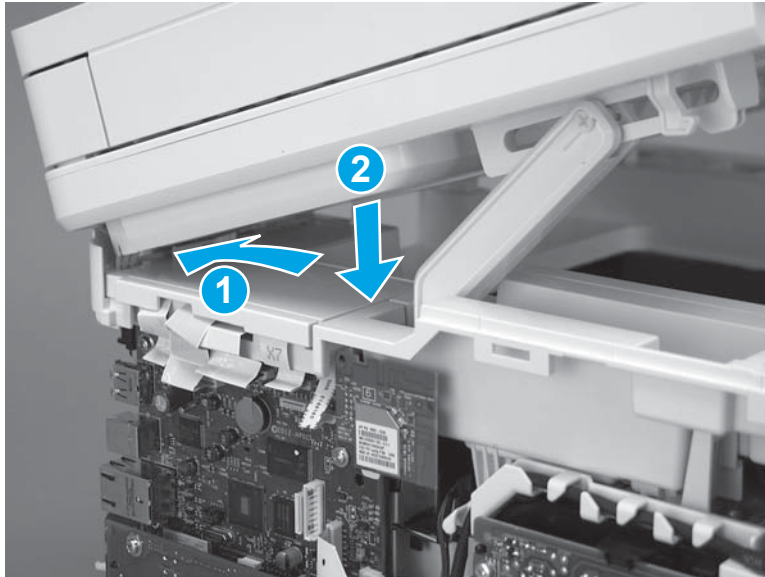

10. Lower the ISA.

Figure 1-708 Lower the ISA

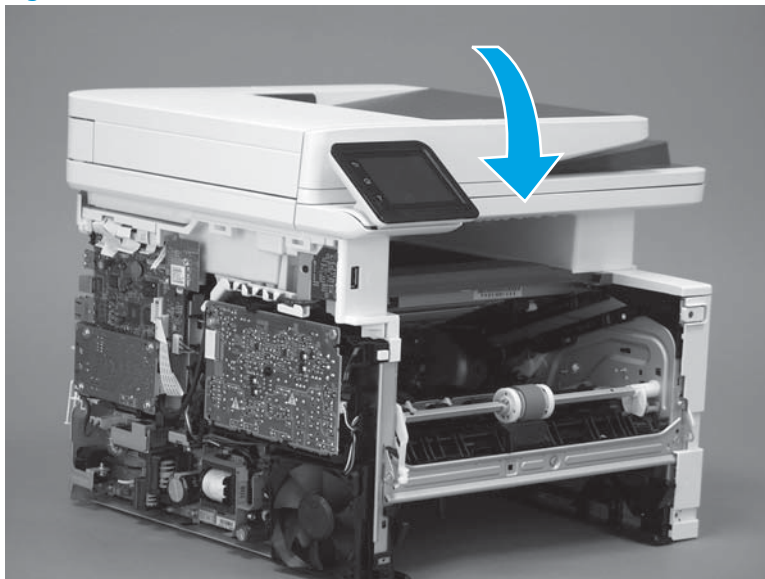

Step 21: Install the rear door assembly

1. At the rear of the printer, position the assembly so that the two tabs (callout 1) are installed in the slots (callout 2) in the chassis.

 **NOTE:** **Duplex models only:** Slide the duplex tray into the Tray 2 cavity.

Figure 1-709 Install the rear cover



2. Install two screws.

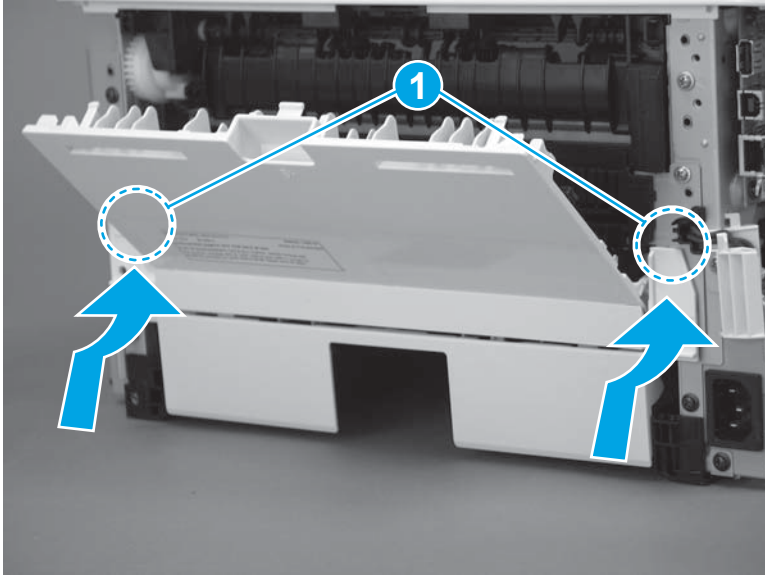

NOTE: Duplex models only: Reach in from the front of the Tray 2 cavity and raise the feed assembly to the up and locked position so that the rear cover will fit flat against the chassis.

Figure 1-710 Install two screws



Step 22: Install the right cover

1. Position the cover (callout 1) on the printer, and then engage two bosses (callout 2).

Figure 1-711 Install the cover

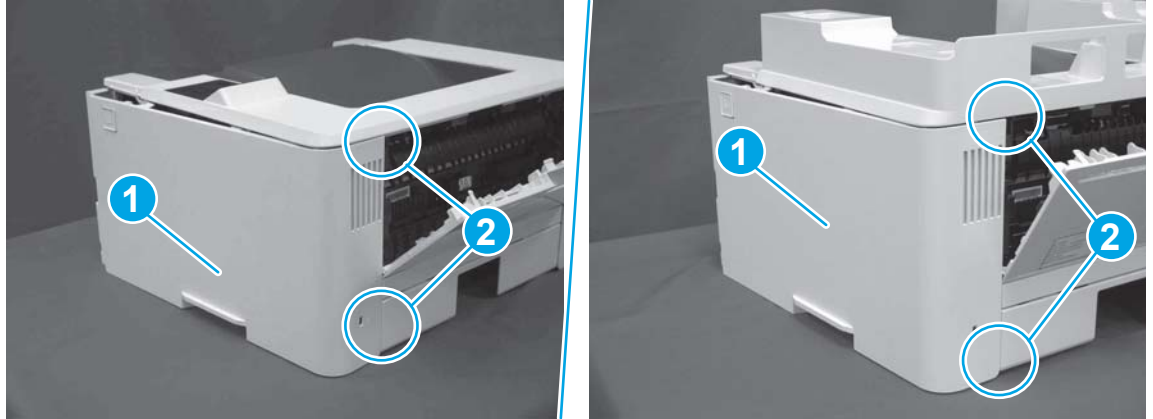

2. Rotate the front of the cover onto the printer (callout 1), engage three (callout 2) tabs, and then engage two bosses (callout 3).

Figure 1-712 Engage two bosses and one tab

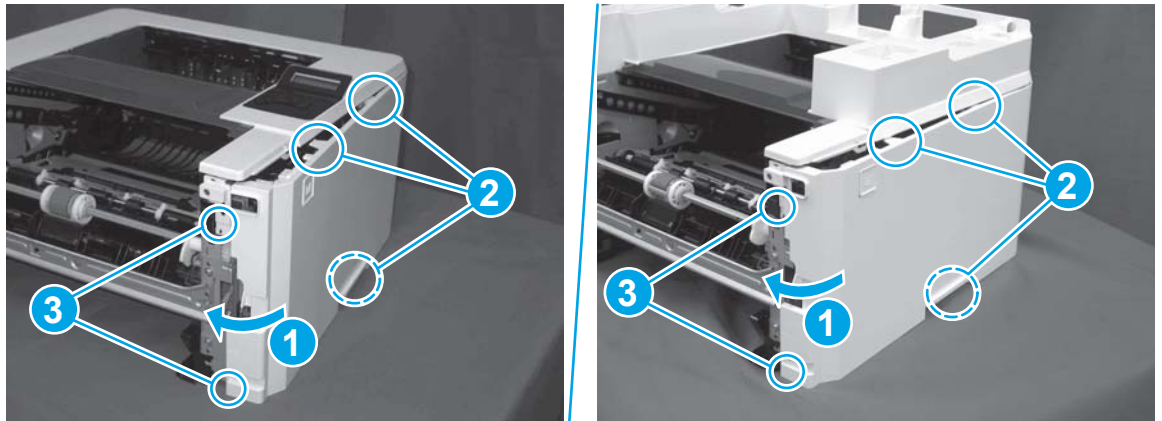

3. Make sure that the power switch (callout 1) and cartridge door assembly button (callout 2) correctly function.



NOTE: Remove, and then reinstall the cover if the switch or button does not correctly function.

Figure 1-713 Check the power switch and cartridge door assembly button

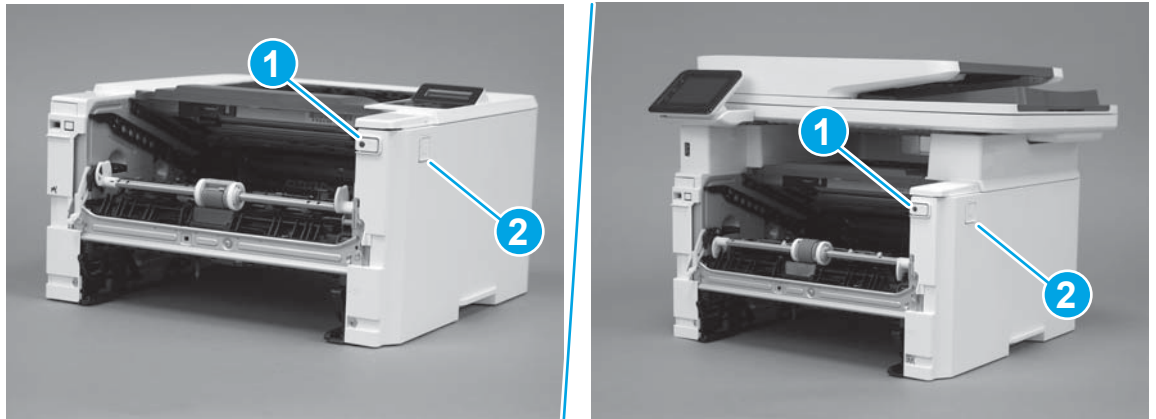

4. Install one screw (callout 1).

Figure 1-714 Install one screw



Step 23: Install the left cover

1. At the front of the printer, do one of the following:
 - **M403/M402:** Position the cover on the printer (callout 1), and then engage two bosses (callout 2).
 - **M427/M426:** Position the cover on the printer (callout 3), engage one tab (callout 4), and then engage two bosses (callout 4).

Figure 1-715 Install the cover

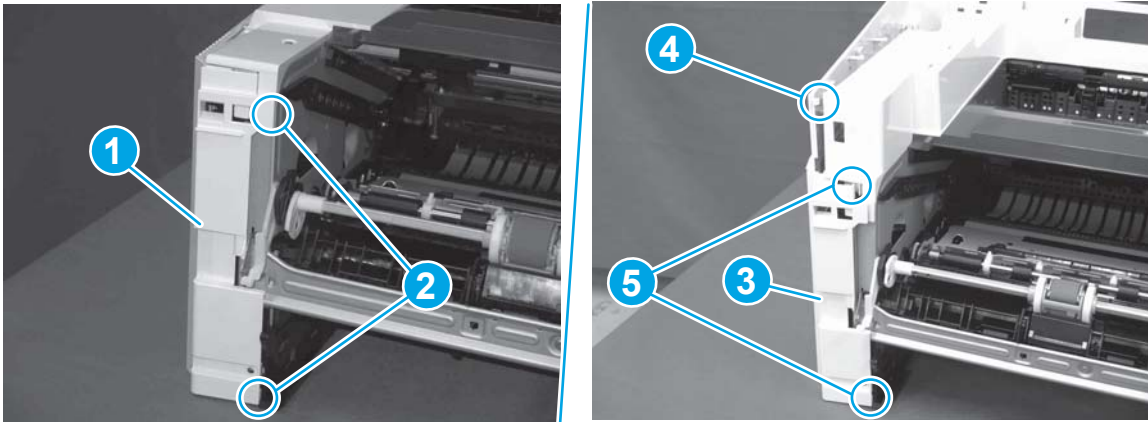

- Carefully rotate the rear of the cover onto the printer (callout 1), engage three tabs (callout 2), and then engage two bosses (callout 3).

Figure 1-716 Engage three tabs and two bosses

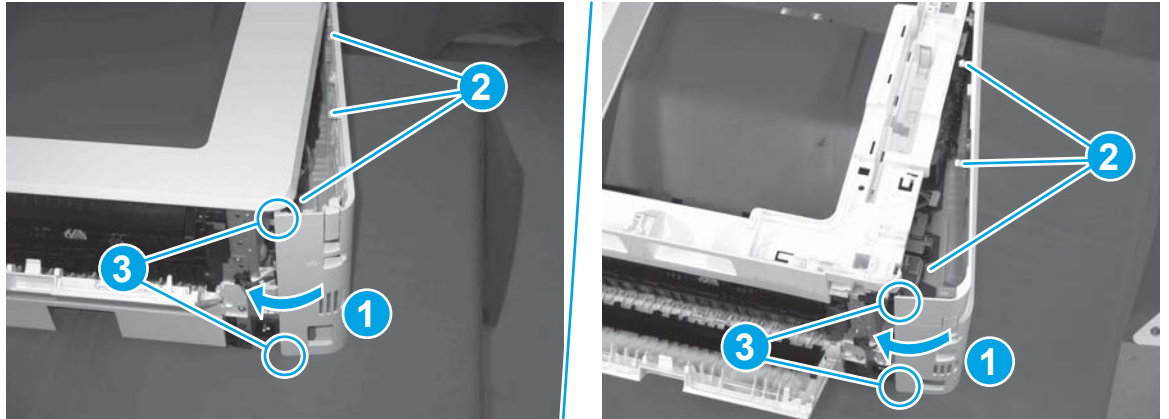

- Install one screw (callout 1).

Figure 1-717 Install one screw

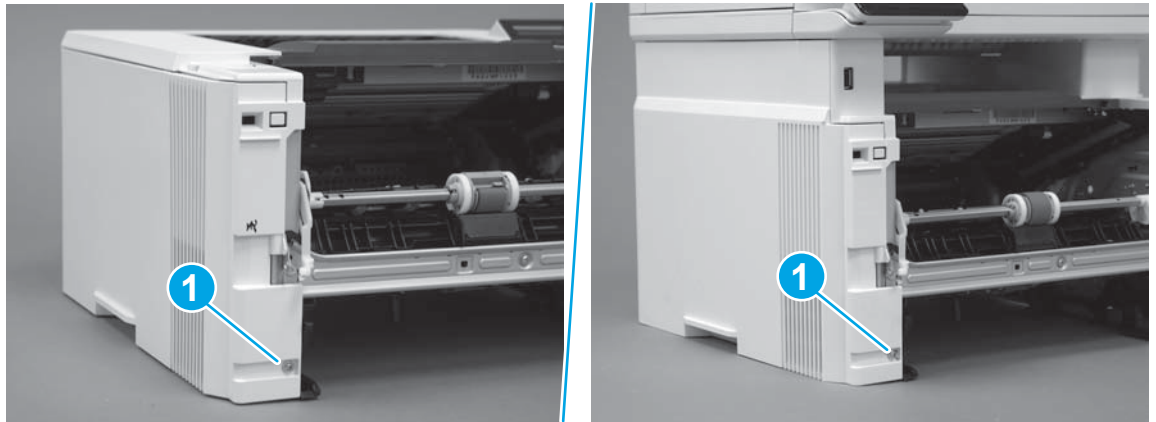

Step 24: Install the cartridge door assembly

 **Reinstallation tip:** After a replacement door is installed, make sure to install the nameplate (supplied in the kit) corresponding to the printer name on the door.

- Position the door close to the printer, and then engage the keyed pin on the left-side retainer arm with the hole in the door.

Figure 1-718 Engage the left-side retainer arm

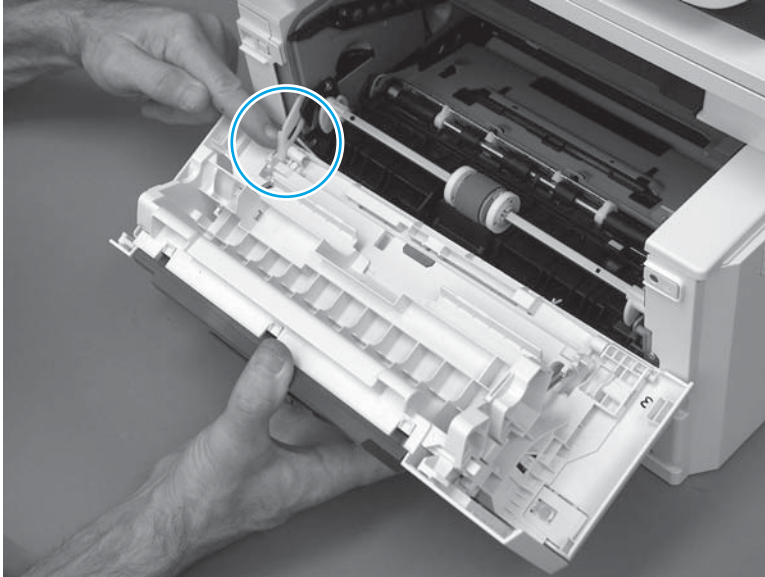

2. Engage the right-side door hinge pin with the hole in the chassis (callout 1).

Figure 1-719 Install the door

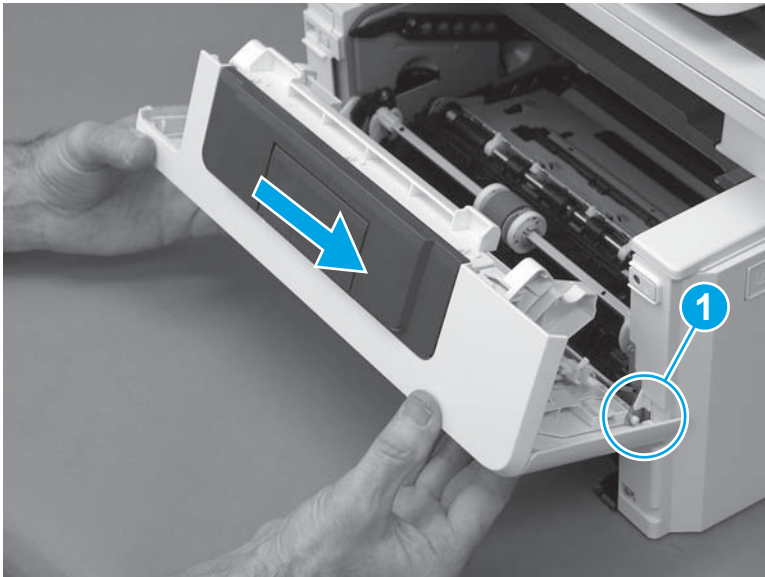

3. Install the link (callout 1).

 **IMPORTANT:** Make sure that the link snaps into place on the arm (callout 2). The link actuates the fuser pressure-release mechanism.

Figure 1-720 Install the pressure-release link

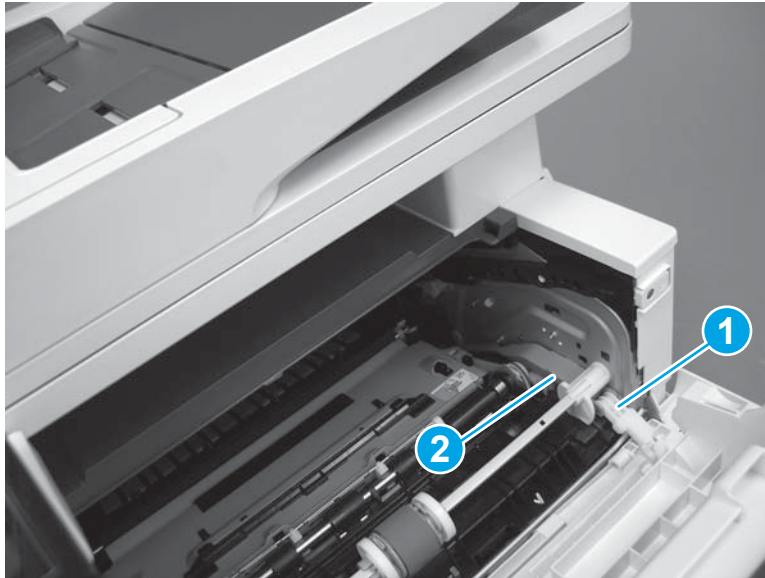

4. Slide the guide into the printer (callout 1), and then make sure that the tab (callout 2) snaps into place to secure the guide to the chassis.

Figure 1-721 Install the guide

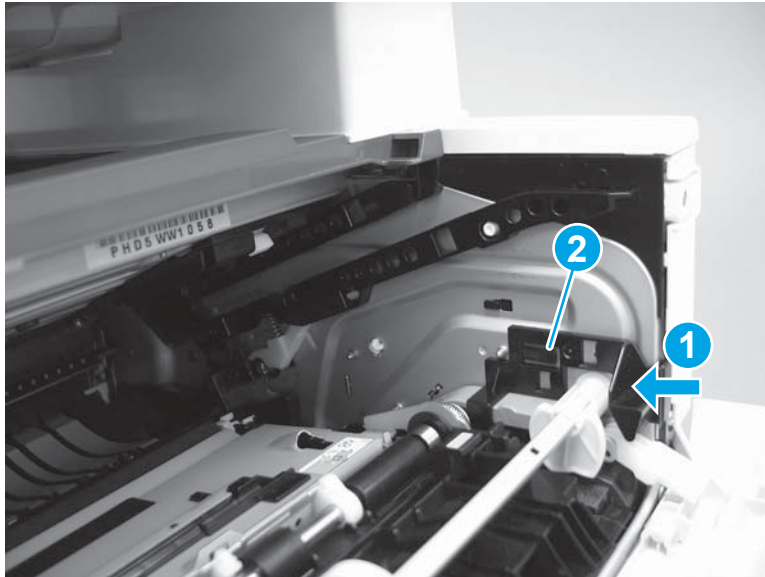

5. Position the shaft on the door, and then align the left-side hinge on the door with the hole in the chassis (callout 1).

Figure 1-722 Align the hinge

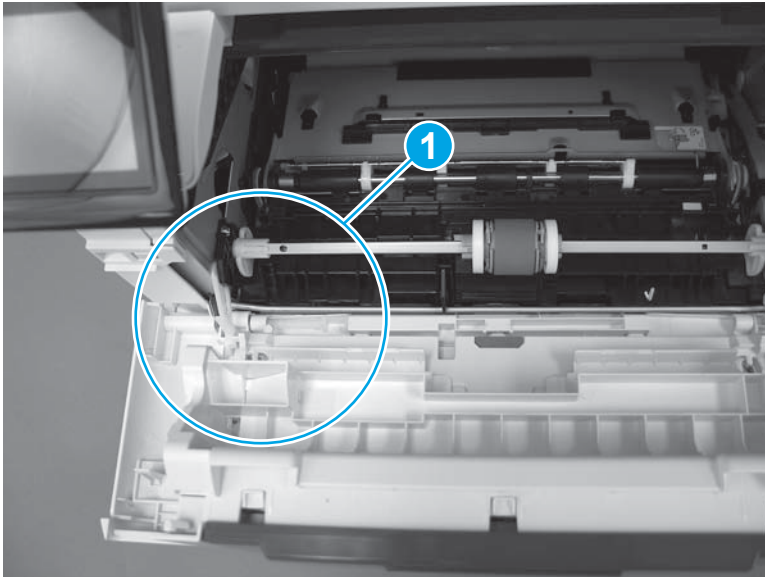

6. Push the shaft towards the left side of the printer to install it (callout 1).

 **Reinstallation tip:** Make sure that the support shaft is fully installed and correctly orientated (callout 2) so that it will not interfere with the door opening and closing.

Figure 1-723 Install the support shaft



Step 25: Install Install Tray 2

- ▲ Slide the tray straight into the printer to install it.

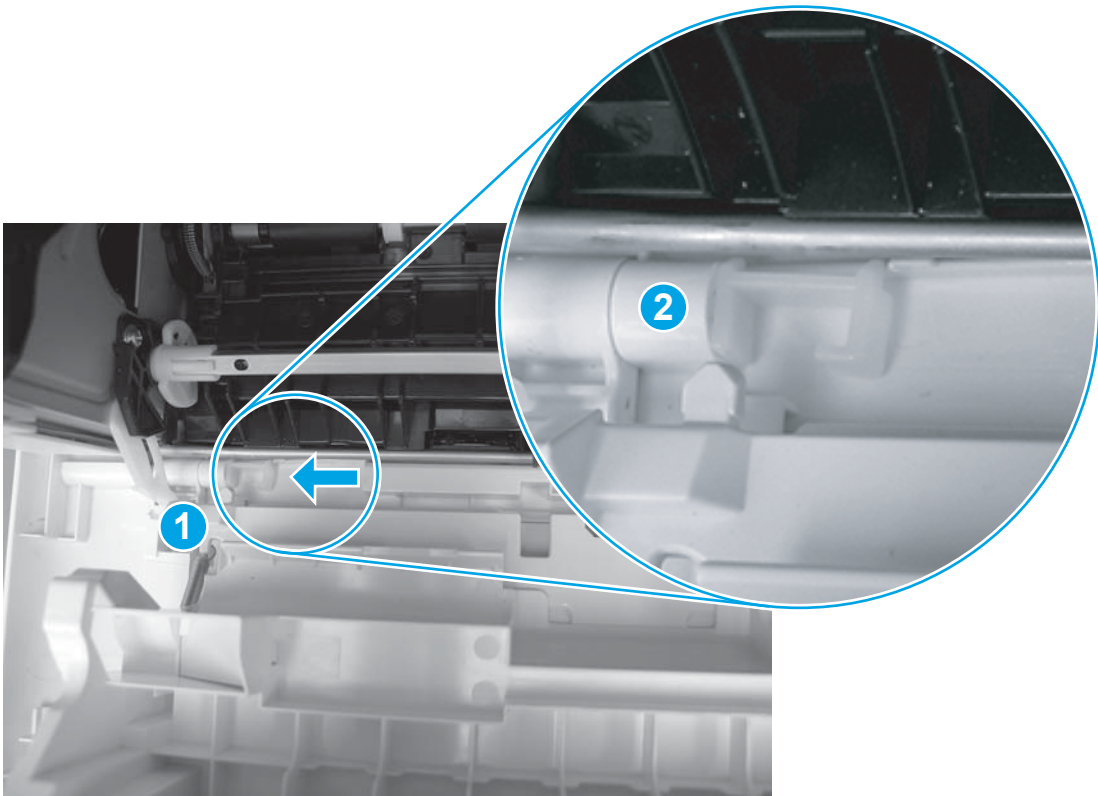
Figure 1-724 Install the tray



Removal and replacement: Main motor (M1)

- [Introduction](#)
- [Step 1: Remove Tray 2](#)
- [Step 2: Remove the cartridge door assembly](#)
- [Step 3: Remove the right cover](#)
- [Step 4: Remove the main motor \(M1\)](#)
- [Step 5: Unpack the replacement assembly](#)
- [Step 6: Install the main motor \(M1\)](#)
- [Step 7: Install the right cover](#)
- [Step 8: Install the cartridge door assembly](#)
- [Step 9: Install Tray 2](#)

Introduction

This document provides the procedures to remove and replace the main motor (M1).

Before performing service

Turn the printer power off

- Disconnect the power cable.

 **WARNING!** To avoid damage to the printer, turn the printer off, wait 30 seconds, and then remove the power cable before attempting to service the printer.

Use the table below to identify the correct part number for your printer. To order the part, go to www.hp.com/buy/parts.

Main motor (M1) part number	
RM2-8684-000CN	Main motor (M1)

Required tools

- #2 Phillips screwdriver with a magnetic tip.

After performing service

Turn the printer power on

- Connect the power cable.
- Use the power switch to turn the power on.

Post service test

Make sure that the printer initializes to a **Ready** state.

Print a configuration page to make sure that the printer is functioning correctly.

Step 1: Remove Tray 2

- ▲ Pull the tray straight out of the printer to remove it.

Figure 1-725 Remove the tray



Step 2: Remove the cartridge door assembly

 **NOTE:** If the toner cartridge was not removed prior to servicing the printer, remove it now.

1. Release one tab (callout 1), and then slide shaft (callout 2) in the direction the arrow indicates and remove it.

 **TIP:** It might be easier to release the support shaft by using a small flat-blade screwdriver.

Figure 1-726 Release the support shaft

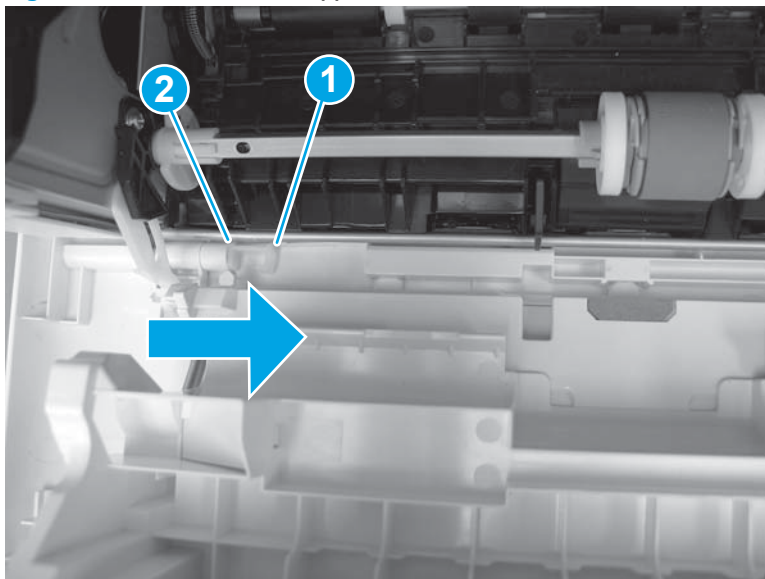

2. Release one tab (callout 1), and then slide the guide (callout 2) in the direction the arrow indicates and remove it.

Figure 1-727 Remove the guide

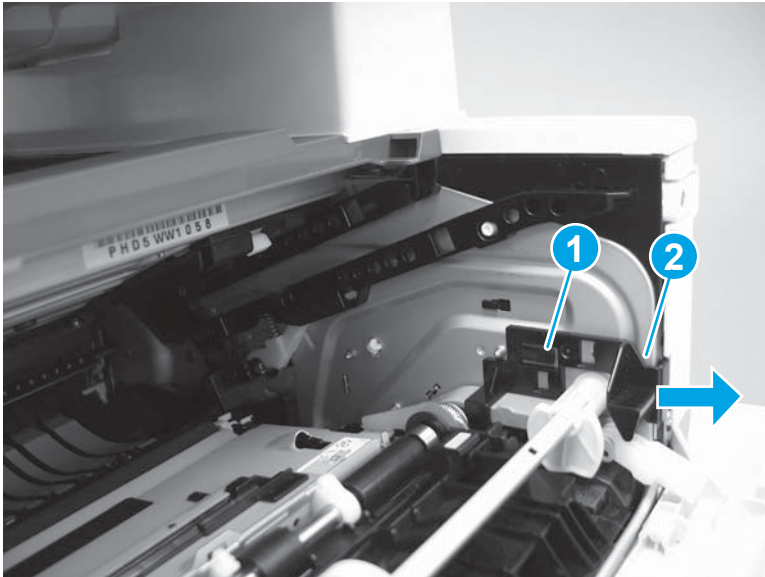

3. Remove the link arm (callout 1).

Figure 1-728 Remove the link arm

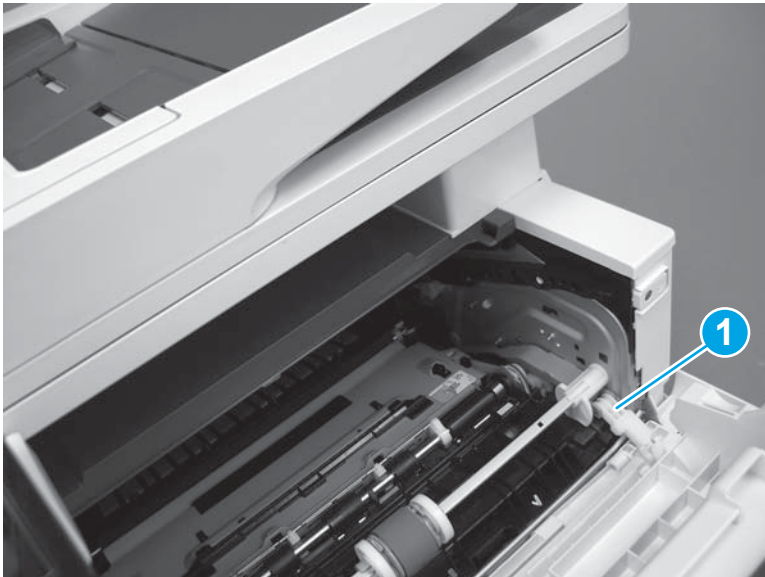

4. Slide the cartridge door assembly (callout 1) in the direction the arrow indicates and remove it.

Figure 1-729 Remove the door

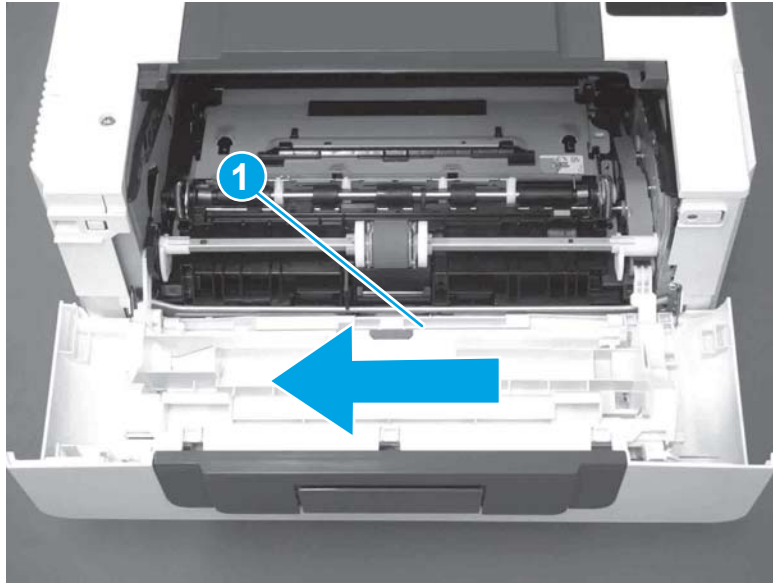

5. Remove the link (callout 1) from the cartridge door assembly (callout 2).

Figure 1-730 Release the left-side retainer arm

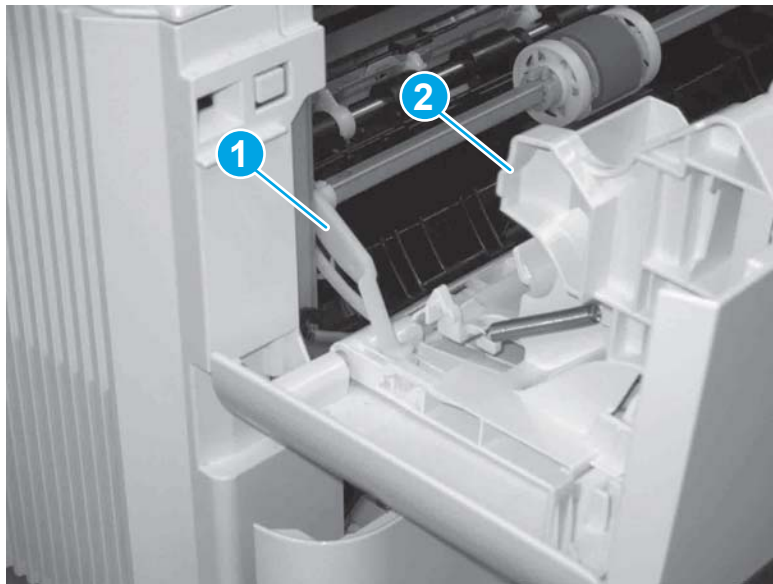

Step 3: Remove the right cover

1. Remove one screw (callout 1).

Figure 1-731 Remove one screw



2. At the front of the printer, release two bosses (callout 1), and then release three tabs (callout 2).

Figure 1-732 Release two bosses and three tabs

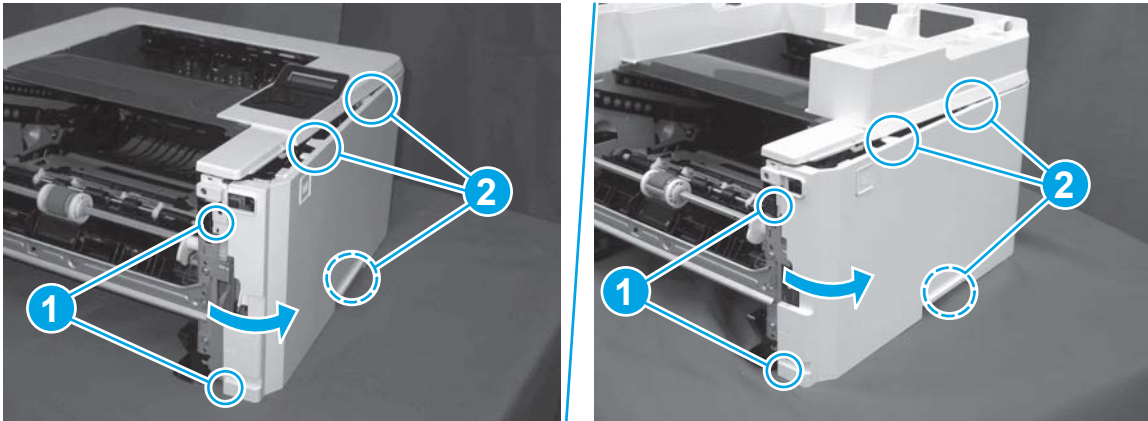

3. Open the rear door, release two bosses (callout 1), and then remove the cover (callout 2).

Figure 1-733 Remove the cover

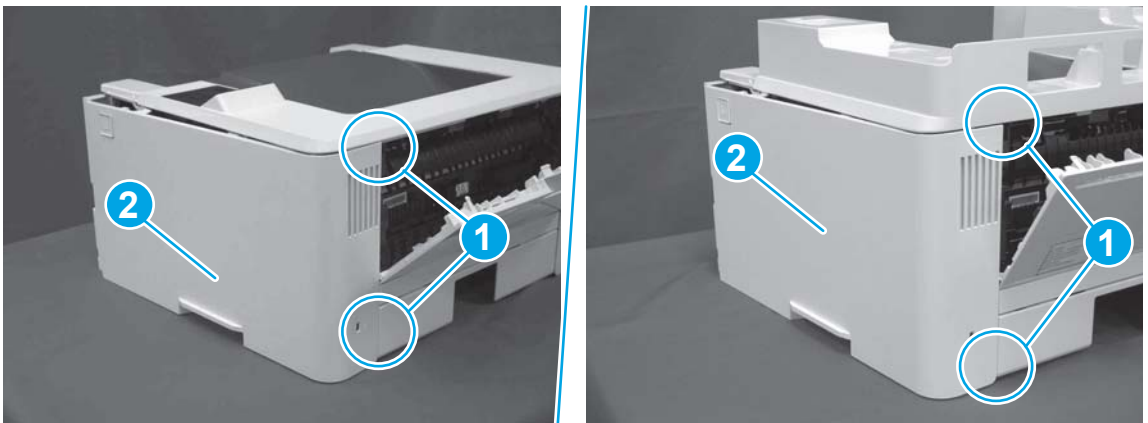

Step 4: Remove the main motor (M1)

- ▲ Disconnect one connector (callout 1), remove four screws (callout 2), and then remove the main motor (M1).

Figure 1-734 Remove the motor

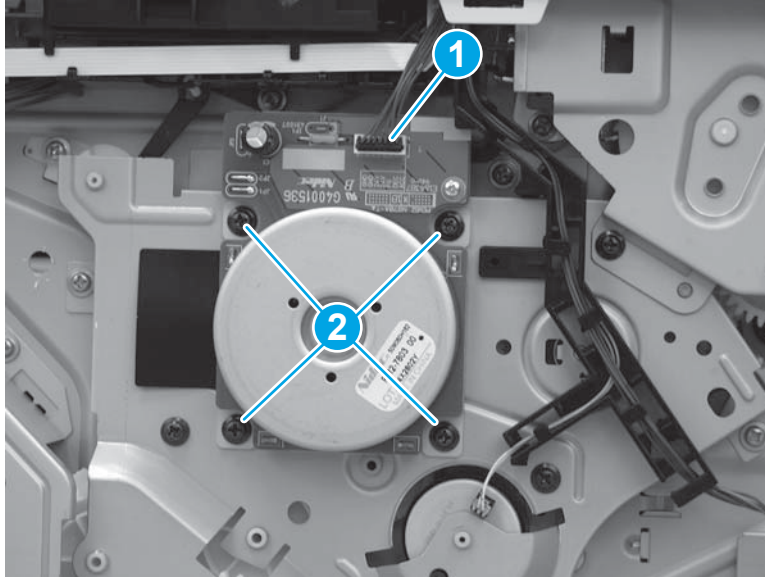

Step 5: Unpack the replacement assembly

Unpack the replacement part from the packaging.

<http://www8.hp.com/us/en/hp-information/environment/product-recycling.html>

 **NOTE:** HP recommends responsible disposal of the defective part.

Figure 1-735 Recycle and unpack

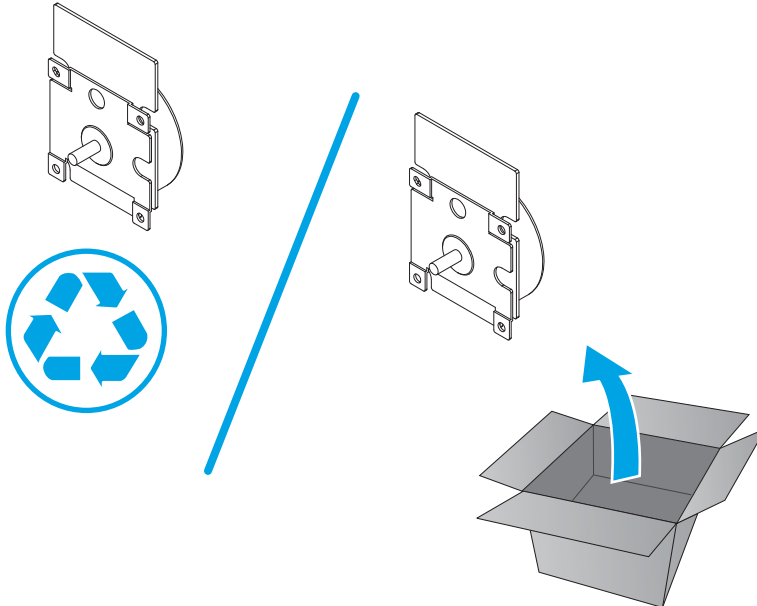

Step 6: Install the main motor (M1)

- ▲ Position the motor on the chassis, install four screws in the order shown below (callout 1 to callout 4), and then connect one connector (callout 5).

 **CAUTION:** Make sure that the screws are installed in the order shown below.

Figure 1-736 Install the motor

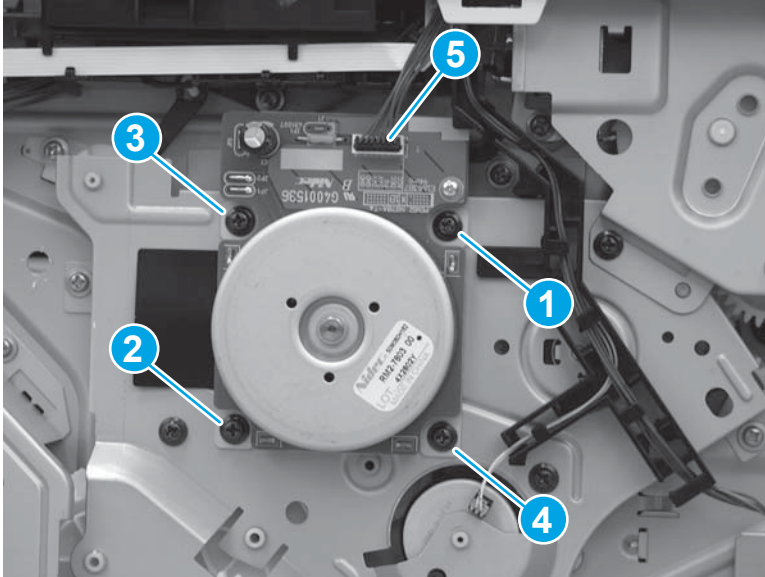

Step 7: Install the right cover

1. Position the cover (callout 1) on the printer, and then engage two bosses (callout 2).

Figure 1-737 Install the cover

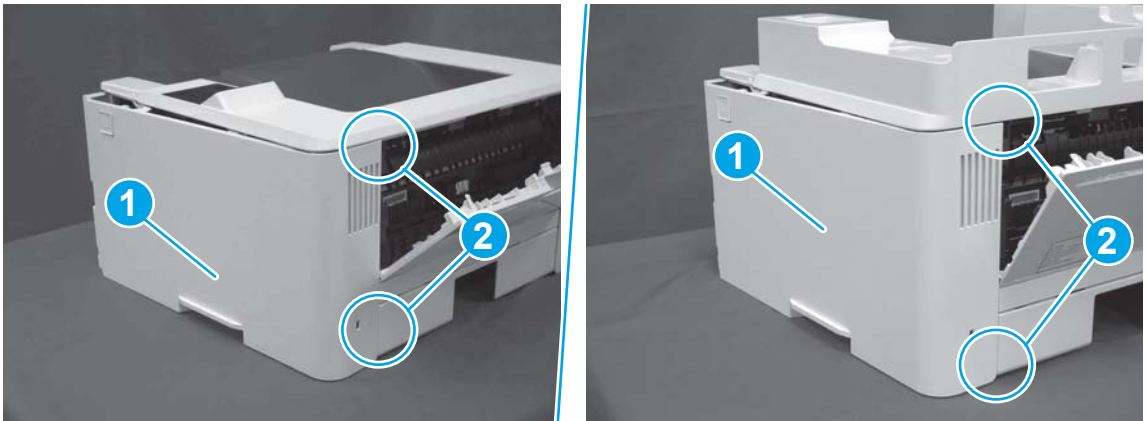

2. Rotate the front of the cover onto the printer (callout 1), engage three (callout 2) tabs, and then engage two bosses (callout 3).

Figure 1-738 Engage two bosses and one tab

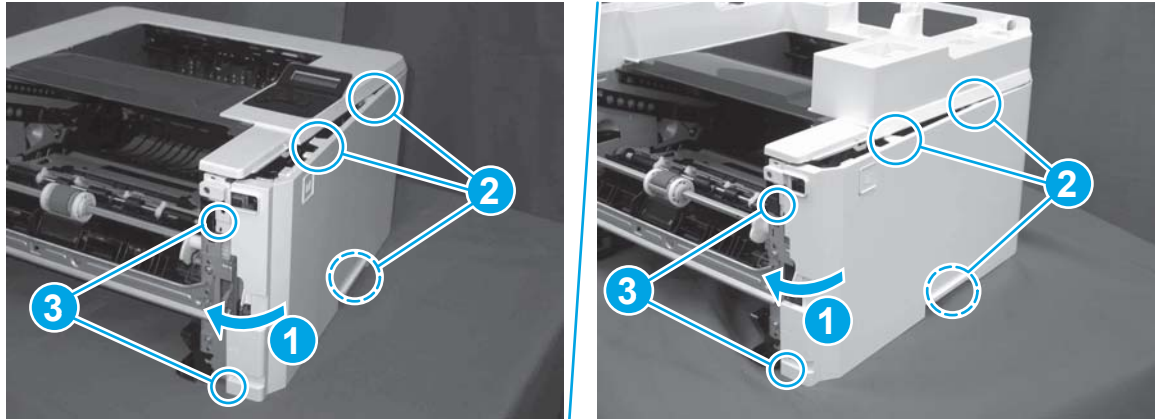

3. Make sure that the power switch (callout 1) and cartridge door assembly button (callout 2) correctly function.



NOTE: Remove, and then reinstall the cover if the switch or button does not correctly function.

Figure 1-739 Check the power switch and cartridge door assembly button

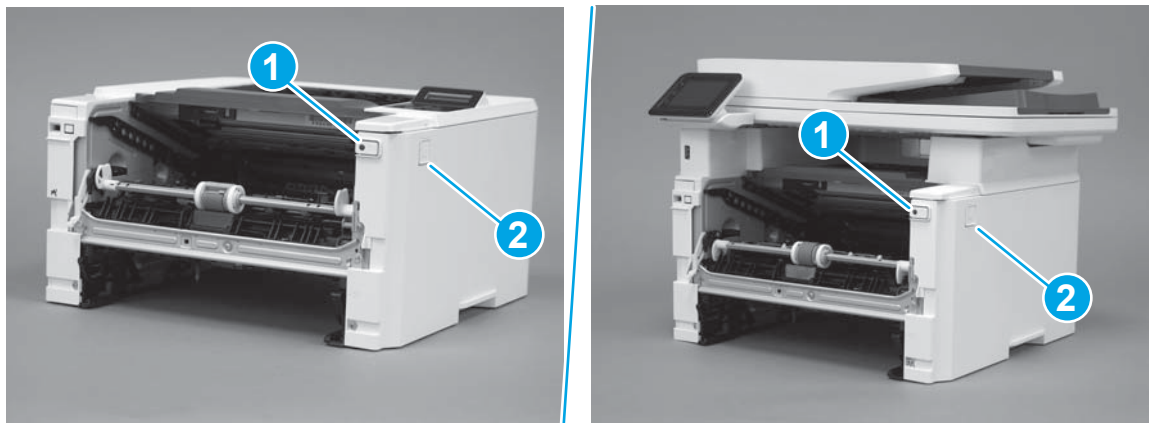

4. Install one screw (callout 1).

Figure 1-740 Install one screw



Step 8: Install the cartridge door assembly

 **Reinstallation tip:** After a replacement door is installed, make sure to install the nameplate (supplied in the kit) corresponding to the printer name on the door.

1. Position the door close to the printer, and then engage the keyed pin on the left-side retainer arm with the hole in the door.

Figure 1-741 Engage the left-side retainer arm

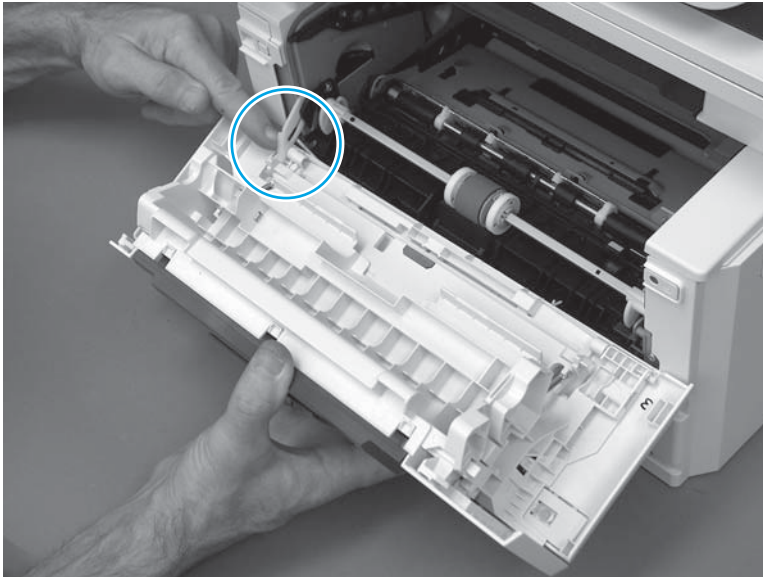

2. Engage the right-side door hinge pin with the hole in the chassis (callout 1).

Figure 1-742 Install the door

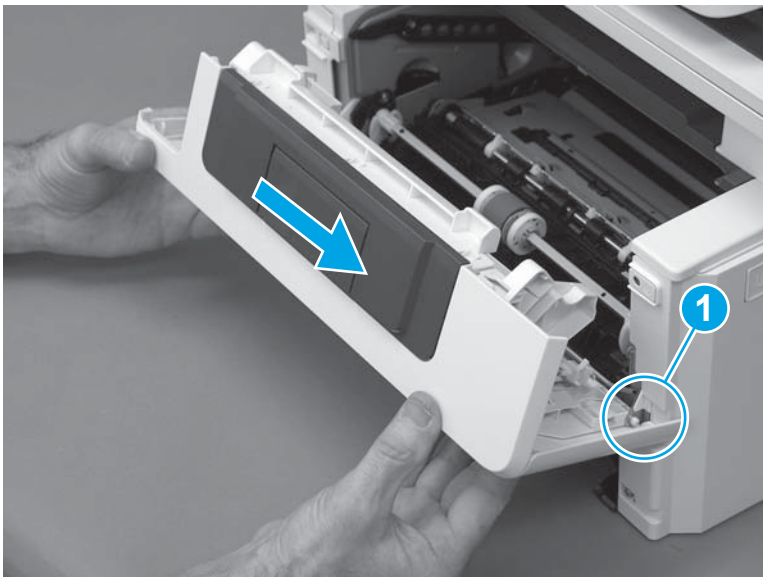

3. Install the link (callout 1).

 **IMPORTANT:** Make sure that the link snaps into place on the arm (callout 2). The link actuates the fuser pressure-release mechanism.

Figure 1-743 Install the pressure-release link

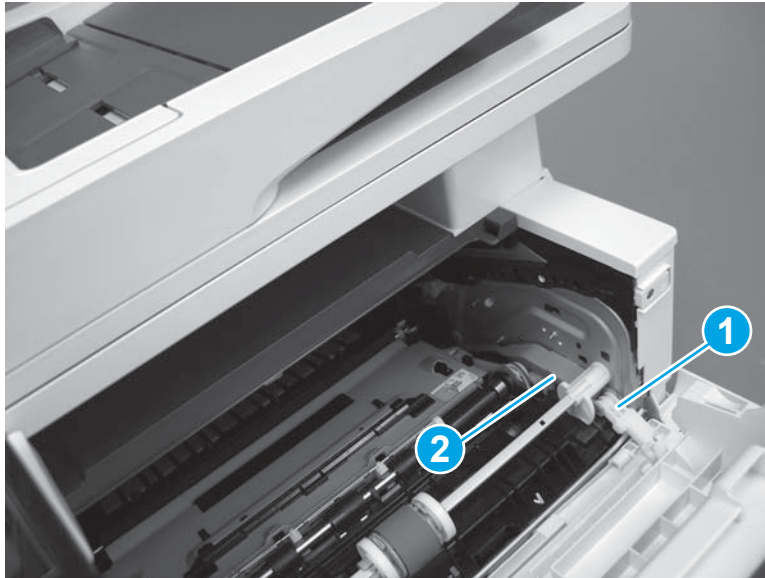

4. Slide the guide into the printer (callout 1), and then make sure that the tab (callout 2) snaps into place to secure the guide to the chassis.

Figure 1-744 Install the guide

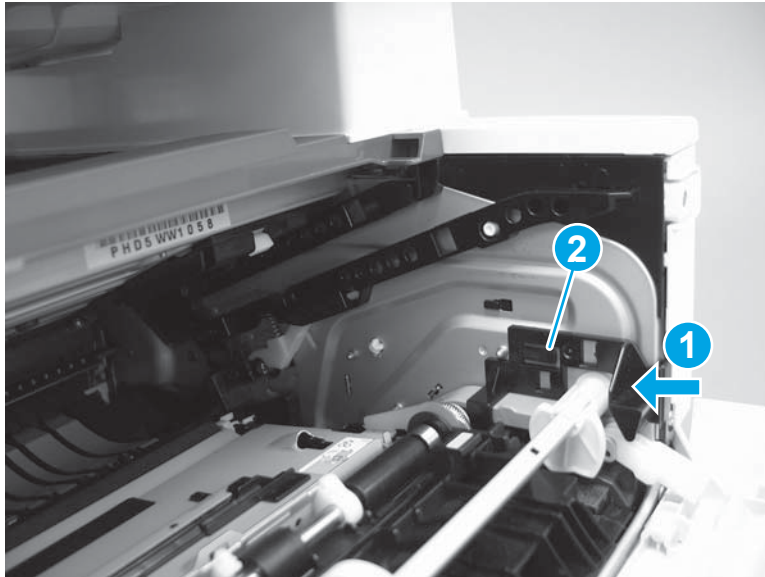

5. Position the shaft on the door, and then align the left-side hinge on the door with the hole in the chassis (callout 1).

Figure 1-745 Align the hinge

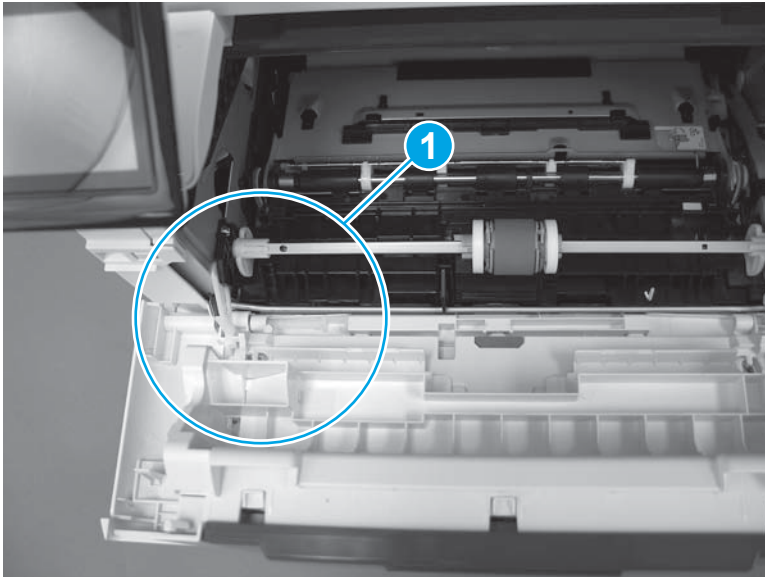

6. Push the shaft towards the left side of the printer to install it (callout 1).

 **Reinstallation tip:** Make sure that the support shaft is fully installed and correctly orientated (callout 2) so that it will not interfere with the door opening and closing.

Figure 1-746 Install the support shaft



Step 9: Install Tray 2

- ▲ Slide the tray straight into the printer to install it.

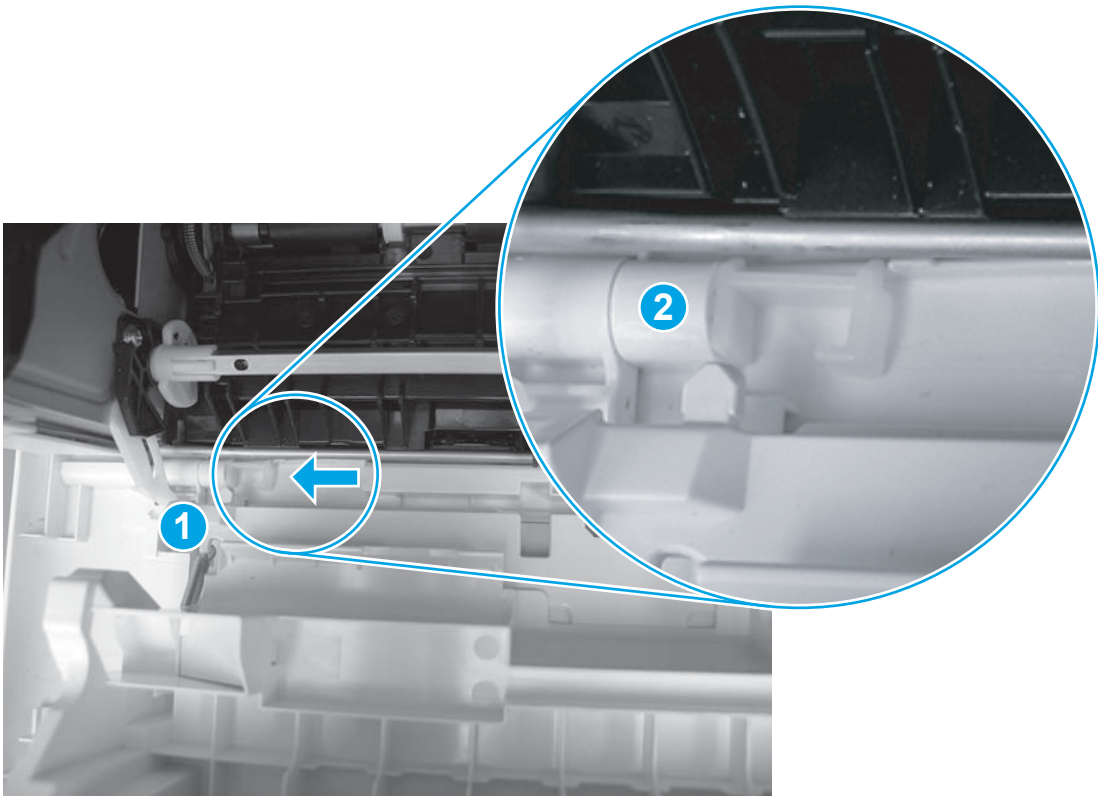
Figure 1-747 Install the tray



Removal and replacement: Power switch printed circuit assembly

- [Introduction](#)
- [Step 1: Remove Tray 2](#)
- [Step 2: Remove the cartridge door assembly](#)
- [Step 3: Remove the right cover](#)
- [Step 4: Remove the power switch PCA](#)
- [Step 5: Unpack the replacement assembly](#)
- [Step 6: Install the power switch PCA](#)
- [Step 7: Install the right cover](#)
- [Step 8: Install the cartridge door assembly](#)
- [Step 9: Install Tray 2](#)

Introduction

This document provides the procedures to remove and replace the power switch printed circuit assembly (PCA).

Before performing service

Turn the printer power off

- Disconnect the power cable.

 **WARNING!** To avoid damage to the printer, turn the printer off, wait 30 seconds, and then remove the power cable before attempting to service the printer.

Use the table below to identify the correct part number for your printer. To order the part, go to www.hp.com/buy/parts.

Power switch PCA part number	
RM2-8506-000CN	Power switch PCA

Required tools

- #2 Phillips screwdriver with a magnetic tip.

After performing service

Turn the printer power on

- Connect the power cable.
- Use the power switch to turn the power on.

Post service test

Use the power switch to turn the printer on, and then off.

Step 1: Remove Tray 2

- ▲ Pull the tray straight out of the printer to remove it.

Figure 1-748 Remove the tray



Step 2: Remove the cartridge door assembly

 **NOTE:** If the toner cartridge was not removed prior to servicing the printer, remove it now.

1. Release one tab (callout 1), and then slide shaft (callout 2) in the direction the arrow indicates and remove it.

 **TIP:** It might be easier to release the support shaft by using a small flat-blade screwdriver.

Figure 1-749 Release the support shaft

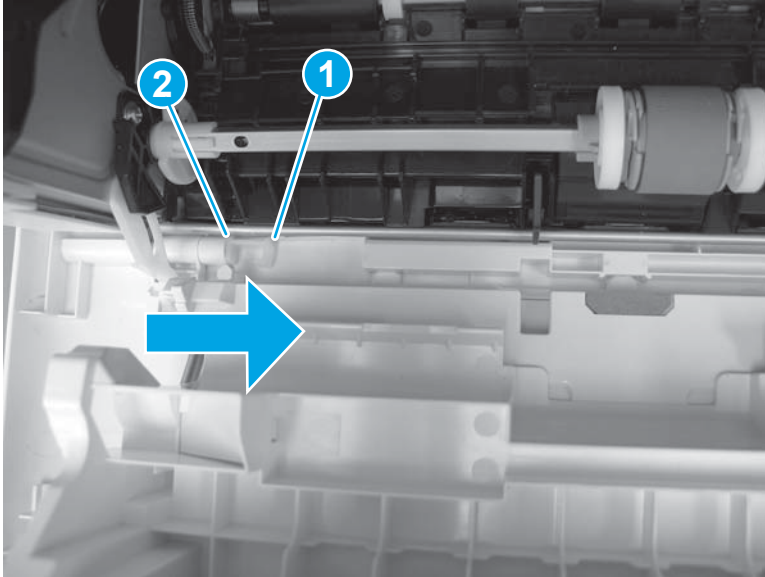

2. Release one tab (callout 1), and then slide the guide (callout 2) in the direction the arrow indicates and remove it.

Figure 1-750 Remove the guide

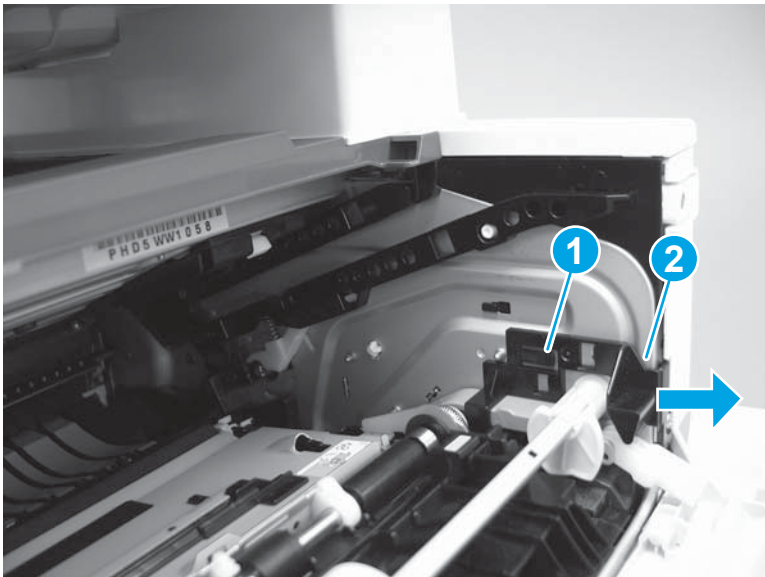

3. Remove the link arm (callout 1).

Figure 1-751 Remove the link arm

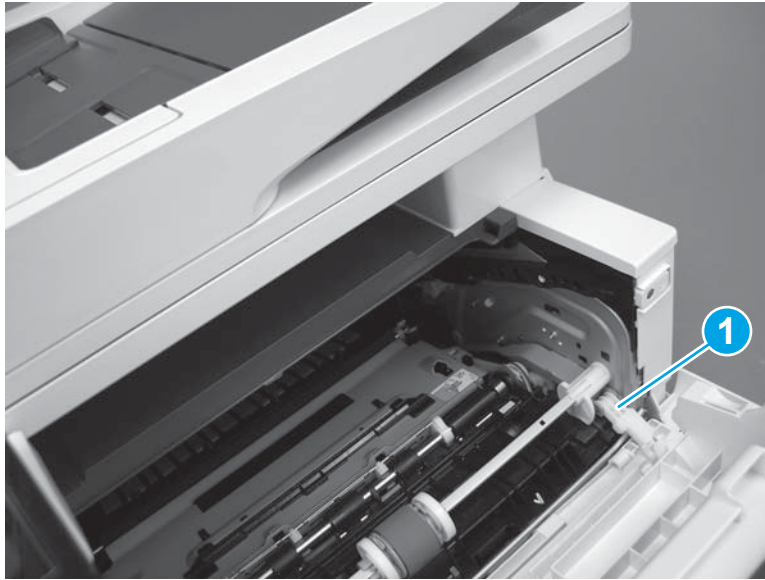

4. Slide the cartridge door assembly (callout 1) in the direction the arrow indicates and remove it.

Figure 1-752 Remove the door

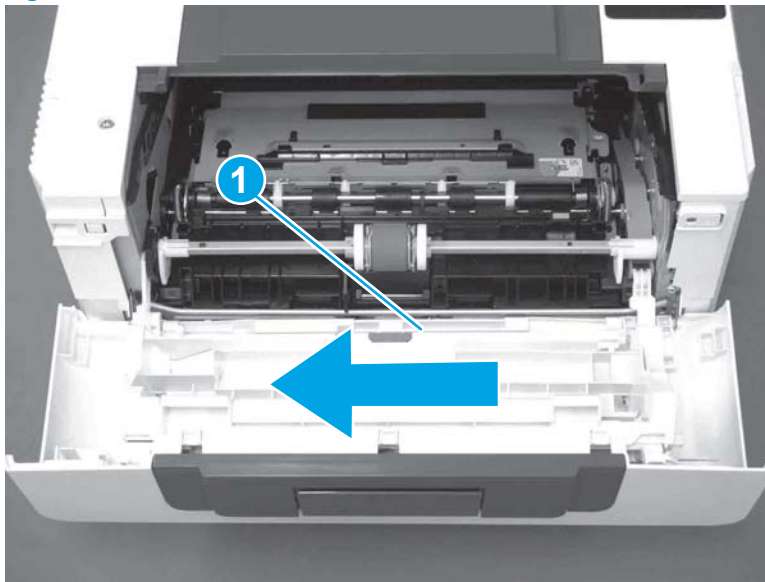

5. Remove the link (callout 1) from the cartridge door assembly (callout 2).

Figure 1-753 Release the left-side retainer arm

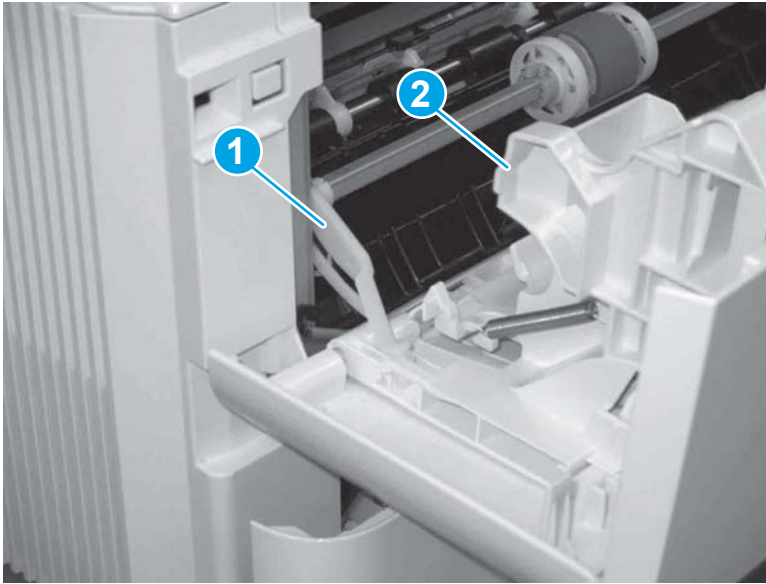

Step 3: Remove the right cover

1. Remove one screw (callout 1).

Figure 1-754 Remove one screw

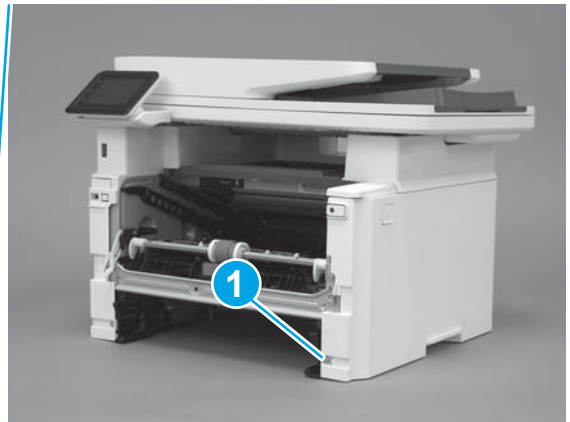
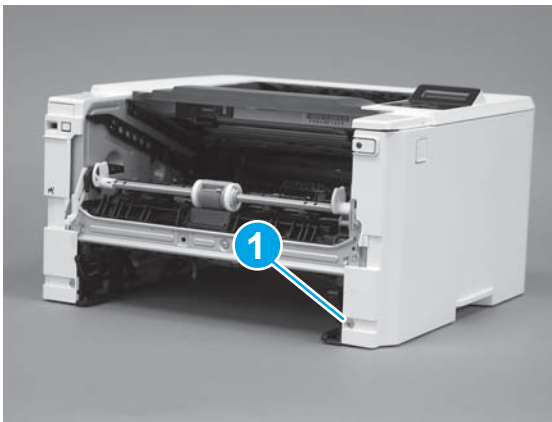

2. At the front of the printer, release two bosses (callout 1), and then release three tabs (callout 2).

Figure 1-755 Release two bosses and three tabs

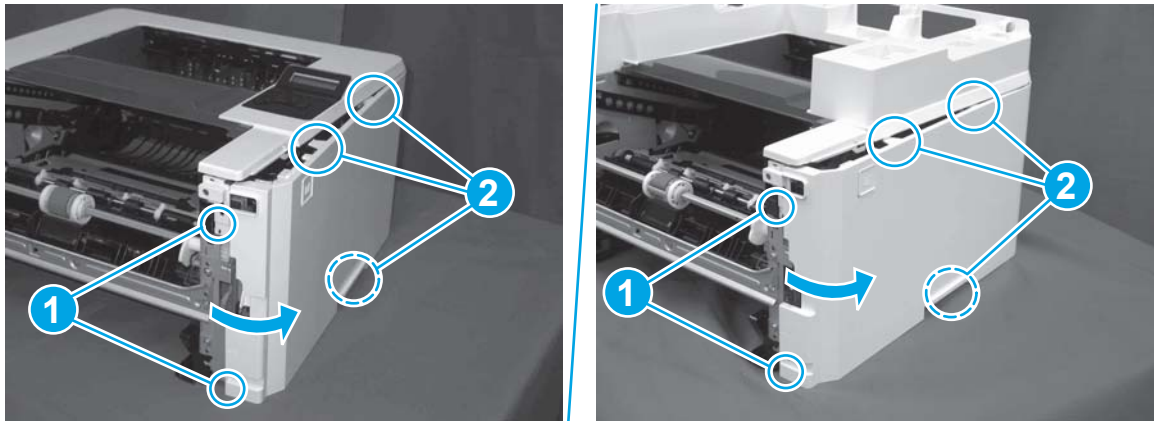

3. Open the rear door, release two bosses (callout 1), and then remove the cover (callout 2).

Figure 1-756 Remove the cover

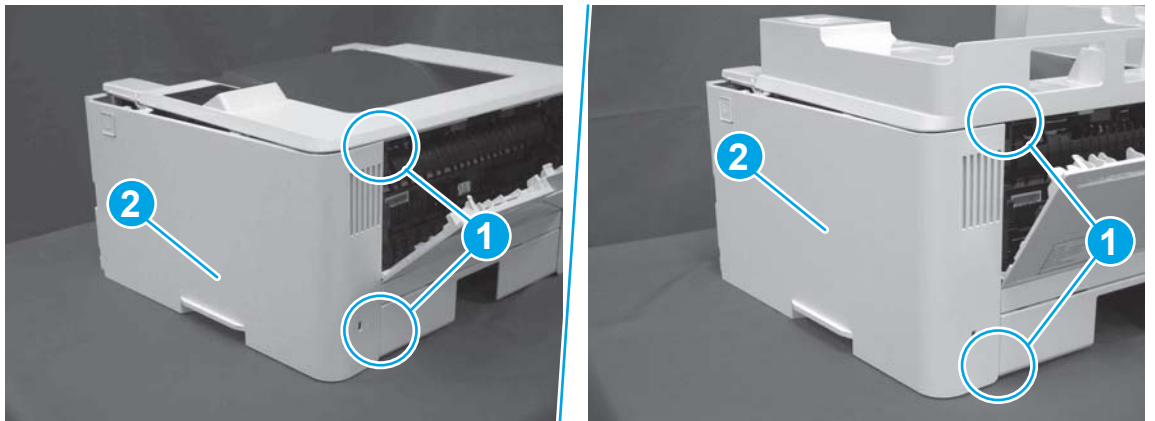

Step 4: Remove the power switch PCA

1. Release one tab (callout 1).

Figure 1-757 Release one tab

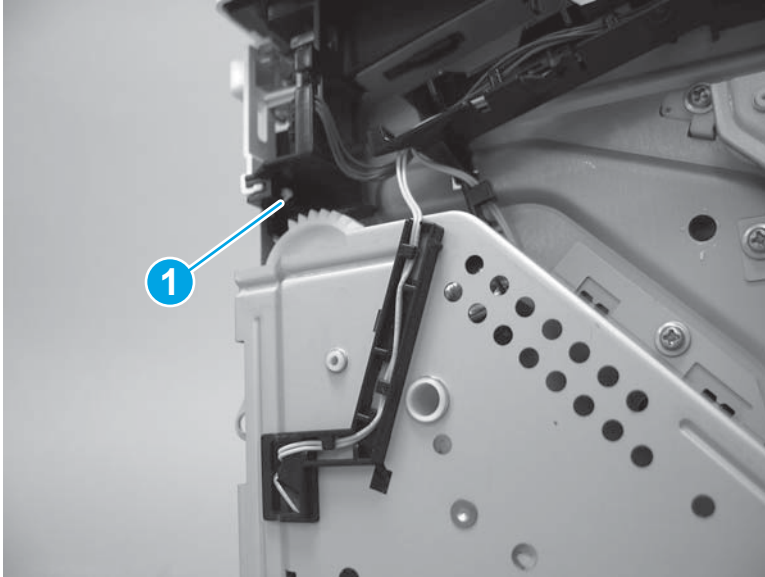

2. Remove the switch lever.

Figure 1-758 Remove the switch lever

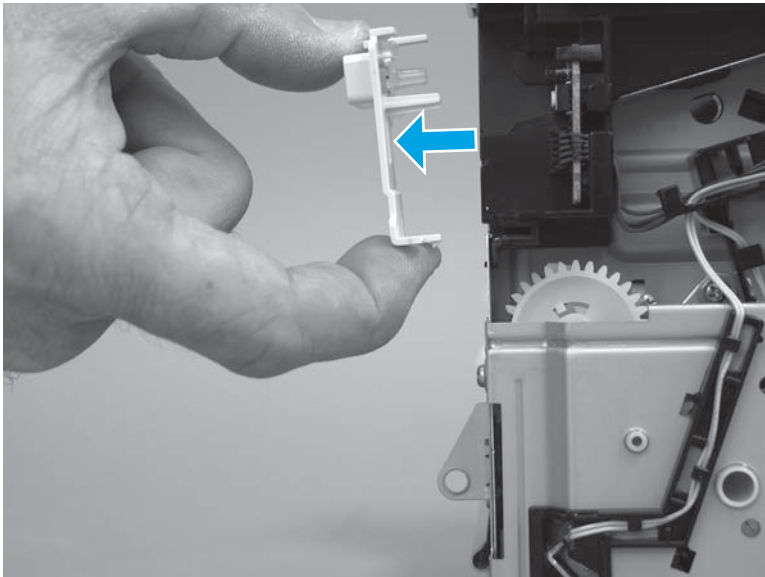

3. Release the wire harness from the guide (callout 1), and then disconnect one connector (callout 2).

Figure 1-759 Disconnect one connector

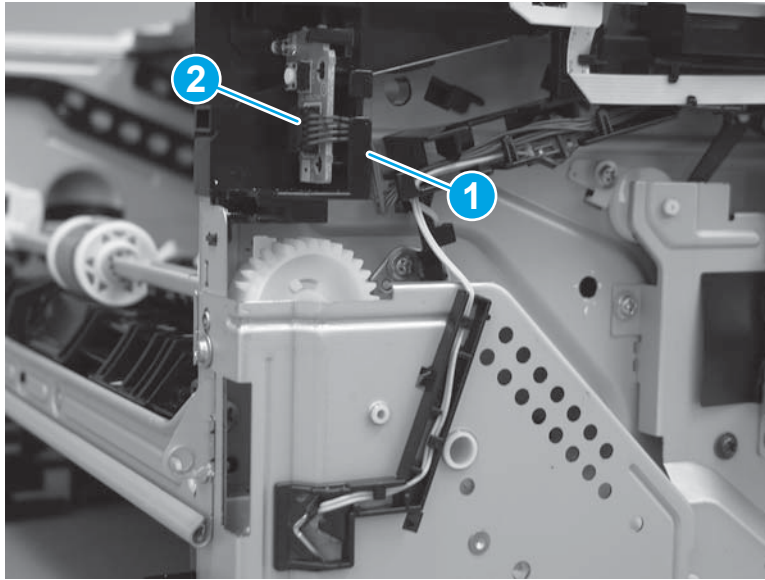

4. Release one tab (callout 1), and then remove the power switch PCA.

CAUTION: Do not damage the tab (callout 1) when releasing it. The tab must snap over the PCA when it is reinstalled.

Figure 1-760 Release one tab and remove the PCA

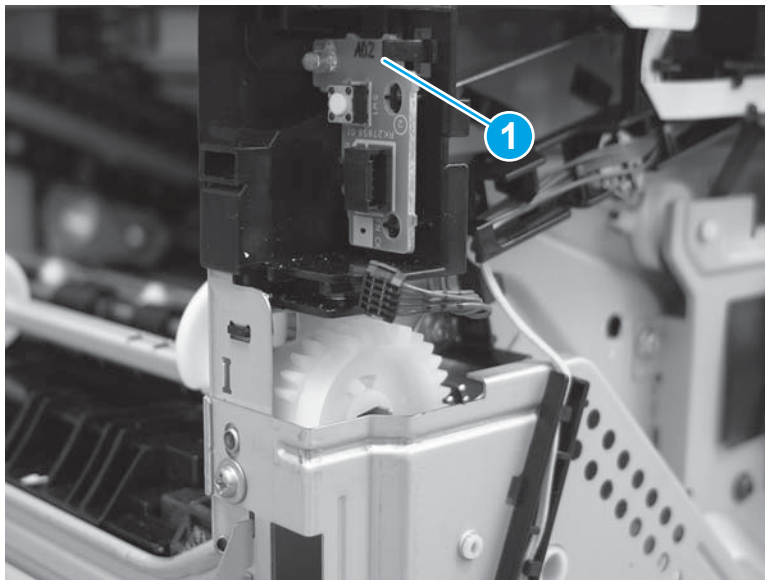

Step 5: Unpack the replacement assembly

Unpack the replacement part from the packaging.

<http://www8.hp.com/us/en/hp-information/environment/product-recycling.html>

NOTE: HP recommends responsible disposal of the defective part.

Figure 1-761 Recycle and unpack

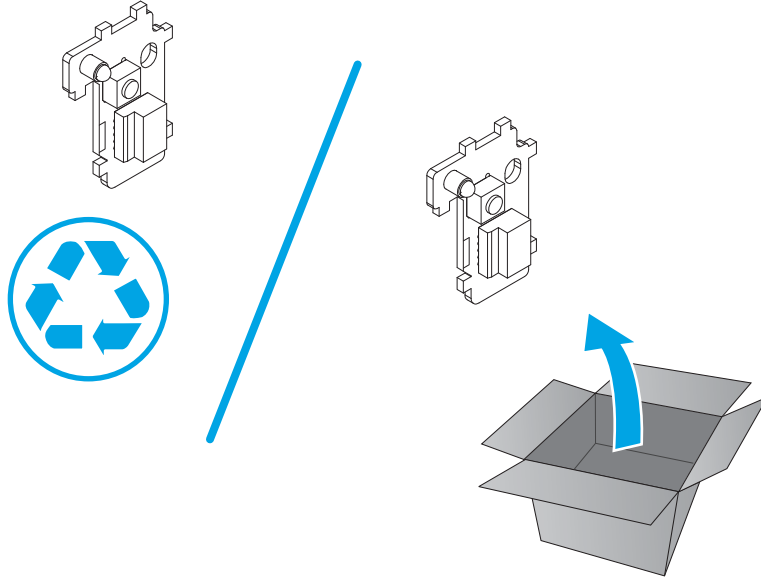

Step 6: Install the power switch PCA

1. Position the PCA in the holder. The PCA must be securely installed in the holder.

 **IMPORTANT:** Make sure of the following:

- The inside edge of the PCA is positioned behind the holder (callout 1).
- The two alignment pins are installed in the holes in the PCA (callout 2).
- The tab on the holder snaps in place over the edge of the PCA (callout 3).

Figure 1-762 Install the PCA

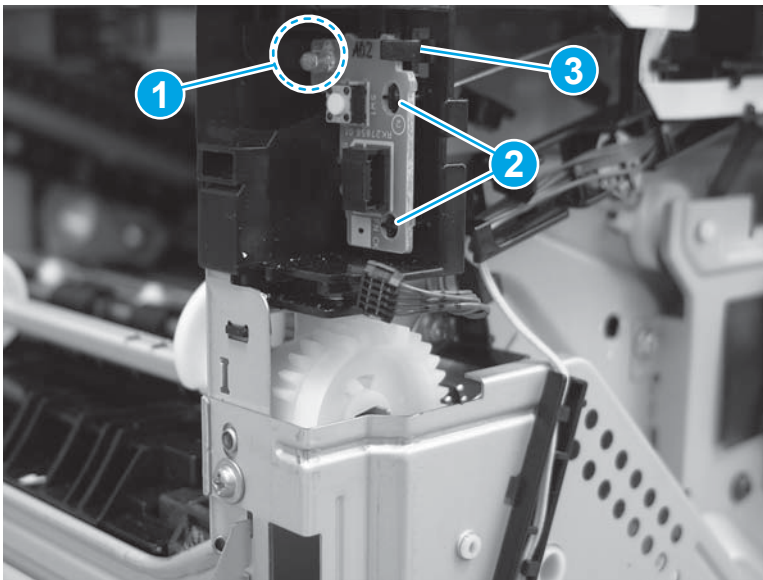

2. Connect one connector (callout 1), and then install the wire harness in the guide (callout 2).

Figure 1-763 Connect one connector and install the wire harness in the guide

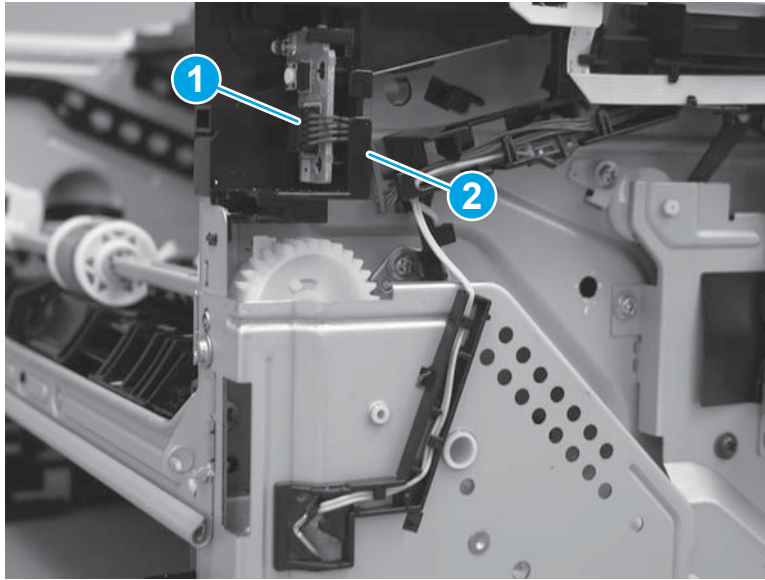

3. Install the switch lever.

Make sure that the switch lever freely moves in and out when pushed, and that it makes proper contact with the monetary switch on the power switch PCA.

Figure 1-764 Install the switch lever

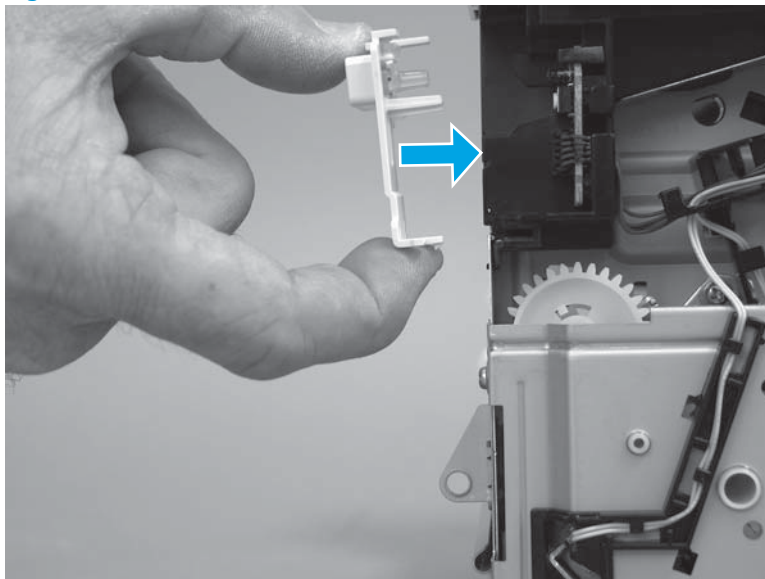

Step 7: Install the right cover

1. Position the cover (callout 1) on the printer, and then engage two bosses (callout 2).

Figure 1-765 Install the cover

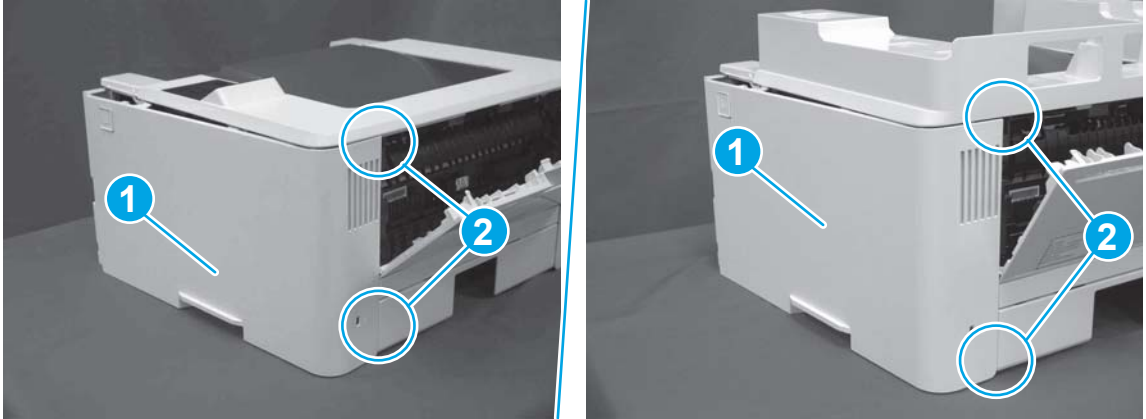

2. Rotate the front of the cover onto the printer (callout 1), engage three (callout 2) tabs, and then engage two bosses (callout 3).

Figure 1-766 Engage two bosses and one tab

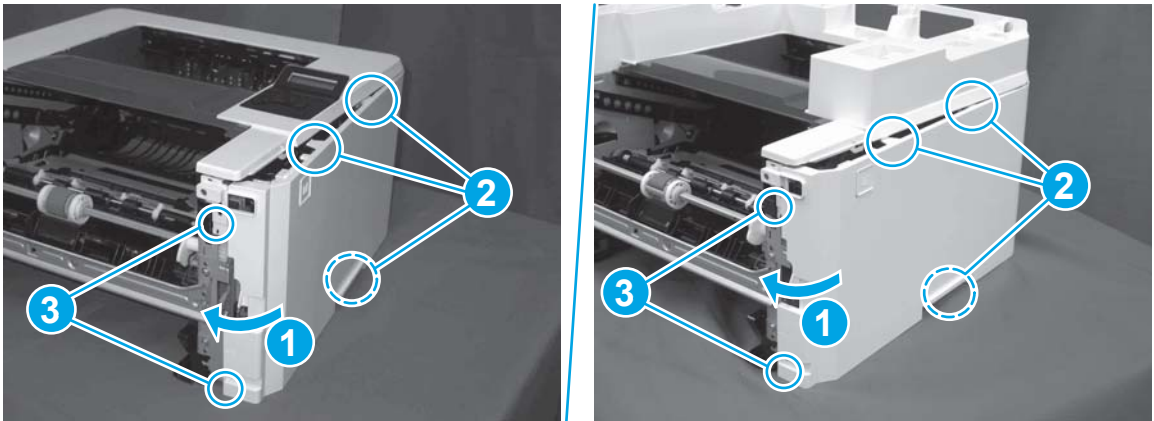

3. Make sure that the power switch (callout 1) and cartridge door assembly button (callout 2) correctly function.

 **NOTE:** Remove, and then reinstall the cover if the switch or button does not correctly function.

Figure 1-767 Check the power switch and cartridge door assembly button



4. Install one screw (callout 1).

Figure 1-768 Install one screw

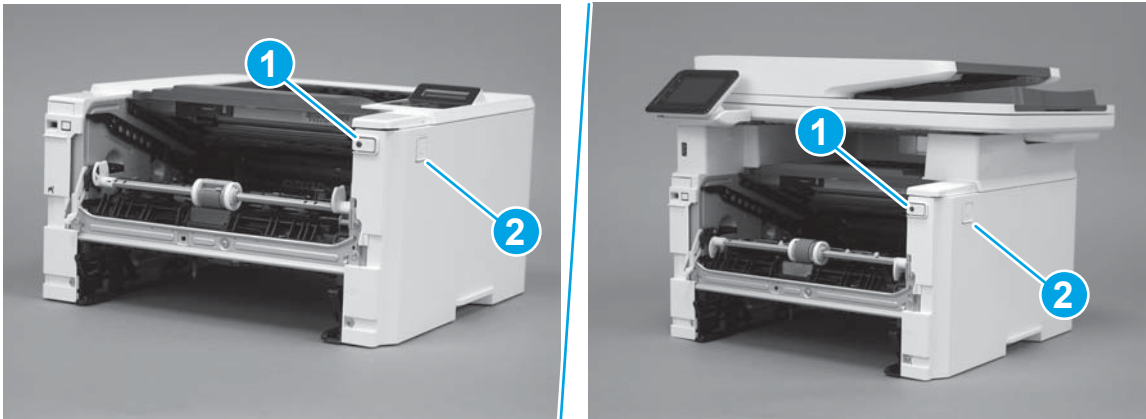

Step 8: Install the cartridge door assembly

 **Reinstallation tip:** After a replacement door is installed, make sure to install the nameplate (supplied in the kit) corresponding to the printer name on the door.

1. Position the door close to the printer, and then engage the keyed pin on the left-side retainer arm with the hole in the door.

Figure 1-769 Engage the left-side retainer arm

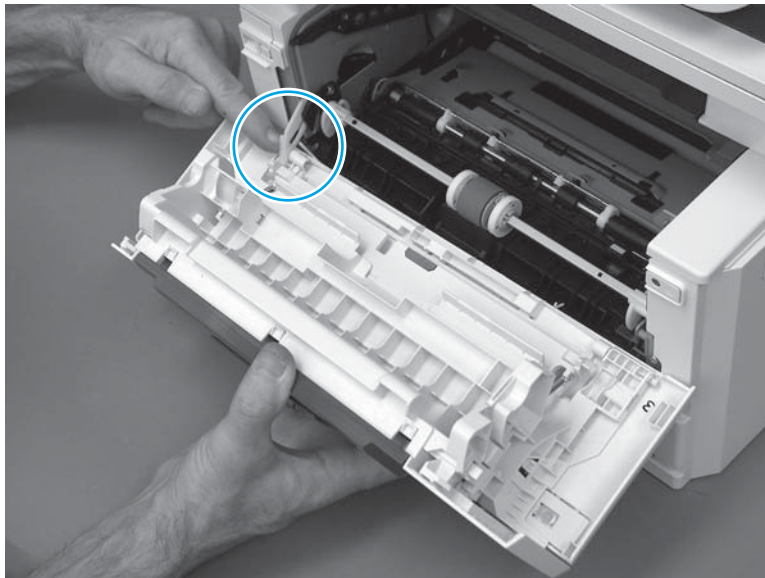

2. Engage the right-side door hinge pin with the hole in the chassis (callout 1).

Figure 1-770 Install the door

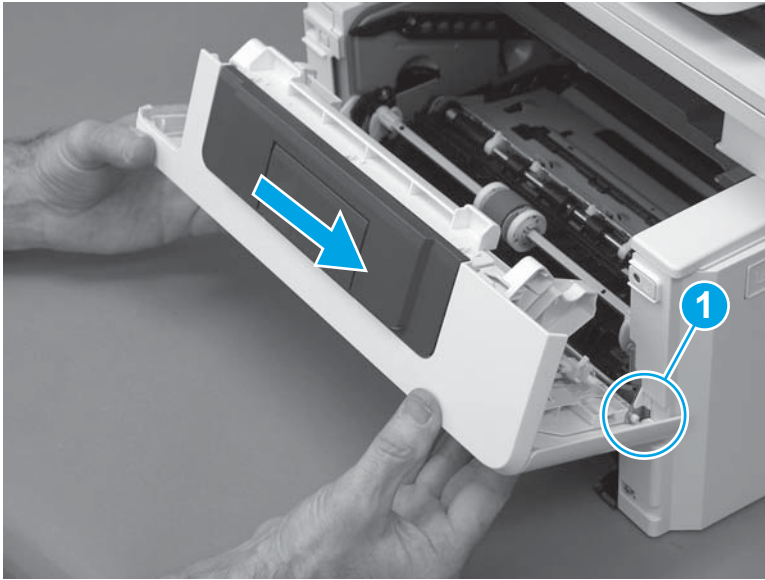

3. Install the link (callout 1).

 **IMPORTANT:** Make sure that the link snaps into place on the arm (callout 2). The link actuates the fuser pressure-release mechanism.

Figure 1-771 Install the pressure-release link

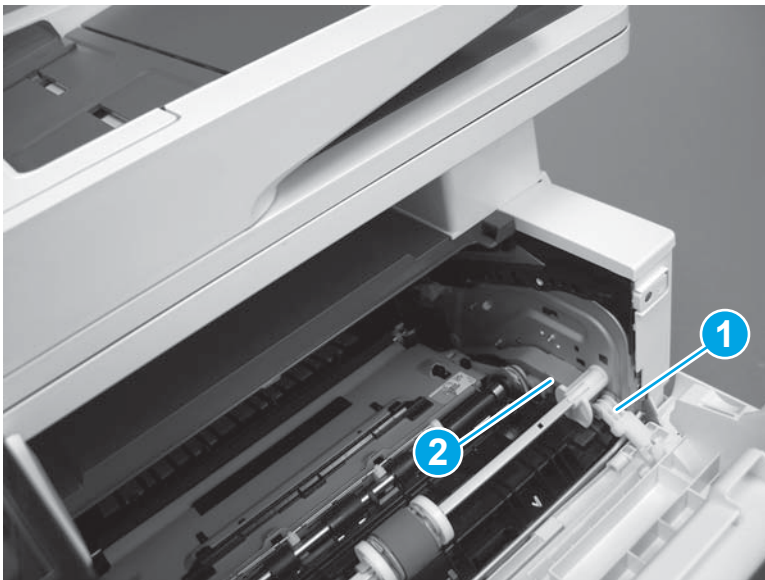

4. Slide the guide into the printer (callout 1), and then make sure that the tab (callout 2) snaps into place to secure the guide to the chassis.

Figure 1-772 Install the guide

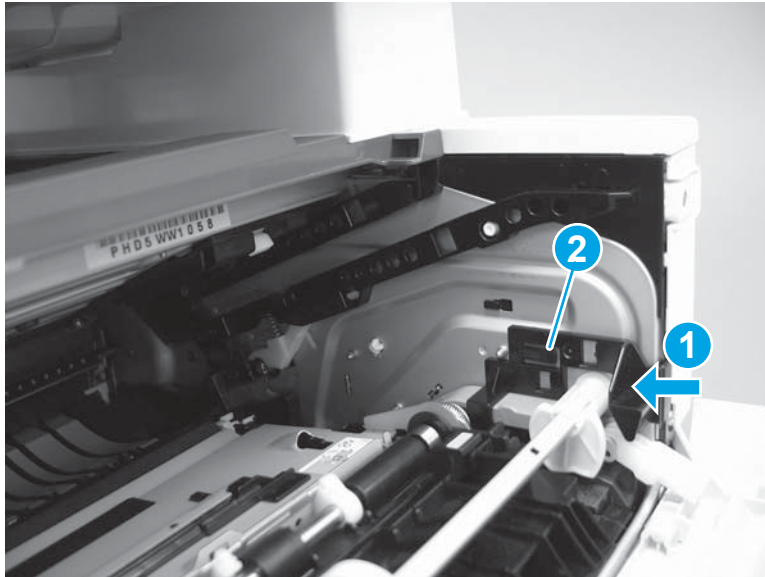

5. Position the shaft on the door, and then align the left-side hinge on the door with the hole in the chassis (callout 1).

Figure 1-773 Align the hinge

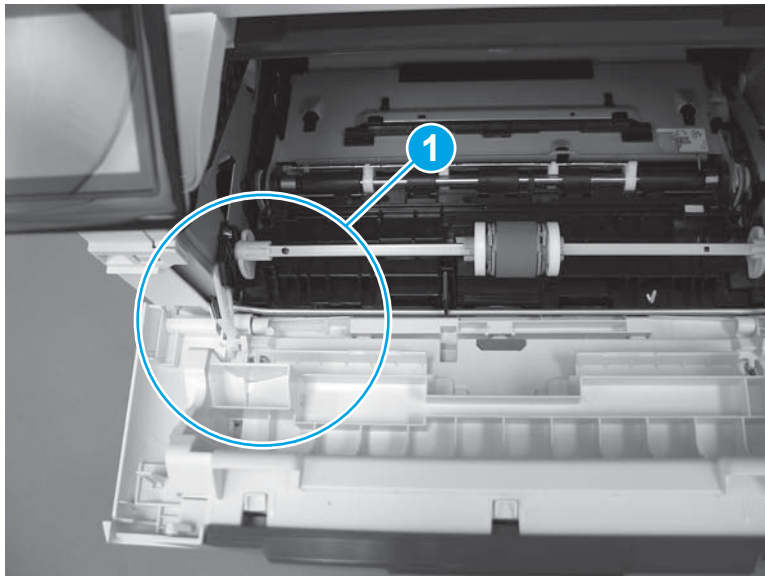

6. Push the shaft towards the left side of the printer to install it (callout 1).

 **Reinstallation tip:** Make sure that the support shaft is fully installed and correctly orientated (callout 2) so that it will not interfere with the door opening and closing.

Figure 1-774 Install the support shaft



Step 9: Install Tray 2

- ▲ Slide the tray straight into the printer to install it.

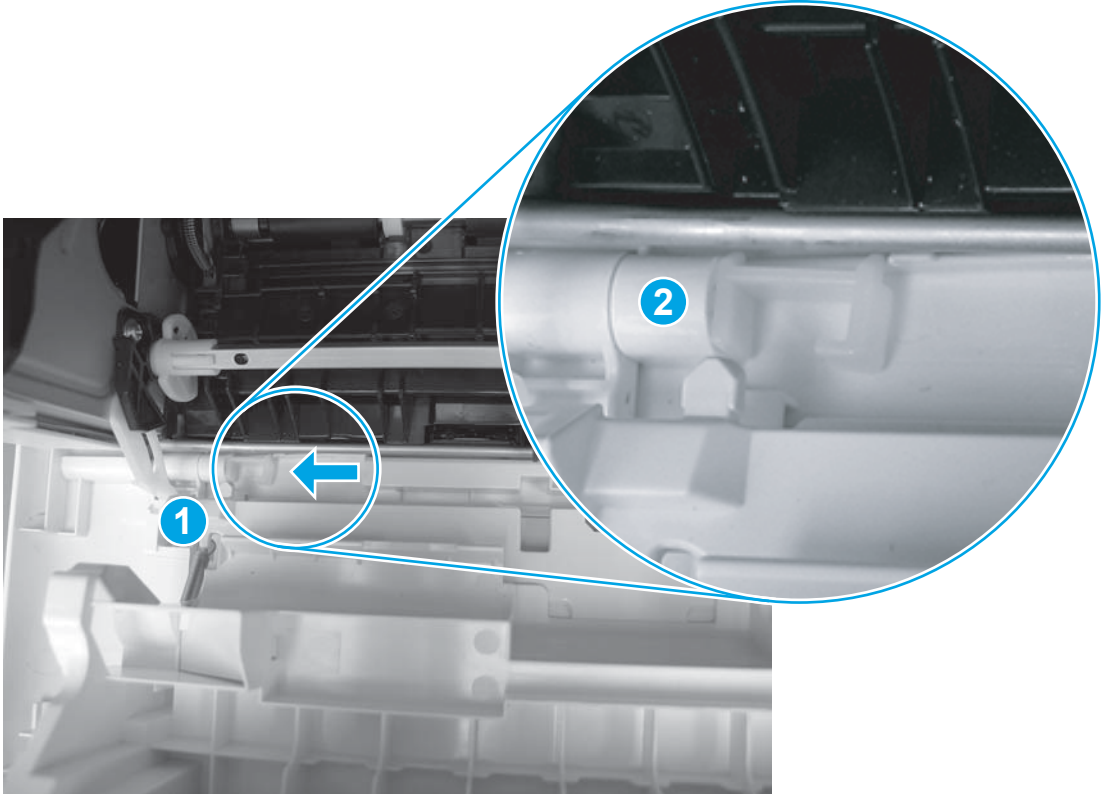
Figure 1-775 Install the tray



Removal and replacement: Fax PCA (M427/M426)



NOTE: Fax models only.

- [Introduction](#)
- [Step 1: Remove Tray 2](#)
- [Step 2: Remove the cartridge door assembly](#)
- [Step 3: Remove the left cover](#)
- [Step 4: Remove the fax PCA \(M427/M426\)](#)
- [Step 5: Unpack the replacement assembly](#)
- [Step 6: Install the fax PCA \(M427/M426\)](#)
- [Step 7: Install the left cover](#)
- [Step 8: Install the cartridge door assembly](#)
- [Step 9: Install Tray 2](#)

Introduction

This document provides the procedures to remove and replace the fax printed circuit assembly (PCA).

Before performing service

Turn the printer power off

- Disconnect the power cable.



WARNING! To avoid damage to the printer, turn the printer off, wait 30 seconds, and then remove the power cable before attempting to service the printer.

Use the table below to identify the correct part number for your printer. To order the part, go to www.hp.com/buy/parts.

Fax PCA part number	
CF206-60001	Fax PCA ¹ US/AP
CF207-60001	Fax PCA ¹ Euro
CF208-60001	Fax PCA ¹ Brazil

¹ M427/M426 fax models only.

Required tools

- #2 Phillips screwdriver with a magnetic tip.
- Small flat-blade screw driver

After performing service

Turn the printer power on

- Connect the power cable.
- Use the power switch to turn the power on.

Post service test

Make sure that the printer initializes to a **Ready** state.

If possible, send a fax to the printer.

Step 1: Remove Tray 2

- ▲ Pull the tray straight out of the printer to remove it.

Figure 1-776 Remove the tray



Step 2: Remove the cartridge door assembly

 **NOTE:** If the toner cartridge was not removed prior to servicing the printer, remove it now.

1. Release one tab (callout 1), and then slide shaft (callout 2) in the direction the arrow indicates and remove it.

 **TIP:** It might be easier to release the support shaft by using a small flat-blade screwdriver.

Figure 1-777 Release the support shaft

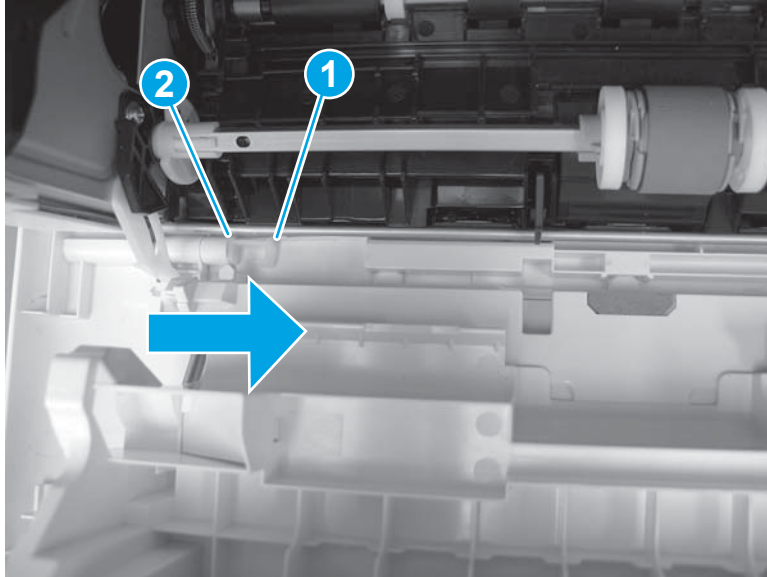

2. Release one tab (callout 1), and then slide the guide (callout 2) in the direction the arrow indicates and remove it.

Figure 1-778 Remove the guide

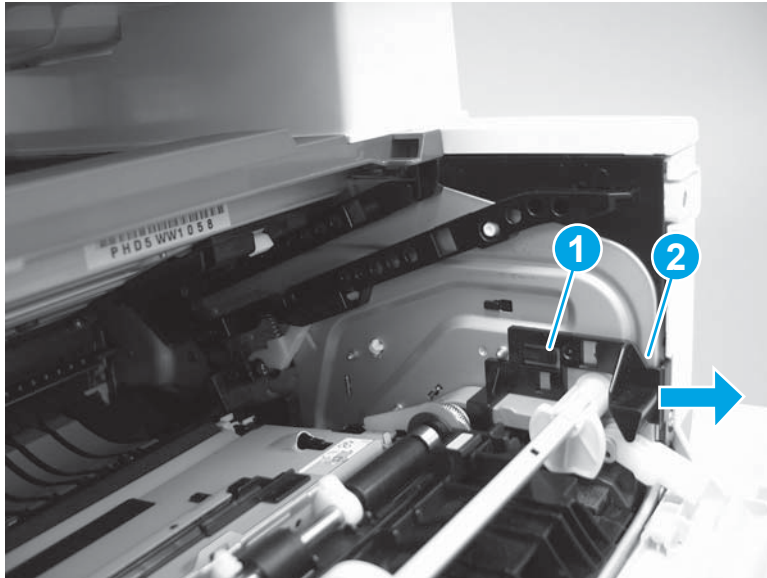

3. Remove the link arm (callout 1).

Figure 1-779 Remove the link arm

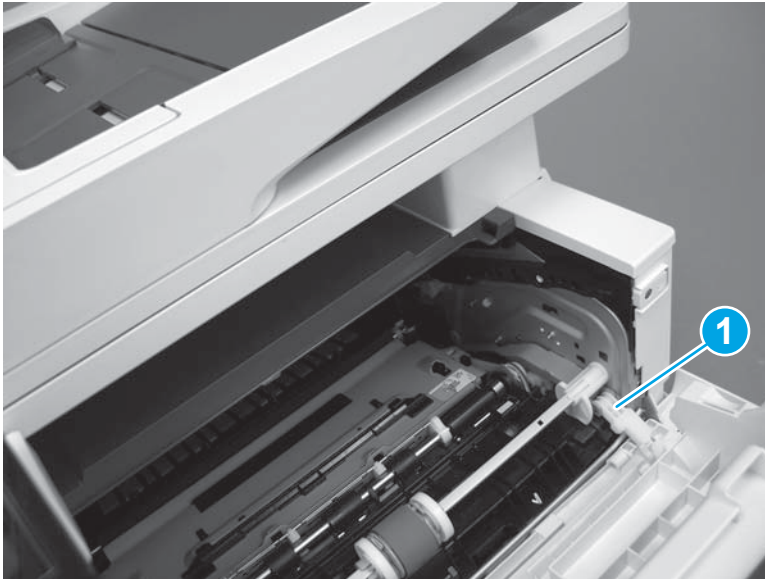

4. Slide the cartridge door assembly (callout 1) in the direction the arrow indicates and remove it.

Figure 1-780 Remove the door

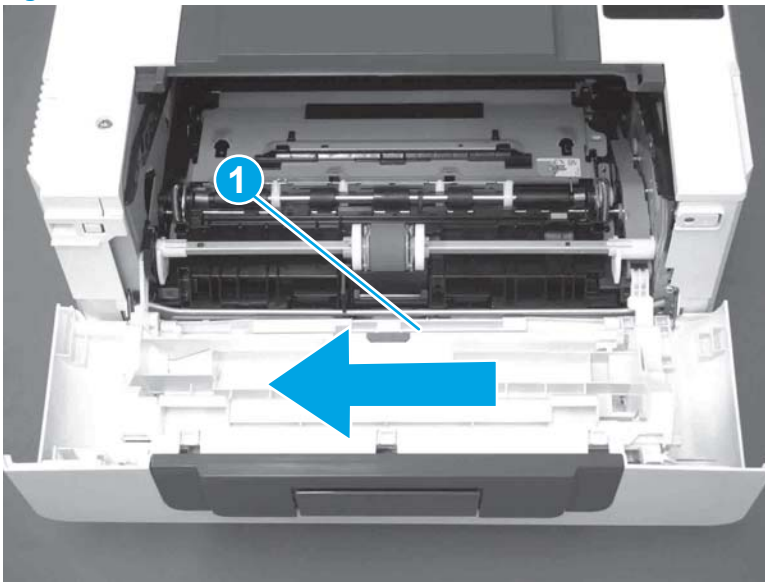

5. Remove the link (callout 1) from the cartridge door assembly (callout 2).

Figure 1-781 Release the left-side retainer arm

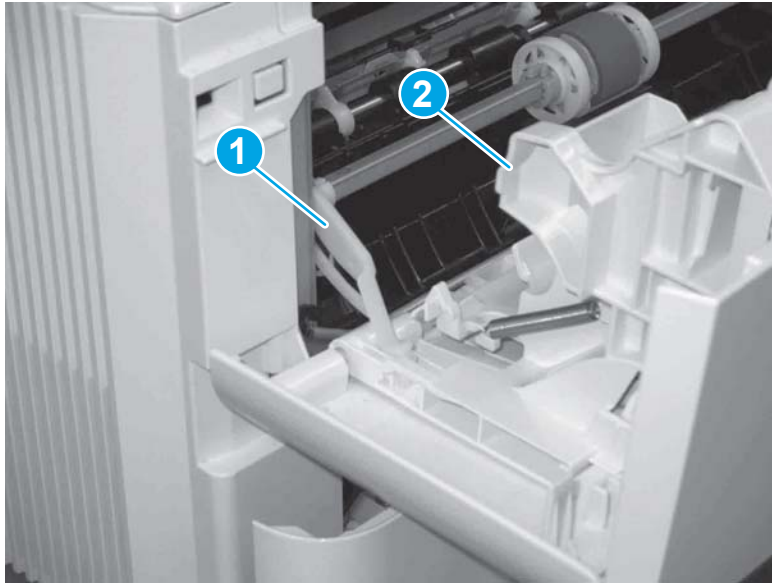

Step 3: Remove the left cover

1. Remove one screw (callout 1).

Figure 1-782 Remove one screw

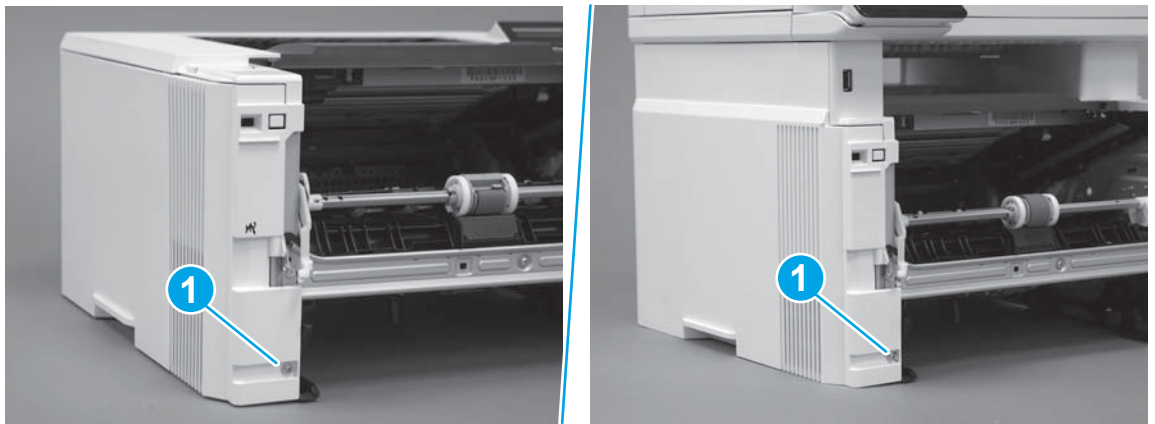

2. Open the rear door, release two bosses (callout 1), and then release three tabs (callout 2).

Figure 1-783 Release two bosses and three tabs

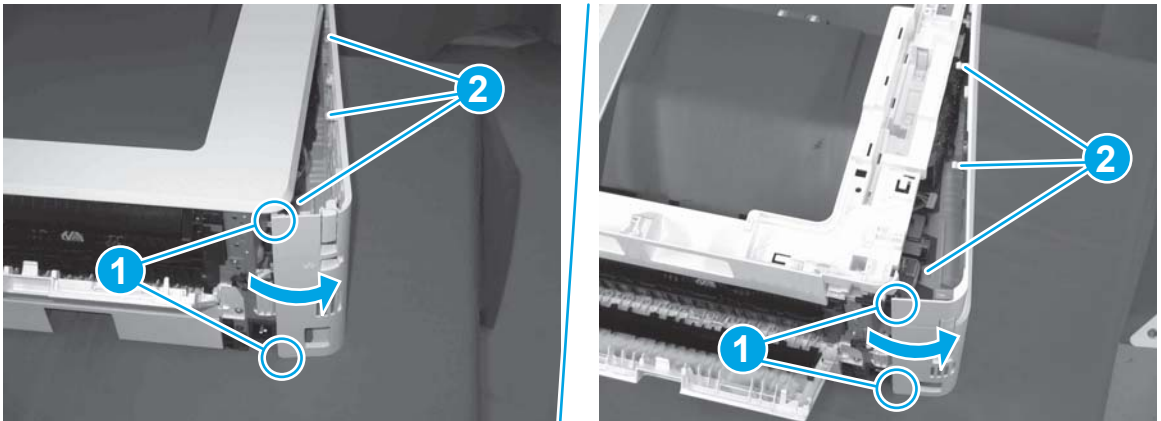

3. At the front of the printer, do one of the following:
 - **M403/M402:** Release two bosses (callout 1), and then remove the cover (callout 2).
 - **M427/M426:** Release one tab (callout 3), two bosses (callout 4), and then remove the cover (callout 5).

CAUTION: Be careful when releasing the upper bosses on the M427/M426 cover. One portion of the cover (callout 6) is fragile and is easily broken.

Figure 1-784 Remove the cover

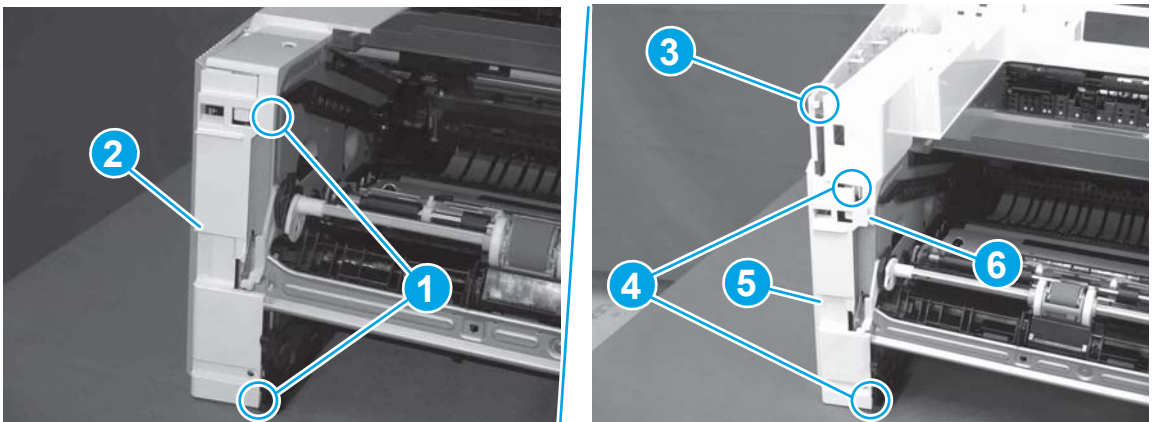

Step 4: Remove the fax PCA (M427/M426)

1. Remove four screws (callout 1).

Figure 1-785 Remove four screws

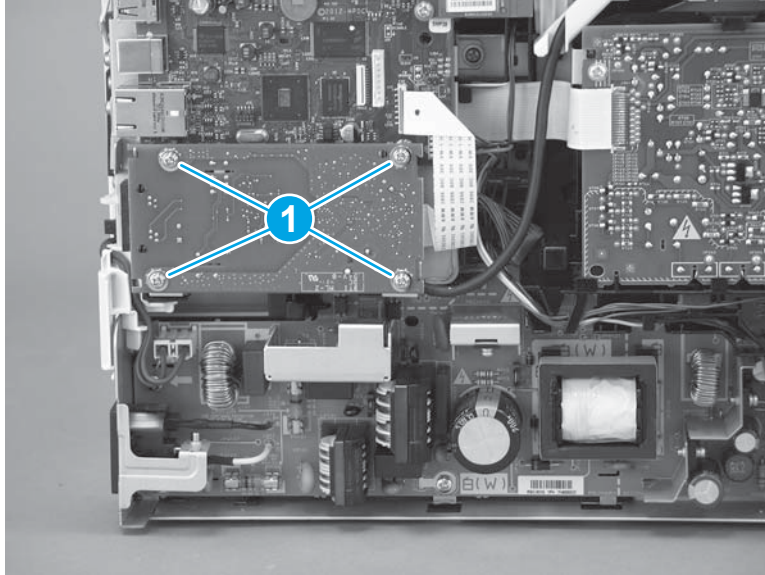

2. Disconnect one FFC (callout 1), and then remove the fax PCA.

Figure 1-786 Disconnect one connector and remove the PCA

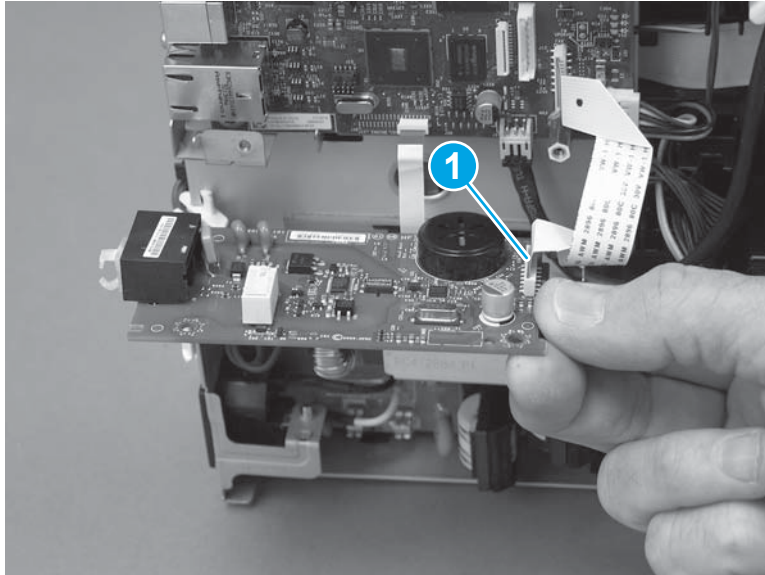

Step 5: Unpack the replacement assembly

Unpack the replacement part from the packaging.

<http://www8.hp.com/us/en/hp-information/environment/product-recycling.html>



NOTE: HP recommends responsible disposal of the defective part.

Figure 1-787 Recycle and unpack

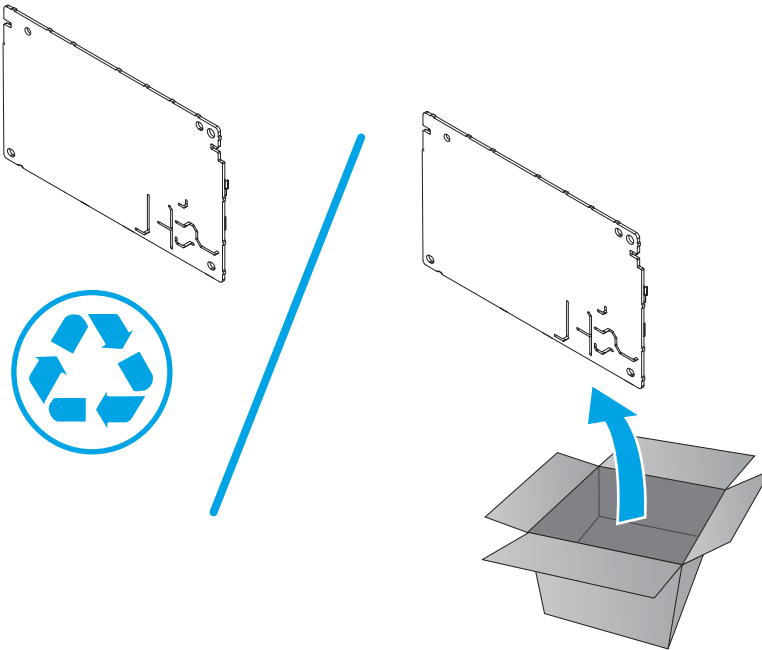

Step 6: Install the fax PCA (M427/M426)

1. Connect one FFC cable (callout 1), and then position the fax PCA on the printer.

Figure 1-788 Connect one connector and install the PCA

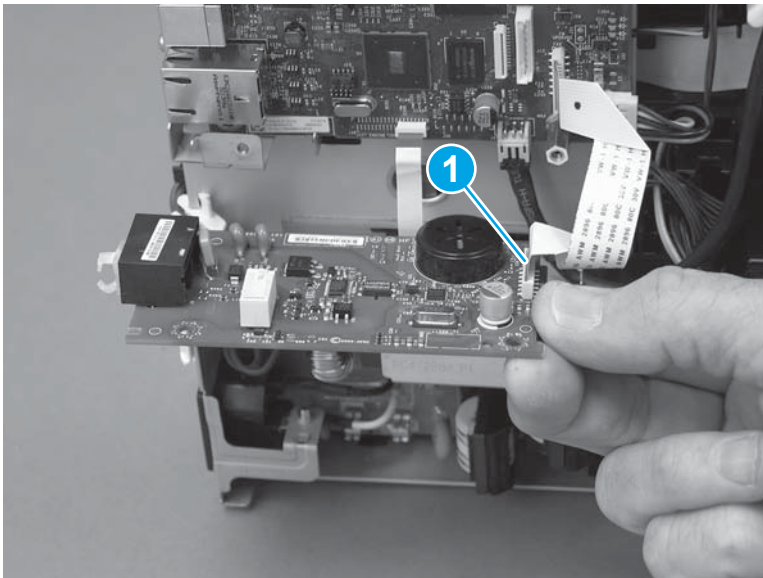

2. Install four screws (callout 1).

Figure 1-789 Install four screws

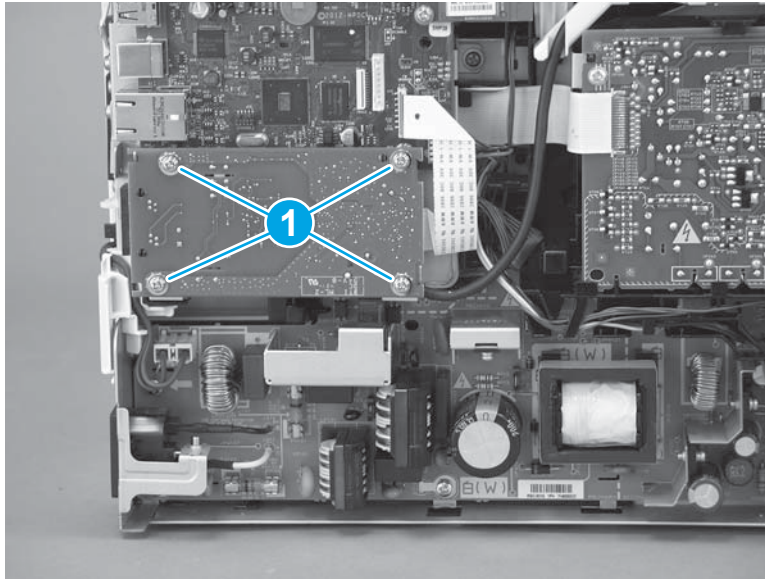

Step 7: Install the left cover

1. At the front of the printer, do one of the following:
 - **M403/M402:** Position the cover on the printer (callout 1), and then engage two bosses (callout 2).
 - **M427/M426:** Position the cover on the printer (callout 3), engage one tab (callout 4), and then engage two bosses (callout 4).

Figure 1-790 Install the cover

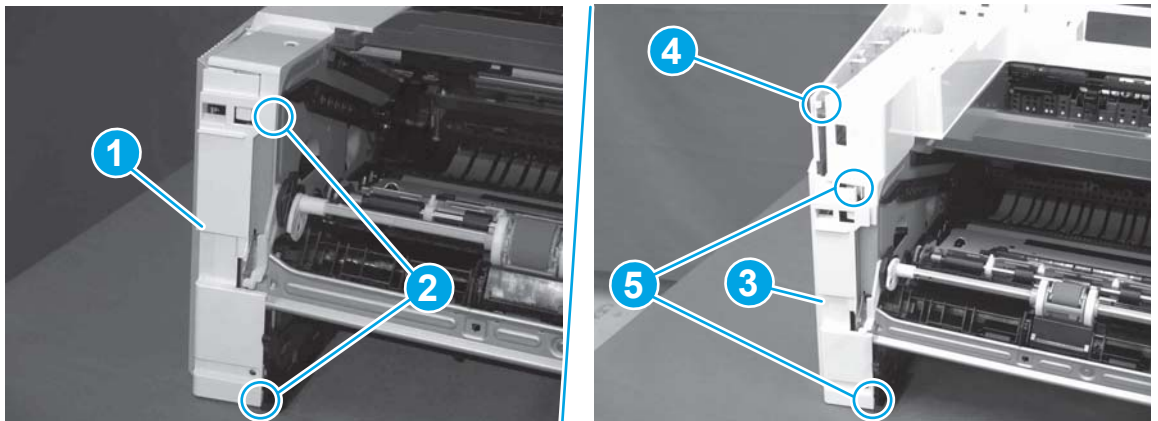

- Carefully rotate the rear of the cover onto the printer (callout 1), engage three tabs (callout 2), and then engage two bosses (callout 3).

Figure 1-791 Engage three tabs and two bosses

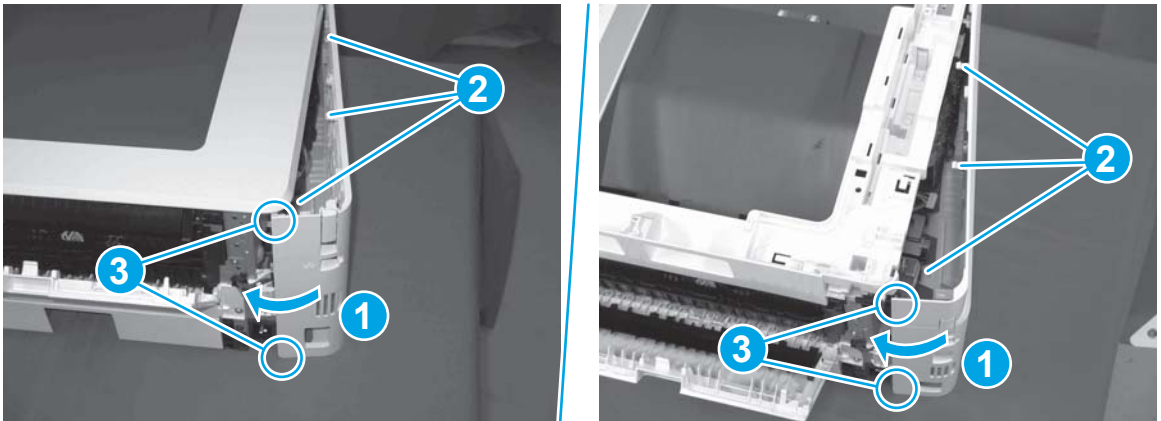

- Install one screw (callout 1).

Figure 1-792 Install one screw

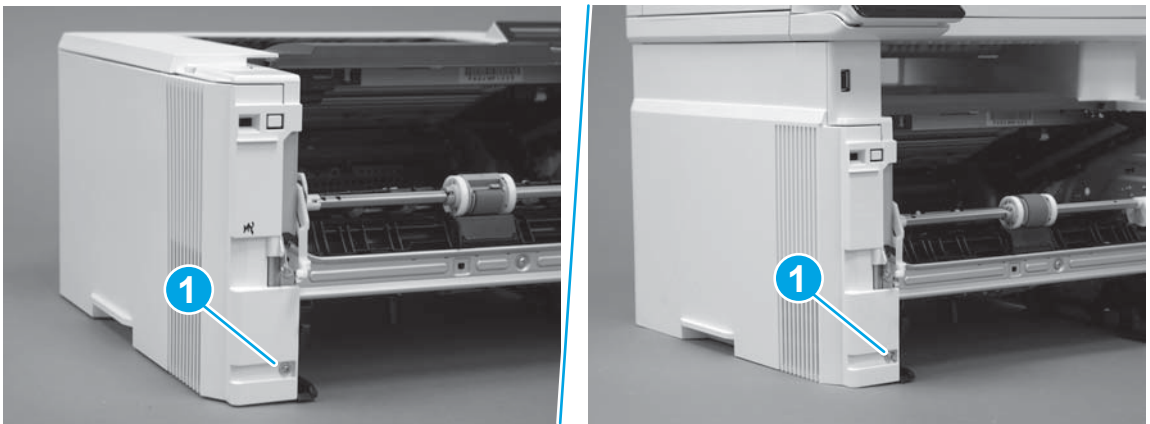

Step 8: Install the cartridge door assembly

 **Reinstallation tip:** After a replacement door is installed, make sure to install the nameplate (supplied in the kit) corresponding to the printer name on the door.

- Position the door close to the printer, and then engage the keyed pin on the left-side retainer arm with the hole in the door.

Figure 1-793 Engage the left-side retainer arm

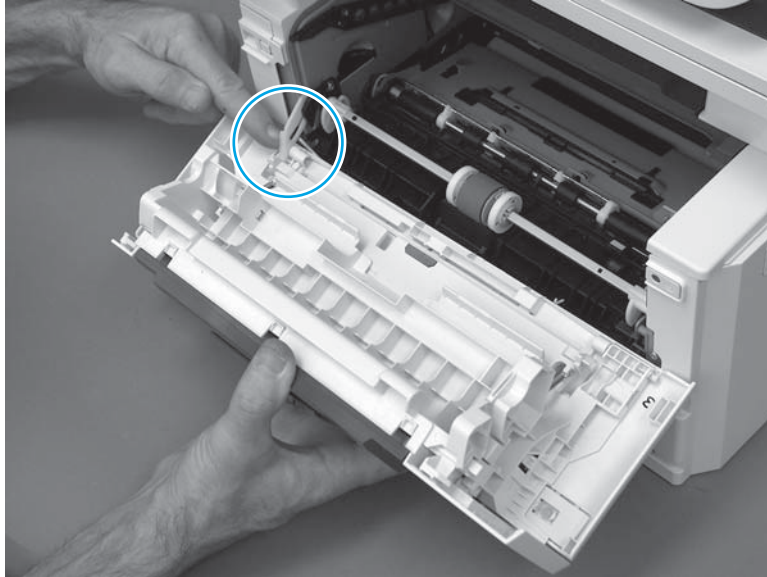

2. Engage the right-side door hinge pin with the hole in the chassis (callout 1).

Figure 1-794 Install the door

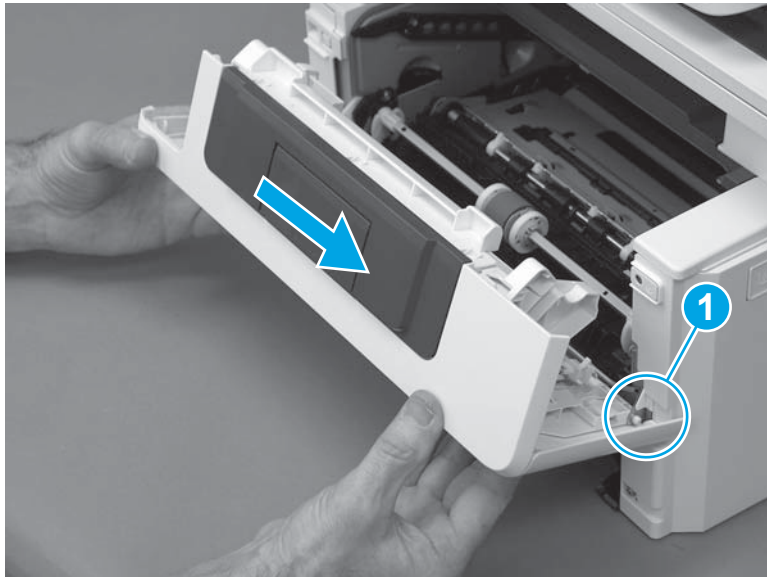

3. Install the link (callout 1).

 **IMPORTANT:** Make sure that the link snaps into place on the arm (callout 2). The link actuates the fuser pressure-release mechanism.

Figure 1-795 Install the pressure-release link

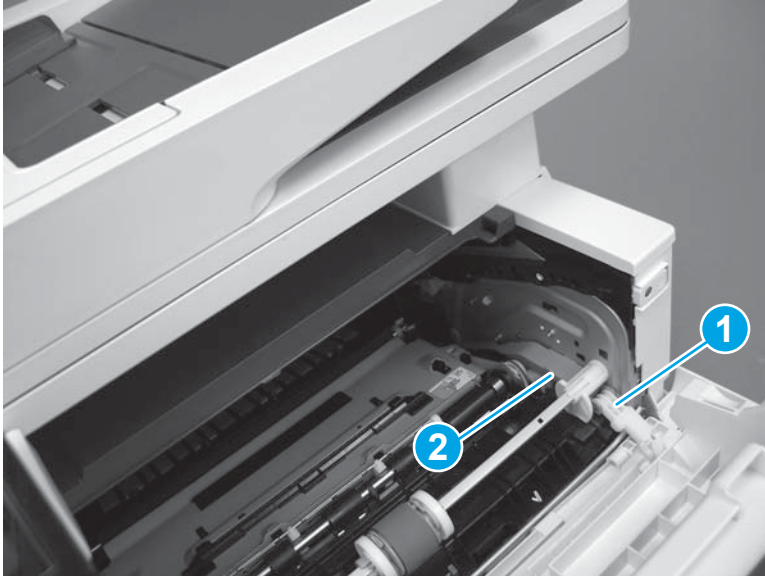

4. Slide the guide into the printer (callout 1), and then make sure that the tab (callout 2) snaps into place to secure the guide to the chassis.

Figure 1-796 Install the guide

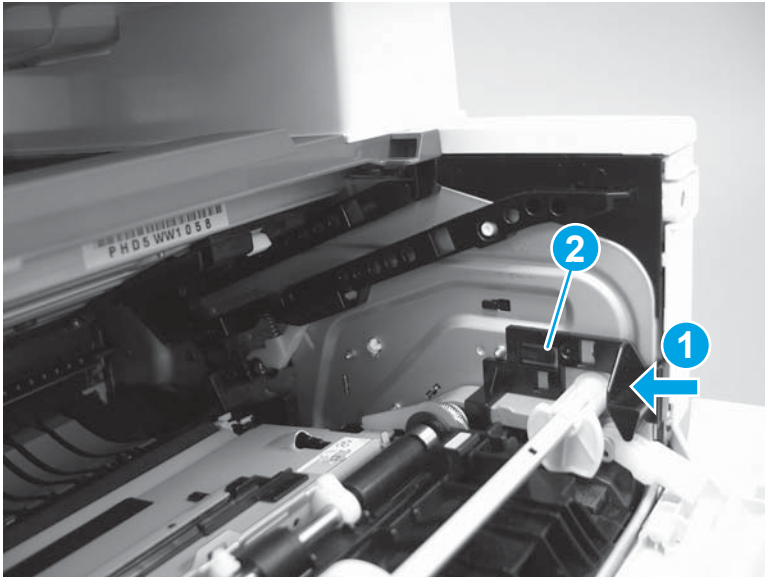

5. Position the shaft on the door, and then align the left-side hinge on the door with the hole in the chassis (callout 1).

Figure 1-797 Align the hinge

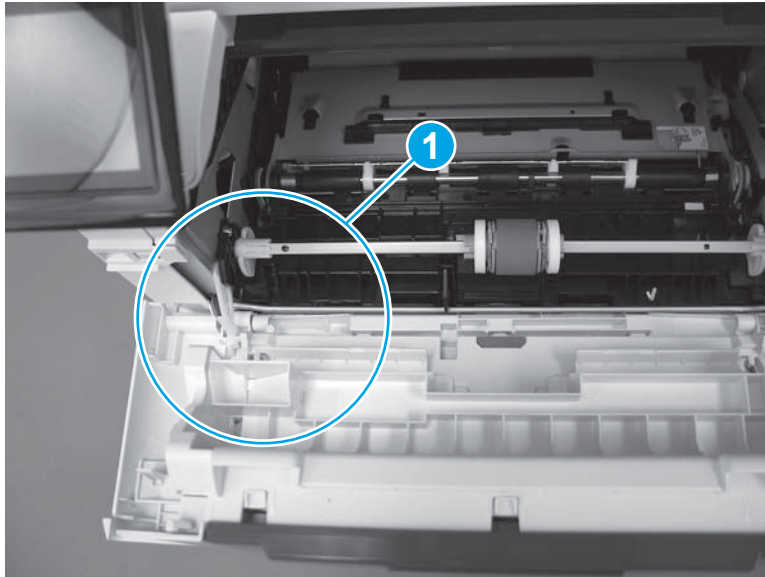

6. Push the shaft towards the left side of the printer to install it (callout 1).

 **Reinstallation tip:** Make sure that the support shaft is fully installed and correctly orientated (callout 2) so that it will not interfere with the door opening and closing.

Figure 1-798 Install the support shaft



Step 9: Install Tray 2

- ▲ Slide the tray straight into the printer to install it.

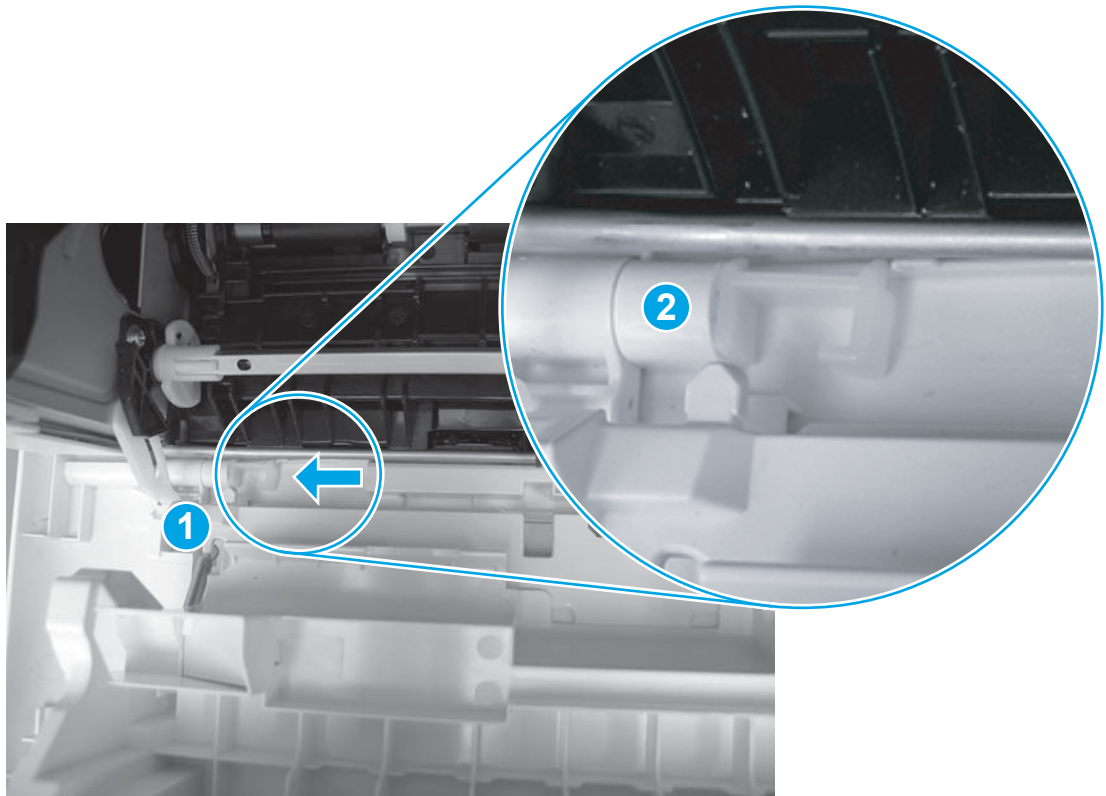
Figure 1-799 Install the tray



Removal and replacement: Walkup USB PCA (M427/M426)

- [Introduction](#)
- [Step 1: Remove Tray 2](#)
- [Step 2: Remove the cartridge door assembly](#)
- [Step 3: Remove the left cover](#)
- [Step 4: Remove the fax PCA](#)
- [Step 5: Remove the walkup USB PCA \(M427/M426\)](#)
- [Step 6: Unpack the replacement assembly](#)
- [Step 7: Install the walkup USB PCA \(M427/M426\)](#)
- [Step 8: Install the fax PCA](#)
- [Step 9: Install the left cover](#)
- [Step 10: Install the cartridge door assembly](#)
- [Step 9: Install Tray 2](#)

Introduction

This document provides the procedures to remove and replace the walkup USB PCA.

Before performing service

Turn the printer power off

- Disconnect the power cable.

 **WARNING!** To avoid damage to the printer, turn the printer off, wait 30 seconds, and then remove the power cable before attempting to service the printer.

Use the table below to identify the correct part number for your printer. To order the part, go to www.hp.com/buy/parts.

Walkup USB PCA part number	
CF368-60001	Walkup USB PCA ¹

¹ M427/M426 only.

Required tools

- #2 Phillips screwdriver with a magnetic tip.

After performing service

Turn the printer power on

- Connect the power cable.
- Use the power switch to turn the power on.

Post service test

Make sure that the printer initializes to a **Ready** state.

Print a job from the walkup USB PCA.

Step 1: Remove Tray 2

- ▲ Pull the tray straight out of the printer to remove it.

Figure 1-800 Remove the tray



Step 2: Remove the cartridge door assembly



NOTE: If the toner cartridge was not removed prior to servicing the printer, remove it now.

1. Release one tab (callout 1), and then slide shaft (callout 2) in the direction the arrow indicates and remove it.



TIP: It might be easier to release the support shaft by using a small flat-blade screwdriver.

Figure 1-801 Release the support shaft

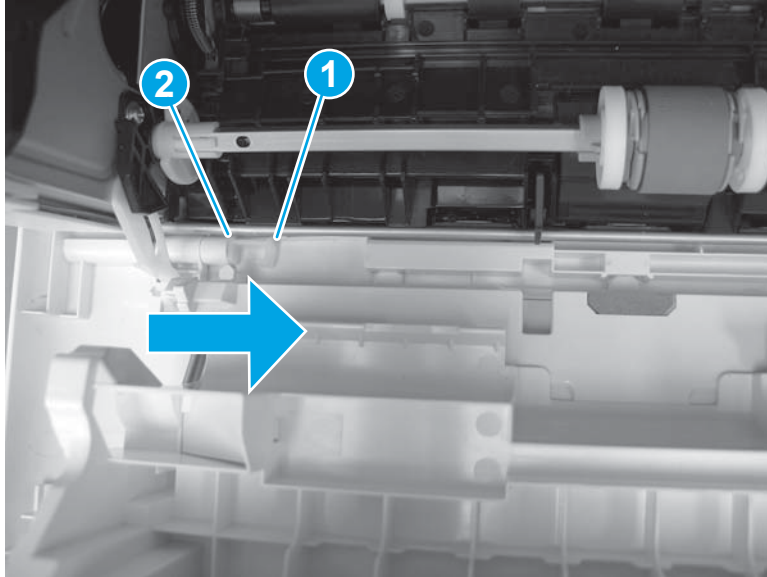

2. Release one tab (callout 1), and then slide the guide (callout 2) in the direction the arrow indicates and remove it.

Figure 1-802 Remove the guide

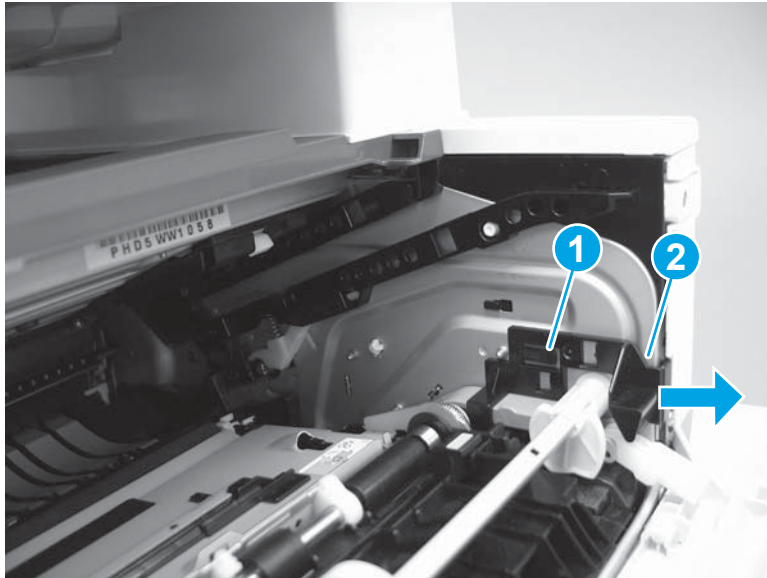

3. Remove the link arm (callout 1).

Figure 1-803 Remove the link arm

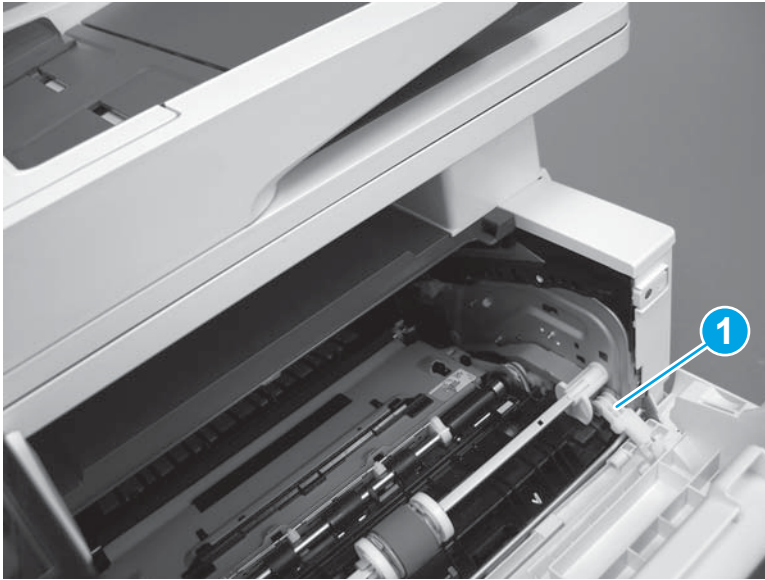

4. Slide the cartridge door assembly (callout 1) in the direction the arrow indicates and remove it.

Figure 1-804 Remove the door

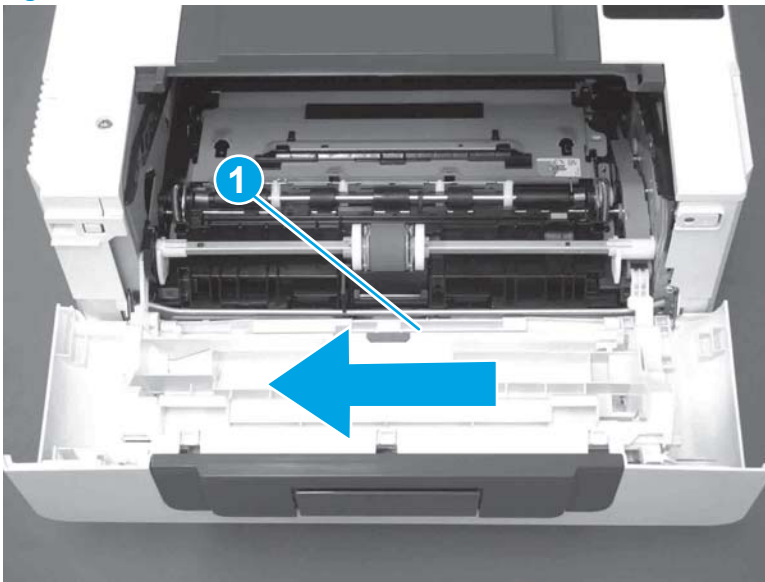

5. Remove the link (callout 1) from the cartridge door assembly (callout 2).

Figure 1-805 Release the left-side retainer arm

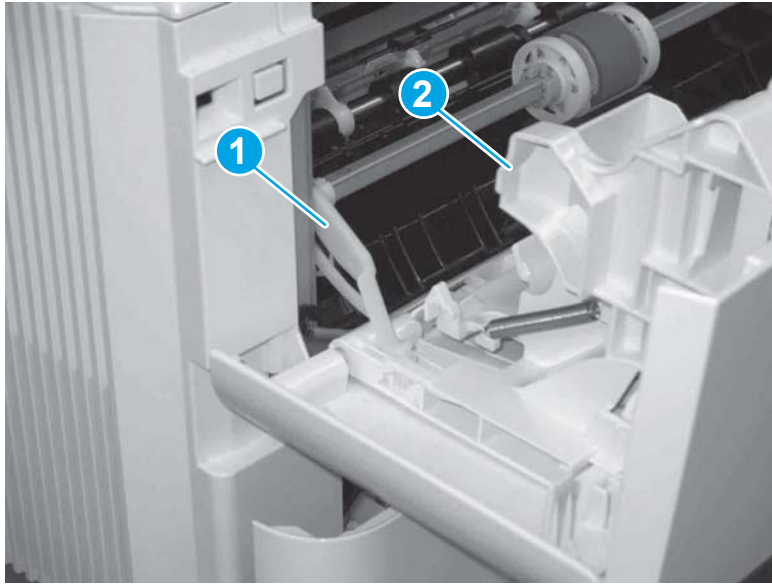

Step 3: Remove the left cover

1. Remove one screw (callout 1).

Figure 1-806 Remove one screw

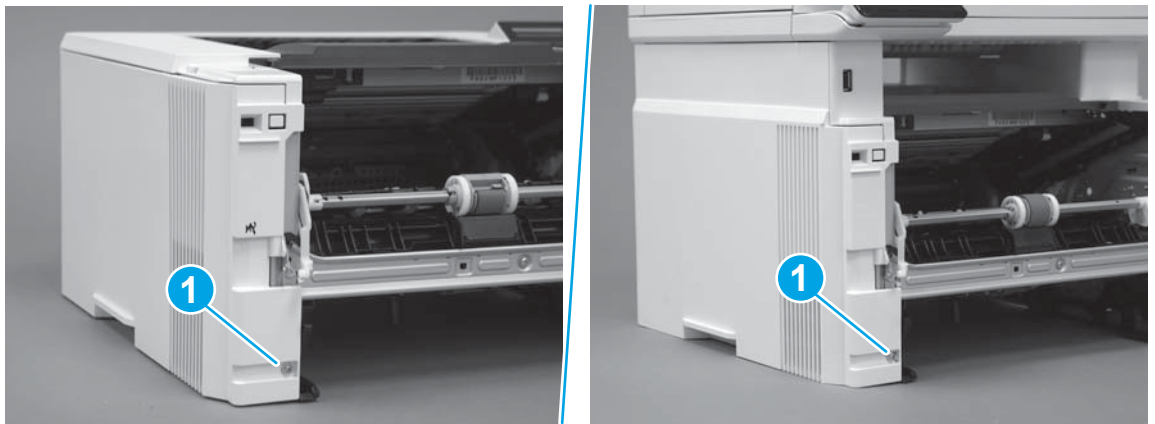

2. Open the rear door, release two bosses (callout 1), and then release three tabs (callout 2).

Figure 1-807 Release two bosses and three tabs

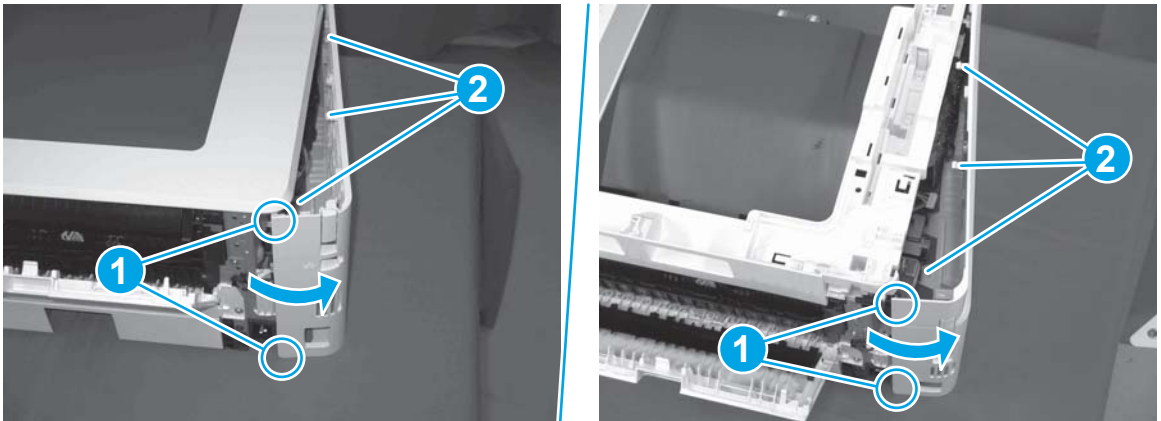

3. At the front of the printer, do one of the following:
 - **M403/M402:** Release two bosses (callout 1), and then remove the cover (callout 2).
 - **M427/M426:** Release one tab (callout 3), two bosses (callout 4), and then remove the cover (callout 5).

CAUTION: Be careful when releasing the upper bosses on the M427/M426 cover. One portion of the cover (callout 6) is fragile and is easily broken.

Figure 1-808 Remove the cover

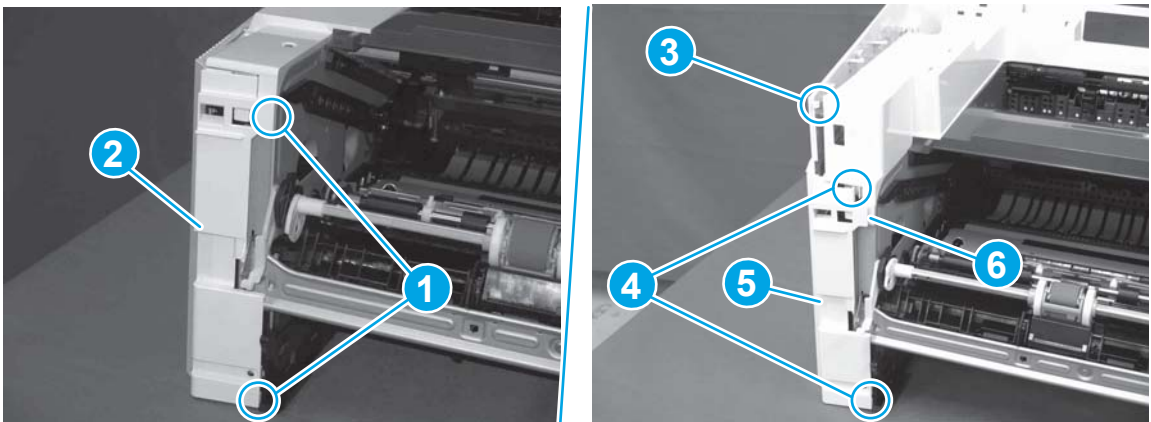

Step 4: Remove the fax PCA

NOTE: Fax models only. For all other models, skip this step and go to [Step 5: Remove the walkup USB PCA \(M427/M426\)](#) on page 449.

1. Remove four screws (callout 1).

Figure 1-809 Remove four screws

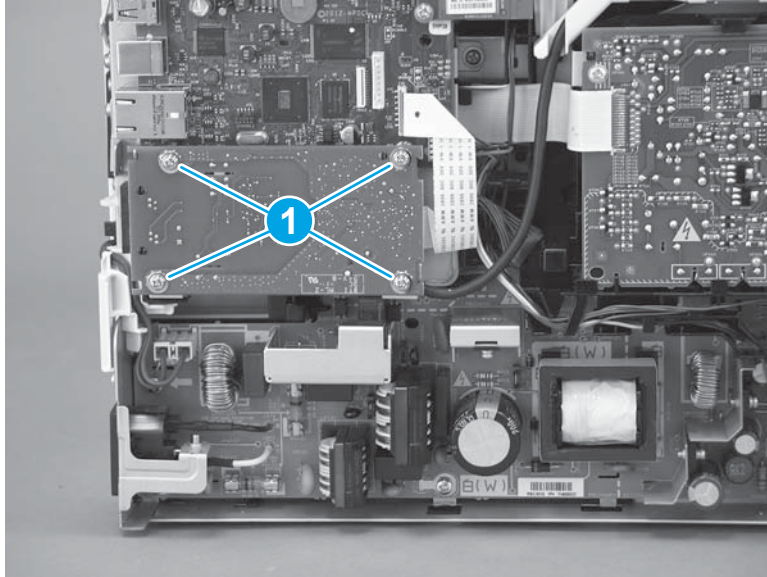

2. Disconnect one FFC (callout 1), and then remove the fax PCA.

Figure 1-810 Disconnect one connector and remove the PCA

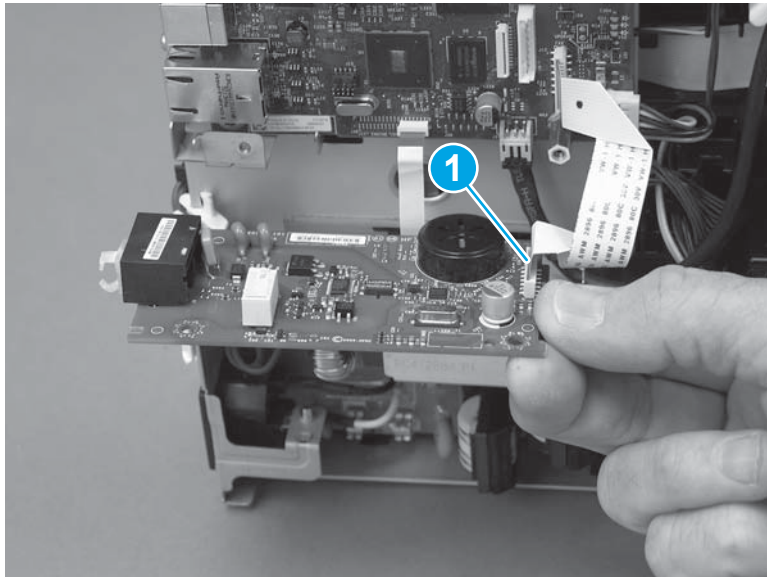

Step 5: Remove the walkup USB PCA (M427/M426)

1. Disconnect one connector (callout 1), and then release the wire harness from the guide (callout 2).

Figure 1-811 Disconnect one connector

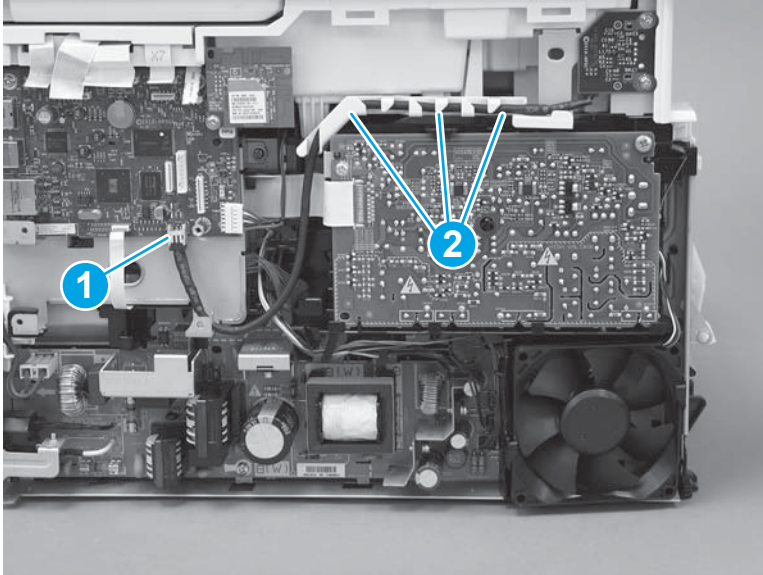

2. Remove two screws (callout 1).

Figure 1-812 Remove two screws

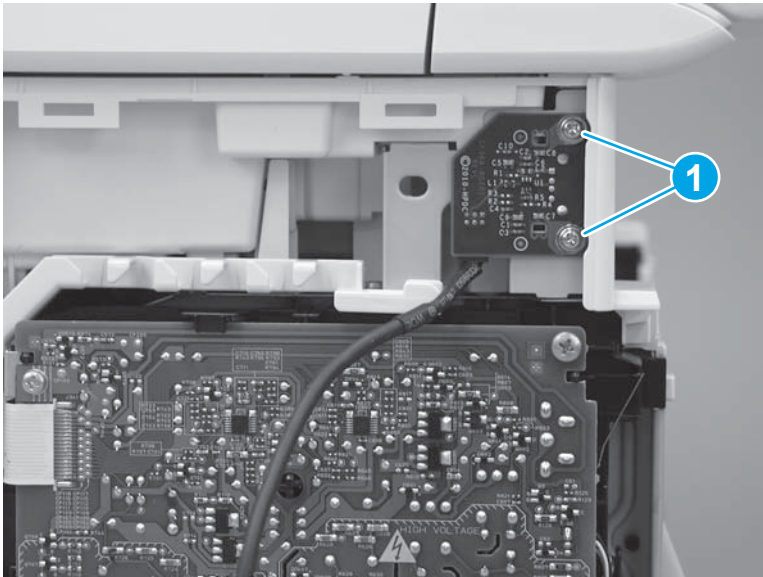

3. Remove the wakeup USB PCA.

Figure 1-813 Remove the wakeup USB PCA

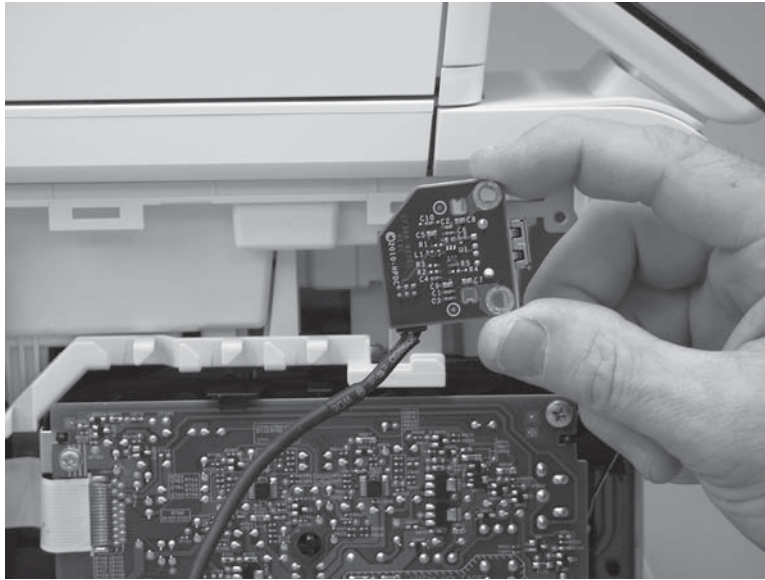

Step 6: Unpack the replacement assembly

Unpack the replacement part from the packaging.

<http://www8.hp.com/us/en/hp-information/environment/product-recycling.html>

 **NOTE:** HP recommends responsible disposal of the defective part.

Figure 1-814 Recycle and unpack

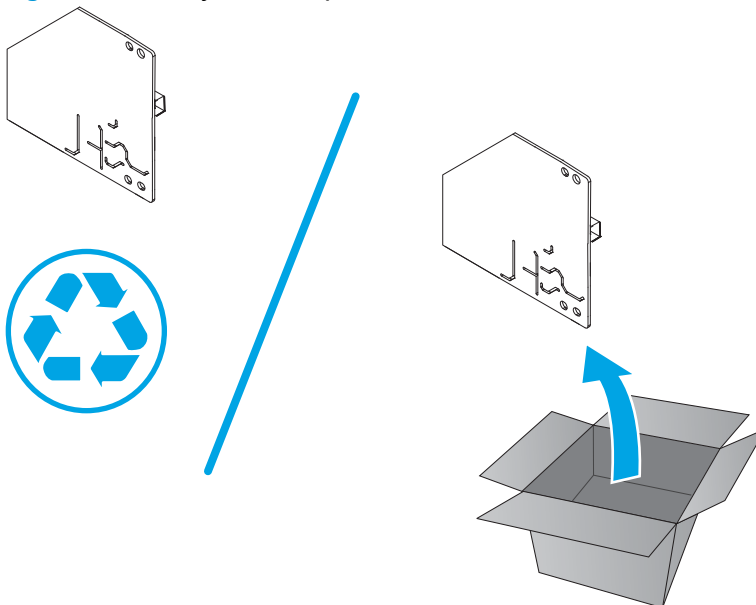

Step 7: Install the wakeup USB PCA (M427/M426)

1. Position the wakeup USB PCA on the printer.

Figure 1-815 Install the walkup USB PCA

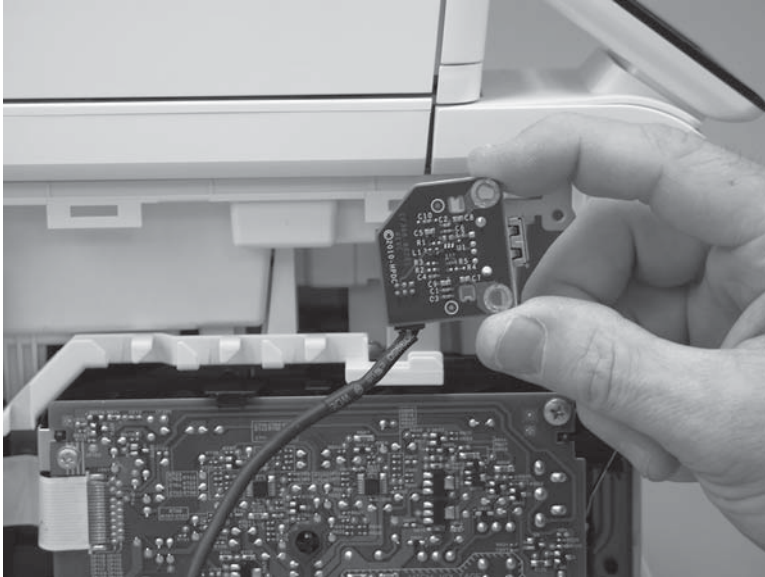

2. Install two screws (callout 1).

Figure 1-816 Install two screws

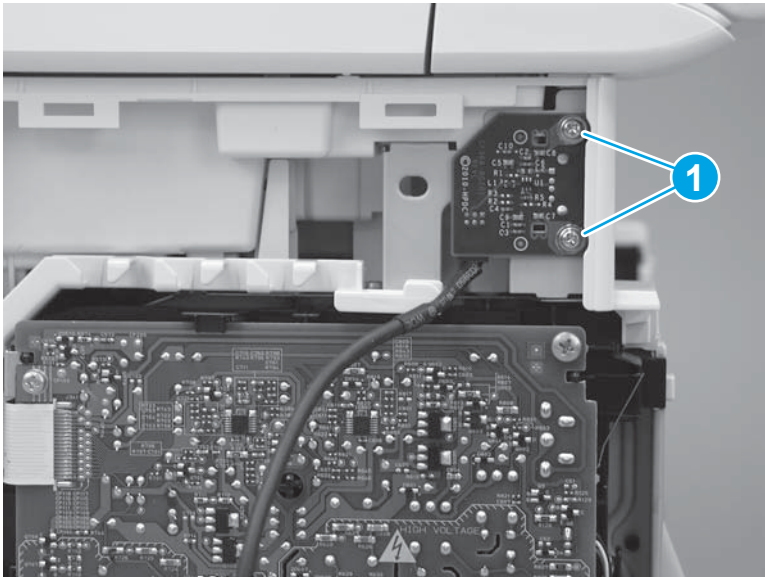

3. Connect one connector (callout 1), and then install the wire harness in the guide (callout 2).

Figure 1-817 Connect one connector

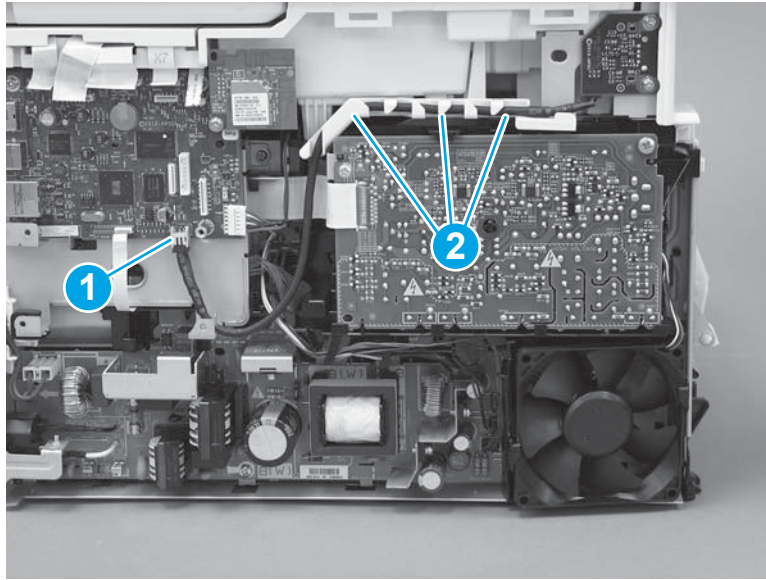

Step 8: Install the fax PCA

 **NOTE:** Fax models only. For all other models, skip this step and go to [Step 9: Install the left cover on page 454](#).

1. Connect one FFC cable (callout 1), and then position the fax PCA on the printer.

Figure 1-818 Connect one connector and install the PCA

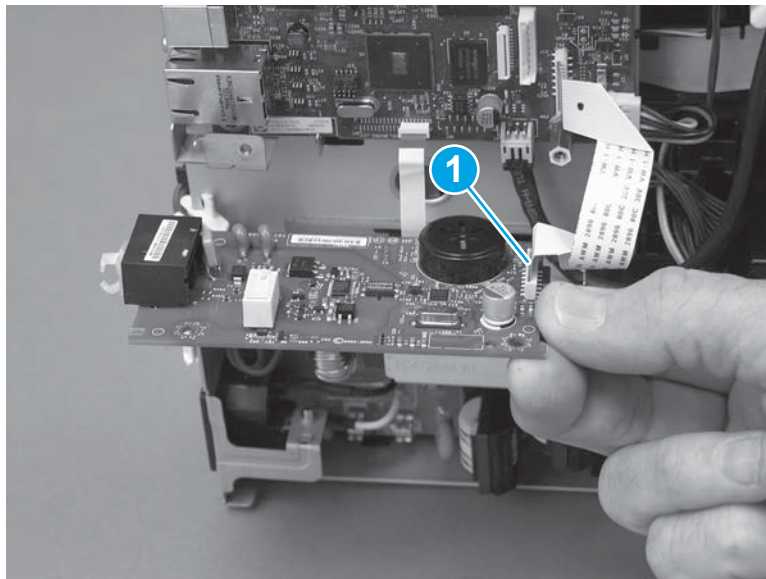

2. Install four screws (callout 1).

Figure 1-819 Install four screws

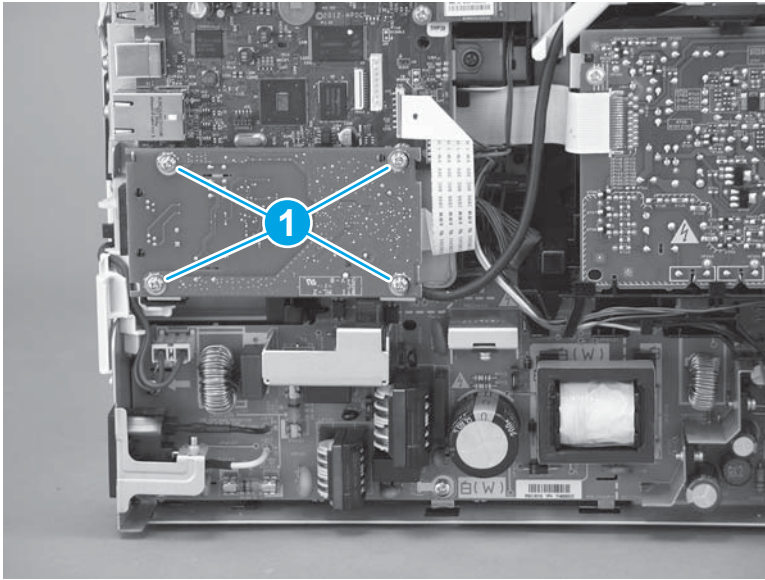

Step 9: Install the left cover

1. At the front of the printer, do one of the following:
 - **M403/M402:** Position the cover on the printer (callout 1), and then engage two bosses (callout 2).
 - **M427/M426:** Position the cover on the printer (callout 3), engage one tab (callout 4), and then engage two bosses (callout 4).

Figure 1-820 Install the cover

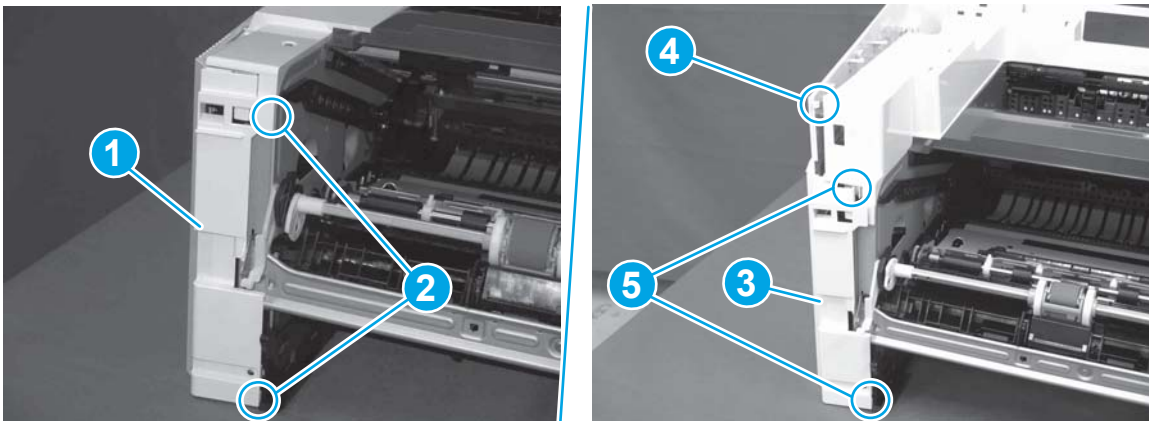

- Carefully rotate the rear of the cover onto the printer (callout 1), engage three tabs (callout 2), and then engage two bosses (callout 3).

Figure 1-821 Engage three tabs and two bosses

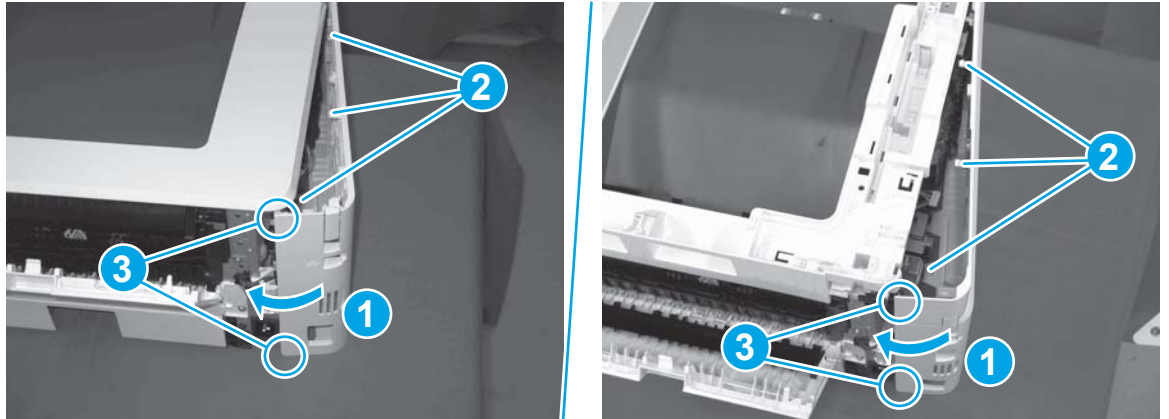

- Install one screw (callout 1).

Figure 1-822 Install one screw

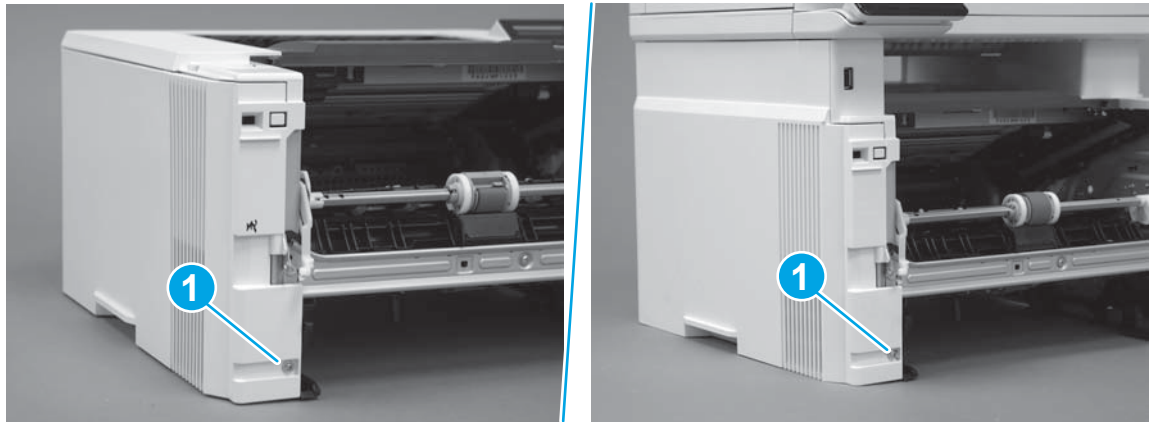

Step 10: Install the cartridge door assembly

 **Reinstallation tip:** After a replacement door is installed, make sure to install the nameplate (supplied in the kit) corresponding to the printer name on the door.

- Position the door close to the printer, and then engage the keyed pin on the left-side retainer arm with the hole in the door.

Figure 1-823 Engage the left-side retainer arm

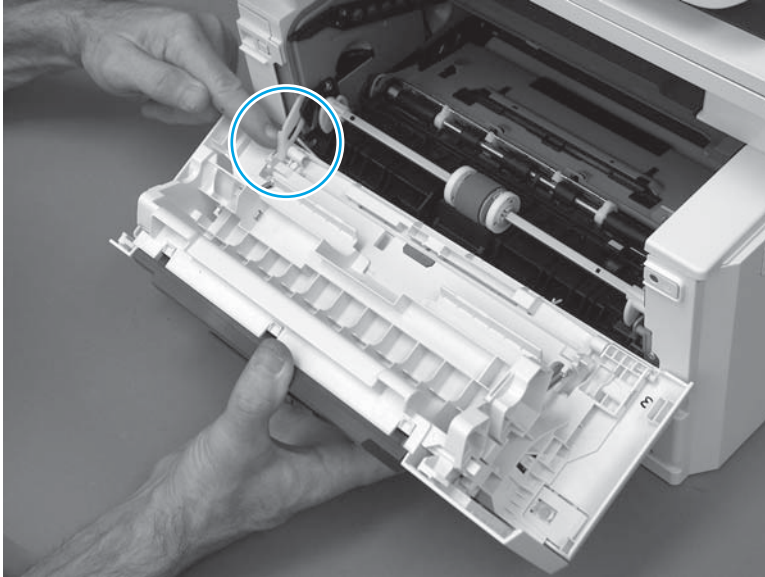

2. Engage the right-side door hinge pin with the hole in the chassis (callout 1).

Figure 1-824 Install the door

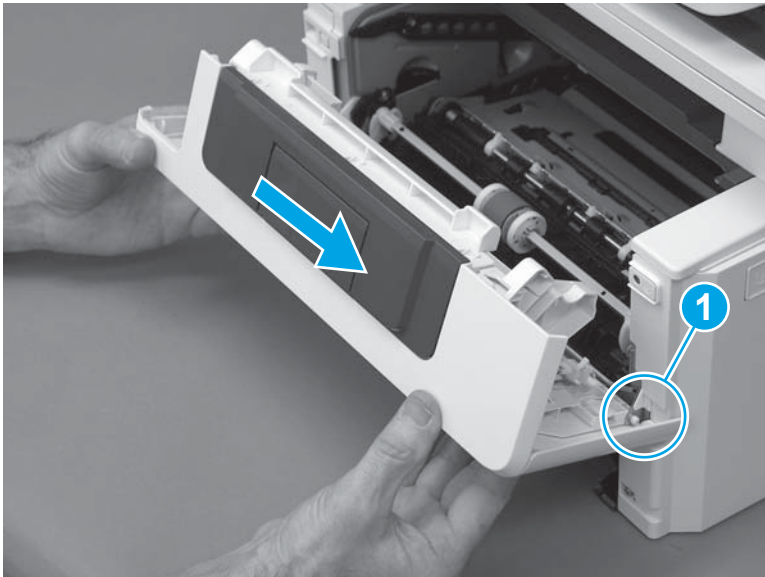

3. Install the link (callout 1).

 **IMPORTANT:** Make sure that the link snaps into place on the arm (callout 2). The link actuates the fuser pressure-release mechanism.

Figure 1-825 Install the pressure-release link

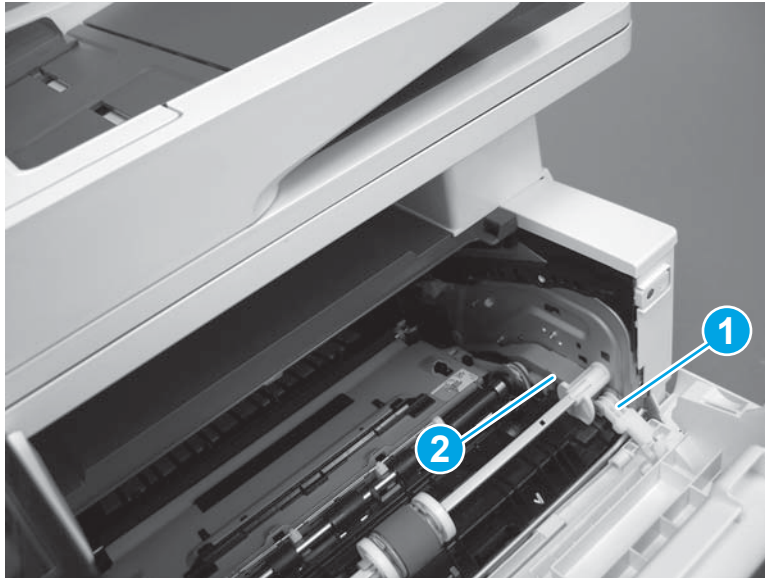

4. Slide the guide into the printer (callout 1), and then make sure that the tab (callout 2) snaps into place to secure the guide to the chassis.

Figure 1-826 Install the guide

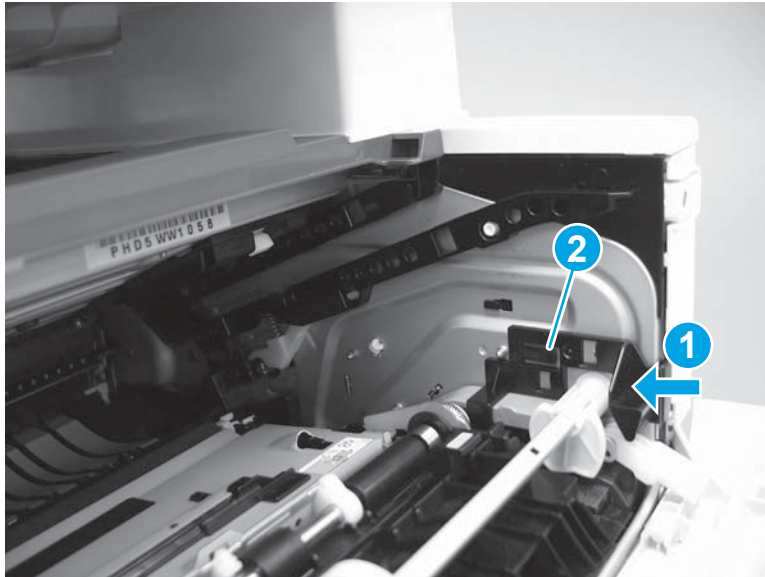

5. Position the shaft on the door, and then align the left-side hinge on the door with the hole in the chassis (callout 1).

Figure 1-827 Align the hinge

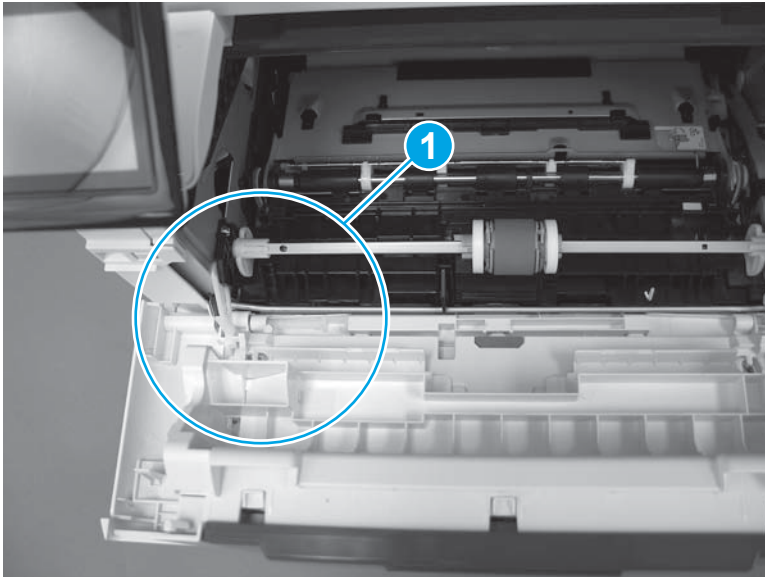

6. Push the shaft towards the left side of the printer to install it (callout 1).

 **Reinstallation tip:** Make sure that the support shaft is fully installed and correctly orientated (callout 2) so that it will not interfere with the door opening and closing.

Figure 1-828 Install the support shaft



Step 9: Install Tray 2

- ▲ Slide the tray straight into the printer to install it.

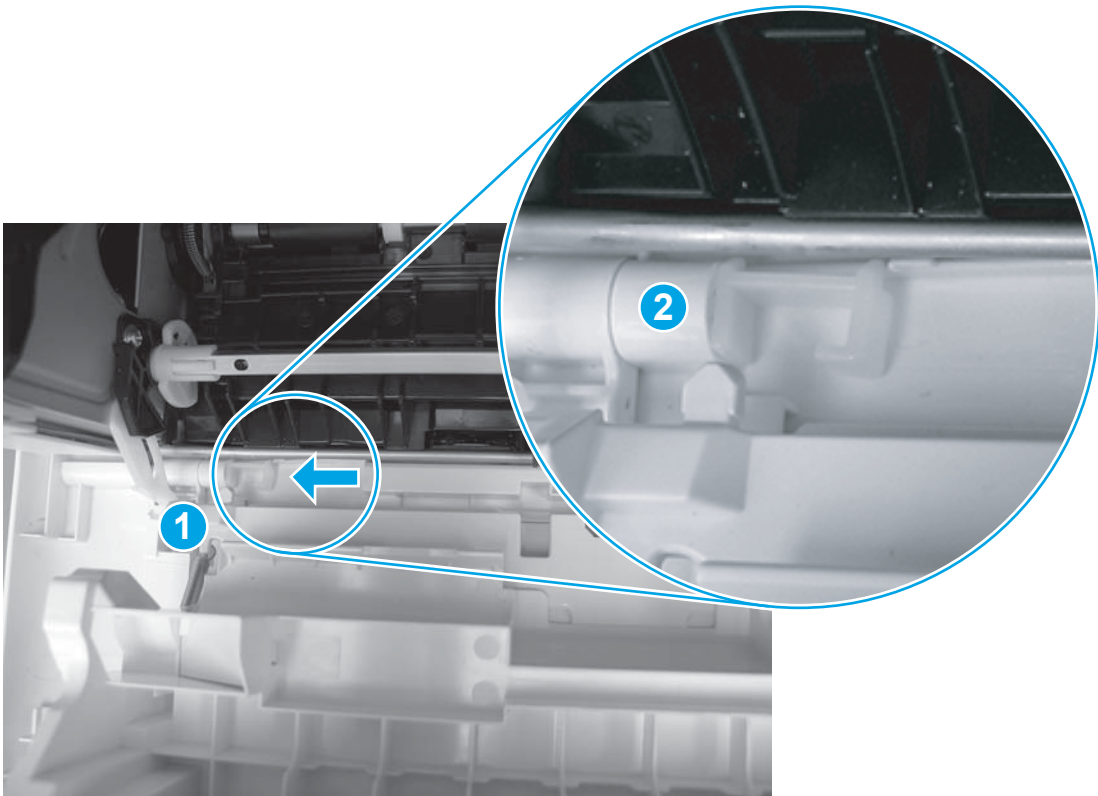
Figure 1-829 Install the tray



Removal and replacement: Wireless PCA



NOTE: Wireless models only.

- [Introduction](#)
- [Step 1: Remove Tray 2](#)
- [Step 2: Remove the cartridge door assembly](#)
- [Step 3: Remove the left cover](#)
- [Step 4: Remove the wireless PCA](#)
- [Step 5: Unpack the replacement assembly](#)
- [Step 6: Install the wireless PCA](#)
- [Step 7: Install the left cover](#)
- [Step 8: Install the cartridge door assembly](#)
- [Step 9: Install Tray 2](#)

Introduction

This document provides the procedures to remove and replace the wireless printed circuit assembly (PCA).

Before performing service

Turn the printer power off

- Disconnect the power cable.



WARNING! To avoid damage to the printer, turn the printer off, wait 30 seconds, and then remove the power cable before attempting to service the printer.

Use the table below to identify the correct part number for your printer. To order the part, go to www.hp.com/buy/parts.

Wireless PCA part number	
0960-3293	Wireless module ¹

¹ M427/M426 and M403/M402 wireless models only.

Required tools

- #2 Phillips screwdriver with a magnetic tip.

After performing service

Turn the printer power on

- Connect the power cable.
- Use the power switch to turn the power on.

Post service test

Make sure that the printer initializes to a **Ready** state.

If possible, send a wireless print job to the printer.

Step 1: Remove Tray 2

- ▲ Pull the tray straight out of the printer to remove it.

Figure 1-830 Remove the tray



Step 2: Remove the cartridge door assembly

 **NOTE:** If the toner cartridge was not removed prior to servicing the printer, remove it now.

1. Release one tab (callout 1), and then slide shaft (callout 2) in the direction the arrow indicates and remove it.

 **TIP:** It might be easier to release the support shaft by using a small flat-blade screwdriver.

Figure 1-831 Release the support shaft

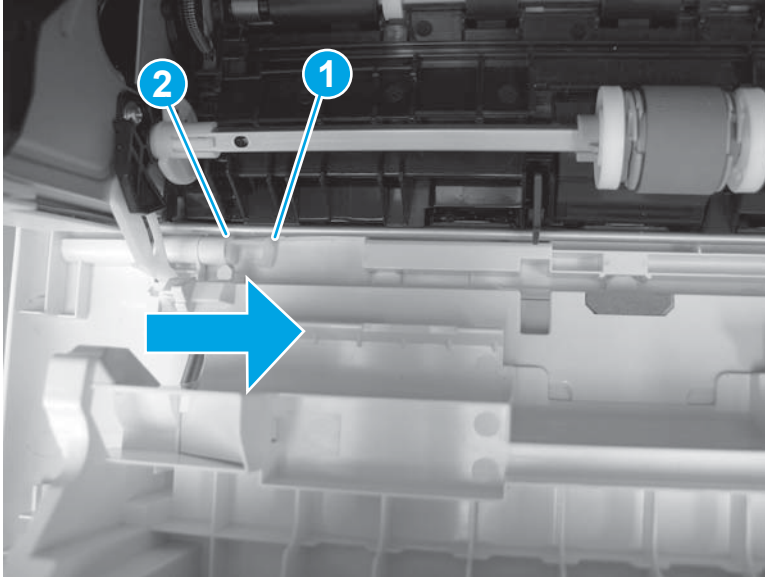

2. Release one tab (callout 1), and then slide the guide (callout 2) in the direction the arrow indicates and remove it.

Figure 1-832 Remove the guide

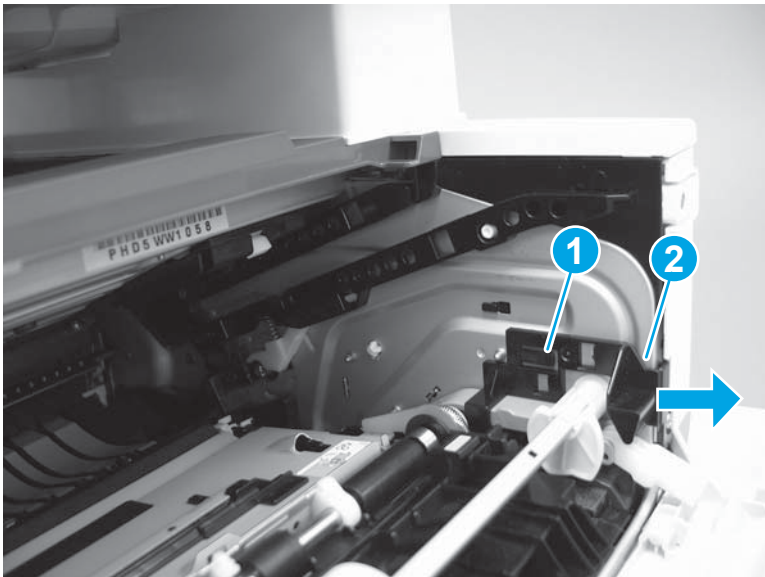

3. Remove the link arm (callout 1).

Figure 1-833 Remove the link arm

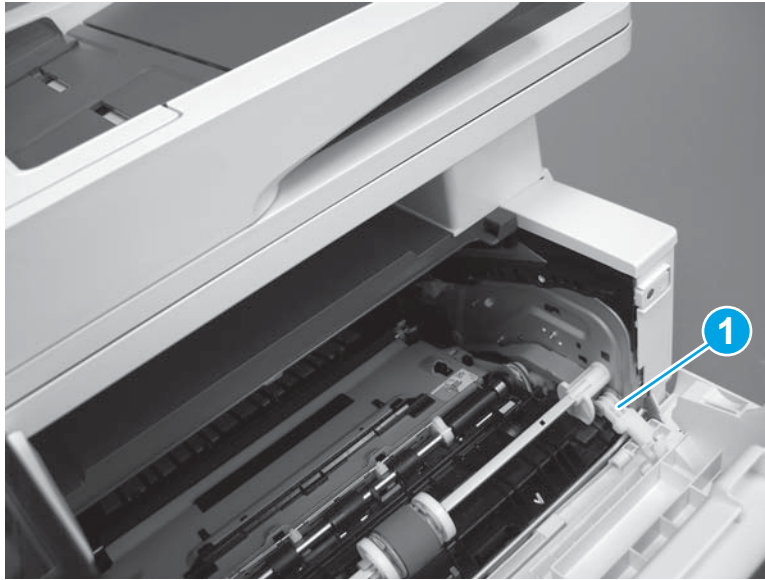

4. Slide the cartridge door assembly (callout 1) in the direction the arrow indicates and remove it.

Figure 1-834 Remove the door

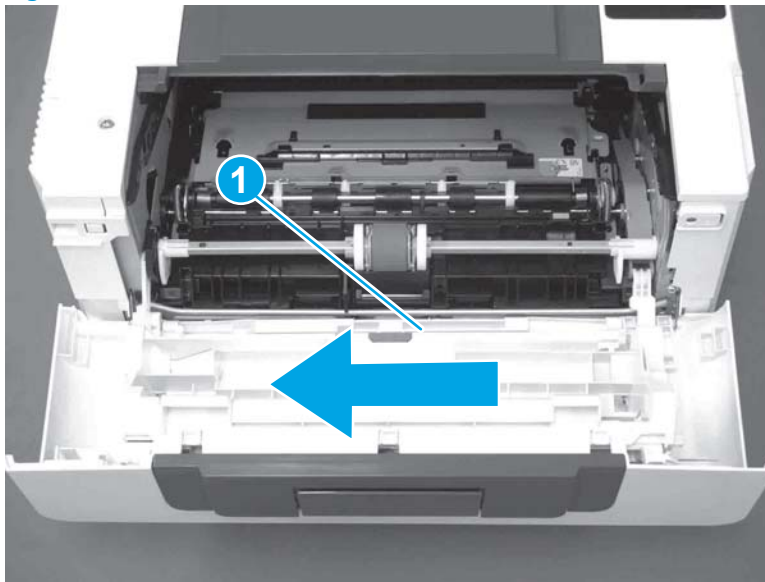

5. Remove the link (callout 1) from the cartridge door assembly (callout 2).

Figure 1-835 Release the left-side retainer arm

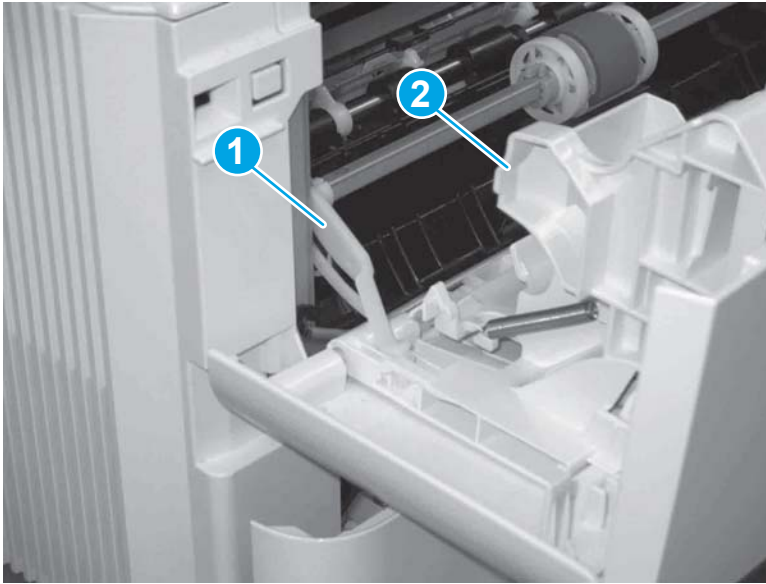

Step 3: Remove the left cover

1. Remove one screw (callout 1).

Figure 1-836 Remove one screw

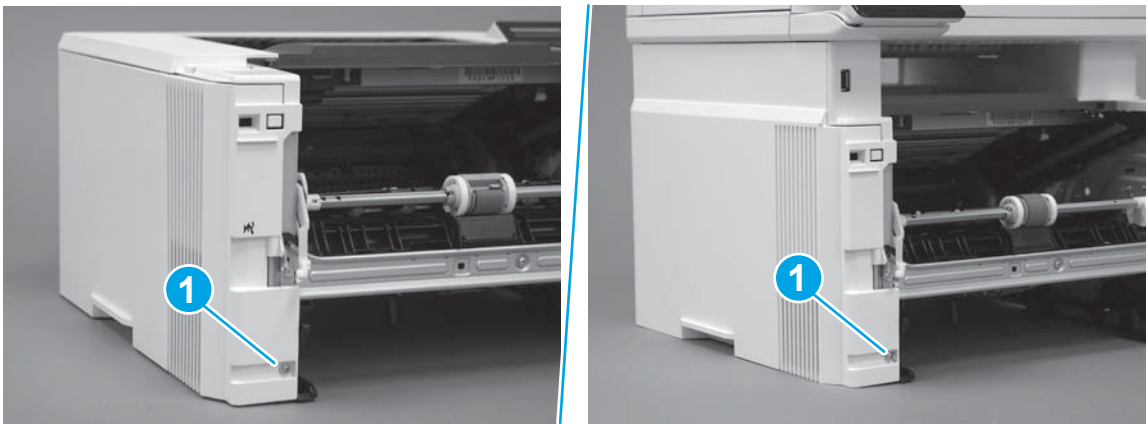

2. Open the rear door, release two bosses (callout 1), and then release three tabs (callout 2).

Figure 1-837 Release two bosses and three tabs

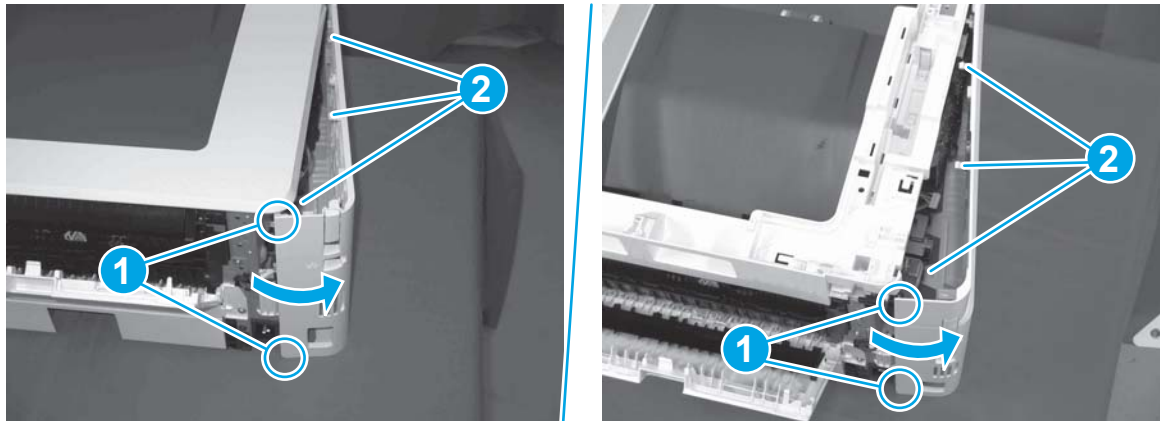

3. At the front of the printer, do one of the following:

- **M403/M402:** Release two bosses (callout 1), and then remove the cover (callout 2).
- **M427/M426:** Release one tab (callout 3), two bosses (callout 4), and then remove the cover (callout 5).

CAUTION: Be careful when releasing the upper bosses on the M427/M426 cover. One portion of the cover (callout 6) is fragile and is easily broken.

Figure 1-838 Remove the cover

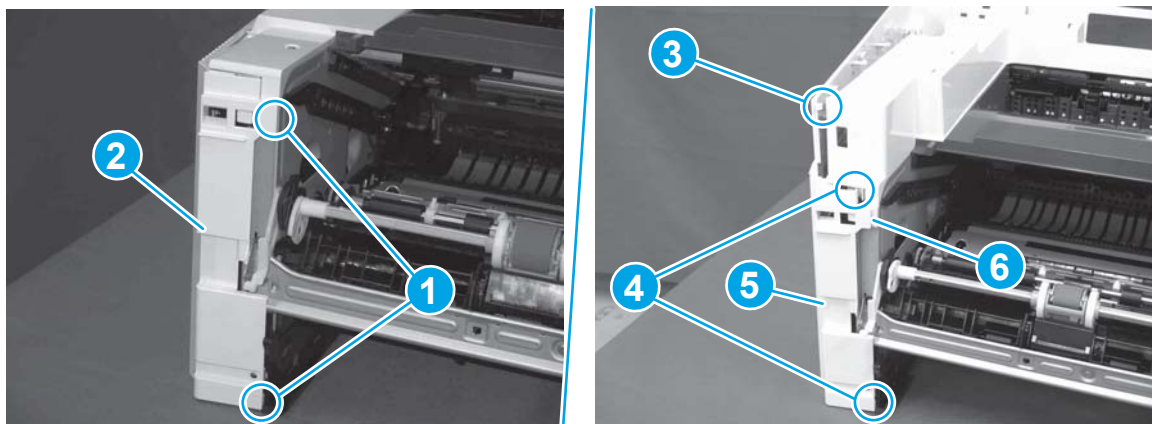

Step 4: Remove the wireless PCA

1. Remove one screw (callout 1).

Figure 1-839 Remove one screw

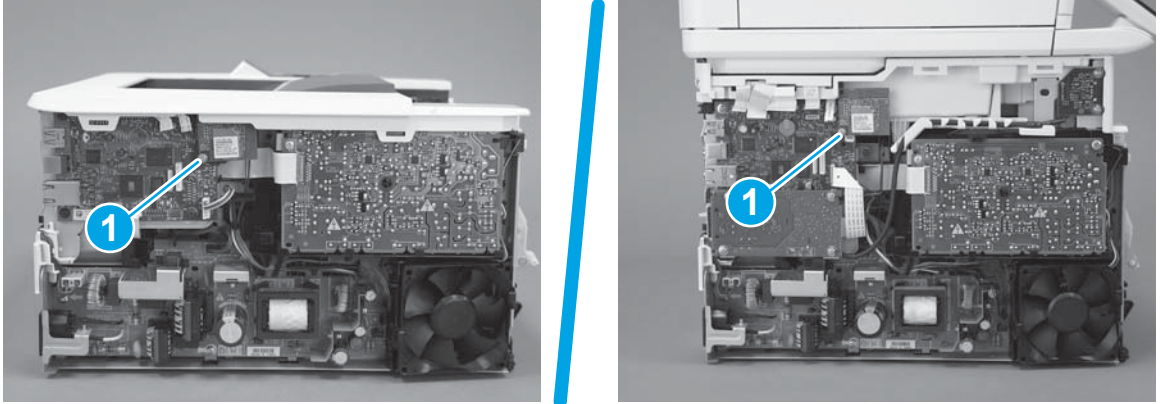

2. Carefully pull the wireless PCA straight off of the formatter PCA to remove it.

Figure 1-840 Remove the wireless PCA

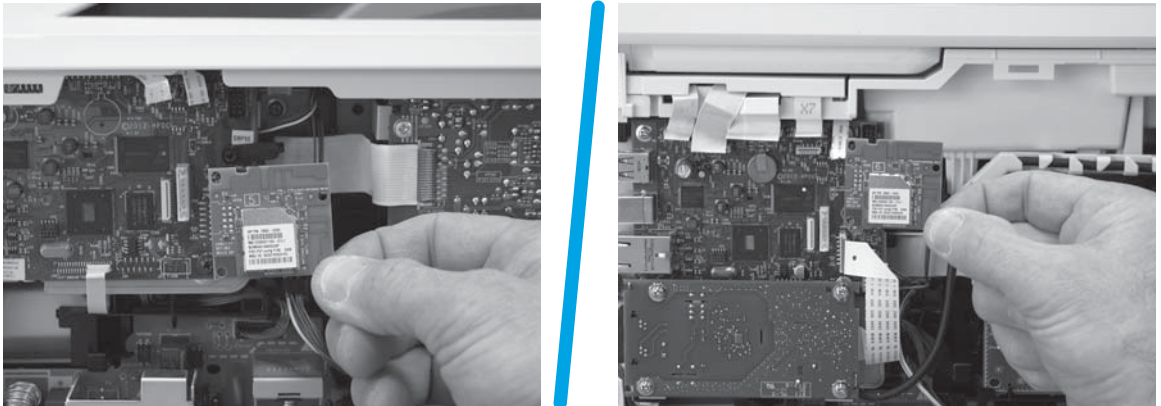

Step 5: Unpack the replacement assembly

Unpack the replacement part from the packaging.

<http://www8.hp.com/us/en/hp-information/environment/product-recycling.html>

 **NOTE:** HP recommends responsible disposal of the defective part.

Figure 1-841 Recycle and unpack

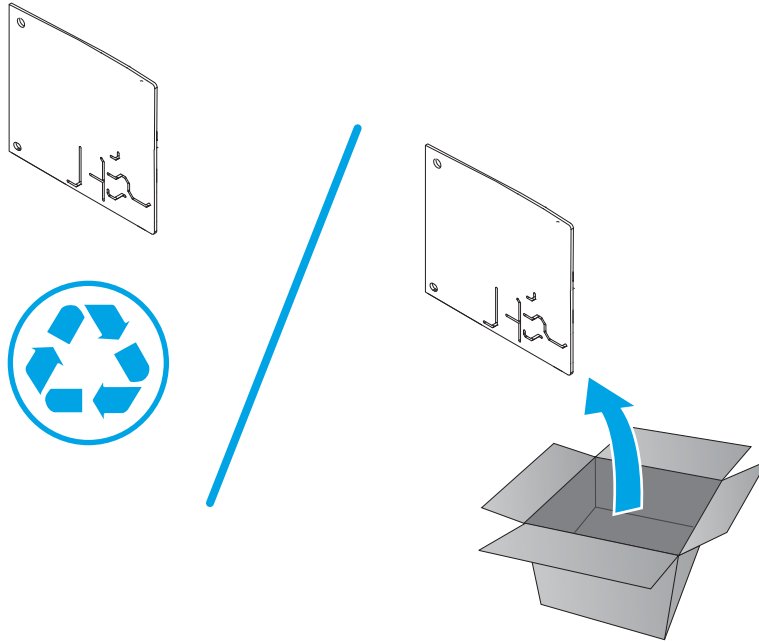

Step 6: Install the wireless PCA

1. Carefully push the wireless PCA straight onto the formatter PCA to install it.

Figure 1-842 Install the PCA

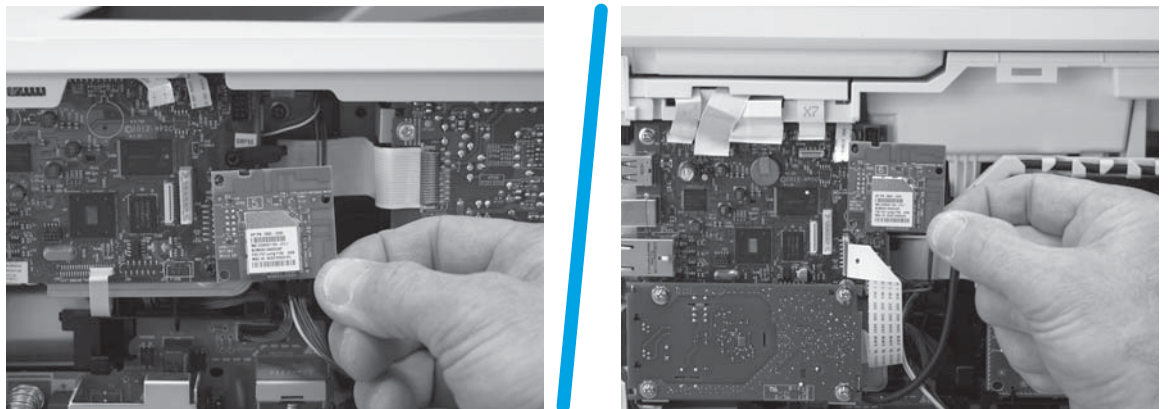

2. Install one screw (callout 1).

Figure 1-843 Install one screw

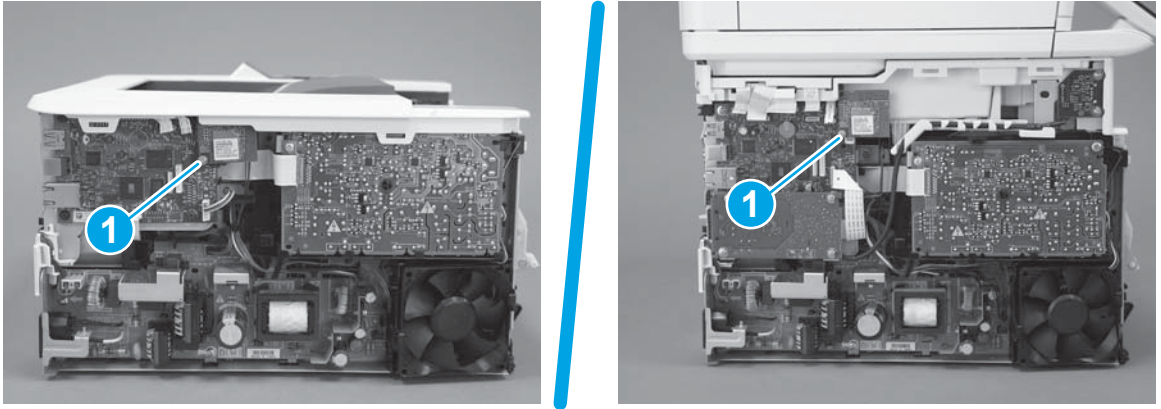

Step 7: Install the left cover

1. At the front of the printer, do one of the following:
 - **M403/M402:** Position the cover on the printer (callout 1), and then engage two bosses (callout 2).
 - **M427/M426:** Position the cover on the printer (callout 3), engage one tab (callout 4), and then engage two bosses (callout 4).

Figure 1-844 Install the cover

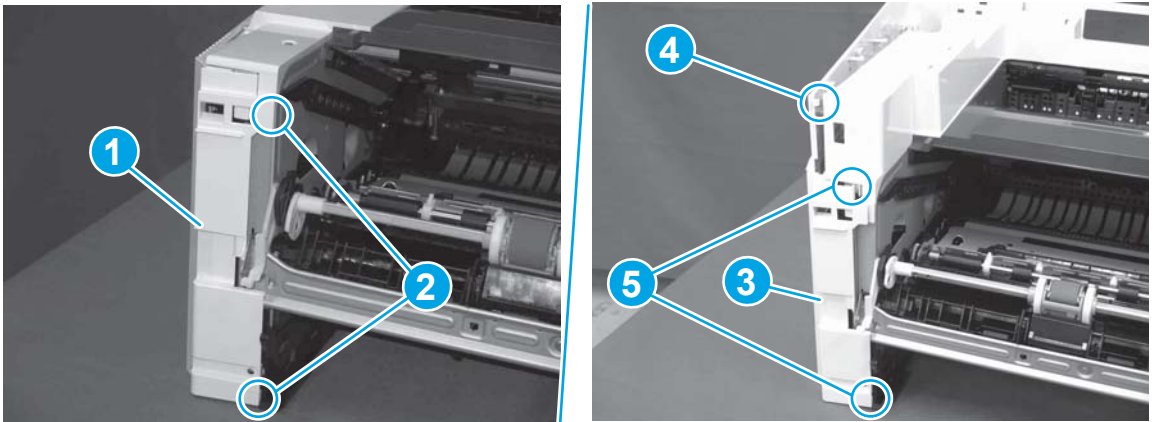

- Carefully rotate the rear of the cover onto the printer (callout 1), engage three tabs (callout 2), and then engage two bosses (callout 3).

Figure 1-845 Engage three tabs and two bosses

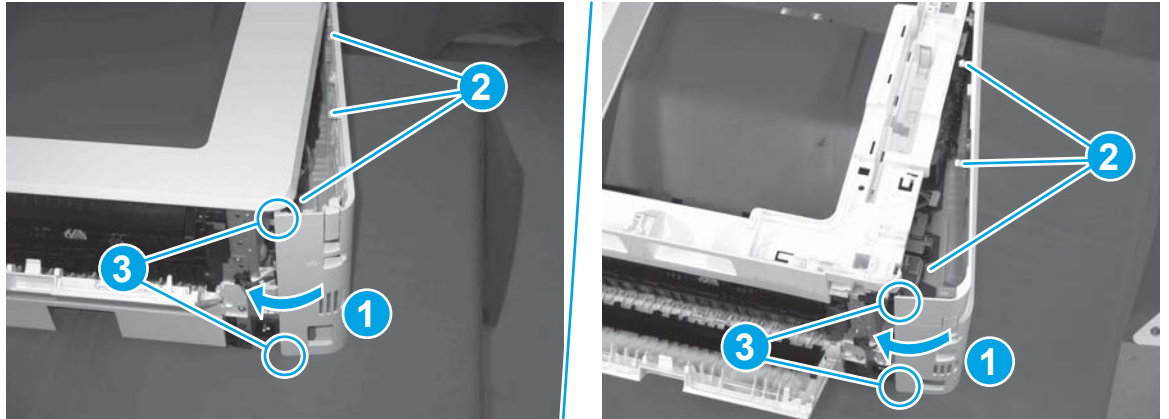

- Install one screw (callout 1).

Figure 1-846 Install one screw

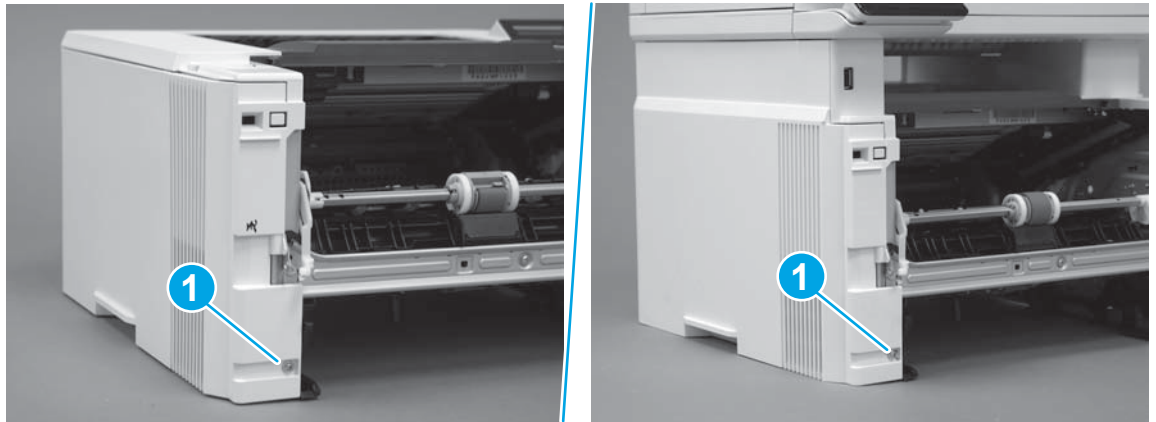

Step 8: Install the cartridge door assembly

 **Reinstallation tip:** After a replacement door is installed, make sure to install the nameplate (supplied in the kit) corresponding to the printer name on the door.

- Position the door close to the printer, and then engage the keyed pin on the left-side retainer arm with the hole in the door.

Figure 1-847 Engage the left-side retainer arm

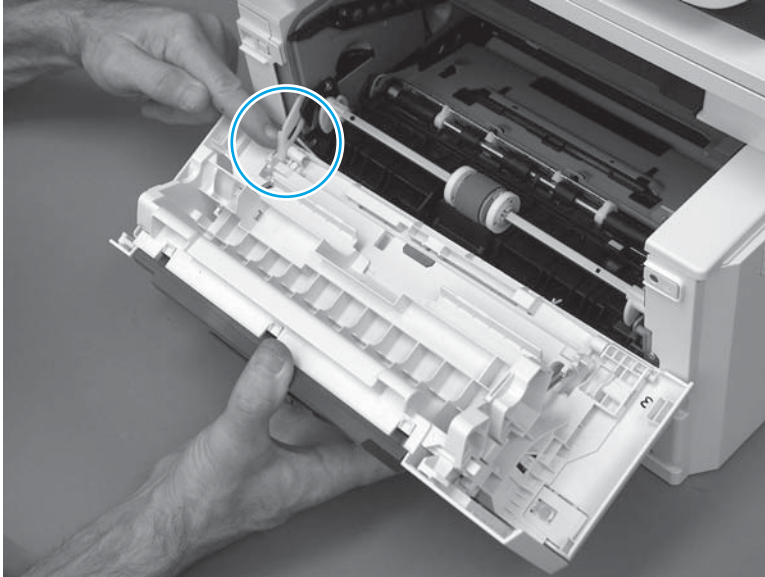

2. Engage the right-side door hinge pin with the hole in the chassis (callout 1).

Figure 1-848 Install the door

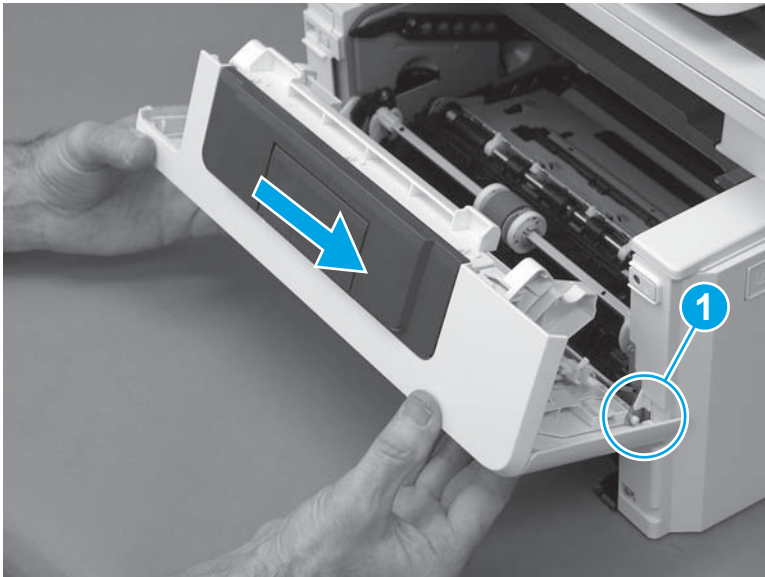

3. Install the link (callout 1).

 **IMPORTANT:** Make sure that the link snaps into place on the arm (callout 2). The link actuates the fuser pressure-release mechanism.

Figure 1-849 Install the pressure-release link

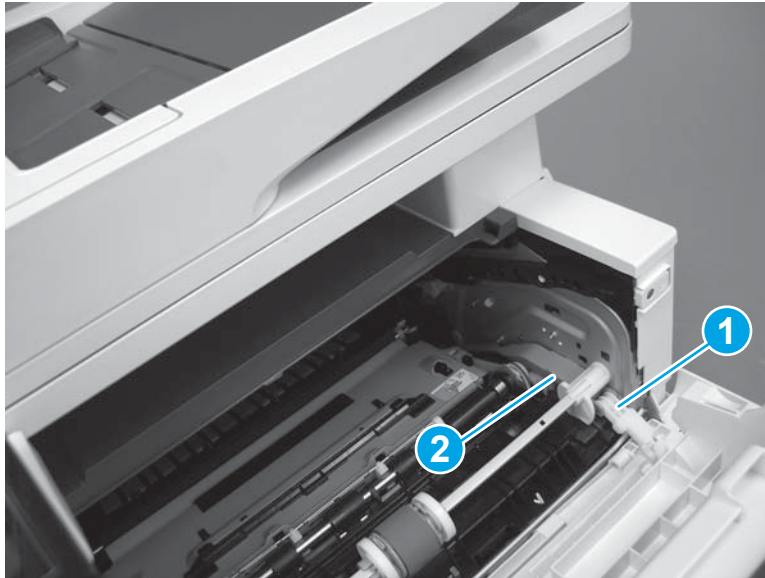

4. Slide the guide into the printer (callout 1), and then make sure that the tab (callout 2) snaps into place to secure the guide to the chassis.

Figure 1-850 Install the guide

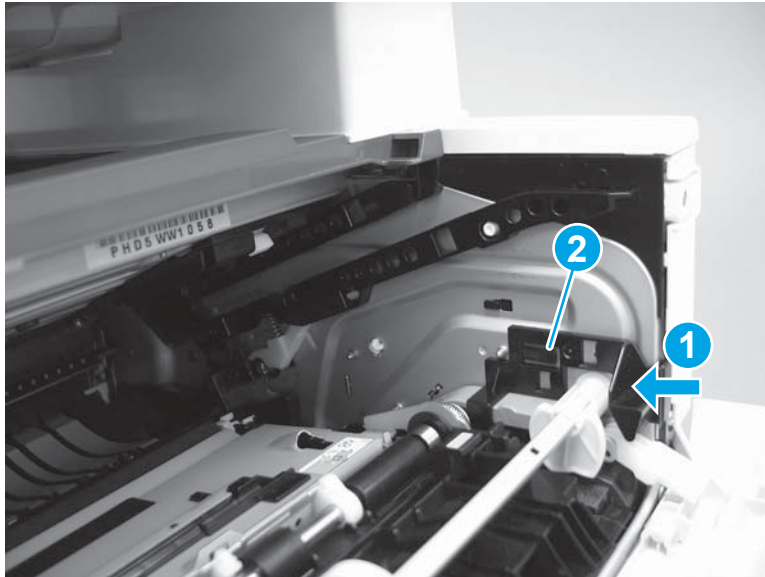

5. Position the shaft on the door, and then align the left-side hinge on the door with the hole in the chassis (callout 1).

Figure 1-851 Align the hinge

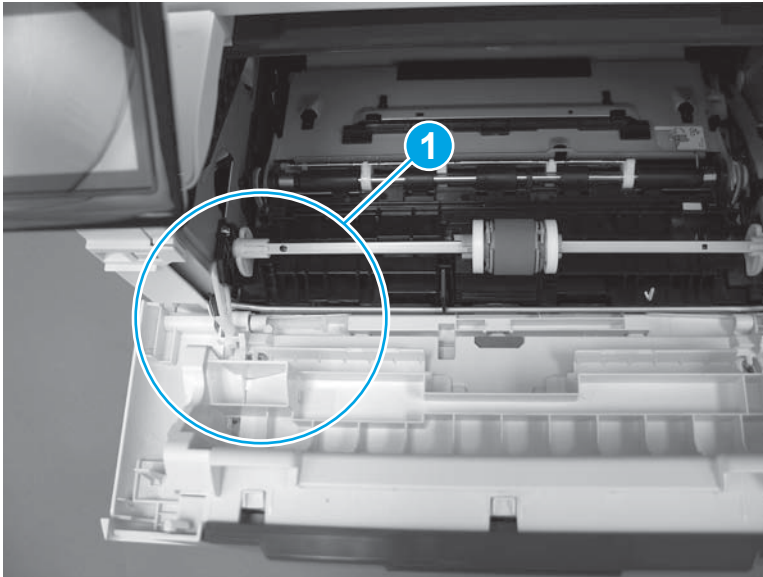

6. Push the shaft towards the left side of the printer to install it (callout 1).

 **Reinstallation tip:** Make sure that the support shaft is fully installed and correctly orientated (callout 2) so that it will not interfere with the door opening and closing.

Figure 1-852 Install the support shaft



Step 9: Install Tray 2

- ▲ Slide the tray straight into the printer to install it.

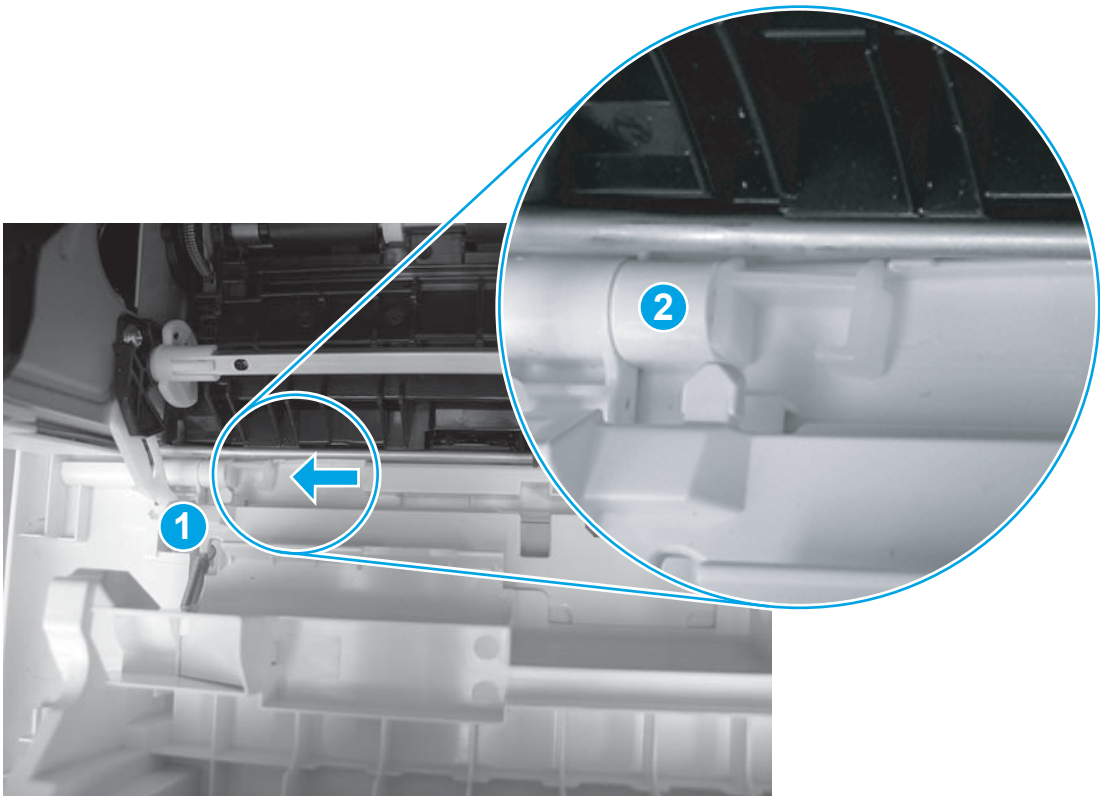
Figure 1-853 Install the tray



Removal and replacement: Formatter PCA

- [Introduction](#)
- [Step 1: Remove Tray 2](#)
- [Step 2: Remove the cartridge door assembly](#)
- [Step 3: Remove the left cover](#)
- [Step 4: Remove the fax PCA](#)
- [Step 5: Remove the wireless PCA](#)
- [Step 6: Remove the formatter PCA](#)
- [Step 7: Unpack the replacement assembly](#)
- [Step 8: Install the formatter PCA](#)
- [Step 9: Install the wireless PCA](#)
- [Step 10: Install the fax PCA](#)
- [Step 11: Install the left cover](#)
- [Step 12: Install the cartridge door assembly](#)
- [Step 13: Install Tray 2](#)

Introduction

This document provides the procedures to remove and replace the formatter PCA.

Before performing service

Turn the printer power off

- Disconnect the power cable.

 **WARNING!** To avoid damage to the printer, turn the printer off, wait 30 seconds, and then remove the power cable before attempting to service the printer.



IMPORTANT: Always replace the thermal transfer pad (5851-6550) when the formatter is replaced.

Formatter PCA part numbers

C5F99-60001	Formatter PCA (M426dw; M427dw)
C5F98-60001	Formatter PCA (M426fdn; M426fdw; M427fdn; M427fdw)
C5F92-60001	Formatter PCA (M402d; M403d)
C5F93-60001	Formatter PCA (M402n; M402dn; M403n; M403dn)
C5F94-60001	Formatter PCA (M402dw; M403dw)

Required tools

- #2 Phillips screwdriver with a magnetic tip.
- 5.5 mm (0.22 inch) socket screwdriver.

After performing service

Turn the printer power on

- Connect the power cable.
- Use the power switch to turn the power on.

Post service test

Make sure that the printer initializes to a **Ready** state.

Print a configuration page to make sure that the printer is functioning correctly.

Step 1: Remove Tray 2

- ▲ Pull the tray straight out of the printer to remove it.

Figure 1-854 Remove the tray



Step 2: Remove the cartridge door assembly



NOTE: If the toner cartridge was not removed prior to servicing the printer, remove it now.

1. Release one tab (callout 1), and then slide shaft (callout 2) in the direction the arrow indicates and remove it.



TIP: It might be easier to release the support shaft by using a small flat-blade screwdriver.

Figure 1-855 Release the support shaft

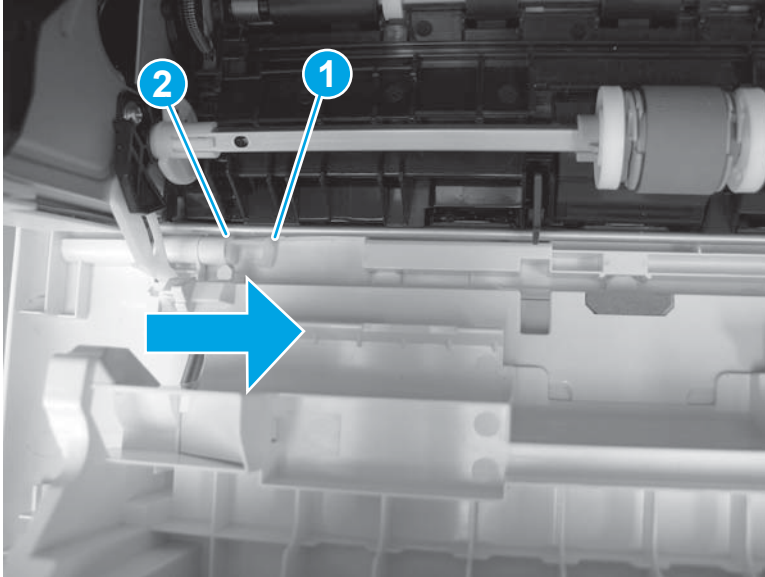

2. Release one tab (callout 1), and then slide the guide (callout 2) in the direction the arrow indicates and remove it.

Figure 1-856 Remove the guide

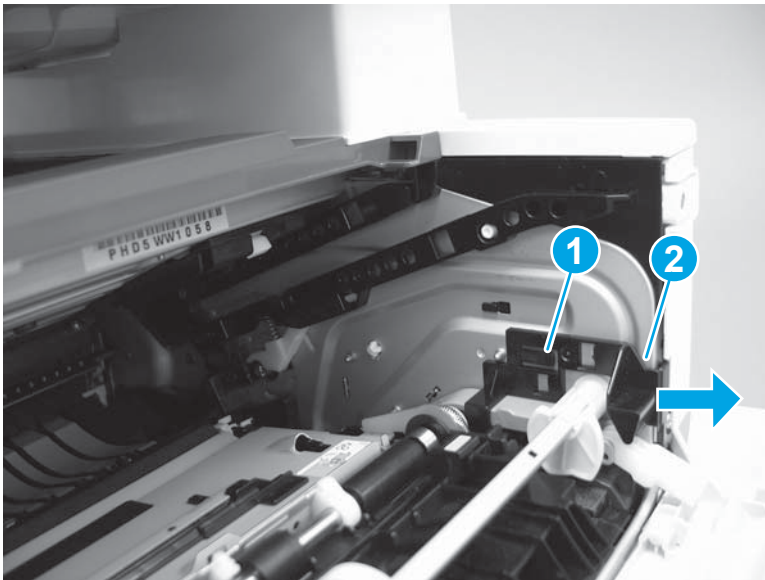

3. Remove the link arm (callout 1).

Figure 1-857 Remove the link arm

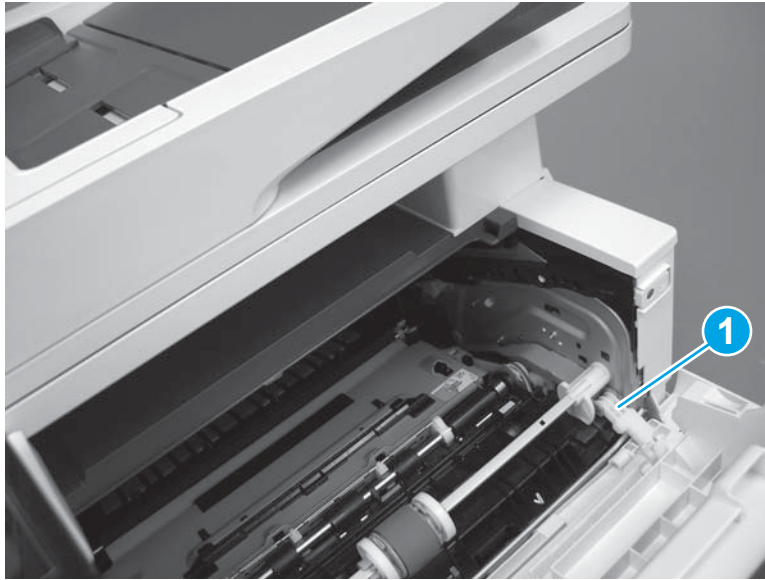

4. Slide the cartridge door assembly (callout 1) in the direction the arrow indicates and remove it.

Figure 1-858 Remove the door

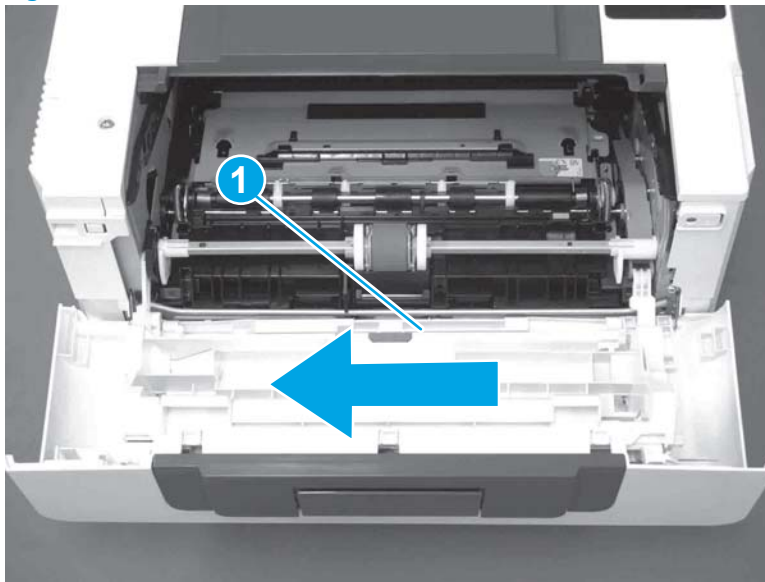

5. Remove the link (callout 1) from the cartridge door assembly (callout 2).

Figure 1-859 Release the left-side retainer arm

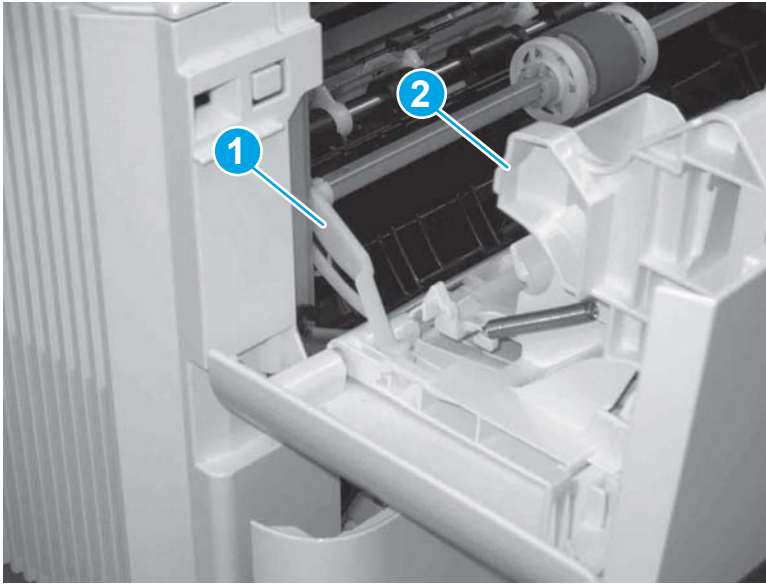

Step 3: Remove the left cover

1. Remove one screw (callout 1).

Figure 1-860 Remove one screw

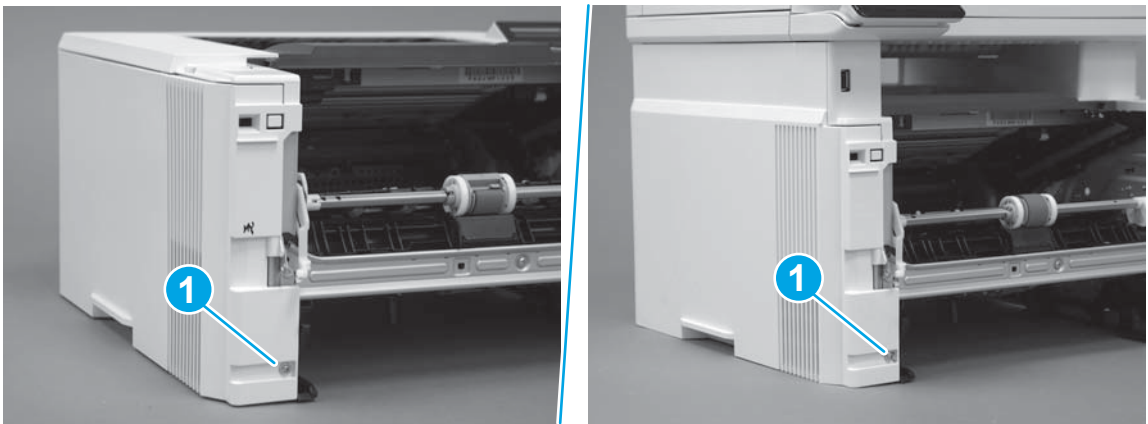

2. Open the rear door, release two bosses (callout 1), and then release three tabs (callout 2).

Figure 1-861 Release two bosses and three tabs

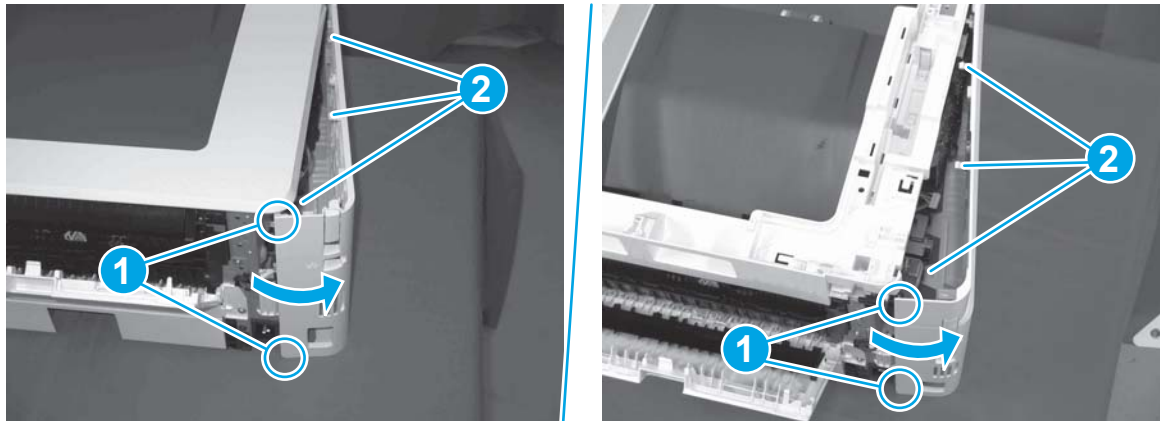

3. At the front of the printer, do one of the following:

- **M403/M402:** Release two bosses (callout 1), and then remove the cover (callout 2).
- **M427/M426:** Release one tab (callout 3), two bosses (callout 4), and then remove the cover (callout 5).

CAUTION: Be careful when releasing the upper bosses on the M427/M426 cover. One portion of the cover (callout 6) is fragile and is easily broken.

Figure 1-862 Remove the cover

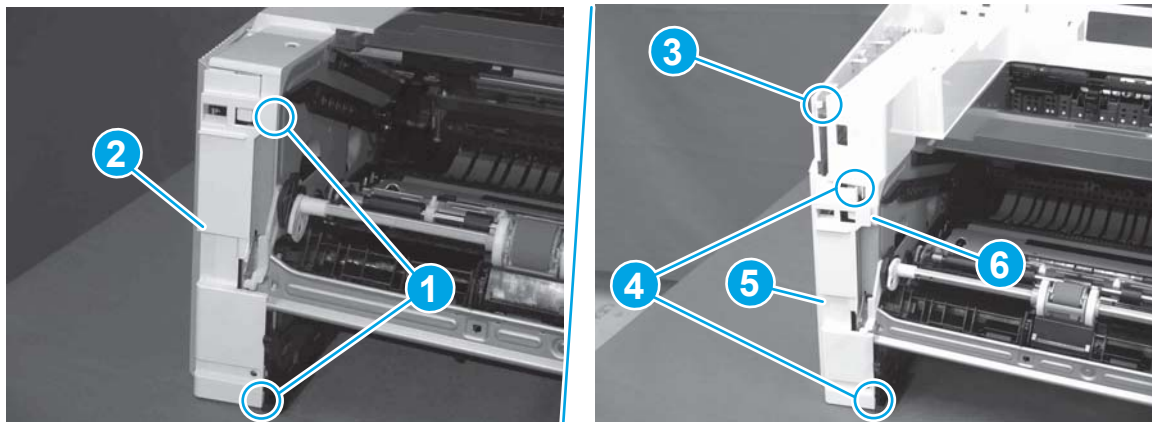

Step 4: Remove the fax PCA

NOTE: Fax models only. For all other models, skip this step and go to [Step 5: Remove the wireless PCA on page 480](#).

1. Remove four screws (callout 1).

Figure 1-863 Remove four screws

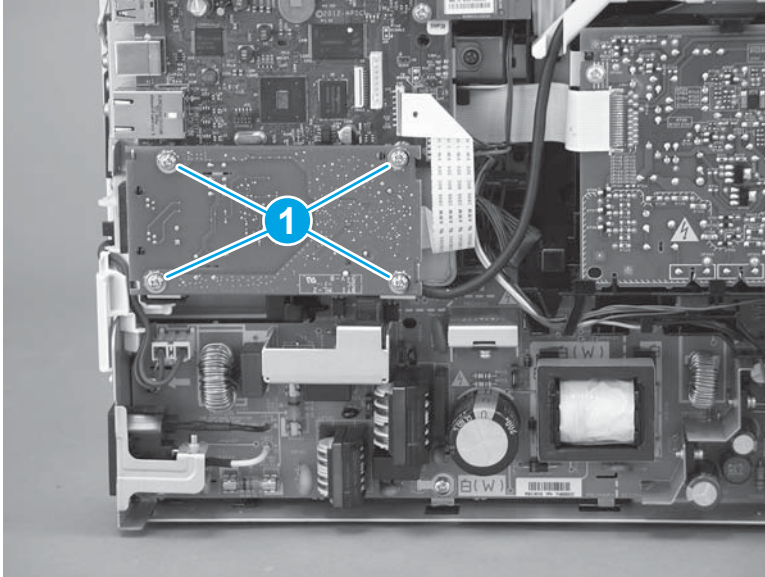

2. Disconnect one FFC (callout 1), and then remove the fax PCA.

Figure 1-864 Disconnect one connector and remove the PCA

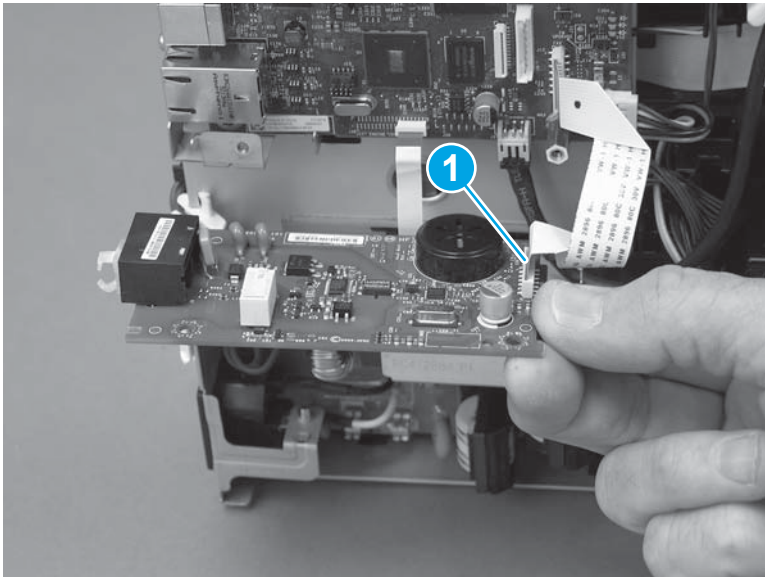

Step 5: Remove the wireless PCA

 **NOTE:** Wireless models only. For all other models, skip this step and go to [Step 6: Remove the formatter PCA on page 481](#).

1. Remove one screw (callout 1).

Figure 1-865 Remove one screw

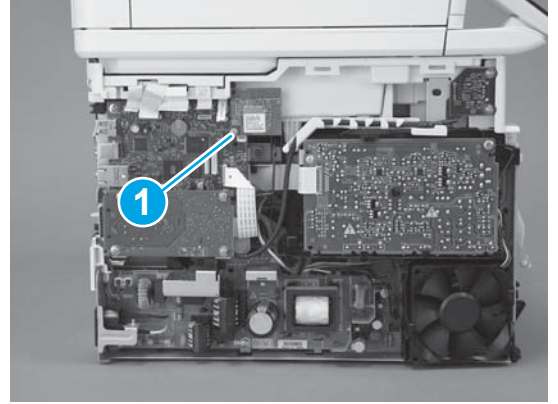
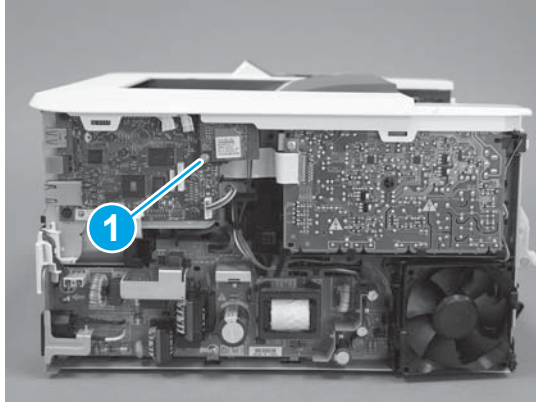

2. Carefully pull the wireless PCA straight off of the formatter PCA to remove it.

Figure 1-866 Remove the wireless PCA

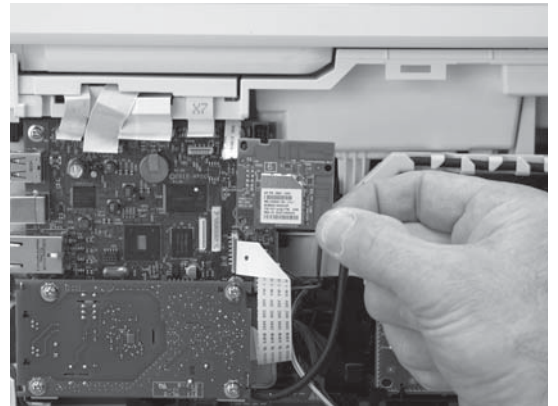
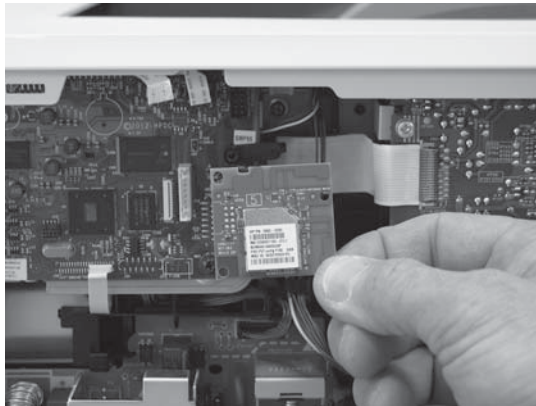

Step 6: Remove the formatter PCA

1. Disconnect all of the connectors and FFCs.

Depending on the M427/M426 model, the following connector locations are empty.

- J6; all models
- J7; all models
- J30; non-wireless models
- J12; non-fax models
- J15; all models
- J17; non-NFC models
- J28; all models

Depending on the M403/M402 model, the following connector locations are empty.

- J6; all models
- J7; all models
- J8; non-wireless models
- J15; all models
- J17; non-NFC models

Figure 1-867 Disconnect all of the connectors and FFCs

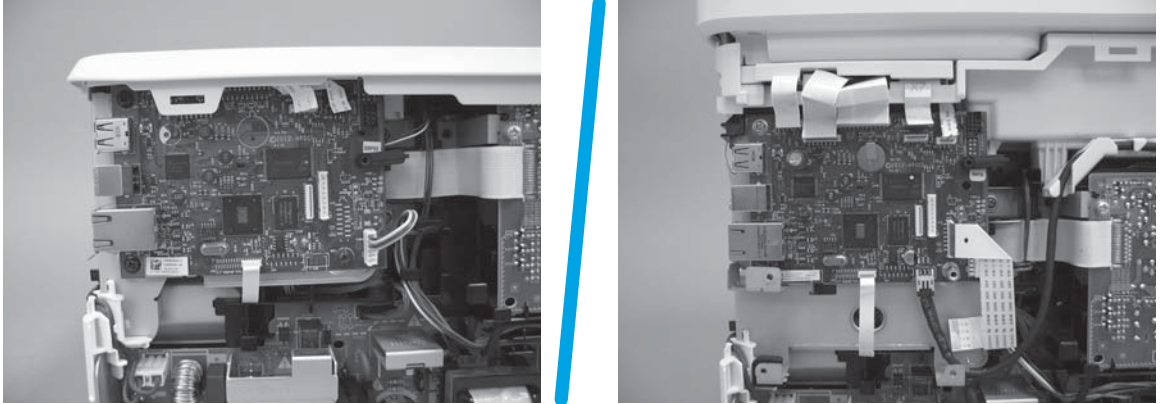

- 2. M427/M426 fax models only:** Remove one screw (callout 1), and then remove the fax PCA support bracket (callout 2).

Figure 1-868 Remove the fax PCA support bracket

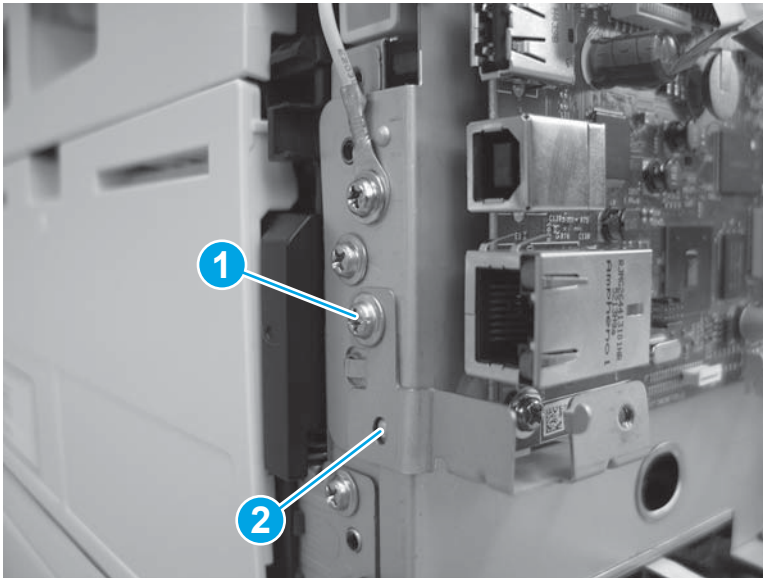

- 3. Do one of the following:**

- **M426/M427:** Remove three screws (callout 1), remove one standoff (callout 2), and then remove the formatter PCA.

 **NOTE:** Use a 5.5 mm (0.22 inch) socket screwdriver to remove the standoff (callout 2).

- **M403/M402:** Remove four screws (callout 1), and then remove the formatter PCA.

 **Reinstallation tip:** If a replacement formatter will be installed and the printer is a wireless model, make sure that the wireless PCA mounting holder (B3Q10-40054; callout 3) is transferred to the replacement formatter.

Figure 1-869 Remove the formatter PCA



Step 7: Unpack the replacement assembly

Unpack the replacement part from the packaging.

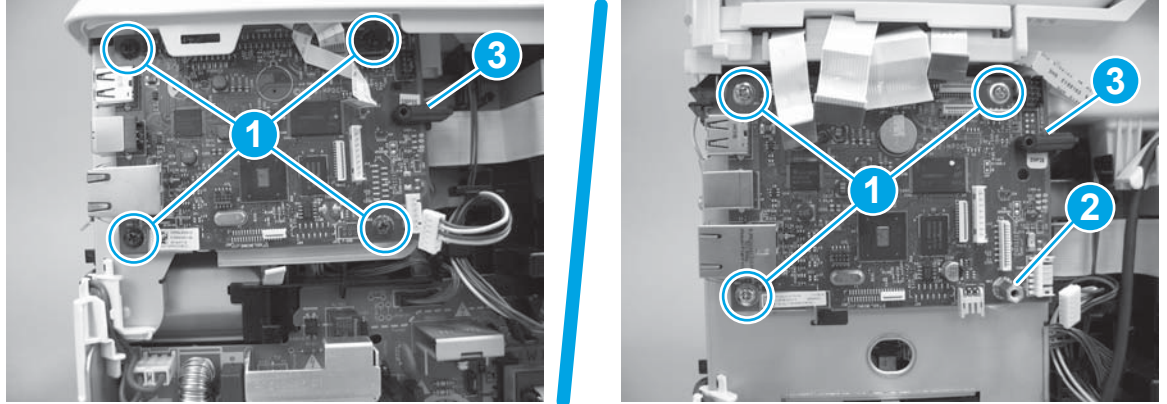
<http://www8.hp.com/us/en/hp-information/environment/product-recycling.html>

 **NOTE:** HP recommends responsible disposal of the defective part.

Figure 1-870 Recycle and unpack

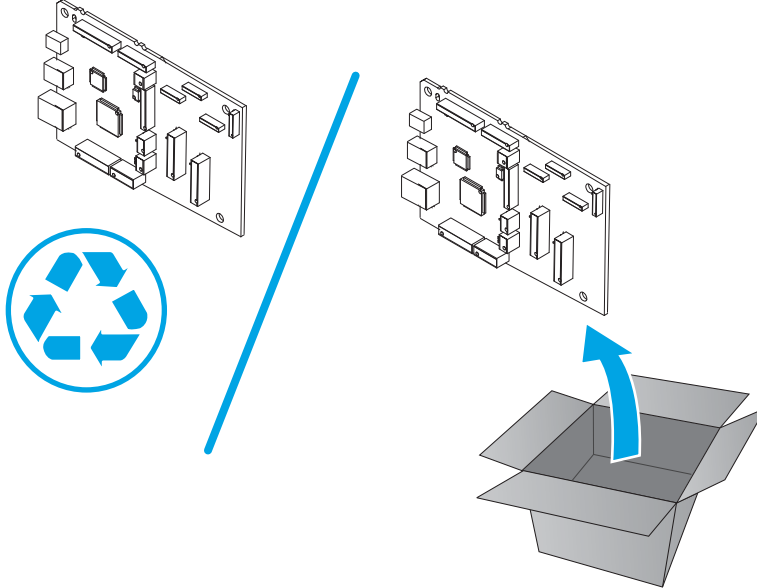

Step 8: Install the formatter PCA

 **NOTE:** If the formatter PCA thermal pad on the back side of the PCA is broken or damaged, replace the pad (5851-6550).

1. Adhere the pad to the sheet-metal bracket (a positioning line is embossed in the bracket).

Do one of the following:

- **M426/M427:** Position the formatter PCA on the printer, install three screws (callout 1), and then install one standoff (callout 2).
- **M403/M402:** Position the formatter PCA on the printer, and then install four screws (callout 1).

 **Reinstallation tip:** If a replacement formatter PCA will be installed and the printer is a wireless model, make sure that the wireless PCA mounting holder (callout 3) is transferred to the replacement formatter PCA.

Figure 1-871 Install the formatter PCA



2. **M427/M426 fax models only:** Position the fax PCA support bracket (callout 1) on the printer, and then install one screw (callout 2).

Figure 1-872 Remove the fax PCA support bracket

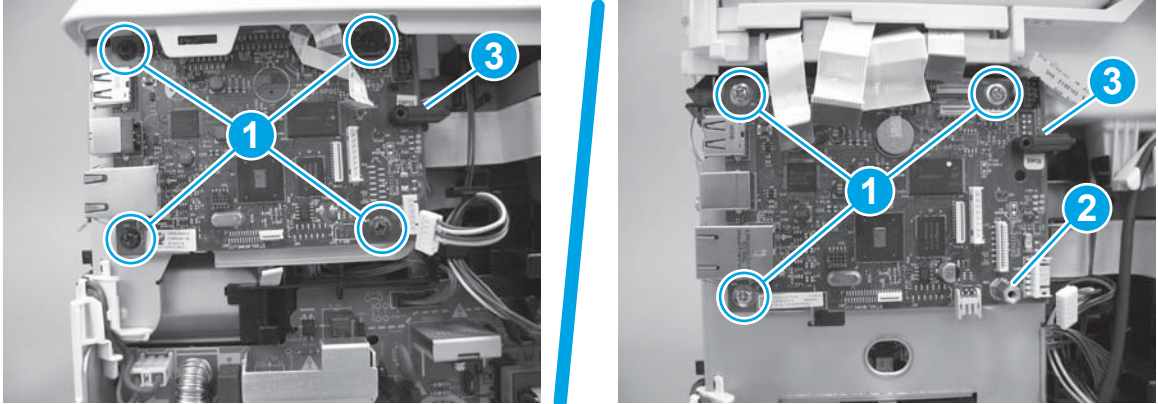
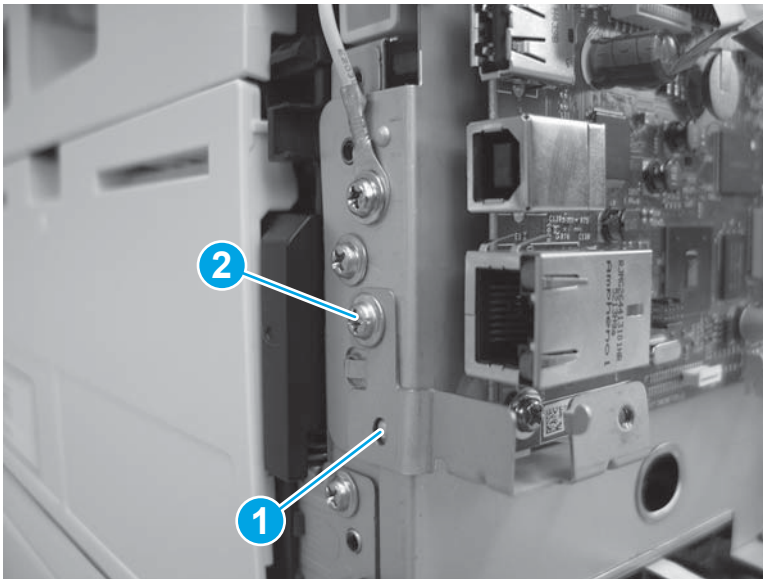

3. Connect all of the connectors and FFCs.

Depending on the M427/M426 model, the following connector locations are empty.

- J6; all models
- J7; all models
- J30; non-wireless models
- J12; non-fax models
- J15; all models
- J17; non-NFC models
- J28; all models

Depending on the M403/M402 model, the following connector locations are empty.

- J6; all models
- J7; all models
- J8; non-wireless models
- J15; all models
- J17; non-NFC models

Figure 1-873 Connect all of the connectors and FFCs

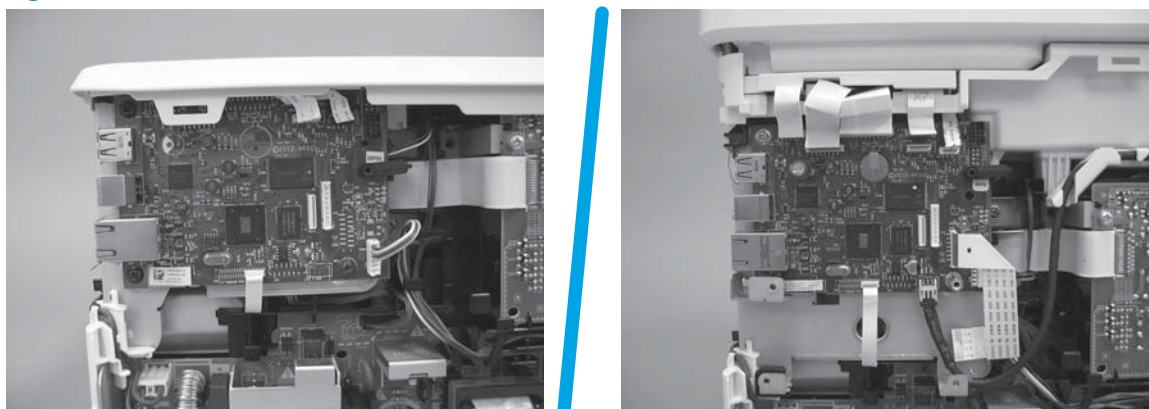

Step 9: Install the wireless PCA

 **NOTE:** Wireless models only. For all other models, skip this step and go to [Step 10: Install the fax PCA on page 486](#).

1. Carefully push the wireless PCA straight onto the formatter PCA to install it.

Figure 1-874 Install the PCA

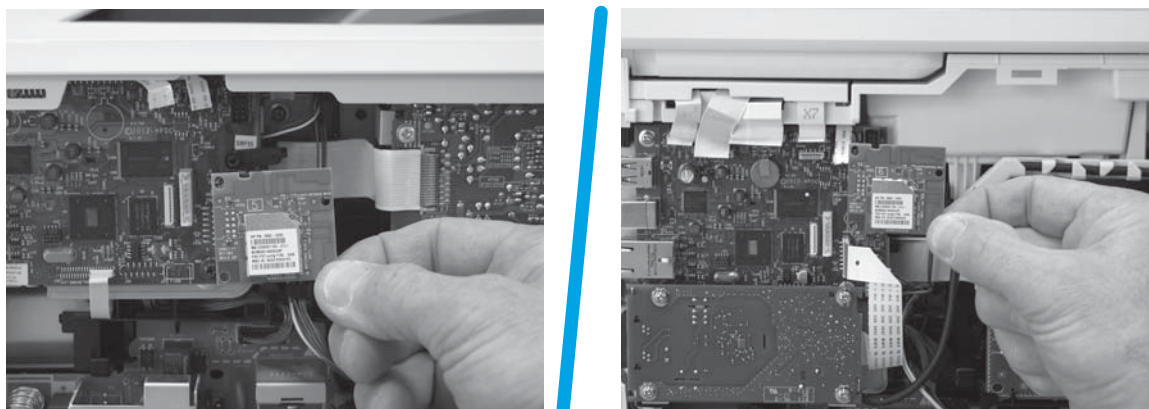

2. Install one screw (callout 1).

Figure 1-875 Install one screw

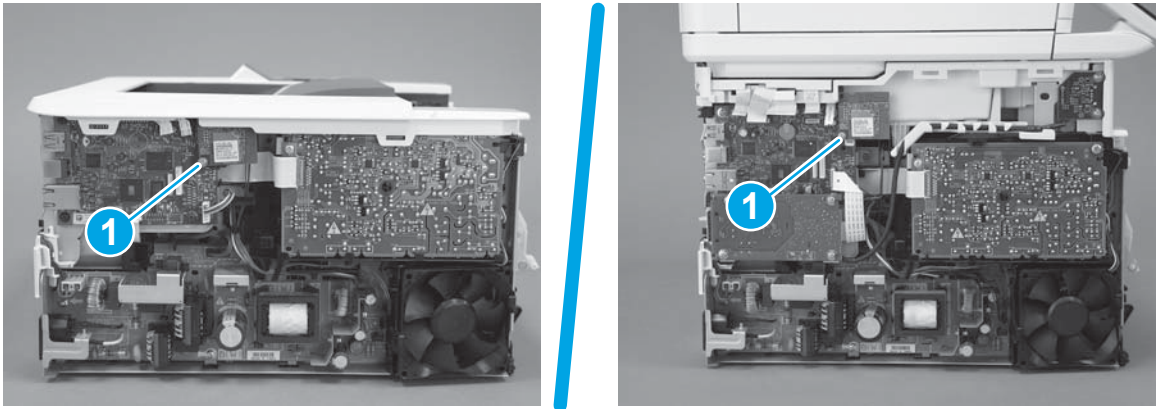

Step 10: Install the fax PCA



NOTE: Fax models only. For all other models, skip this step and go to [Step 11: Install the left cover on page 487](#).

1. Connect one FFC cable (callout 1), and then position the fax PCA on the printer.

Figure 1-876 Connect one connector and install the PCA

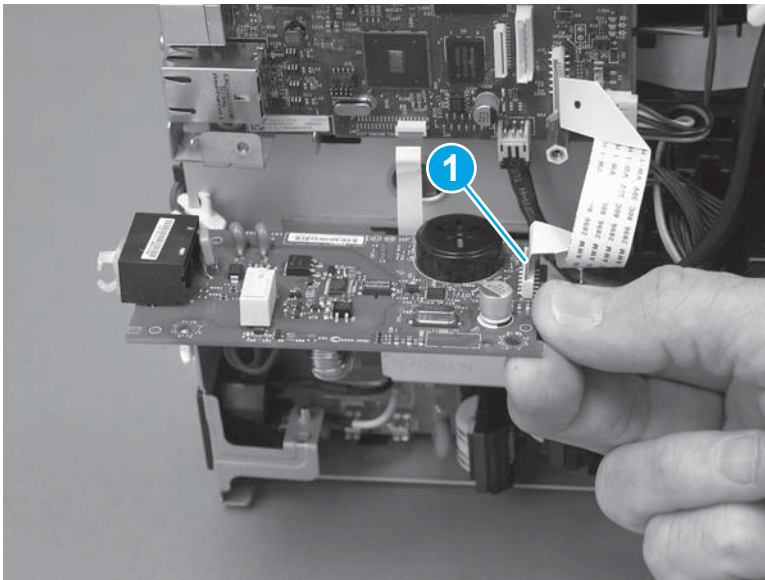

2. Install four screws (callout 1).

Figure 1-877 Install four screws

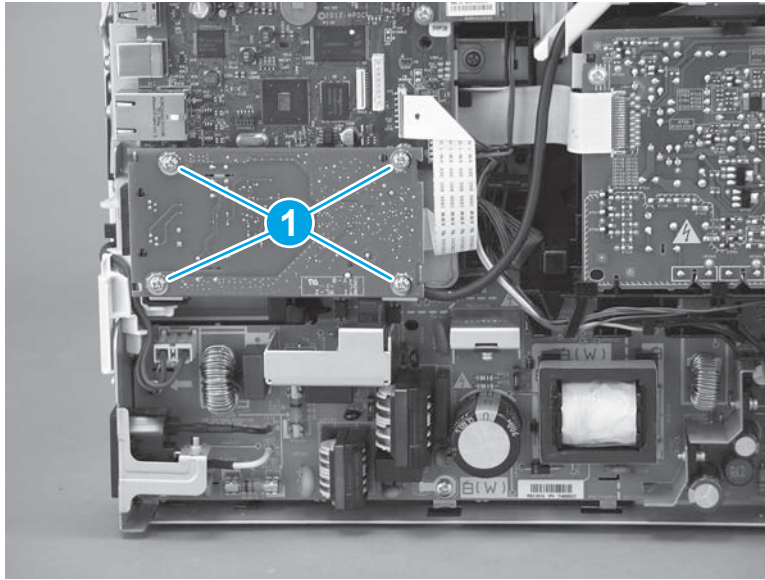

Step 11: Install the left cover

1. At the front of the printer, do one of the following:
 - **M403/M402:** Position the cover on the printer (callout 1), and then engage two bosses (callout 2).
 - **M427/M426:** Position the cover on the printer (callout 3), engage one tab (callout 4), and then engage two bosses (callout 4).

Figure 1-878 Install the cover

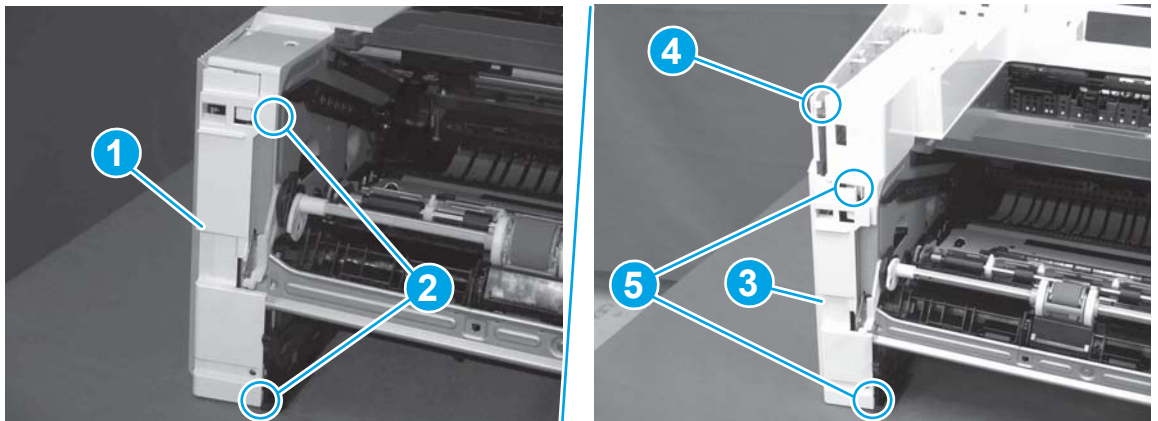

- Carefully rotate the rear of the cover onto the printer (callout 1), engage three tabs (callout 2), and then engage two bosses (callout 3).

Figure 1-879 Engage three tabs and two bosses

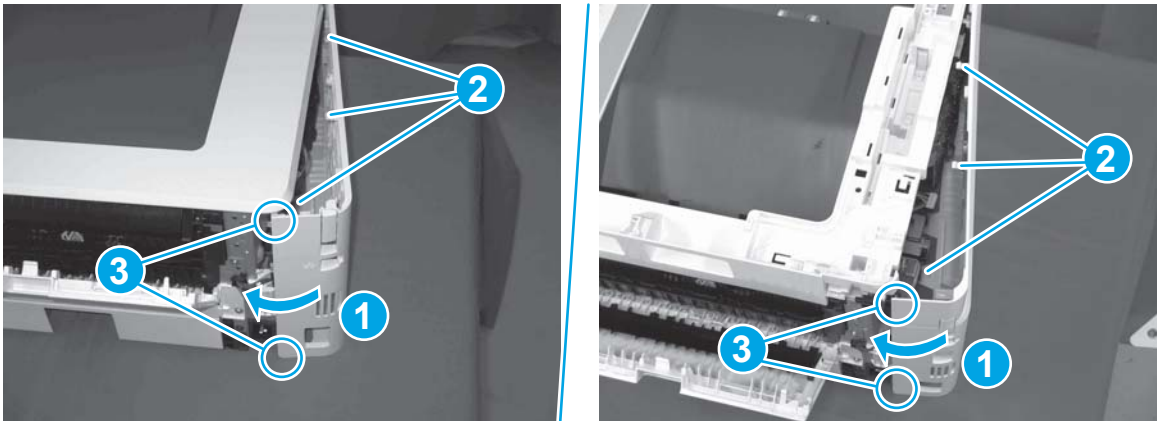

- Install one screw (callout 1).

Figure 1-880 Install one screw

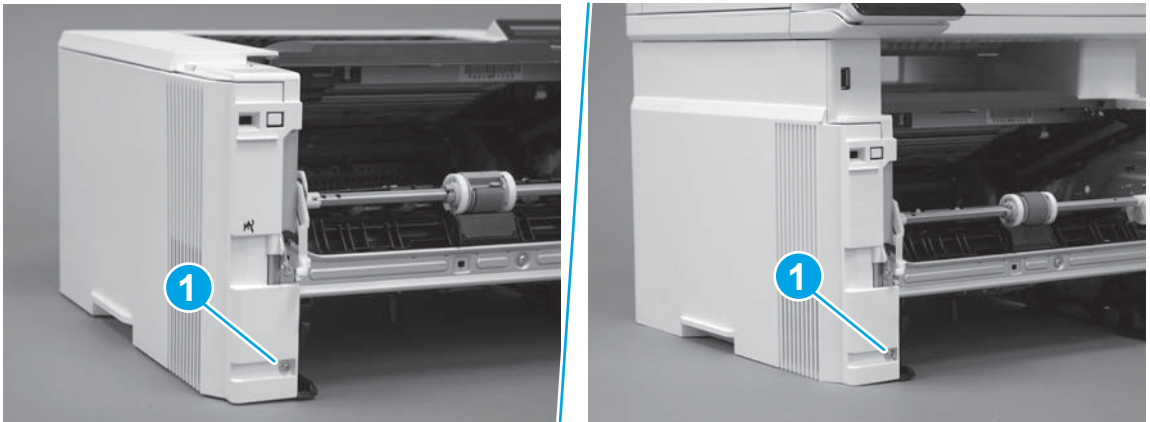

Step 12: Install the cartridge door assembly

 **Reinstallation tip:** After a replacement door is installed, make sure to install the nameplate (supplied in the kit) corresponding to the printer name on the door.

- Position the door close to the printer, and then engage the keyed pin on the left-side retainer arm with the hole in the door.

Figure 1-881 Engage the left-side retainer arm

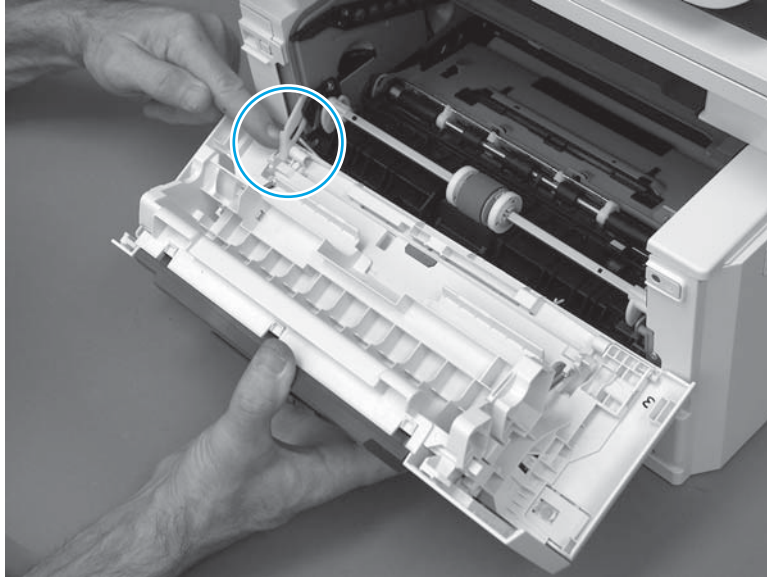

2. Engage the right-side door hinge pin with the hole in the chassis (callout 1).

Figure 1-882 Install the door

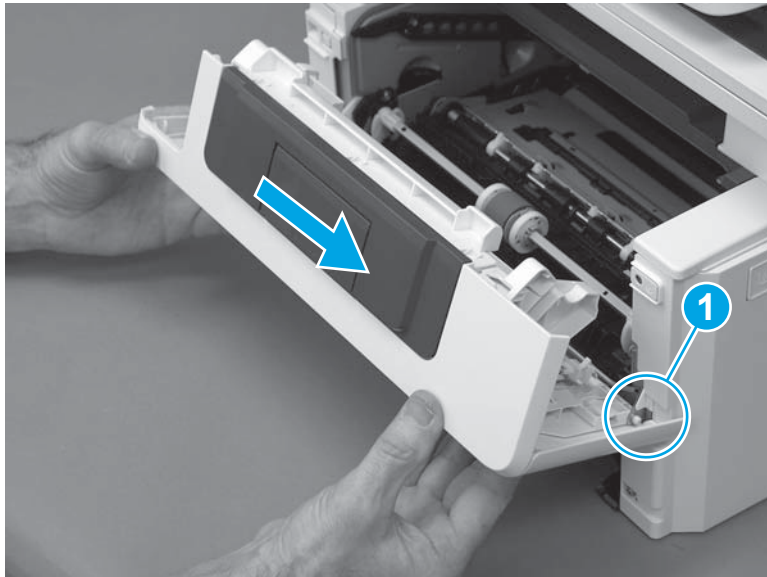

3. Install the link (callout 1).

 **IMPORTANT:** Make sure that the link snaps into place on the arm (callout 2). The link actuates the fuser pressure-release mechanism.

Figure 1-883 Install the pressure-release link

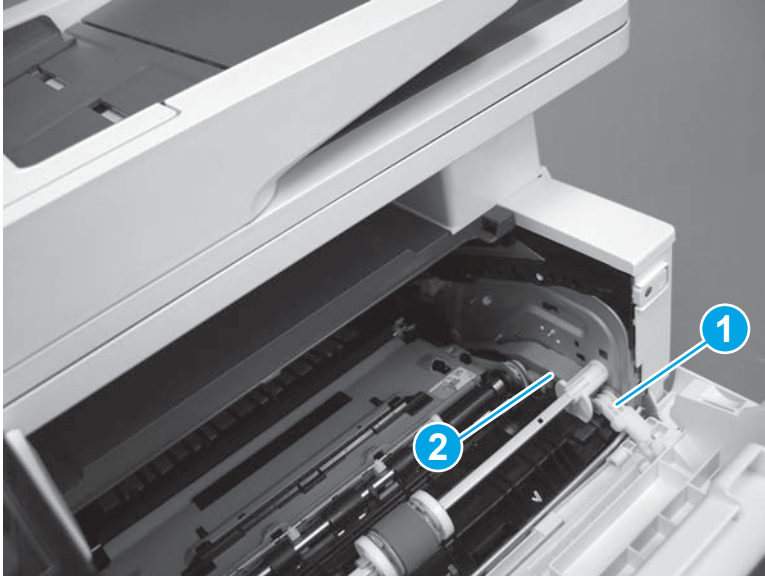

4. Slide the guide into the printer (callout 1), and then make sure that the tab (callout 2) snaps into place to secure the guide to the chassis.

Figure 1-884 Install the guide

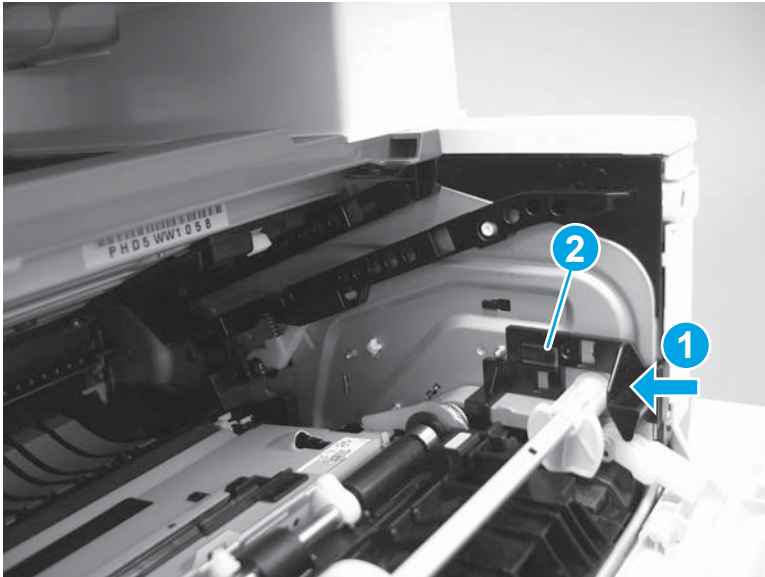

5. Position the shaft on the door, and then align the left-side hinge on the door with the hole in the chassis (callout 1).

Figure 1-885 Align the hinge

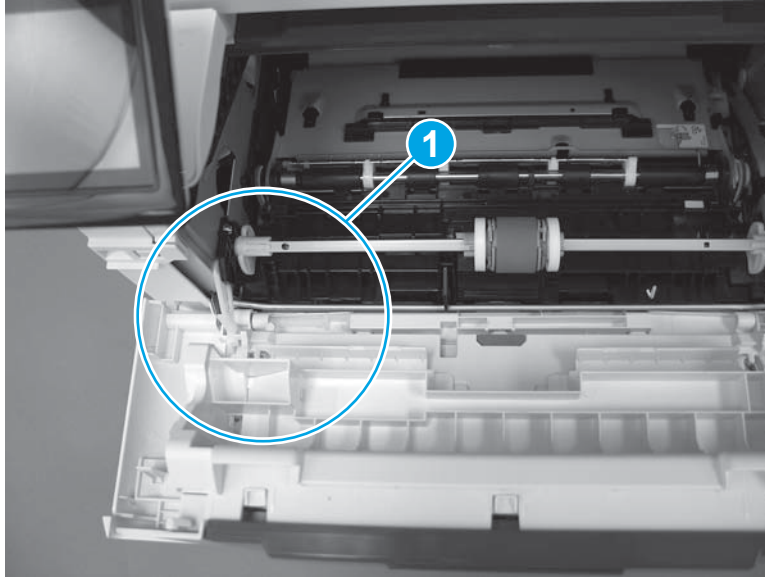

6. Push the shaft towards the left side of the printer to install it (callout 1).

 **Reinstallation tip:** Make sure that the support shaft is fully installed and correctly orientated (callout 2) so that it will not interfere with the door opening and closing.

Figure 1-886 Install the support shaft



Step 13: Install Tray 2

- ▲ Slide the tray straight into the printer to install it.

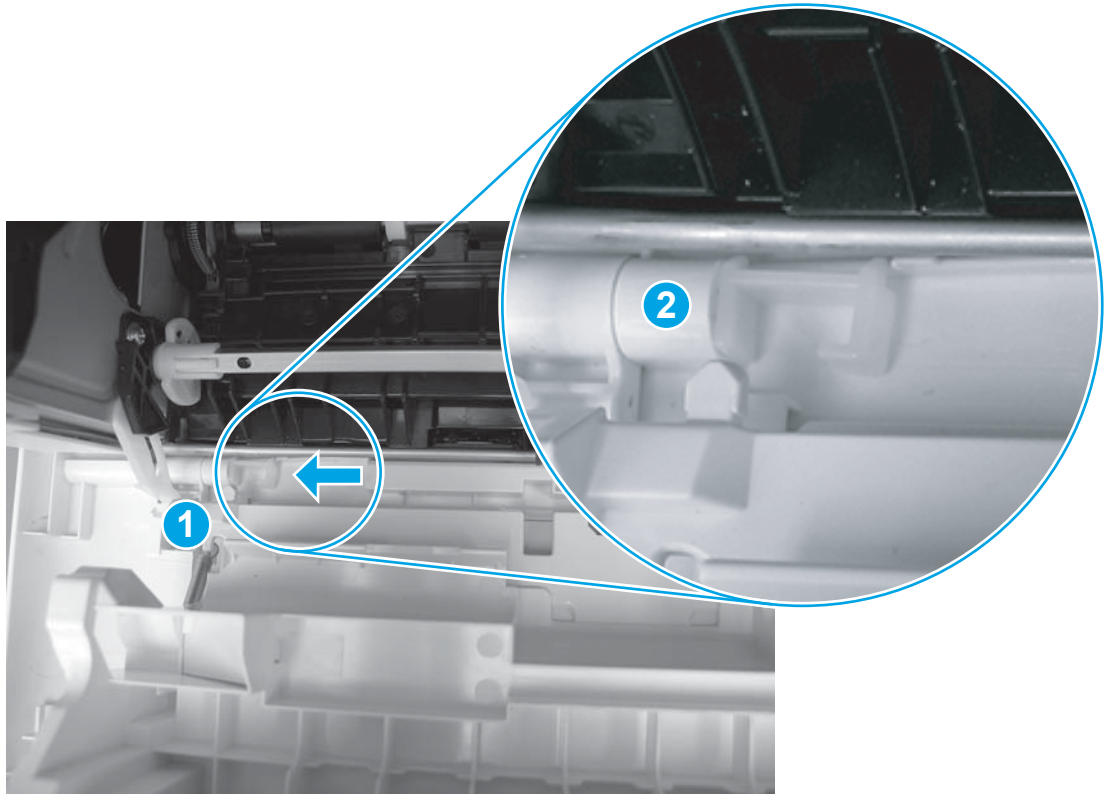
Figure 1-887 Install the tray



Removal and replacement: Fan (FM1)

- [Introduction](#)
- [Step 1: Remove Tray 2](#)
- [Step 2: Remove the cartridge door assembly](#)
- [Step 3: Remove the left cover](#)
- [Step 4: Remove the fan \(FM1\)](#)
- [Step 5: Unpack the replacement assembly](#)
- [Step 6: Install the fan \(FM1\)](#)
- [Step 7: Install the left cover](#)
- [Step 8: Install the cartridge door assembly](#)
- [Step 9: Install Tray 2](#)

Introduction

This document provides the procedures to remove and replace the fan (FM1).

Before performing service

Turn the printer power off

- Disconnect the power cable.

 **WARNING!** To avoid damage to the printer, turn the printer off, wait 30 seconds, and then remove the power cable before attempting to service the printer.

Use the table below to identify the correct part number for your printer. To order the part, go to www.hp.com/buy/parts.

Fan (FM1) part number	
RK2-8068-000CN	Fan (FM1)

Required tools

- #2 Phillips screwdriver with a magnetic tip.

After performing service

Turn the printer power on

- Connect the power cable.
- Use the power switch to turn the power on.

Post service test

Listen for the fan to rotate when the printer power is turned on.

Step 1: Remove Tray 2

- ▲ Pull the tray straight out of the printer to remove it.

Figure 1-888 Remove the tray



Step 2: Remove the cartridge door assembly

 **NOTE:** If the toner cartridge was not removed prior to servicing the printer, remove it now.

1. Release one tab (callout 1), and then slide shaft (callout 2) in the direction the arrow indicates and remove it.

 **TIP:** It might be easier to release the support shaft by using a small flat-blade screwdriver.

Figure 1-889 Release the support shaft

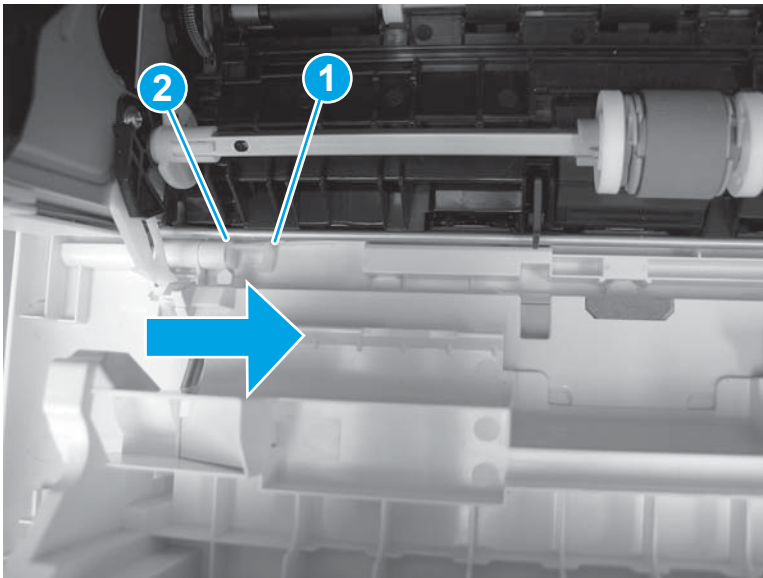

2. Release one tab (callout 1), and then slide the guide (callout 2) in the direction the arrow indicates and remove it.

Figure 1-890 Remove the guide

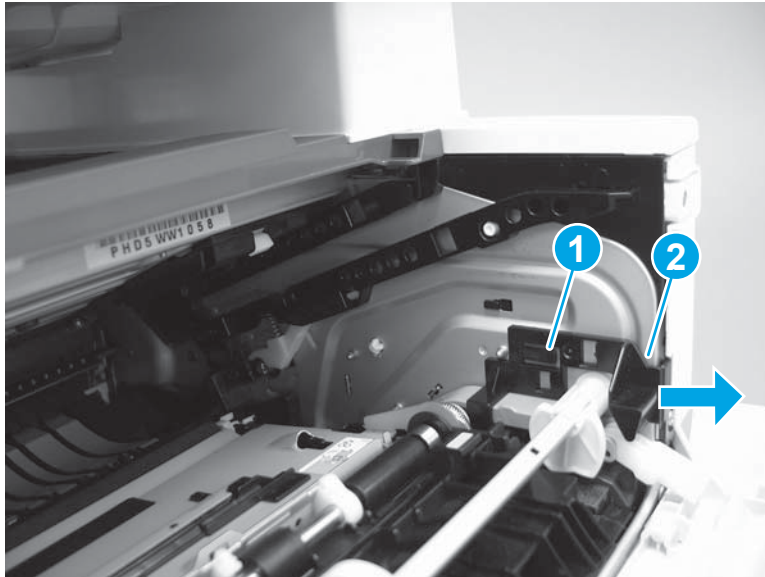

3. Remove the link arm (callout 1).

Figure 1-891 Remove the link arm

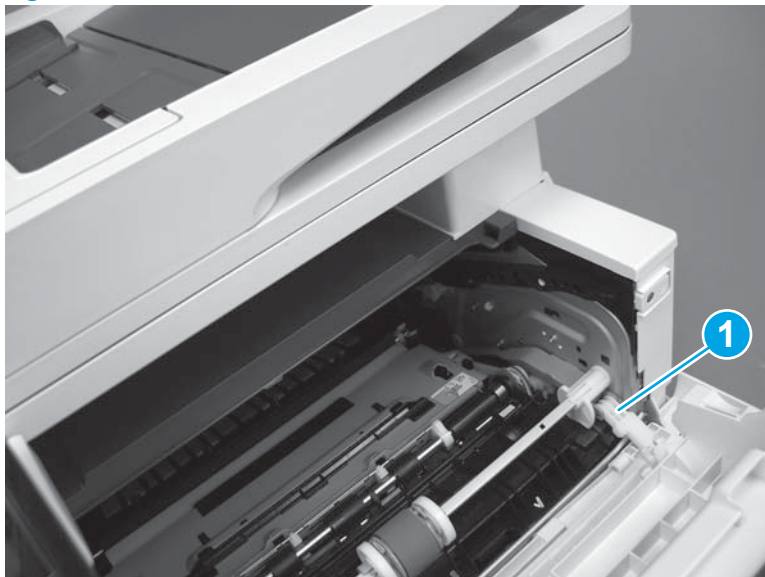

4. Slide the cartridge door assembly (callout 1) in the direction the arrow indicates and remove it.

Figure 1-892 Remove the door

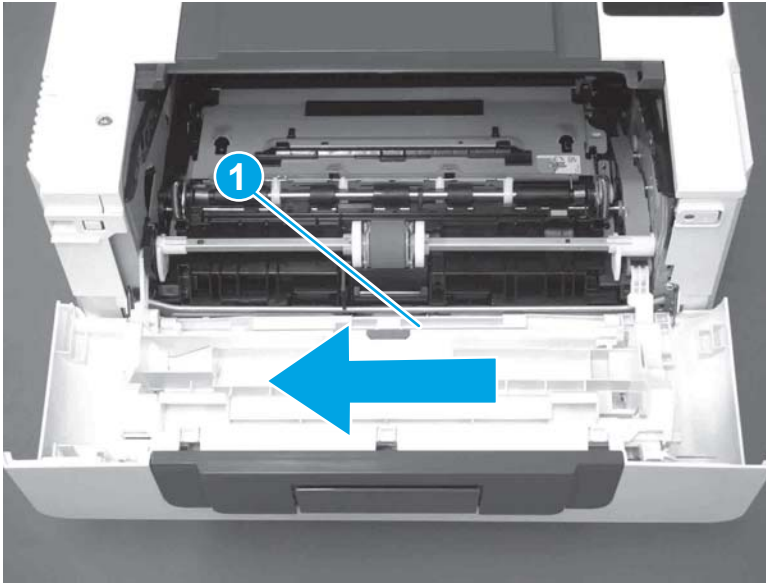

5. Remove the link (callout 1) from the cartridge door assembly (callout 2).

Figure 1-893 Release the left-side retainer arm

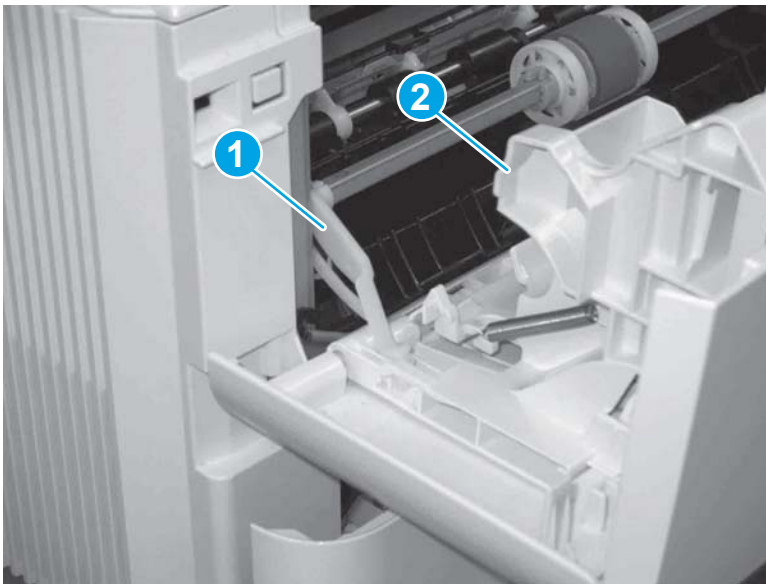

Step 3: Remove the left cover

1. Remove one screw (callout 1).

Figure 1-894 Remove one screw

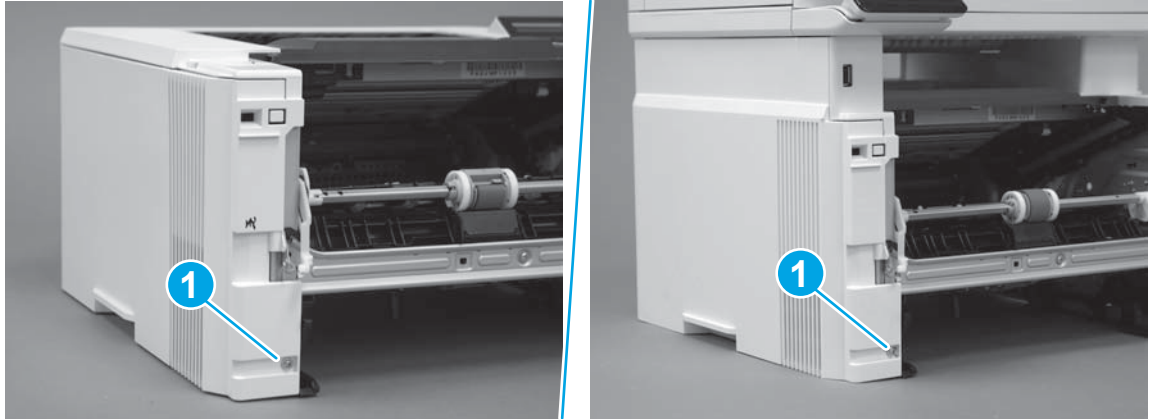

2. Open the rear door, release two bosses (callout 1), and then release three tabs (callout 2).

Figure 1-895 Release two bosses and three tabs

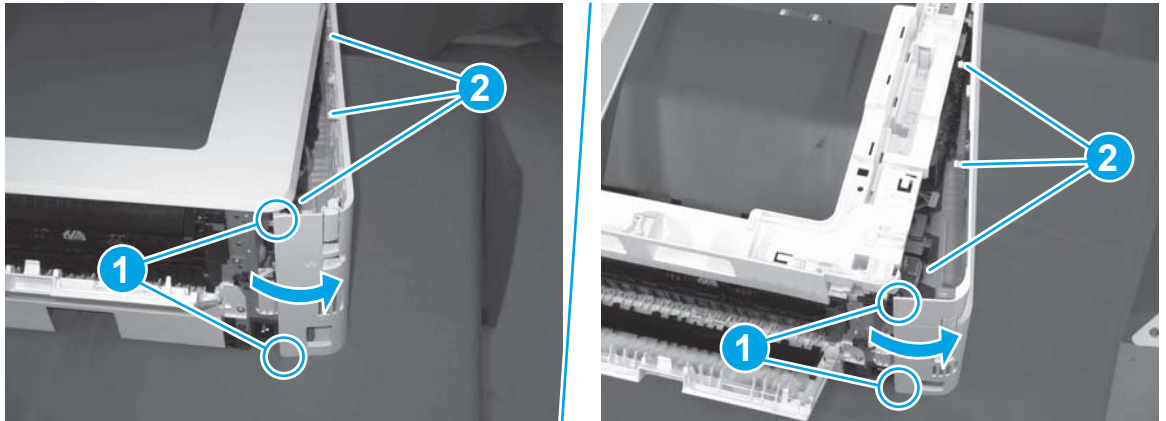

3. At the front of the printer, do one of the following:

- **M403/M402:** Release two bosses (callout 1), and then remove the cover (callout 2).
- **M427/M426:** Release one tab (callout 3), two bosses (callout 4), and then remove the cover (callout 5).

CAUTION: Be careful when releasing the upper bosses on the M427/M426 cover. One portion of the cover (callout 6) is fragile and is easily broken.

Figure 1-896 Remove the cover

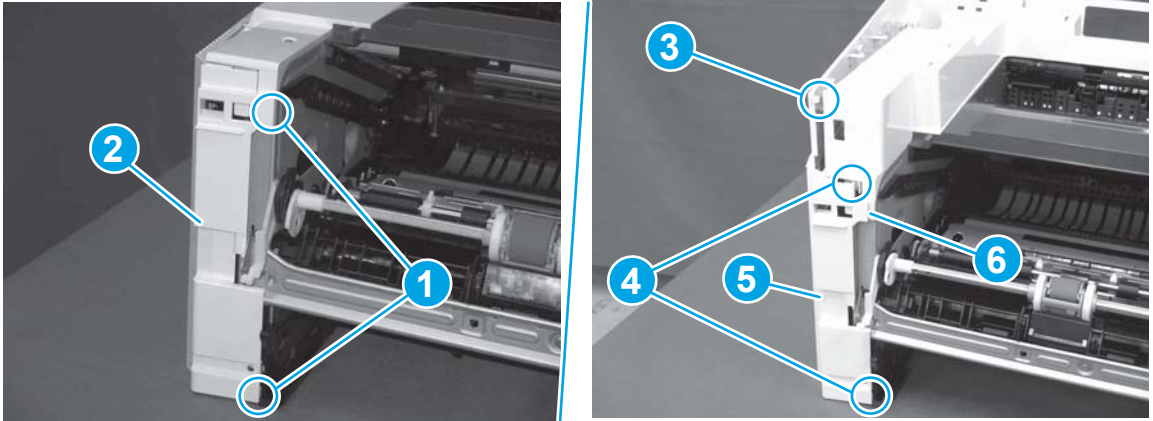

Step 4: Remove the fan (FM1)

1. Disconnect one connector (callout 1), and then release the wire harness from the retainer (callout 2).

Figure 1-897 Disconnect one connector

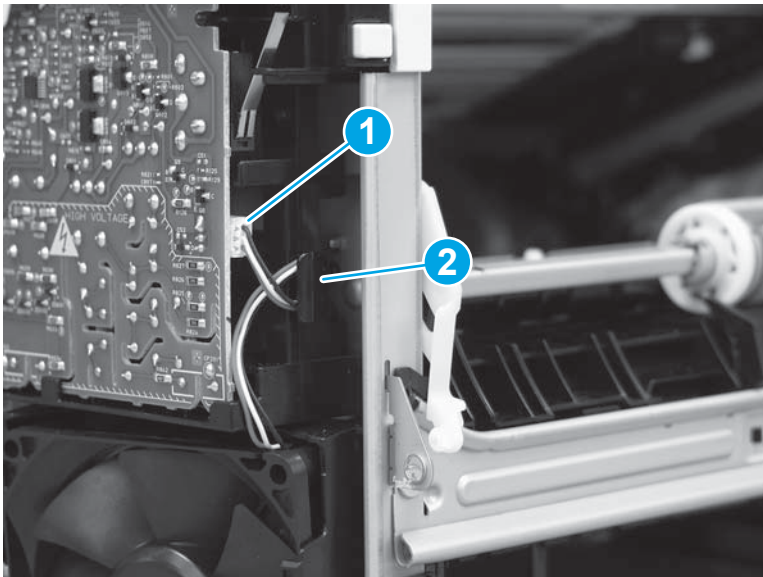

2. Release two tabs (callout 1).

Figure 1-898 Release two tabs

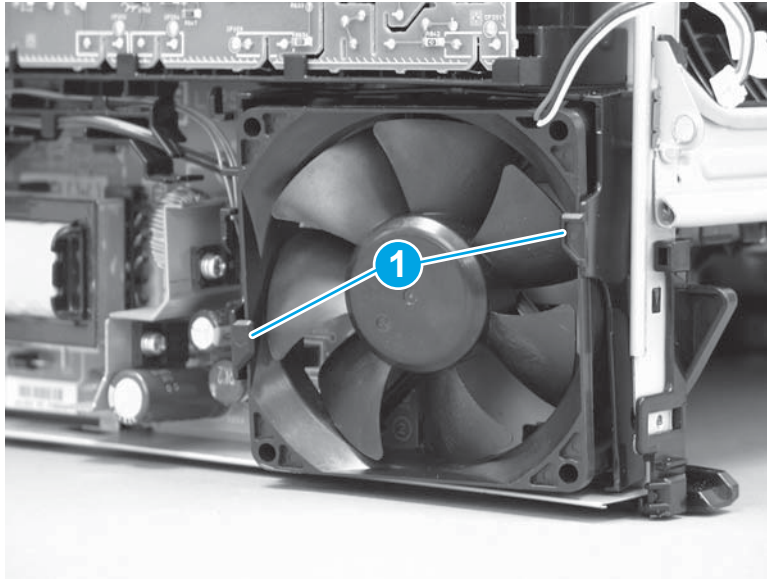

3. Remove the fan.

Figure 1-899 Remove the fan

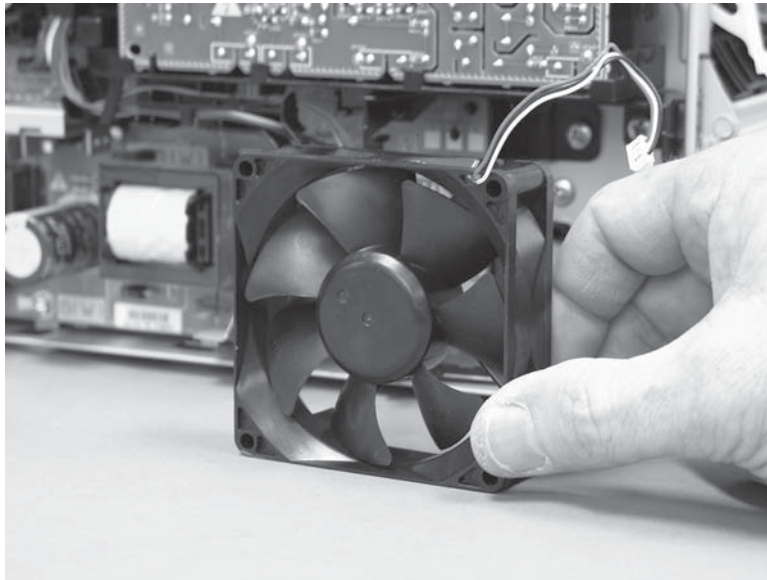

Step 5: Unpack the replacement assembly

Unpack the replacement part from the packaging.

<http://www8.hp.com/us/en/hp-information/environment/product-recycling.html>

 **NOTE:** HP recommends responsible disposal of the defective part.

Figure 1-900 Recycle and unpack

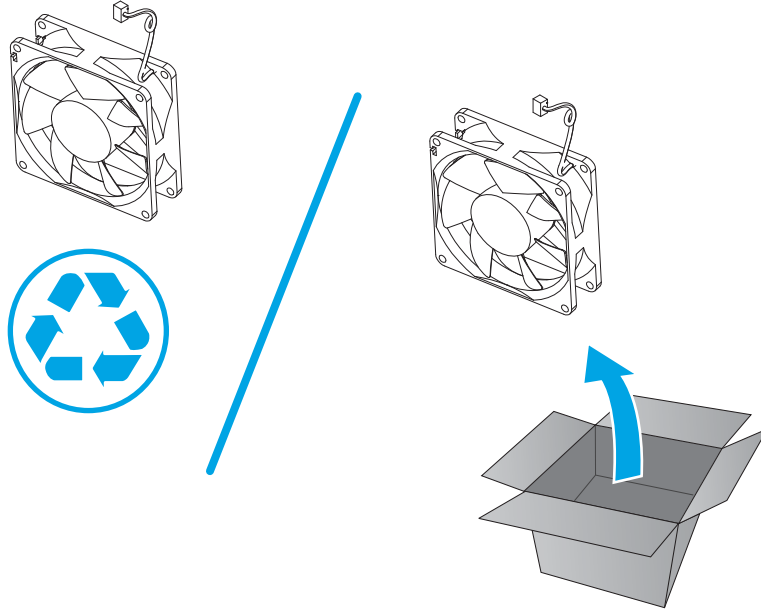

Step 6: Install the fan (FM1)

1. Position the fan in the holder. Make sure that the two tabs (callout 1) snap into place on the fan.

⚠ CAUTION: The fan must be correctly installed so that air is drawn into the printer. Make sure that the two arrows embossed on the right-side of the fan body—which indicate air flow direction—face upward and into the printer.

Figure 1-901 Install the fan

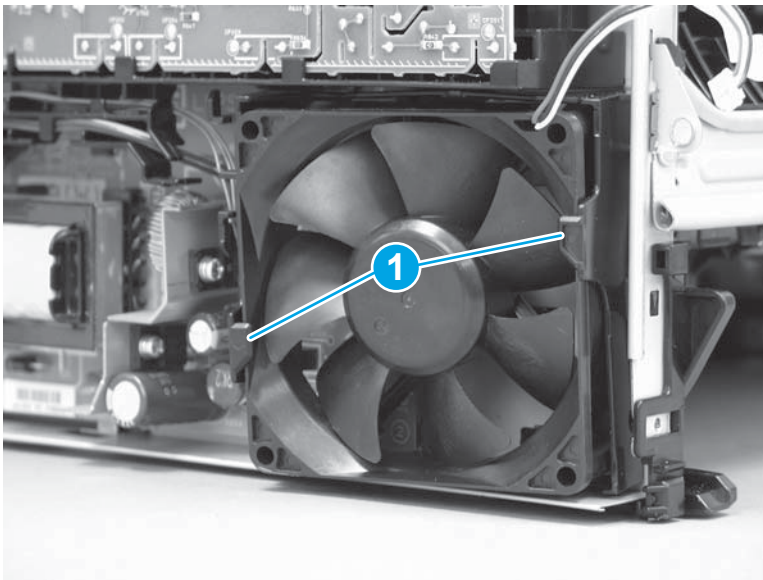

2. Install the wire harness on the retainer (callout 2), and then connect one connector (callout 2).

Figure 1-902 Connect one connector

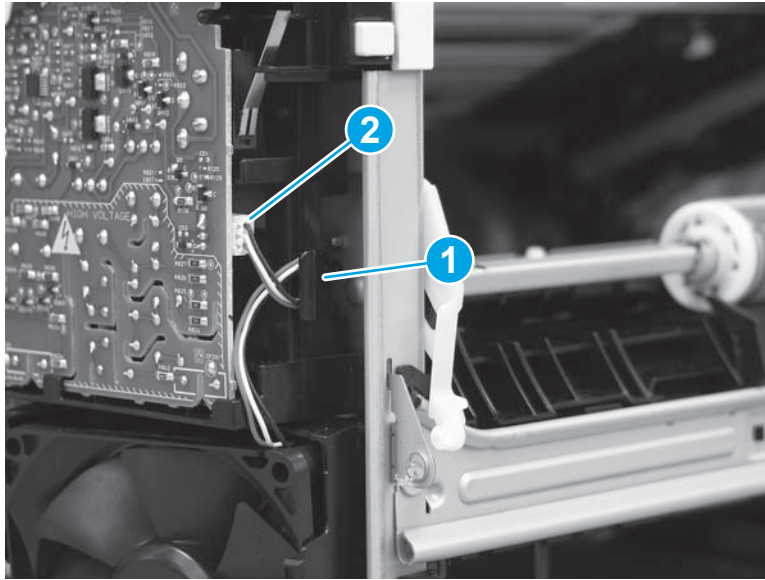

Step 7: Install the left cover

1. At the front of the printer, do one of the following:
 - **M403/M402:** Position the cover on the printer (callout 1), and then engage two bosses (callout 2).
 - **M427/M426:** Position the cover on the printer (callout 3), engage one tab (callout 4), and then engage two bosses (callout 4).

Figure 1-903 Install the cover

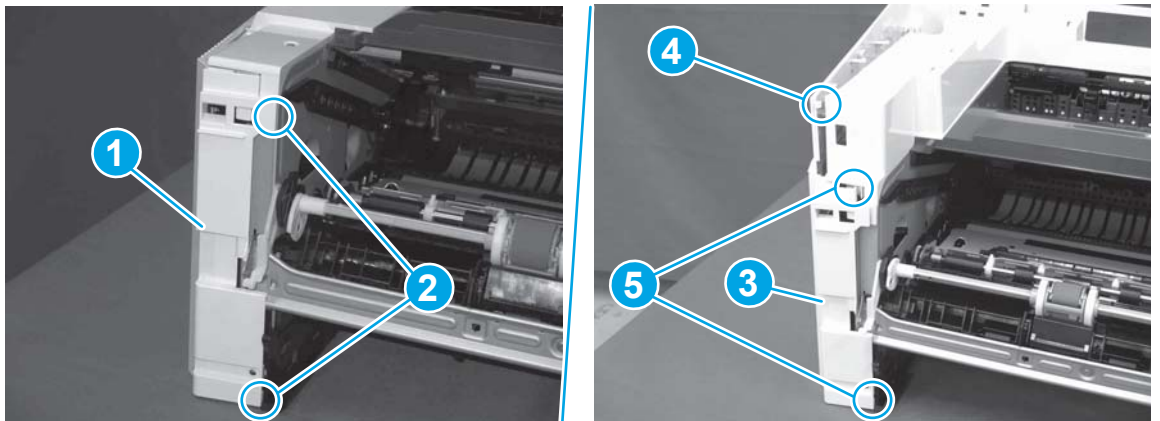

- Carefully rotate the rear of the cover onto the printer (callout 1), engage three tabs (callout 2), and then engage two bosses (callout 3).

Figure 1-904 Engage three tabs and two bosses

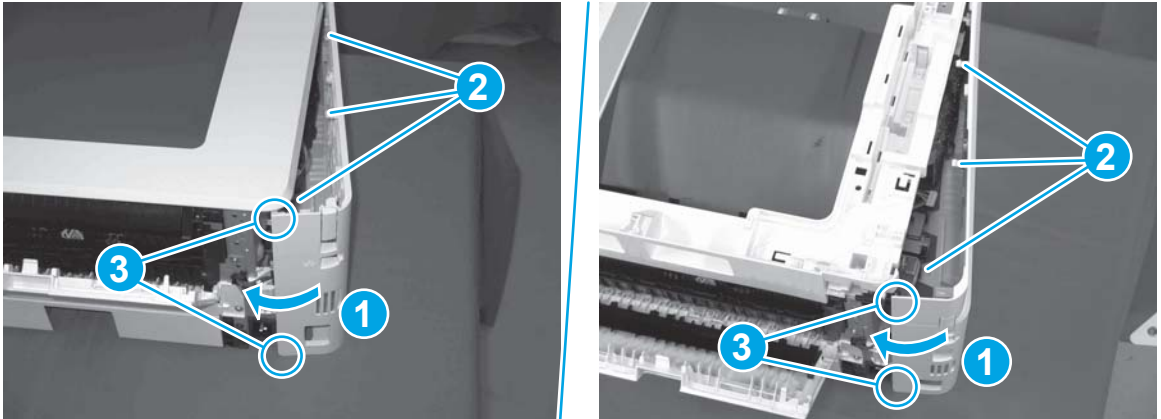

- Install one screw (callout 1).

Figure 1-905 Install one screw

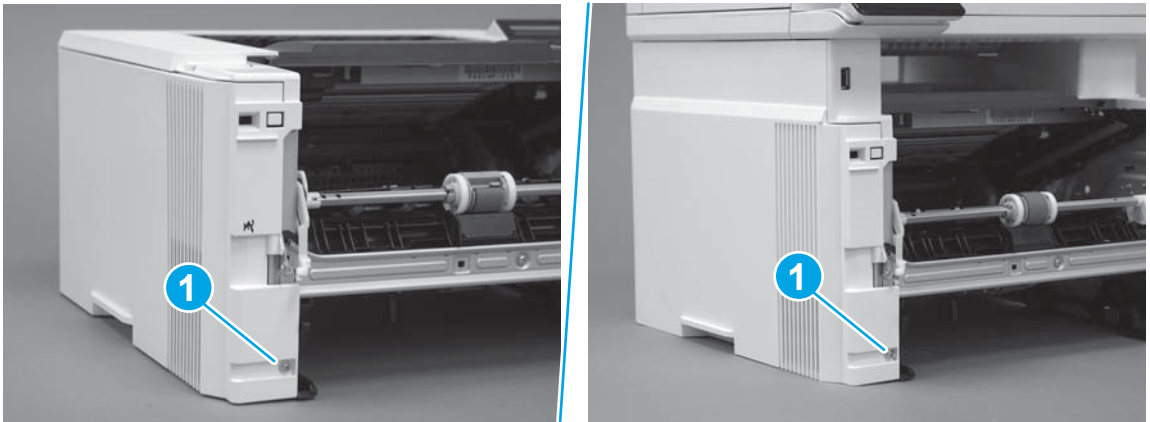

Step 8: Install the cartridge door assembly

 **Reinstallation tip:** After a replacement door is installed, make sure to install the nameplate (supplied in the kit) corresponding to the printer name on the door.

- Position the door close to the printer, and then engage the keyed pin on the left-side retainer arm with the hole in the door.

Figure 1-906 Engage the left-side retainer arm

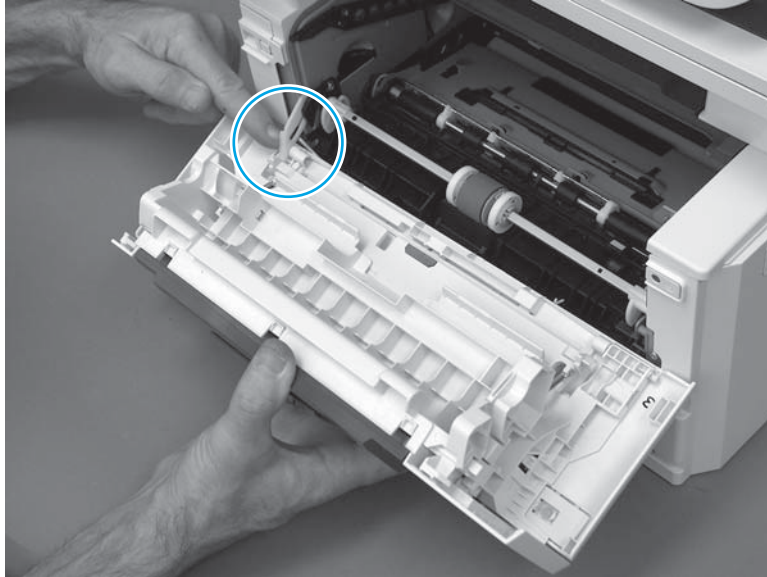

2. Engage the right-side door hinge pin with the hole in the chassis (callout 1).

Figure 1-907 Install the door

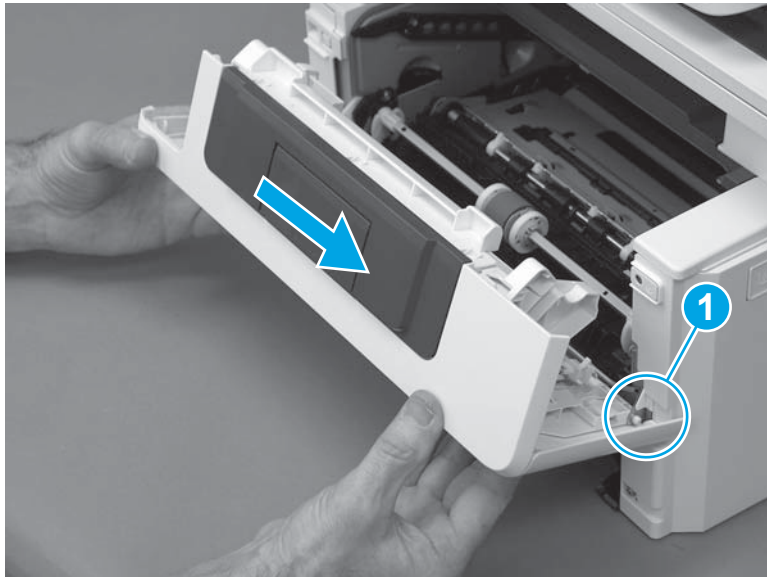

3. Install the link (callout 1).

 **IMPORTANT:** Make sure that the link snaps into place on the arm (callout 2). The link actuates the fuser pressure-release mechanism.

Figure 1-908 Install the pressure-release link

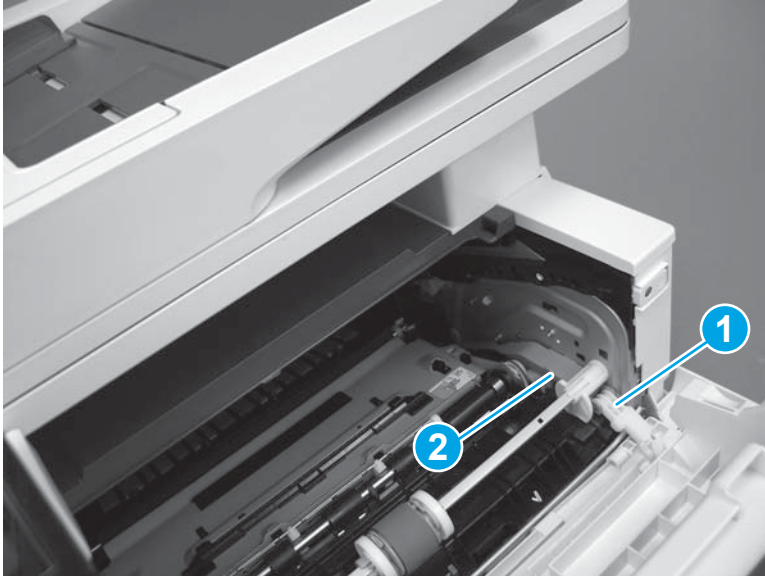

4. Slide the guide into the printer (callout 1), and then make sure that the tab (callout 2) snaps into place to secure the guide to the chassis.

Figure 1-909 Install the guide

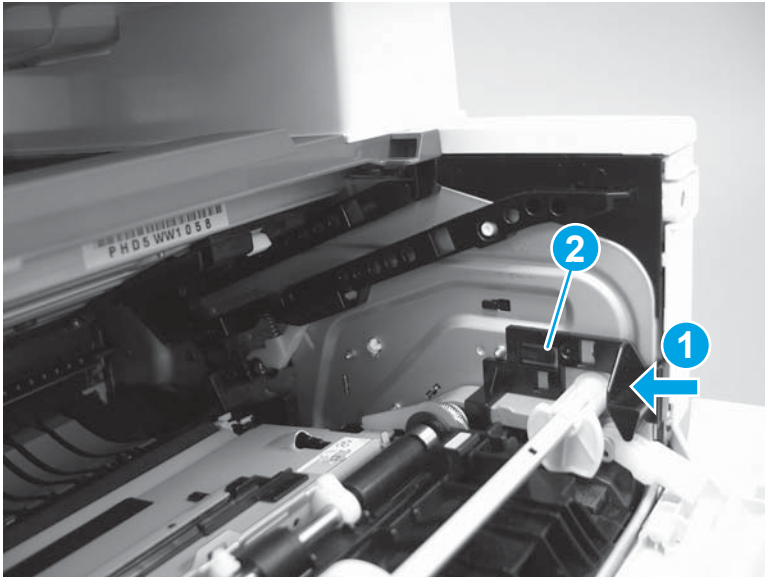

5. Position the shaft on the door, and then align the left-side hinge on the door with the hole in the chassis (callout 1).

Figure 1-910 Align the hinge

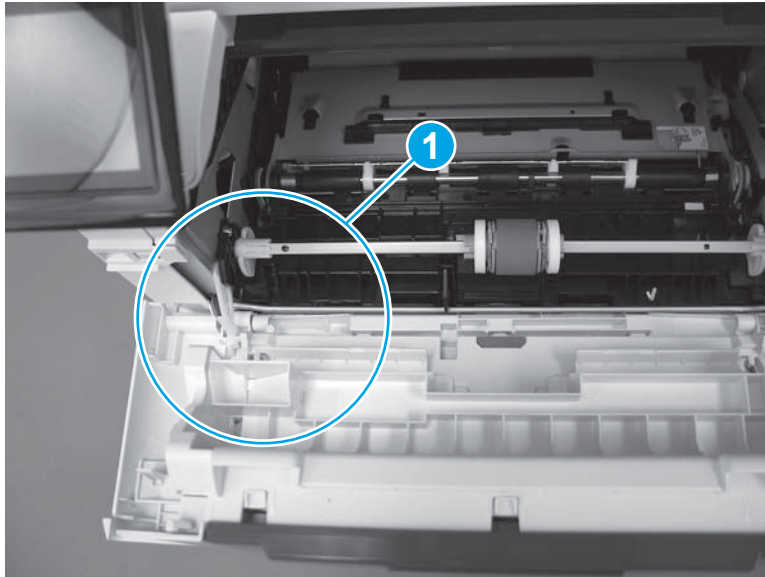

6. Push the shaft towards the left side of the printer to install it (callout 1).

 **Reinstallation tip:** Make sure that the support shaft is fully installed and correctly orientated (callout 2) so that it will not interfere with the door opening and closing.

Figure 1-911 Install the support shaft



Step 9: Install Tray 2

- ▲ Slide the tray straight into the printer to install it.

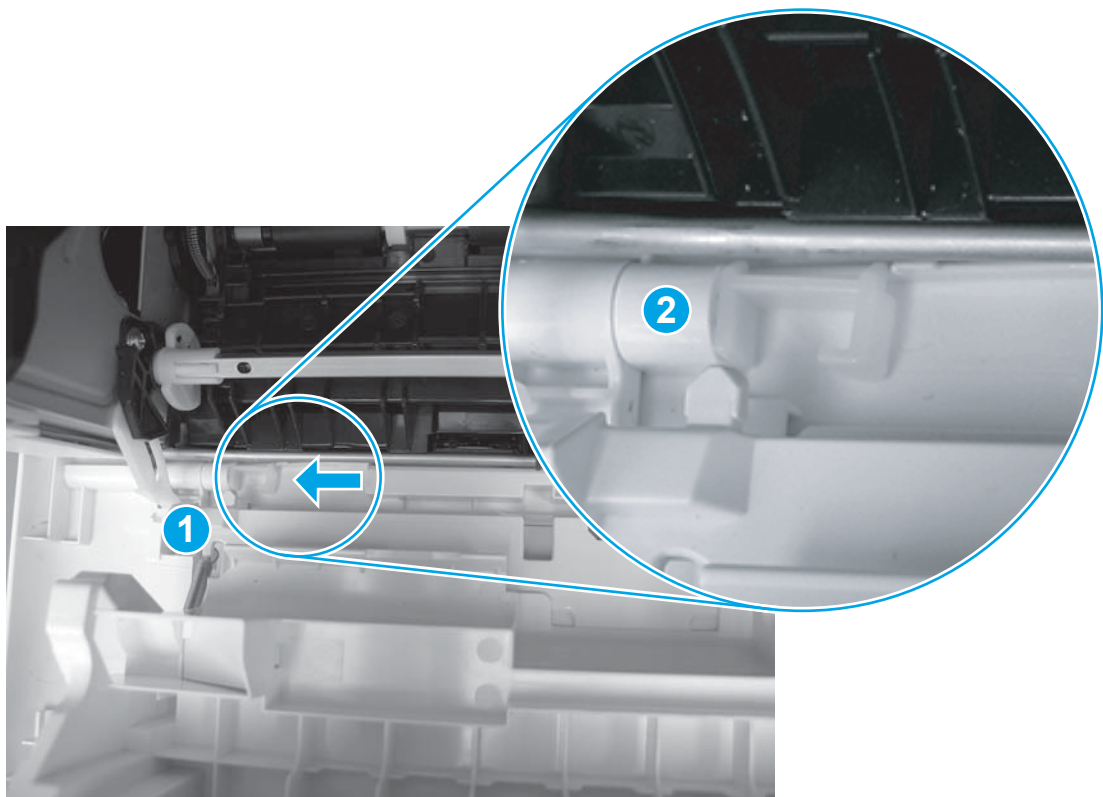
Figure 1-912 Install the tray



Removal and replacement: Fan holder (FM1)

- [Introduction](#)
- [Step 1: Remove Tray 2](#)
- [Step 2: Remove the cartridge door assembly](#)
- [Step 3: Remove the left cover](#)
- [Step 4: Remove the fan \(FM1\)](#)
- [Step 5: Remove the fan holder \(FM1\)](#)
- [Step 6: Unpack the replacement assembly](#)
- [Step 7: Install the fan holder \(FM1\)](#)
- [Step 8: Install the fan \(FM1\)](#)
- [Step 9: Install the left cover](#)
- [Step 10: Install the cartridge door assembly](#)
- [Step 11: Install Tray 2](#)

Introduction

This document provides the procedures to remove and replace the fan holder (FM1).

Before performing service

Turn the printer power off

- Disconnect the power cable.

 **WARNING!** To avoid damage to the printer, turn the printer off, wait 30 seconds, and then remove the power cable before attempting to service the printer.

Use the table below to identify the correct part number for your printer. To order the part, go to www.hp.com/buy/parts.

Fan holder (FM1) part number	
RC4-2891-000CN	Fan holder (FM1)

Required tools

- #2 Phillips screwdriver with a magnetic tip.

After performing service

Turn the printer power on

- Connect the power cable.
- Use the power switch to turn the power on.

Post service test

Listen for the fan to rotate when the printer power is turned on.

Step 1: Remove Tray 2

- ▲ Pull the tray straight out of the printer to remove it.

Figure 1-913 Remove the tray



Step 2: Remove the cartridge door assembly



NOTE: If the toner cartridge was not removed prior to servicing the printer, remove it now.

1. Release one tab (callout 1), and then slide shaft (callout 2) in the direction the arrow indicates and remove it.



TIP: It might be easier to release the support shaft by using a small flat-blade screwdriver.

Figure 1-914 Release the support shaft

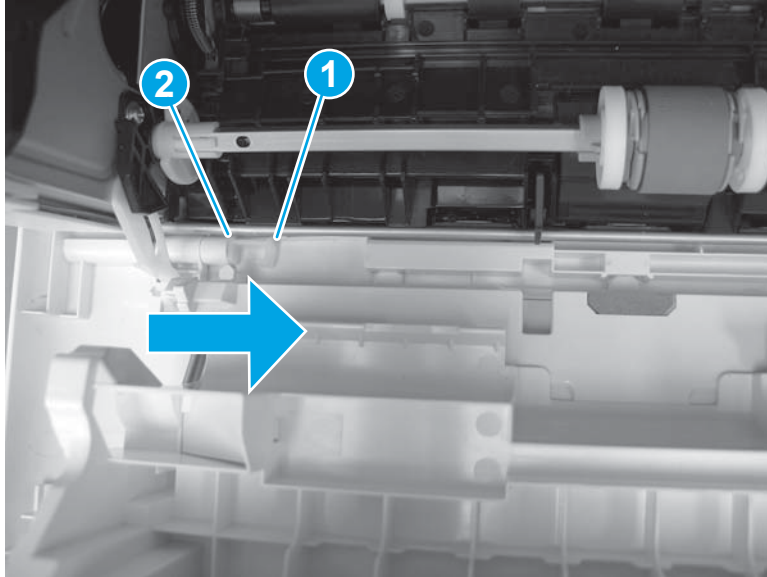

2. Release one tab (callout 1), and then slide the guide (callout 2) in the direction the arrow indicates and remove it.

Figure 1-915 Remove the guide

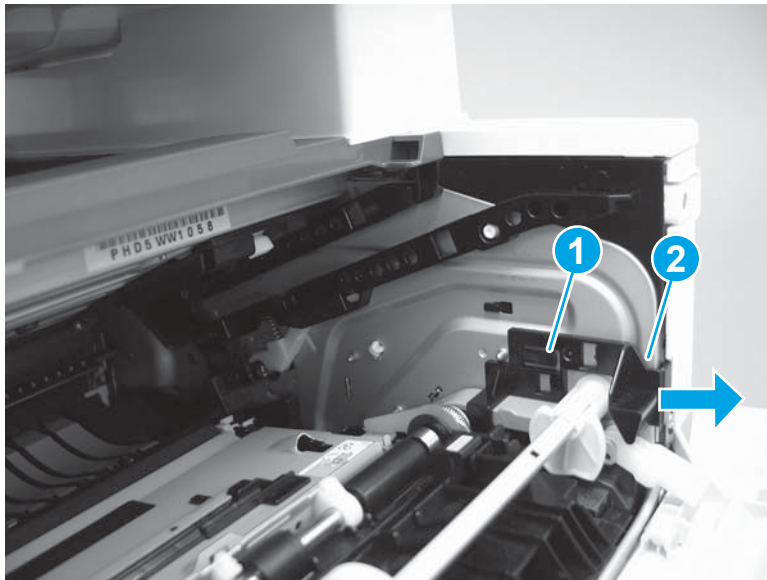

3. Remove the link arm (callout 1).

Figure 1-916 Remove the link arm

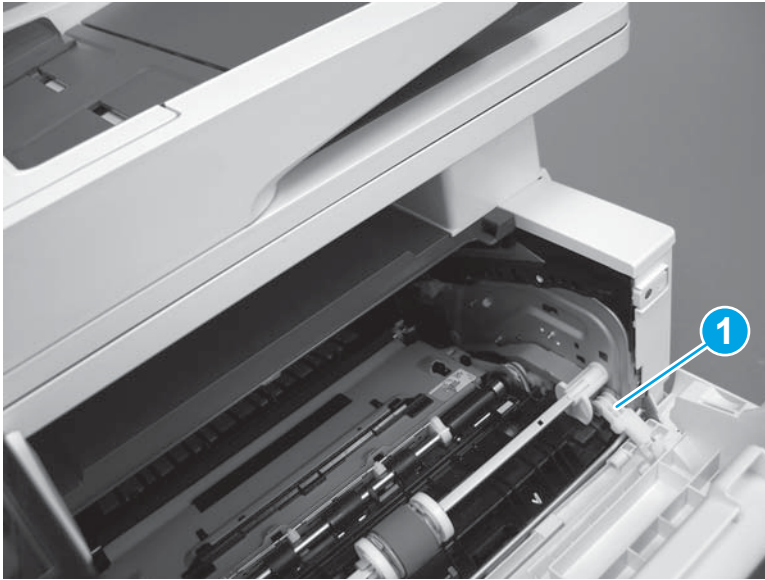

4. Slide the cartridge door assembly (callout 1) in the direction the arrow indicates and remove it.

Figure 1-917 Remove the door

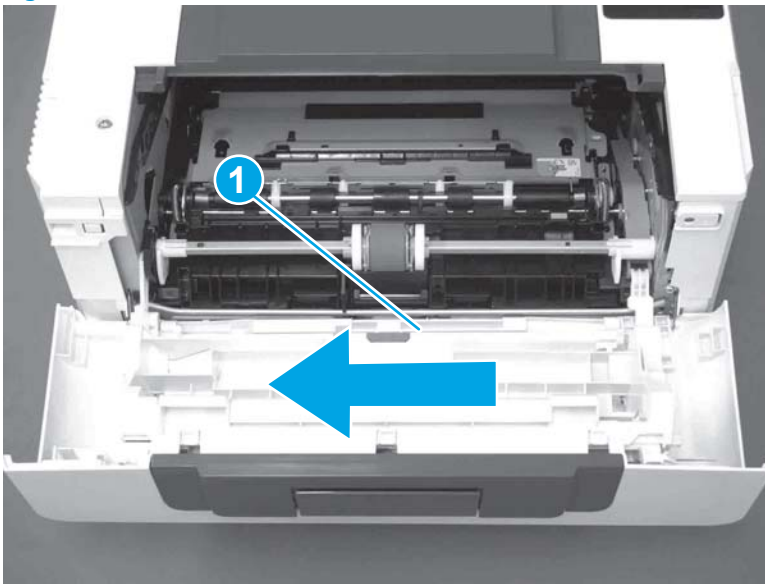

5. Remove the link (callout 1) from the cartridge door assembly (callout 2).

Figure 1-918 Release the left-side retainer arm

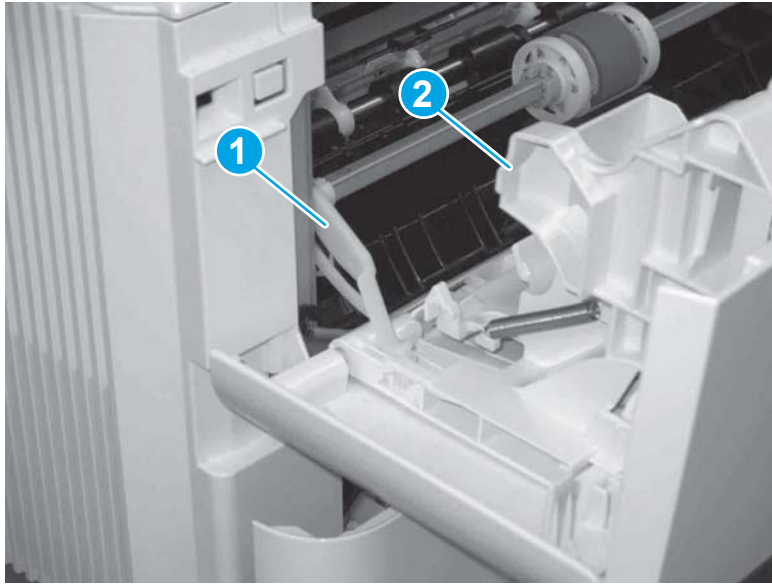

Step 3: Remove the left cover

1. Remove one screw (callout 1).

Figure 1-919 Remove one screw

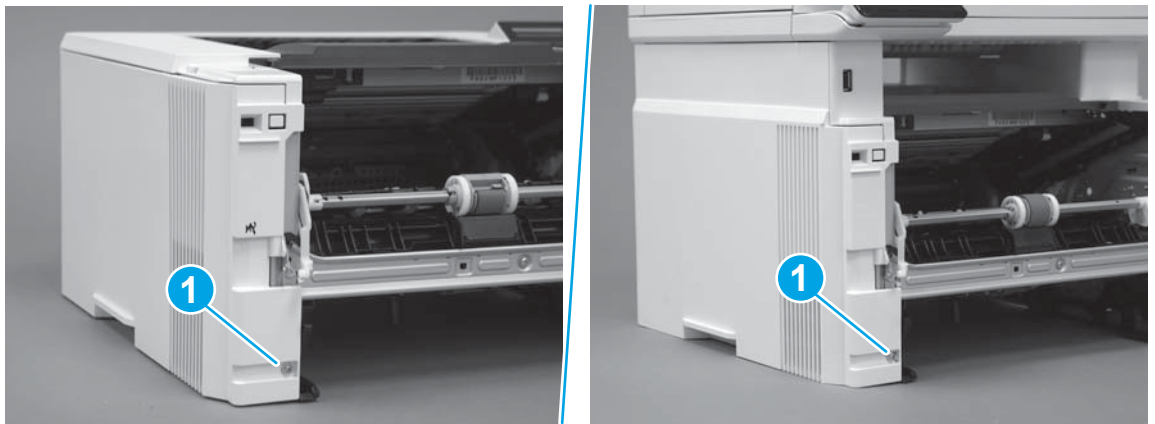

2. Open the rear door, release two bosses (callout 1), and then release three tabs (callout 2).

Figure 1-920 Release two bosses and three tabs

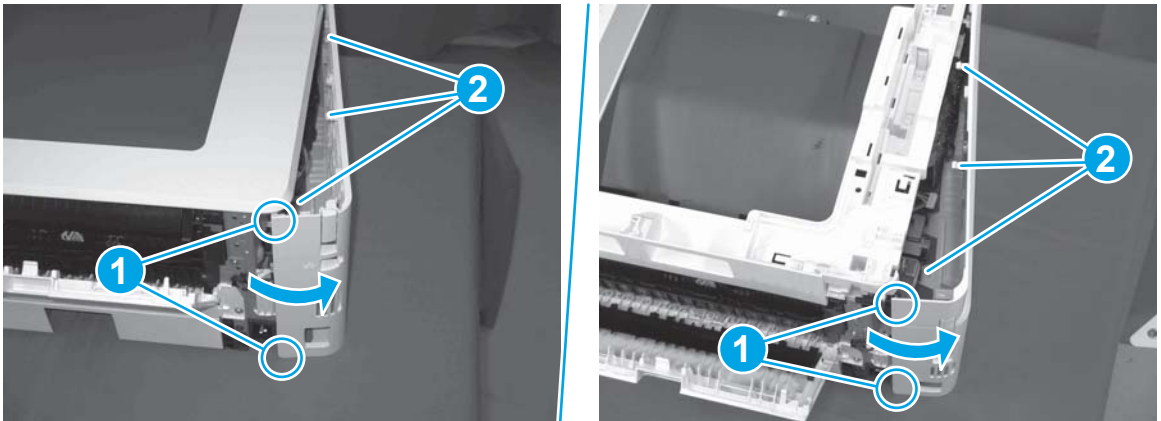

3. At the front of the printer, do one of the following:
 - **M403/M402:** Release two bosses (callout 1), and then remove the cover (callout 2).
 - **M427/M426:** Release one tab (callout 3), two bosses (callout 4), and then remove the cover (callout 5).

CAUTION: Be careful when releasing the upper bosses on the M427/M426 cover. One portion of the cover (callout 6) is fragile and is easily broken.

Figure 1-921 Remove the cover

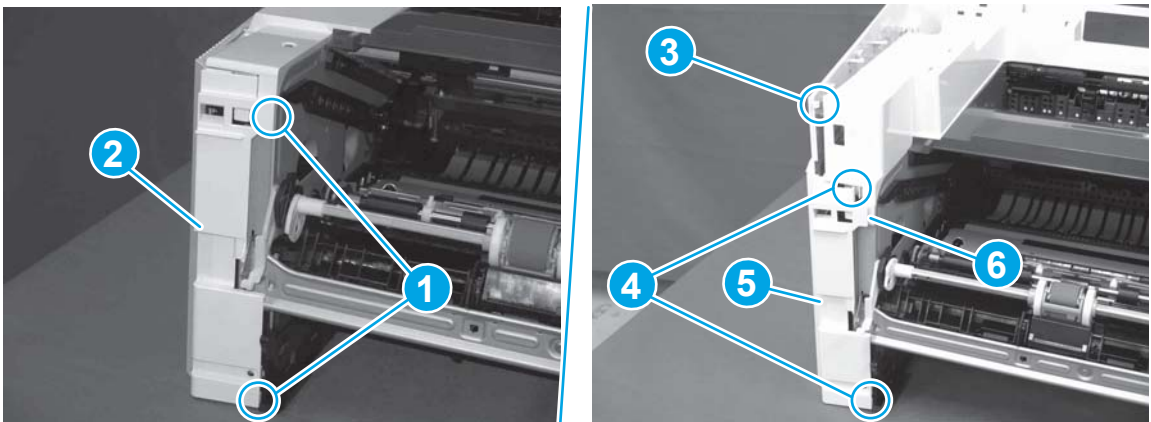

Step 4: Remove the fan (FM1)

1. Disconnect one connector (callout 1), and then release the wire harness from the retainer (callout 2).

Figure 1-922 Disconnect one connector

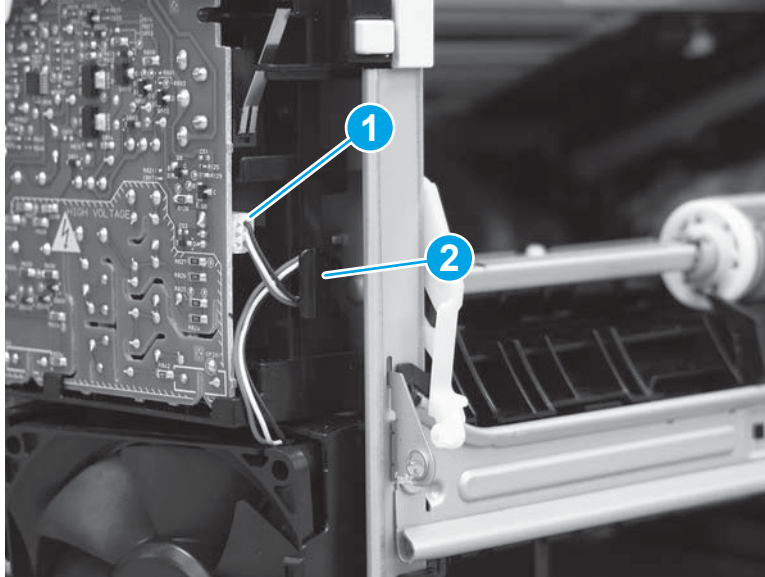

2. Release two tabs (callout 1).

Figure 1-923 Release two tabs

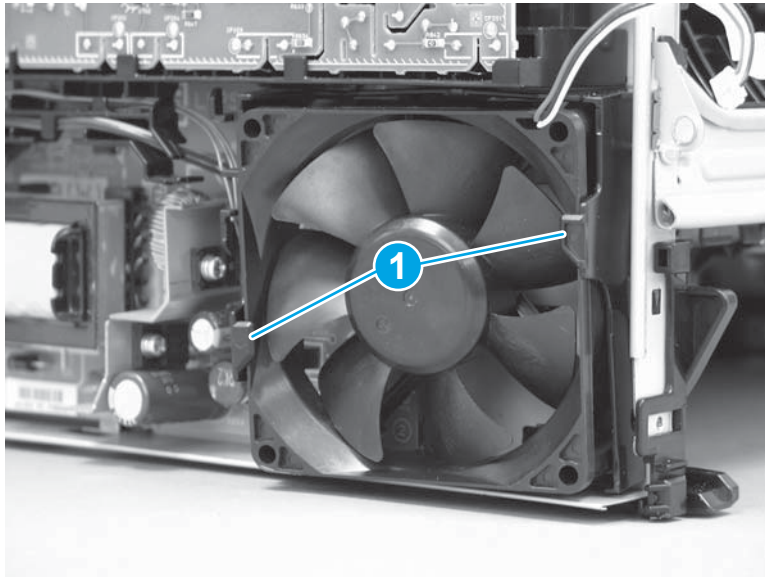

3. Remove the fan.

Figure 1-924 Remove the fan

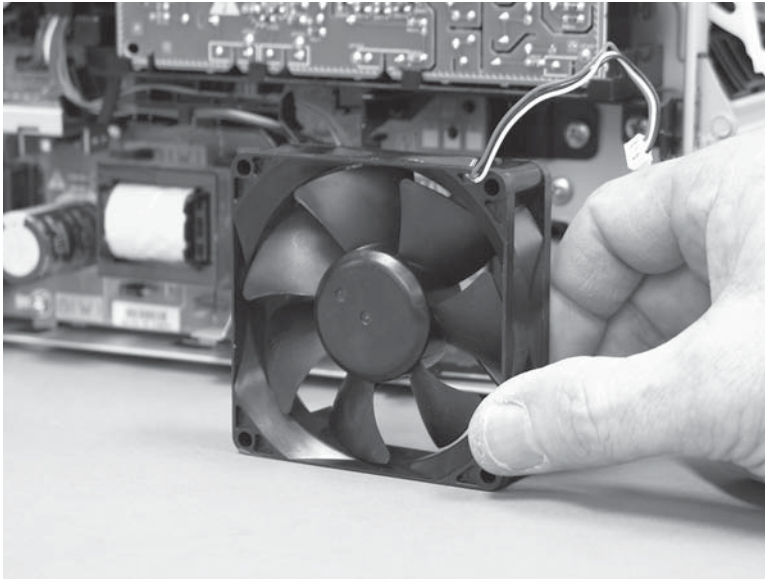

Step 5: Remove the fan holder (FM1)

1. Remove one screw (callout 1).

Figure 1-925 Remove one screw

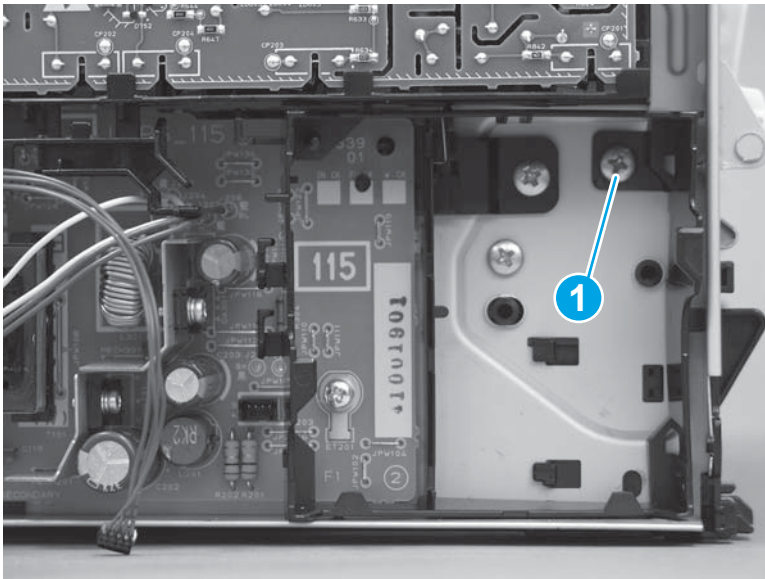

2. Release one tab at the top-left side of the fan holder (callout 1), and then rotate the top-left side corner of the holder away from the printer.

 **Reinstallation tip:** Use a flat-blade screwdriver to slightly flex the top of the holder down to make it easier to disengage this tab.

Figure 1-926 Release one tab



3. Slightly flex the right side of the holder to release one tab (callout 1), and then rotate the top of the holder away from the printer (callout 2).

Figure 1-927 Release one tab

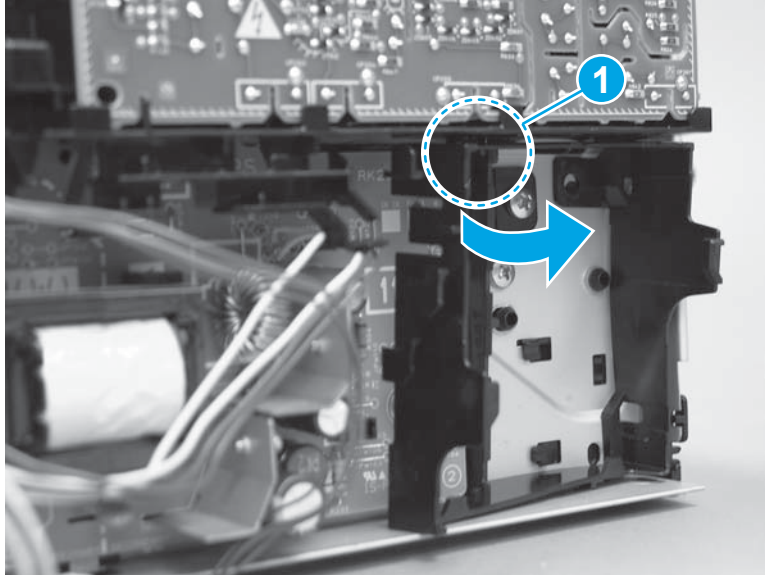
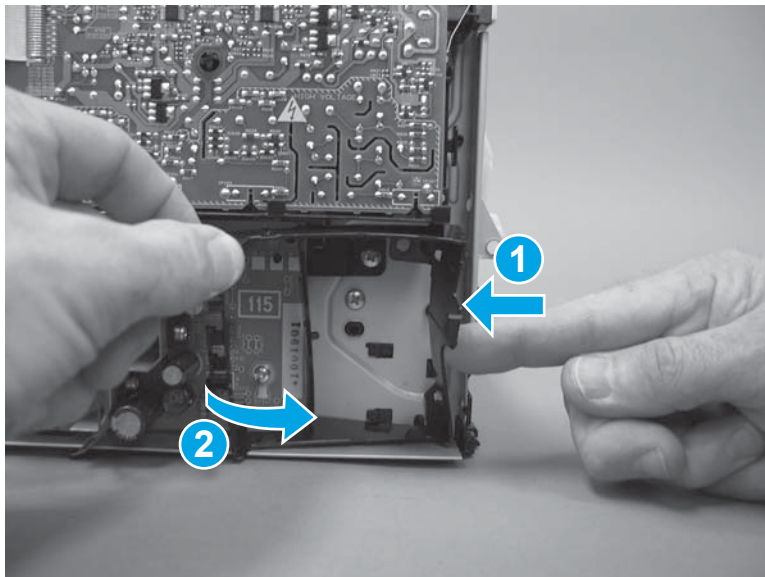

4. Lift the holder up to release two alignment tabs on the bottom of the holder, and then remove the holder.

Figure 1-928 Remove the holder

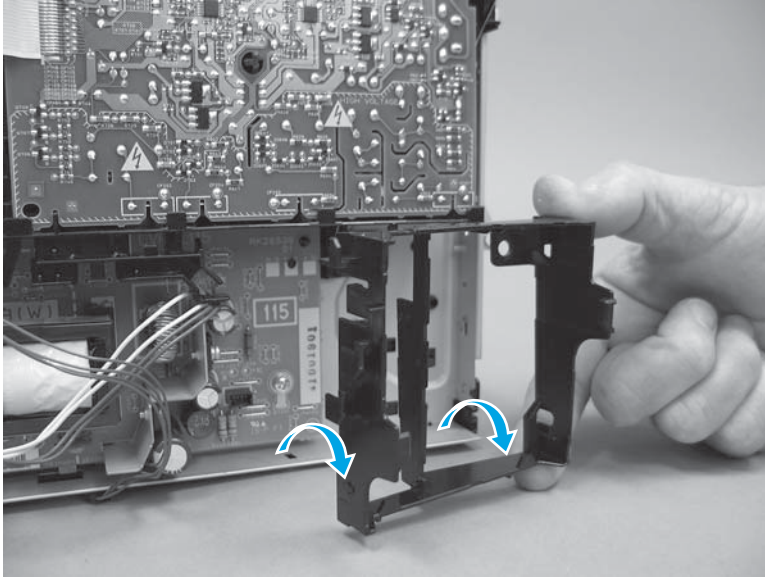

Step 6: Unpack the replacement assembly

Unpack the replacement part from the packaging.

<http://www8.hp.com/us/en/hp-information/environment/product-recycling.html>



NOTE: HP recommends responsible disposal of the defective part.

Figure 1-929 Recycle and unpack

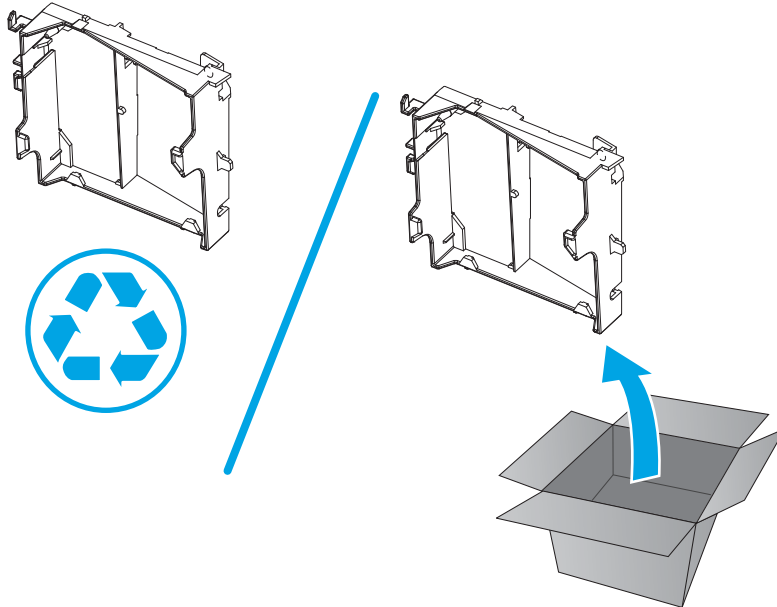

Step 7: Install the fan holder (FM1)

1. Position the bottom edge of the holder on the chassis—engage the two alignment tabs on the bottom of the holder with the slots in the chassis.

Figure 1-930 Install the holder

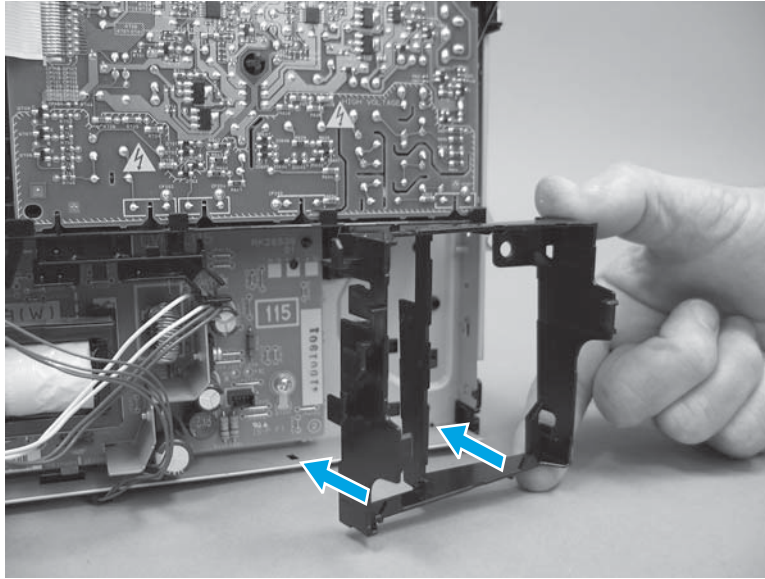

2. Rotate the top of the holder toward the printer (callout 1), and then engage one tab on the right side of the holder (callout 2).

Figure 1-931 Engage one tab

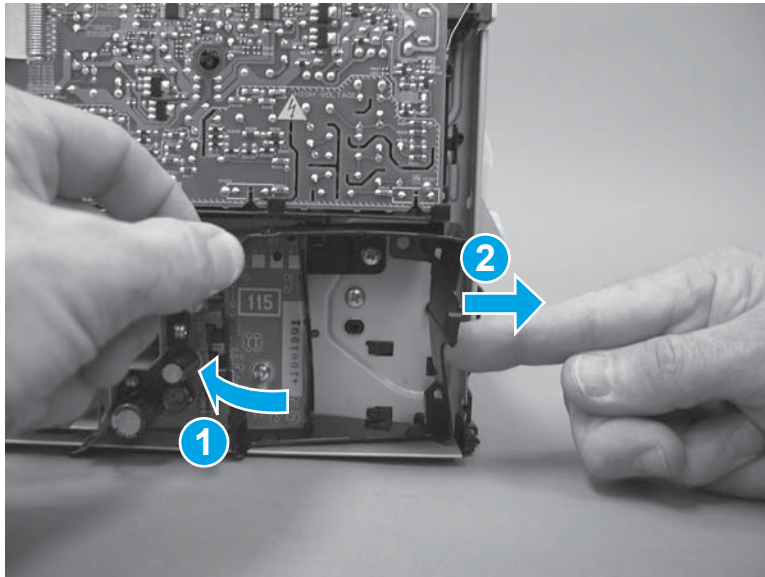

3. Rotate the top-left side corner of the holder toward the printer, and then engage one tab on the holder (callout 1).

 **Reinstallation tip:** Use a flat-blade screwdriver to slightly flex the top of the holder down to make it easier to engage this tab.

Figure 1-932 Engage one tab



4. Install one screw (callout 1).

Figure 1-933 Install one screw

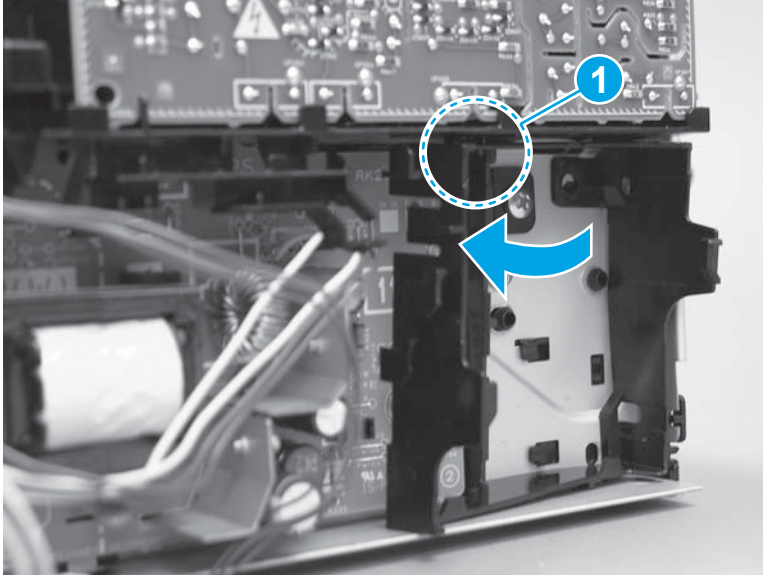
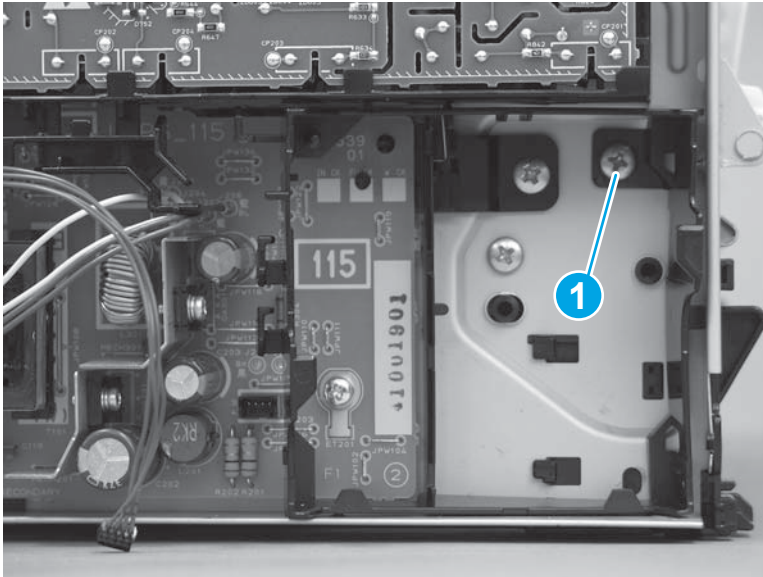

Step 8: Install the fan (FM1)

1. Position the fan in the holder. Make sure that the two tabs (callout 1) snap into place on the fan.

 **CAUTION:** The fan must be correctly installed so that air is drawn into the printer. Make sure that the two arrows embossed on the right-side of the fan body—which indicate air flow direction—face upward and into the printer.

Figure 1-934 Install the fan



2. Install the wire harness on the retainer (callout 2), and then connect one connector (callout 2).

Figure 1-935 Connect one connector

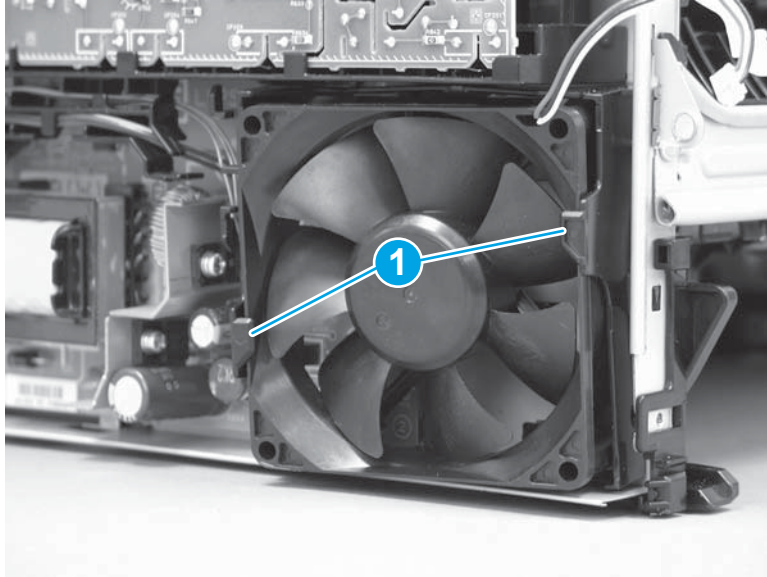
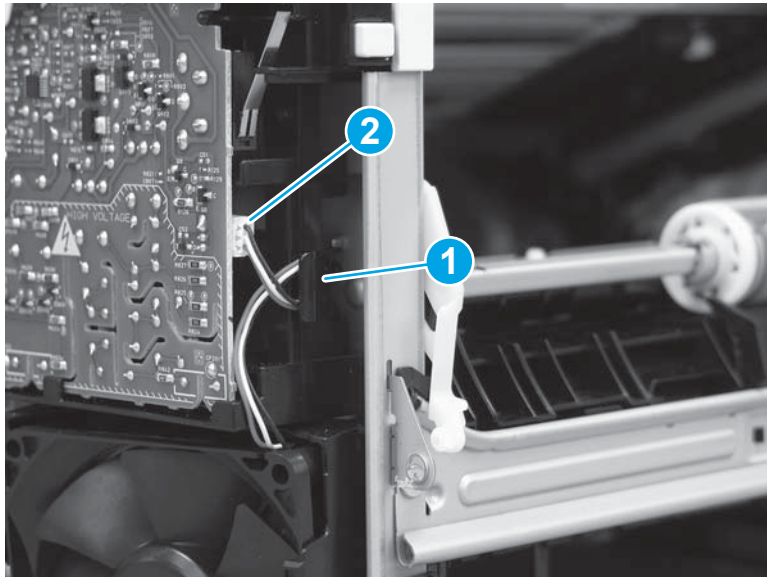

Step 9: Install the left cover

1. At the front of the printer, do one of the following:
 - **M403/M402:** Position the cover on the printer (callout 1), and then engage two bosses (callout 2).
 - **M427/M426:** Position the cover on the printer (callout 3), engage one tab (callout 4), and then engage two bosses (callout 4).

Figure 1-936 Install the cover

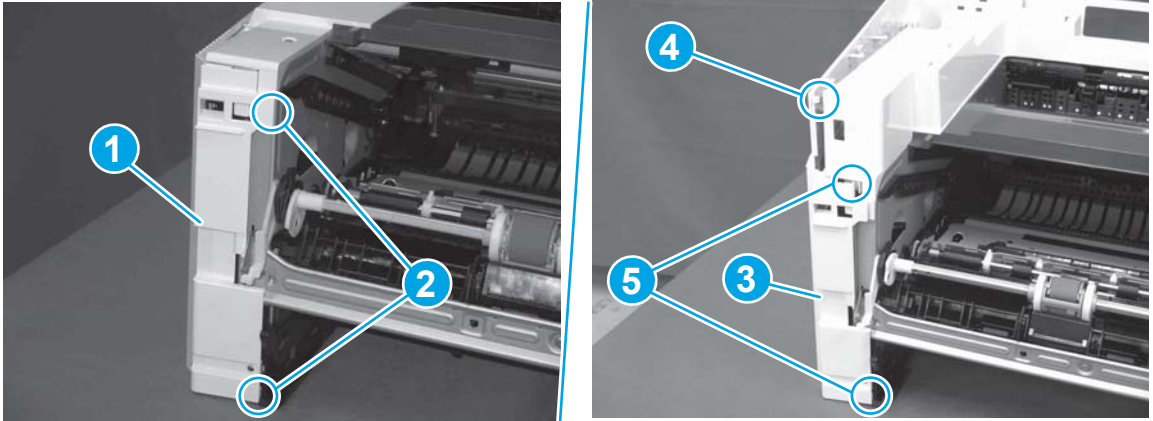

2. Carefully rotate the rear of the cover onto the printer (callout 1), engage three tabs (callout 2), and then engage two bosses (callout 3).

Figure 1-937 Engage three tabs and two bosses

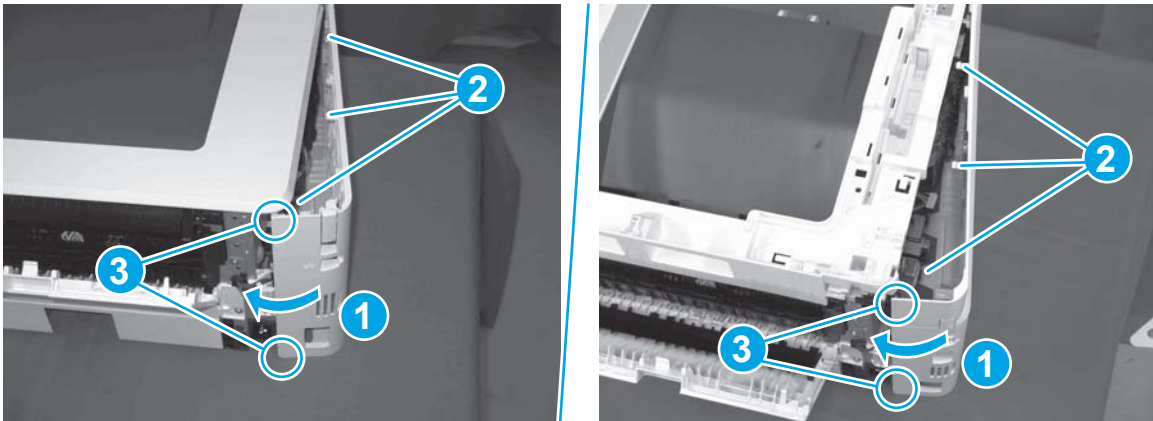

3. Install one screw (callout 1).

Figure 1-938 Install one screw

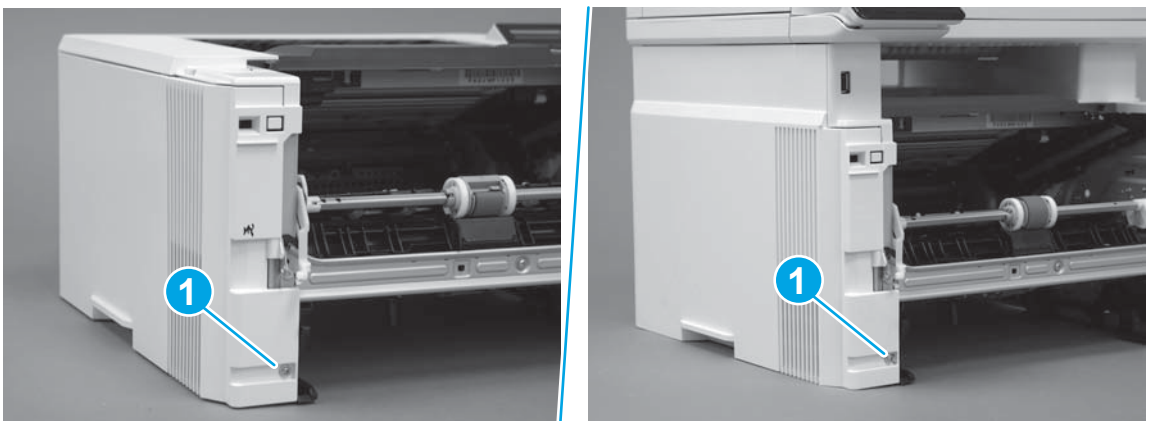

Step 10: Install the cartridge door assembly

 **Reinstallation tip:** After a replacement door is installed, make sure to install the nameplate (supplied in the kit) corresponding to the printer name on the door.

1. Position the door close to the printer, and then engage the keyed pin on the left-side retainer arm with the hole in the door.

Figure 1-939 Engage the left-side retainer arm

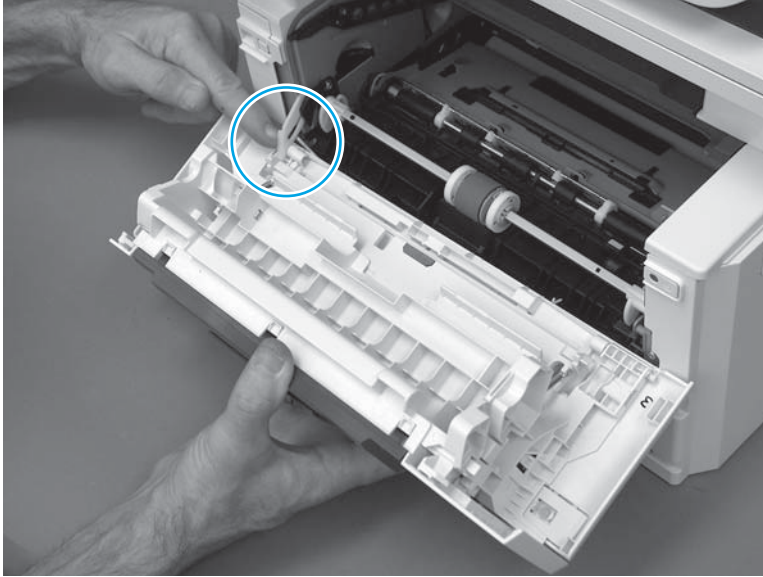

2. Engage the right-side door hinge pin with the hole in the chassis (callout 1).

Figure 1-940 Install the door

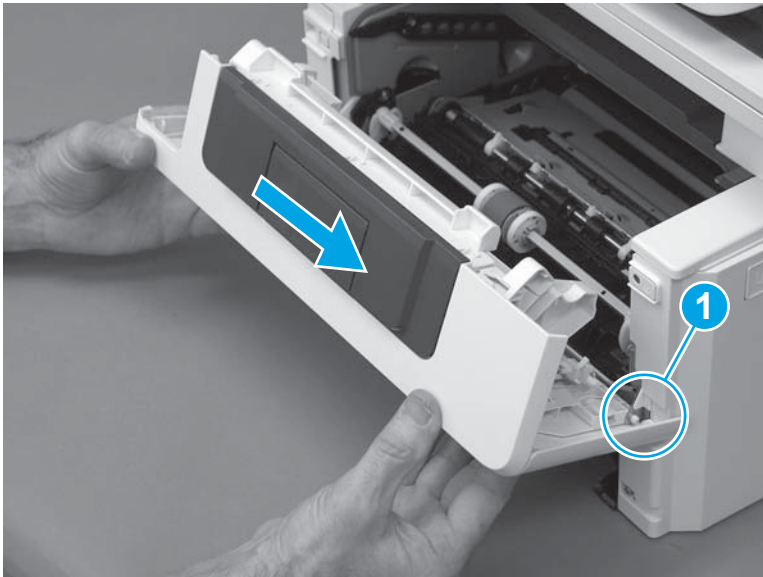

3. Install the link (callout 1).

 **IMPORTANT:** Make sure that the link snaps into place on the arm (callout 2). The link actuates the fuser pressure-release mechanism.

Figure 1-941 Install the pressure-release link

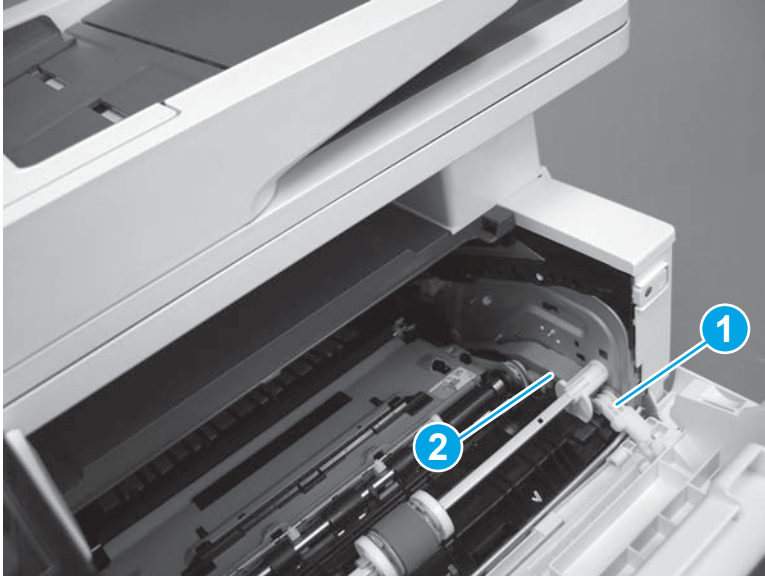

4. Slide the guide into the printer (callout 1), and then make sure that the tab (callout 2) snaps into place to secure the guide to the chassis.

Figure 1-942 Install the guide

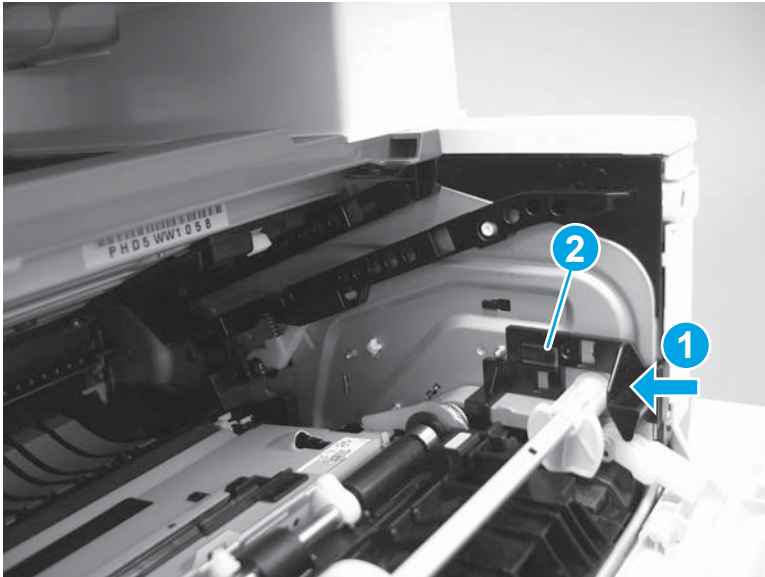

5. Position the shaft on the door, and then align the left-side hinge on the door with the hole in the chassis (callout 1).

Figure 1-943 Align the hinge

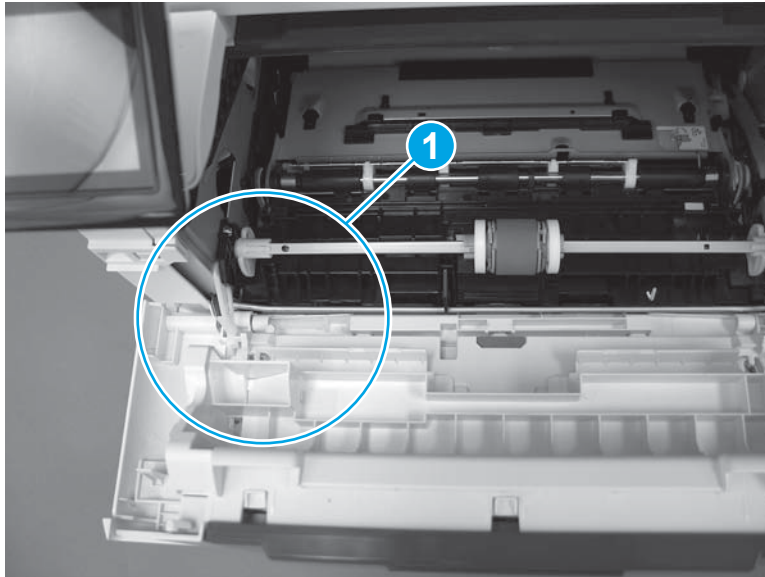

6. Push the shaft towards the left side of the printer to install it (callout 1).

 **Reinstallation tip:** Make sure that the support shaft is fully installed and correctly orientated (callout 2) so that it will not interfere with the door opening and closing.

Figure 1-944 Install the support shaft



Step 11: Install Tray 2

- ▲ Slide the tray straight into the printer to install it.

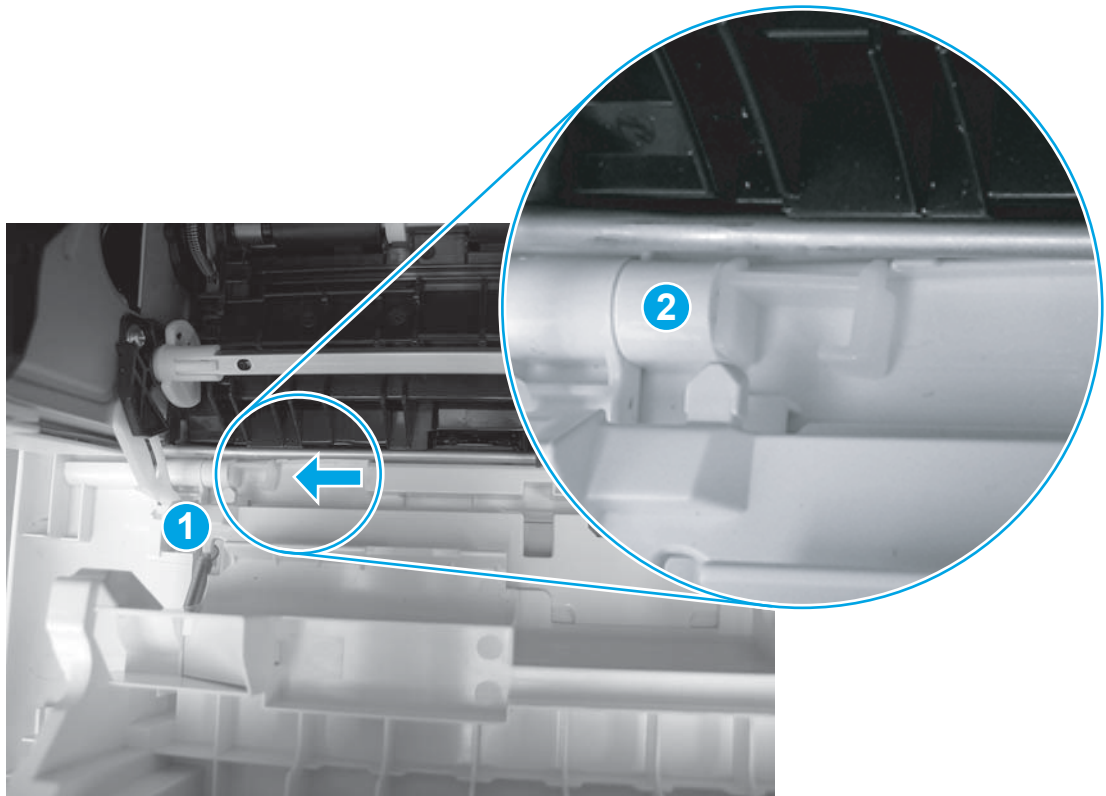
Figure 1-945 Install the tray



Removal and replacement: Laser scanner assembly

- [Introduction](#)
- [Step 1: Remove Tray 2](#)
- [Step 2: Remove the cartridge door assembly](#)
- [Step 3: Remove the left cover](#)
- [Step 4: Remove the right cover](#)
- [Step 5: Remove the integrated scanner assembly \(M427/M246\)](#)
- [Step 6: Remove the control panel \(M427/M246\)](#)
- [Step 7: Remove the top cover \(M427/M426\)](#)
- [Step 8: Remove the top cover \(M403/M402\)](#)
- [Step 9: Remove the paper delivery tray \(output bin\)](#)
- [Step 10: Remove the laser scanner assembly](#)
- [Step 11: Unpack the replacement assembly](#)
- [Step 12: Install the laser scanner assembly](#)
- [Step 13: Install the paper delivery tray \(output bin\)](#)
- [Step 14: Install the top cover \(M403/M402\)](#)
- [Step 15: Install the top cover \(M427/M426\)](#)
- [Step 16: Install the control panel \(M427/M246\)](#)
- [Step 17: Install the integrated scanner assembly \(M427/M246\)](#)
- [Step 18: Install the right cover](#)
- [Step 19: Install the left cover](#)
- [Step 20: Install the cartridge door assembly](#)
- [Step 21: Install Tray 2](#)

Introduction

This document provides the procedures to remove and replace the laser scanner assembly.

Before performing service

Turn the printer power off

- Disconnect the power cable.

 **WARNING!** To avoid damage to the printer, turn the printer off, wait 30 seconds, and then remove the power cable before attempting to service the printer.

Use the table below to identify the correct part number for your printer. To order the part, go to www.hp.com/buy/parts.

Laser scanner assembly part number

RM2-5528-000CN

Laser scanner assembly

Required tools

- #2 Phillips screwdriver with a magnetic tip.

After performing service**Turn the printer power on**

- Connect the power cable.
- Use the power switch to turn the power on.

Post service test

Make sure that the printer initializes to a **Ready** state.

Print a configuration page to make sure that the printer is functioning correctly.

Step 1: Remove Tray 2

- ▲ Pull the tray straight out of the printer to remove it.

Figure 1-946 Remove the tray**Step 2: Remove the cartridge door assembly**

NOTE: If the toner cartridge was not removed prior to servicing the printer, remove it now.

1. Release one tab (callout 1), and then slide shaft (callout 2) in the direction the arrow indicates and remove it.



TIP: It might be easier to release the support shaft by using a small flat-blade screwdriver.

Figure 1-947 Release the support shaft

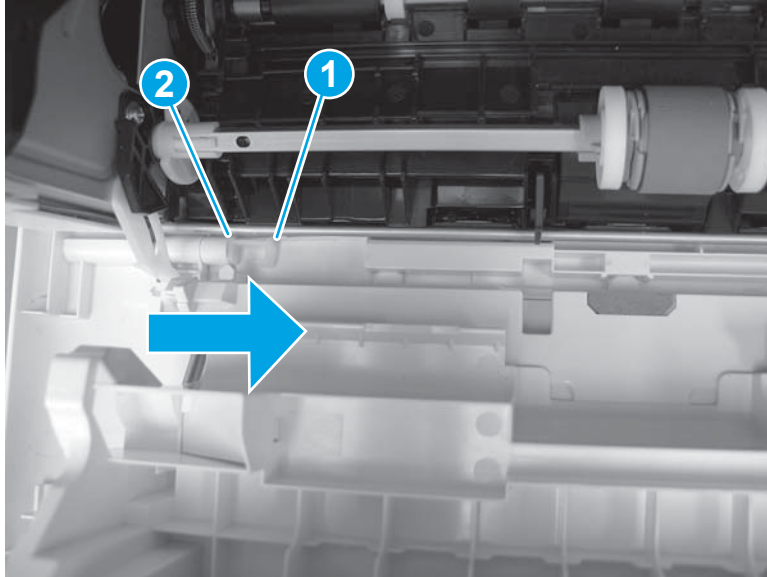

2. Release one tab (callout 1), and then slide the guide (callout 2) in the direction the arrow indicates and remove it.

Figure 1-948 Remove the guide

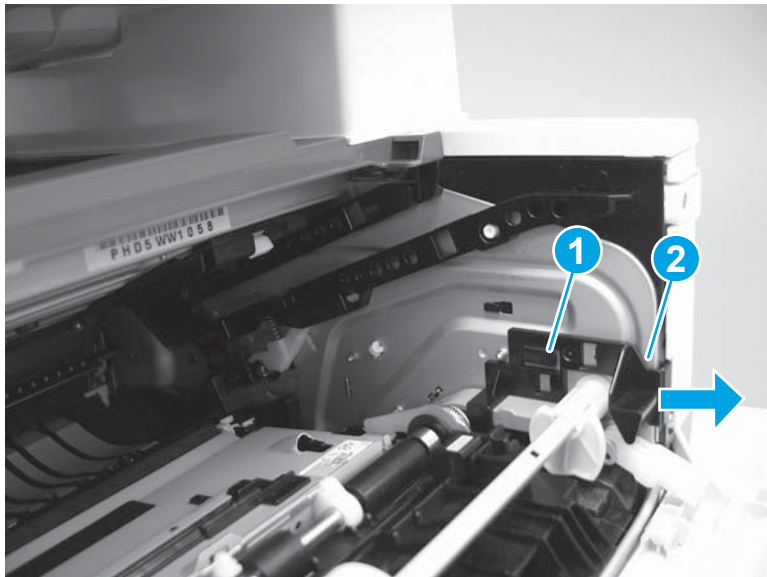

3. Remove the link arm (callout 1).

Figure 1-949 Remove the link arm

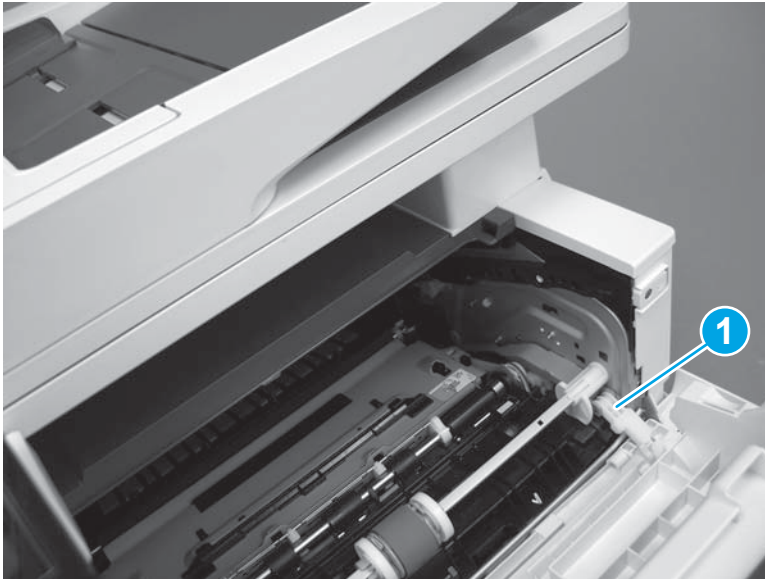

4. Slide the cartridge door assembly (callout 1) in the direction the arrow indicates and remove it.

Figure 1-950 Remove the door

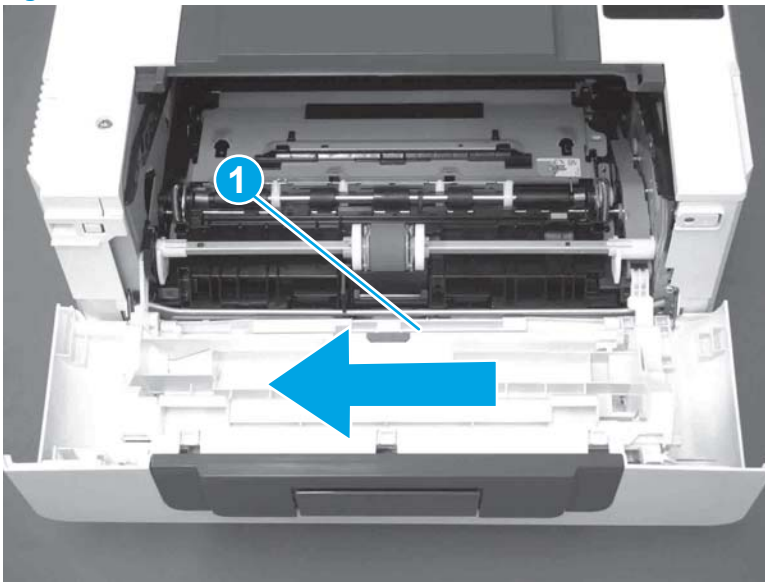

5. Remove the link (callout 1) from the cartridge door assembly (callout 2).

Figure 1-951 Release the left-side retainer arm

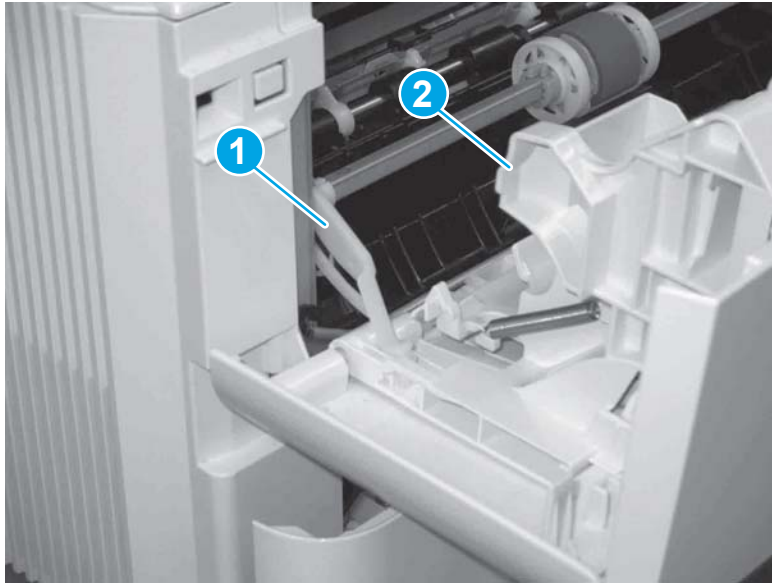

Step 3: Remove the left cover

1. Remove one screw (callout 1).

Figure 1-952 Remove one screw

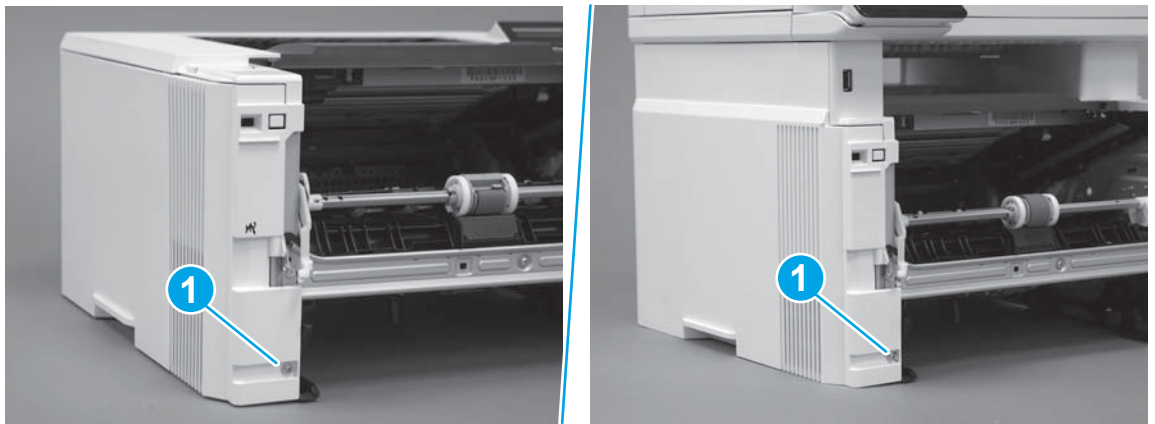

2. Open the rear door, release two bosses (callout 1), and then release three tabs (callout 2).

Figure 1-953 Release two bosses and three tabs

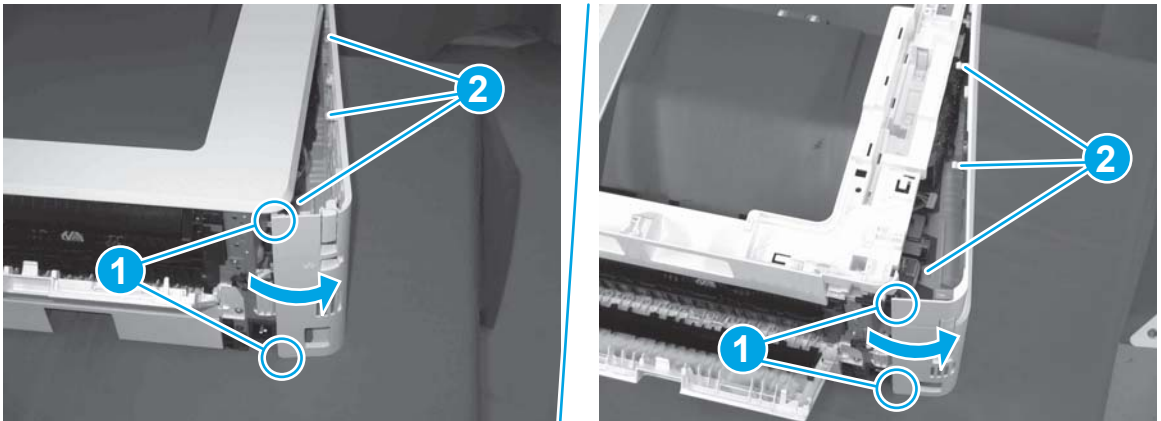

3. At the front of the printer, do one of the following:
 - **M403/M402:** Release two bosses (callout 1), and then remove the cover (callout 2).
 - **M427/M426:** Release one tab (callout 3), two bosses (callout 4), and then remove the cover (callout 5).

CAUTION: Be careful when releasing the upper bosses on the M427/M426 cover. One portion of the cover (callout 6) is fragile and is easily broken.

Figure 1-954 Remove the cover

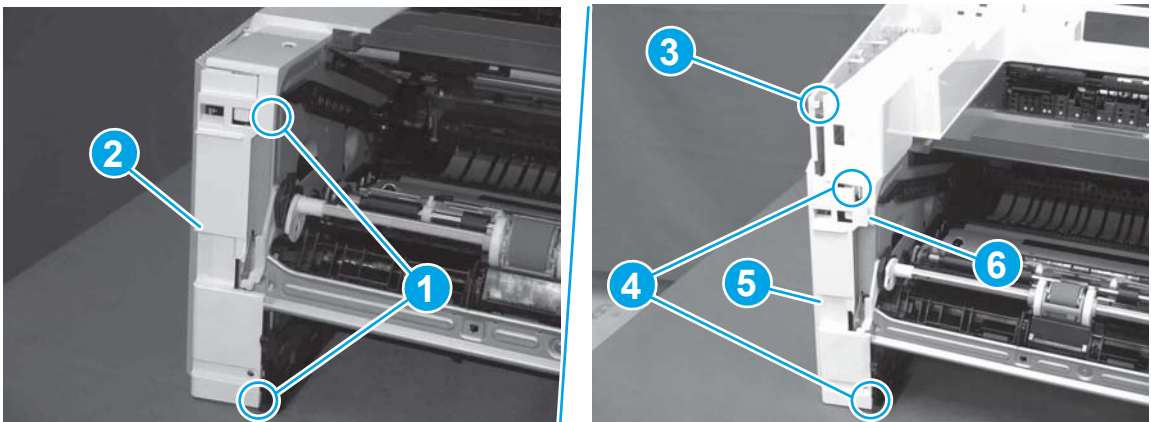

Step 4: Remove the right cover

1. Remove one screw (callout 1).

Figure 1-955 Remove one screw



2. At the front of the printer, release two bosses (callout 1), and then release three tabs (callout 2).

Figure 1-956 Release two bosses and three tabs

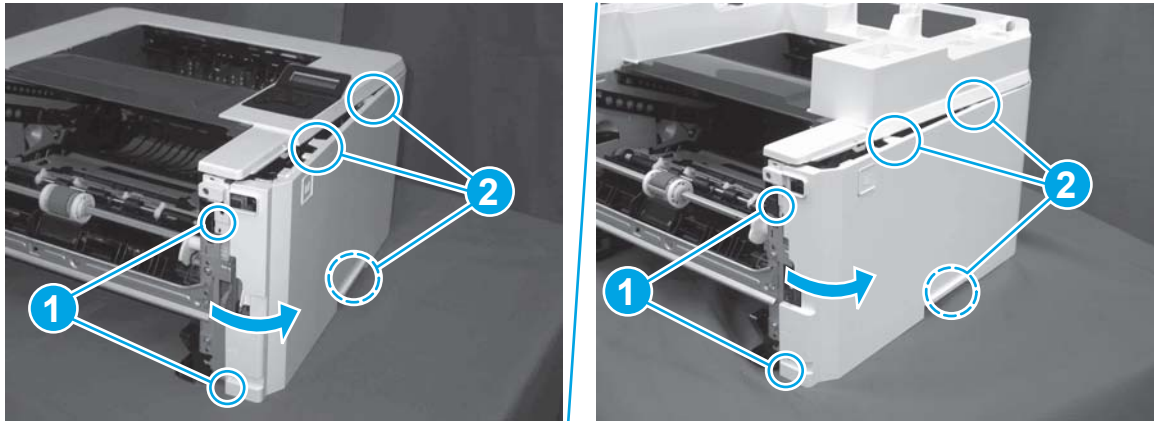

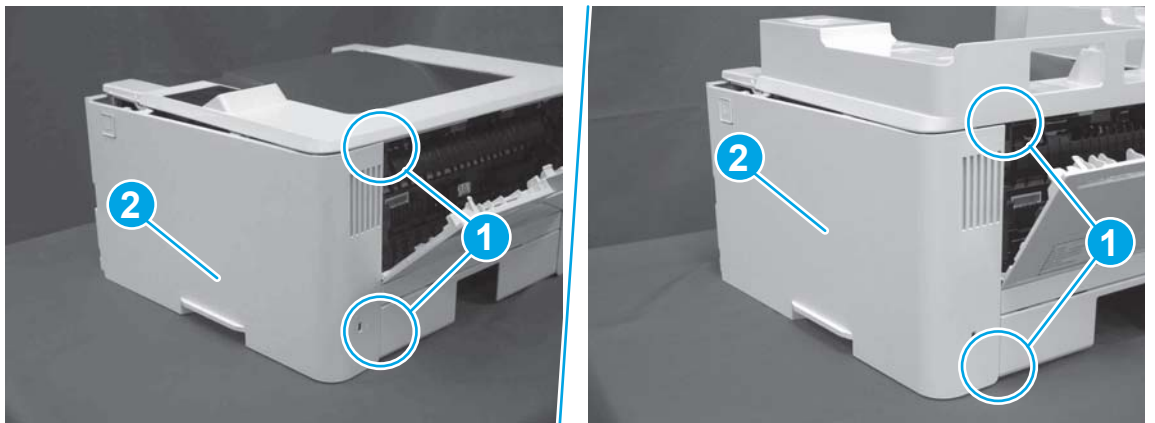

3. Open the rear door, release two bosses (callout 1), and then remove the cover (callout 2).

Figure 1-957 Remove the cover



Step 5: Remove the integrated scanner assembly (M427/M246)

 **NOTE:** The step is for the M427/M246 printer. For the M403/M402, skip this step and go to [Step 8: Remove the top cover \(M403/M402\)](#) on page 541.

 **NOTE:** M427/M426 models only. The integrated scanner assembly (ISA) includes the sub-scanner assembly (SSA) and the automatic document feeder (ADF).

1. Raise the ISA.

Figure 1-958 Raise the ISA

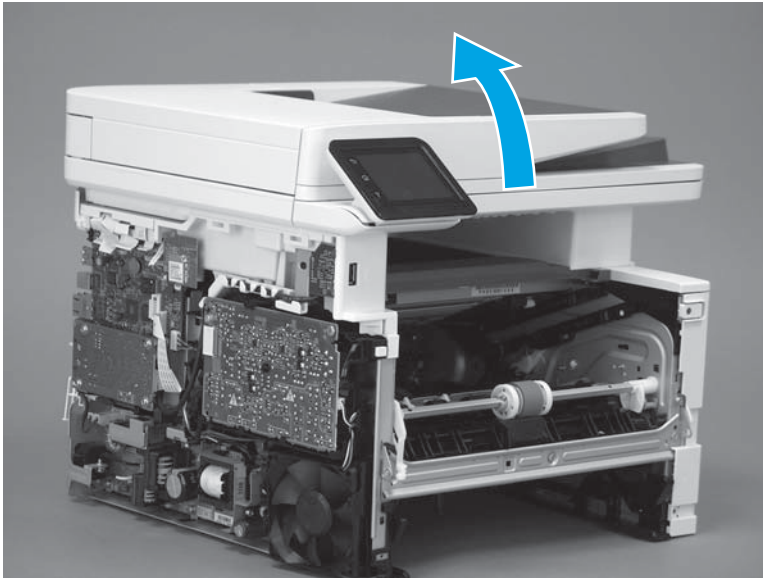

2. Release the ISA flat-flexible cable (FFC) cover (callout 1), and then remove it (callout 2).

Figure 1-959 Remove the ISA FFC cover

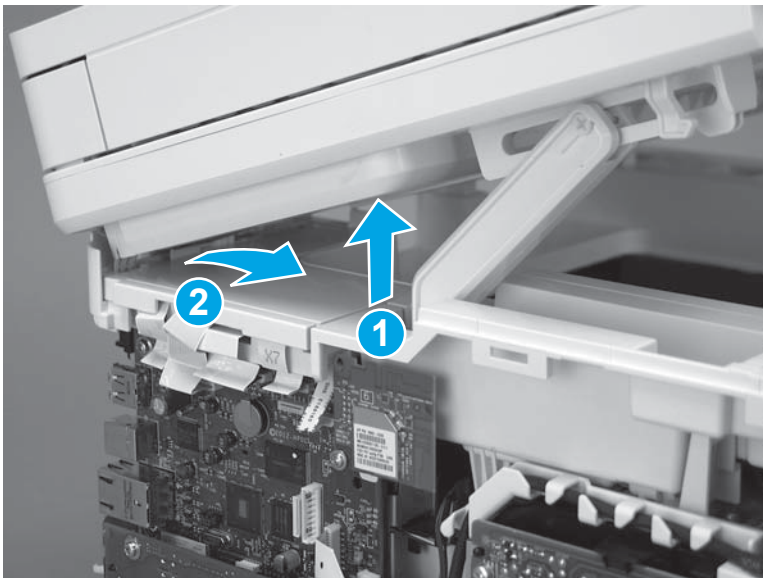

3. Disconnect three FFCs (callout 1), and then remove the ferrite (callout 2) from the holder.

CAUTION: The ferrite is not captive on the FFC. Do not lose the ferrite while handling the ISA.

Figure 1-960 Disconnect three FFCs

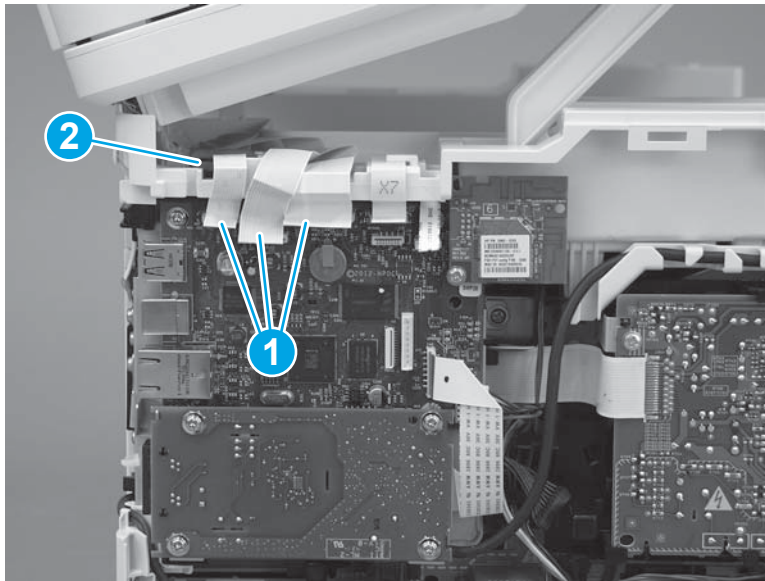

4. Remove one screw (callout 1).

Figure 1-961 Remove one screw

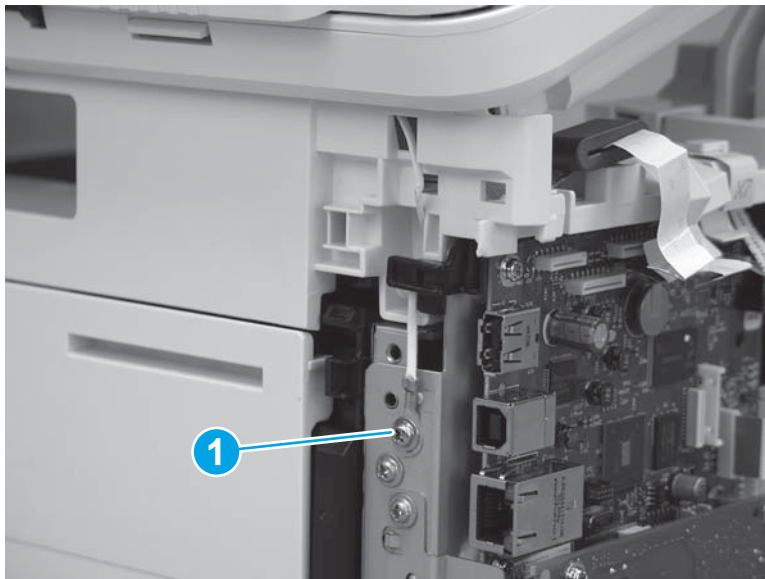

5. Pass the ground wire through the opening in the top cover.

Figure 1-962 Pass the wire through the opening

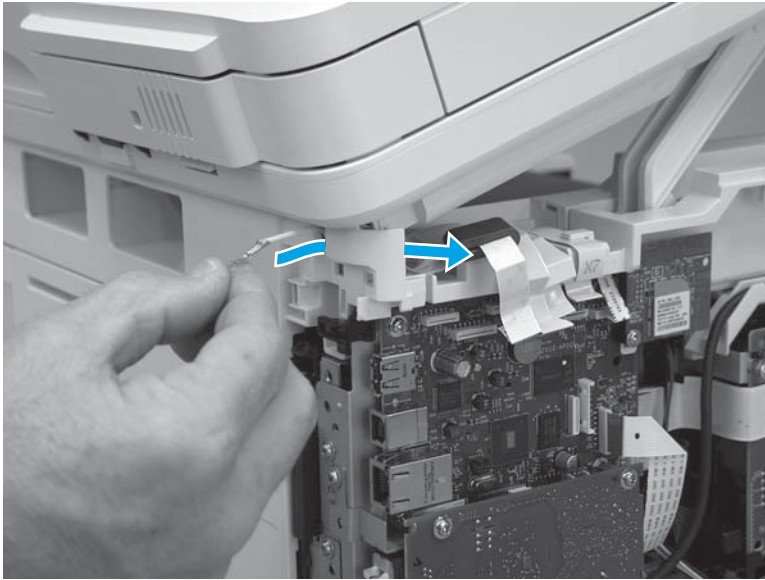

6. Release one tab (callout 1), and then rotate the ISA slider pin (callout 2) towards the front of the printer to release it.

Figure 1-963 Release one tab and rotate the slider pin

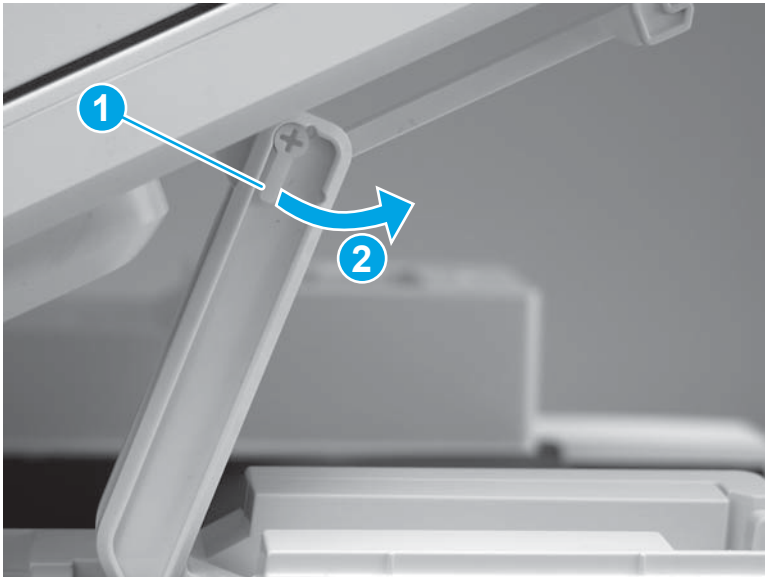

7. Remove the slider pin.

Figure 1-964 Remove the slider pin

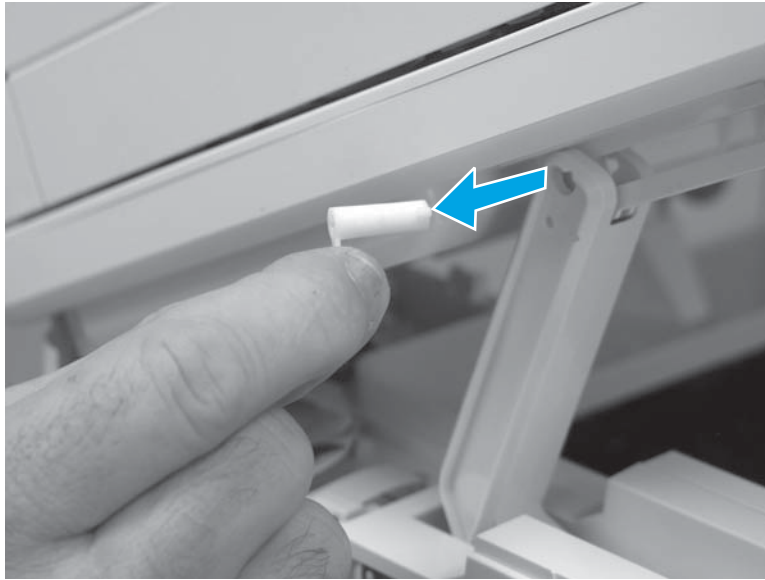

8. Rotate the ISA towards the rear of the printer until it stops.

Figure 1-965 Rotate the ISA towards the rear of the printer



- Slide the ISA as shown to release it.

Figure 1-966 Release the ISA

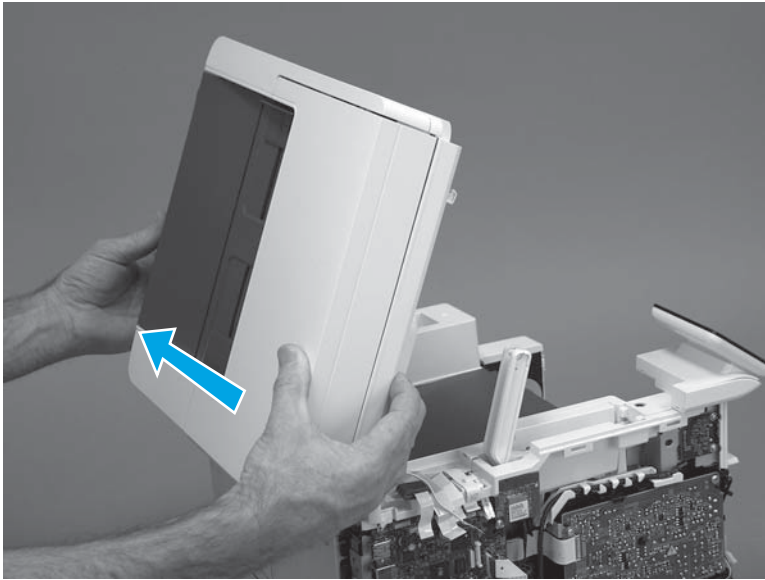

- Remove the ISA.

Figure 1-967 Remove the ISA

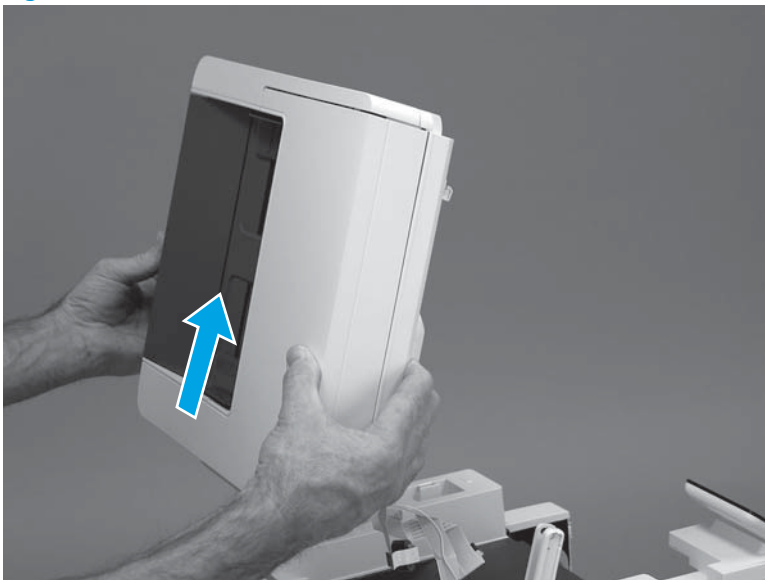

Step 6: Remove the control panel (M427/M246)



NOTE: The step is for the M427/M426 printer. For the M403/M402, skip this step and go to [Step 8: Remove the top cover \(M403/M402\) on page 541](#).

- Disconnect one FFC (callout 1; J114), and then release the FFC from the retainer (callout 2).

Figure 1-968 Disconnect one connector

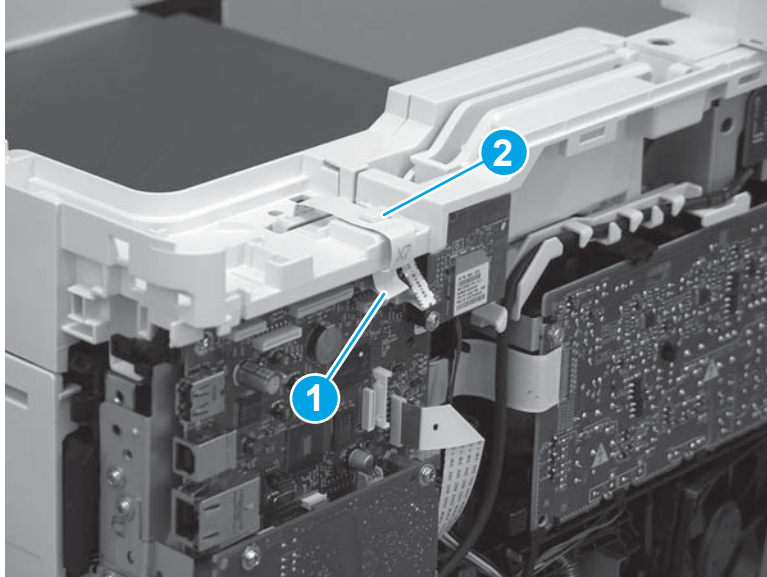

2. Remove one screw (callout 1).

Figure 1-969 Remove one screw

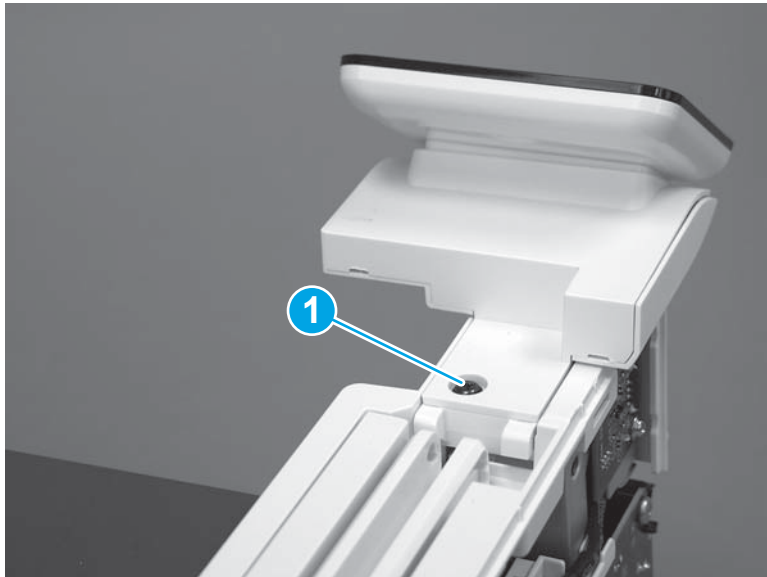

3. Use a small flat-blade screwdriver to release two tabs (callout 1) on the control-panel cable cover.

Figure 1-970 Release two tabs

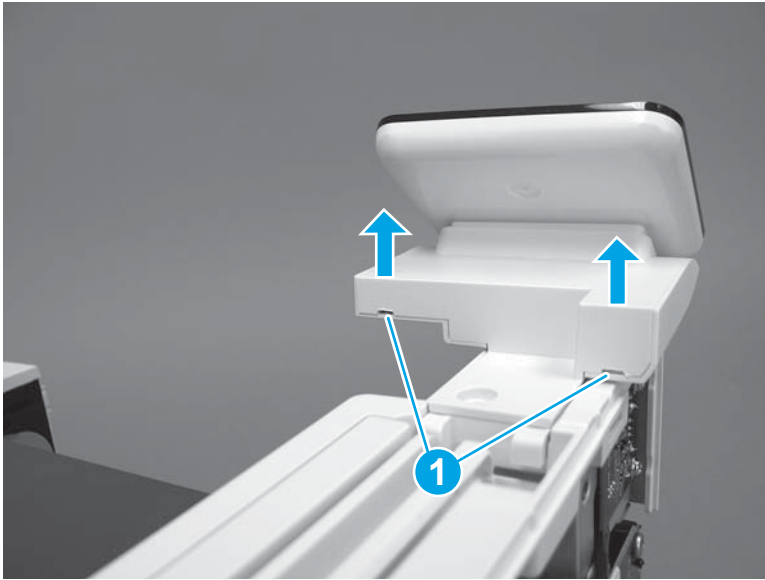

4. Remove the control-panel cable cover.

Figure 1-971 Remove the cover

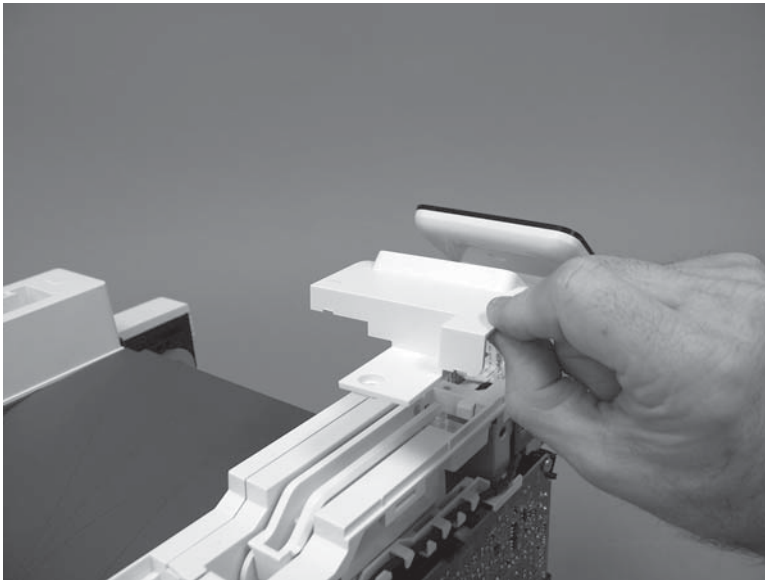

5. Remove one grounding screw (callout 1), and then move the ground cable (callout 2) out of the way.

Figure 1-972 Remove one screw

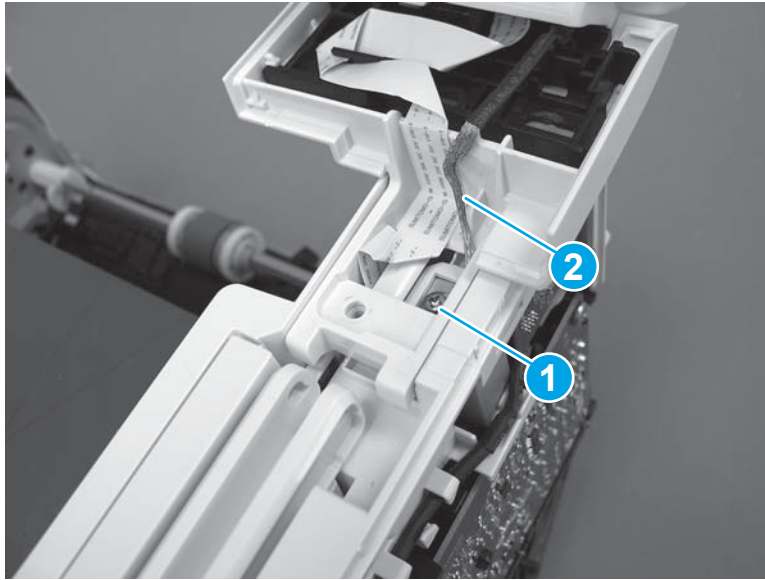

6. Move the FFC out of the way, and then remove two screws (callout 1).

Figure 1-973 Remove two screws

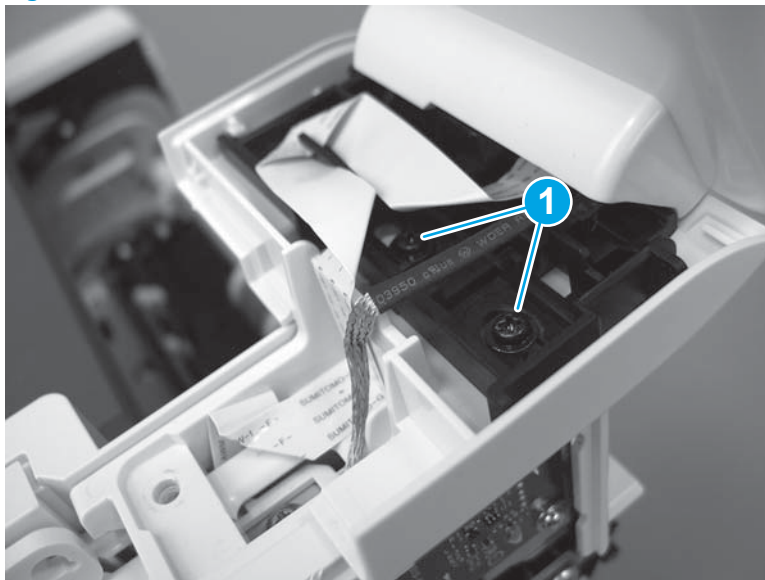

7. Slightly lift up the control-panel assembly to separate it from the top cover.

⚠ CAUTION: The control panel assembly is still connected to the printer by the FFC. Do not attempt to completely remove the assembly.

Figure 1-974 Lift up the control-panel assembly

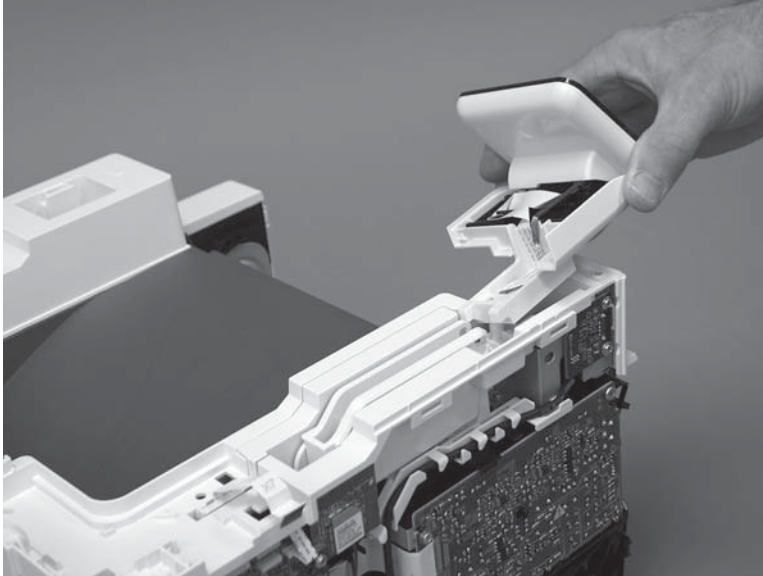

8. Lift up the control-panel FFC cover to remove the control-panel assembly.

Figure 1-975 Remove the control-panel assembly

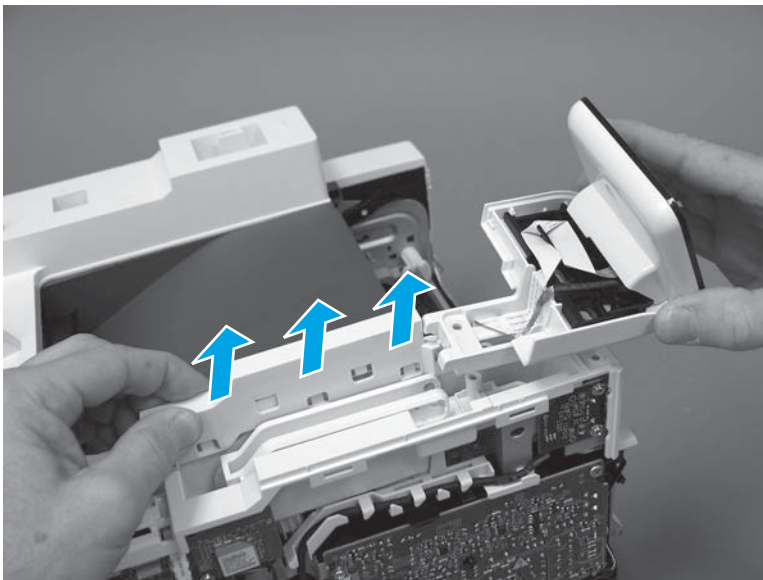

Step 7: Remove the top cover (M427/M426)

📝 NOTE: The step is for the M427/M426 printer. For the M403/M402, skip this step and go to [Step 8: Remove the top cover \(M403/M402\) on page 541](#).

1. Release the USB cable (callout 1) from the cable guide.

Figure 1-976 Remove the USB cable

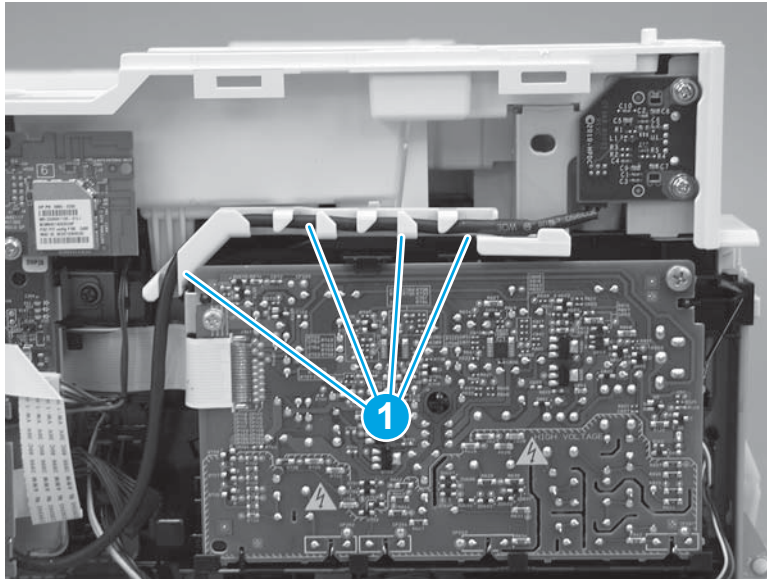

2. Remove five screws (callout 1), release four bosses (callout 2), and then remove the top cover (callout 3).

Figure 1-977 Remove the cover

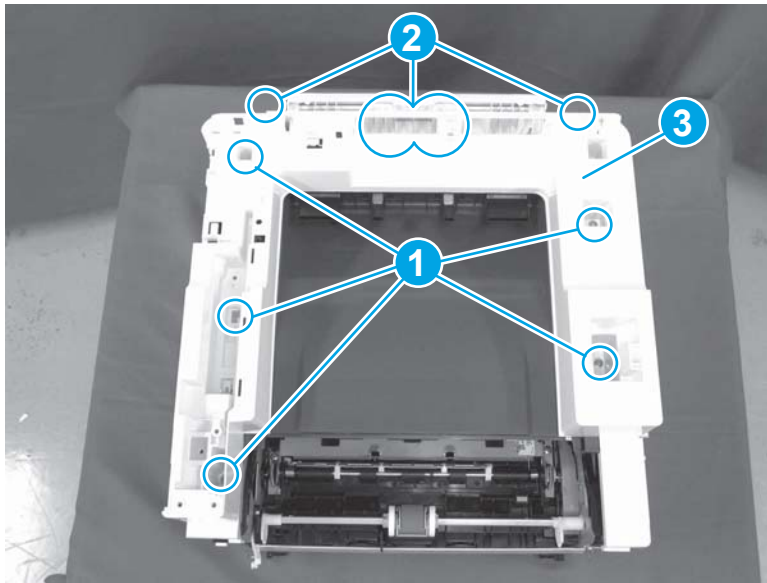

Step 8: Remove the top cover (M403/M402)

 **NOTE:** The step is for the M403/M402 printer. For the M427/M426, skip this step and go to [Step 9: Remove the paper delivery tray \(output bin\) on page 543.](#)

1. Remove one screw (callout 1).

Figure 1-978 Remove one screw



2. At the right side of the printer, release the one boss (callout 1), and then release one tab (callout 2).

Figure 1-979 Release one boss and one tab

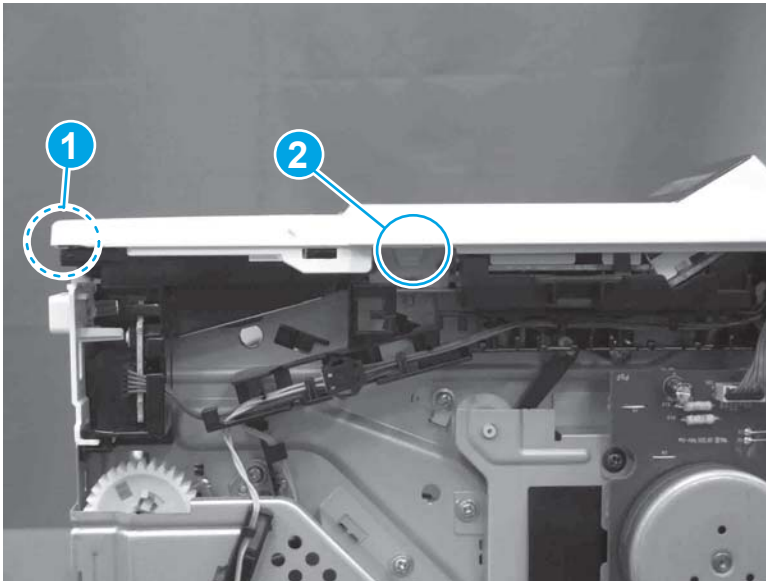

3. Release four tabs (callout 1), release four bosses (callout 2), and then remove the top cover (callout 3).



 **TIP:** Open the rear door to make releasing the bosses (callout 3) easier.

Figure 1-980 Remove the cover

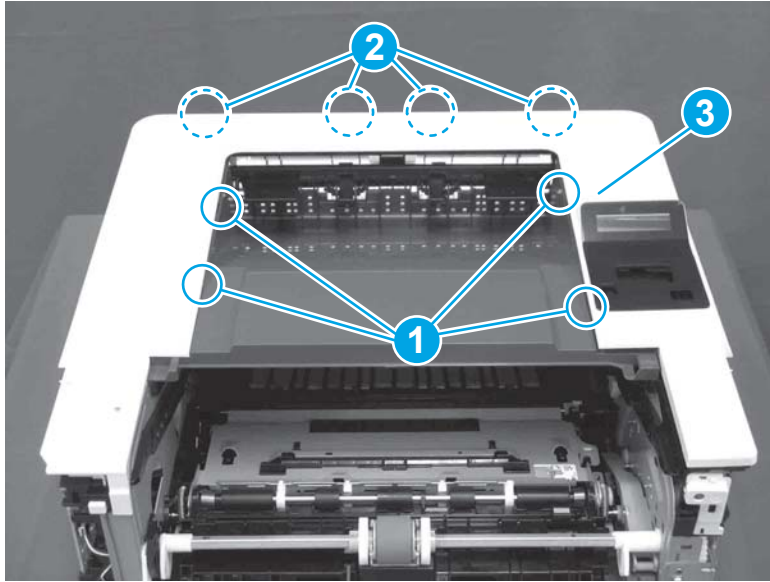

Step 9: Remove the paper delivery tray (output bin)

 **NOTE:** This procedure shows the M403/M402 model, however, the paper delivery tray (output bin) removal is similar for the M427/M426 printer.

- ▲ Release two bosses (callout 1), release two tabs (callout 2), and then remove the paper delivery tray (output bin; callout 3).

Figure 1-981 Release two tabs

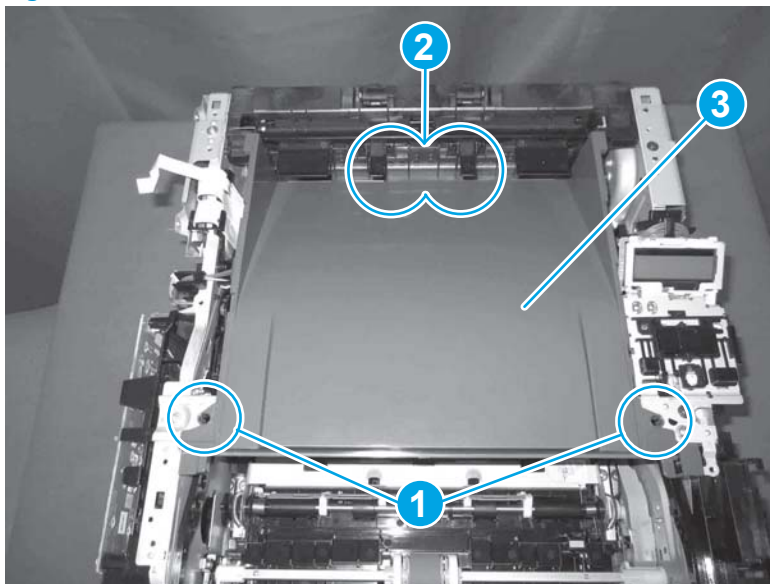

Step 10: Remove the laser scanner assembly

 **NOTE:** The M403/M402 product is shown in this procedure. However, the procedure is valid for the M427/M426 laser scanner assembly.

1. Disconnect one flat-flexible cable (FFC) (callout 1), and one connector (callout 2).

 **Reinstallation tip:** Transfer the antistatic foam pad (callout 2) from the discarded laser/scanner assembly to the replacement assembly.

Figure 1-982 Disconnect one FFC and one connector



2. Remove four screws (callout 1), and then remove the laser scanner assembly.

Figure 1-983 Remove the laser scanner

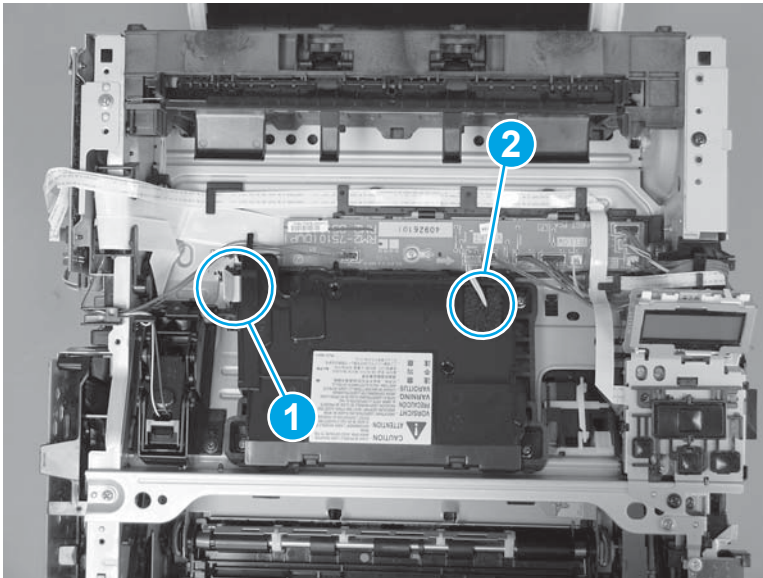
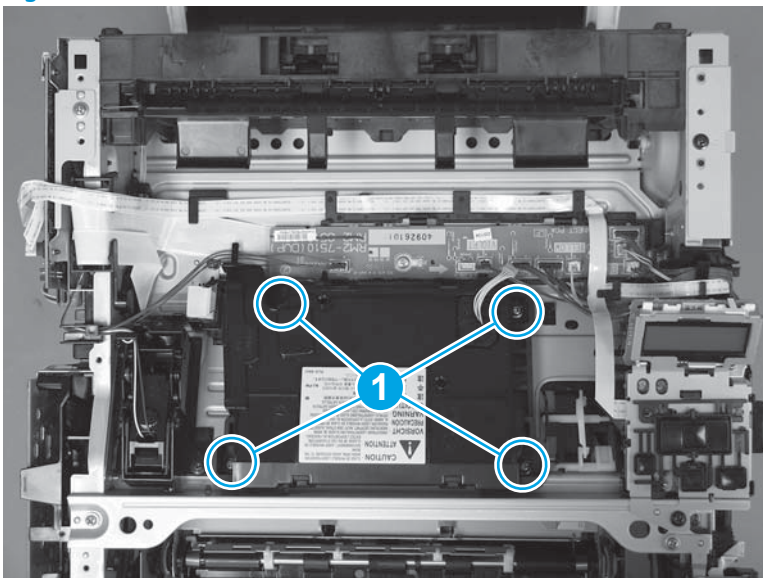

Step 11: Unpack the replacement assembly

Unpack the replacement part from the packaging.

 **NOTE:** HP recommends responsible disposal of the defective part.

Figure 1-984 Recycle and unpack

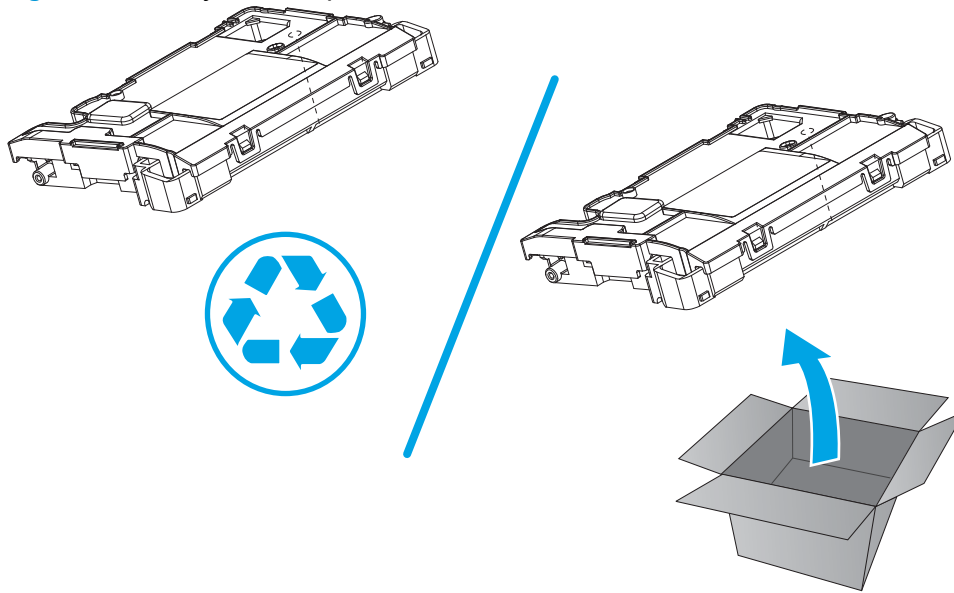

Step 12: Install the laser scanner assembly

 **NOTE:** The M403/M402 product is shown in this procedure. However, the procedure is valid for the M427/M426 laser scanner assembly.

1. Position the laser scanner assembly in the printer, connect one FFC (callout 1) and one connector (callout 2).

 **Reinstallation tip:** Transfer the antistatic foam pad (callout 2) from the discarded laser scanner assembly to the replacement assembly.

Figure 1-985 Connect one FFC and one connector



2. Install four screws (callout 1).

Figure 1-986 Install the laser scanner

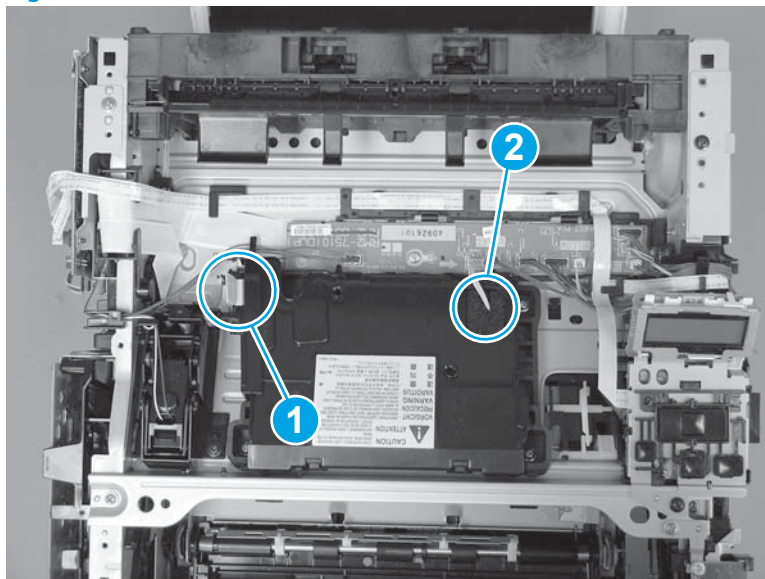
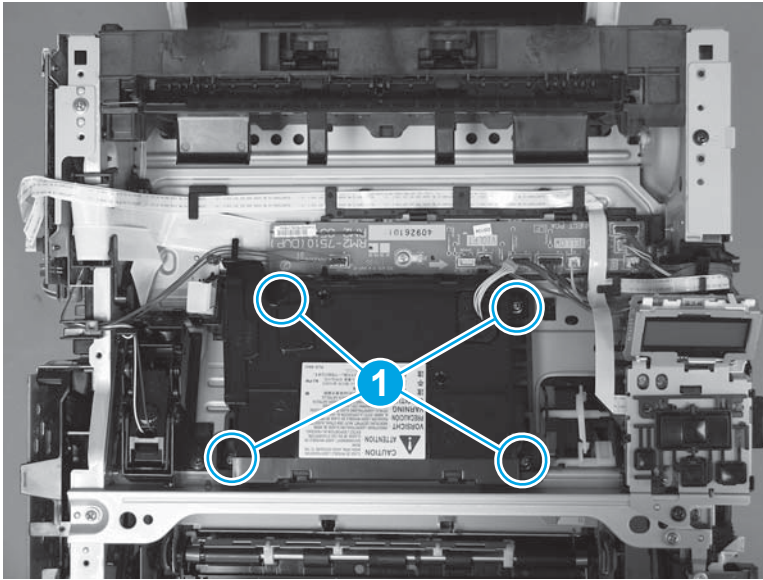

Step 13: Install the paper delivery tray (output bin)



NOTE: This procedure shows the M403/M402 model, however, the paper delivery tray (output bin) removal is similar for the M427/M426 printer.

- ▲ Position the remove the paper delivery tray (output bin; callout 1) on the printer, engage two tabs (callout 2), and then engage two bosses (callout 3).

Figure 1-987 Engage two tabs

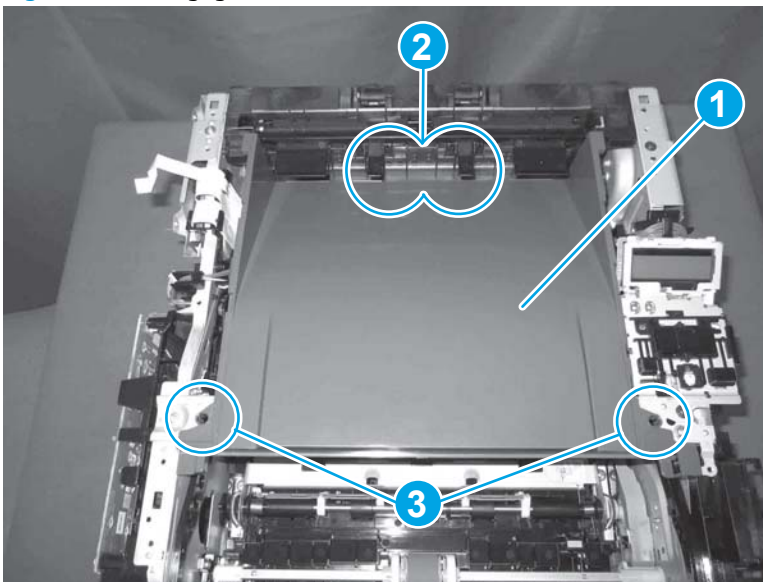

Step 14: Install the top cover (M403/M402)



NOTE: The step is for the M403/M402 printer. For the M427/M426, skip this step and go to [Step 15: Install the top cover \(M427/M426\) on page 548](#).

1. Position the rear edge of the cover on the printer.

Figure 1-988 Install the cover

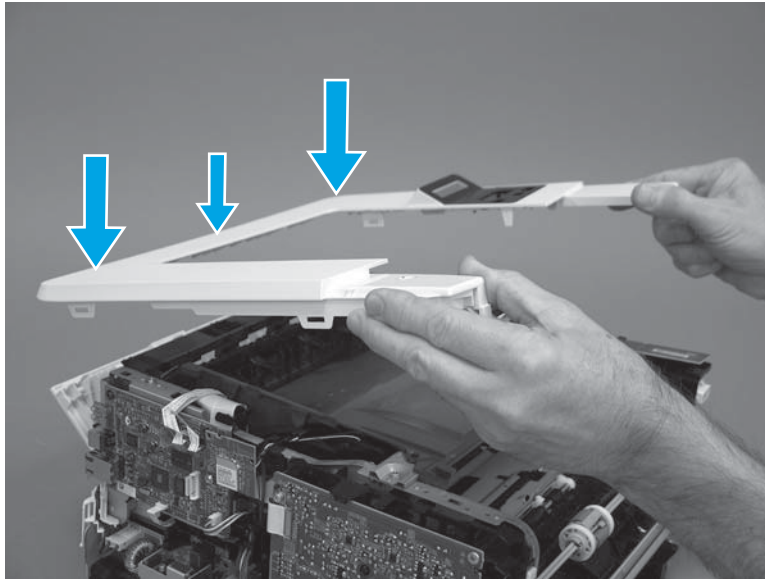

2. Engage four bosses (callout 1), rotate the front of the cover down (callout 2) and onto from the printer, and then engage four tabs (callout 3).

Figure 1-989 Engage four bosses and tabs

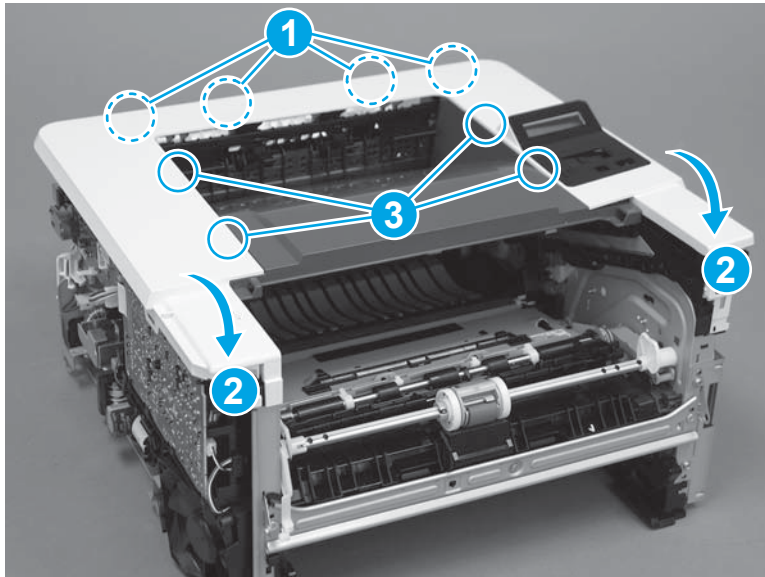

3. At the right side of the printer, engage the one boss and one tab (callout 1).

Figure 1-990 Engage one boss and one tab

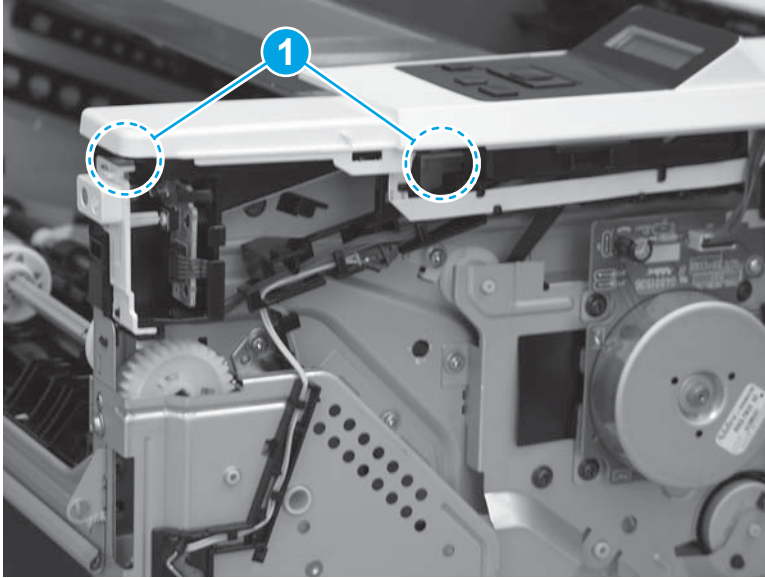

4. Install one screw (callout 1).

Figure 1-991 Install one screw

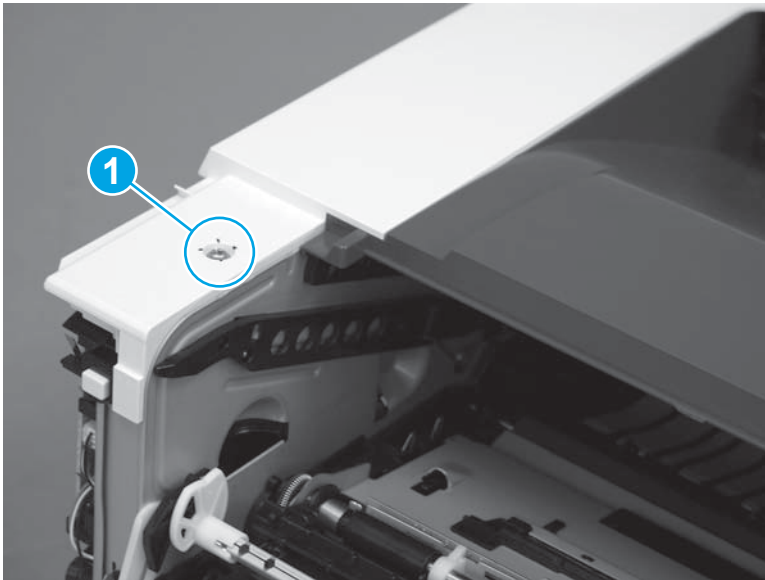

Step 15: Install the top cover (M427/M426)

 **NOTE:** The step is for the M427/M426 printer. For the M403/M402, skip this step and go to [Step 18: Install the right cover on page 560](#).

1. Position the rear edge of the top cover on the printer.

Figure 1-992 Install the cover

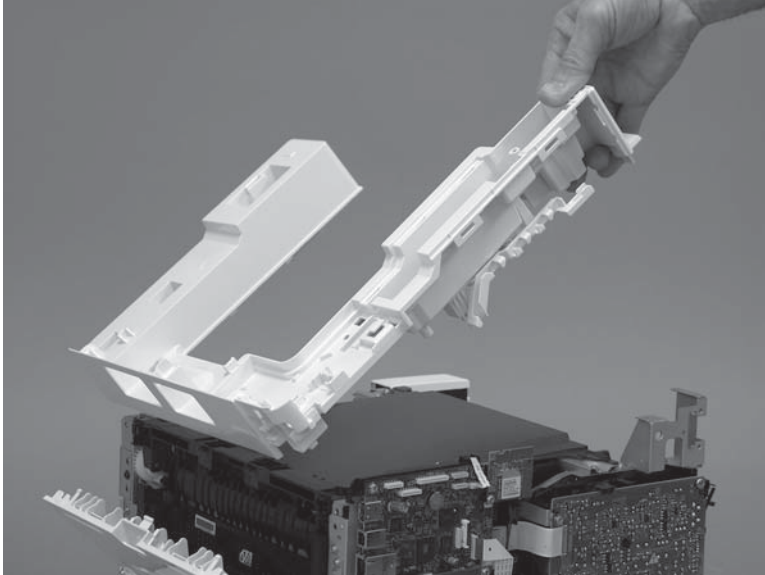

2. Engage four bosses (callout 1).

Figure 1-993 Engage four bosses

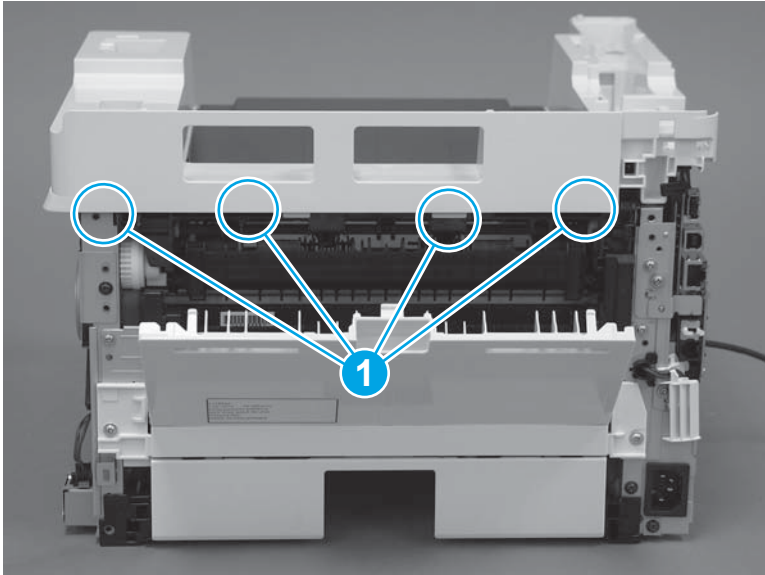

3. Rotate the front edge of the cover down.

Figure 1-994 Rotate the front edge of the cover down

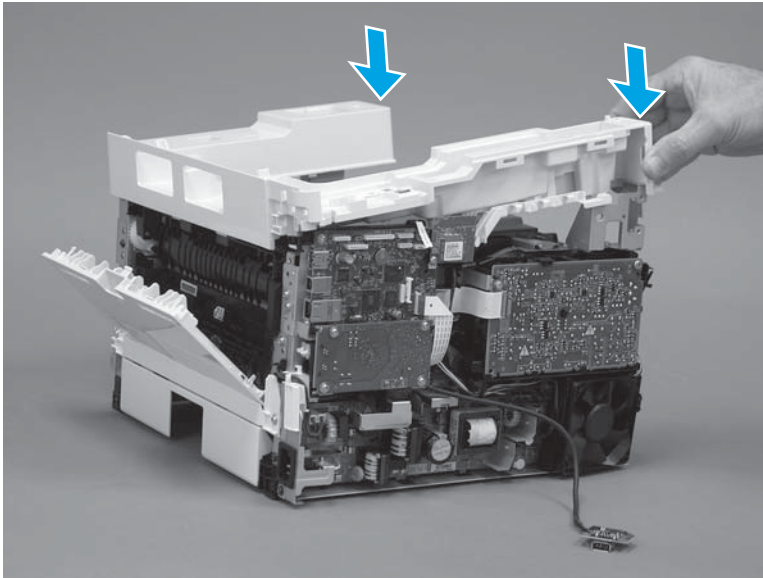

4. Install the USB cable (callout 1) in the guide.

Figure 1-995 Install the USB PCA

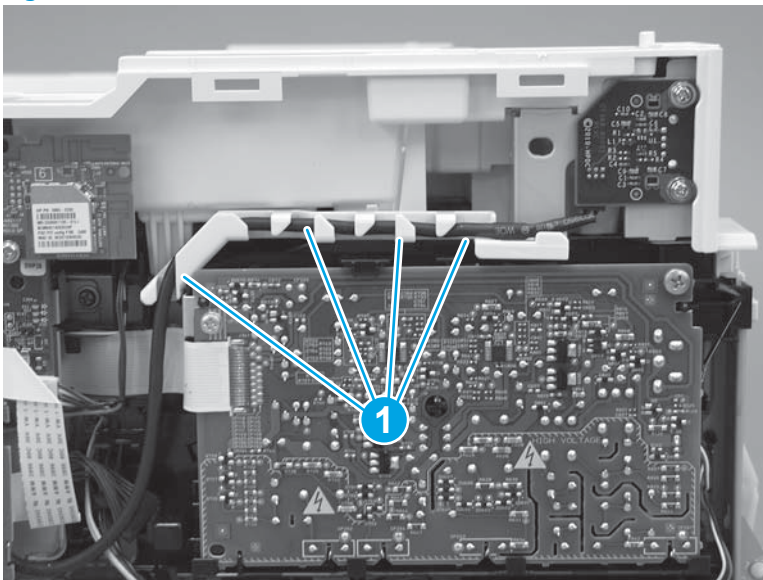

5. Install five screws (callout 1).

Figure 1-996 Install five screws

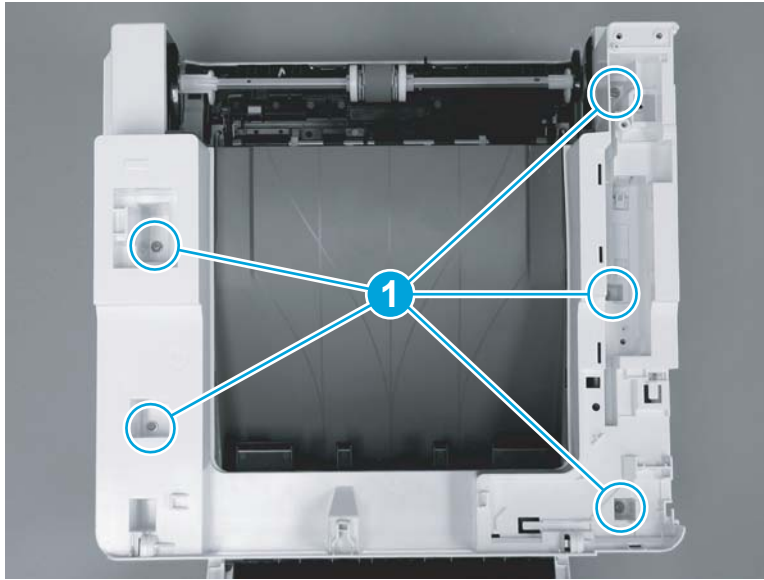

Step 16: Install the control panel (M427/M246)

 **NOTE:** The step is for the M427/M426 printer. For the M403/M402, skip this step and go to [Step 18: Install the right cover on page 560](#).

1. Slide the control-panel FFC cover into the slot in the top cover (next to the document feeder support arm) to install it.

Figure 1-997 Install the control-panel FFC cover

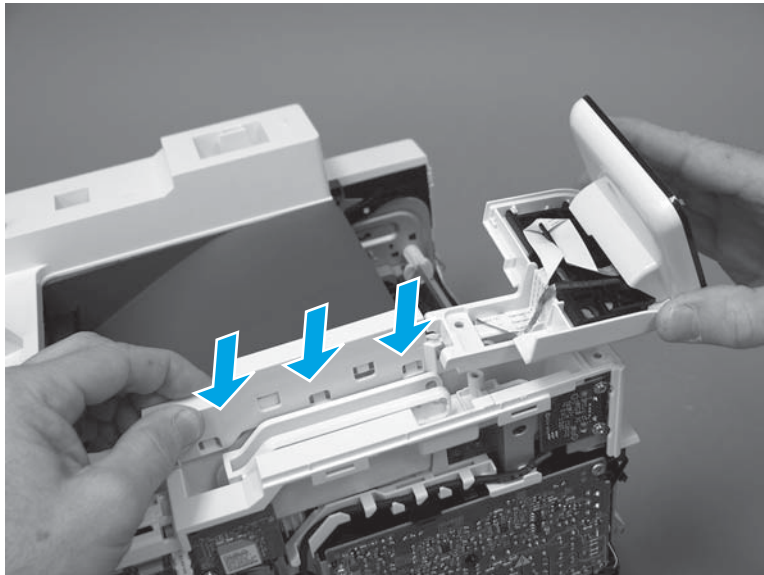

2. Install the control-panel assembly on the top cover.

Figure 1-998 Install the control-panel assembly

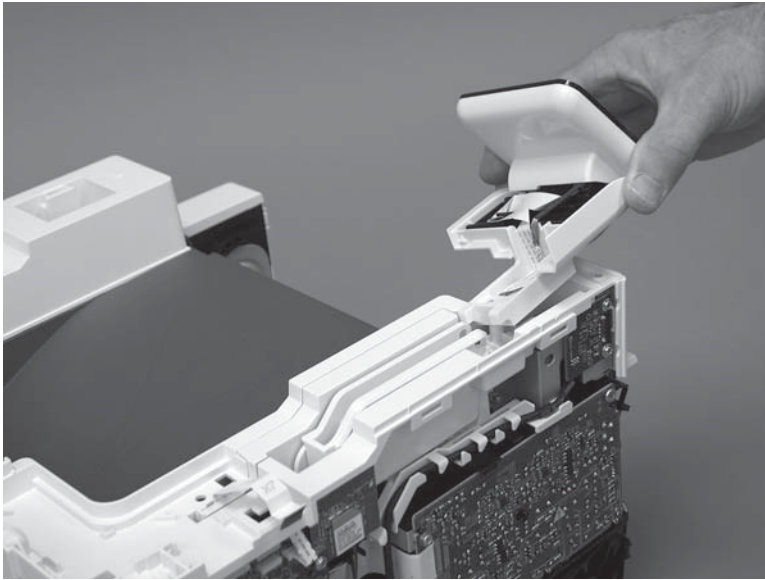

3. Move the FFC out of the way, and then install two screws (callout 1).

Figure 1-999 Install two screws

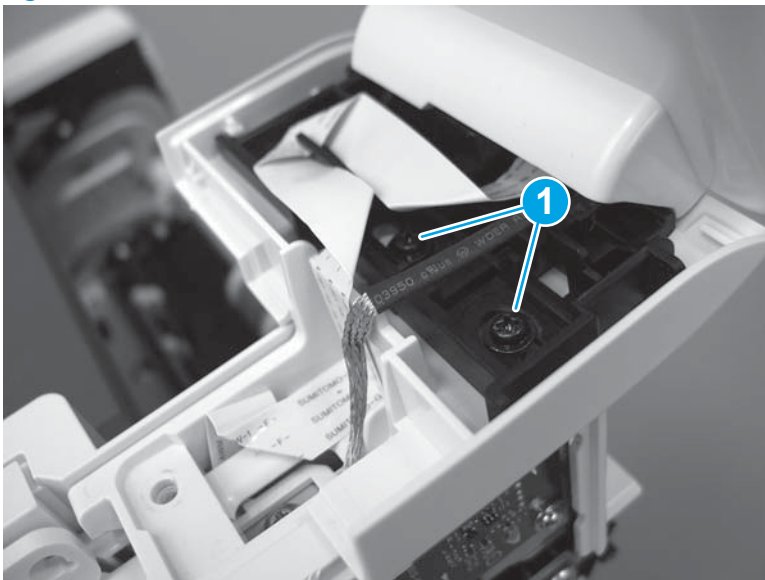

4. Install one grounding screw (callout 1), and then make sure that the ground cable (callout 2) is properly routed.

Figure 1-1000 Remove one screw

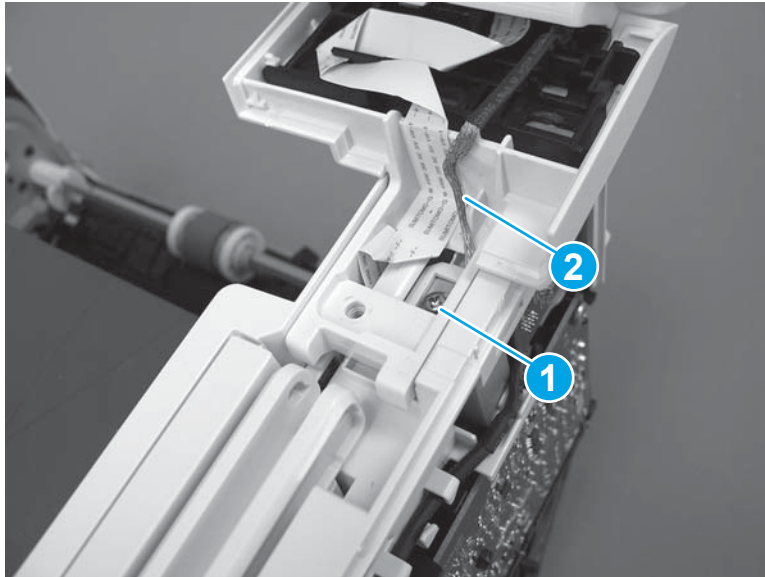

5. Install the control-panel cable cover.

Figure 1-1001 Install the cover

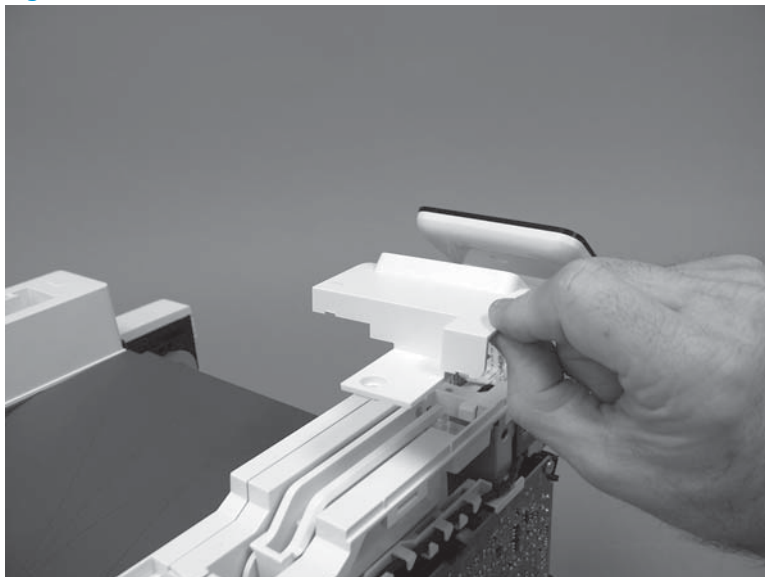

6. Make sure that the two tabs (callout 1) on the cover snap into place.

Figure 1-1002 Engage two tabs

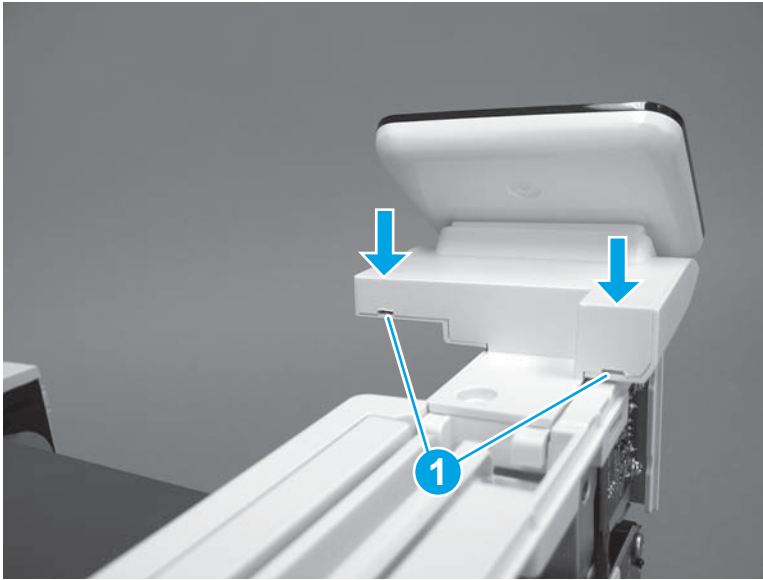

7. Install one screw (callout 1).

Figure 1-1003 Install one screw

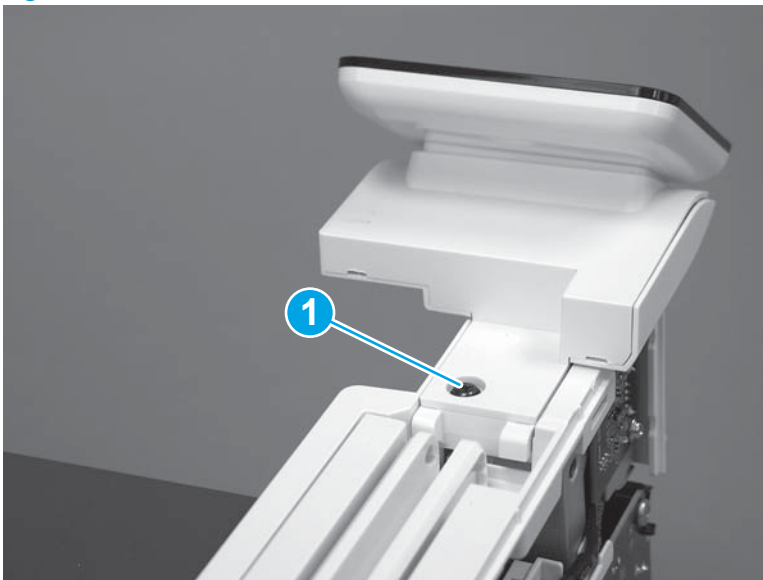

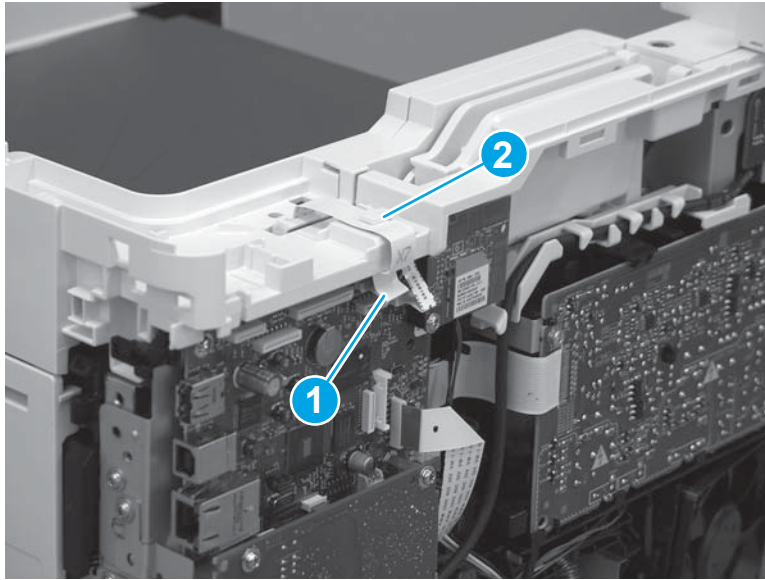

8. Install the FFC in the retainer (callout 1), and then connect one FFC (callout 2; J114).

Figure 1-1004 Connect one connector



Step 17: Install the integrated scanner assembly (M427/M246)

 **NOTE:** The step is for the M427/M426 printer. For the M403/M402, skip this step and go to [Step 18: Install the right cover on page 560](#).

 **NOTE:** M427/M426 models only. The integrated scanner assembly (ISA) includes the sub-scanner assembly (SSA) and the automatic document feeder (ADF).

1. Position the ISA on the printer.

Figure 1-1005 Position the ISA on the printer

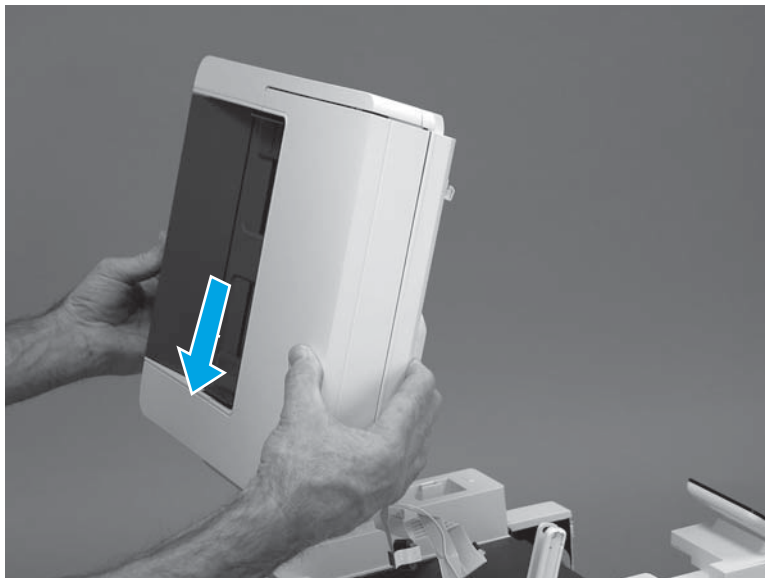

2. Engage the hinge pins on the ISA with the holders in the top cover (callouts 1/2), and then slide the ISA as shown to engage them

Figure 1-1006 Engage the hinge pins with the holders

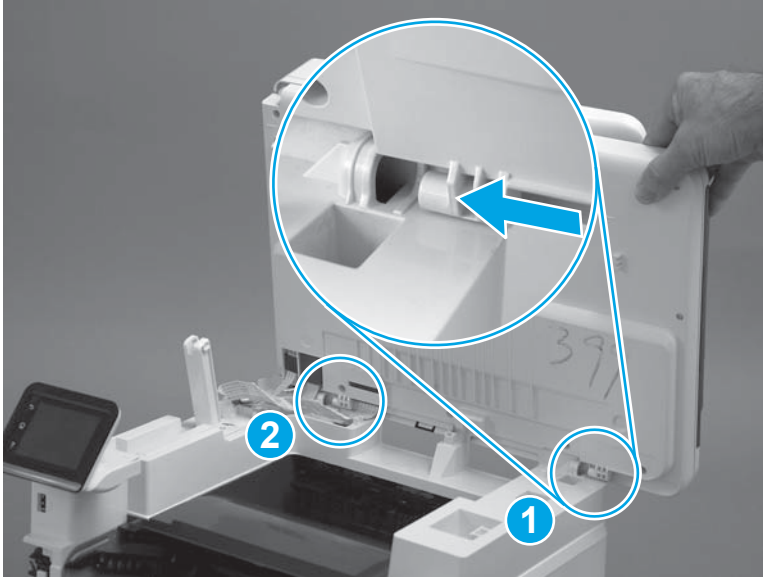

3. Rotate the ISA towards the front of the printer until it rests on the ISA lift assembly (callout 1).

Figure 1-1007 Rotate the ISA towards the front of the printer



4. Pass the ground wire through the opening in the top cover.

Figure 1-1008 Pass the wire through the opening

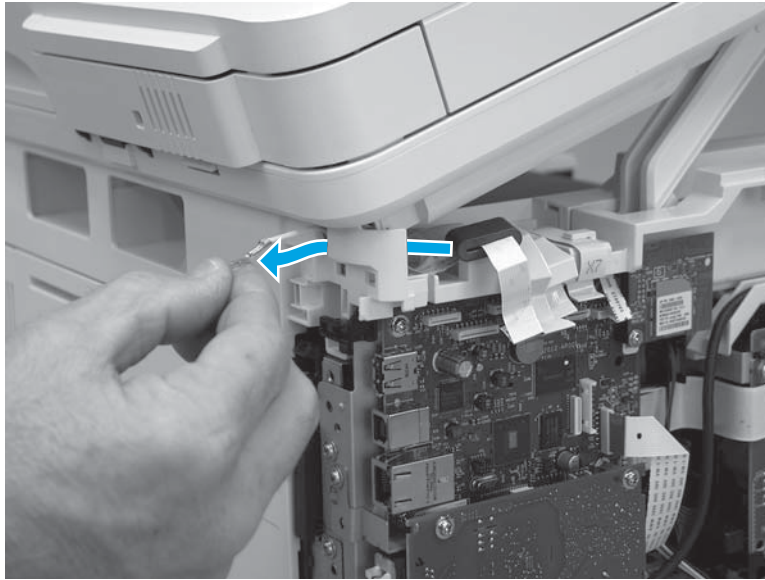

5. Install one screw (callout 1).

Figure 1-1009 Install one screw

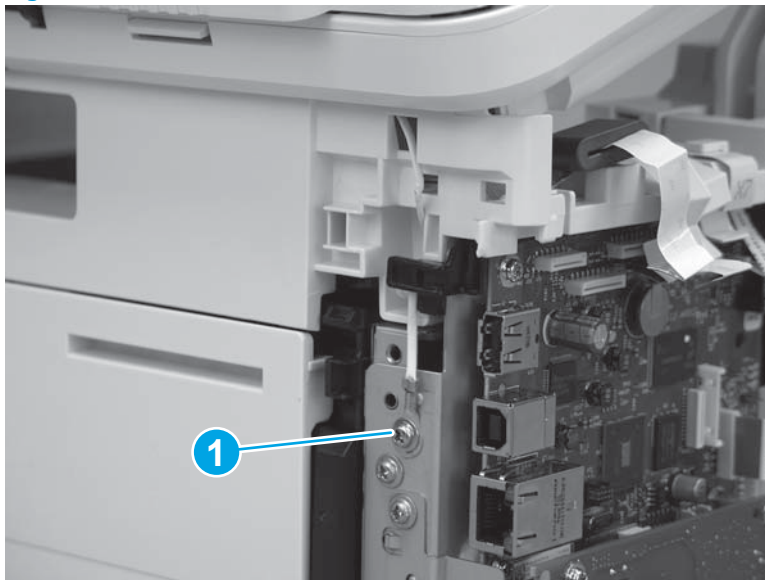

6. Install the ISA lift assembly slider pin.

 **Reinstallation tip:** Align the keyed portion of the locking pin with the slot and hole in the support arm.

Figure 1-1010 Install the slider pin



7. Rotate the slider pin (callout 1) towards the rear of the printer until the tab (callout 2) snap into place.

Figure 1-1011 Secure the slider pin

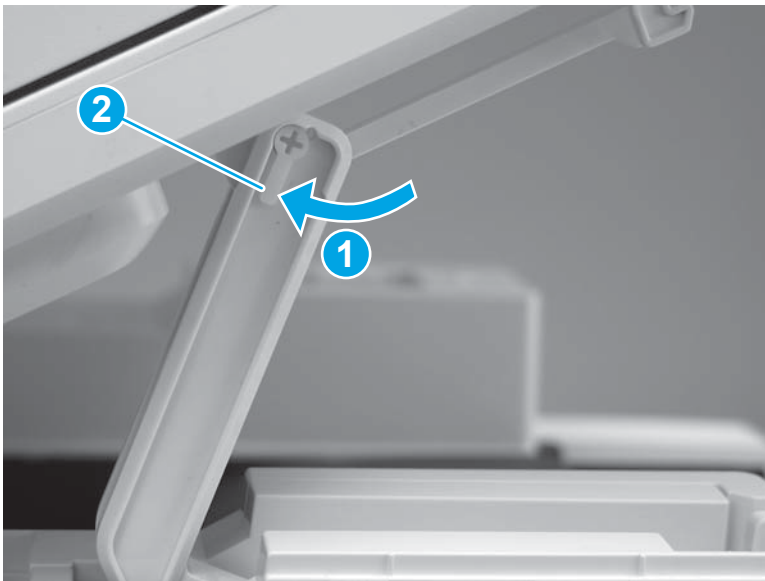

8. Install the ferrite (callout 1) in the holder, and then connect three FFCs (callout 2).

Figure 1-1012 Connect three FFCs

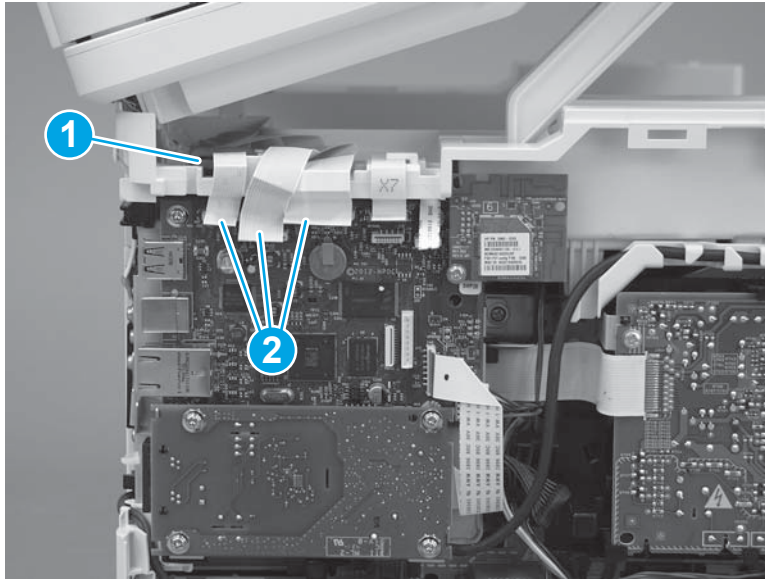

9. Position the rear edge of the ISA flat-flexible cable (FFC) cover on the printer (callout 1), and then rotate it down (callout 2) until it snaps into place.

Figure 1-1013 Install the ISA FFC cover

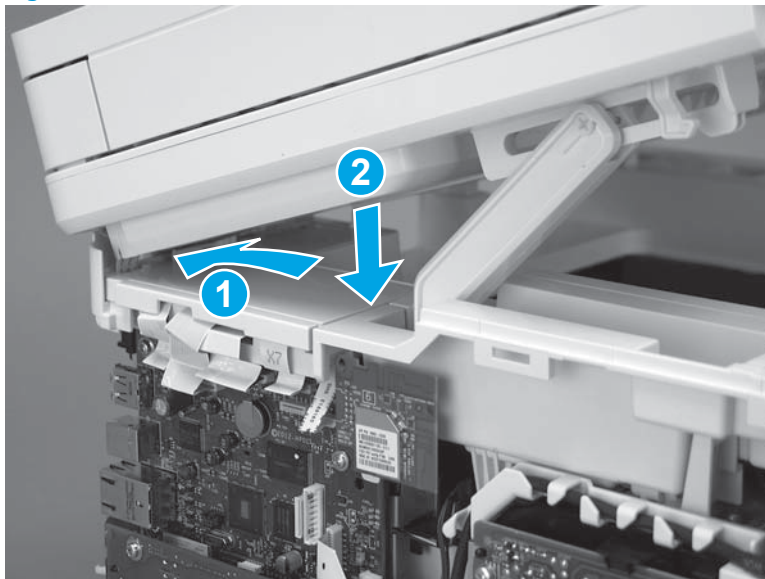

10. Lower the ISA.

Figure 1-1014 Lower the ISA

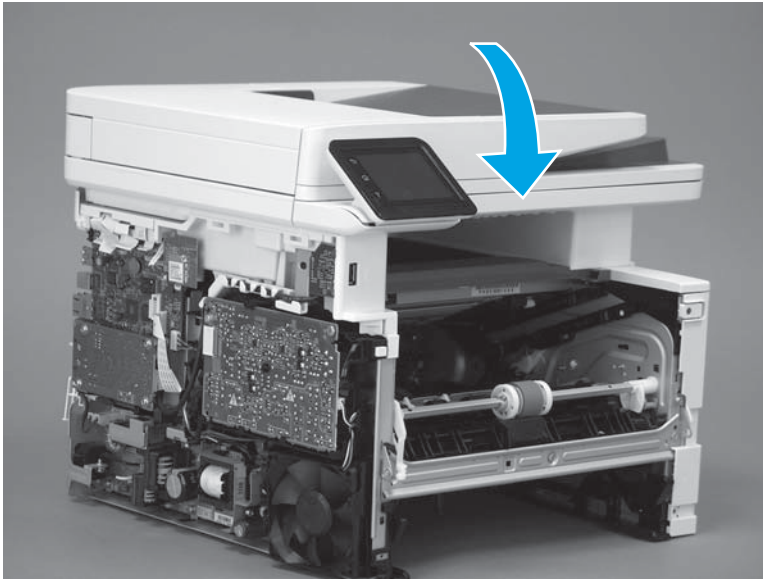

Step 18: Install the right cover

1. Position the cover (callout 1) on the printer, and then engage two bosses (callout 2).

Figure 1-1015 Install the cover

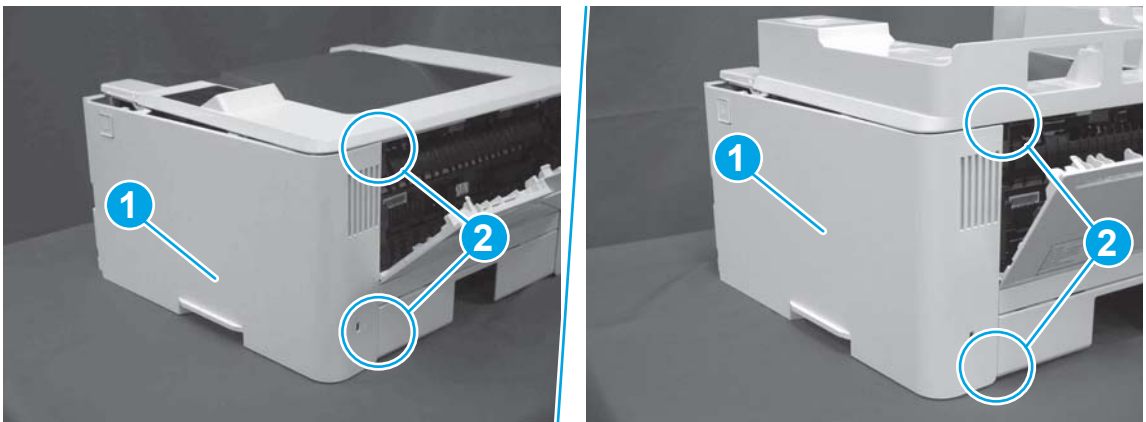

2. Rotate the front of the cover onto the printer (callout 1), engage three (callout 2) tabs, and then engage two bosses (callout 3).

Figure 1-1016 Engage two bosses and one tab

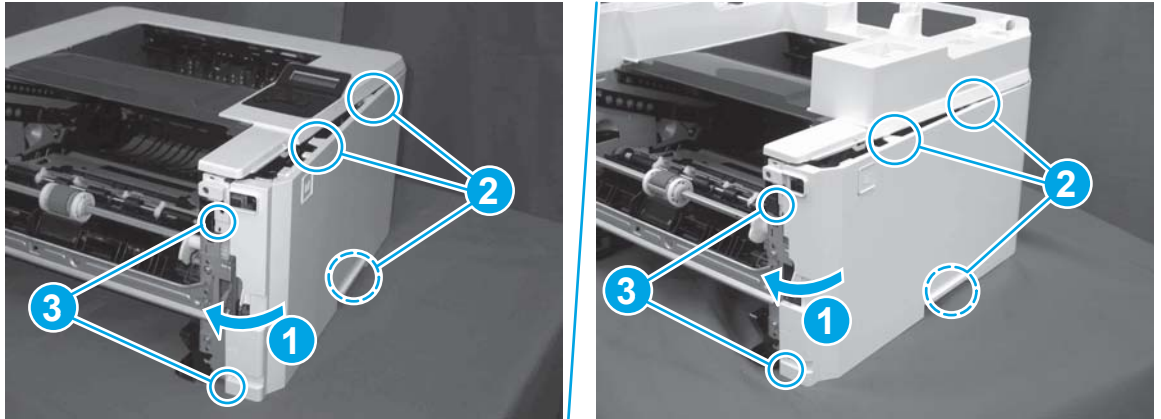

3. Make sure that the power switch (callout 1) and cartridge door assembly button (callout 2) correctly function.

 **NOTE:** Remove, and then reinstall the cover if the switch or button does not correctly function.

Figure 1-1017 Check the power switch and cartridge door assembly button

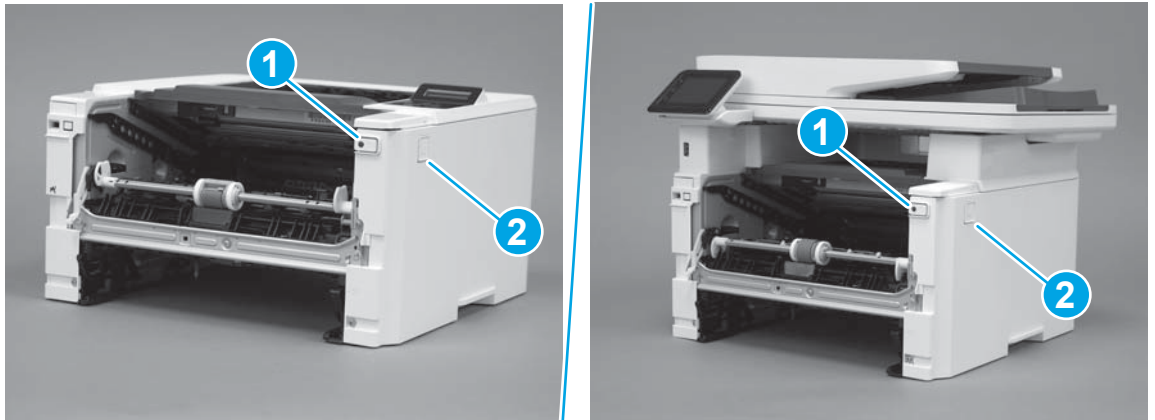

4. Install one screw (callout 1).

Figure 1-1018 Install one screw



Step 19: Install the left cover

1. At the front of the printer, do one of the following:
 - **M403/M402:** Position the cover on the printer (callout 1), and then engage two bosses (callout 2).
 - **M427/M426:** Position the cover on the printer (callout 3), engage one tab (callout 4), and then engage two bosses (callout 4).

Figure 1-1019 Install the cover

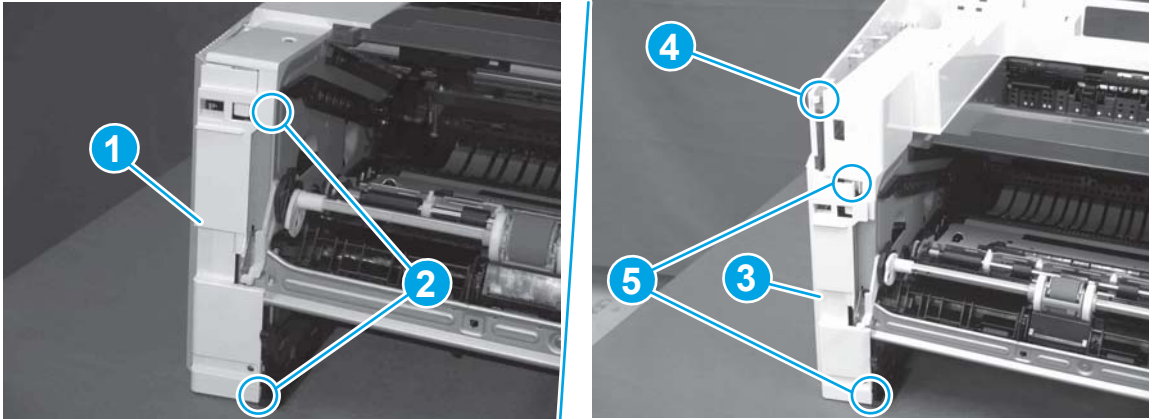

2. Carefully rotate the rear of the cover onto the printer (callout 1), engage three tabs (callout 2), and then engage two bosses (callout 3).

Figure 1-1020 Engage three tabs and two bosses

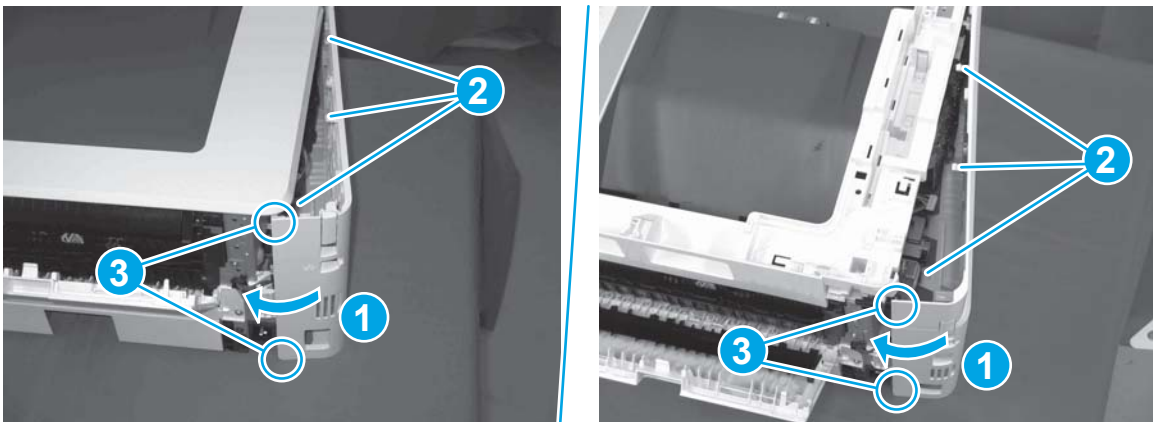

3. Install one screw (callout 1).

Figure 1-1021 Install one screw

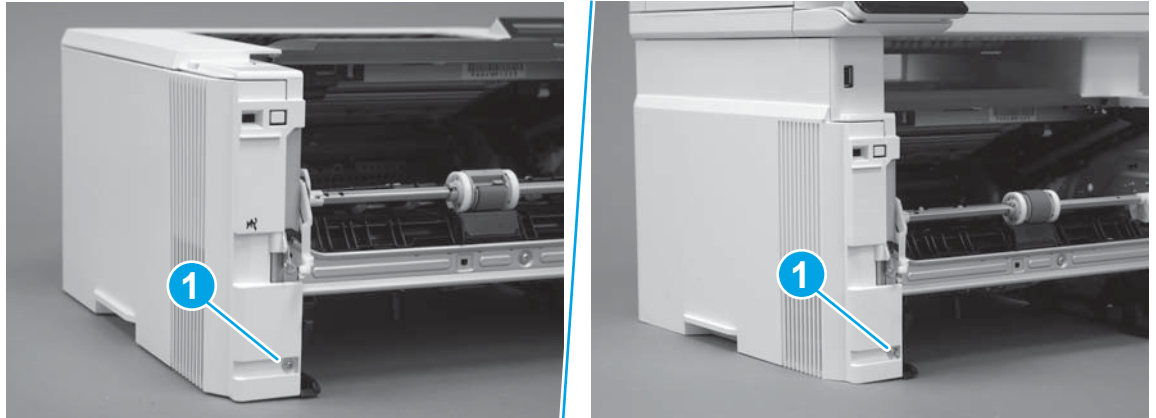

Step 20: Install the cartridge door assembly

 **Reinstallation tip:** After a replacement door is installed, make sure to install the nameplate (supplied in the kit) corresponding to the printer name on the door.

1. Position the door close to the printer, and then engage the keyed pin on the left-side retainer arm with the hole in the door.

Figure 1-1022 Engage the left-side retainer arm

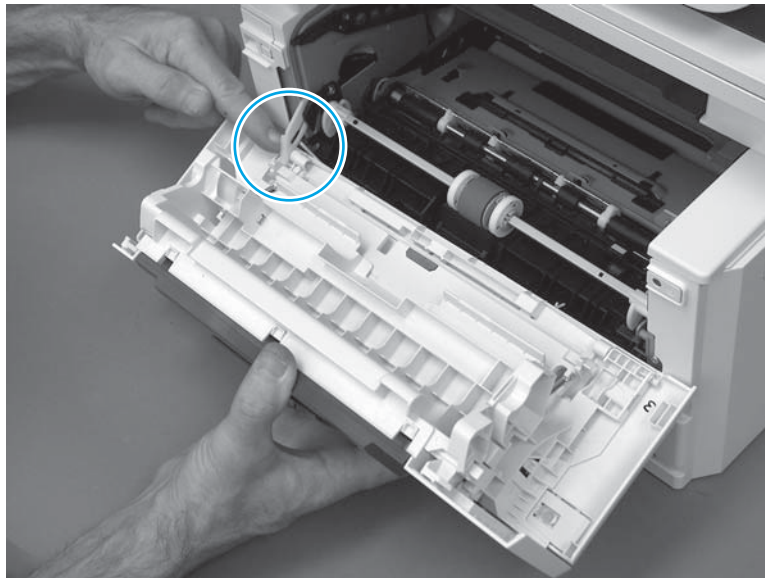

2. Engage the right-side door hinge pin with the hole in the chassis (callout 1).

Figure 1-1023 Install the door

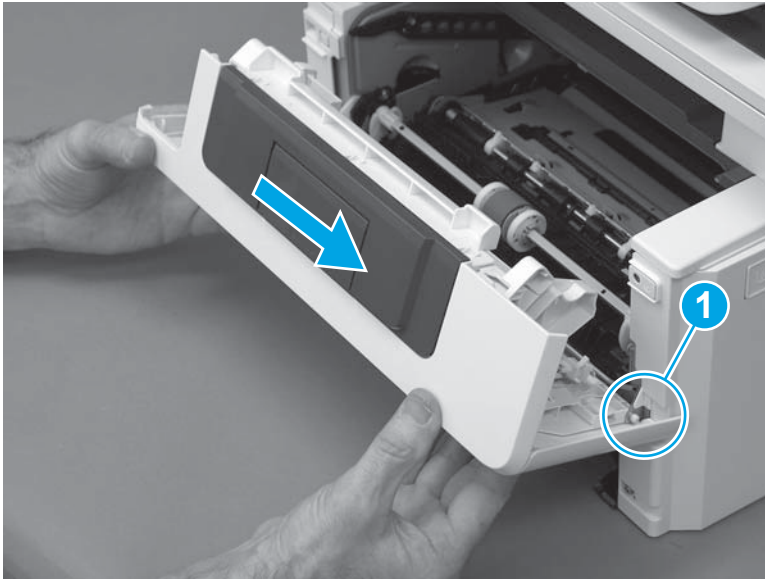

3. Install the link (callout 1).

 **IMPORTANT:** Make sure that the link snaps into place on the arm (callout 2). The link actuates the fuser pressure-release mechanism.

Figure 1-1024 Install the pressure-release link

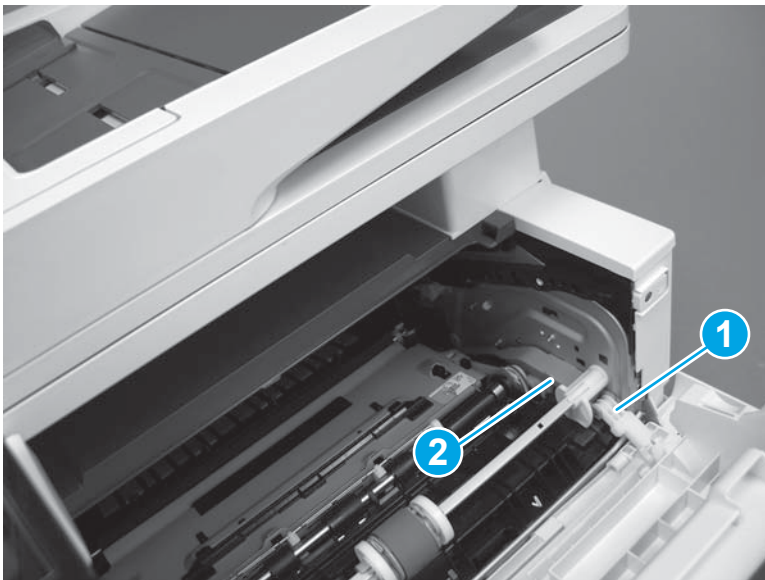

4. Slide the guide into the printer (callout 1), and then make sure that the tab (callout 2) snaps into place to secure the guide to the chassis.

Figure 1-1025 Install the guide

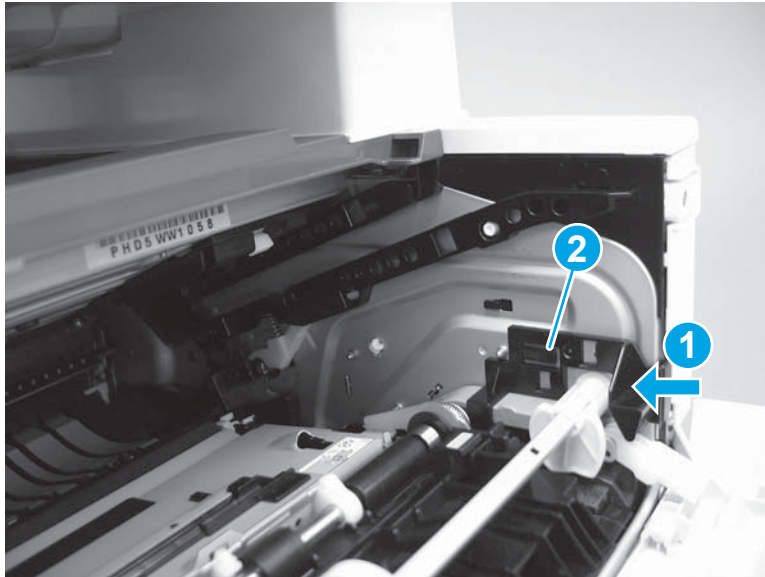

5. Position the shaft on the door, and then align the left-side hinge on the door with the hole in the chassis (callout 1).

Figure 1-1026 Align the hinge

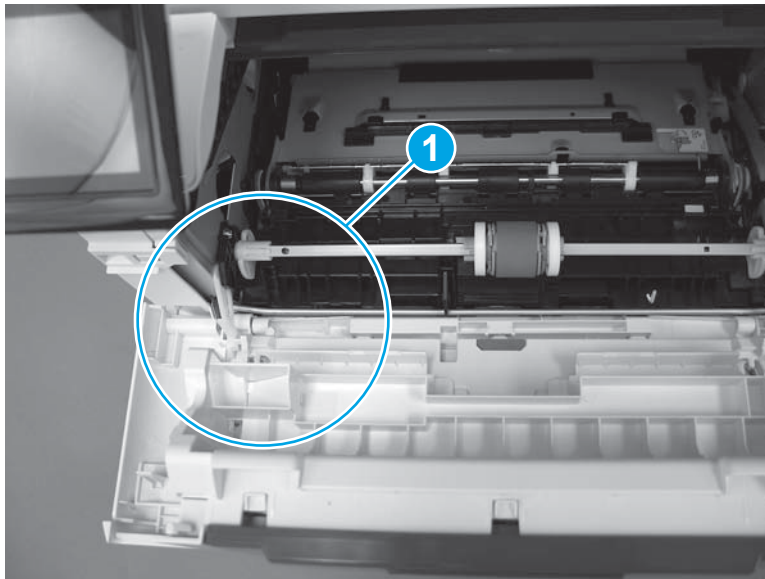

6. Push the shaft towards the left side of the printer to install it (callout 1).

 **Reinstallation tip:** Make sure that the support shaft is fully installed and correctly orientated (callout 2) so that it will not interfere with the door opening and closing.

Figure 1-1027 Install the support shaft



Step 21: Install Tray 2

- ▲ Slide the tray straight into the printer to install it.

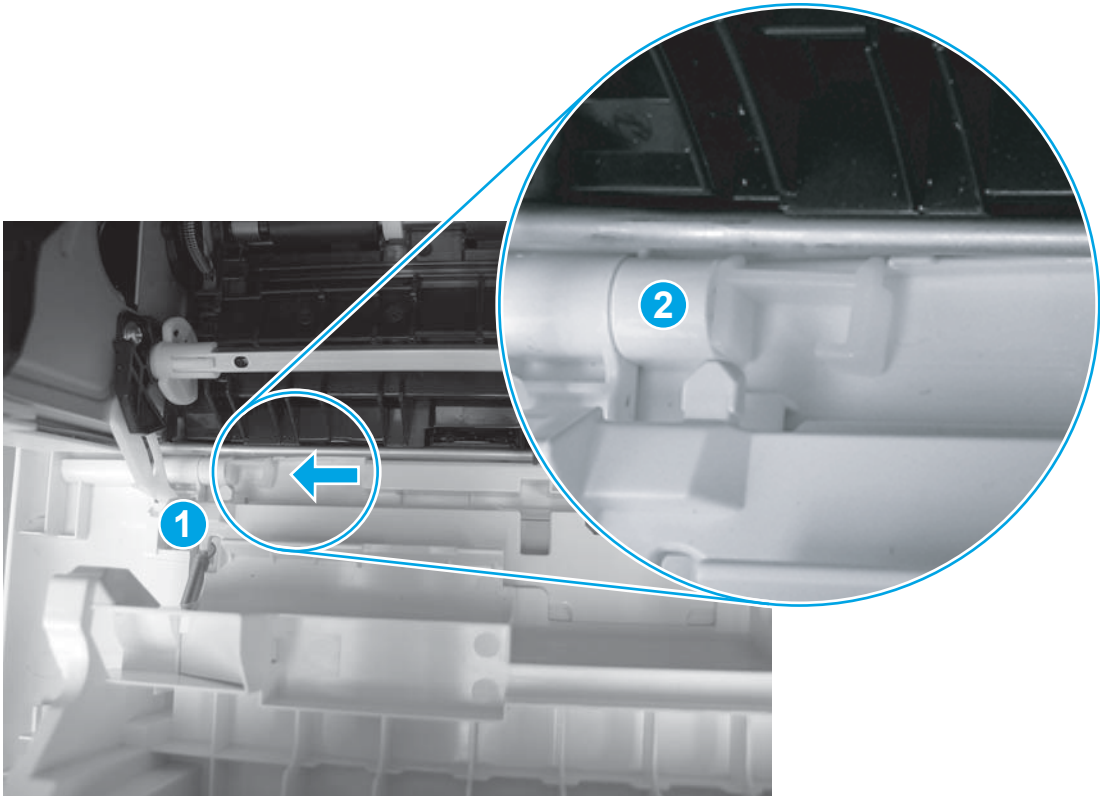
Figure 1-1028 Install the tray



Removal and replacement: Sheet-metal formatter bracket and formatter PCA

- [Step 1: Remove Tray 2](#)
- [Step 2: Remove the cartridge door assembly](#)
- [Step 3: Remove the left cover](#)
- [Step 4: Remove the right cover](#)
- [Step 5: Remove the integrated scanner assembly \(M427/M246\)](#)
- [Step 6: Remove the control panel \(M427/M246\)](#)
- [Step 7: Remove the top cover \(M427/M426\)](#)
- [Step 8: Remove the top cover \(M403/M402\)](#)
- [Step 9: Remove the sheet-metal formatter bracket and formatter PCA](#)
- [Step 10: Install the sheet-metal formatter bracket and formatter PCA](#)
- [Step 11: Install the top cover \(M403/M402\)](#)
- [Step 12: Install the top cover \(M427/M426\)](#)
- [Step 13: Install the control panel \(M427/M246\)](#)
- [Step 14: Install the integrated scanner assembly \(M427/M246\)](#)
- [Step 15: Install the right cover](#)
- [Step 16: Install the left cover](#)
- [Step 17: Install the cartridge door assembly](#)
- [Step 18: Install Tray 2](#)

Step 1: Remove Tray 2

- ▲ Pull the tray straight out of the printer to remove it.

Figure 1-1029 Remove the tray



Step 2: Remove the cartridge door assembly



NOTE: If the toner cartridge was not removed prior to servicing the printer, remove it now.

1. Release one tab (callout 1), and then slide shaft (callout 2) in the direction the arrow indicates and remove it.



TIP: It might be easier to release the support shaft by using a small flat-blade screwdriver.

Figure 1-1030 Release the support shaft

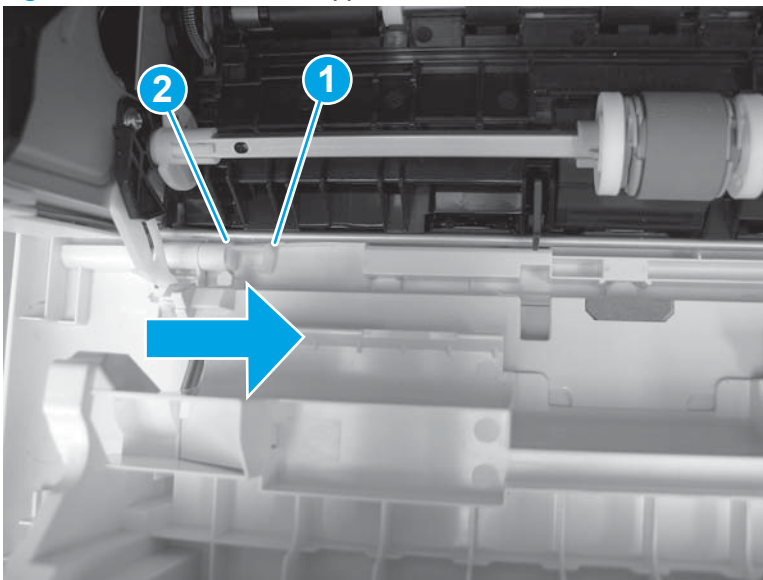

2. Release one tab (callout 1), and then slide the guide (callout 2) in the direction the arrow indicates and remove it.

Figure 1-1031 Remove the guide



3. Remove the link arm (callout 1).

Figure 1-1032 Remove the link arm

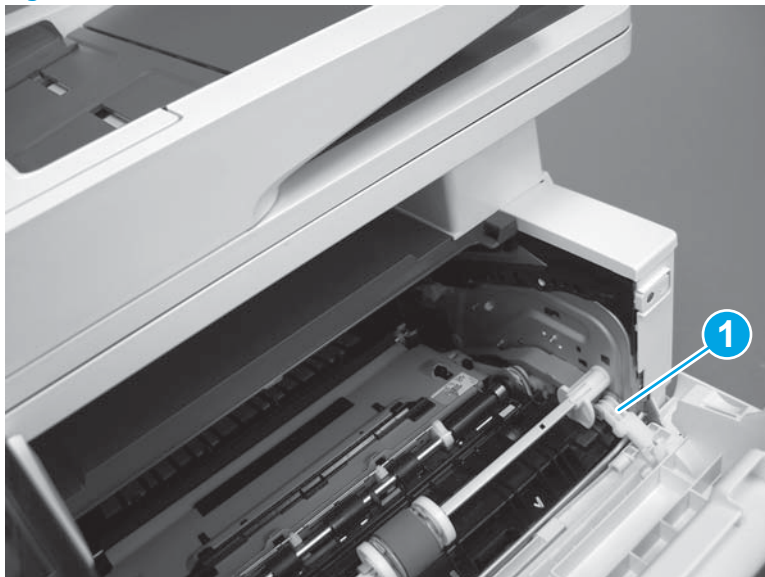

4. Slide the cartridge door assembly (callout 1) in the direction the arrow indicates and remove it.

Figure 1-1033 Remove the door

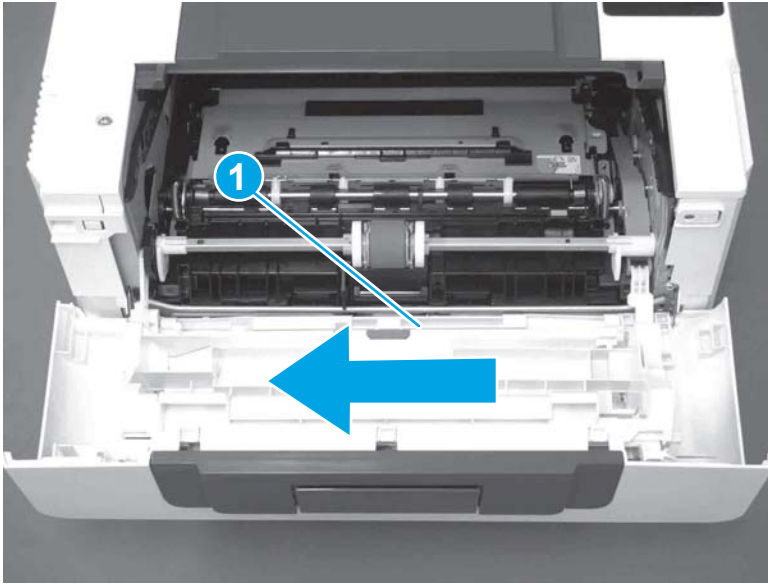

5. Remove the link (callout 1) from the cartridge door assembly (callout 2).

Figure 1-1034 Release the left-side retainer arm

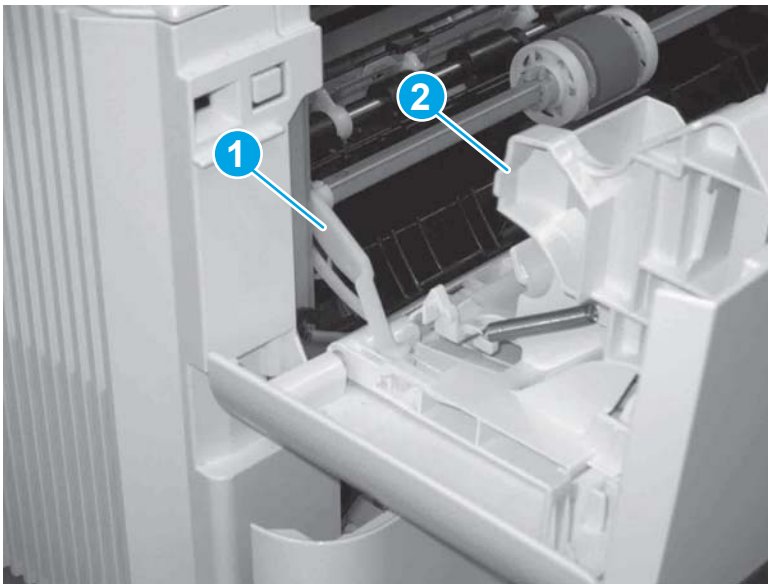

Step 3: Remove the left cover

1. Remove one screw (callout 1).

Figure 1-1035 Remove one screw

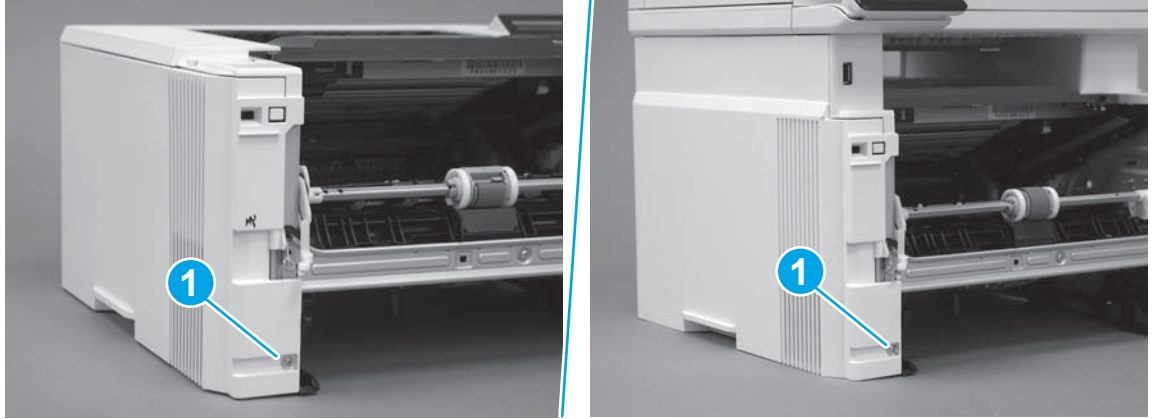

2. Open the rear door, release two bosses (callout 1), and then release three tabs (callout 2).

Figure 1-1036 Release two bosses and three tabs

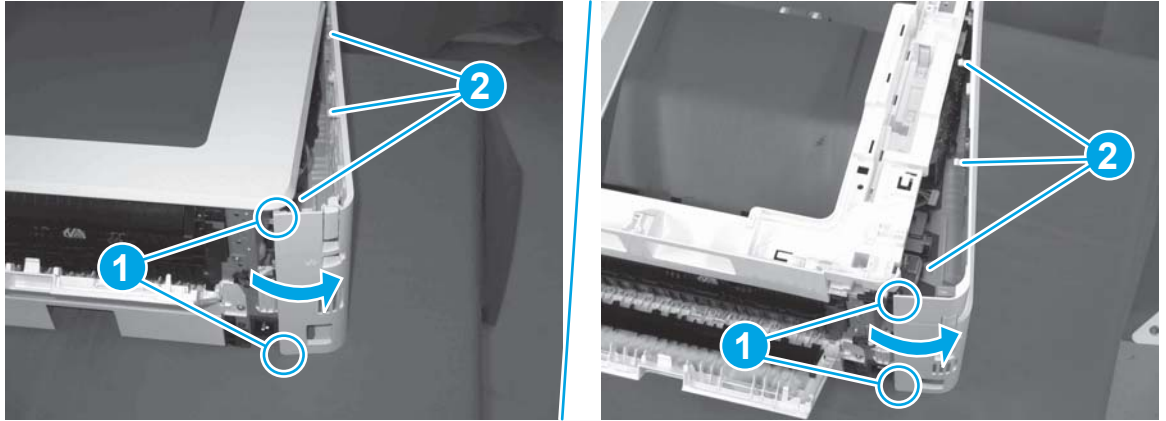

3. At the front of the printer, do one of the following:

- **M403/M402:** Release two bosses (callout 1), and then remove the cover (callout 2).
- **M427/M426:** Release one tab (callout 3), two bosses (callout 4), and then remove the cover (callout 5).

CAUTION: Be careful when releasing the upper bosses on the M427/M426 cover. One portion of the cover (callout 6) is fragile and is easily broken.

Figure 1-1037 Remove the cover

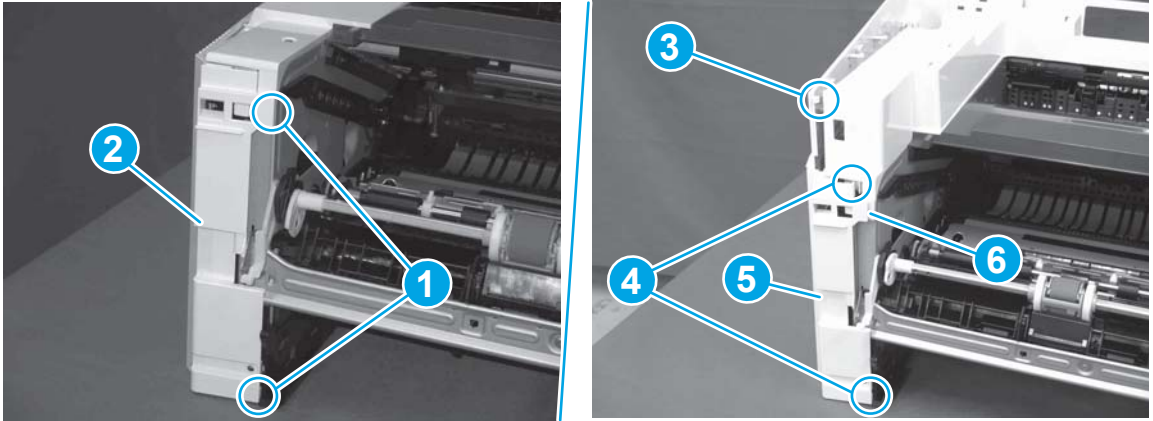

Step 4: Remove the right cover

1. Remove one screw (callout 1).

Figure 1-1038 Remove one screw



2. At the front of the printer, release two bosses (callout 1), and then release three tabs (callout 2).

Figure 1-1039 Release two bosses and three tabs

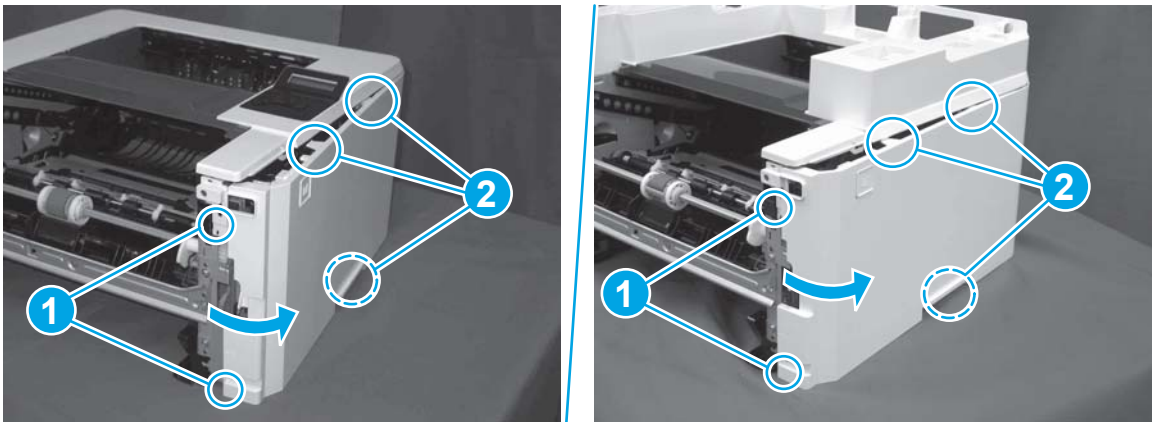

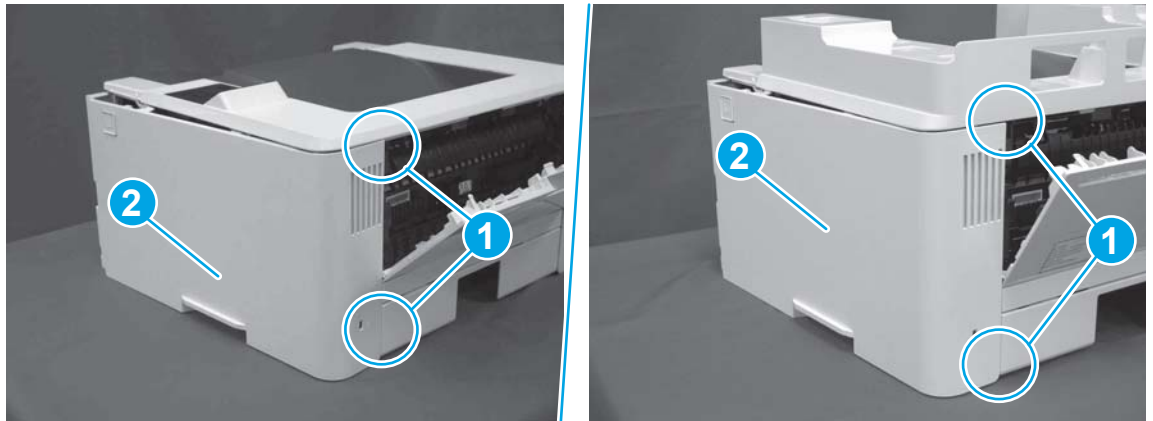

3. Open the rear door, release two bosses (callout 1), and then remove the cover (callout 2).

Figure 1-1040 Remove the cover



Step 5: Remove the integrated scanner assembly (M427/M246)

 **NOTE:** The step is for the M427/M426 printer. For the M403/M402, skip this step and go to [Step 8: Remove the top cover \(M403/M402\) on page 583](#).

 **NOTE:** M427/M426 models only. The integrated scanner assembly (ISA) includes the sub-scanner assembly (SSA) and the automatic document feeder (ADF).

1. Raise the ISA.

Figure 1-1041 Raise the ISA

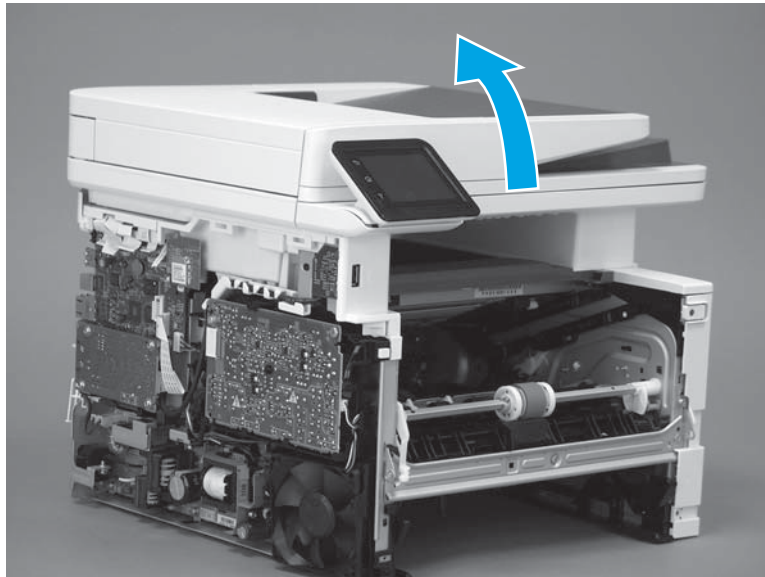

2. Release the ISA flat-flexible cable (FFC) cover (callout 1), and then remove it (callout 2).

Figure 1-1042 Remove the ISA FFC cover

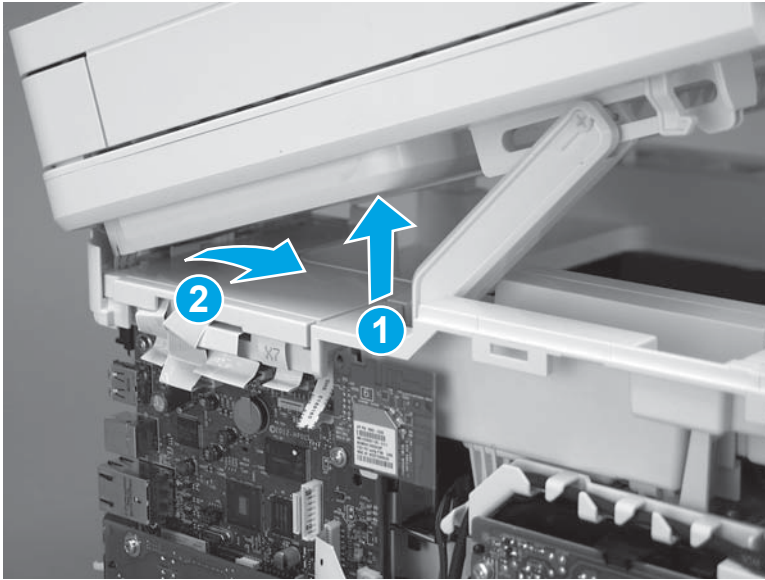

3. Disconnect three FFCs (callout 1), and then remove the ferrite (callout 2) from the holder.

CAUTION: The ferrite is not captive on the FFC. Do not lose the ferrite while handling the ISA.

Figure 1-1043 Disconnect three FFCs

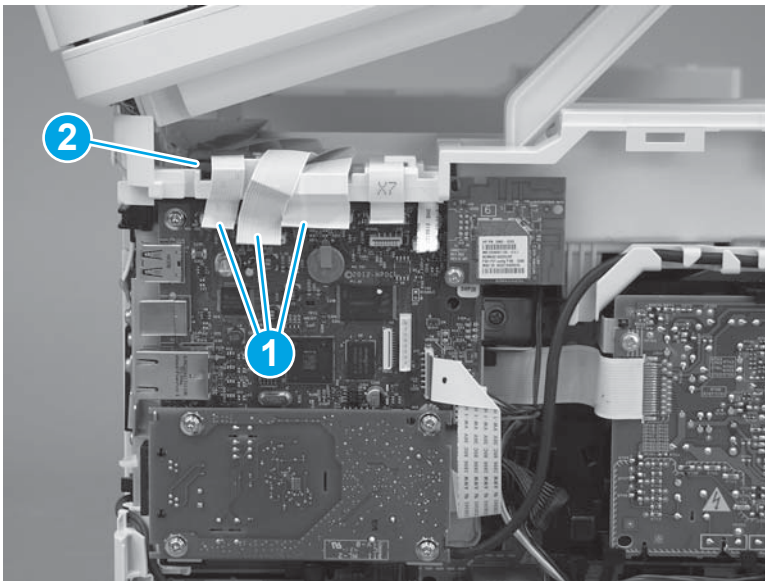

4. Remove one screw (callout 1).

Figure 1-1044 Remove one screw

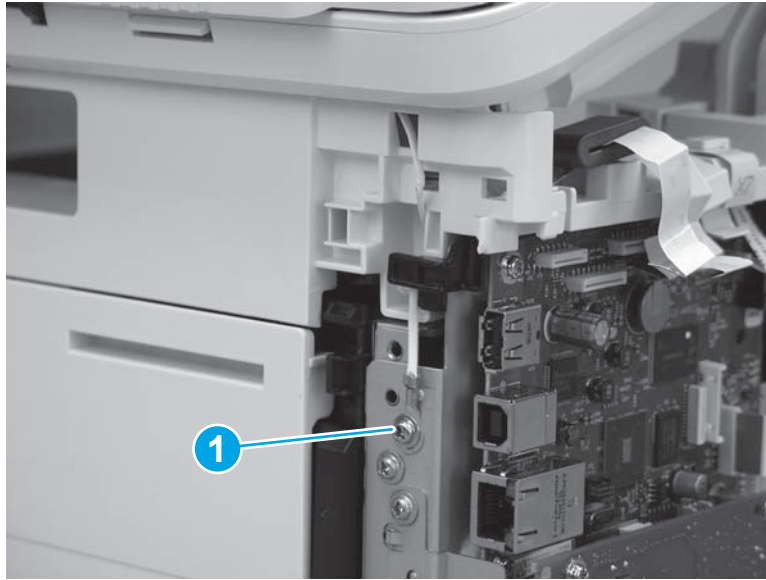

5. Pass the ground wire through the opening in the top cover.

Figure 1-1045 Pass the wire through the opening

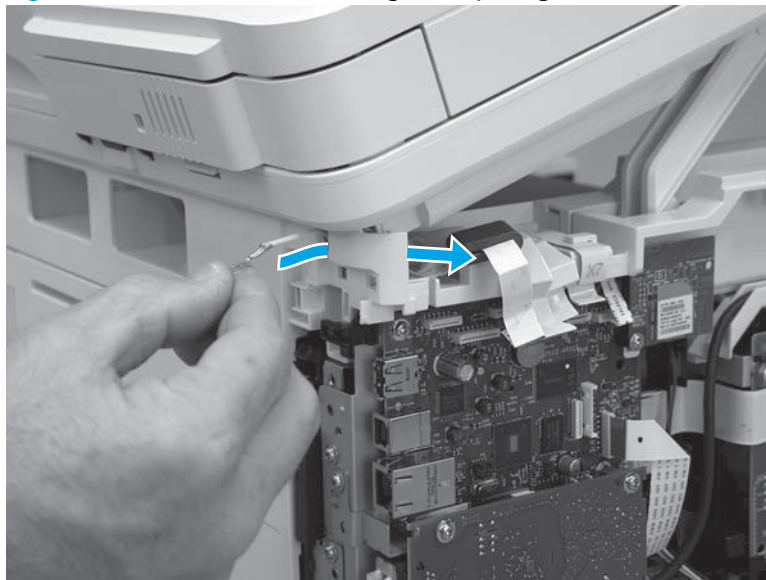

6. Release one tab (callout 1), and then rotate the ISA slider pin (callout 2) towards the front of the printer to release it.

Figure 1-1046 Release one tab and rotate the slider pin

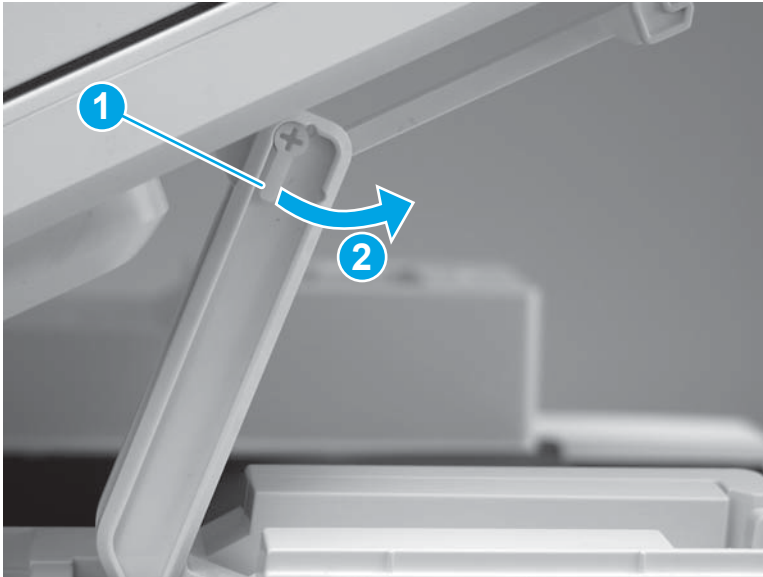

7. Remove the slider pin.

Figure 1-1047 Remove the slider pin

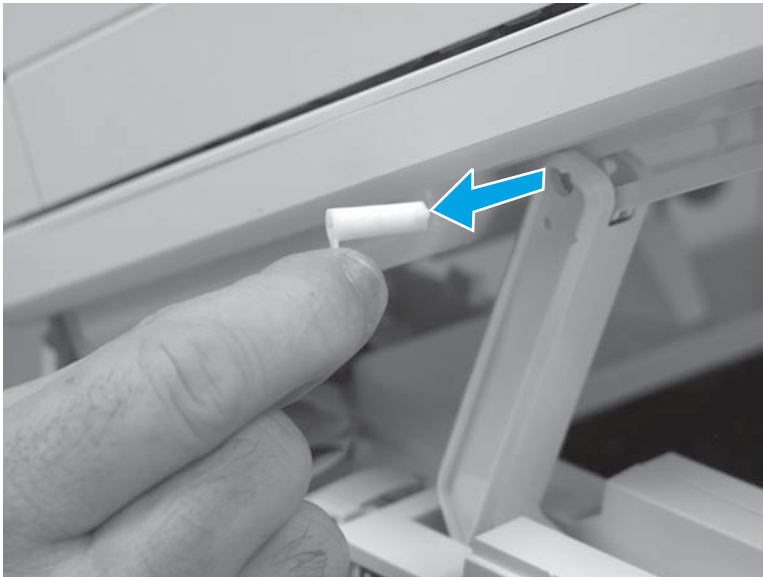

8. Rotate the ISA towards the rear of the printer until it stops.

Figure 1-1048 Rotate the ISA towards the rear of the printer



9. Slide the ISA as shown to release it.

Figure 1-1049 Release the ISA

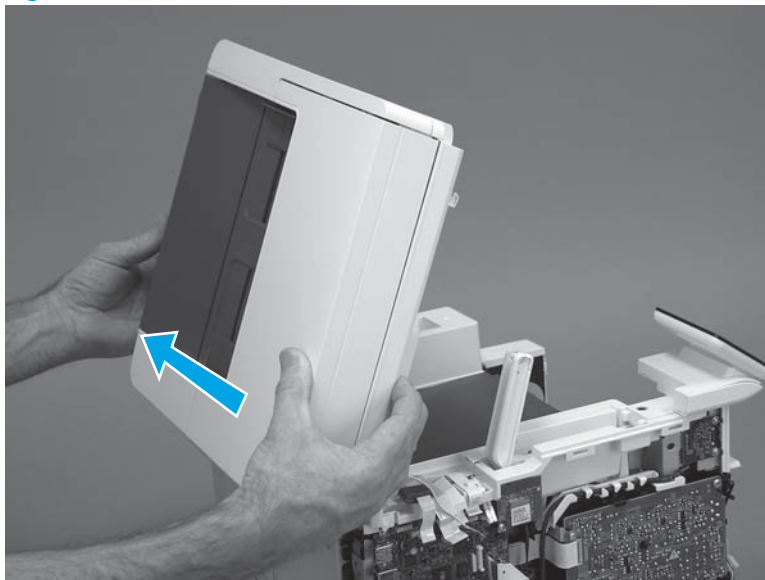

10. Remove the ISA.

Figure 1-1050 Remove the ISA

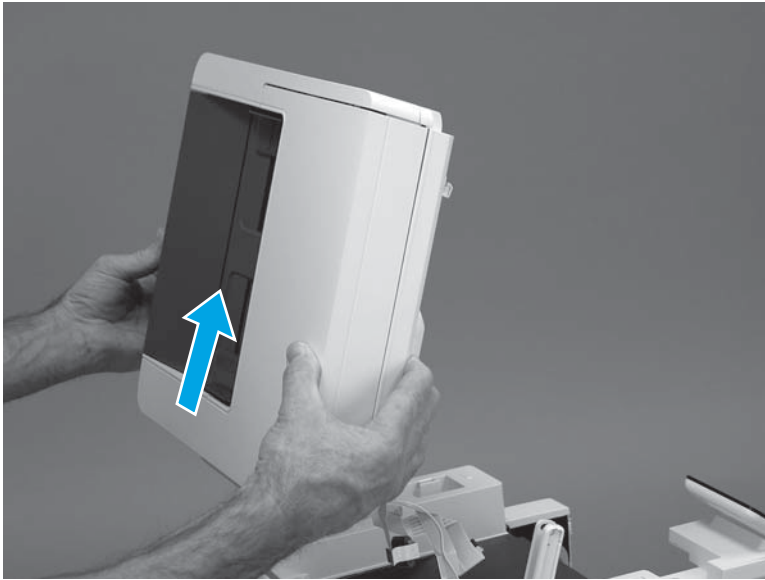

Step 6: Remove the control panel (M427/M246)



NOTE: The step is for the M427/M426 printer. For the M403/M402, skip this step and go to [Step 8: Remove the top cover \(M403/M402\) on page 583](#).

1. Disconnect one FFC (callout 1; J114), and then release the FFC from the retainer (callout 2).

Figure 1-1051 Disconnect one connector

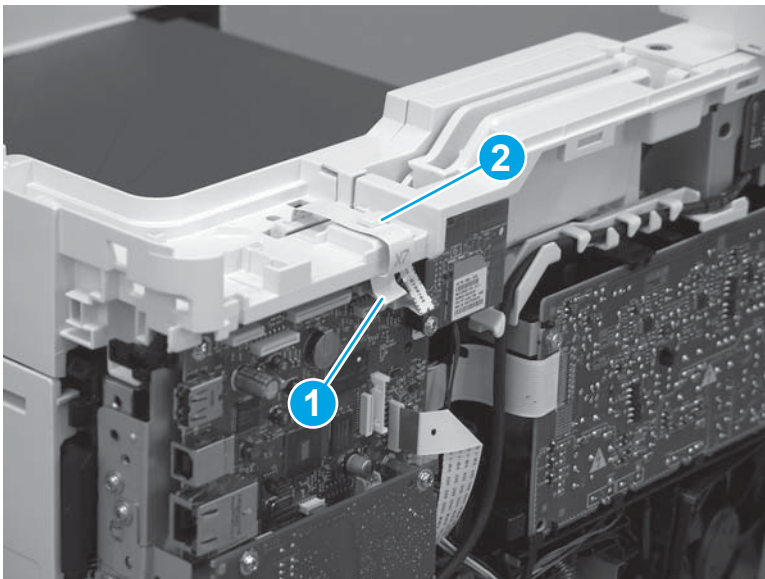

2. Remove one screw (callout 1).

Figure 1-1052 Remove one screw

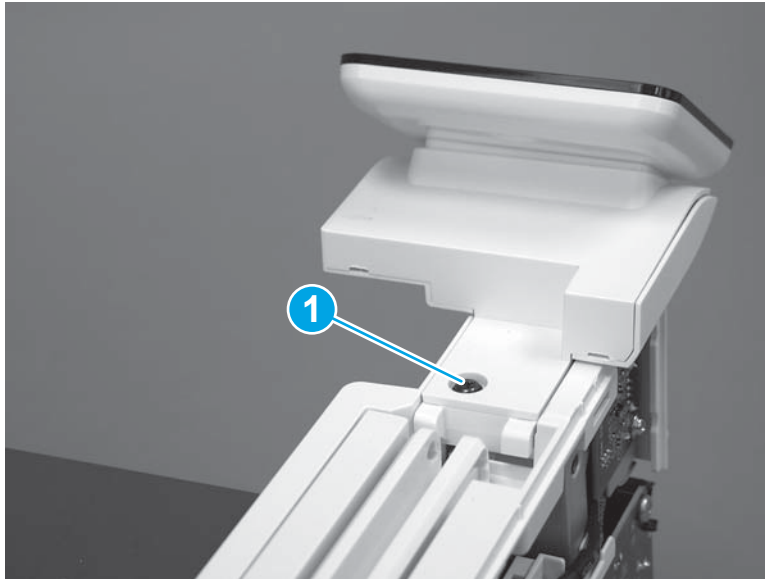

3. Use a small flat-blade screwdriver to release two tabs (callout 1) on the control-panel cable cover.

Figure 1-1053 Release two tabs

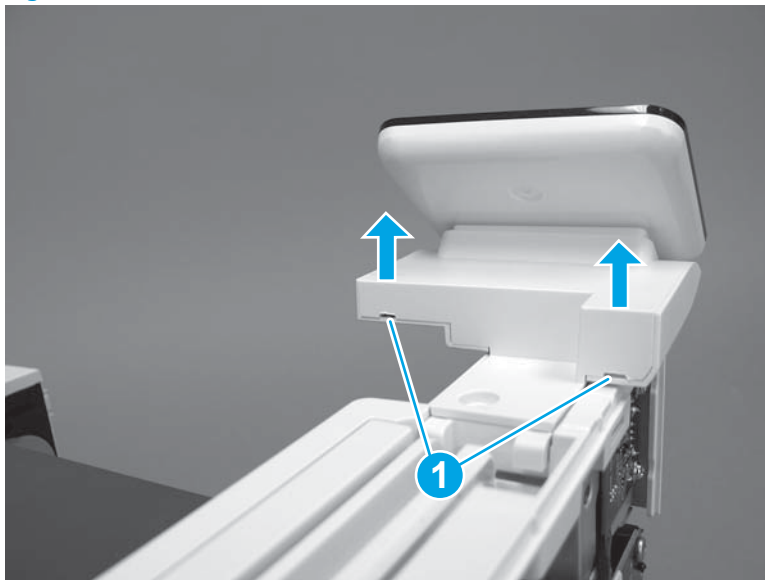

4. Remove the control-panel cable cover.

Figure 1-1054 Remove the cover

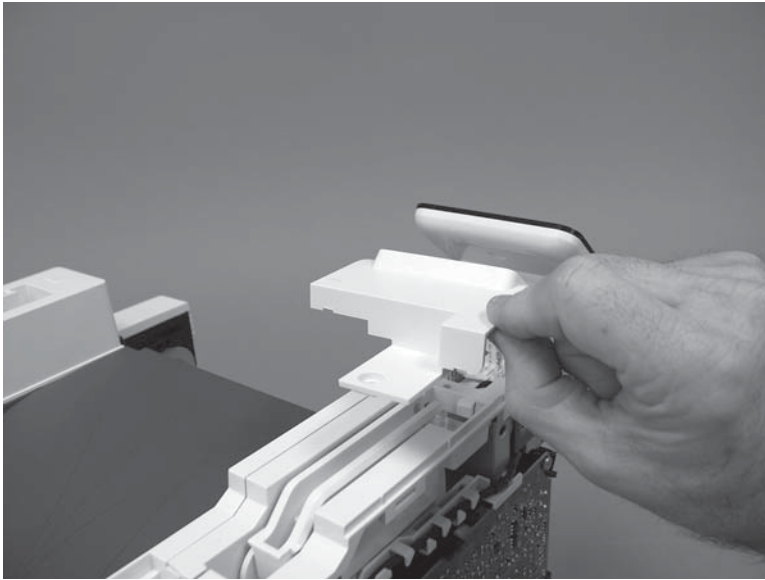

5. Remove one grounding screw (callout 1), and then move the ground cable (callout 2) out of the way.

Figure 1-1055 Remove one screw

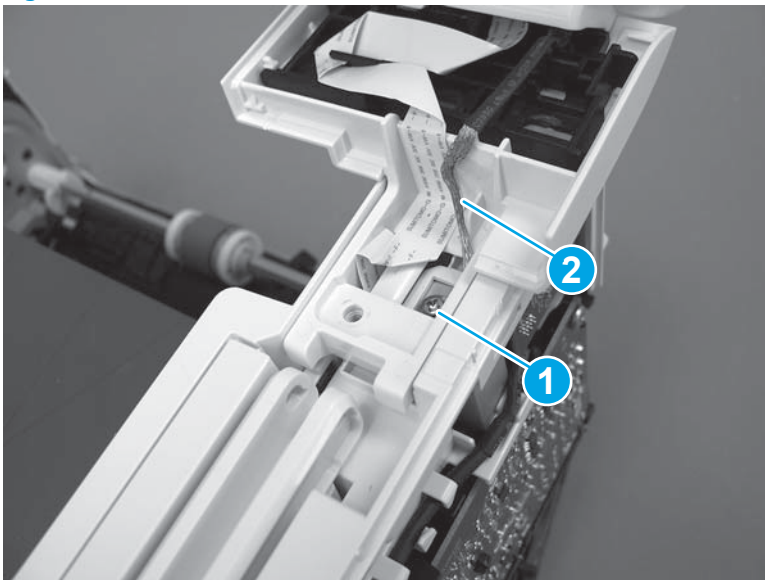

6. Move the FFC out of the way, and then remove two screws (callout 1).

Figure 1-1056 Remove two screws

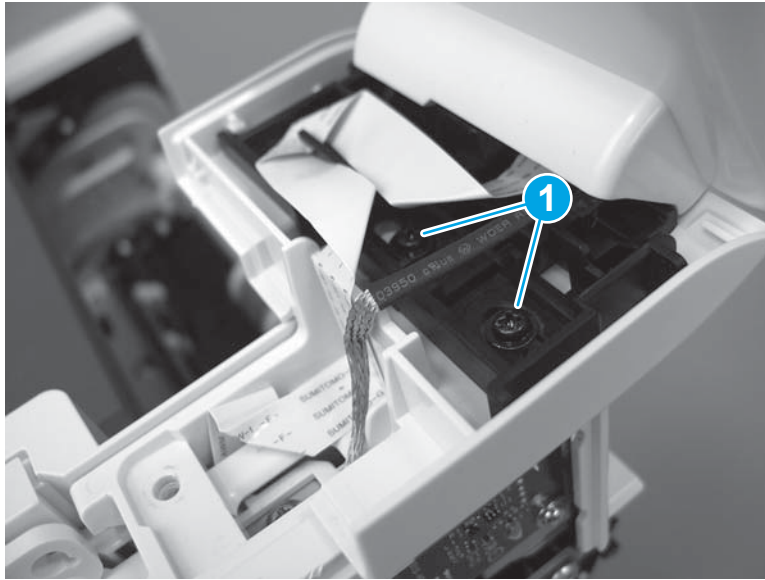

7. Slightly lift up the control-panel assembly to separate it from the top cover.

⚠ CAUTION: The control panel assembly is still connected to the printer by the FFC. Do not attempt to completely remove the assembly.

Figure 1-1057 Lift up the control-panel assembly

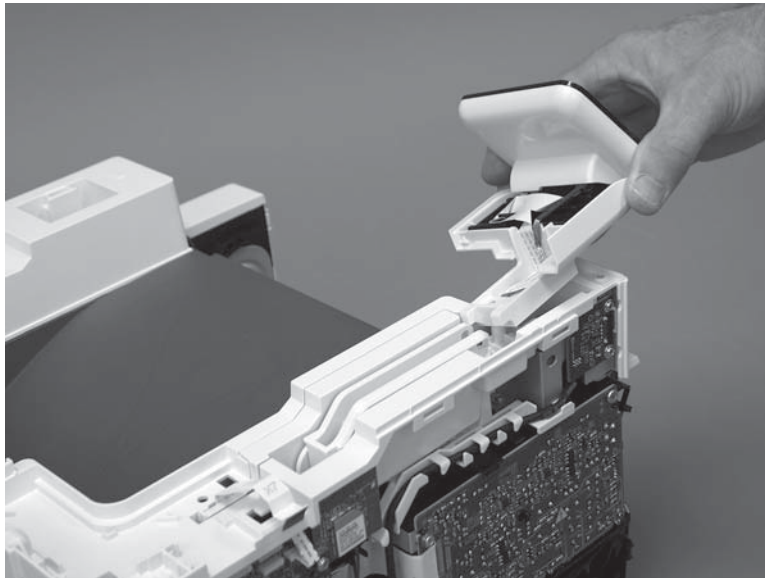

8. Lift up the control-panel FFC cover to remove the control-panel assembly.

Figure 1-1058 Remove the control-panel assembly

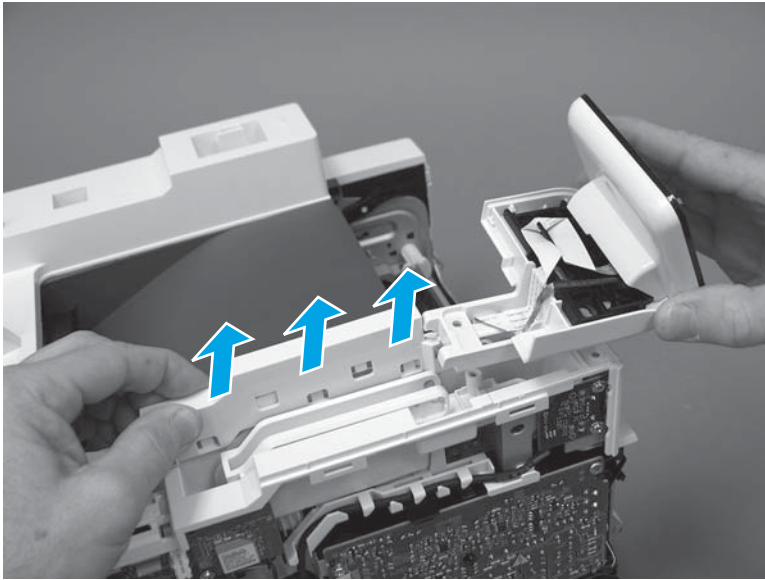

Step 7: Remove the top cover (M427/M426)



NOTE: The step is for the M427/M426 printer. For the M403/M402, skip this step and go to [Step 8: Remove the top cover \(M403/M402\) on page 583](#).

1. Release the USB cable (callout 1) from the cable guide.

Figure 1-1059 Remove the USB cable

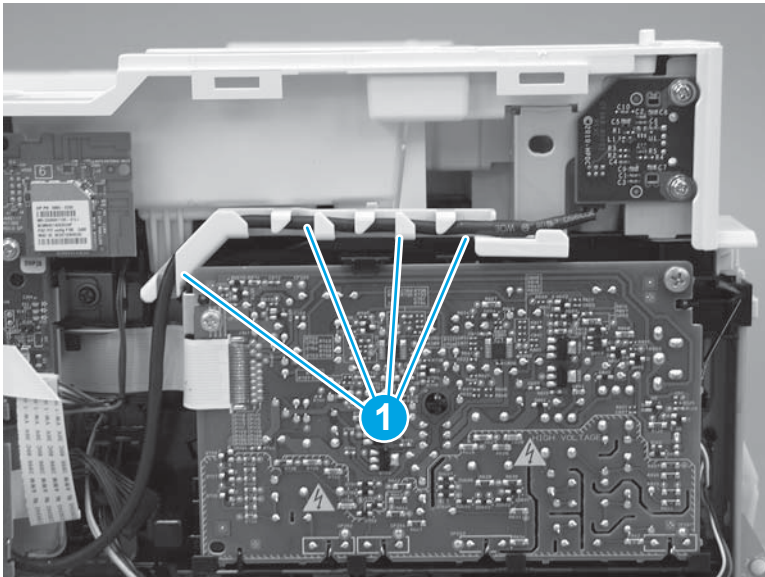

2. Remove five screws (callout 1), release four bosses (callout 2), and then remove the top cover (callout 3).

Figure 1-1060 Remove the cover

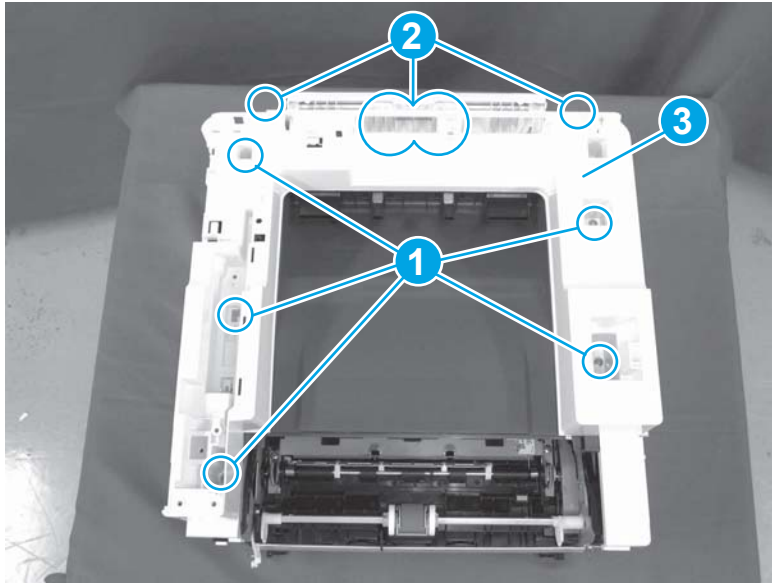

Step 8: Remove the top cover (M403/M402)

 **NOTE:** The step is for the M403/M402 printer. For the M427/M426, skip this step and go to [Step 9: Remove the sheet-metal formatter bracket and formatter PCA on page 584.](#)

1. Remove one screw (callout 1).

Figure 1-1061 Remove one screw



2. At the right side of the printer, release the one boss (callout 1), and then release one tab (callout 2).

Figure 1-1062 Release one boss and one tab

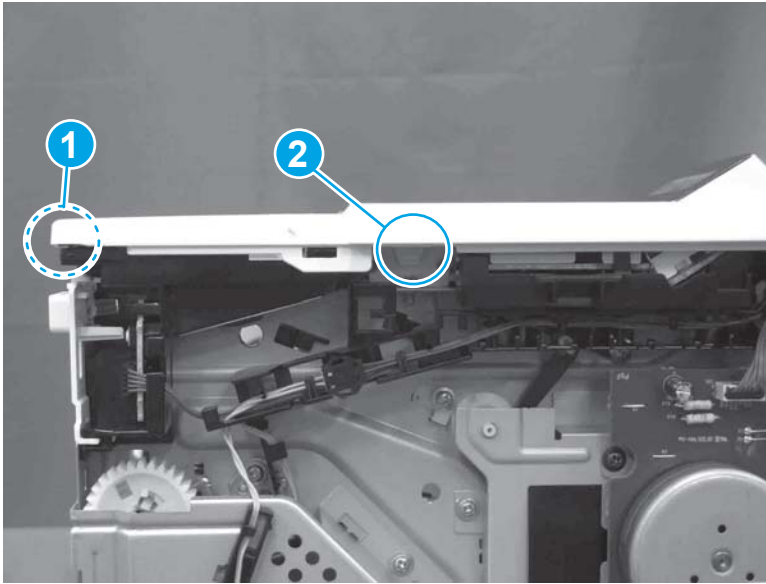

3. Release four tabs (callout 1), release four bosses (callout 2), and then remove the top cover (callout 3).

 **TIP:** Open the rear door to make releasing the bosses (callout 3) easier.

Figure 1-1063 Remove the cover



Step 9: Remove the sheet-metal formatter bracket and formatter PCA

 **NOTE:** Disconnect any remaining formatter PCA FFCs or wire-harness connectors.

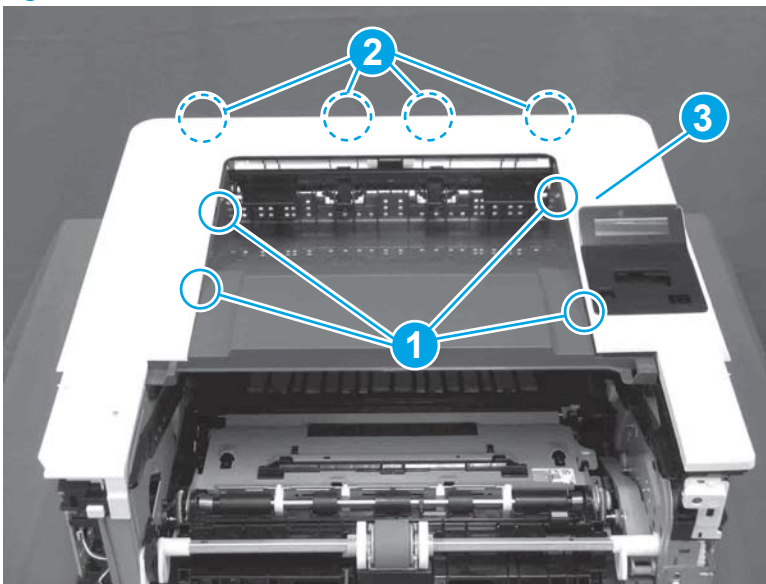
1. **M427/M426 only:** Remove the guide (callout 1).

Figure 1-1064 Remove the guide

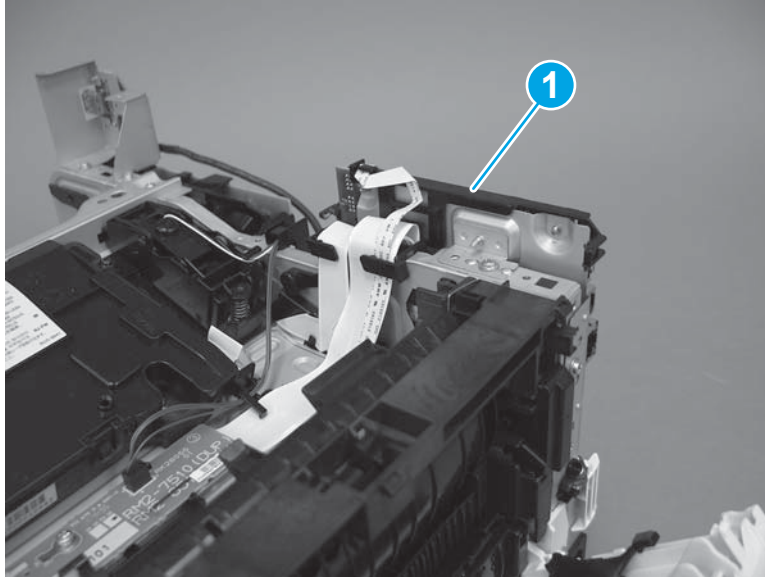

2. Remove two screws (callout 1).

Figure 1-1065 Remove two screws

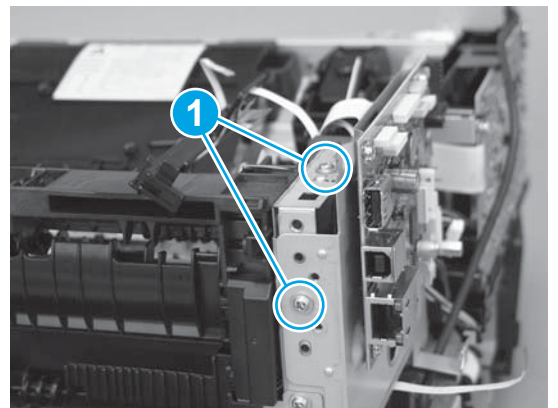
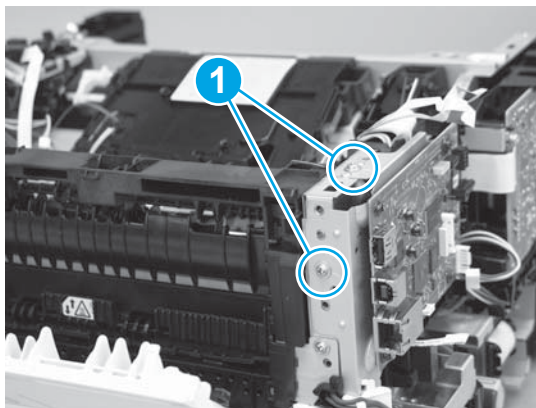

3. Disconnect one connector (callout 1), and then release the wire harness from the guide (callout 2).

Figure 1-1066 Disconnect one connector

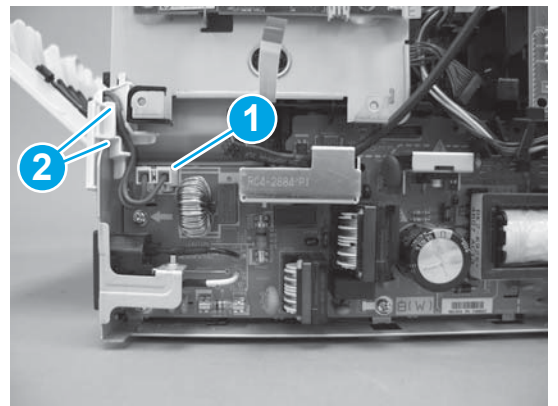
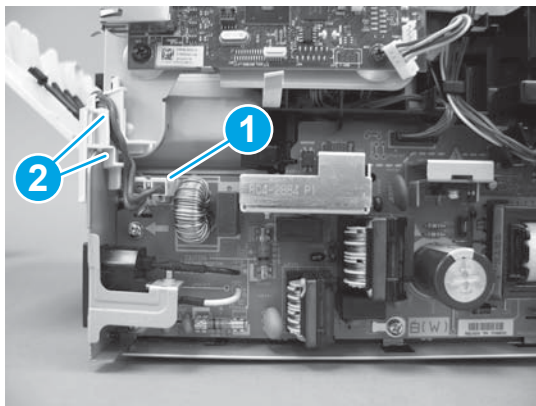

4. Remove the guide (callout 1).

Figure 1-1067 Remove the guide

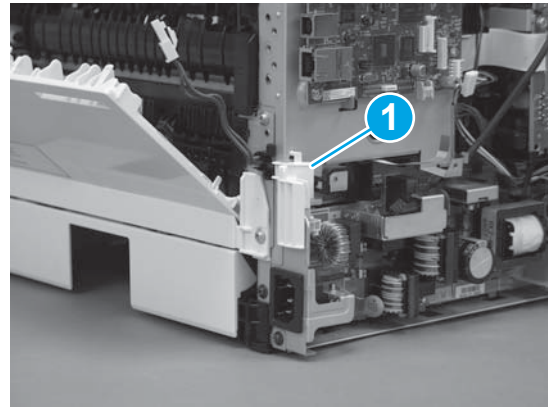
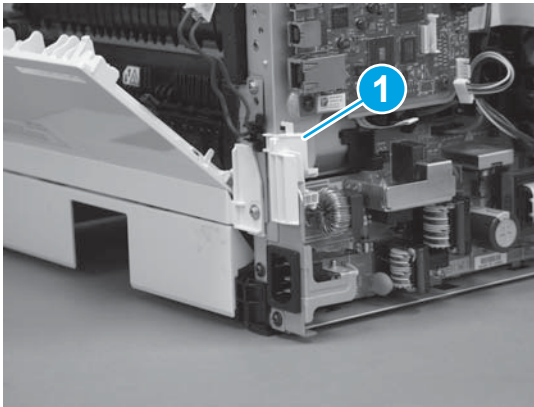

5. Remove three screws (callout 1).

Figure 1-1068 Remove three screws

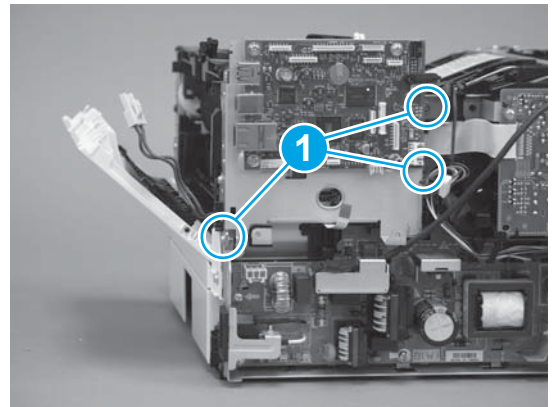
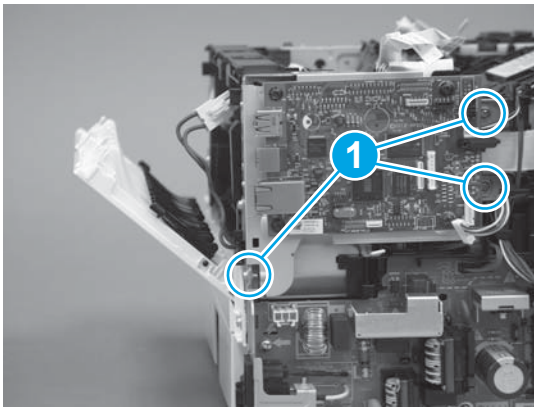

6. Remove the sheet-metal bracket and formatter PCA.

Figure 1-1069 Remove the bracket

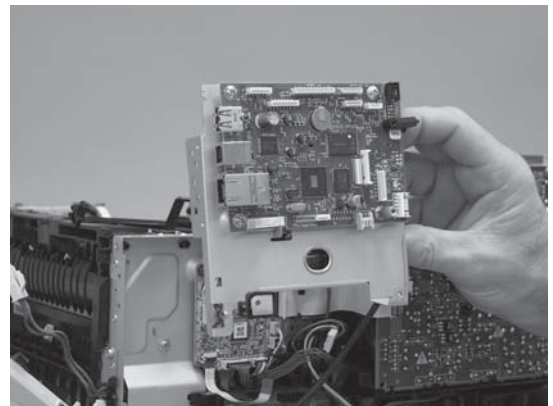
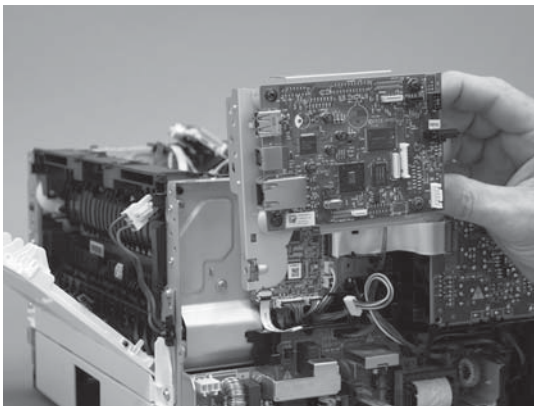

Step 10: Install the sheet-metal formatter bracket and formatter PCA

 **NOTE:** Do not forget to connect any formatter PCA FFCs or wire-harness connectors that were disconnected when the bracket was removed.

1. Position the sheet-metal bracket and formatter PCA on the printer.

Figure 1-1070 Install the bracket

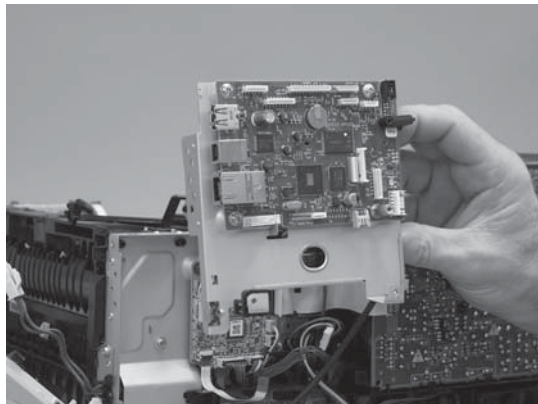
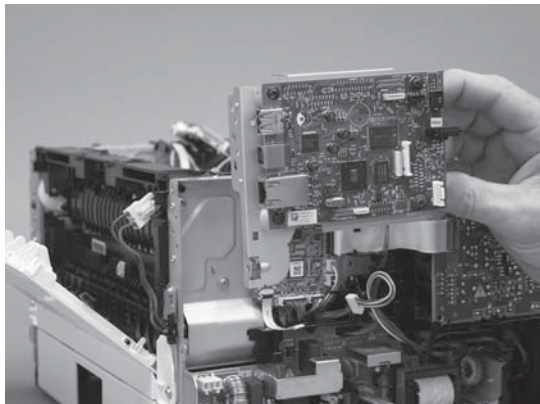

2. Install three screws (callout 1).

Figure 1-1071 Install three screws

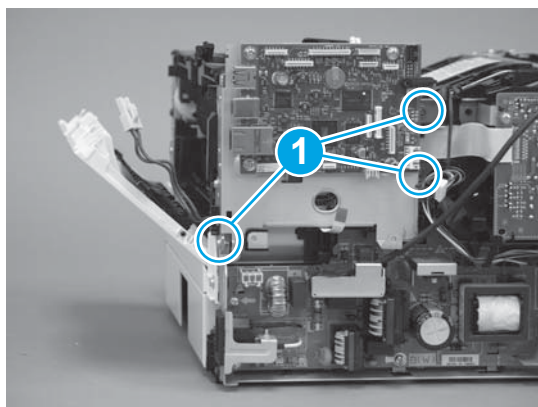
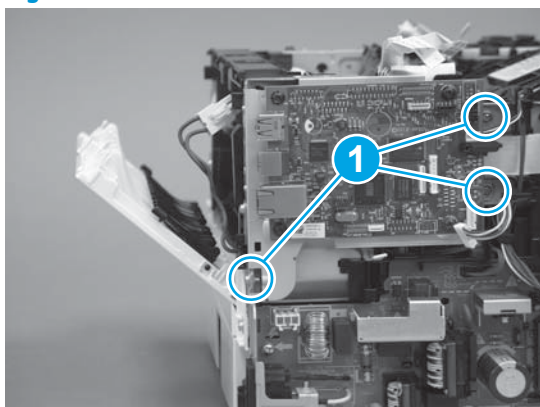

3. Install the guide (callout 1).

Figure 1-1072 Install the guide

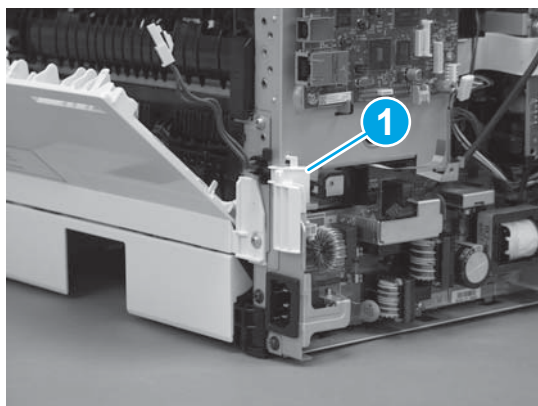
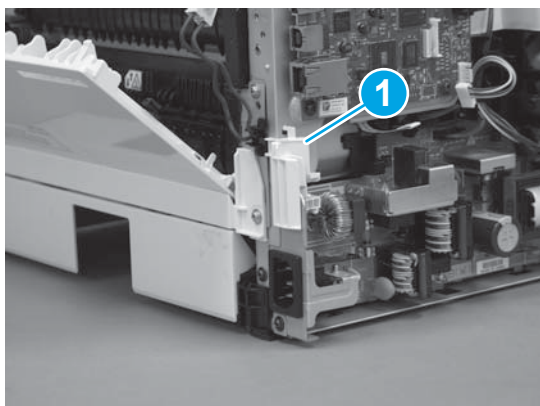

4. Connect one connector (callout 1), and then install the wire harness in the guide (callout 2).

Figure 1-1073 Connect one connector

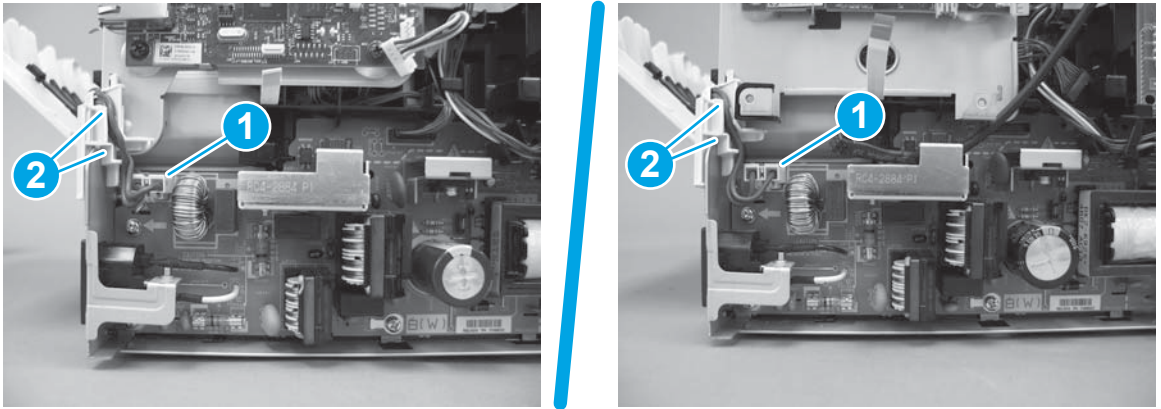

5. Install two screws (callout 1).

Figure 1-1074 Install two screws

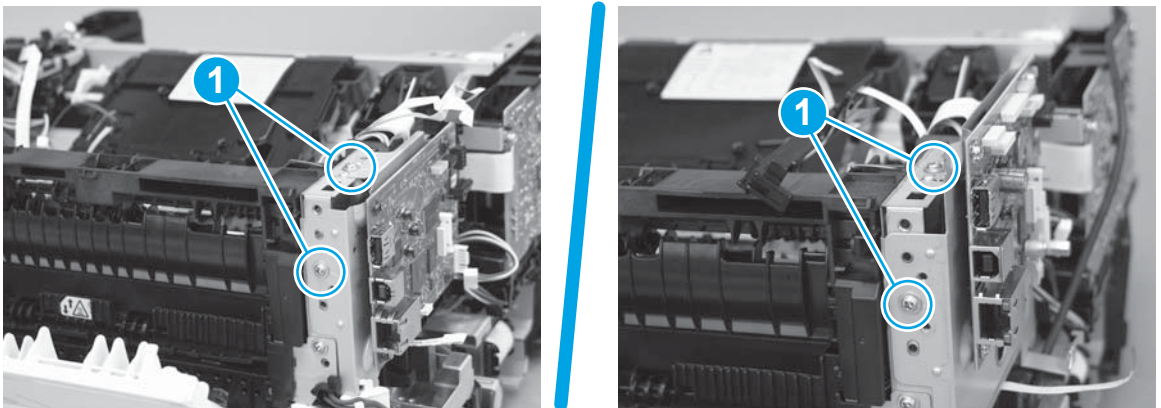

6. **M427/M426 only:** Install the guide (callout 1).

Figure 1-1075 Install the guide

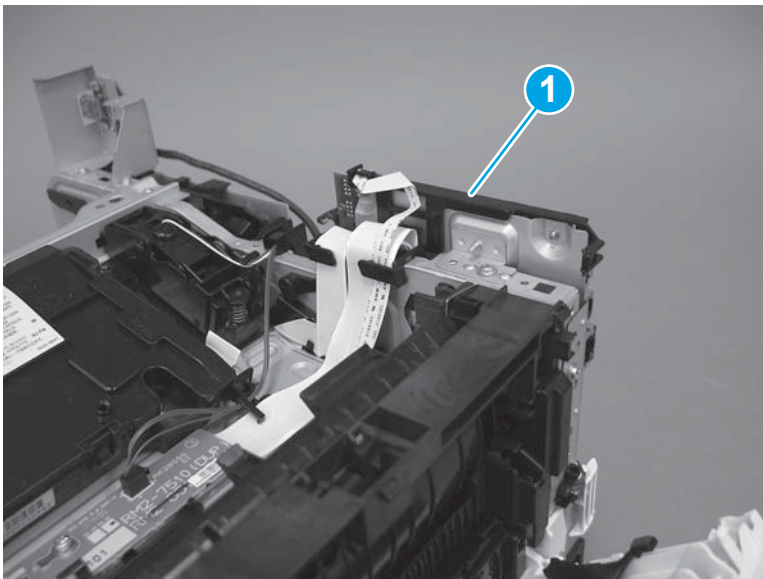

Step 11: Install the top cover (M403/M402)

 **NOTE:** The step is for the M403/M402 printer. For the M427/M426, skip this step and go to [Step 12: Install the top cover \(M427/M426\) on page 590](#).

1. Position the rear edge of the cover on the printer.

Figure 1-1076 Install the cover

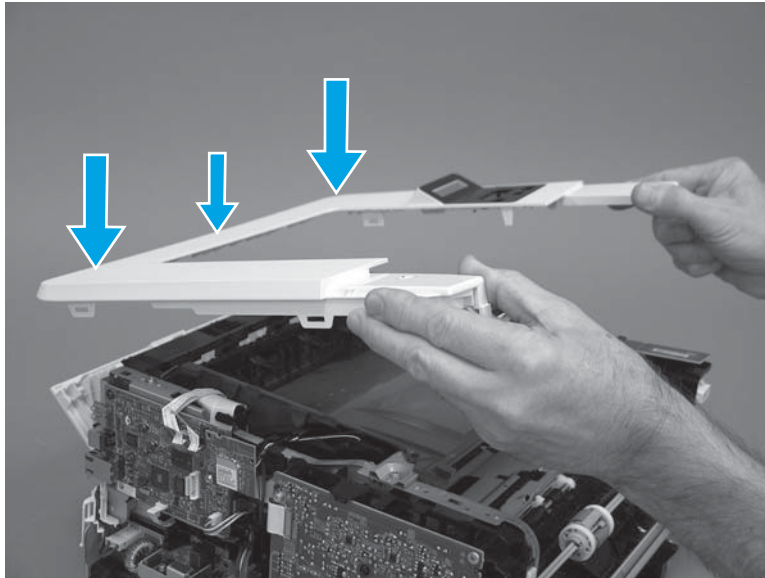

2. Engage four bosses (callout 1), rotate the front of the cover down (callout 2) and onto from the printer, and then engage four tabs (callout 3).

Figure 1-1077 Engage four bosses and tabs

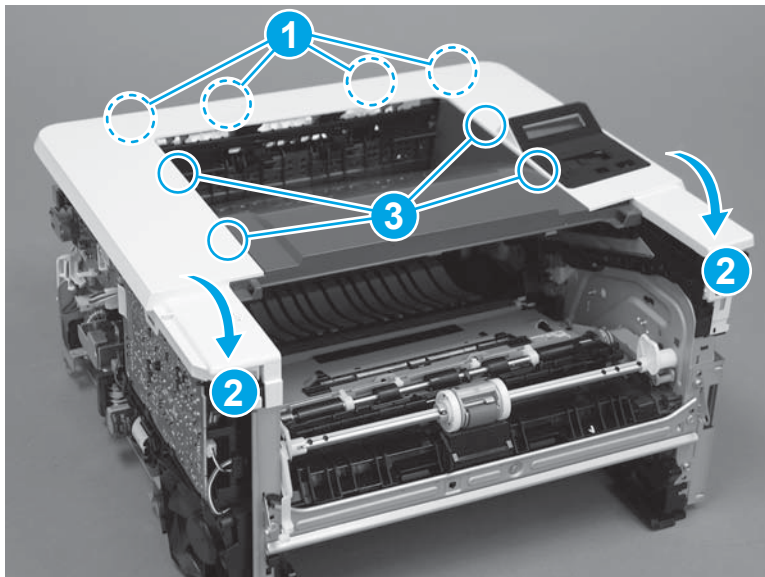

3. At the right side of the printer, engage the one boss and one tab (callout 1).

Figure 1-1078 Engage one boss and one tab

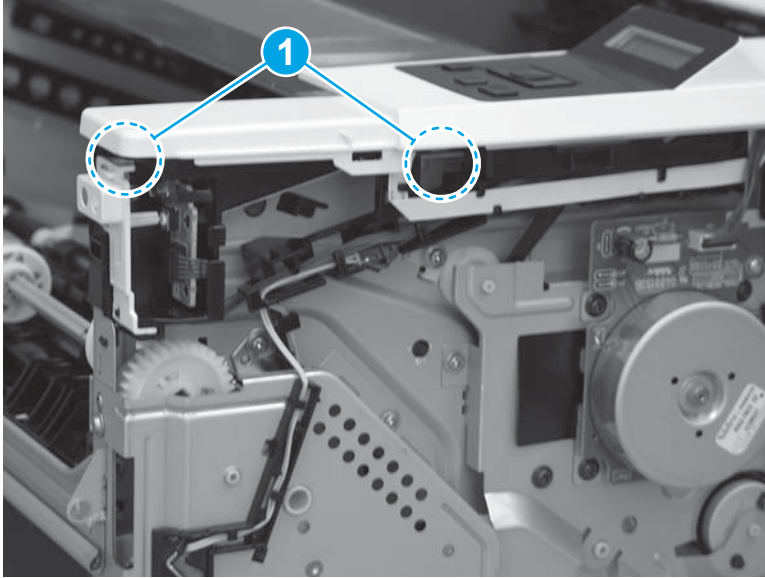

4. Install one screw (callout 1).

Figure 1-1079 Install one screw

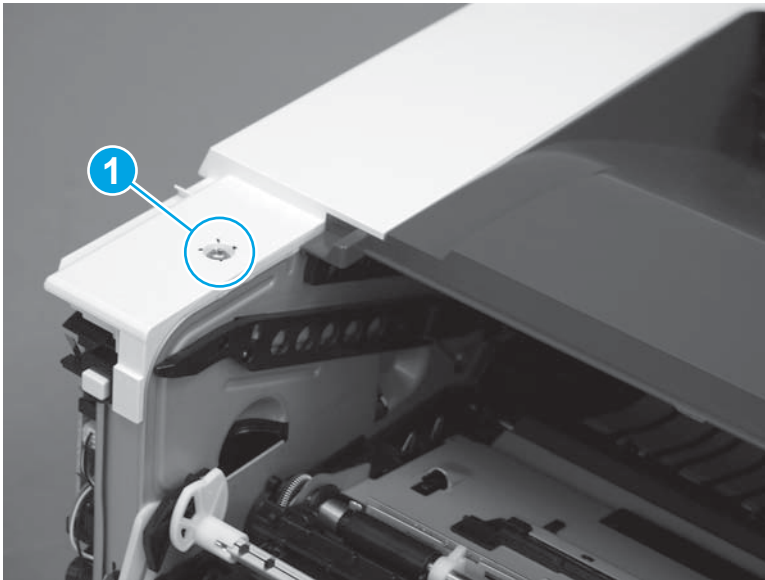

Step 12: Install the top cover (M427/M426)

 **NOTE:** The step is for the M427/M426 printer. For the M403/M402, skip this step and go to [Step 15: Install the right cover on page 602](#).

1. Position the rear edge of the top cover on the printer.

Figure 1-1080 Install the cover

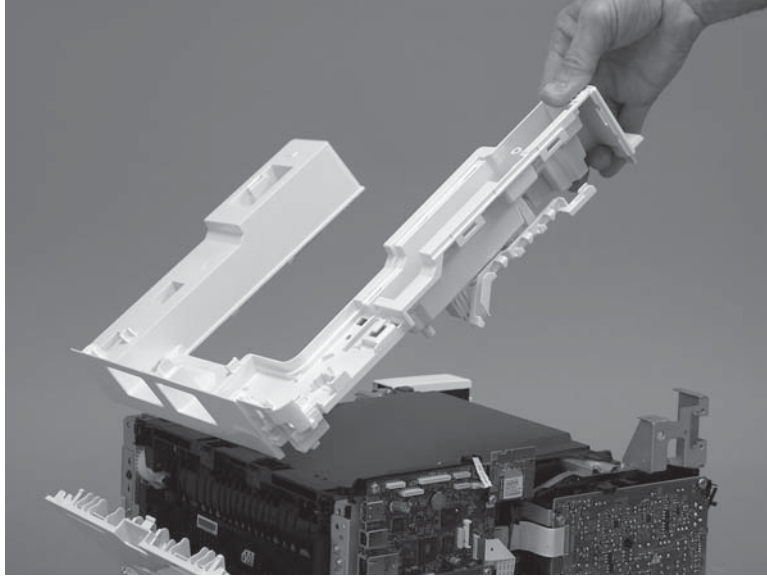

2. Engage four bosses (callout 1).

Figure 1-1081 Engage four bosses

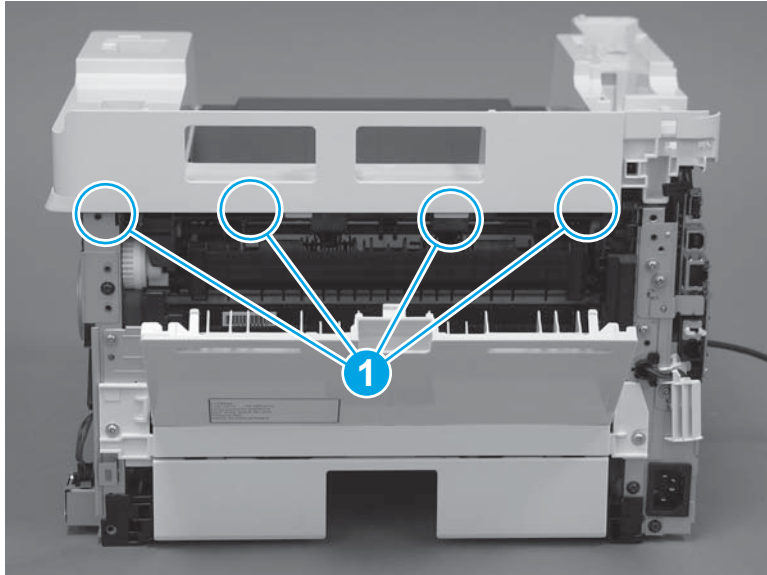

3. Rotate the front edge of the cover down.

Figure 1-1082 Rotate the front edge of the cover down

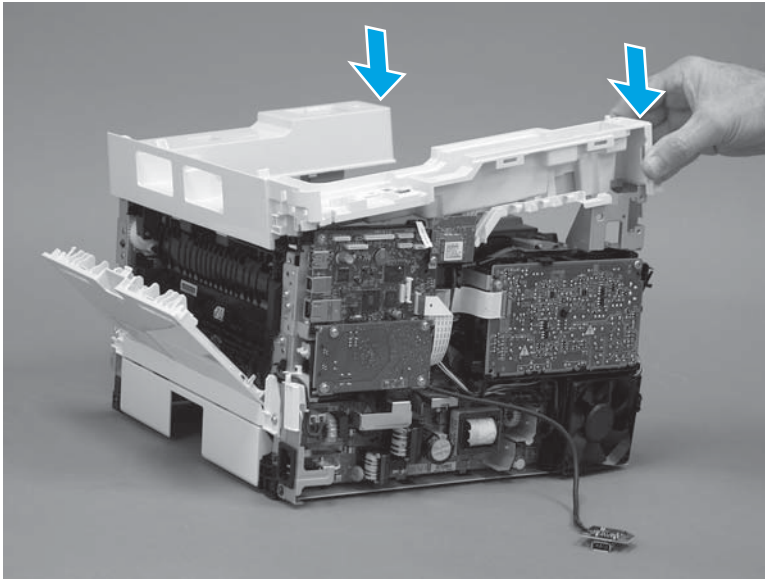

4. Install the USB cable (callout 1) in the guide.

Figure 1-1083 Install the USB PCA

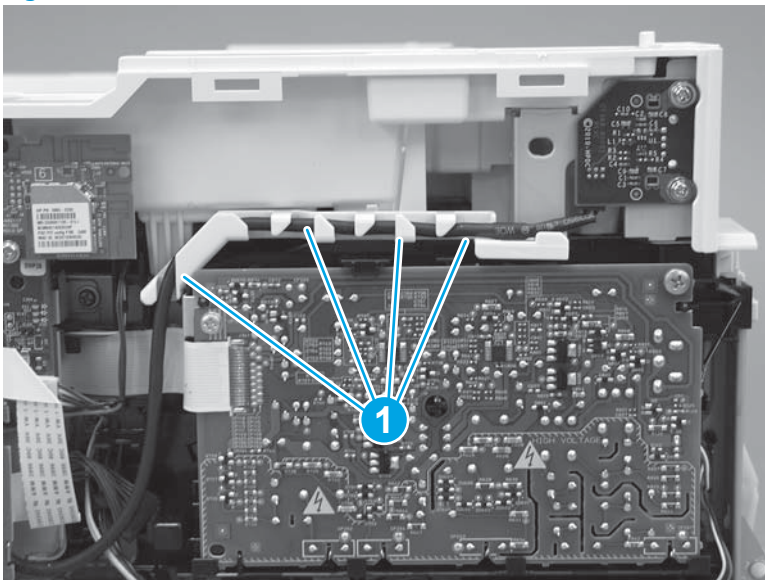

5. Install five screws (callout 1).

Figure 1-1084 Install five screws

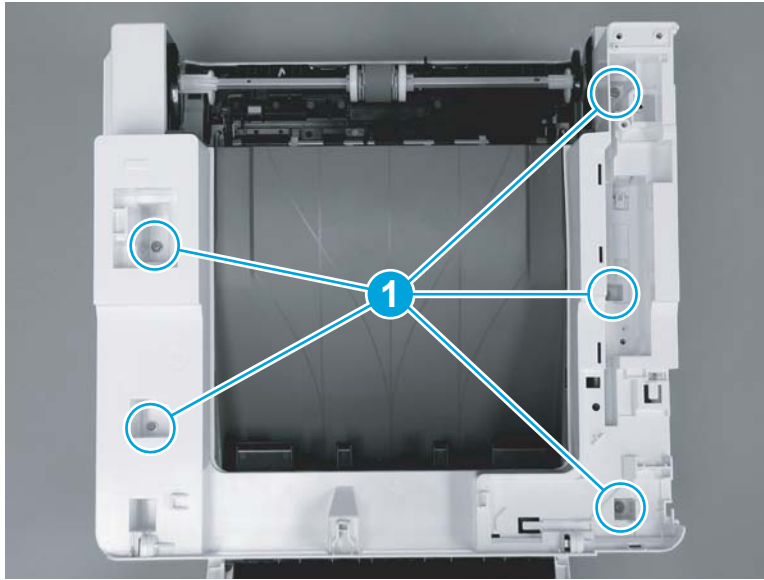

Step 13: Install the control panel (M427/M246)

 **NOTE:** The step is for the M427/M426 printer. For the M403/M402, skip this step and go to [Step 15: Install the right cover on page 602](#).

1. Slide the control-panel FFC cover into the slot in the top cover (next to the document feeder support arm) to install it.

Figure 1-1085 Install the control-panel FFC cover

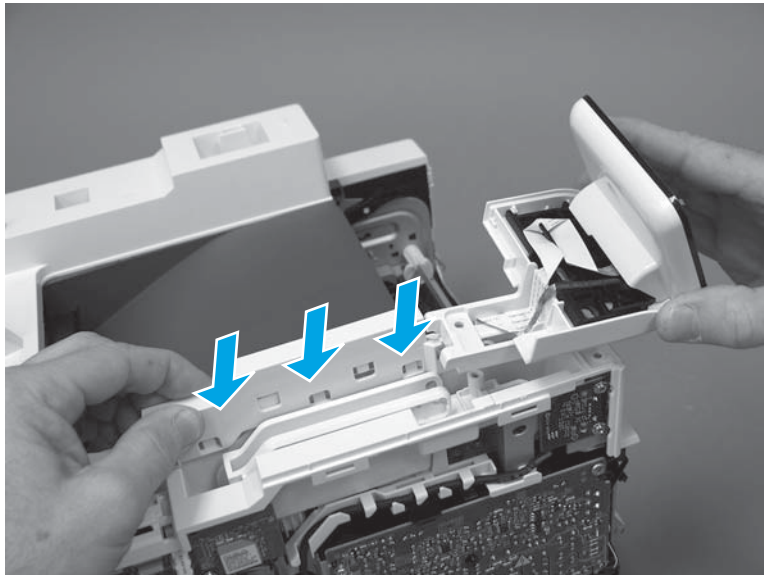

2. Install the control-panel assembly on the top cover.

Figure 1-1086 Install the control-panel assembly

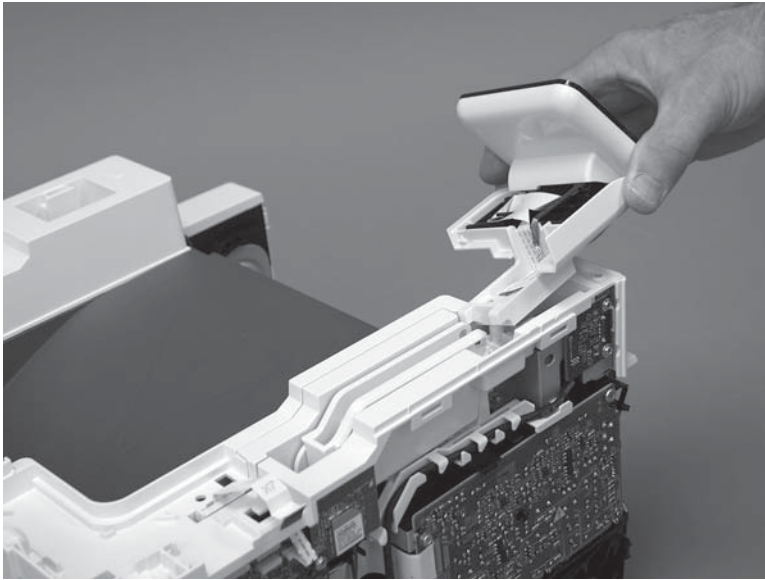

3. Move the FFC out of the way, and then install two screws (callout 1).

Figure 1-1087 Install two screws

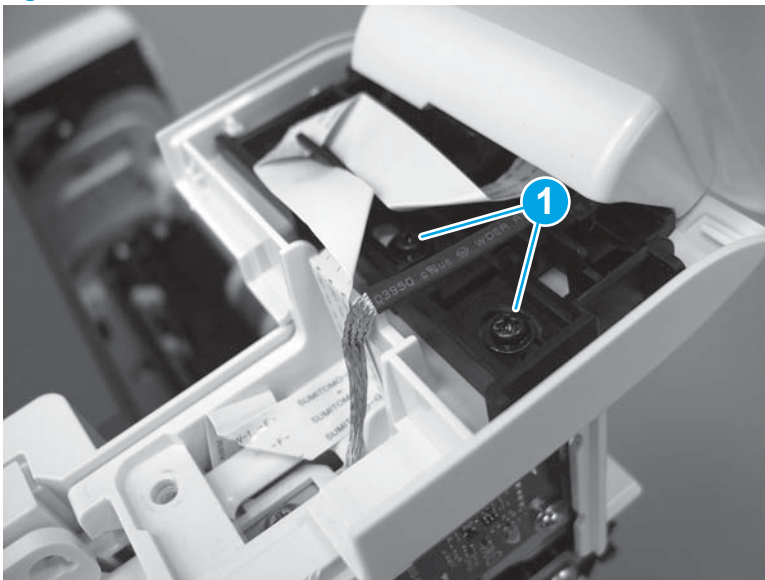

4. Install one grounding screw (callout 1), and then make sure that the ground cable (callout 2) is properly routed.

Figure 1-1088 Remove one screw

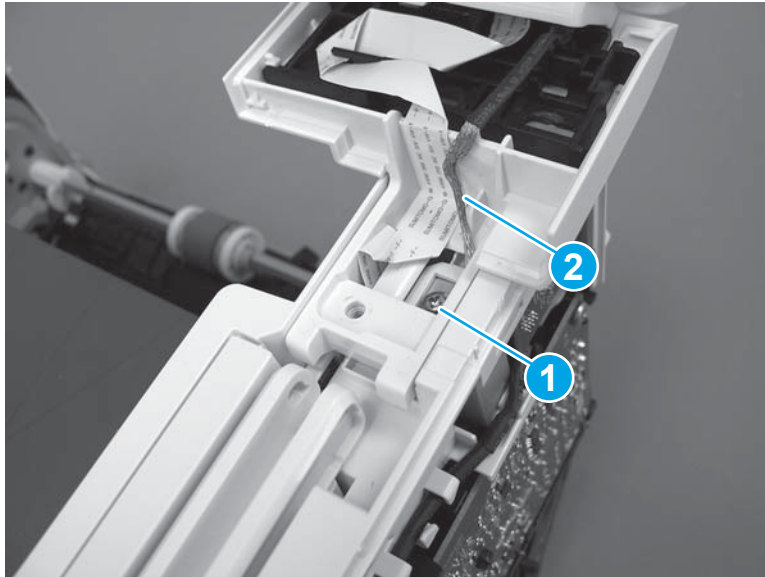

5. Install the control-panel cable cover.

Figure 1-1089 Install the cover

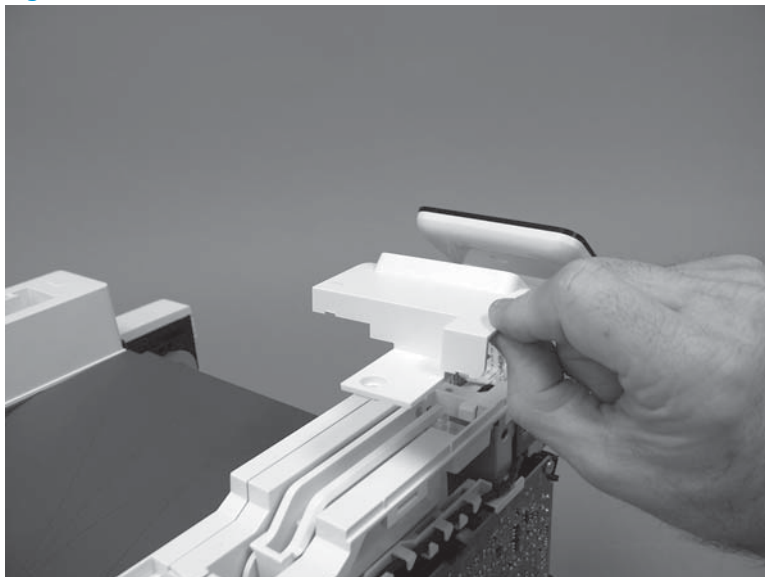

6. Make sure that the two tabs (callout 1) on the cover snap into place.

Figure 1-1090 Engage two tabs

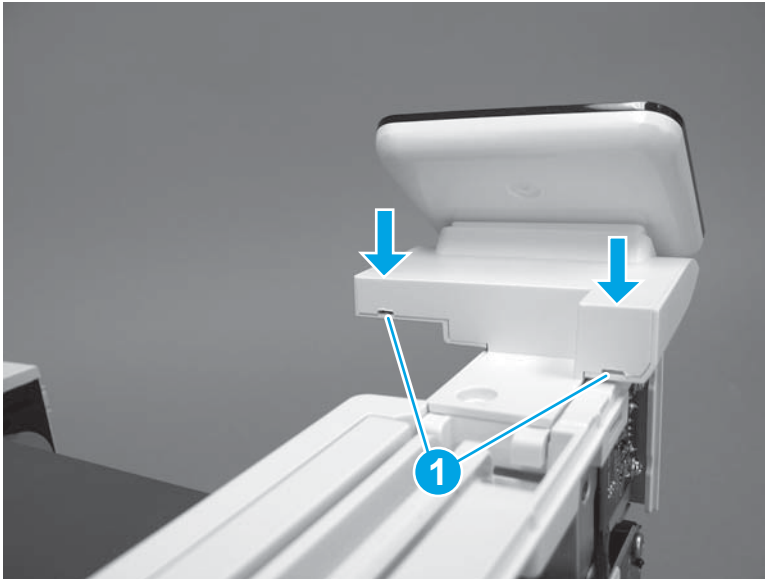

7. Install one screw (callout 1).

Figure 1-1091 Install one screw

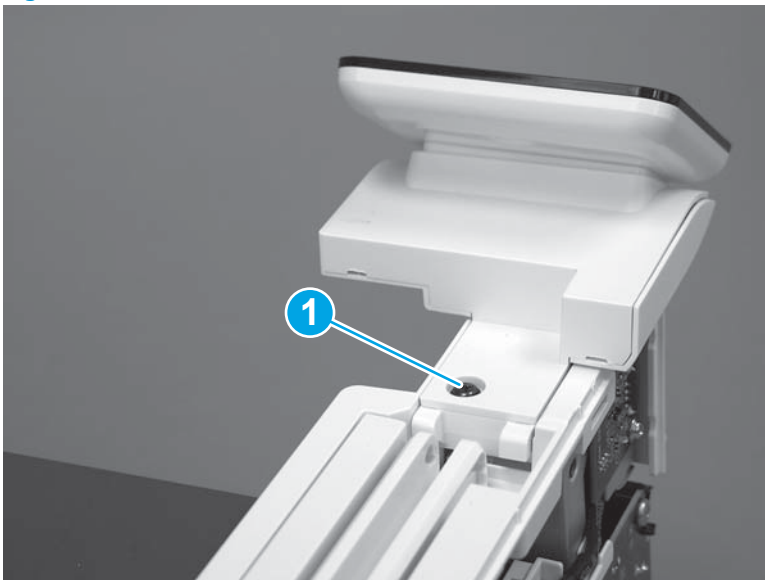

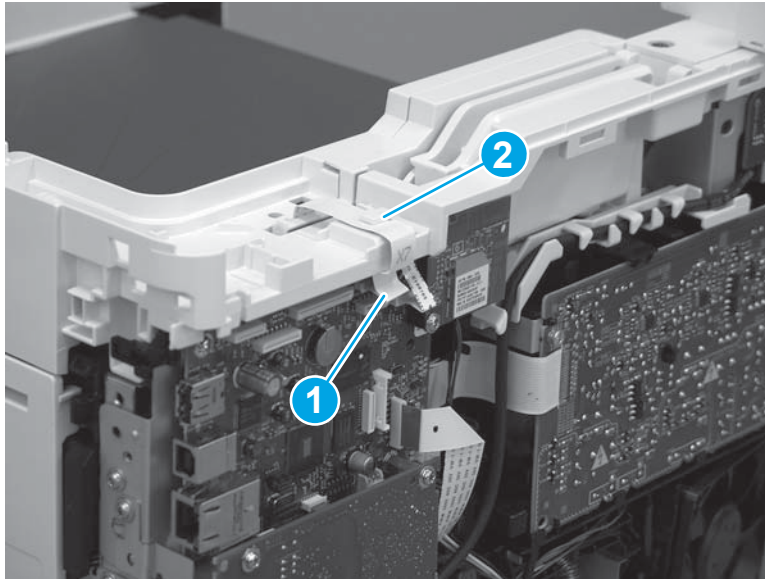

8. Install the FFC in the retainer (callout 1), and then connect one FFC (callout 2; J114).

Figure 1-1092 Connect one connector



Step 14: Install the integrated scanner assembly (M427/M246)

 **NOTE:** The step is for the M427/M426 printer. For the M403/M402, skip this step and go to [Step 15: Install the right cover on page 602](#).

 **NOTE:** M427/M426 models only. The integrated scanner assembly (ISA) includes the sub-scanner assembly (SSA) and the automatic document feeder (ADF).

1. Position the ISA on the printer.

Figure 1-1093 Position the ISA on the printer

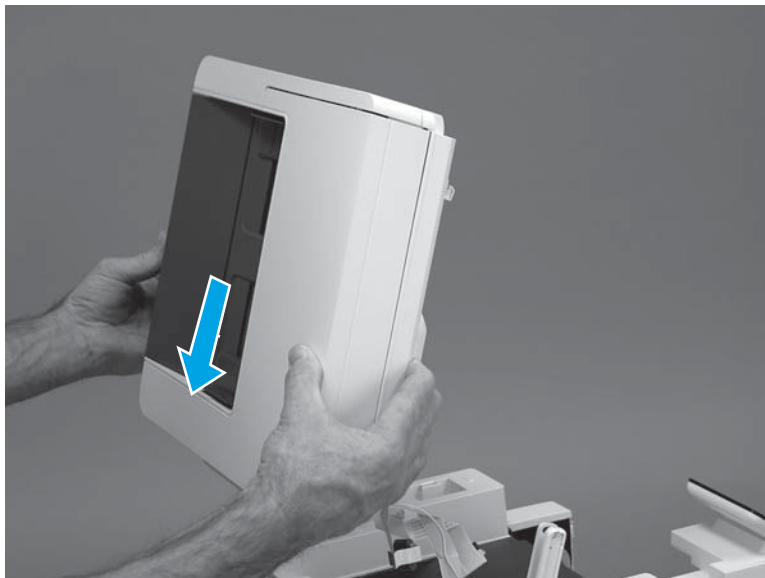

2. Engage the hinge pins on the ISA with the holders in the top cover (callouts 1/2), and then slide the ISA as shown to engage them

Figure 1-1094 Engage the hinge pins with the holders

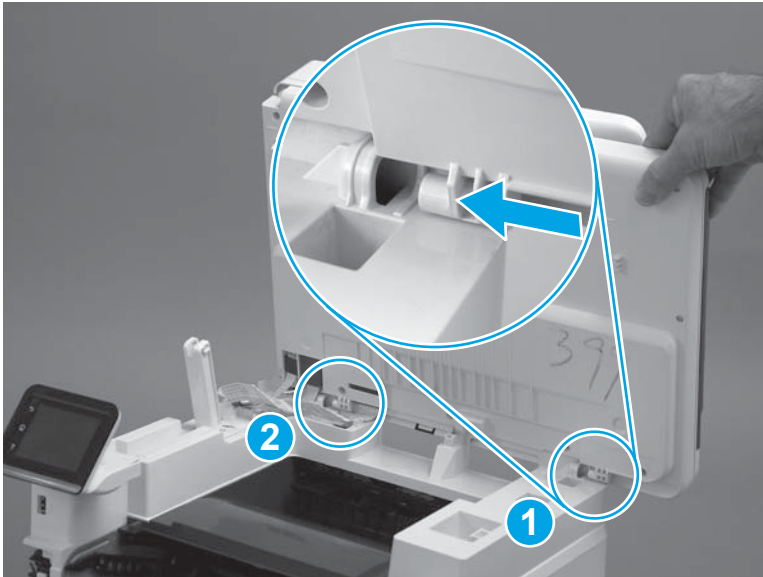

3. Rotate the ISA towards the front of the printer until it rests on the ISA lift assembly (callout 1).

Figure 1-1095 Rotate the ISA towards the front of the printer



4. Pass the ground wire through the opening in the top cover.

Figure 1-1096 Pass the wire through the opening

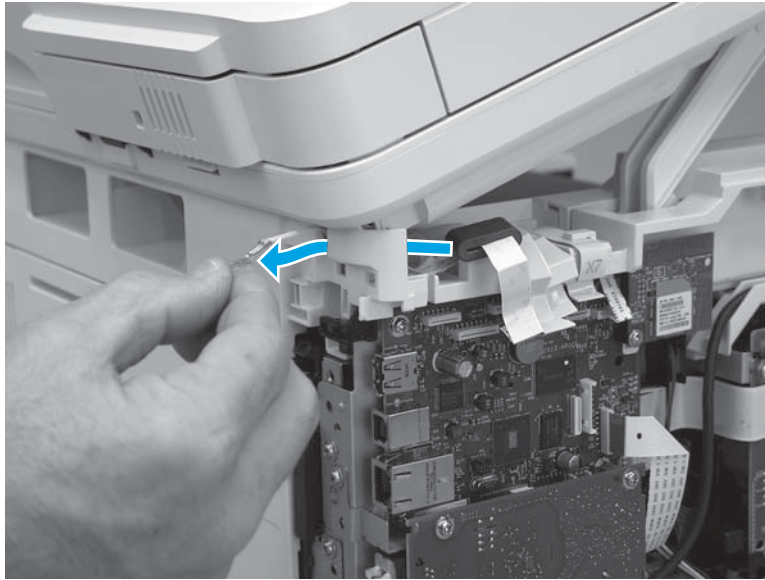

5. Install one screw (callout 1).

Figure 1-1097 Install one screw

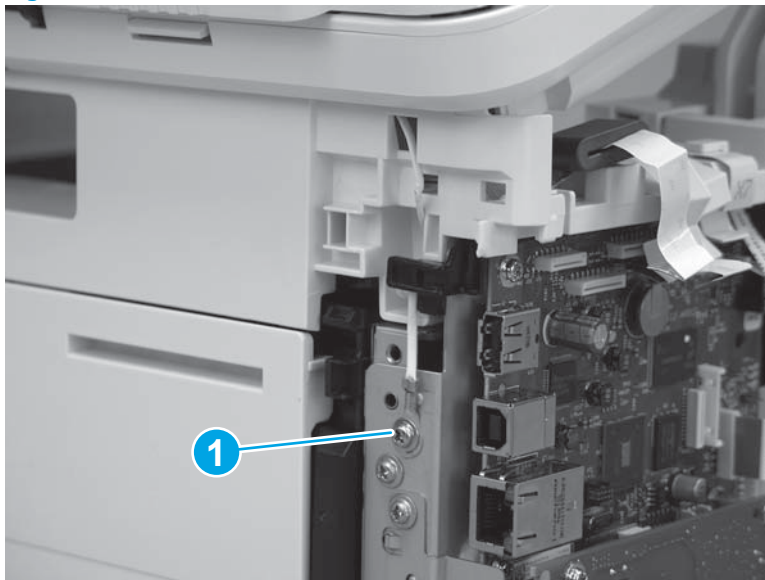

6. Install the ISA lift assembly slider pin.

 **Reinstallation tip:** Align the keyed portion of the locking pin with the slot and hole in the support arm.

Figure 1-1098 Install the slider pin



7. Rotate the slider pin (callout 1) towards the rear of the printer until the tab (callout 2) snap into place.

Figure 1-1099 Secure the slider pin

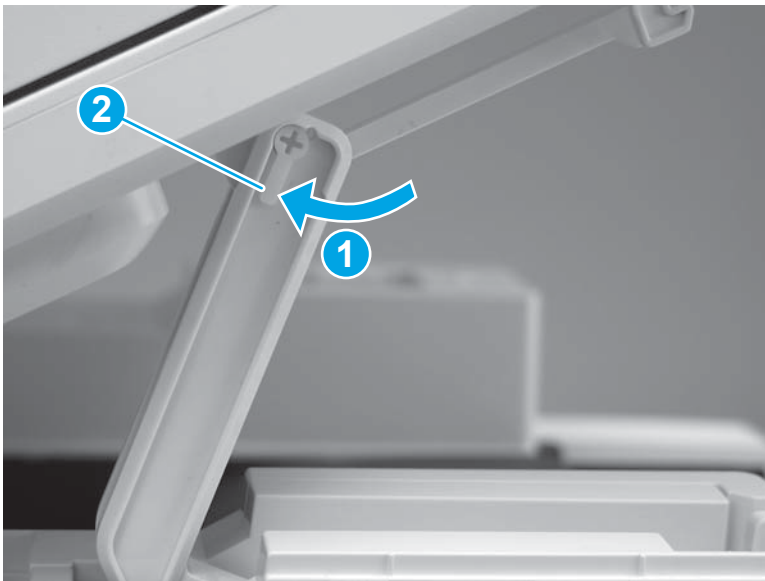

8. Install the ferrite (callout 1) in the holder, and then connect three FFCs (callout 2).

Figure 1-1100 Connect three FFCs

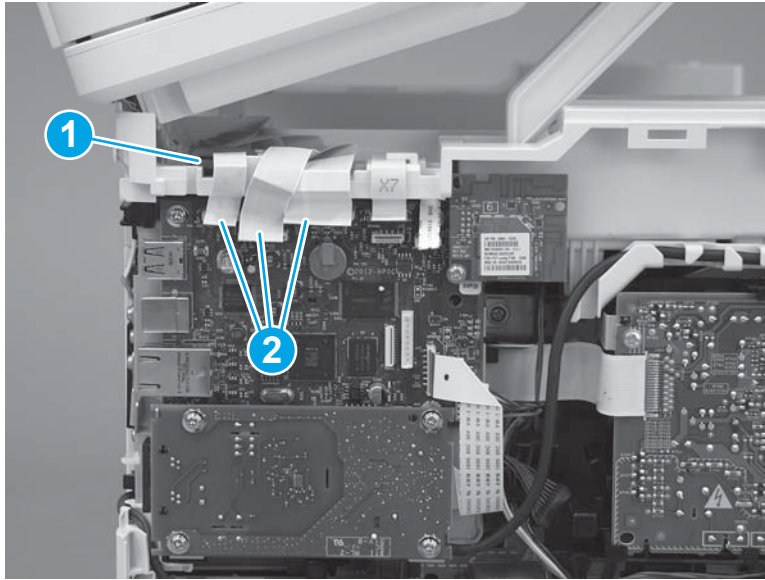

9. Position the rear edge of the ISA flat-flexible cable (FFC) cover on the printer (callout 1), and then rotate it down (callout 2) until it snaps into place.

Figure 1-1101 Install the ISA FFC cover

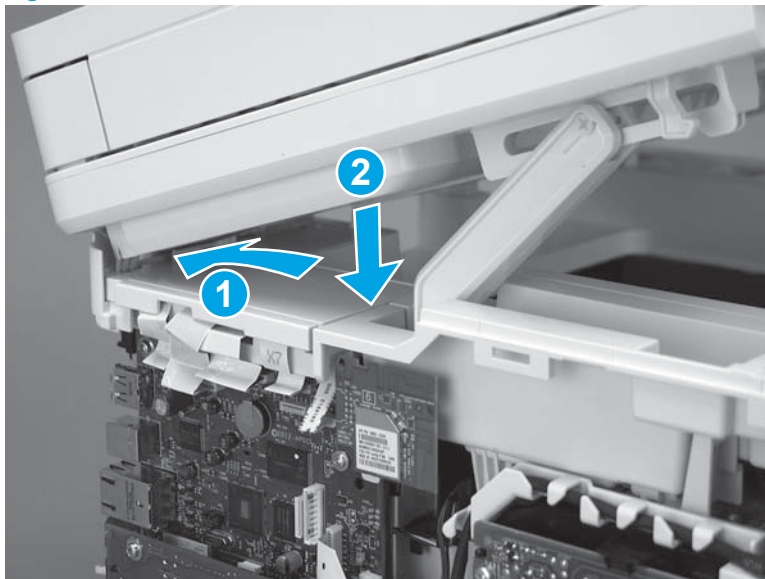

10. Lower the ISA.

Figure 1-1102 Lower the ISA

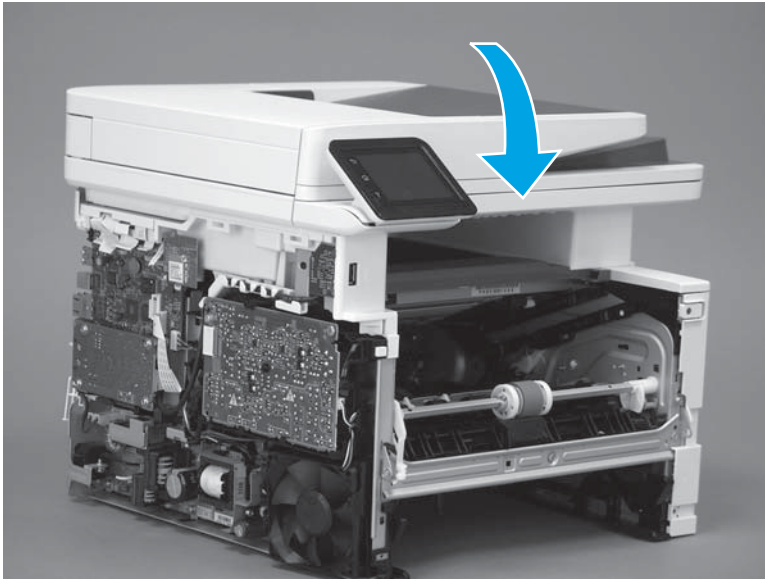

Step 15: Install the right cover

1. Position the cover (callout 1) on the printer, and then engage two bosses (callout 2).

Figure 1-1103 Install the cover

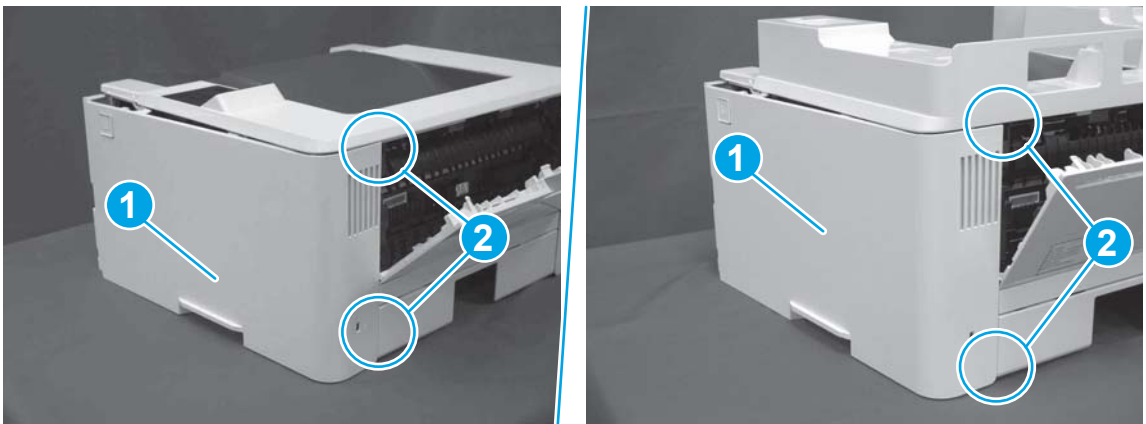

2. Rotate the front of the cover onto the printer (callout 1), engage three (callout 2) tabs, and then engage two bosses (callout 3).

Figure 1-1104 Engage two bosses and one tab

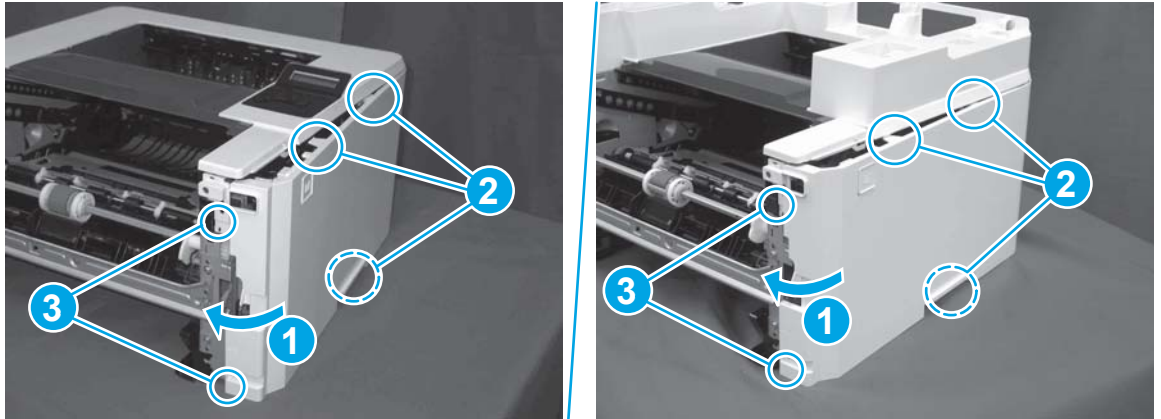

3. Make sure that the power switch (callout 1) and cartridge door assembly button (callout 2) correctly function.



NOTE: Remove, and then reinstall the cover if the switch or button does not correctly function.

Figure 1-1105 Check the power switch and cartridge door assembly button

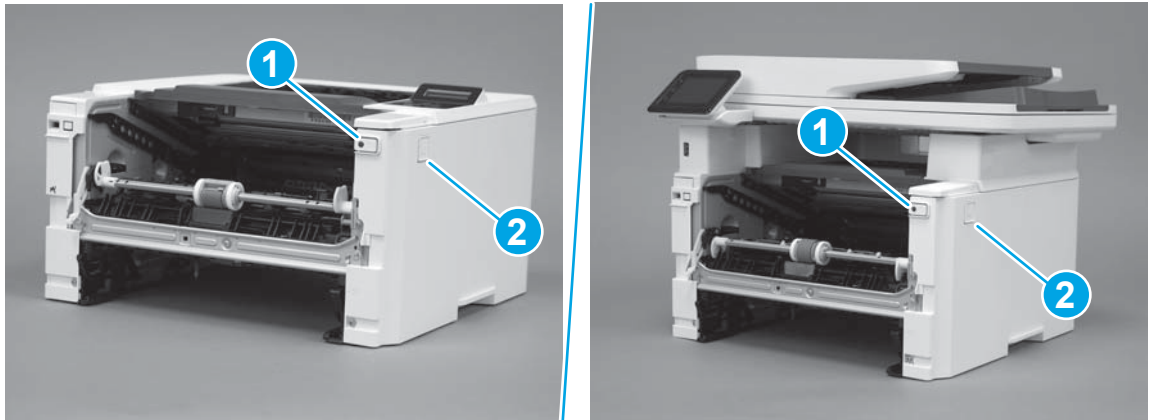

4. Install one screw (callout 1).

Figure 1-1106 Install one screw



Step 16: Install the left cover

1. At the front of the printer, do one of the following:
 - **M403/M402:** Position the cover on the printer (callout 1), and then engage two bosses (callout 2).
 - **M427/M426:** Position the cover on the printer (callout 3), engage one tab (callout 4), and then engage two bosses (callout 4).

Figure 1-1107 Install the cover

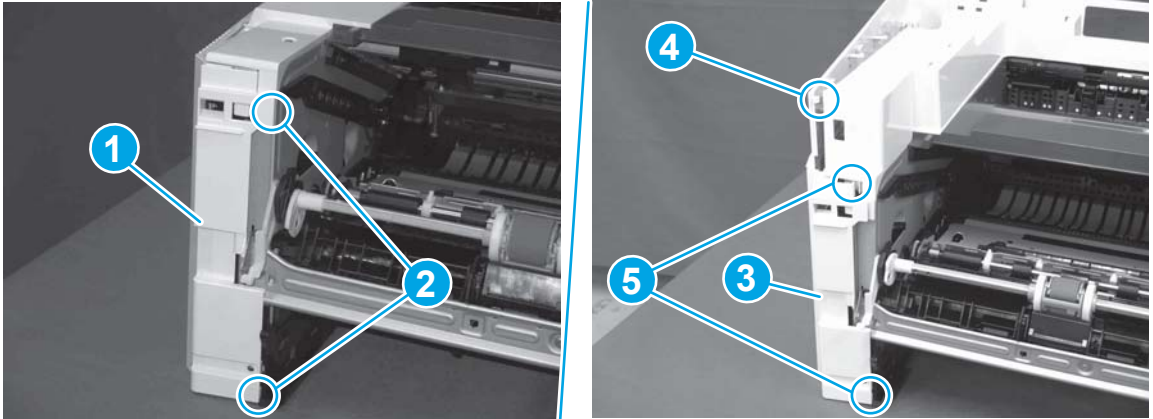

2. Carefully rotate the rear of the cover onto the printer (callout 1), engage three tabs (callout 2), and then engage two bosses (callout 3).

Figure 1-1108 Engage three tabs and two bosses

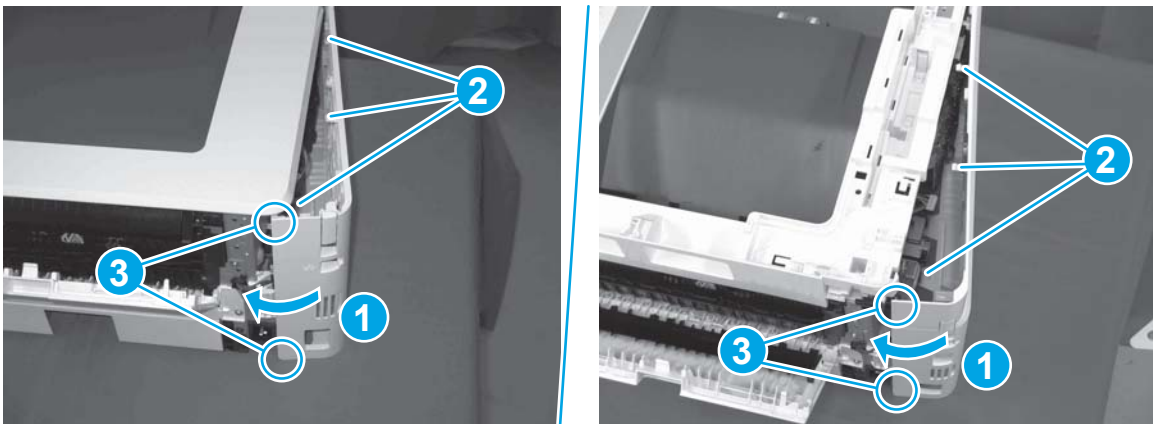

3. Install one screw (callout 1).

Figure 1-1109 Install one screw

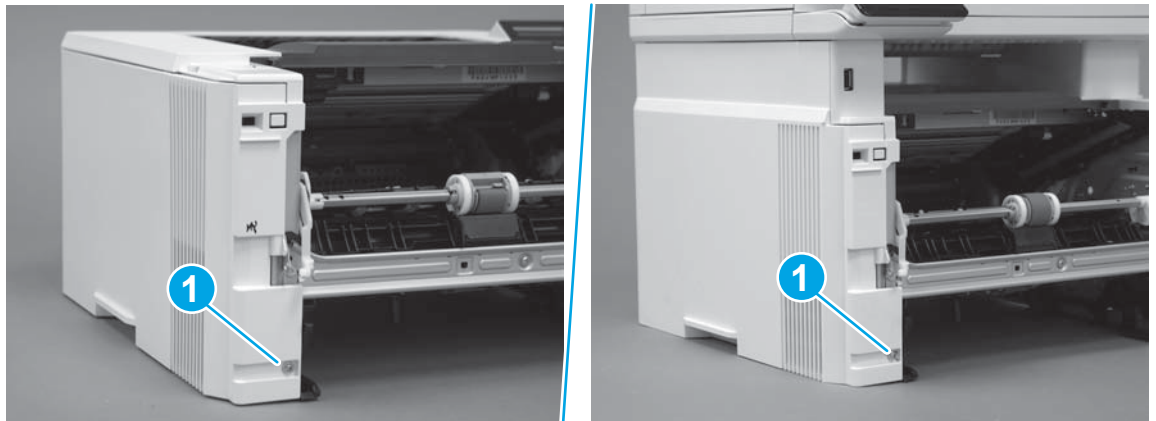

Step 17: Install the cartridge door assembly

 **Reinstallation tip:** After a replacement door is installed, make sure to install the nameplate (supplied in the kit) corresponding to the printer name on the door.

1. Position the door close to the printer, and then engage the keyed pin on the left-side retainer arm with the hole in the door.

Figure 1-1110 Engage the left-side retainer arm

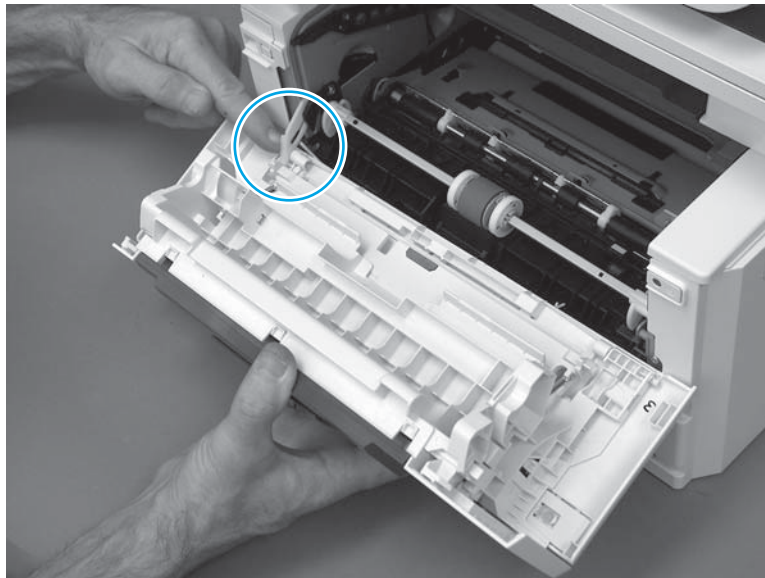

2. Engage the right-side door hinge pin with the hole in the chassis (callout 1).

Figure 1-1111 Install the door

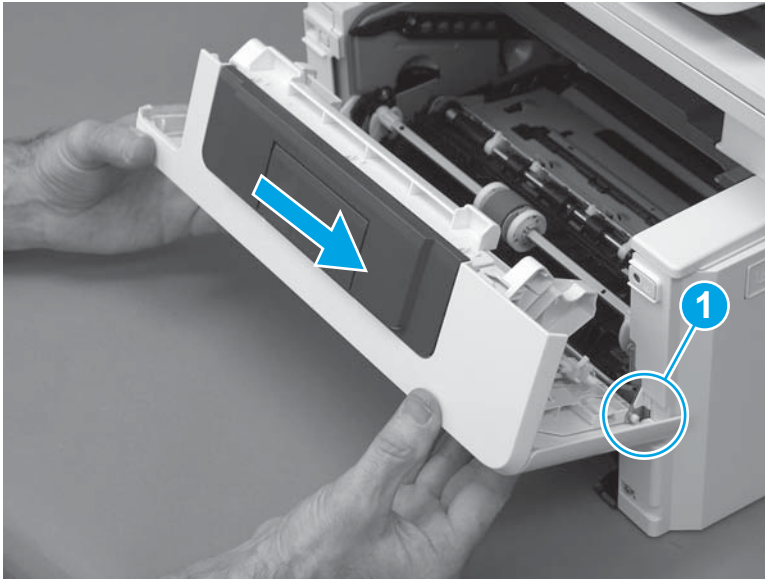

3. Install the link (callout 1).

 **IMPORTANT:** Make sure that the link snaps into place on the arm (callout 2). The link actuates the fuser pressure-release mechanism.

Figure 1-1112 Install the pressure-release link

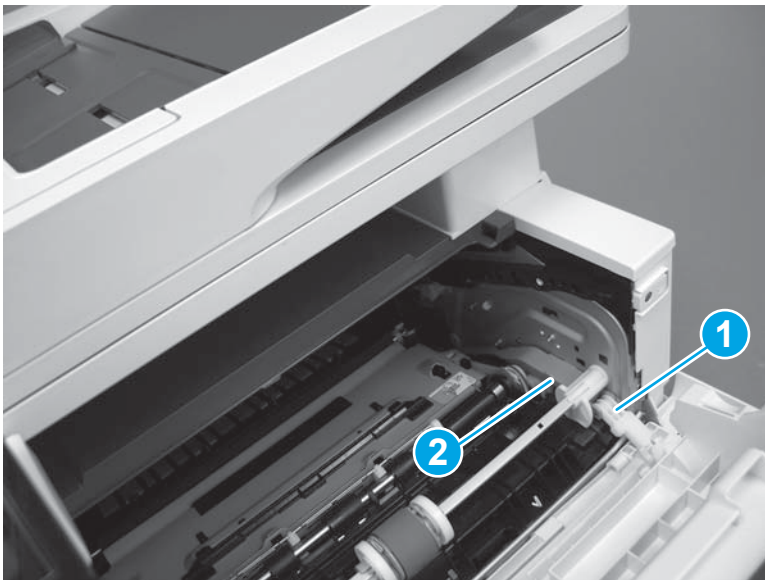

4. Slide the guide into the printer (callout 1), and then make sure that the tab (callout 2) snaps into place to secure the guide to the chassis.

Figure 1-1113 Install the guide

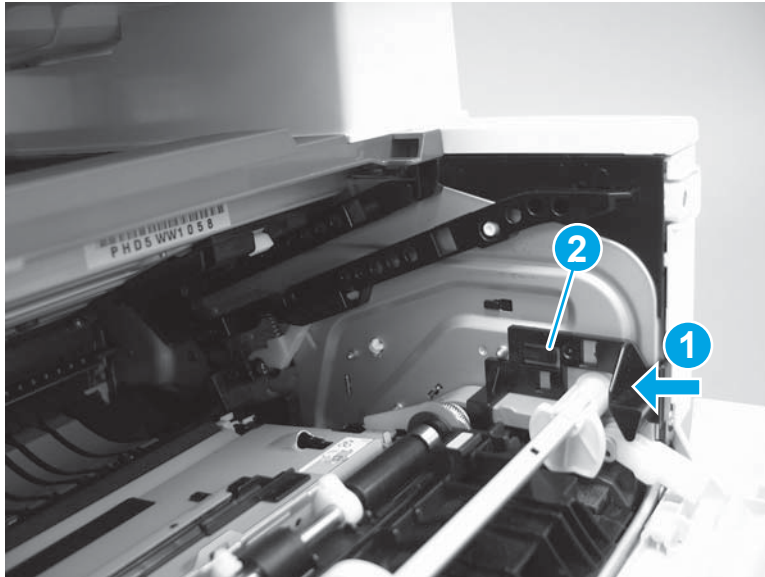

5. Position the shaft on the door, and then align the left-side hinge on the door with the hole in the chassis (callout 1).

Figure 1-1114 Align the hinge

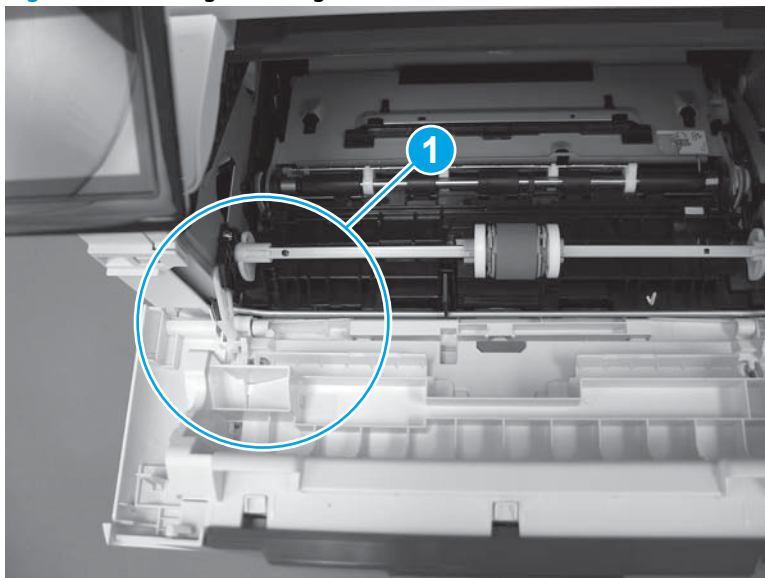

6. Push the shaft towards the left side of the printer to install it (callout 1).

 **Reinstallation tip:** Make sure that the support shaft is fully installed and correctly orientated (callout 2) so that it will not interfere with the door opening and closing.

Figure 1-1115 Install the support shaft



Step 18: Install Tray 2

- ▲ Slide the tray straight into the printer to install it.

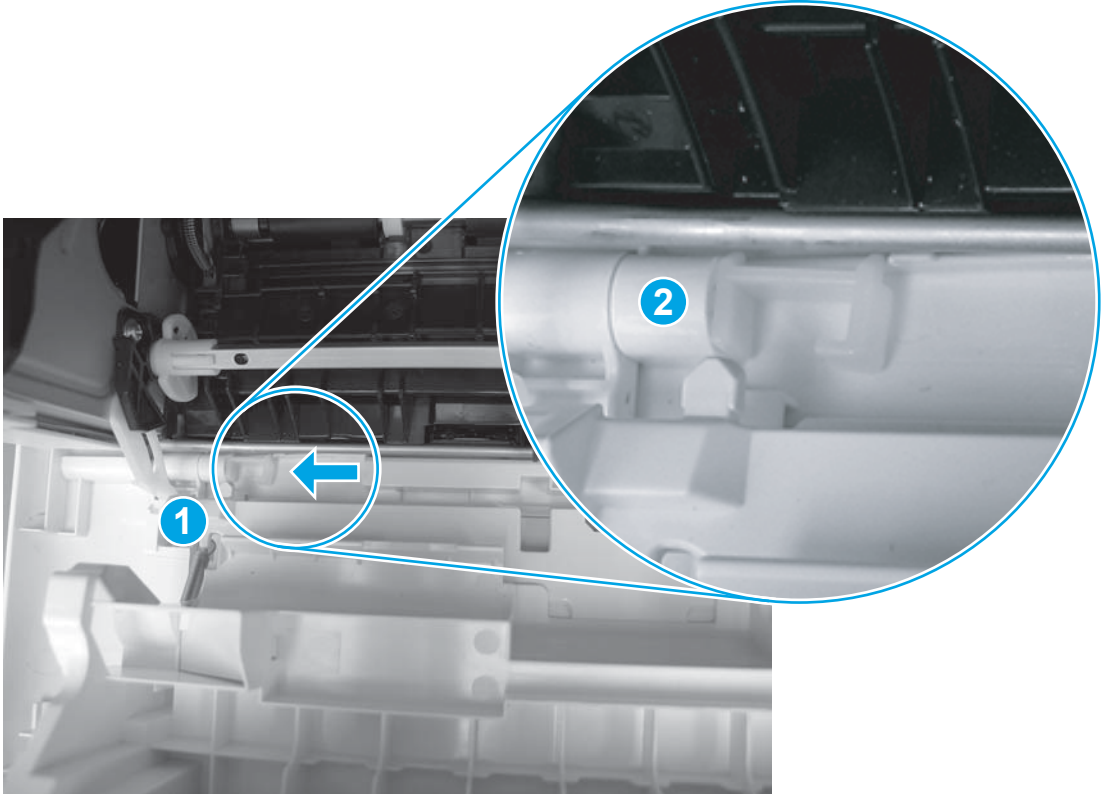
Figure 1-1116 Install the tray



Removal and replacement: NFC FFC

- [Introduction](#)
- [Step 1: Remove Tray 2](#)
- [Step 2: Remove the cartridge door assembly](#)
- [Step 3: Remove the left cover](#)
- [Step 4: Remove the right cover](#)
- [Step 5: Remove the integrated scanner assembly \(M427/M246\)](#)
- [Step 6: Remove the control panel \(M427/M246\)](#)
- [Step 7: Remove the top cover \(M427/M426\)](#)
- [Step 8: Remove the NFC PCA cover \(M427/M426\)](#)
- [Step 9: Remove the top cover \(M403/M402\)](#)
- [Step 10: Remove the paper delivery tray \(output bin\)](#)
- [Step 11: Remove the NFC PCA](#)
- [Step 12: Remove the NFC FFC](#)
- [Step 13: Unpack the replacement assembly](#)
- [Step 14: Install the NFC FFC](#)
- [Step 15: Install the NFC PCA](#)
- [Step 16: Install the paper delivery tray \(output bin\)](#)
- [Step 17: Install the top cover \(M403/M402\)](#)
- [Step 18: Install the NFC PCA cover \(M427/M426\)](#)
- [Step 19: Install the top cover \(M427/M426\)](#)
- [Step 20: Install the control panel \(M427/M246\)](#)
- [Step 21: Install the integrated scanner assembly \(M427/M246\)](#)
- [Step 22: Install the right cover](#)
- [Step 23: Install the left cover](#)
- [Step 24: Install the cartridge door assembly](#)
- [Step 25: Install Tray 2](#)

Introduction

This document provides the procedures to remove and replace the near field communication (NFC) flat-flexible cable (FFC; M426fdw/M403dn models only).

Before performing service

Turn the printer power off

- Disconnect the power cable.

 **WARNING!** To avoid damage to the printer, turn the printer off, wait 30 seconds, and then remove the power cable before attempting to service the printer.

Use the table below to identify the correct part number for your printer. To order the part, go to www.hp.com/buy/parts.

NFC FFC part number	
RK2-6949-000CN	NFC FFC (M427/M426; wireless models)
RK2-6947-000CN	NFC FFC (M403/M402; wireless models)

Required tools

- #2 Phillips screwdriver with a magnetic tip.

After performing service

Turn the printer power on

- Connect the power cable.
- Use the power switch to turn the power on.

Post service test

Make sure that the printer initializes to a **Ready** state.

Print a configuration page to make sure that the printer is functioning correctly.

Step 1: Remove Tray 2

- ▲ Pull the tray straight out of the printer to remove it.

Figure 1-1117 Remove the tray



Step 2: Remove the cartridge door assembly

 **NOTE:** If the toner cartridge was not removed prior to servicing the printer, remove it now.

1. Release one tab (callout 1), and then slide shaft (callout 2) in the direction the arrow indicates and remove it.

 **TIP:** It might be easier to release the support shaft by using a small flat-blade screwdriver.

Figure 1-1118 Release the support shaft

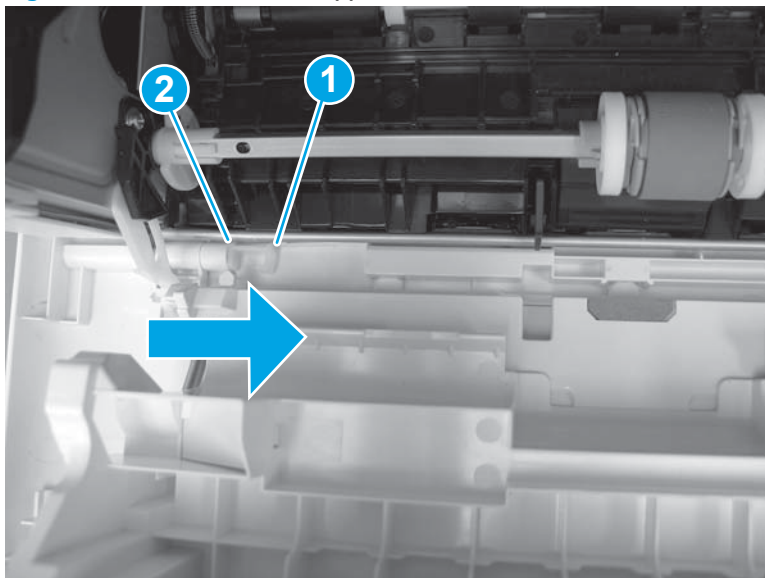

2. Release one tab (callout 1), and then slide the guide (callout 2) in the direction the arrow indicates and remove it.

Figure 1-1119 Remove the guide

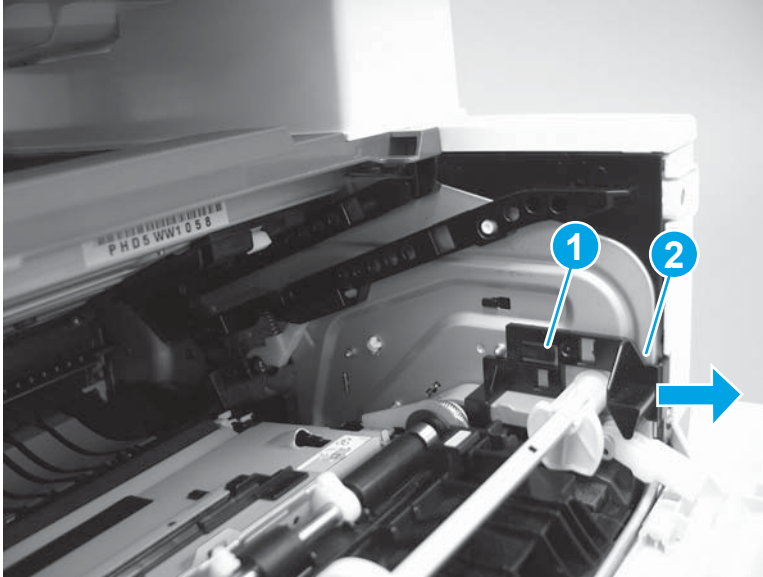

3. Remove the link arm (callout 1).

Figure 1-1120 Remove the link arm

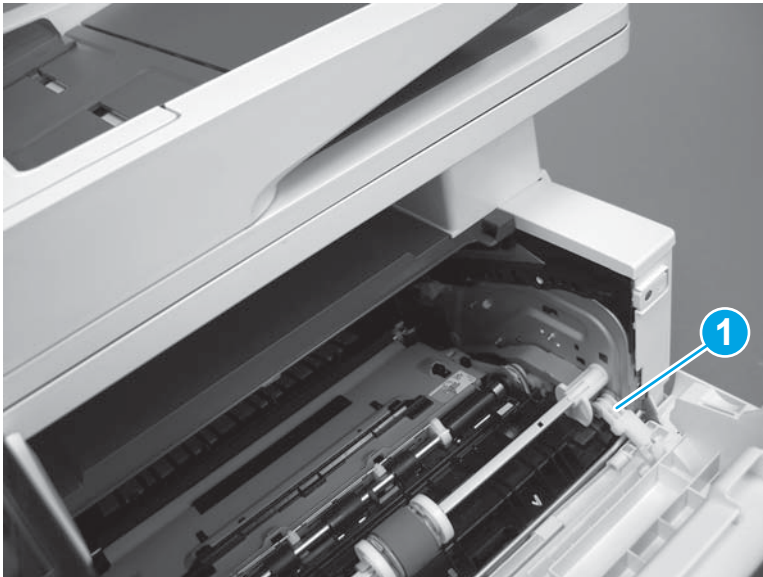

4. Slide the cartridge door assembly (callout 1) in the direction the arrow indicates and remove it.

Figure 1-1121 Remove the door

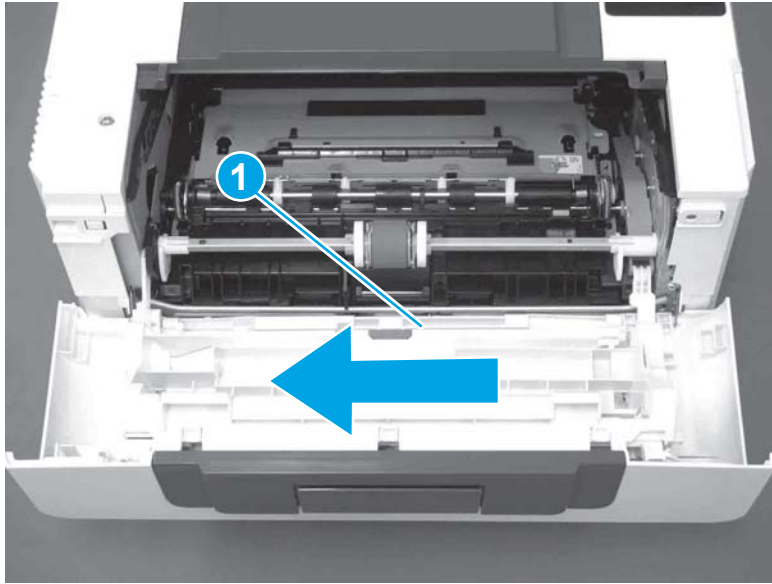

5. Remove the link (callout 1) from the cartridge door assembly (callout 2).

Figure 1-1122 Release the left-side retainer arm

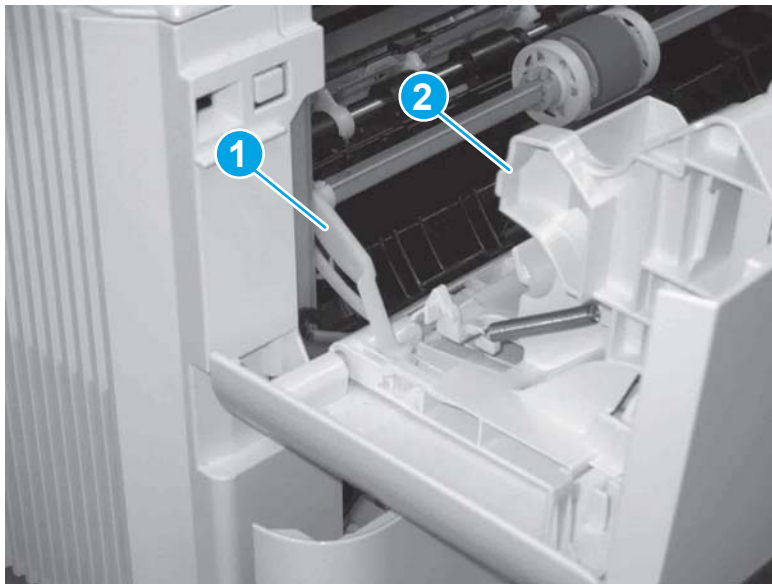

Step 3: Remove the left cover

1. Remove one screw (callout 1).

Figure 1-1123 Remove one screw

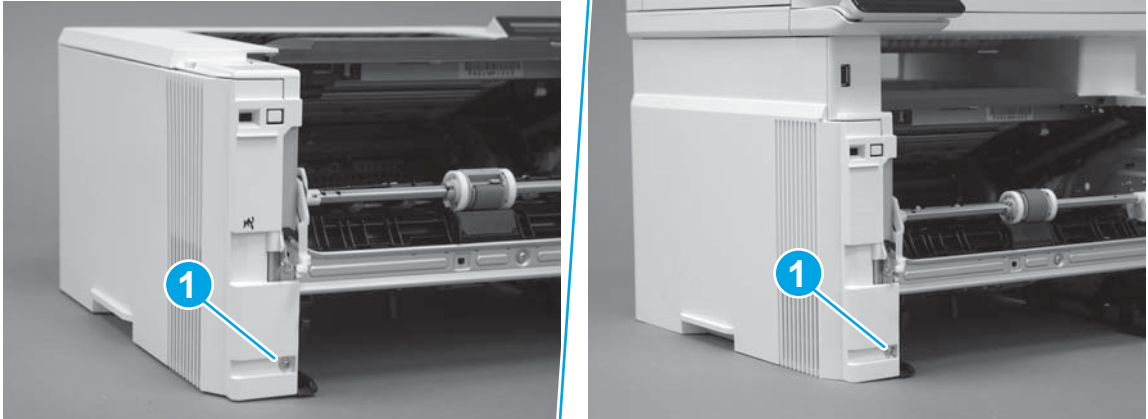

2. Open the rear door, release two bosses (callout 1), and then release three tabs (callout 2).

Figure 1-1124 Release two bosses and three tabs

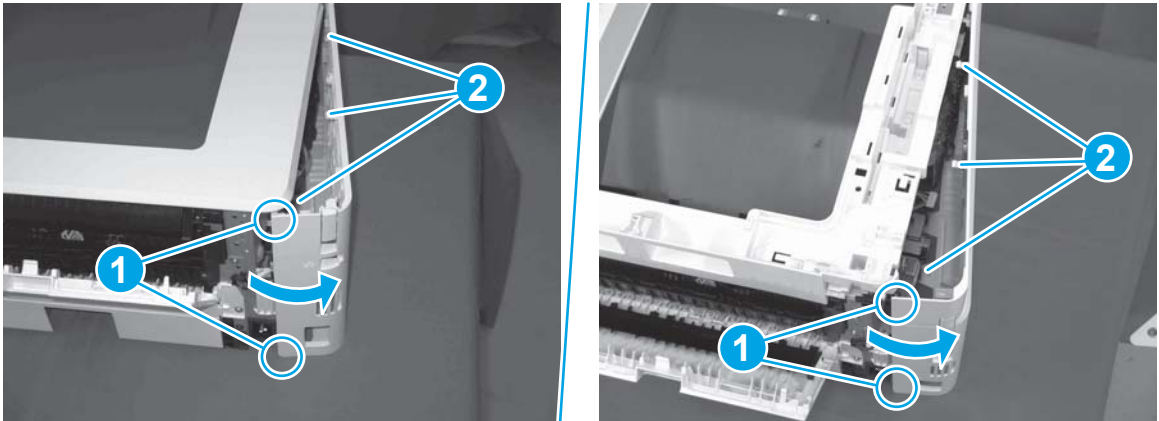

3. At the front of the printer, do one of the following:
 - **M403/M402:** Release two bosses (callout 1), and then remove the cover (callout 2).
 - **M427/M426:** Release one tab (callout 3), two bosses (callout 4), and then remove the cover (callout 5).

CAUTION: Be careful when releasing the upper bosses on the M427/M426 cover. One portion of the cover (callout 6) is fragile and is easily broken.

Figure 1-1125 Remove the cover

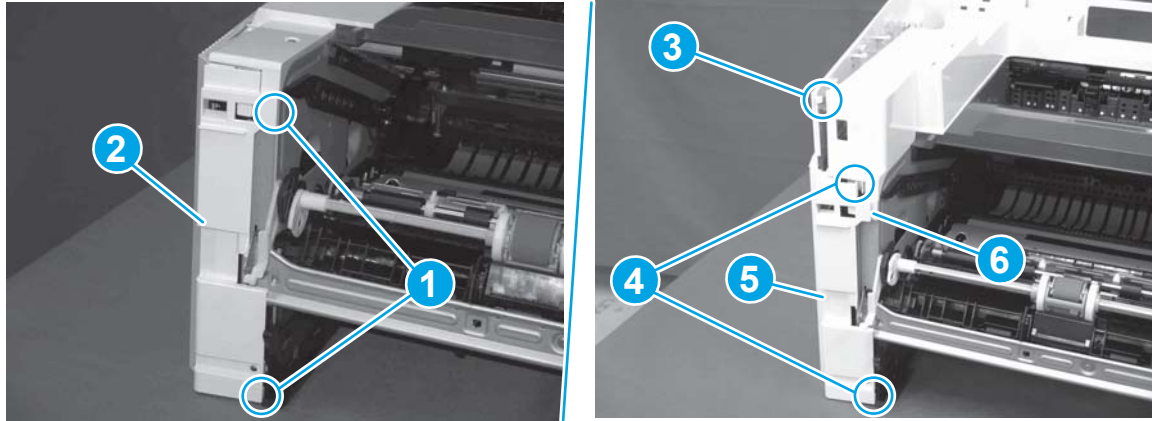

Step 4: Remove the right cover

1. Remove one screw (callout 1).

Figure 1-1126 Remove one screw



2. At the front of the printer, release two bosses (callout 1), and then release three tabs (callout 2).

Figure 1-1127 Release two bosses and three tabs

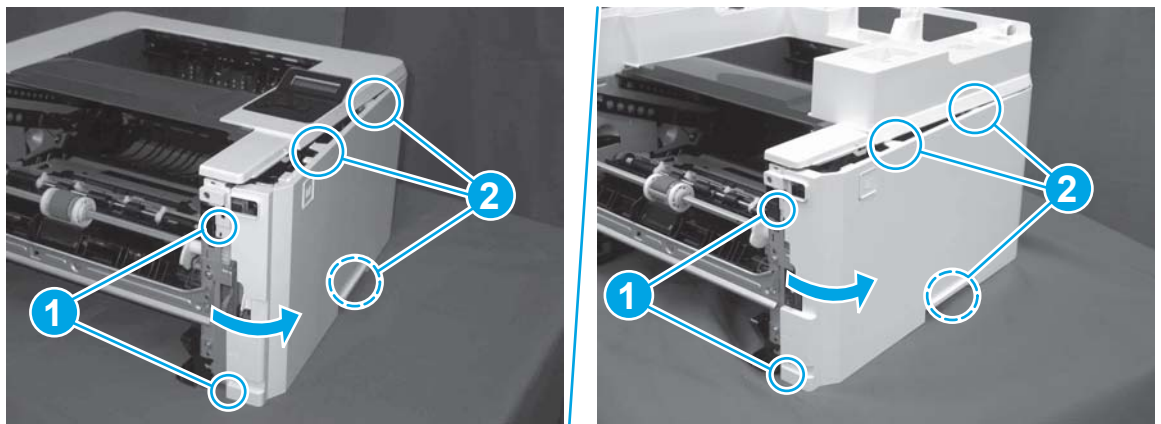

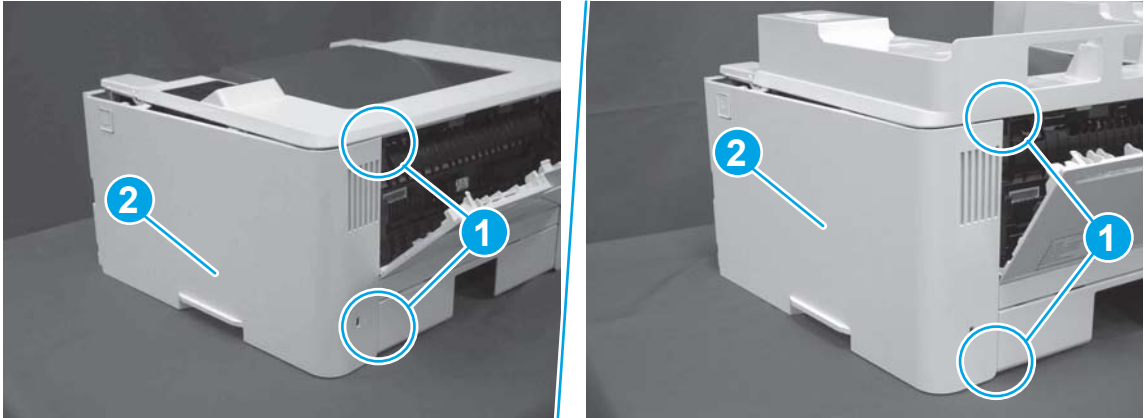

3. Open the rear door, release two bosses (callout 1), and then remove the cover (callout 2).

Figure 1-1128 Remove the cover



Step 5: Remove the integrated scanner assembly (M427/M246)

 **NOTE:** The step is for the M427/M426 printer. For the M403/M402, skip this step and go to [Step 9: Remove the top cover \(M403/M402\)](#) on page 627.

 **NOTE:** M427/M426 models only. The integrated scanner assembly (ISA) includes the sub-scanner assembly (SSA) and the automatic document feeder (ADF).

1. Raise the ISA.

Figure 1-1129 Raise the ISA

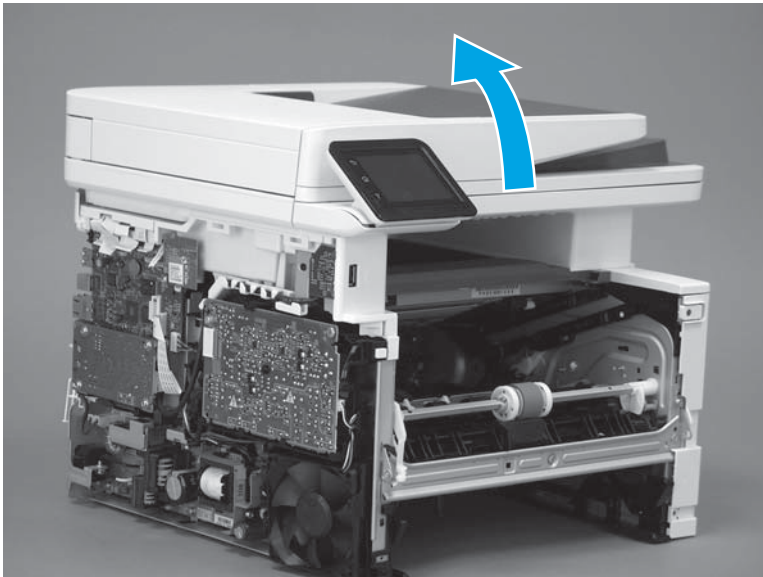

2. Release the ISA flat-flexible cable (FFC) cover (callout 1), and then remove it (callout 2).

Figure 1-1130 Remove the ISA FFC cover

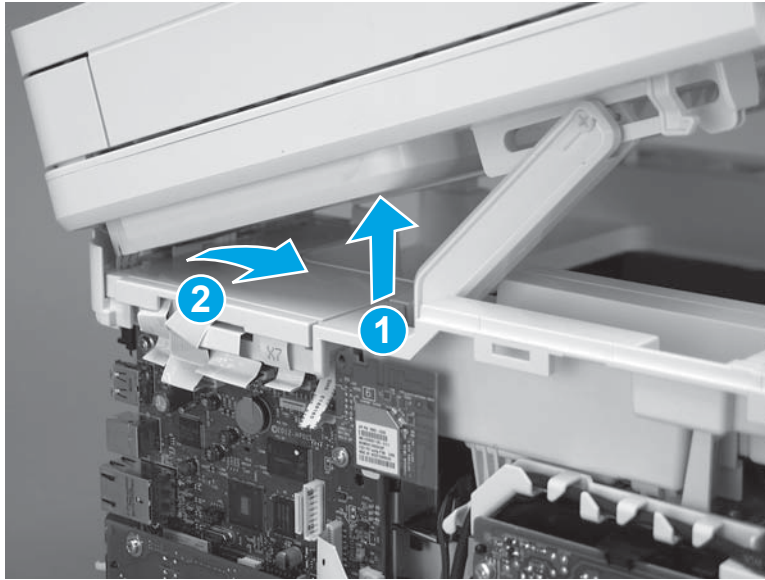

3. Disconnect three FFCs (callout 1), and then remove the ferrite (callout 2) from the holder.

CAUTION: The ferrite is not captive on the FFC. Do not lose the ferrite while handling the ISA.

Figure 1-1131 Disconnect three FFCs

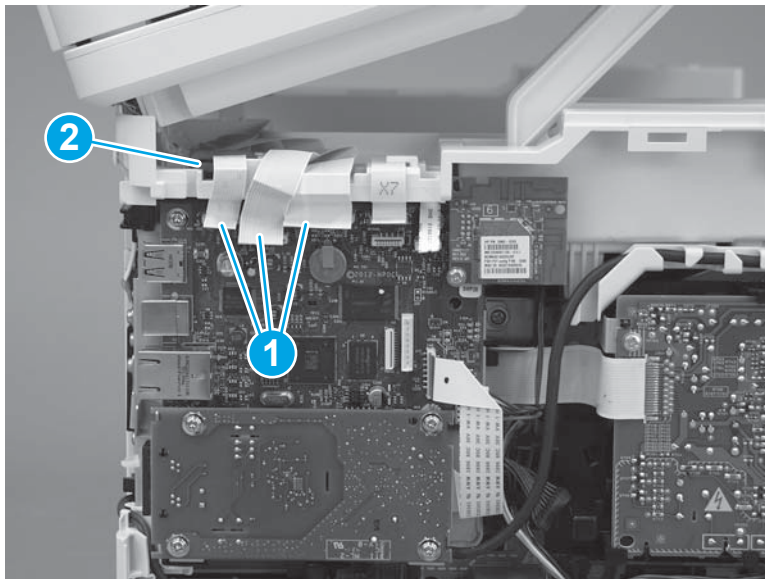

4. Remove one screw (callout 1).

Figure 1-1132 Remove one screw

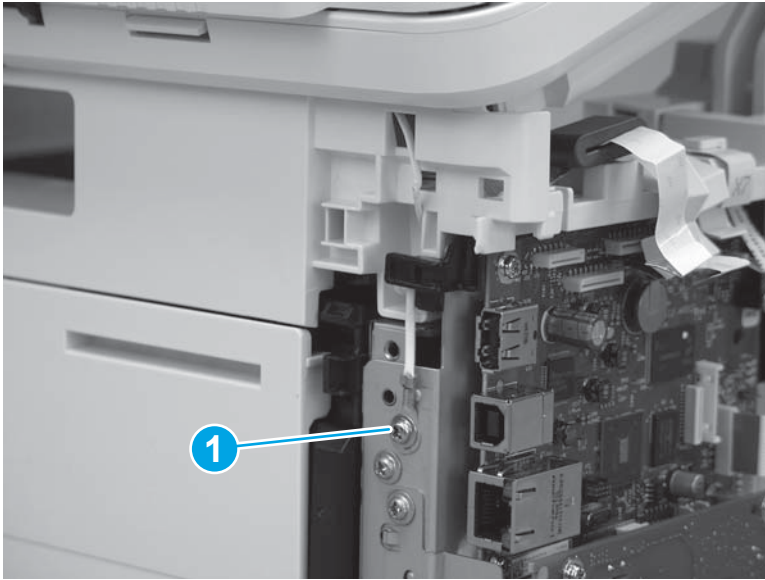

5. Pass the ground wire through the opening in the top cover.

Figure 1-1133 Pass the wire through the opening

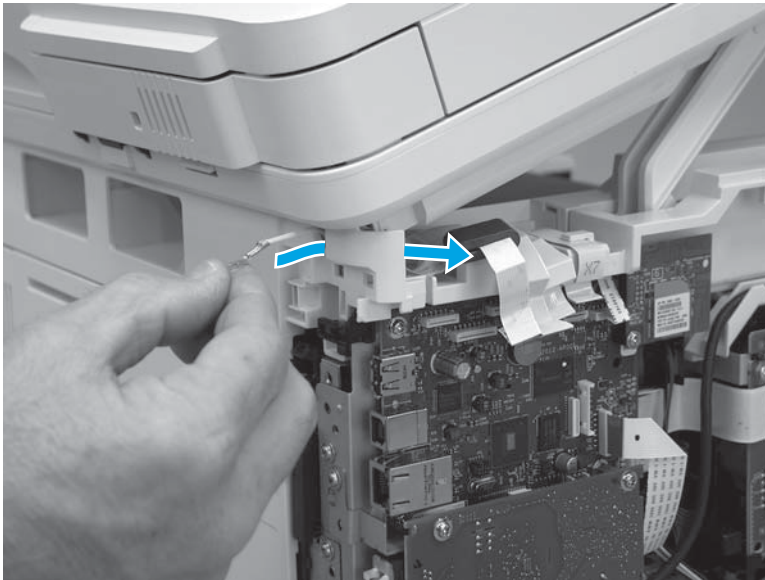

6. Release one tab (callout 1), and then rotate the ISA slider pin (callout 2) towards the front of the printer to release it.

Figure 1-1134 Release one tab and rotate the slider pin

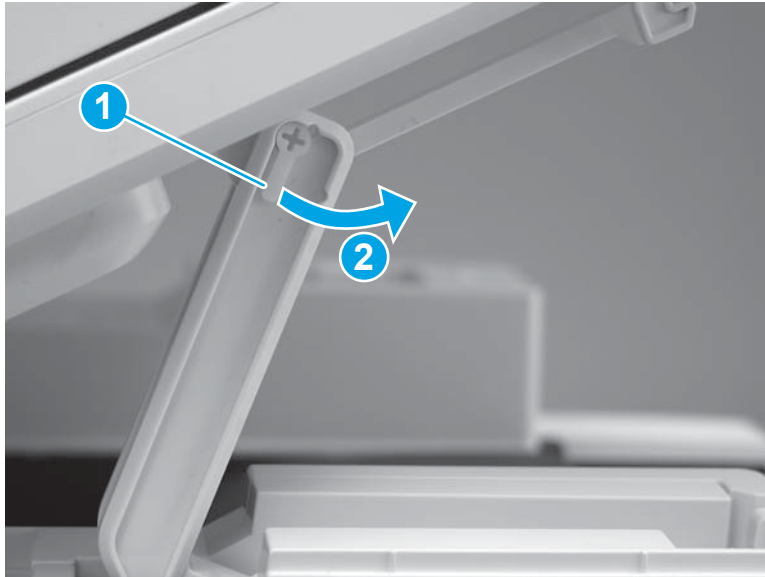

7. Remove the slider pin.

Figure 1-1135 Remove the slider pin

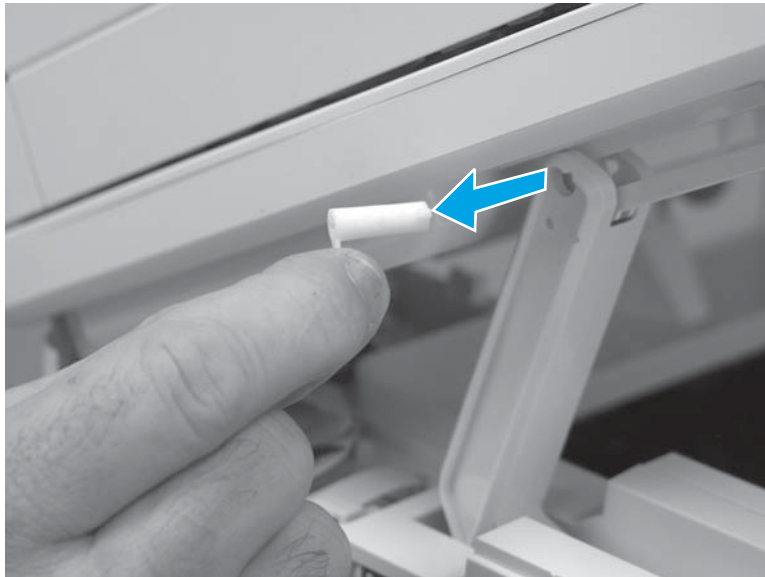

8. Rotate the ISA towards the rear of the printer until it stops.

Figure 1-1136 Rotate the ISA towards the rear of the printer



9. Slide the ISA as shown to release it.

Figure 1-1137 Release the ISA

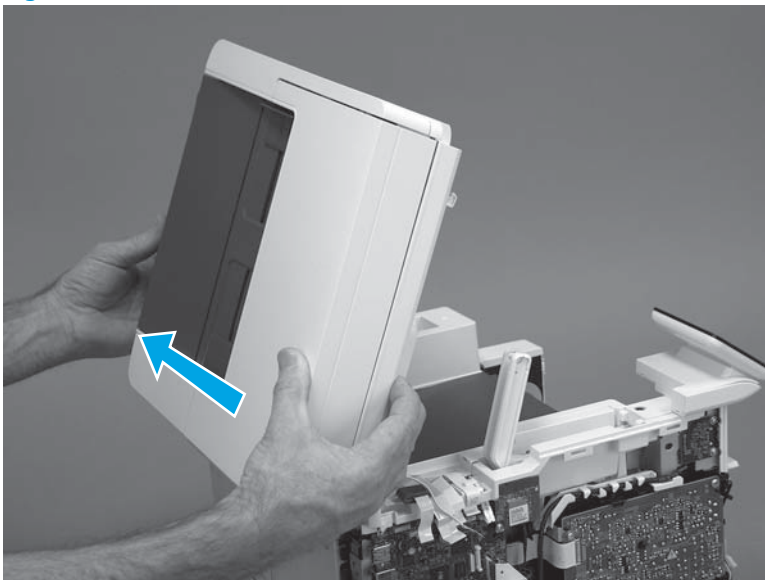

10. Remove the ISA.

Figure 1-1138 Remove the ISA

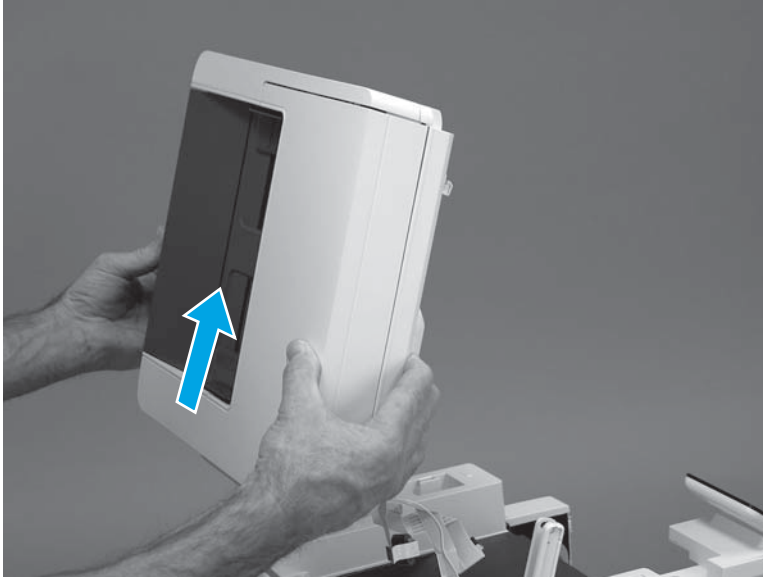

Step 6: Remove the control panel (M427/M246)

 **NOTE:** The step is for the M427/M426 printer. For the M403/M402, skip this step and go to [Step 9: Remove the top cover \(M403/M402\)](#) on page 627.

1. Disconnect one FFC (callout 1; J114), and then release the FFC from the retainer (callout 2).

Figure 1-1139 Disconnect one connector

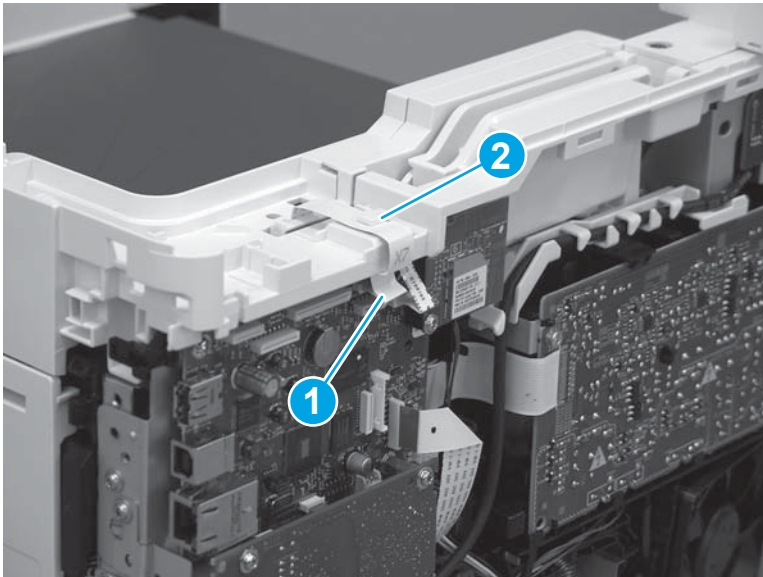

2. Remove one screw (callout 1).

Figure 1-1140 Remove one screw

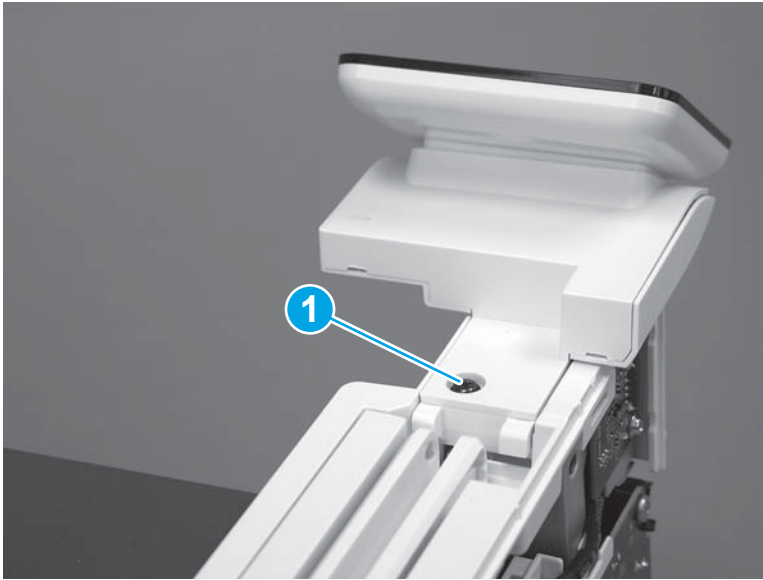

3. Use a small flat-blade screwdriver to release two tabs (callout 1) on the control-panel cable cover.

Figure 1-1141 Release two tabs

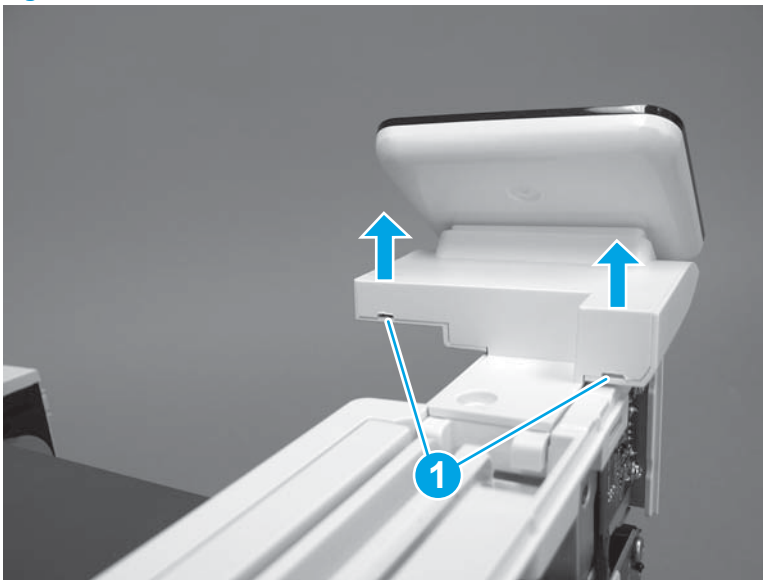

4. Remove the control-panel cable cover.

Figure 1-1142 Remove the cover

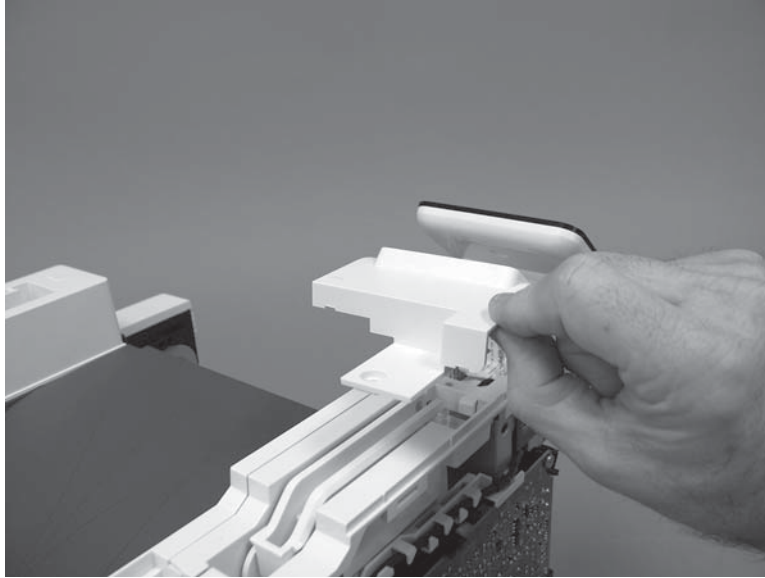

5. Remove one grounding screw (callout 1), and then move the ground cable (callout 2) out of the way.

Figure 1-1143 Remove one screw

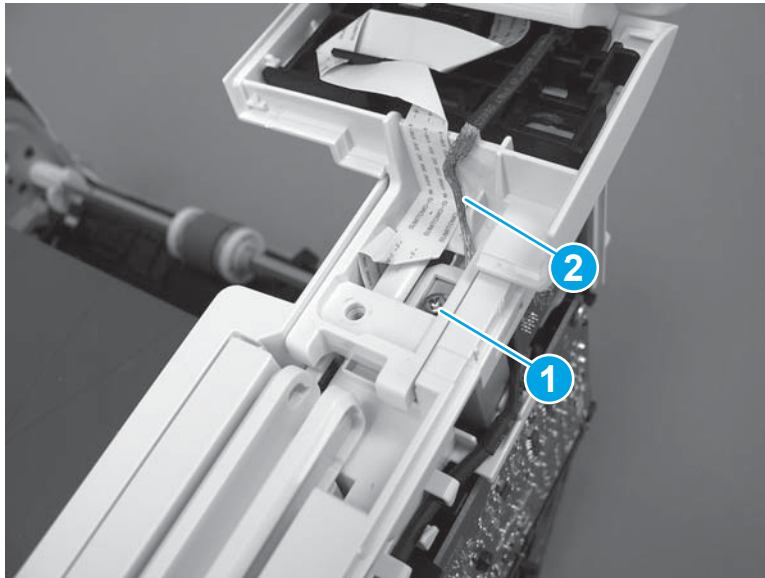

6. Move the FFC out of the way, and then remove two screws (callout 1).

Figure 1-1144 Remove two screws

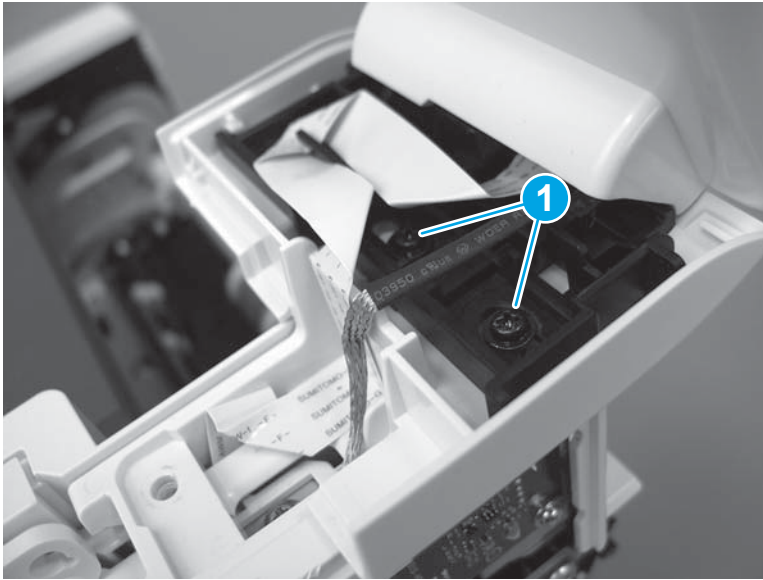

7. Slightly lift up the control-panel assembly to separate it from the top cover.

CAUTION: The control panel assembly is still connected to the printer by the FFC. Do not attempt to completely remove the assembly.

Figure 1-1145 Lift up the control-panel assembly

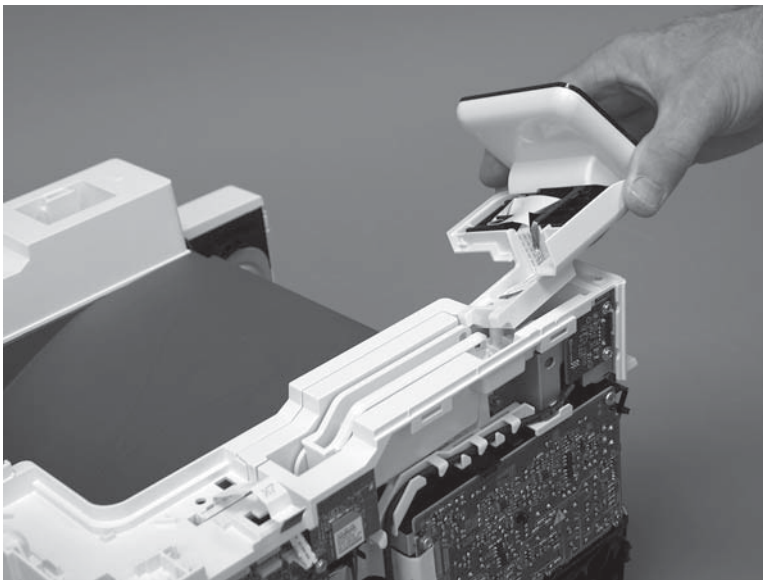

8. Lift up the control-panel FFC cover to remove the control-panel assembly.

Figure 1-1146 Remove the control-panel assembly

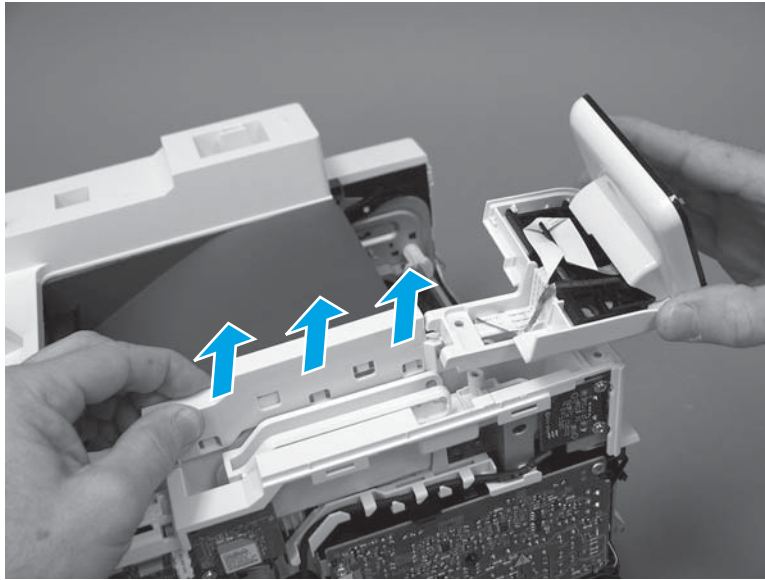

Step 7: Remove the top cover (M427/M426)

 **NOTE:** The step is for the M427/M426 printer. For the M403/M402, skip this step and go to [Step 9: Remove the top cover \(M403/M402\)](#) on page 627.

1. Release the USB cable (callout 1) from the cable guide.

Figure 1-1147 Remove the USB cable

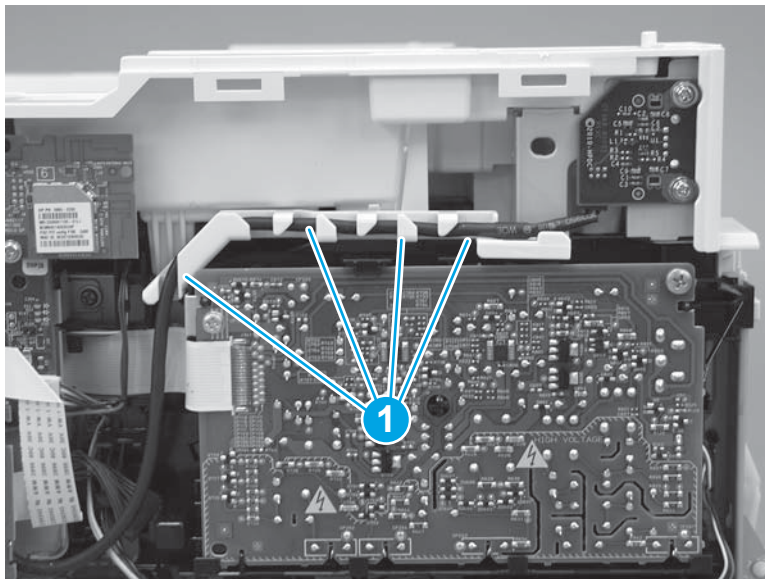

2. Remove five screws (callout 1), release four bosses (callout 2), and then remove the top cover (callout 3).

Figure 1-1148 Remove the cover

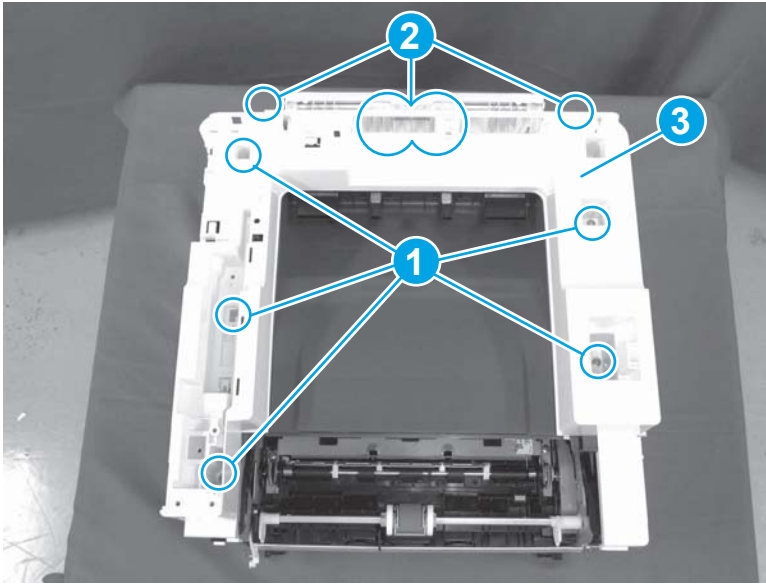

Step 8: Remove the NFC PCA cover (M427/M426)

 **NOTE:** The step is for the M427/M426 printer. For the M403/M402, skip this step and go to [Step 9: Remove the top cover \(M403/M402\) on page 627](#).

- ▲ Carefully pull up on the NFC cover (callout 1) to remove it.

 **CAUTION:** Do not damage the NFC PCA when removing the cover.

Figure 1-1149 Remove the cover

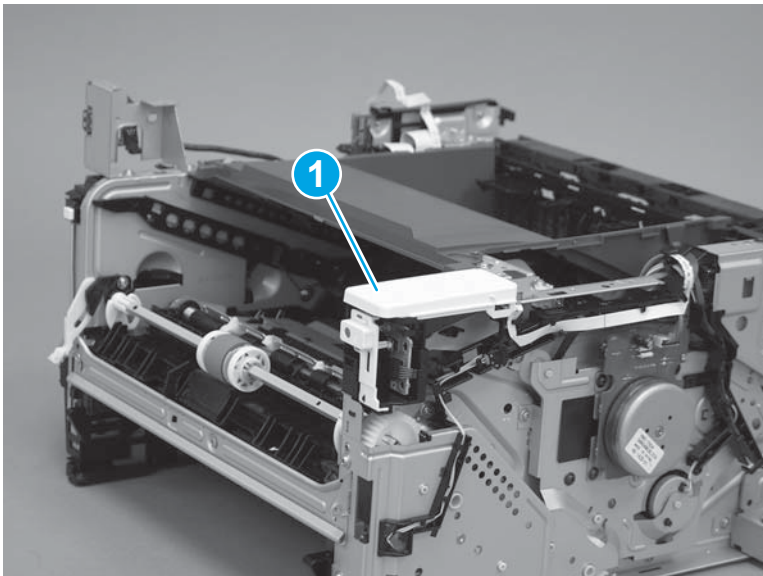

Step 9: Remove the top cover (M403/M402)

 **NOTE:** The step is for the M403/M402 printer. For the M427/M426, skip this step and go to [Step 10: Remove the paper delivery tray \(output bin\) on page 628](#).

1. Remove one screw (callout 1).

Figure 1-1150 Remove one screw



2. At the right side of the printer, release the one boss (callout 1), and then release one tab (callout 2).

Figure 1-1151 Release one boss and one tab

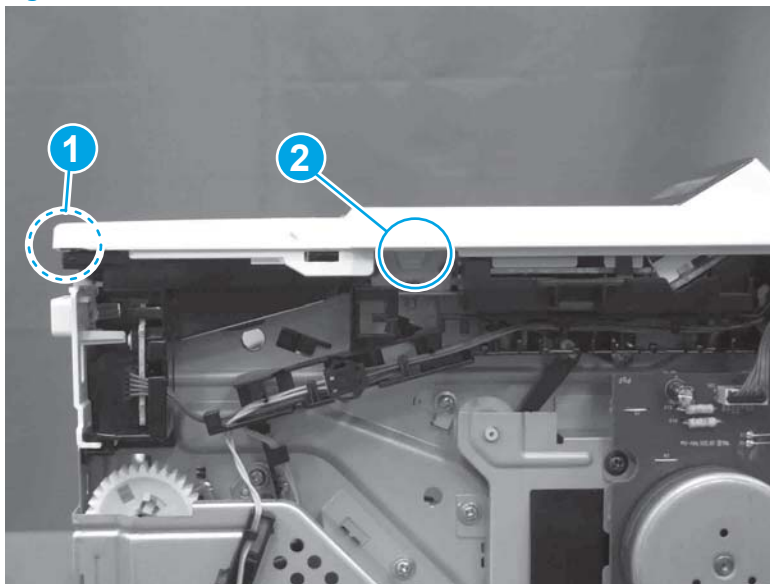

3. Release four tabs (callout 1), release four bosses (callout 2), and then remove the top cover (callout 3).



 **TIP:** Open the rear door to make releasing the bosses (callout 3) easier.

Figure 1-1152 Remove the cover

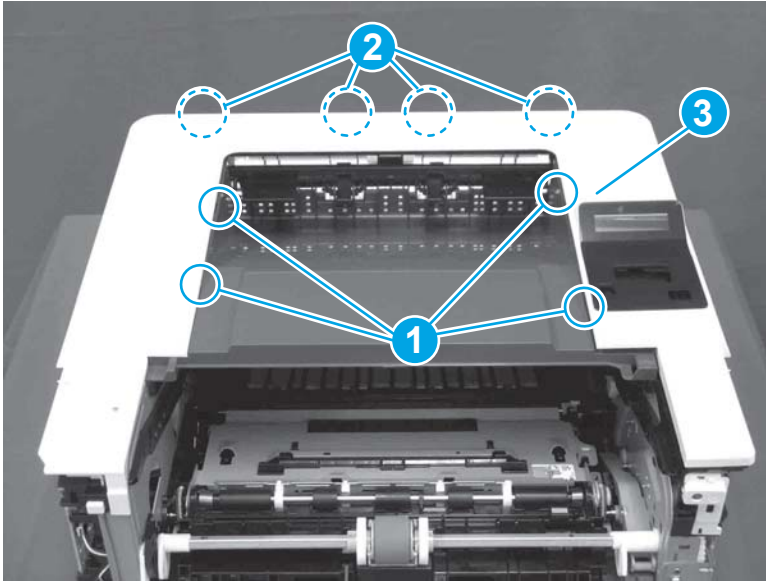

Step 10: Remove the paper delivery tray (output bin)

 **NOTE:** This procedure shows the M403/M402 model, however, the paper delivery tray (output bin) removal is similar for the M427/M426 printer.

- ▲ Release two bosses (callout 1), release two tabs (callout 2), and then remove the paper delivery tray (output bin; callout 3).

Figure 1-1153 Release two tabs

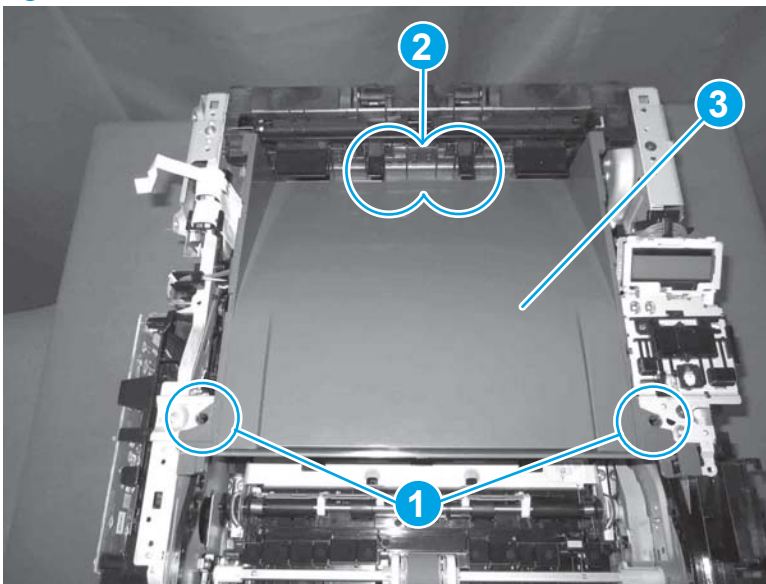

Step 11: Remove the NFC PCA

1. Remove one screw (callout 1).

Figure 1-1154 Remove one screw

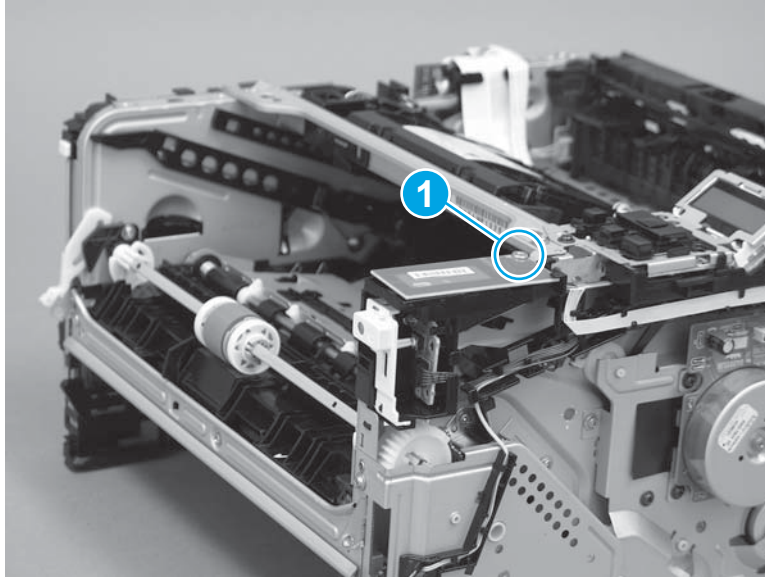

2. Turn the NFC PCA over to access the bottom side, disconnect one FFC (callout 1), and then remove the NFC PCA.

Figure 1-1155 Remove the NFC PCA

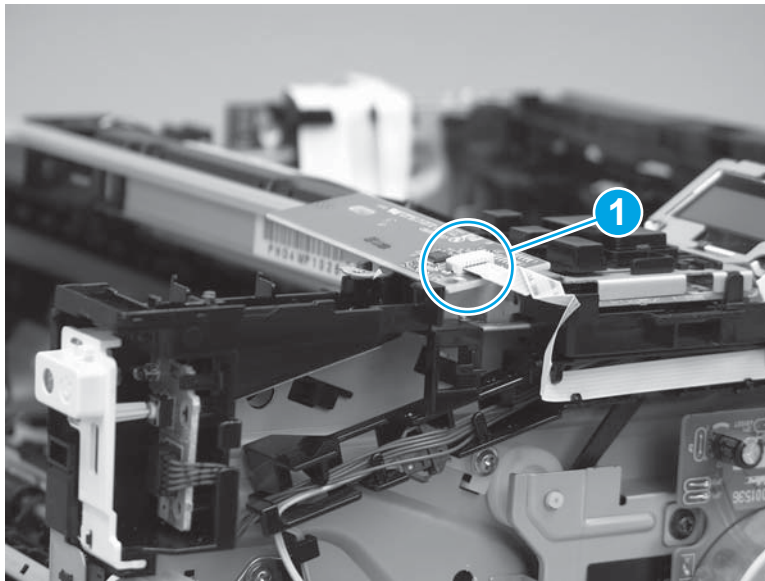

Step 12: Remove the NFC FFC

 **NOTE:** The M403/M402 product is shown in this procedure. However, the procedure is valid for the M427/M426 connecting PCA.

1. Release the FFC from the guide (callout 1).

Figure 1-1156 Release the FFC from the guide

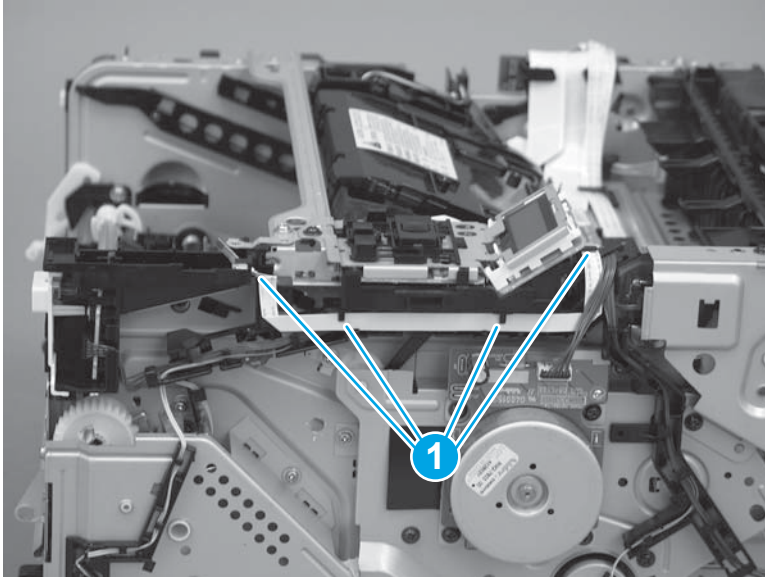

2. Release the FFC from the guide (callout 1).



NOTE: M403/M402 only: The control-panel FFC might need to be moved out of the way to gain access to the NFC FFC.

Figure 1-1157 Release the FFC from the guide

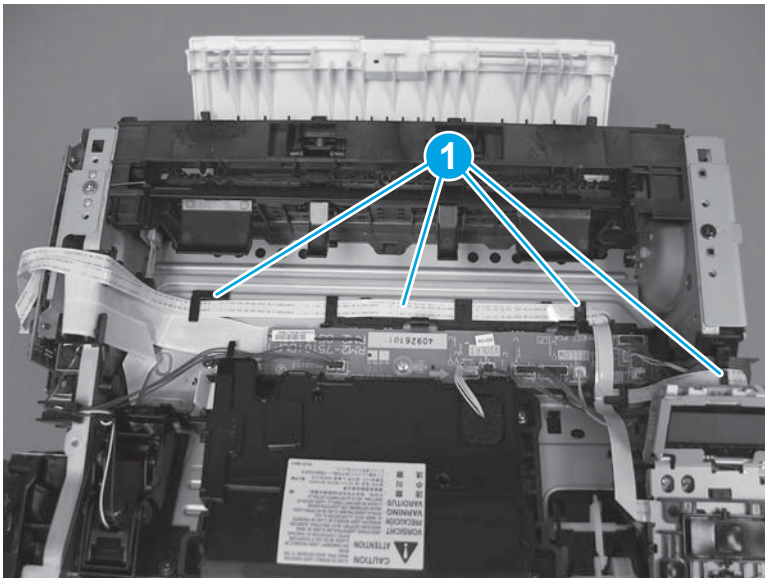

3. Disconnect one FFC (callout 1), and then remove the FFC.

Figure 1-1158 Disconnect and remove the FFC

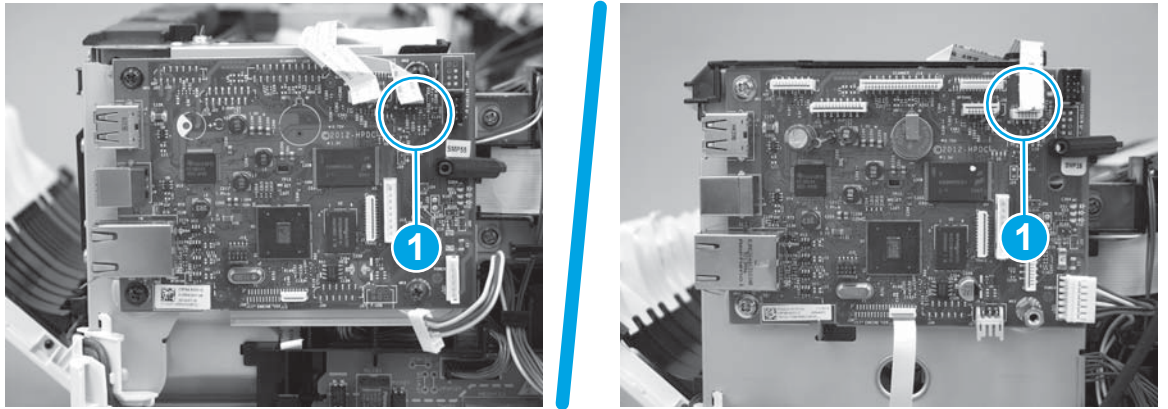

Step 13: Unpack the replacement assembly

Unpack the replacement part from the packaging.

<http://www8.hp.com/us/en/hp-information/environment/product-recycling.html>

 **NOTE:** HP recommends responsible disposal of the defective part.

Figure 1-1159 Recycle and unpack

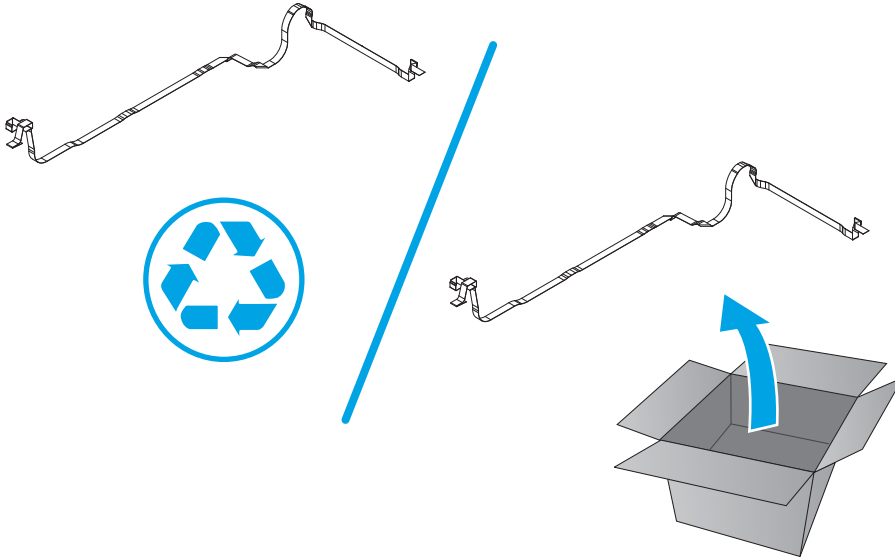

Step 14: Install the NFC FFC

 **NOTE:** The M403/M402 product is shown in this procedure. However, the procedure is valid for the M427/M426 connecting PCA.

1. Connect one FFC (callout 1) to the formatter PCA.

Figure 1-1160 Connect the FFC

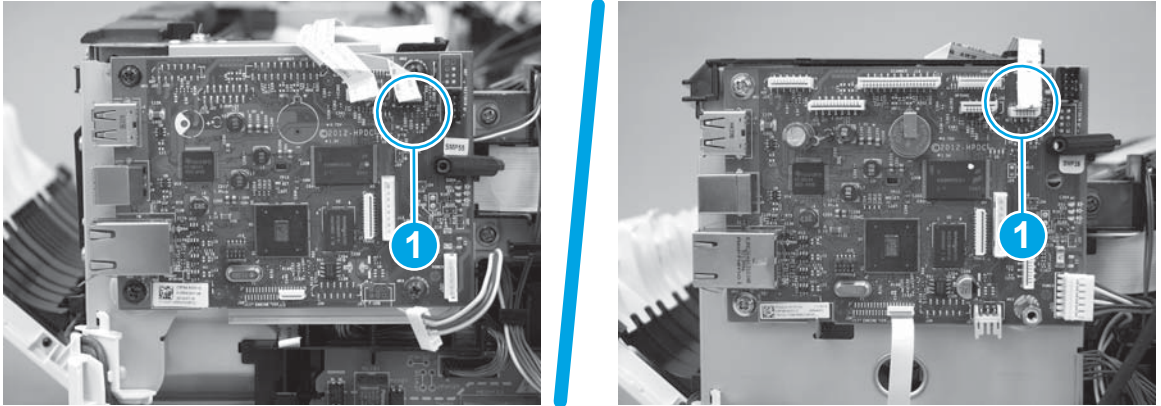

2. Install the NFC FFC in the guide (callout 1).

 **NOTE:** **M403/M402 only:** The control-panel FFC might need to be moved out of the way to gain access to the guide.

Figure 1-1161 Install the FFC in the guide

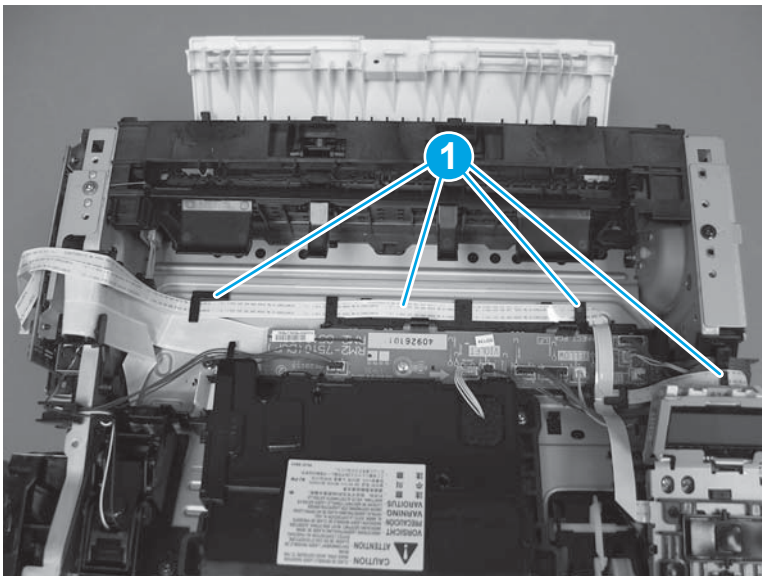

3. Install the FFC in the guide (callout 1).

Figure 1-1162 Install the FFC in the guide

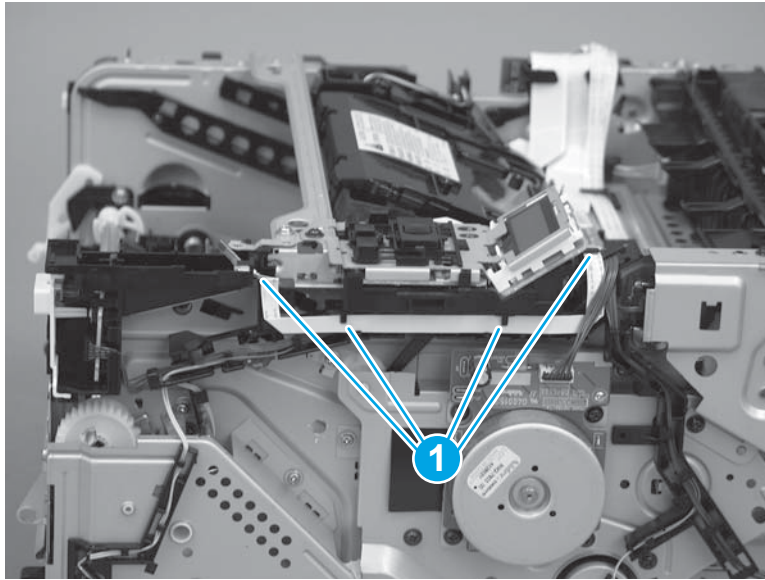

Step 15: Install the NFC PCA

1. Connect one FFC (callout 1).

Figure 1-1163 Connect one FFC

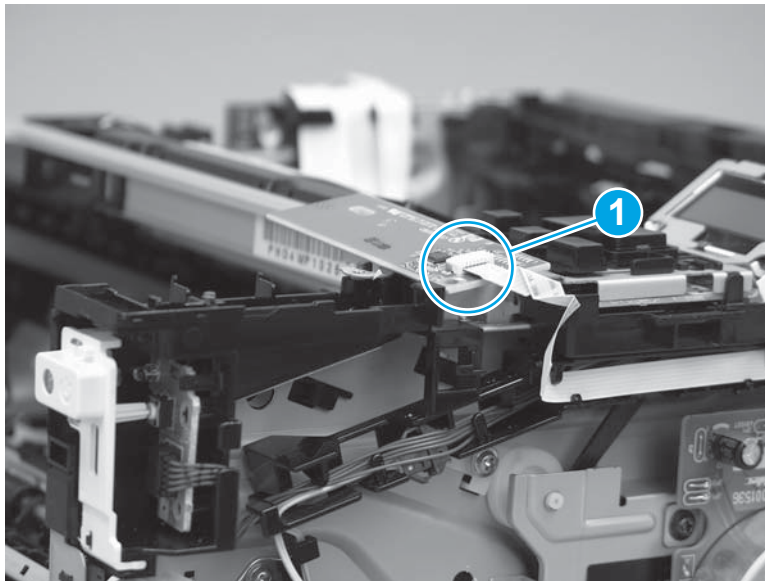

2. Position the NFC PCA on the holder.

CAUTION: Make sure that the NFC PCA is correctly positioned on the holder. One corner (callout 1) is under a tab on the holder, and the alignment pins on the holder fit in the hole and slot in the PCA (callout 2).

To avoid damage to the PCA, it must be installed flat on the holder **before** installing the mounting screw.

Figure 1-1164 Install the NFC PCA

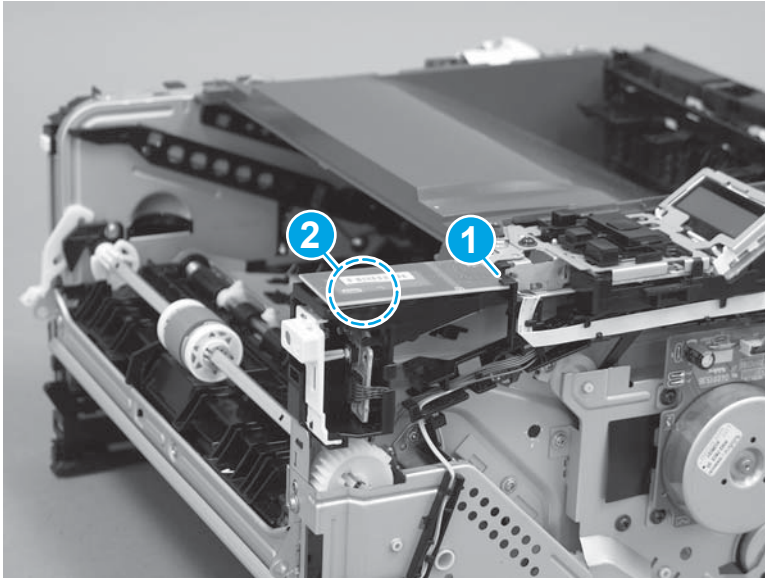

3. Install one screw (callout 1).

Figure 1-1165 Install one screw

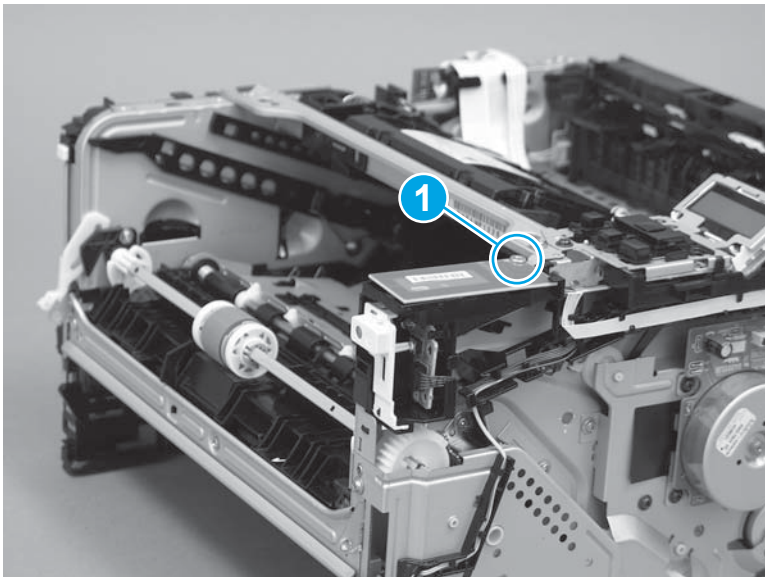

Step 16: Install the paper delivery tray (output bin)

 **NOTE:** This procedure shows the M403/M402 model, however, the paper delivery tray (output bin) removal is similar for the M427/M426 printer.

- ▲ Position the remove the paper delivery tray (output bin; callout 1) on the printer, engage two tabs (callout 2), and then engage two bosses (callout 3).

Figure 1-1166 Engage two tabs

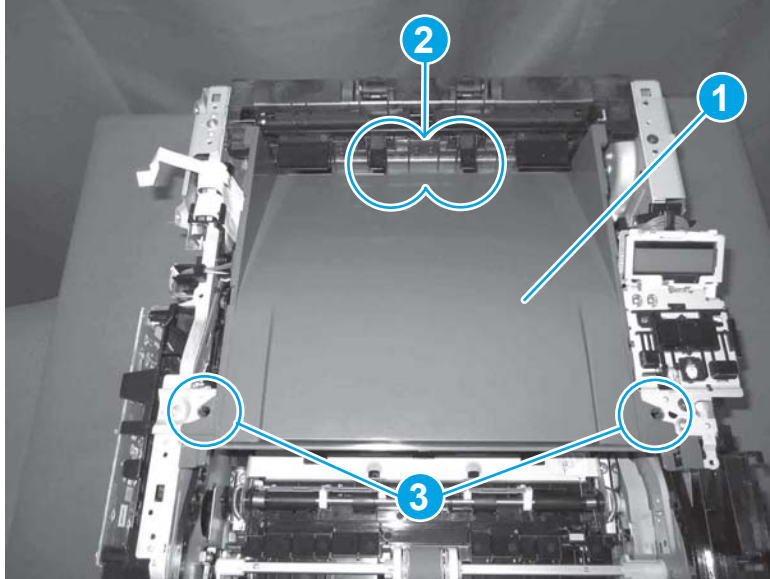

Step 17: Install the top cover (M403/M402)

 **NOTE:** The step is for the M403/M402 printer. For the M427/M426, skip this step and go to [Step 18: Install the NFC PCA cover \(M427/M426\) on page 637](#).

1. Position the rear edge of the cover on the printer.

Figure 1-1167 Install the cover

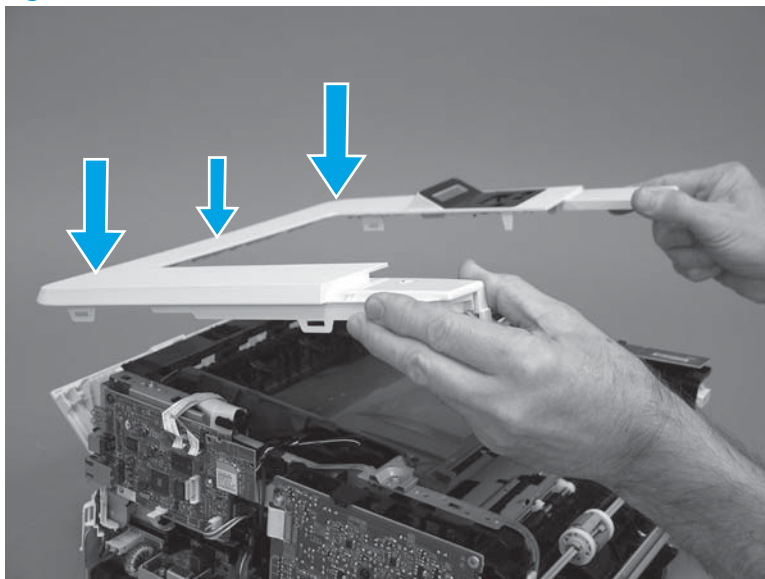

2. Engage four bosses (callout 1), rotate the front of the cover down (callout 2) and onto from the printer, and then engage four tabs (callout 3).

Figure 1-1168 Engage four bosses and tabs

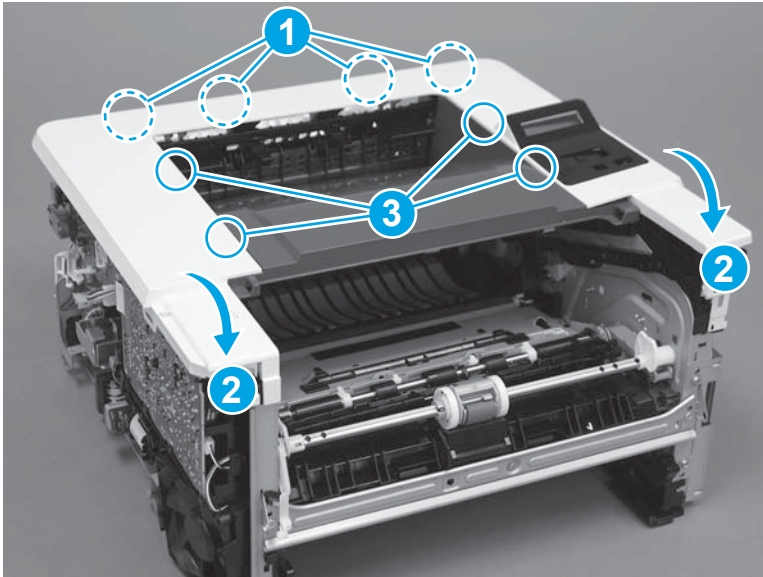

3. At the right side of the printer, engage the one boss and one tab (callout 1).

Figure 1-1169 Engage one boss and one tab

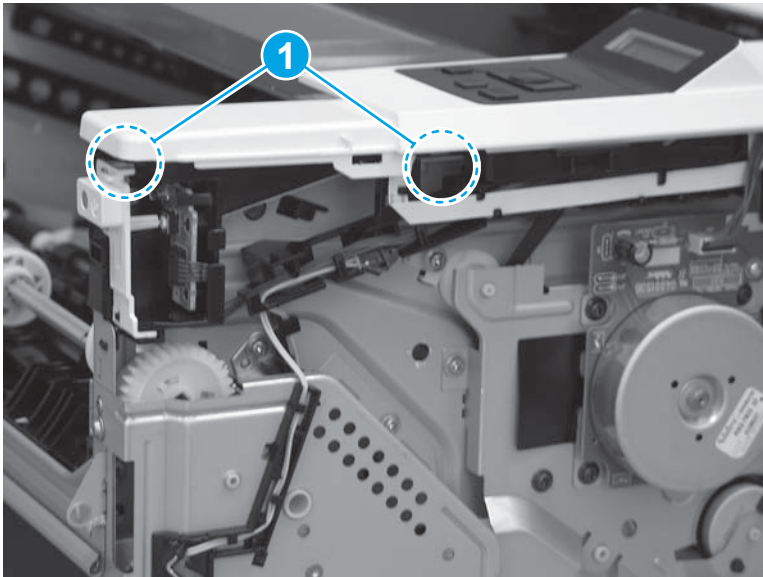

4. Install one screw (callout 1).

Figure 1-1170 Install one screw

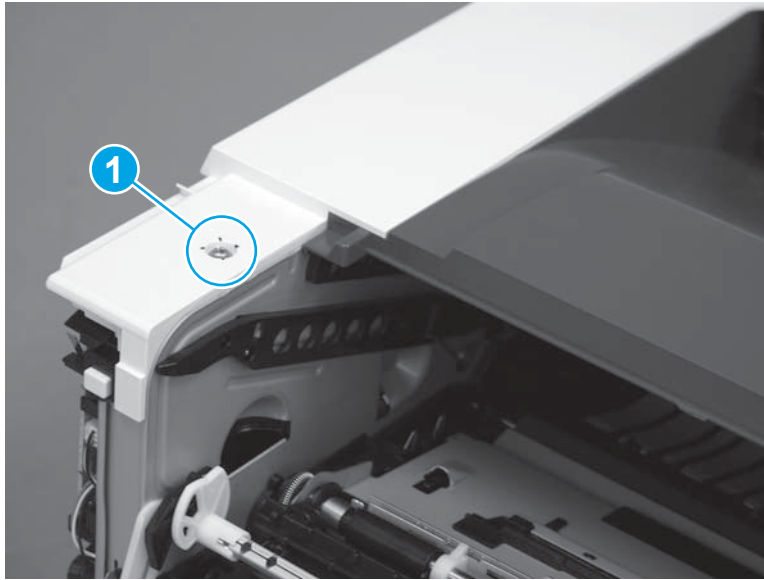

Step 18: Install the NFC PCA cover (M427/M426)

 **NOTE:** The step is for the (M427/M426) printer. For the M403/M402, skip this step and go to [Step 22: Install the right cover on page 649](#).

- ▲ Carefully install the NFC cover on the printer.

 **CAUTION:** Do not damage the NFC PCA when installing the cover.

Figure 1-1171 Remove the cover

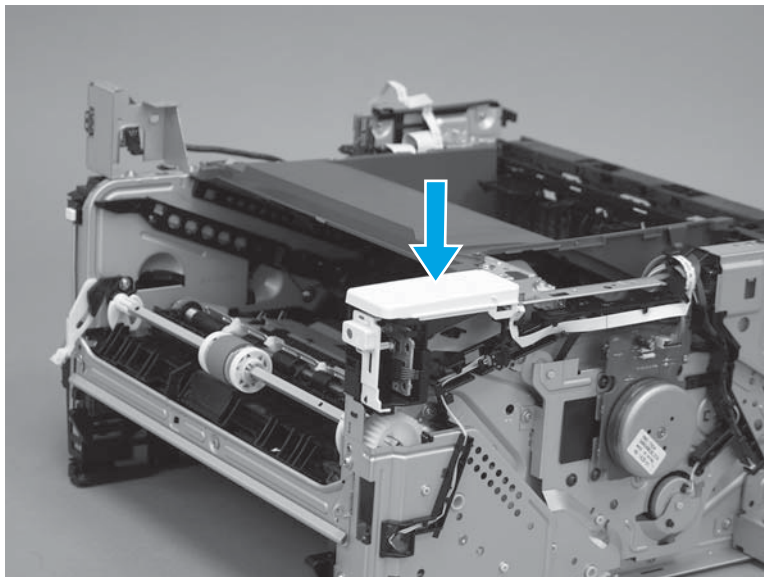

Step 19: Install the top cover (M427/M426)

 **NOTE:** The step is for the M427/M426 printer. For the M403/M402, skip this step and go to [Step 22: Install the right cover on page 649](#).

1. Position the rear edge of the top cover on the printer.

Figure 1-1172 Install the cover

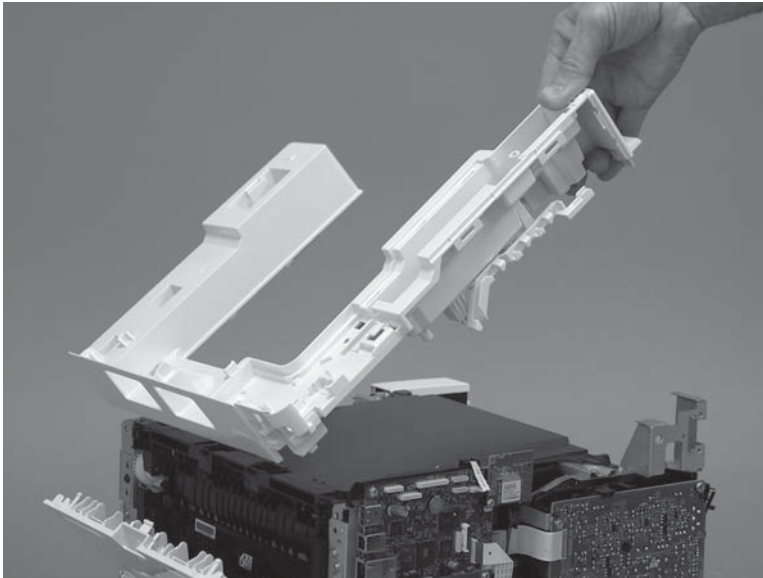

2. Engage four bosses (callout 1).

Figure 1-1173 Engage four bosses

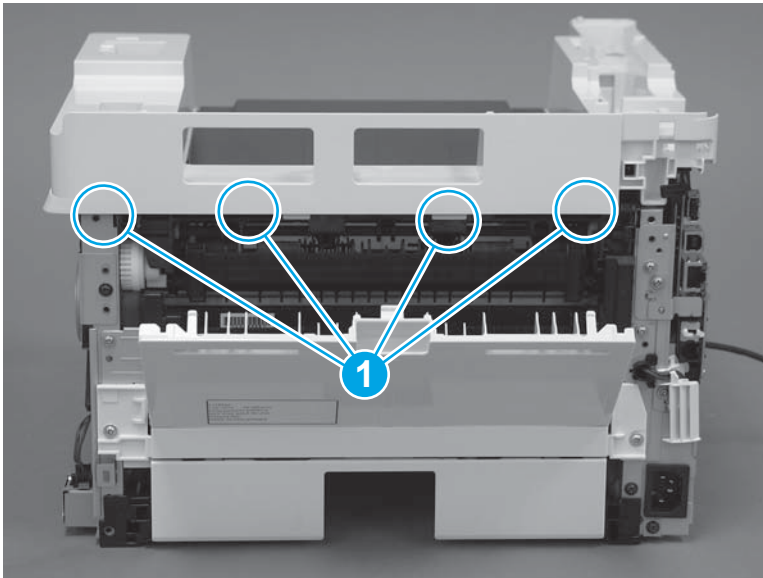

3. Rotate the front edge of the cover down.

Figure 1-1174 Rotate the front edge of the cover down

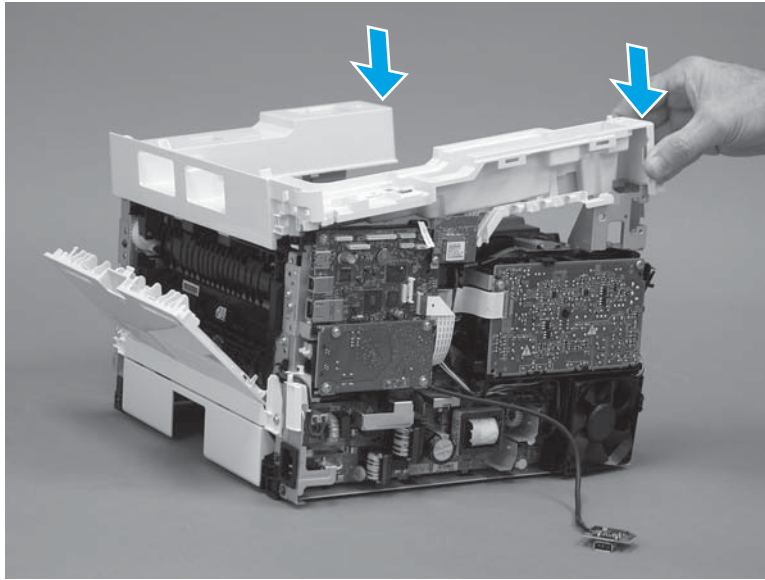

4. Install the USB cable (callout 1) in the guide.

Figure 1-1175 Install the USB PCA

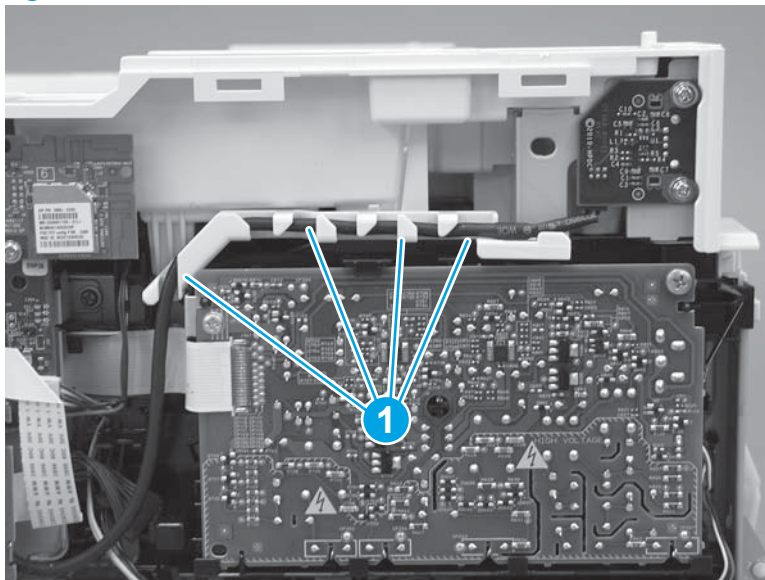

5. Install five screws (callout 1).

Figure 1-1176 Install five screws

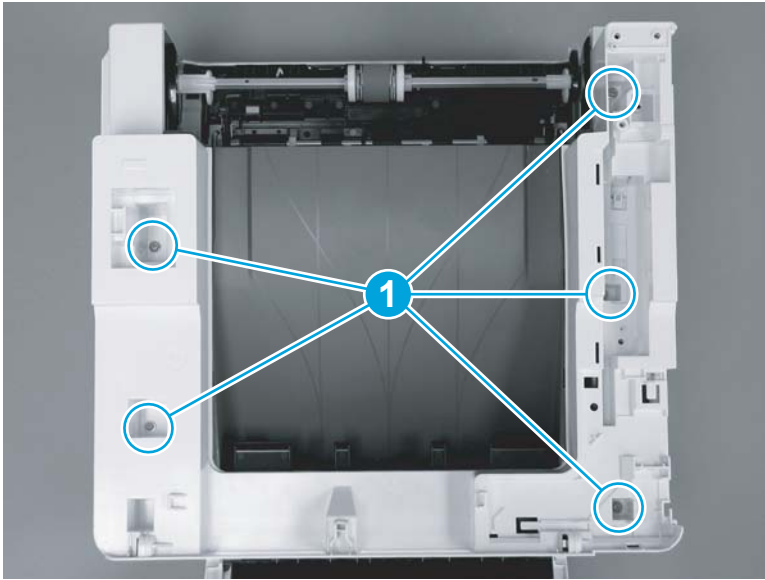

Step 20: Install the control panel (M427/M246)

 **NOTE:** The step is for the M427/M426 printer. For the M403/M402, skip this step and go to [Step 22: Install the right cover on page 649](#).

1. Slide the control-panel FFC cover into the slot in the top cover (next to the document feeder support arm) to install it.

Figure 1-1177 Install the control-panel FFC cover

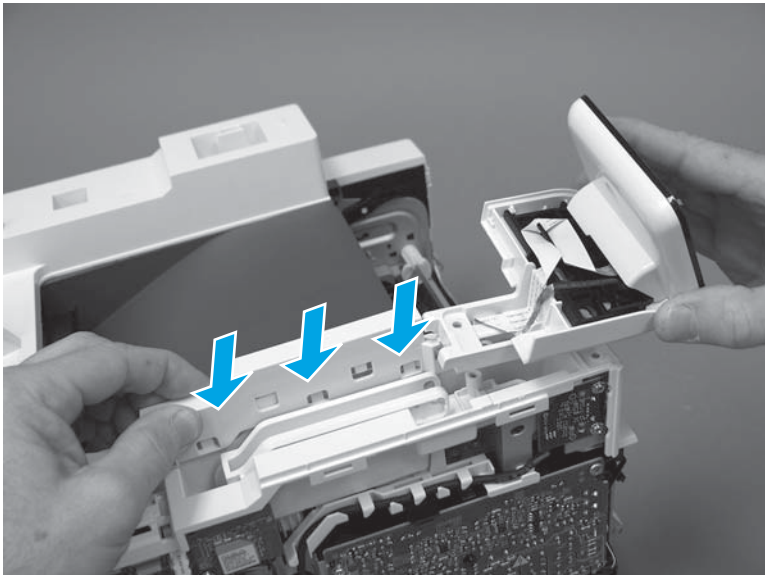

2. Install the control-panel assembly on the top cover.

Figure 1-1178 Install the control-panel assembly

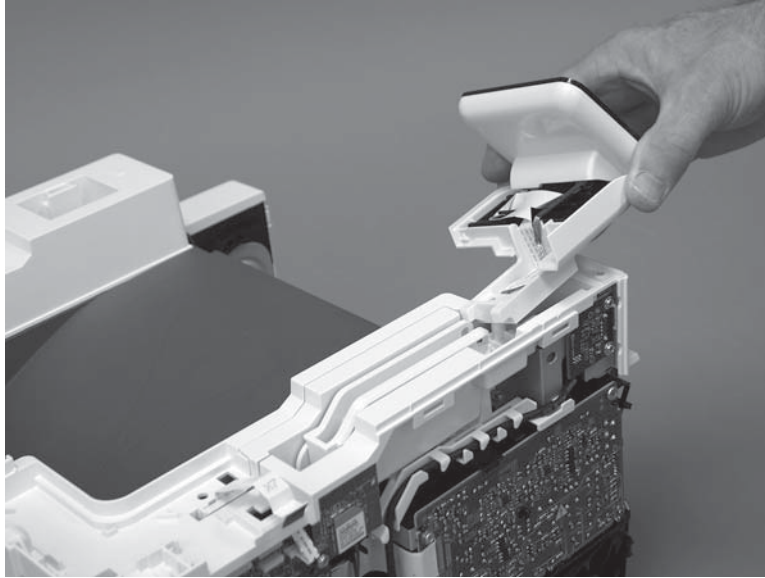

3. Move the FFC out of the way, and then install two screws (callout 1).

Figure 1-1179 Install two screws

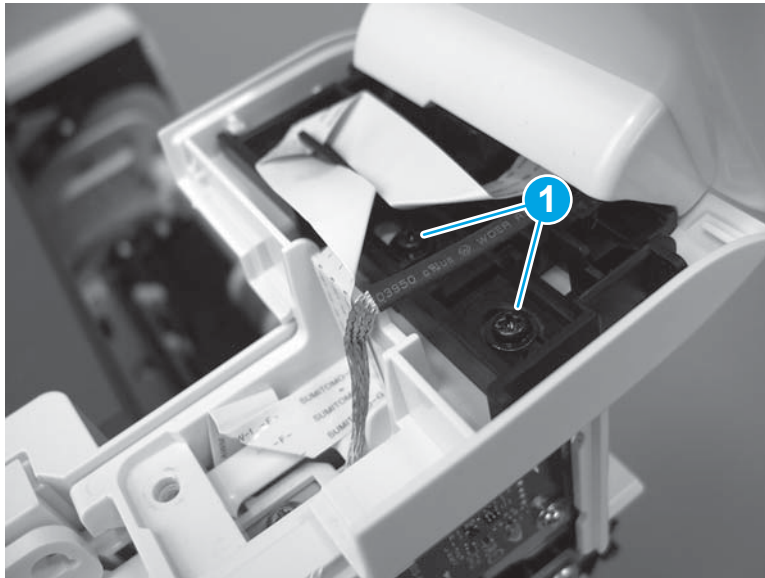

4. Install one grounding screw (callout 1), and then make sure that the ground cable (callout 2) is properly routed.

Figure 1-1180 Remove one screw

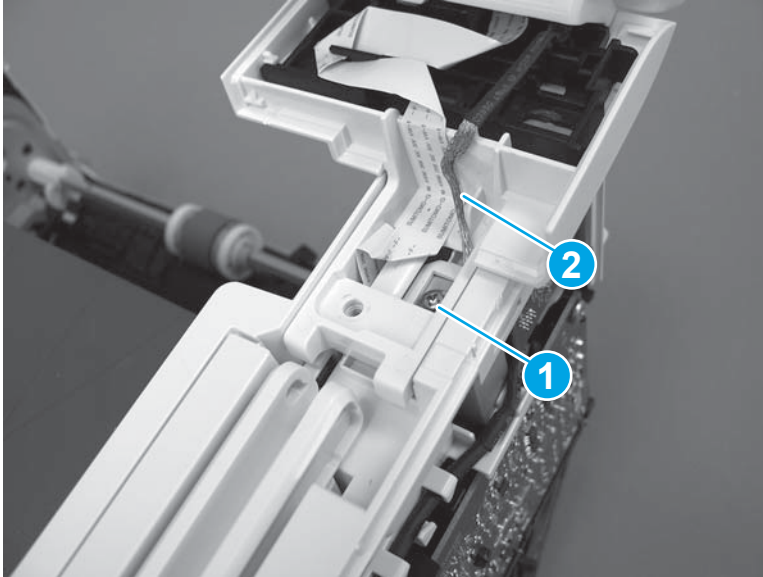

5. Install the control-panel cable cover.

Figure 1-1181 Install the cover

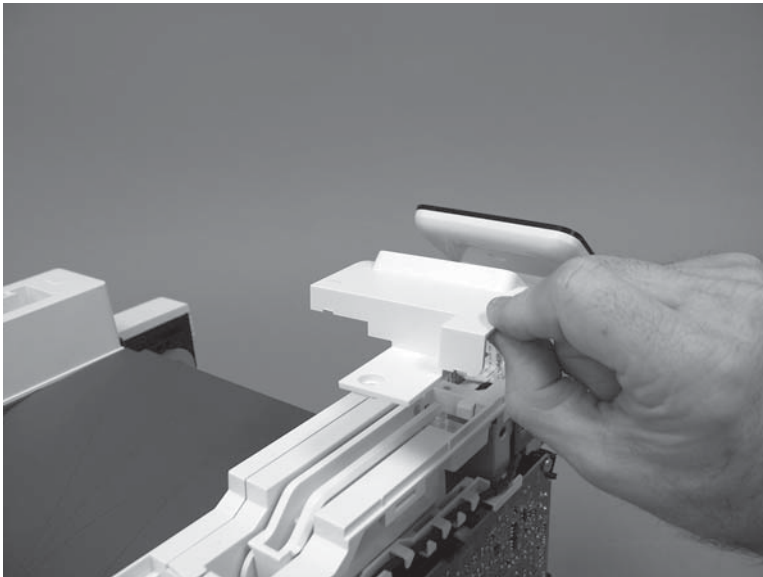

6. Make sure that the two tabs (callout 1) on the cover snap into place.

Figure 1-1182 Engage two tabs

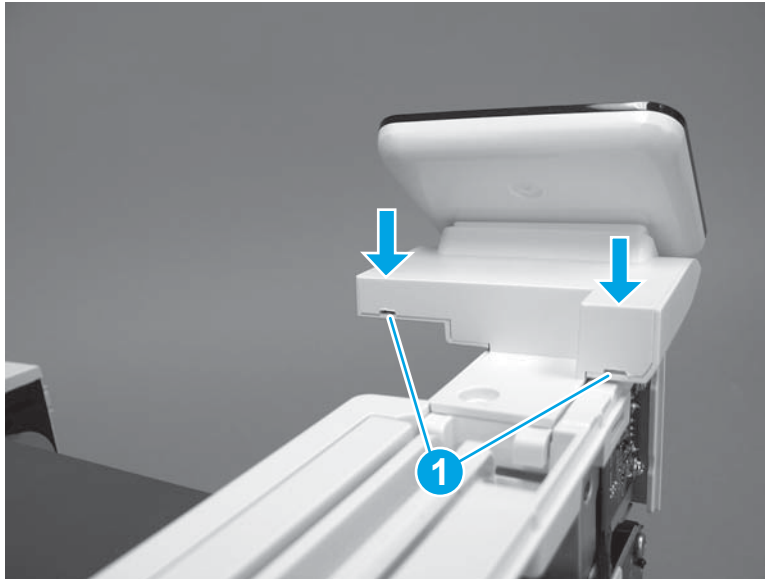

7. Install one screw (callout 1).

Figure 1-1183 Install one screw

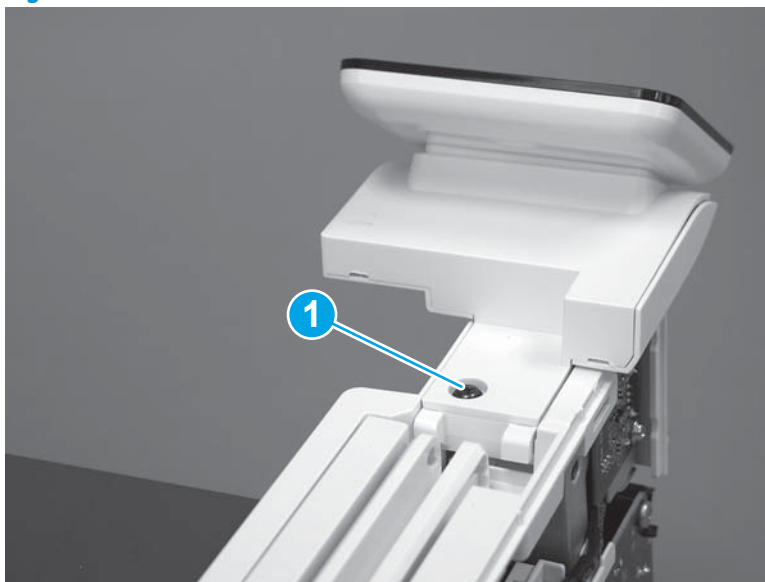

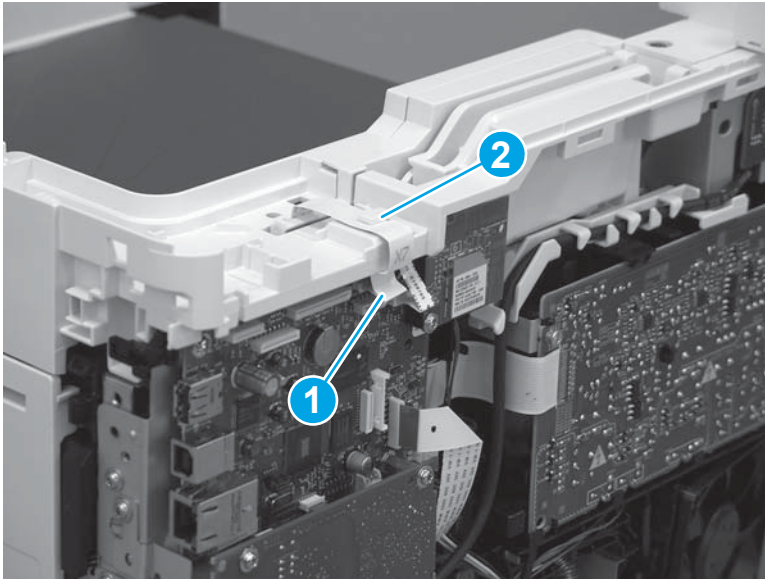

8. Install the FFC in the retainer (callout 1), and then connect one FFC (callout 1; J114).

Figure 1-1184 Connect one connector



Step 21: Install the integrated scanner assembly (M427/M246)

 **NOTE:** The step is for the M427/M426 printer. For the M403/M402, skip this step and go to [Step 22: Install the right cover on page 649](#).

 **NOTE:** M427/M426 models only. The integrated scanner assembly (ISA) includes the sub-scanner assembly (SSA) and the automatic document feeder (ADF).

1. Position the ISA on the printer.

Figure 1-1185 Position the ISA on the printer

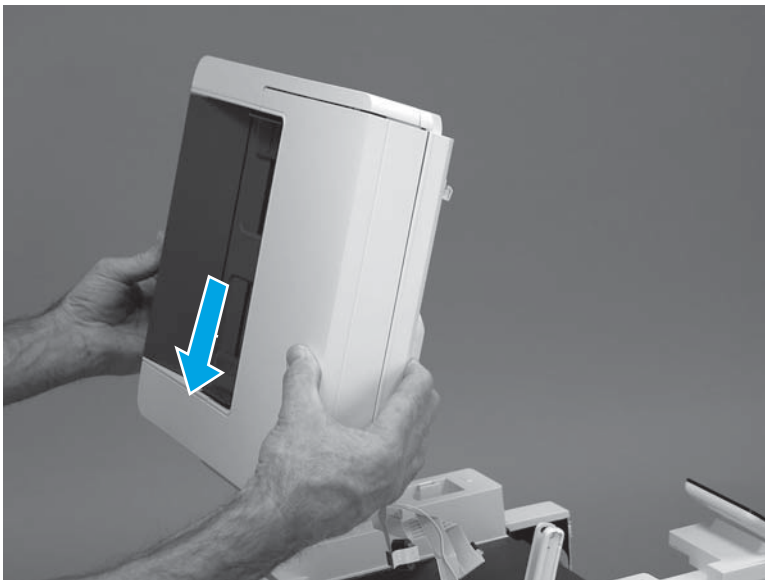

2. Engage the hinge pins on the ISA with the holders in the top cover (callouts 1/2), and then slide the ISA as shown to engage them

Figure 1-1186 Engage the hinge pins with the holders

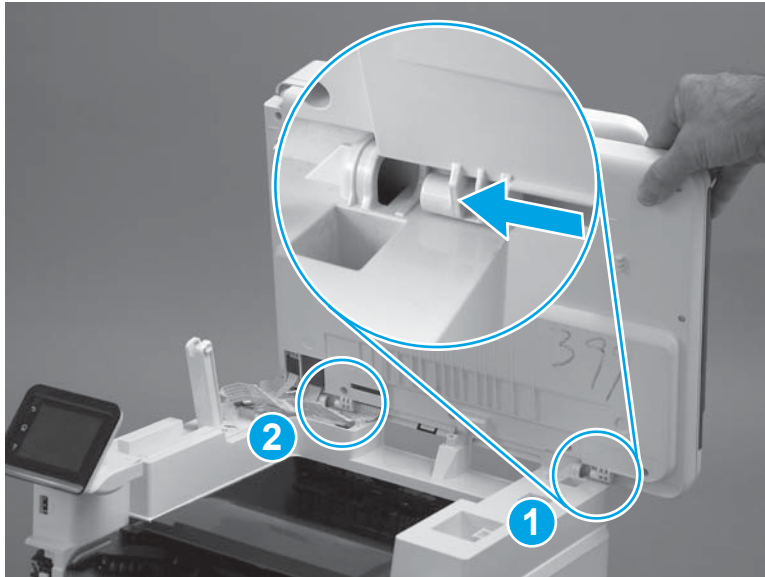

3. Rotate the ISA towards the front of the printer until it rests on the ISA lift assembly (callout 1).

Figure 1-1187 Rotate the ISA towards the front of the printer



4. Pass the ground wire through the opening in the top cover.

Figure 1-1188 Pass the wire through the opening

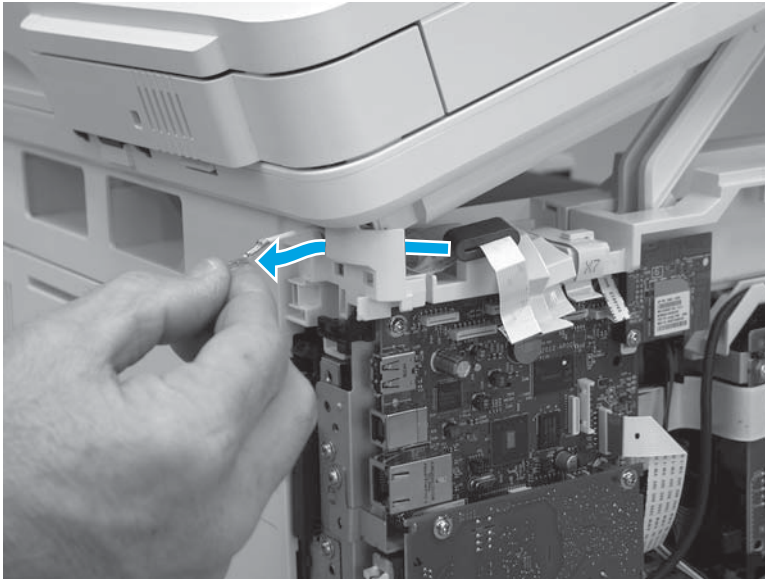

5. Install one screw (callout 1).

Figure 1-1189 Install one screw

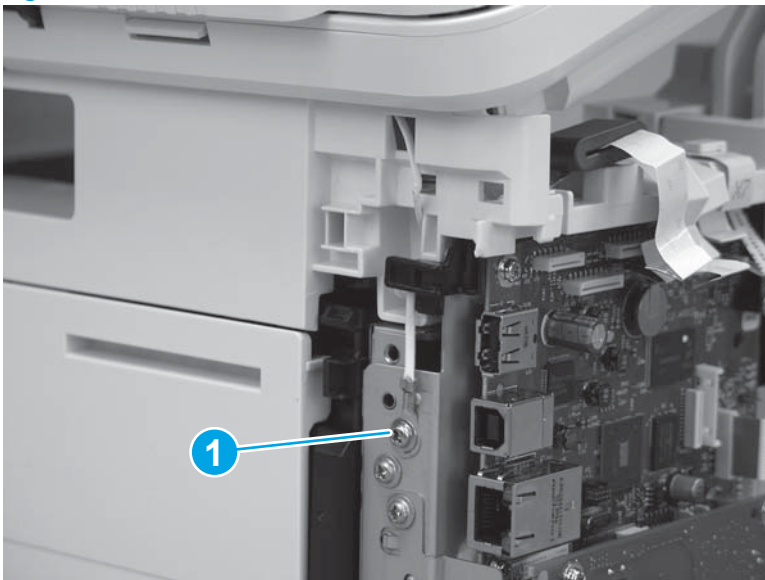

6. Install the ISA lift assembly slider pin.

 **Reinstallation tip:** Align the keyed portion of the locking pin with the slot and hole in the support arm.

Figure 1-1190 Install the slider pin



7. Rotate the slider pin (callout 1) towards the rear of the printer until the tab (callout 2) snap into place.

Figure 1-1191 Secure the slider pin

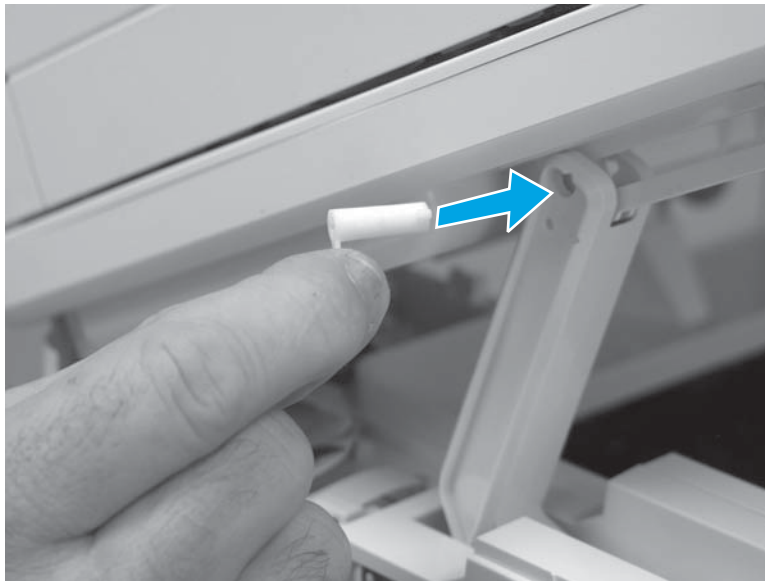
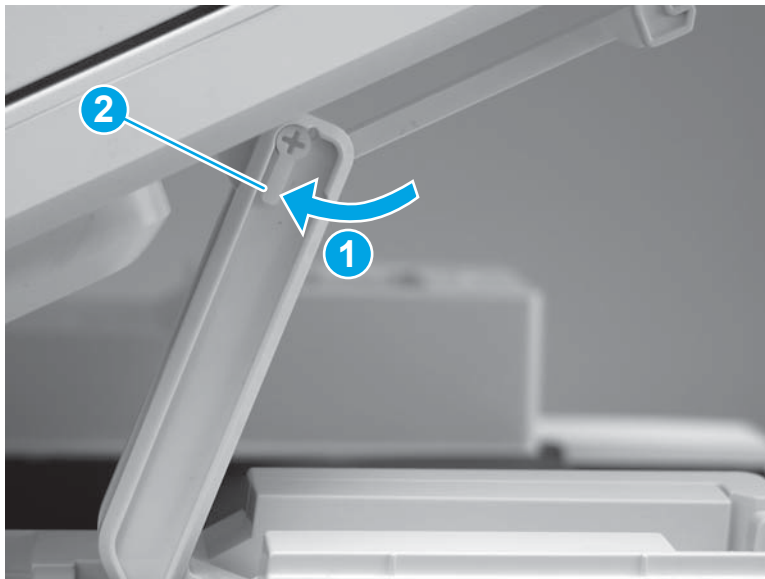

8. Install the ferrite (callout 1) in the holder, and then connect three FFCs (callout 2).

Figure 1-1192 Connect three FFCs

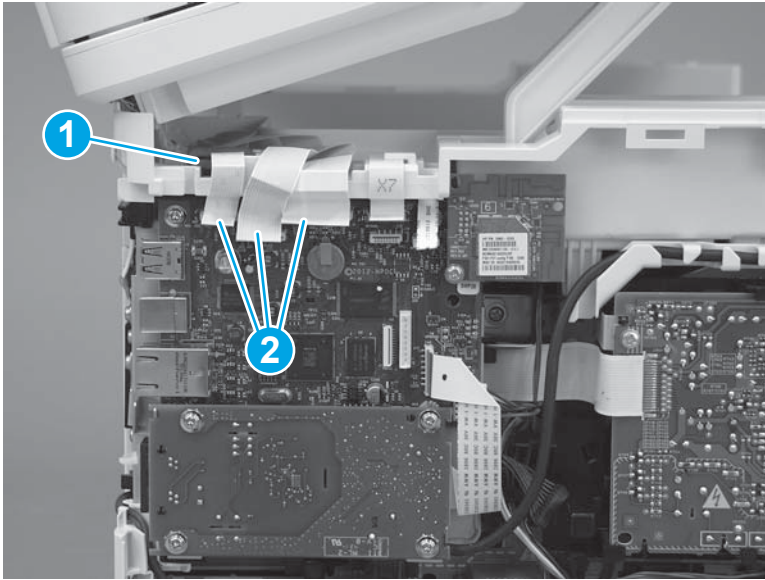

9. Position the rear edge of the ISA flat-flexible cable (FFC) cover on the printer (callout 1), and then rotate it down (callout 2) until it snaps into place.

Figure 1-1193 Install the ISA FFC cover

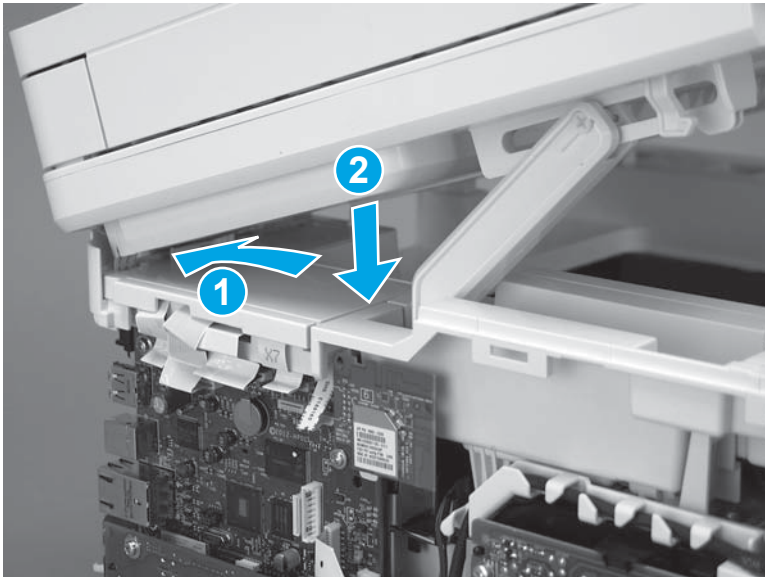

10. Lower the ISA.

Figure 1-1194 Lower the ISA

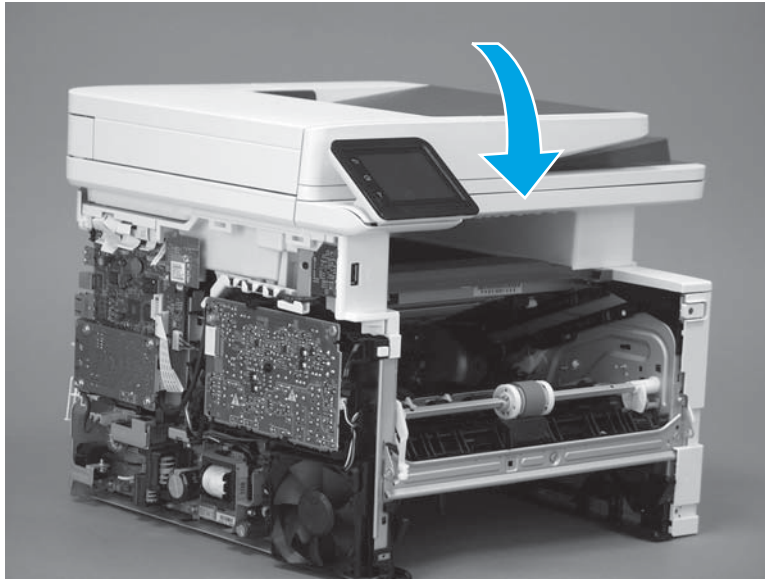

Step 22: Install the right cover

1. Position the cover (callout 1) on the printer, and then engage two bosses (callout 2).

Figure 1-1195 Install the cover

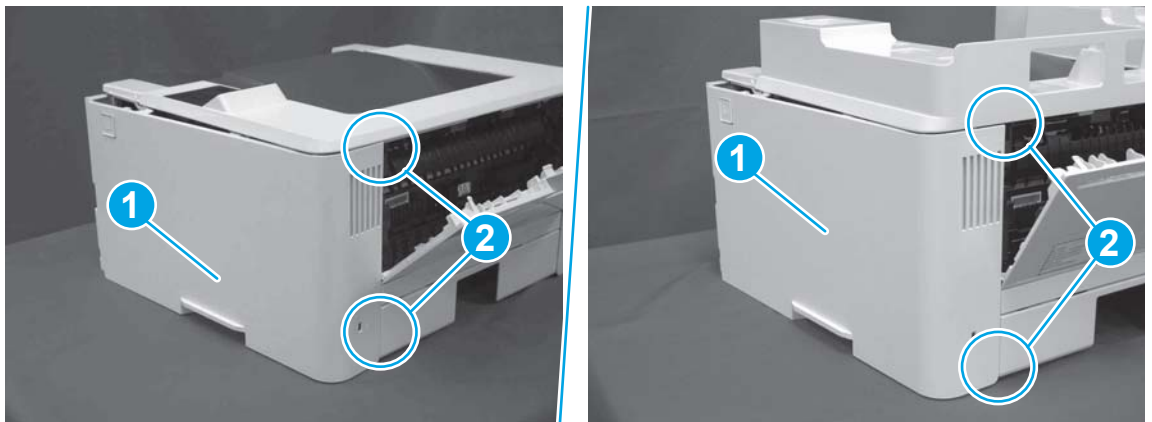

2. Rotate the front of the cover onto the printer (callout 1), engage three (callout 2) tabs, and then engage two bosses (callout 3).

Figure 1-1196 Engage two bosses and one tab

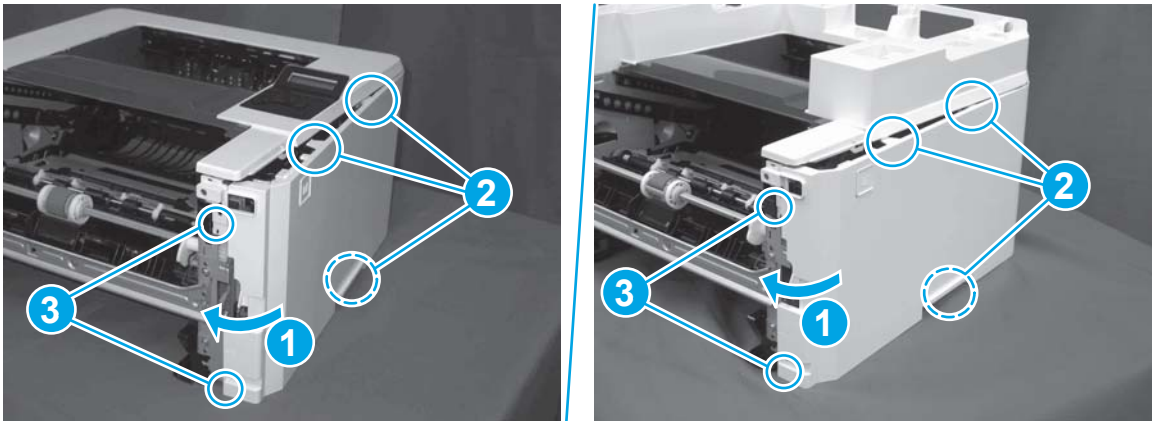

3. Make sure that the power switch (callout 1) and cartridge door assembly button (callout 2) correctly function.



NOTE: Remove, and then reinstall the cover if the switch or button does not correctly function.

Figure 1-1197 Check the power switch and cartridge door assembly button

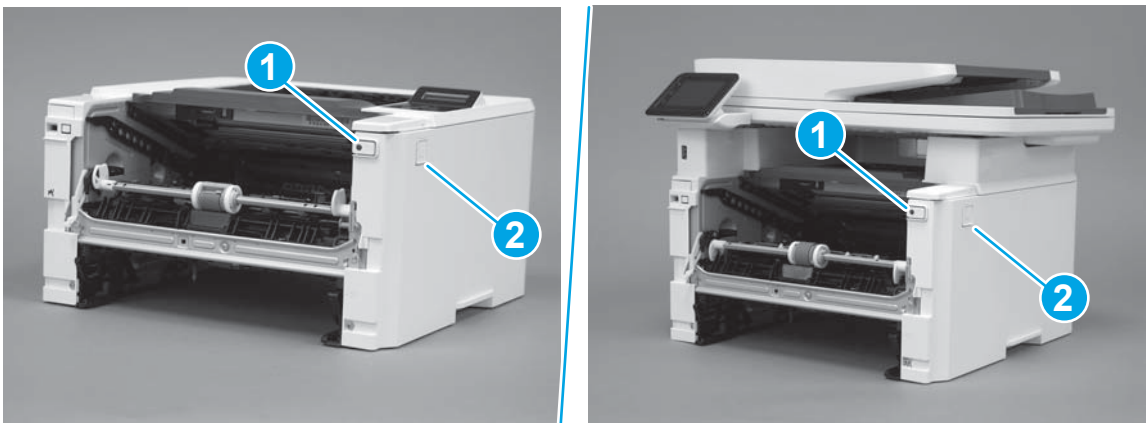

4. Install one screw (callout 1).

Figure 1-1198 Install one screw



Step 23: Install the left cover

1. At the front of the printer, do one of the following:
 - **M403/M402:** Position the cover on the printer (callout 1), and then engage two bosses (callout 2).
 - **M427/M426:** Position the cover on the printer (callout 3), engage one tab (callout 4), and then engage two bosses (callout 4).

Figure 1-1199 Install the cover

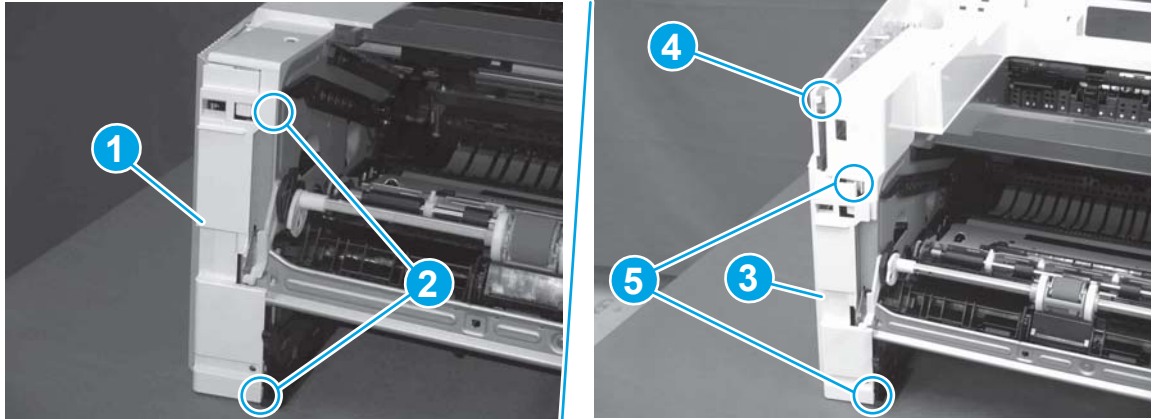

2. Carefully rotate the rear of the cover onto the printer (callout 1), engage three tabs (callout 2), and then engage two bosses (callout 3).

Figure 1-1200 Engage three tabs and two bosses

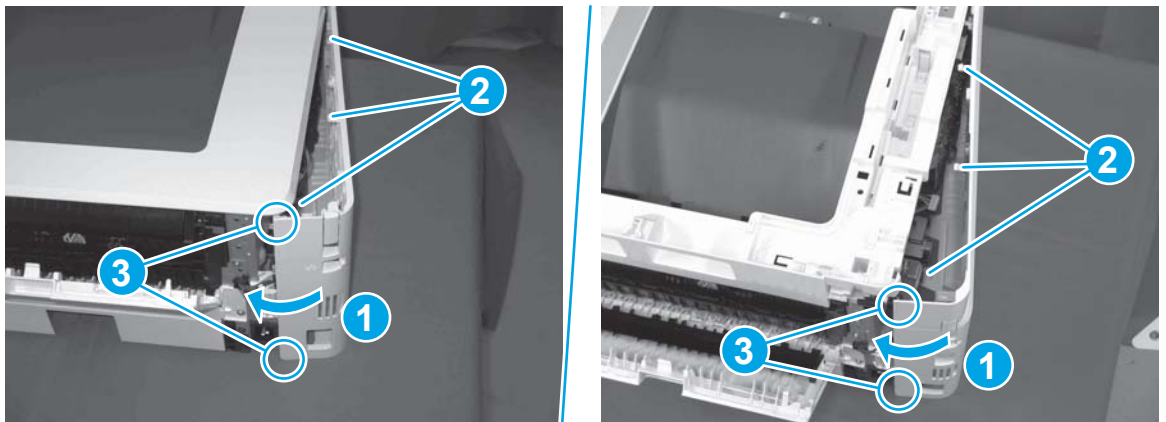

3. Install one screw (callout 1).

Figure 1-1201 Install one screw

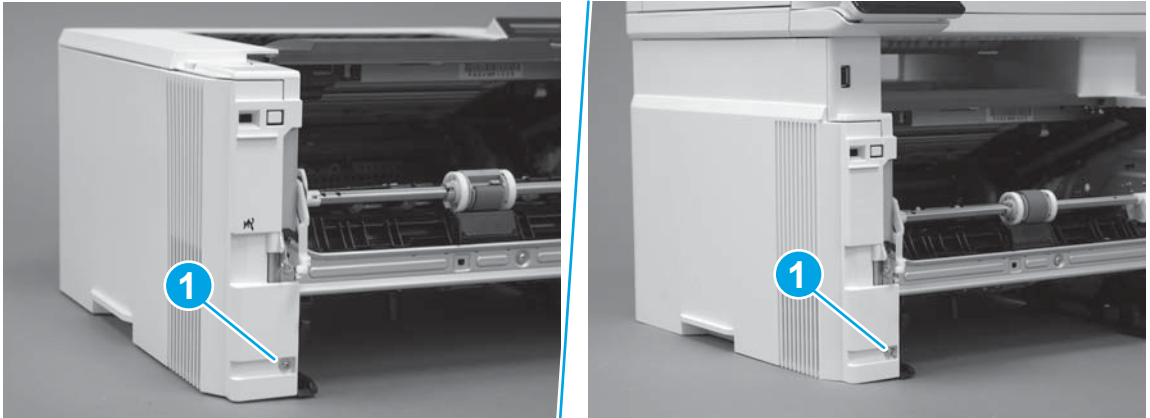

Step 24: Install the cartridge door assembly

 **Reinstallation tip:** After a replacement door is installed, make sure to install the nameplate (supplied in the kit) corresponding to the printer name on the door.

1. Position the door close to the printer, and then engage the keyed pin on the left-side retainer arm with the hole in the door.

Figure 1-1202 Engage the left-side retainer arm

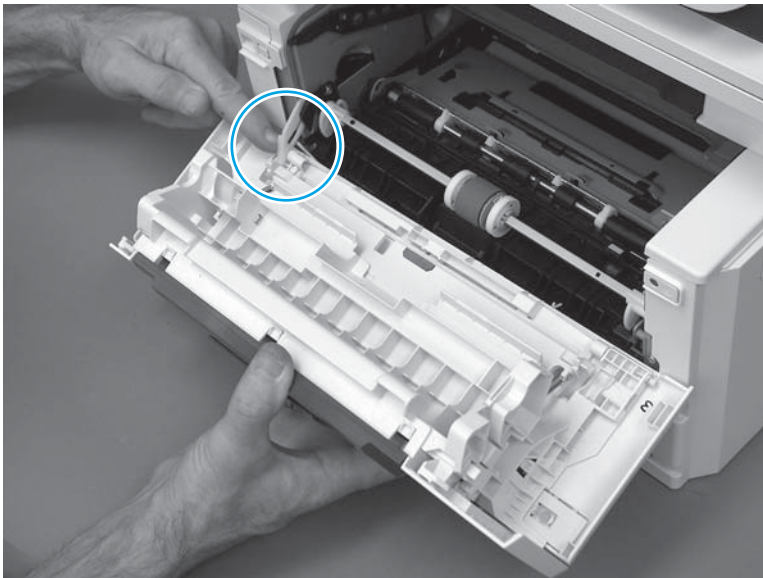

2. Engage the right-side door hinge pin with the hole in the chassis (callout 1).

Figure 1-1203 Install the door

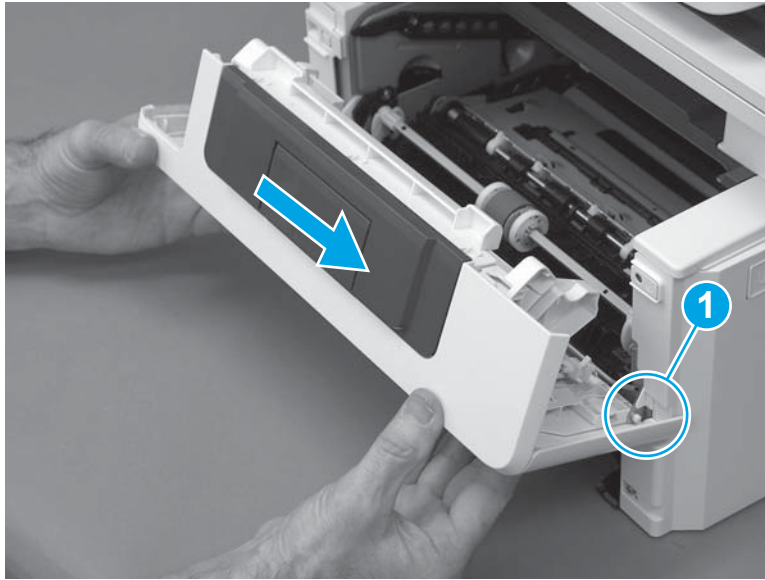

3. Install the link (callout 1).

 **IMPORTANT:** Make sure that the link snaps into place on the arm (callout 2). The link actuates the fuser pressure-release mechanism.

Figure 1-1204 Install the pressure-release link

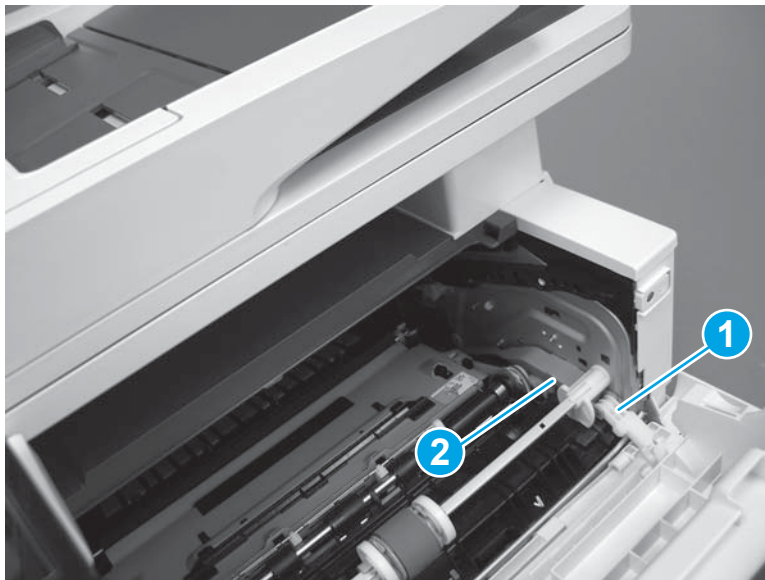

4. Slide the guide into the printer (callout 1), and then make sure that the tab (callout 2) snaps into place to secure the guide to the chassis.

Figure 1-1205 Install the guide

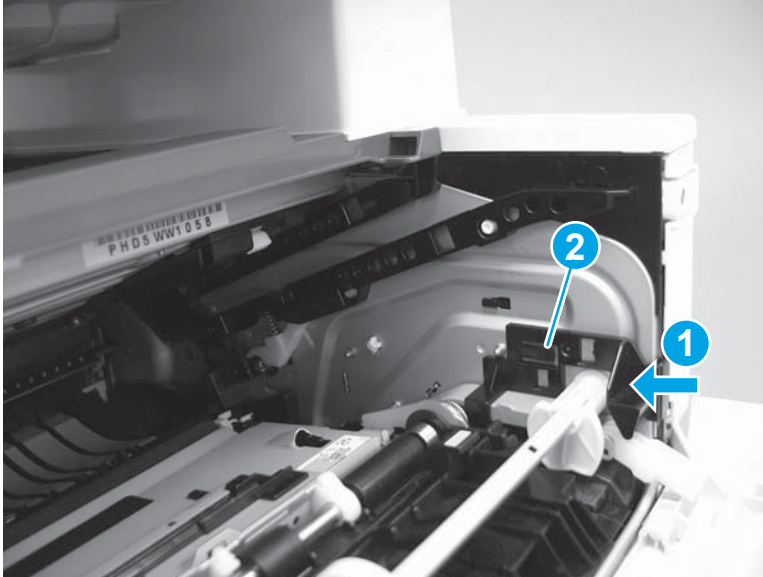

5. Position the shaft on the door, and then align the left-side hinge on the door with the hole in the chassis (callout 1).

Figure 1-1206 Align the hinge

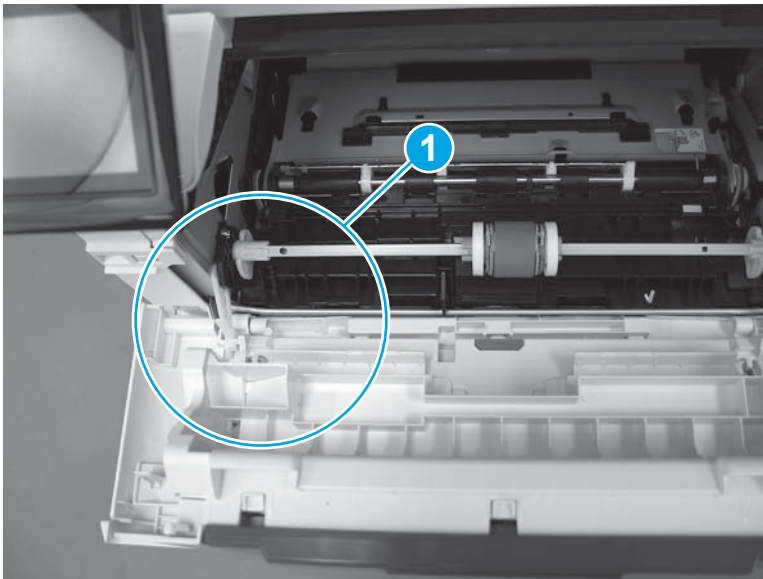

6. Push the shaft towards the left side of the printer to install it (callout 1).

 **Reinstallation tip:** Make sure that the support shaft is fully installed and correctly orientated (callout 2) so that it will not interfere with the door opening and closing.

Figure 1-1207 Install the support shaft



Step 25: Install Tray 2

- ▲ Slide the tray straight into the printer to install it.

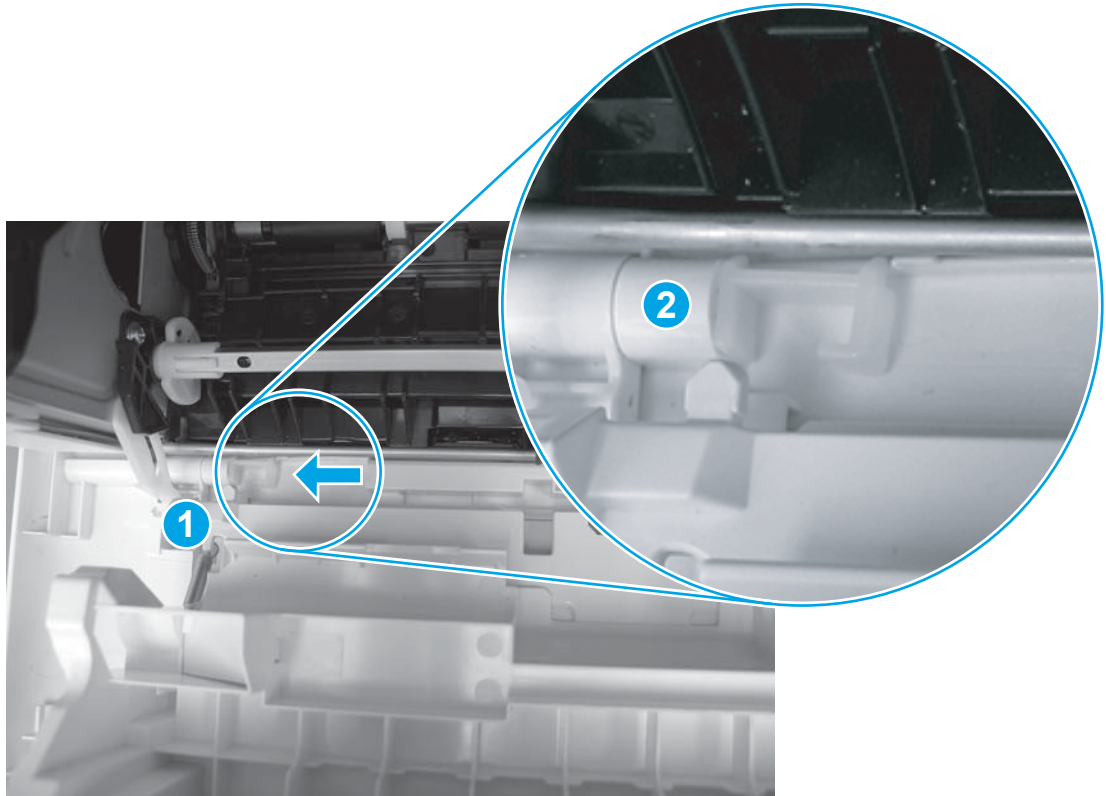
Figure 1-1208 Install the tray



Removal and replacement: Control panel FFC, (M403/M402)

- [Introduction](#)
- [Step 1: Remove Tray 2](#)
- [Step 2: Remove the cartridge door assembly](#)
- [Step 3: Remove the left cover](#)
- [Step 4: Remove the right cover](#)
- [Step 5: Remove the top cover \(M403/M402\)](#)
- [Step 6: Remove the paper delivery tray \(output bin\)](#)
- [Step 7: Remove the control panel FFC](#)
- [Step 8: Unpack the replacement assembly](#)
- [Step 9: Install the control panel FFC](#)
- [Step 10: Install the paper delivery tray \(output bin\)](#)
- [Step 11: Install the top cover \(M403/M402\)](#)
- [Step 12: Install the right cover](#)
- [Step 13: Install the left cover](#)
- [Step 14: Install the cartridge door assembly](#)
- [Step 15: Install Tray 2](#)

Introduction

This document provides the procedures to remove and replace the control panel FFC (M403/M402 only).

Before performing service

Turn the printer power off

- Disconnect the power cable.

 **WARNING!** To avoid damage to the printer, turn the printer off, wait 30 seconds, and then remove the power cable before attempting to service the printer.

Use the table below to identify the correct part number for your printer. To order the part, go to www.hp.com/buy/parts.

Control panel FFC (M403/M402) part number

RK2-6943-000CNControl panel FFC (M403/M402)

Required tools

- #2 Phillips screwdriver with a magnetic tip.

After performing service

Turn the printer power on

- Connect the power cable.
- Use the power switch to turn the power on.

Post service test

Make sure that the printer initializes to a **Ready** state.

Print a configuration page to make sure that the printer is functioning correctly.

Step 1: Remove Tray 2

- ▲ Pull the tray straight out of the printer to remove it.

Figure 1-1209 Remove the tray



Step 2: Remove the cartridge door assembly



NOTE: If the toner cartridge was not removed prior to servicing the printer, remove it now.

1. Release one tab (callout 1), and then slide shaft (callout 2) in the direction the arrow indicates and remove it.



TIP: It might be easier to release the support shaft by using a small flat-blade screwdriver.

Figure 1-1210 Release the support shaft

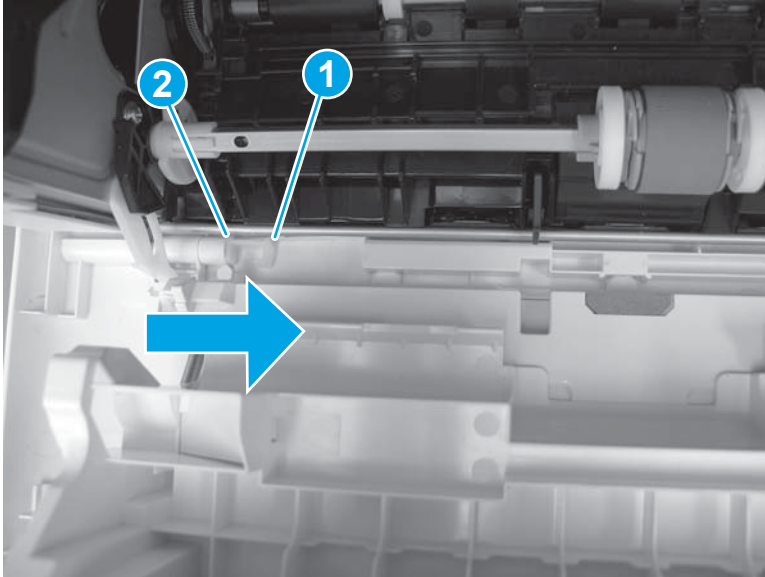

2. Release one tab (callout 1), and then slide the guide (callout 2) in the direction the arrow indicates and remove it.

Figure 1-1211 Remove the guide

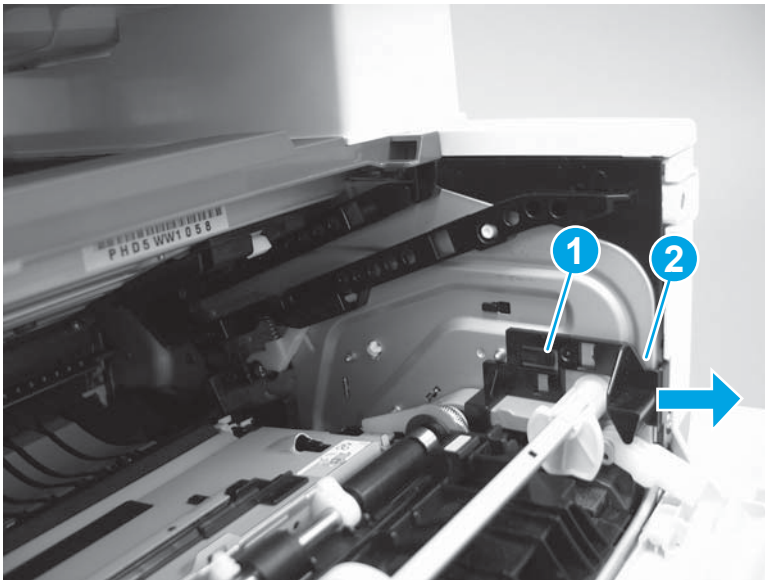

3. Remove the link arm (callout 1).

Figure 1-1212 Remove the link arm

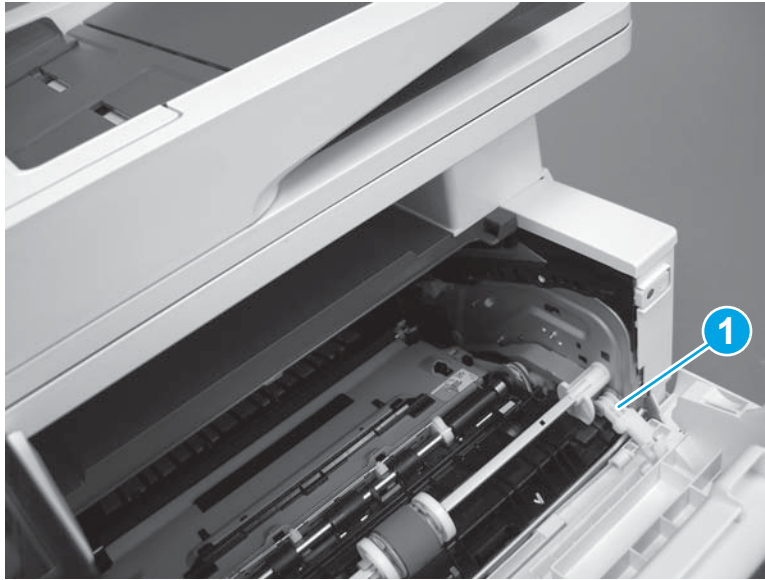

4. Slide the cartridge door assembly (callout 1) in the direction the arrow indicates and remove it.

Figure 1-1213 Remove the door

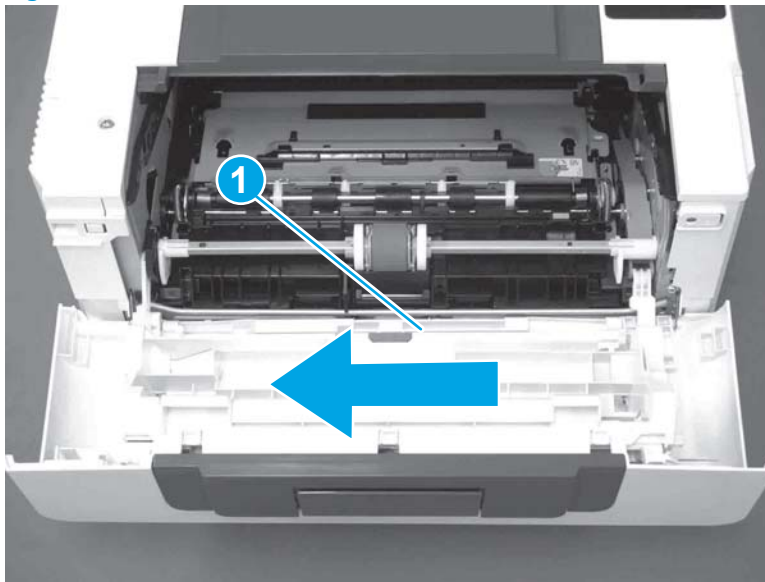

5. Remove the link (callout 1) from the cartridge door assembly (callout 2).

Figure 1-1214 Release the left-side retainer arm

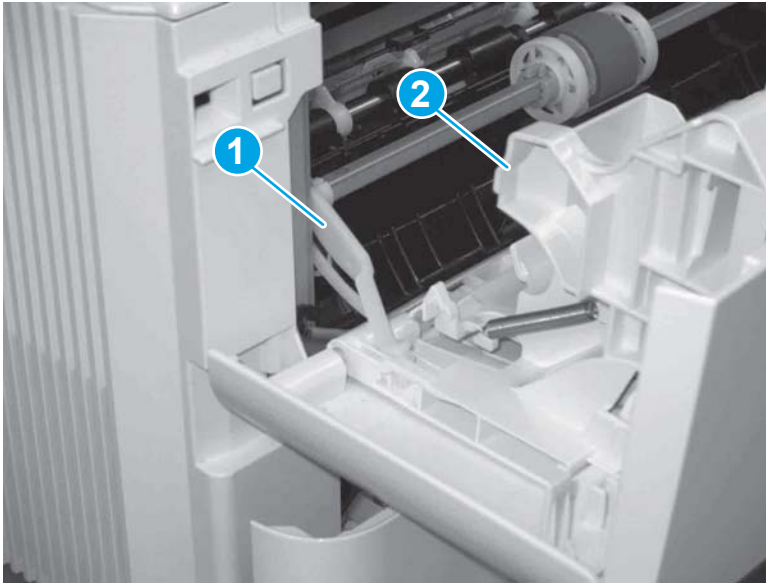

Step 3: Remove the left cover

1. Remove one screw (callout 1).

Figure 1-1215 Remove one screw

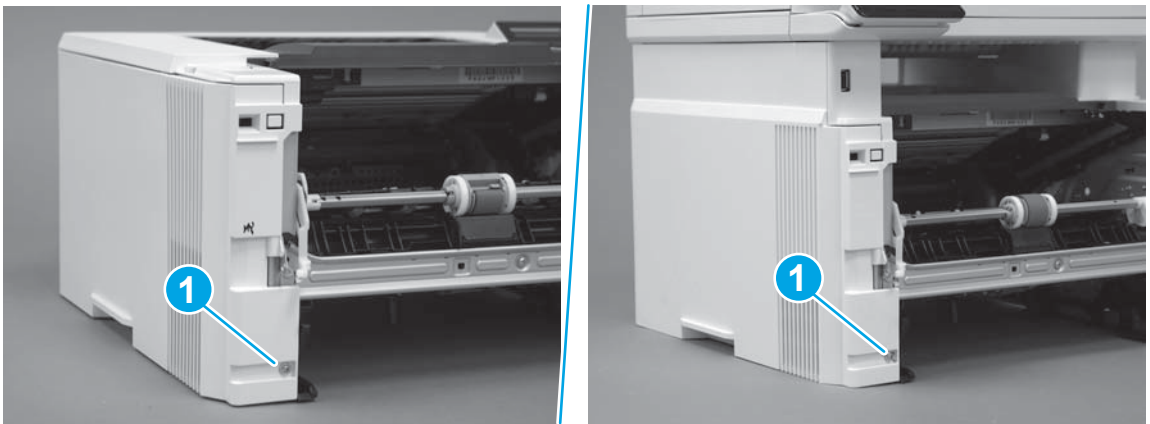

2. Open the rear door, release two bosses (callout 1), and then release three tabs (callout 2).

Figure 1-1216 Release two bosses and three tabs

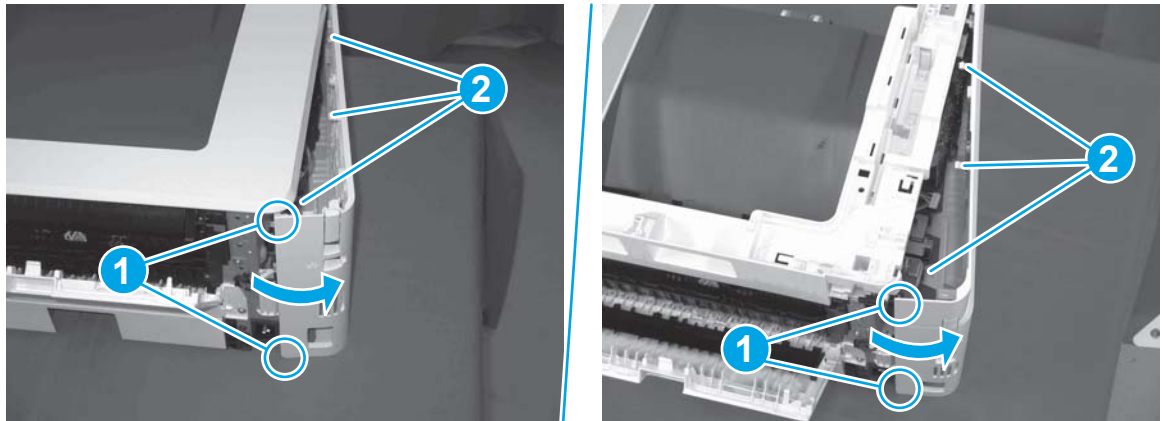

3. At the front of the printer, do one of the following:

- **M403/M402:** Release two bosses (callout 1), and then remove the cover (callout 2).
- **M427/M426:** Release one tab (callout 3), two bosses (callout 4), and then remove the cover (callout 5).

CAUTION: Be careful when releasing the upper bosses on the M427/M426 cover. One portion of the cover (callout 6) is fragile and is easily broken.

Figure 1-1217 Remove the cover

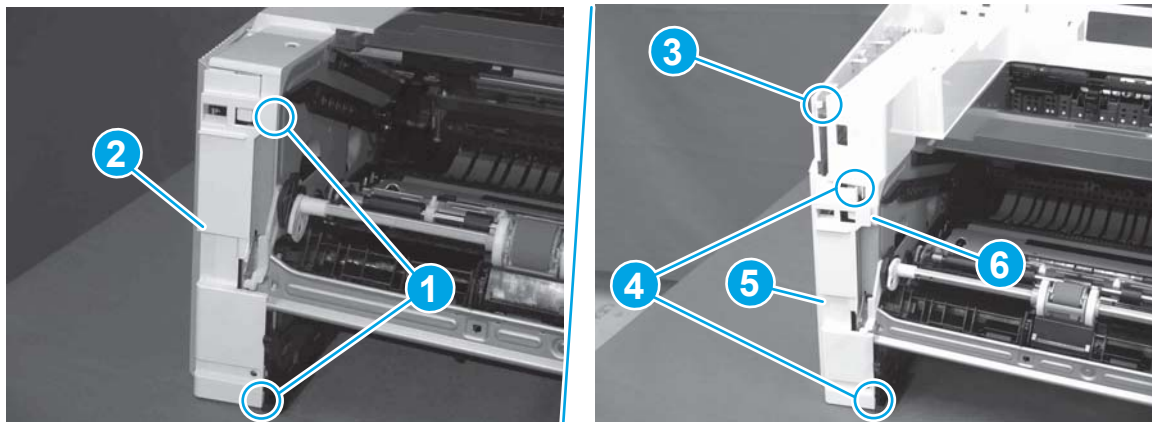

Step 4: Remove the right cover

1. Remove one screw (callout 1).

Figure 1-1218 Remove one screw

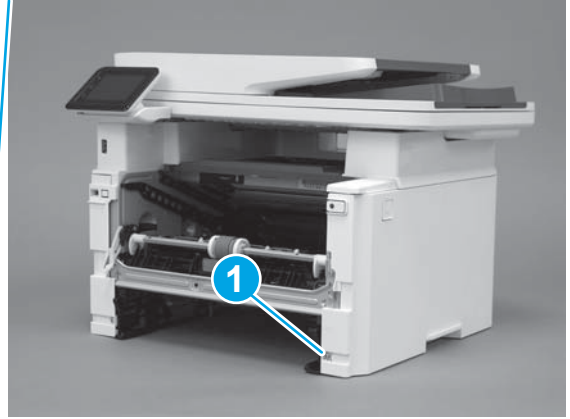
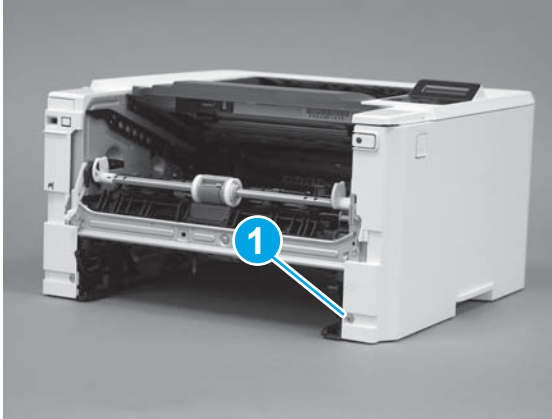

2. At the front of the printer, release two bosses (callout 1), and then release three tabs (callout 2).

Figure 1-1219 Release two bosses and three tabs

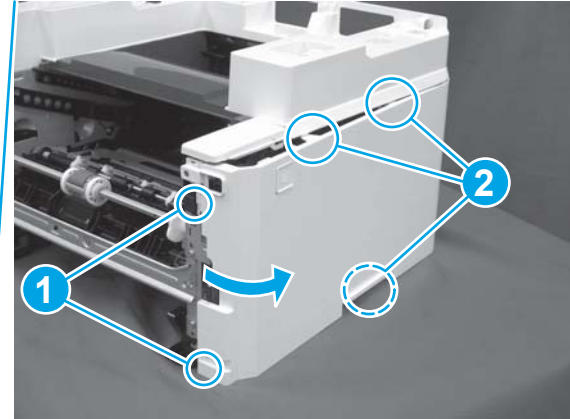
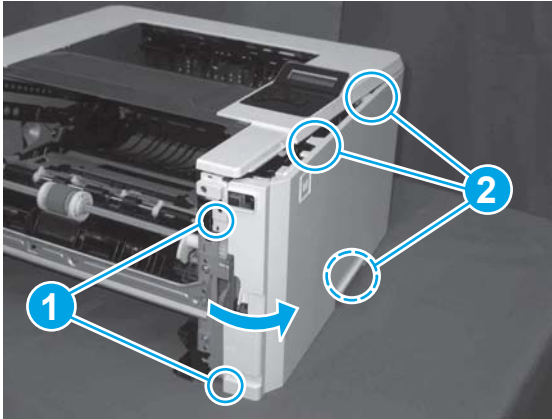

3. Open the rear door, release two bosses (callout 1), and then remove the cover (callout 2).

Figure 1-1220 Remove the cover

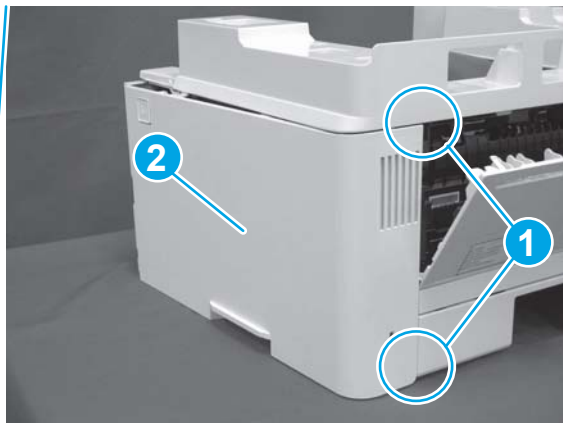
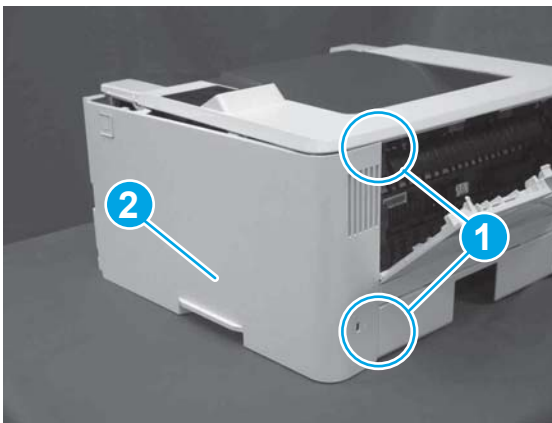

Step 5: Remove the top cover (M403/M402)

1. Remove one screw (callout 1).

Figure 1-1221 Remove one screw



2. At the right side of the printer, release the one boss (callout 1), and then release one tab (callout 2).

Figure 1-1222 Release one boss and one tab

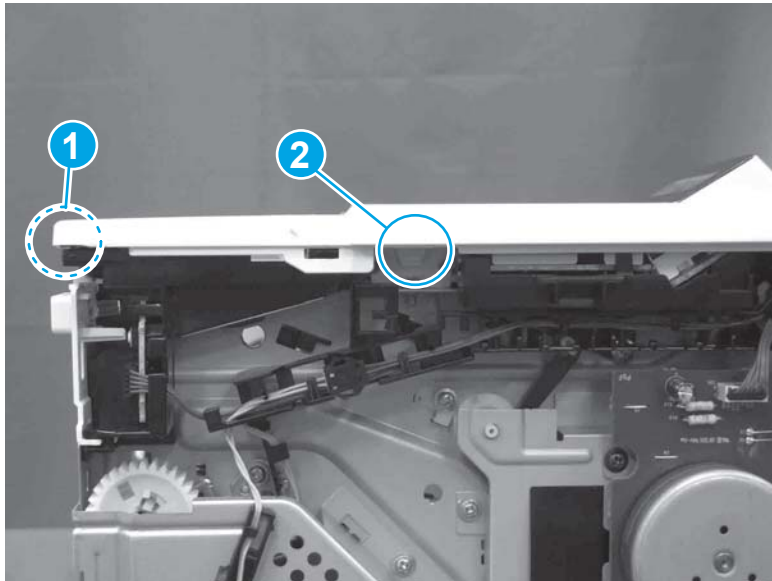

3. Release four tabs (callout 1), release four bosses (callout 2), and then remove the top cover (callout 3).



 **TIP:** Open the rear door to make releasing the bosses (callout 3) easier.

Figure 1-1223 Remove the cover

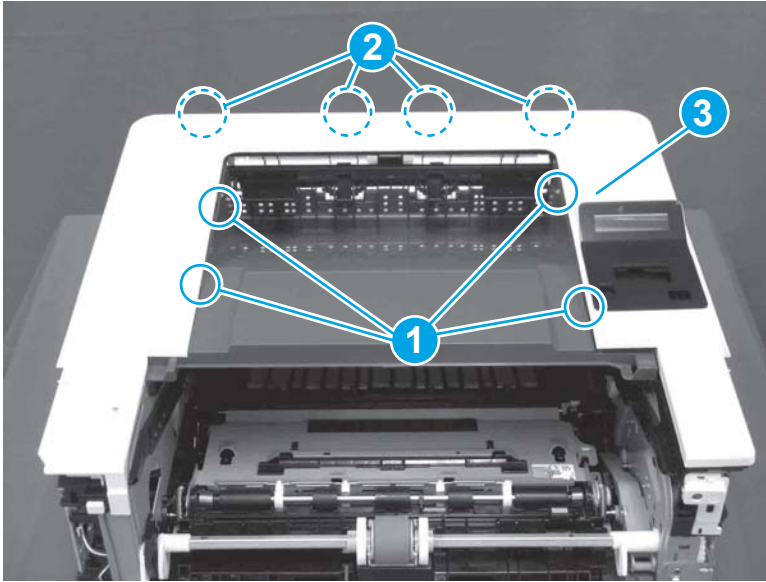

Step 6: Remove the paper delivery tray (output bin)

 **NOTE:** This procedure shows the M403/M402 model, however, the paper delivery tray (output bin) removal is similar for the M427/M426 printer.

- ▲ Release two bosses (callout 1), release two tabs (callout 2), and then remove the paper delivery tray (output bin; callout 3).

Figure 1-1224 Release two tabs

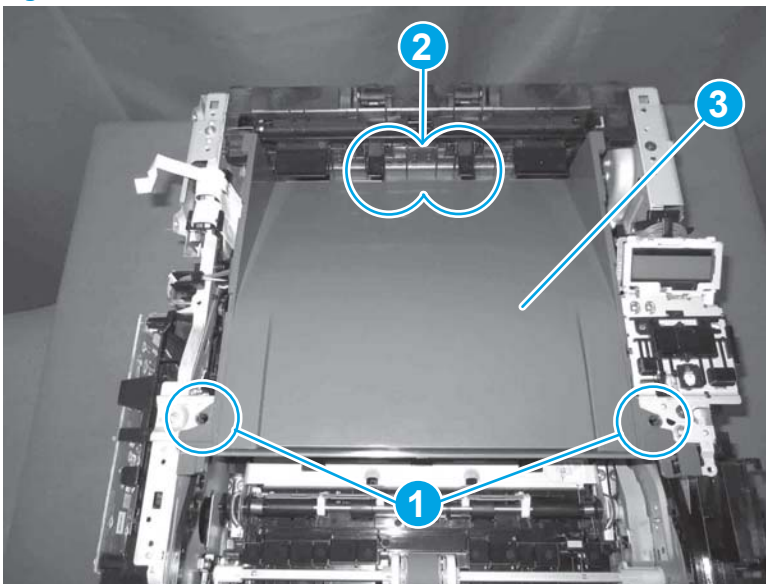

Step 7: Remove the control panel FFC

1. Disconnect the FFC from the control panel (callout 1).

Figure 1-1225 Disconnect the FFC

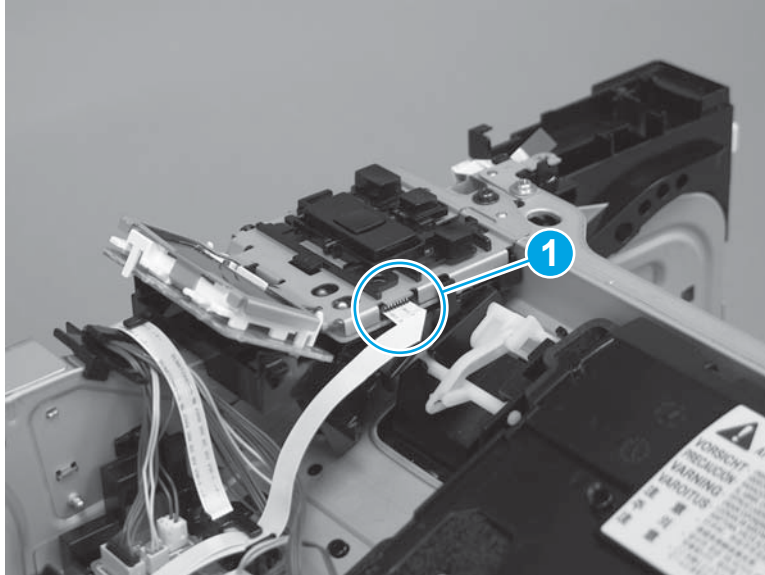

2. Release the FFC from the guide (callout 1).

 **NOTE:** The near field communication (NFC) FFC might need to be moved out of the way to gain access to the control panel FFC.

Figure 1-1226 Release the FFC from the guide

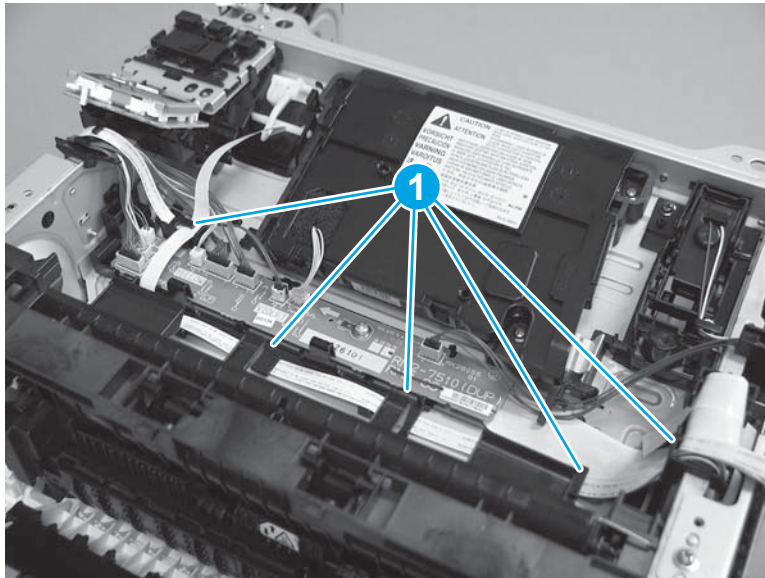

3. Disconnect one FFC (callout 1), and then remove the FFC.

Figure 1-1227 Disconnect and remove the FFC

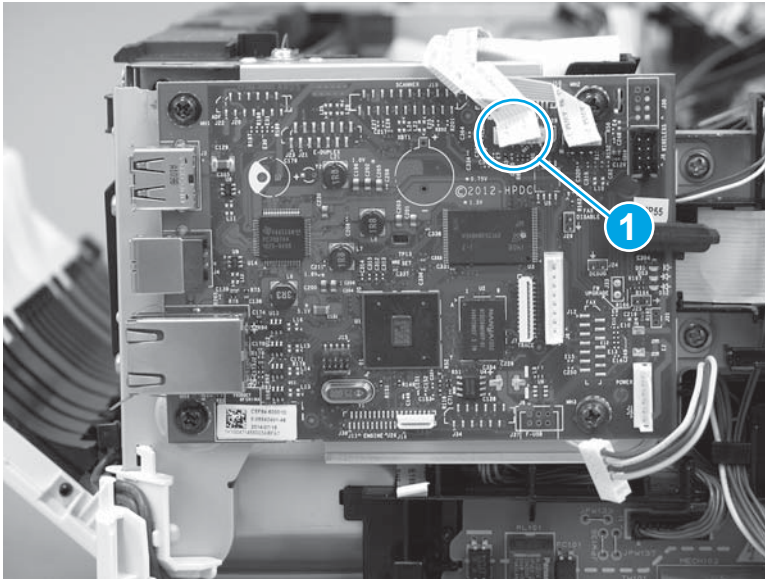

Step 8: Unpack the replacement assembly

Unpack the replacement part from the packaging.

<http://www8.hp.com/us/en/hp-information/environment/product-recycling.html>



NOTE: HP recommends responsible disposal of the defective part.

Figure 1-1228 Recycle and unpack

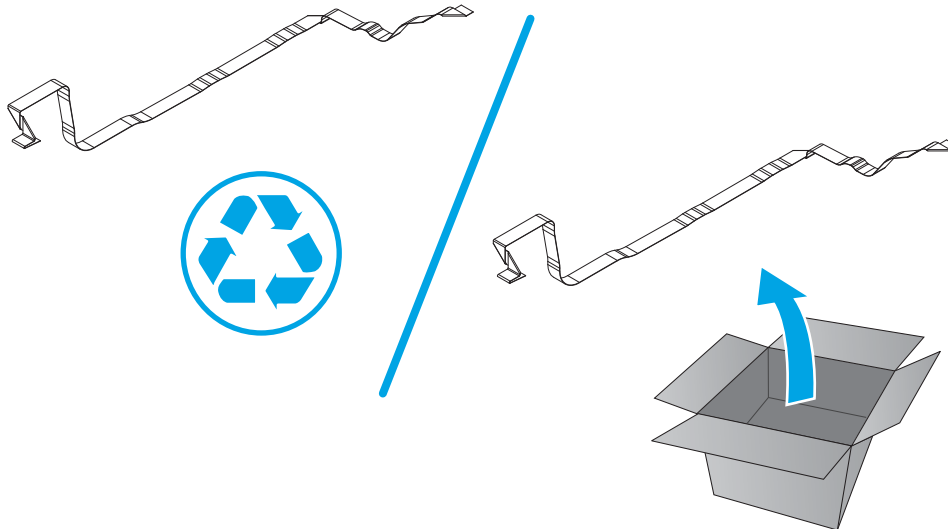

Step 9: Install the control panel FFC

1. Connect the FFC (callout 1) to the formatter PCA.

Figure 1-1229 Connect the FFC

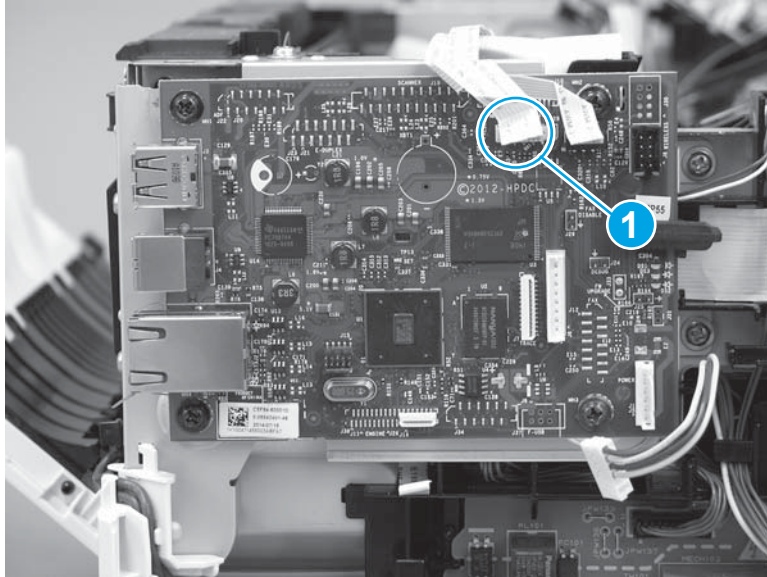

2. Install the FFC in the guide (callout 1).

 **NOTE:** The near field communication (NFC) FFC might need to be moved out of the way to gain access to the control panel FFC.

Figure 1-1230 Install the FFC in the guide

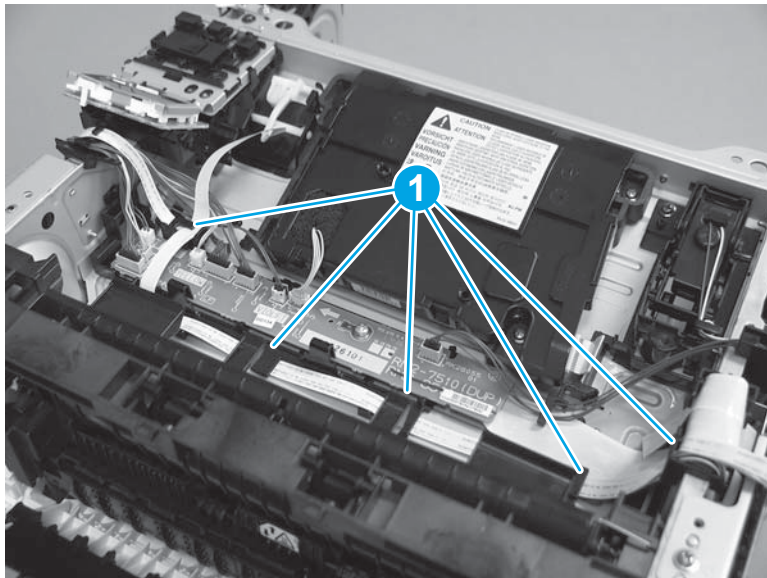

3. Connect the FFC to the control panel (callout 1).

Figure 1-1231 Connect the FFC

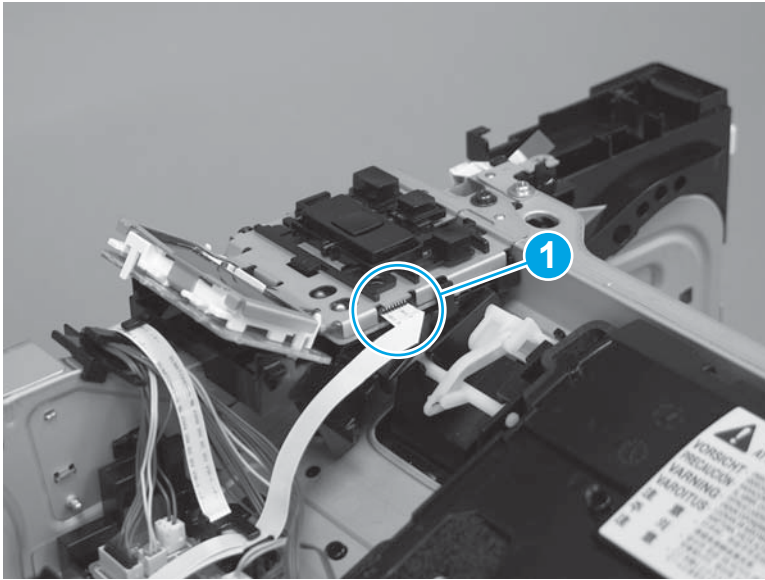

Step 10: Install the paper delivery tray (output bin)



NOTE: This procedure shows the M403/M402 model, however, the paper delivery tray (output bin) removal is similar for the M427/M426 printer.

- ▲ Position the remove the paper delivery tray (output bin; callout 1) on the printer, engage two tabs (callout 2), and then engage two bosses (callout 3).

Figure 1-1232 Engage two tabs

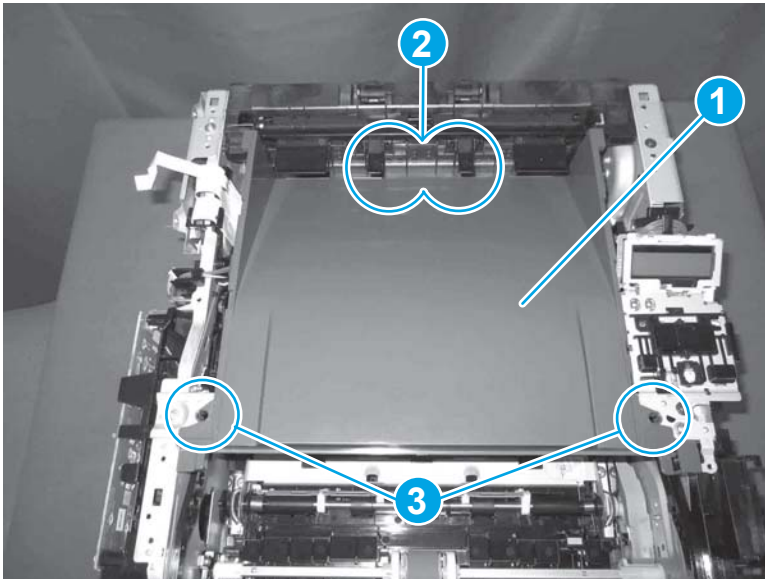

Step 11: Install the top cover (M403/M402)

1. Position the rear edge of the cover on the printer.

Figure 1-1233 Install the cover

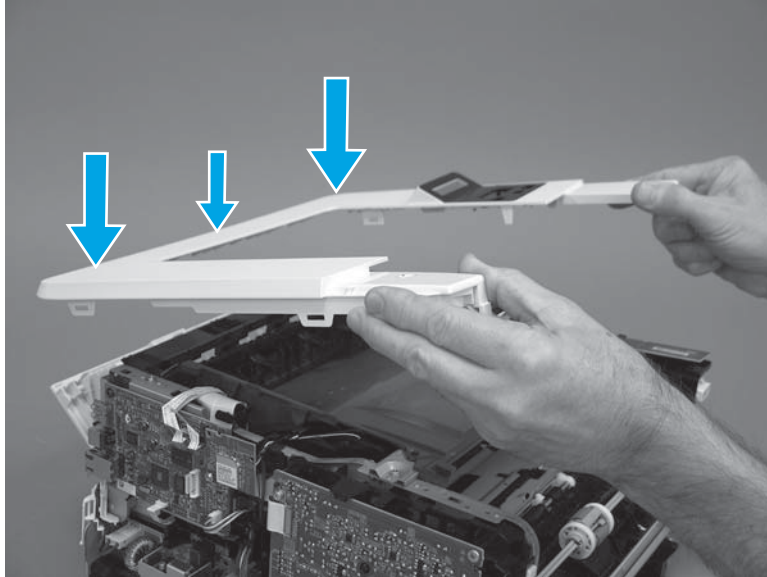

2. Engage four bosses (callout 1), rotate the front of the cover down (callout 2) and onto from the printer, and then engage four tabs (callout 3).

Figure 1-1234 Engage four bosses and tabs

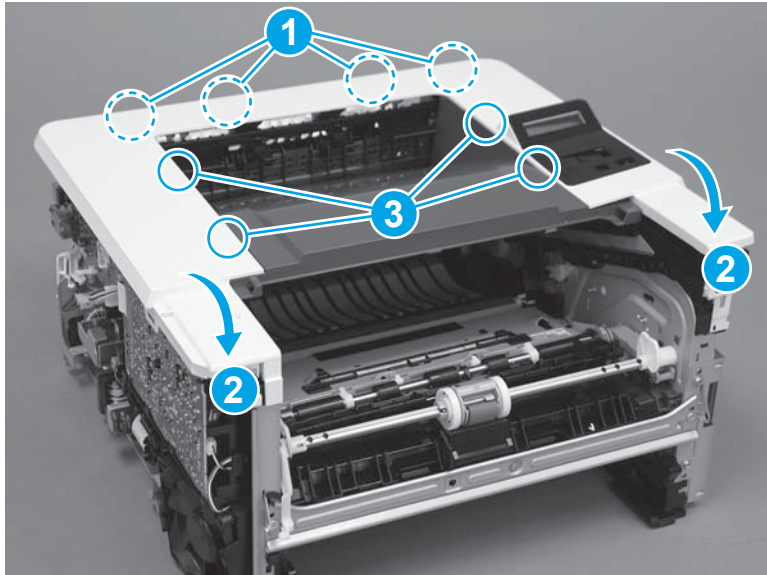

3. At the right side of the printer, engage the one boss and one tab (callout 1).

Figure 1-1235 Engage one boss and one tab

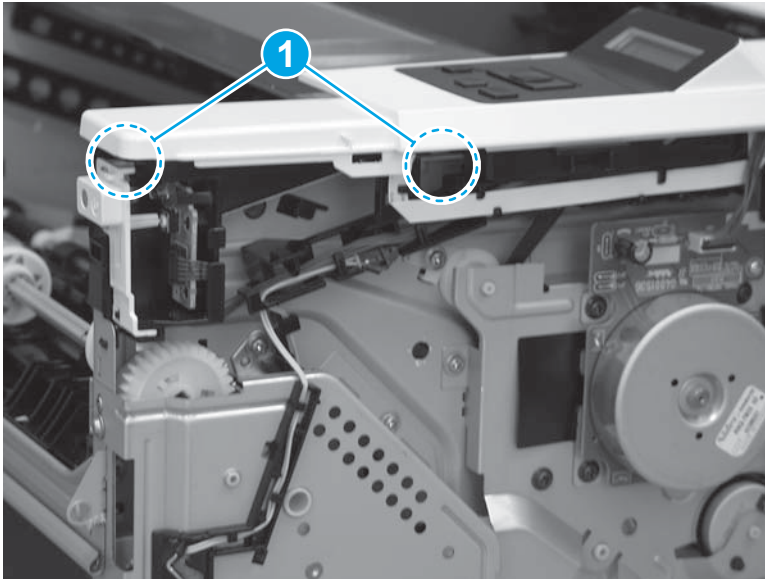

4. Install one screw (callout 1).

Figure 1-1236 Install one screw

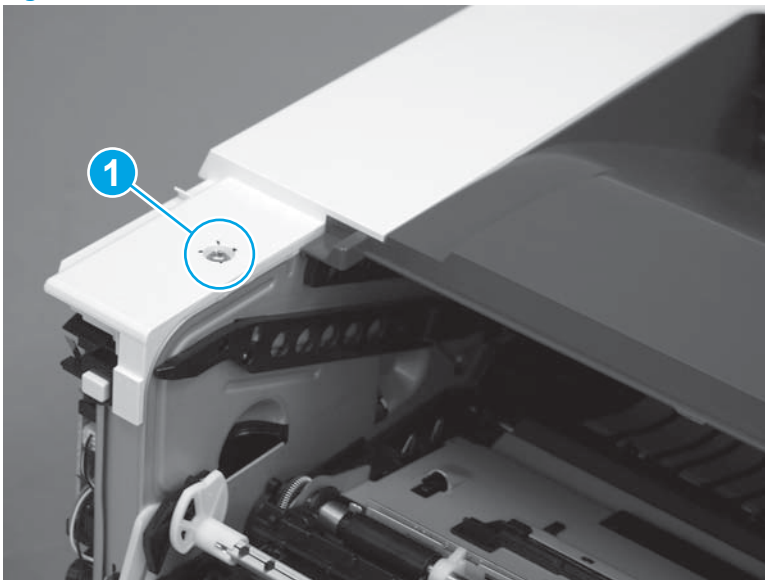

Step 12: Install the right cover

1. Position the cover (callout 1) on the printer, and then engage two bosses (callout 2).

Figure 1-1237 Install the cover

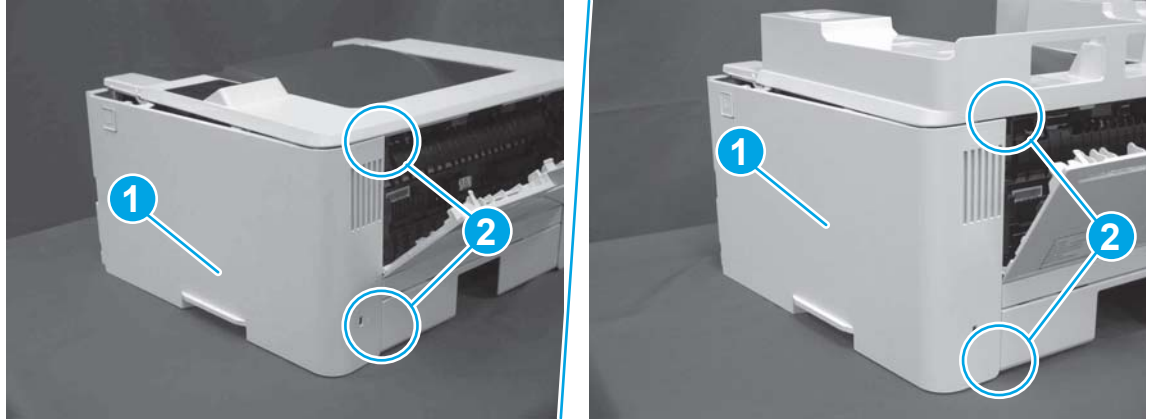

2. Rotate the front of the cover onto the printer (callout 1), engage three (callout 2) tabs, and then engage two bosses (callout 3).

Figure 1-1238 Engage two bosses and one tab

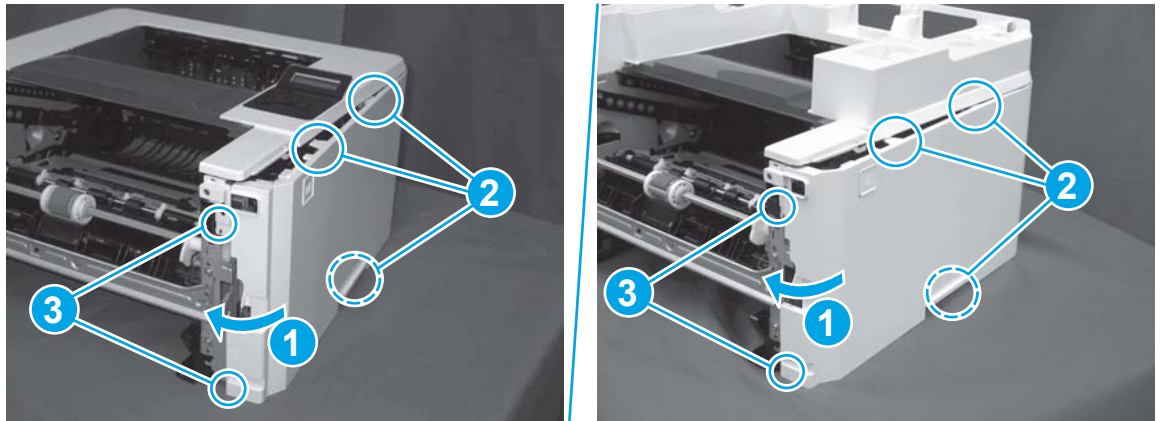

3. Make sure that the power switch (callout 1) and cartridge door assembly button (callout 2) correctly function.



NOTE: Remove, and then reinstall the cover if the switch or button does not correctly function.

Figure 1-1239 Check the power switch and cartridge door assembly button

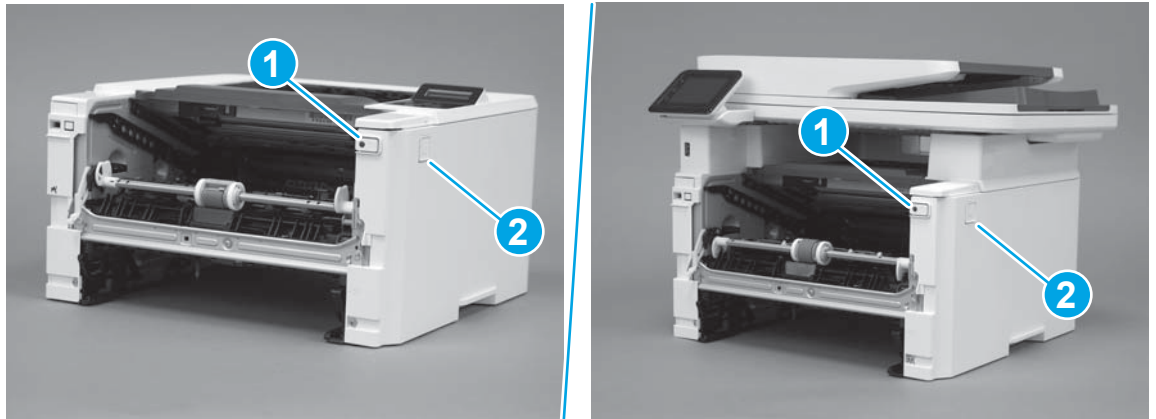

4. Install one screw (callout 1).

Figure 1-1240 Install one screw



Step 13: Install the left cover

1. At the front of the printer, do one of the following:
 - **M403/M402:** Position the cover on the printer (callout 1), and then engage two bosses (callout 2).
 - **M427/M426:** Position the cover on the printer (callout 3), engage one tab (callout 4), and then engage two bosses (callout 4).

Figure 1-1241 Install the cover

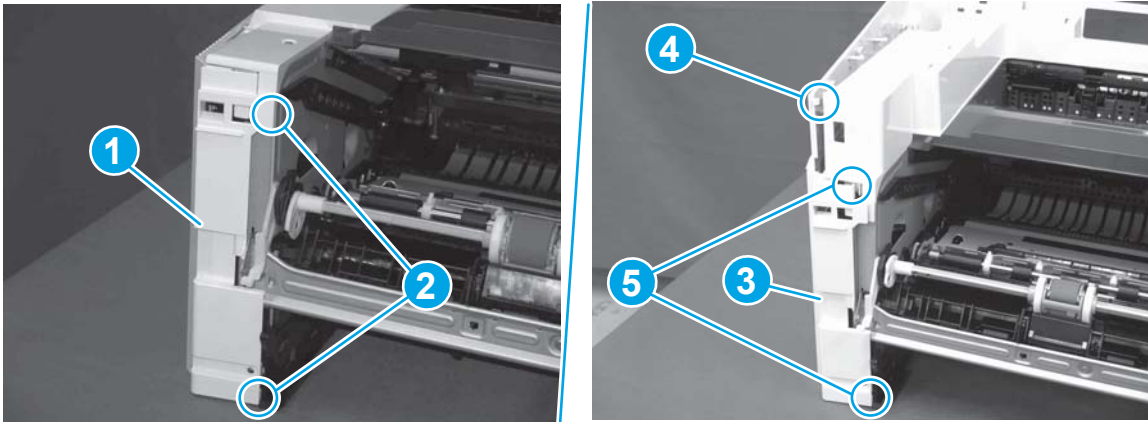

- Carefully rotate the rear of the cover onto the printer (callout 1), engage three tabs (callout 2), and then engage two bosses (callout 3).

Figure 1-1242 Engage three tabs and two bosses

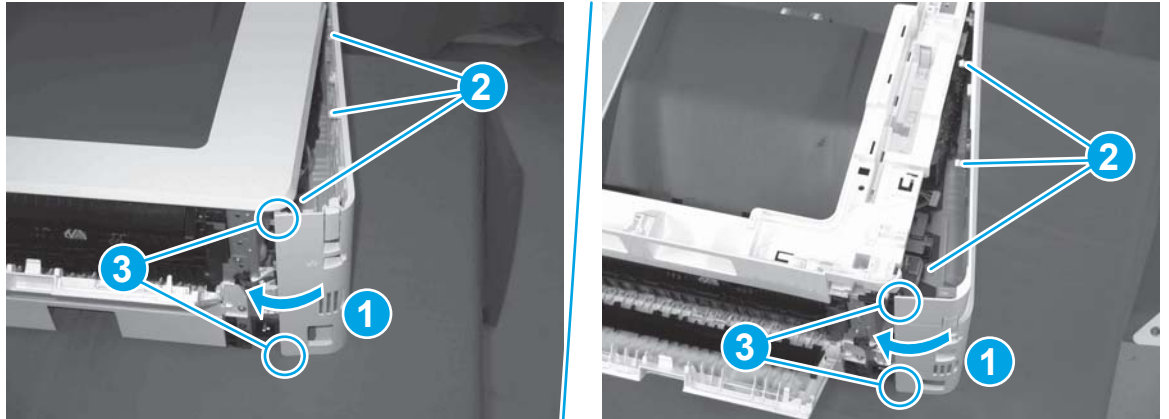

- Install one screw (callout 1).

Figure 1-1243 Install one screw

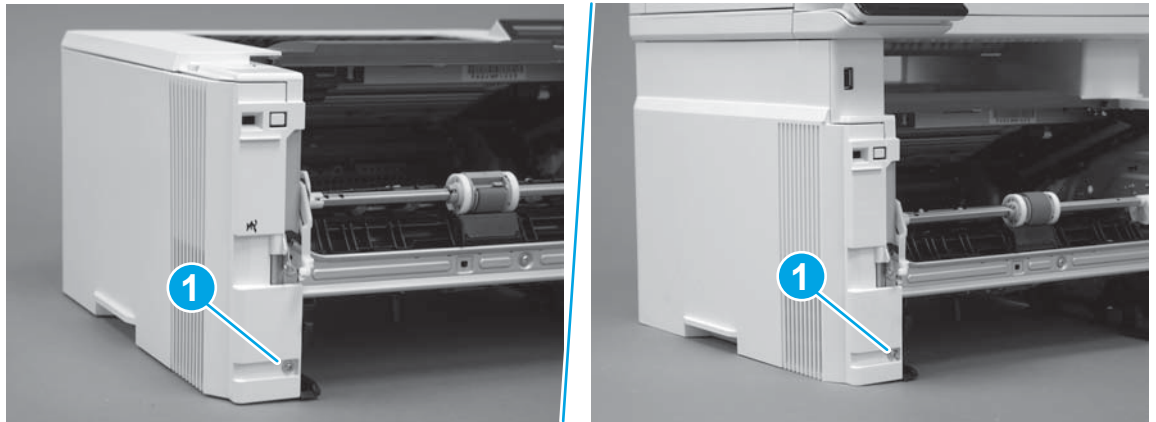

Step 14: Install the cartridge door assembly

 **Reinstallation tip:** After a replacement door is installed, make sure to install the nameplate (supplied in the kit) corresponding to the printer name on the door.

- Position the door close to the printer, and then engage the keyed pin on the left-side retainer arm with the hole in the door.

Figure 1-1244 Engage the left-side retainer arm

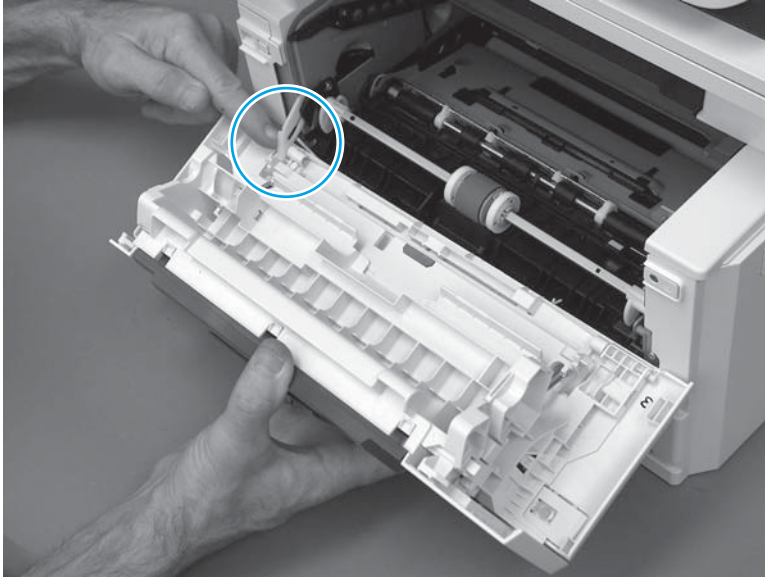

2. Engage the right-side door hinge pin with the hole in the chassis (callout 1).

Figure 1-1245 Install the door

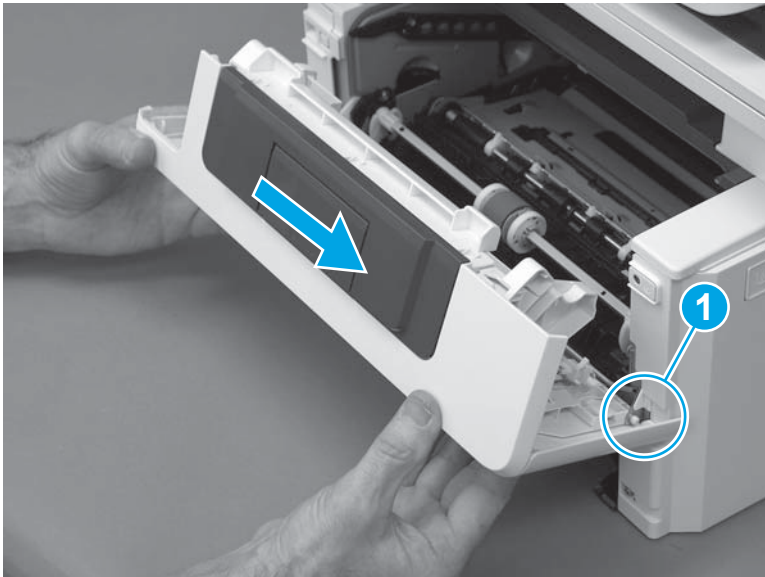

3. Install the link (callout 1).

 **IMPORTANT:** Make sure that the link snaps into place on the arm (callout 2). The link actuates the fuser pressure-release mechanism.

Figure 1-1246 Install the pressure-release link

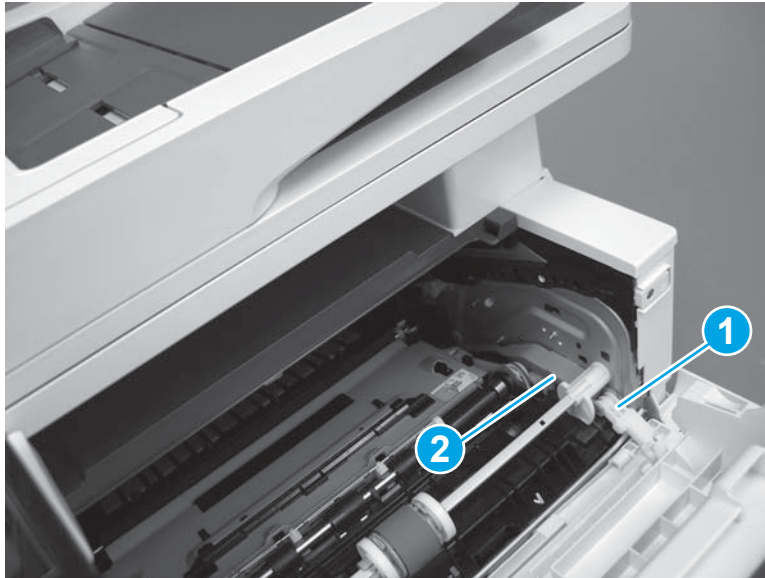

4. Slide the guide into the printer (callout 1), and then make sure that the tab (callout 2) snaps into place to secure the guide to the chassis.

Figure 1-1247 Install the guide

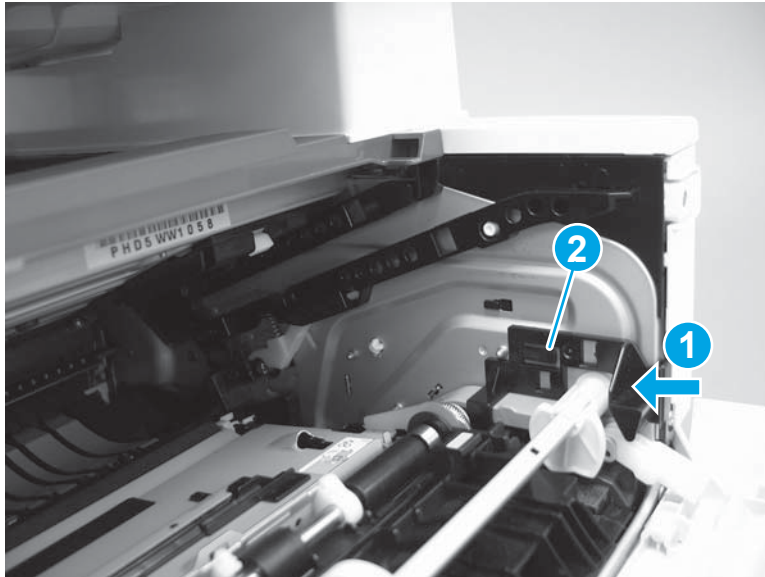

5. Position the shaft on the door, and then align the left-side hinge on the door with the hole in the chassis (callout 1).

Figure 1-1248 Align the hinge

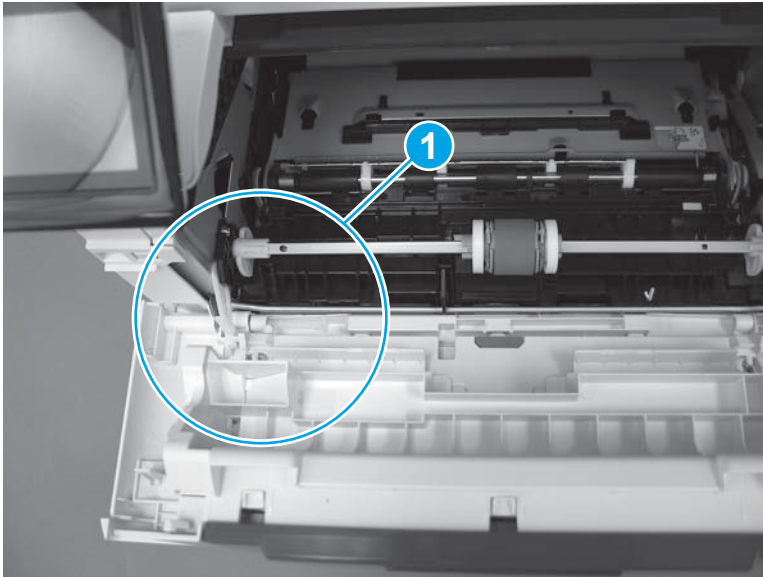

6. Push the shaft towards the left side of the printer to install it (callout 1).

 **Reinstallation tip:** Make sure that the support shaft is fully installed and correctly orientated (callout 2) so that it will not interfere with the door opening and closing.

Figure 1-1249 Install the support shaft



Step 15: Install Tray 2

- ▲ Slide the tray straight into the printer to install it.

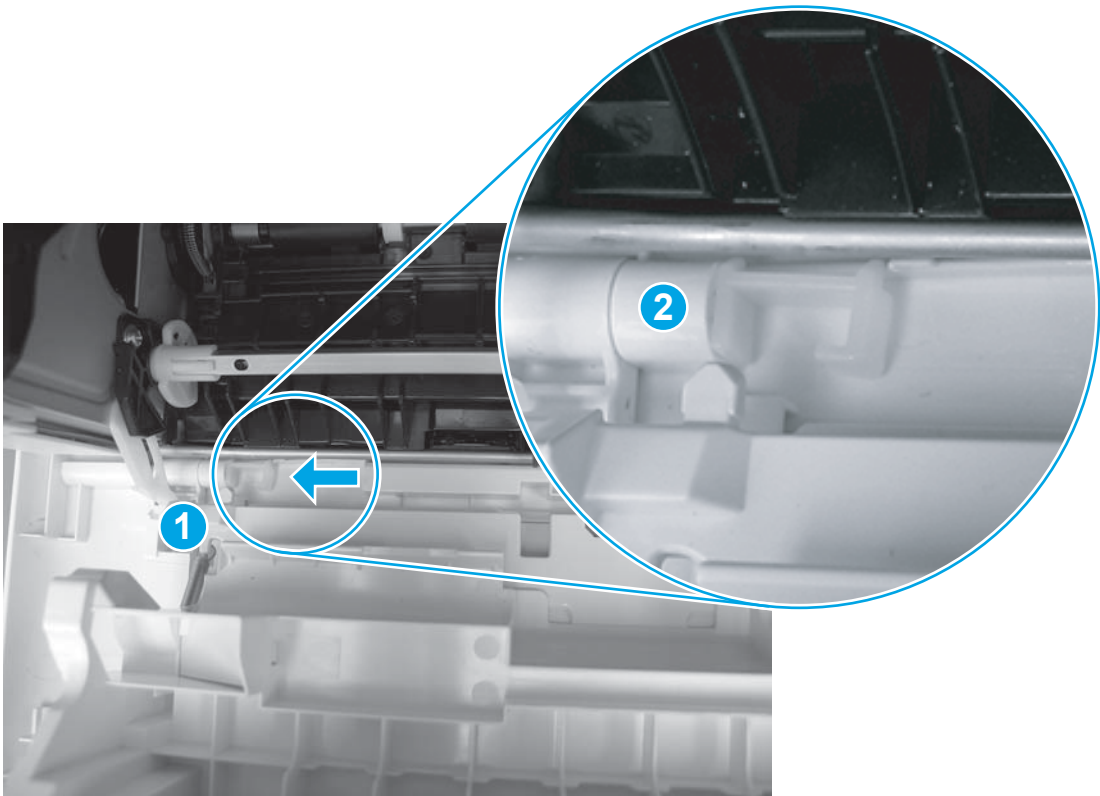
Figure 1-1250 Install the tray



Removal and replacement: Formatter FFC

- [Introduction](#)
- [Step 1: Remove Tray 2](#)
- [Step 2: Remove the cartridge door assembly](#)
- [Step 3: Remove the left cover](#)
- [Step 4: Remove the right cover](#)
- [Step 5: Remove the integrated scanner assembly \(M427/M246\)](#)
- [Step 6: Remove the control panel \(M427/M246\)](#)
- [Step 7: Remove the top cover \(M427/M426\)](#)
- [Step 8: Remove the top cover \(M403/M402\)](#)
- [Step 9: Remove the sheet-metal formatter bracket and formatter PCA](#)
- [Step 10: Remove the formatter FFC](#)
- [Step 11: Unpack the replacement assembly](#)
- [Step 12: Install the formatter FFC](#)
- [Step 13: Install the sheet-metal formatter bracket and formatter PCA](#)
- [Step 14: Install the top cover \(M403/M402\)](#)
- [Step 15: Install the top cover \(M427/M426\)](#)
- [Step 16: Install the control panel \(M427/M246\)](#)
- [Step 17: Install the integrated scanner assembly \(M427/M246\)](#)
- [Step 18: Install the right cover](#)
- [Step 19: Install the left cover](#)
- [Step 20: Install the cartridge door assembly](#)
- [Step 21: Install Tray 2](#)

Introduction

This document provides the procedures to remove and replace the formatter flat-flexible cable (FFC).

Before performing service

Turn the printer power off

- Disconnect the power cable.

 **WARNING!** To avoid damage to the printer, turn the printer off, wait 30 seconds, and then remove the power cable before attempting to service the printer.

Use the table below to identify the correct part number for your printer. To order the part, go to www.hp.com/buy/parts.

Formatter FFC part number	
RK2-6931-000CN	Formatter FFC (M427/M426)
RK2-6920-000CN	Formatter FFC(M403/M402)

Required tools

- #2 Phillips screwdriver with a magnetic tip.
- 5.5 mm (0.22 inch) socket screwdriver.

After performing service

Turn the printer power on

- Connect the power cable.
- Use the power switch to turn the power on.

Post service test

Make sure that the printer initializes to a **Ready** state.

Print a configuration page to make sure that the printer is functioning correctly.

Step 1: Remove Tray 2

- ▲ Pull the tray straight out of the printer to remove it.

Figure 1-1251 Remove the tray



Step 2: Remove the cartridge door assembly

 **NOTE:** If the toner cartridge was not removed prior to servicing the printer, remove it now.

1. Release one tab (callout 1), and then slide shaft (callout 2) in the direction the arrow indicates and remove it.

 **TIP:** It might be easier to release the support shaft by using a small flat-blade screwdriver.

Figure 1-1252 Release the support shaft

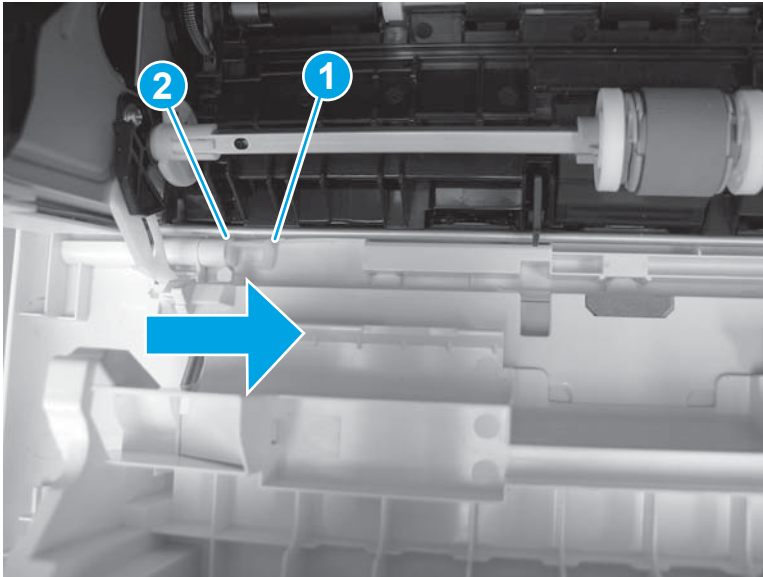

2. Release one tab (callout 1), and then slide the guide (callout 2) in the direction the arrow indicates and remove it.

Figure 1-1253 Remove the guide

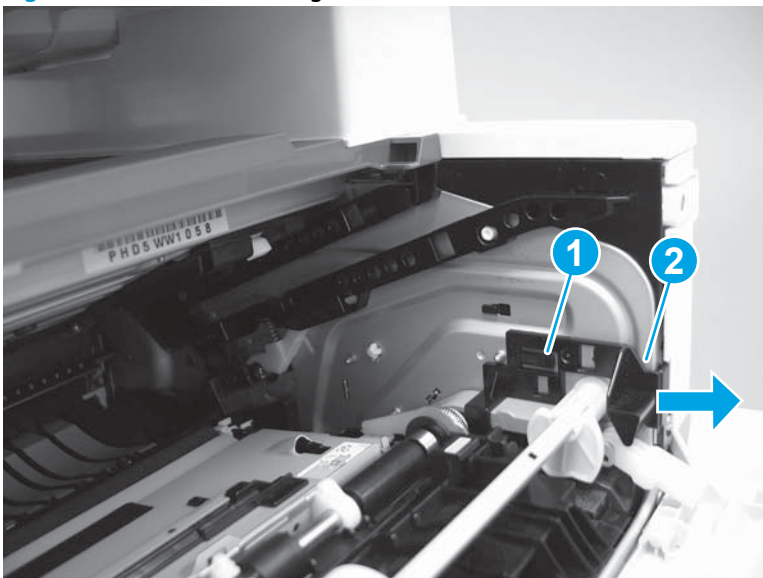

3. Remove the link arm (callout 1).

Figure 1-1254 Remove the link arm

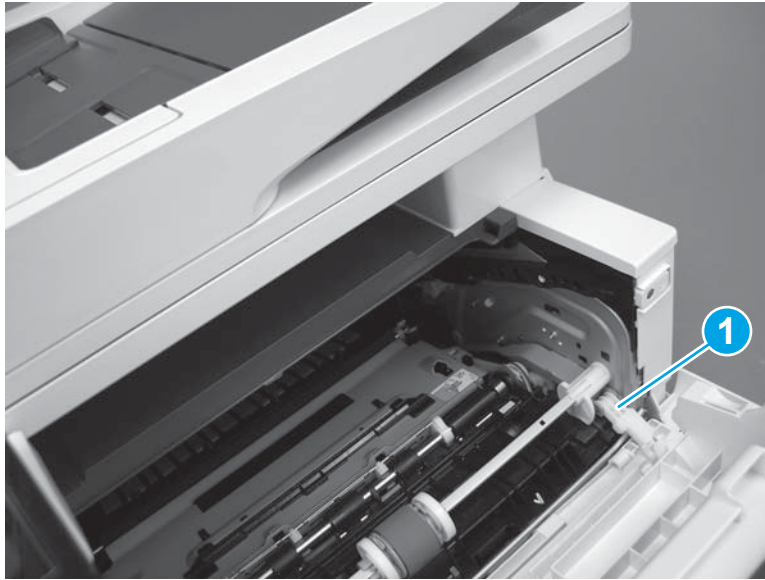

4. Slide the cartridge door assembly (callout 1) in the direction the arrow indicates and remove it.

Figure 1-1255 Remove the door

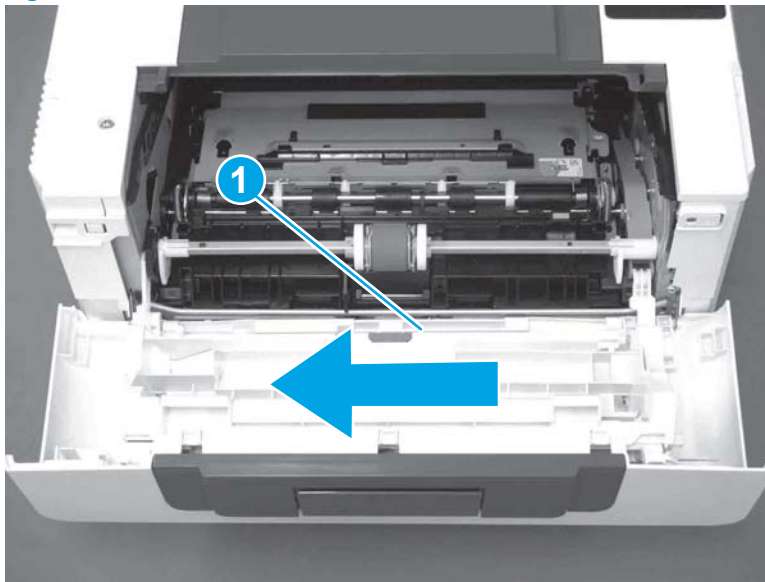

5. Remove the link (callout 1) from the cartridge door assembly (callout 2).

Figure 1-1256 Release the left-side retainer arm

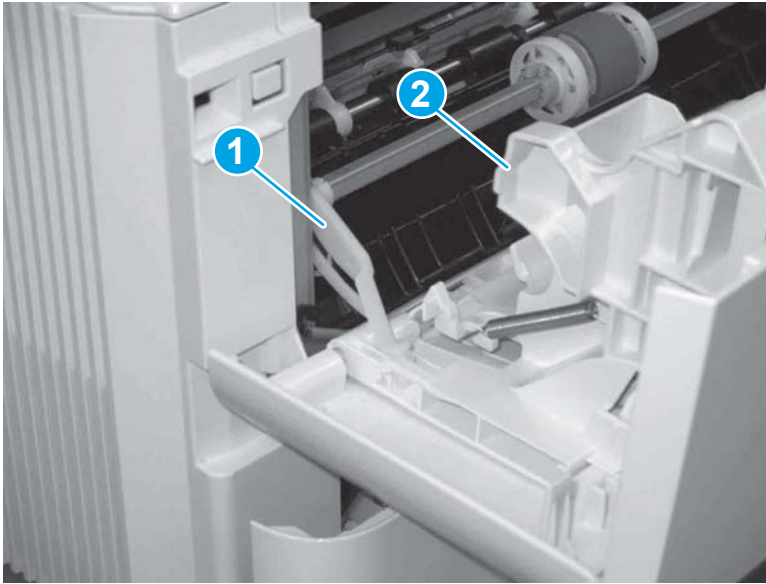

Step 3: Remove the left cover

1. Remove one screw (callout 1).

Figure 1-1257 Remove one screw

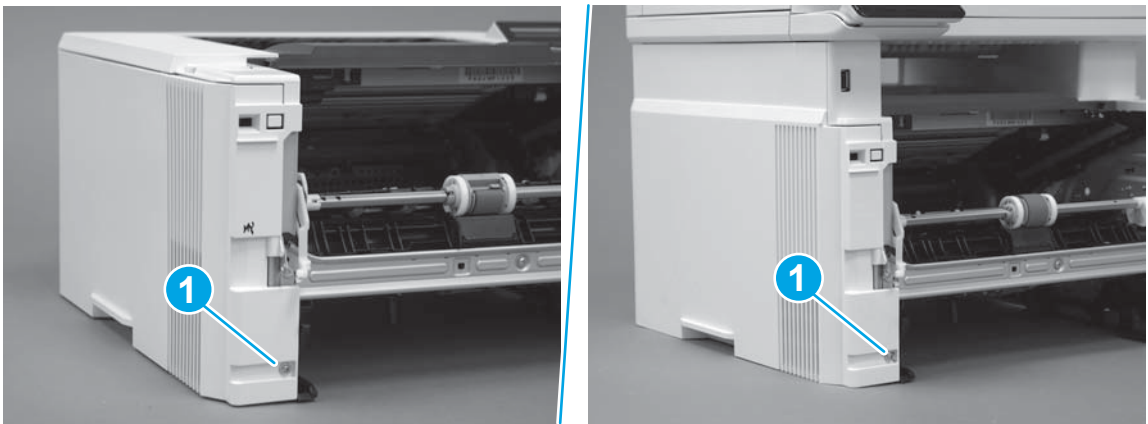

2. Open the rear door, release two bosses (callout 1), and then release three tabs (callout 2).

Figure 1-1258 Release two bosses and three tabs

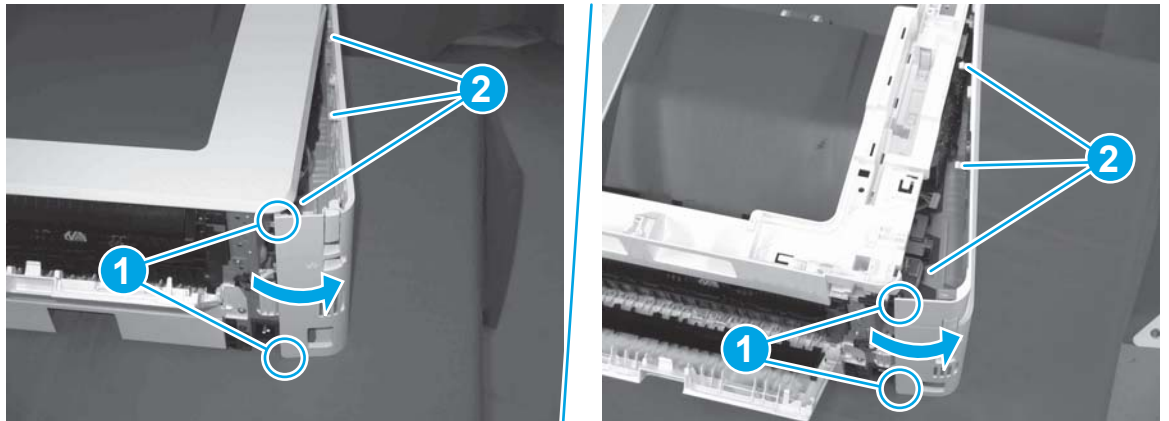

3. At the front of the printer, do one of the following:
 - **M403/M402:** Release two bosses (callout 1), and then remove the cover (callout 2).
 - **M427/M426:** Release one tab (callout 3), two bosses (callout 4), and then remove the cover (callout 5).

CAUTION: Be careful when releasing the upper bosses on the M427/M426 cover. One portion of the cover (callout 6) is fragile and is easily broken.

Figure 1-1259 Remove the cover

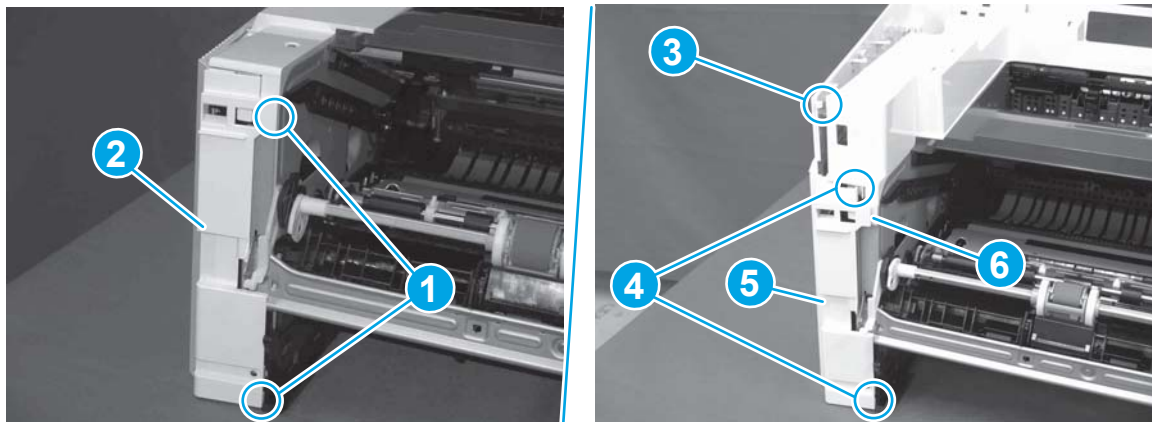

Step 4: Remove the right cover

1. Remove one screw (callout 1).

Figure 1-1260 Remove one screw



2. At the front of the printer, release two bosses (callout 1), and then release three tabs (callout 2).

Figure 1-1261 Release two bosses and three tabs

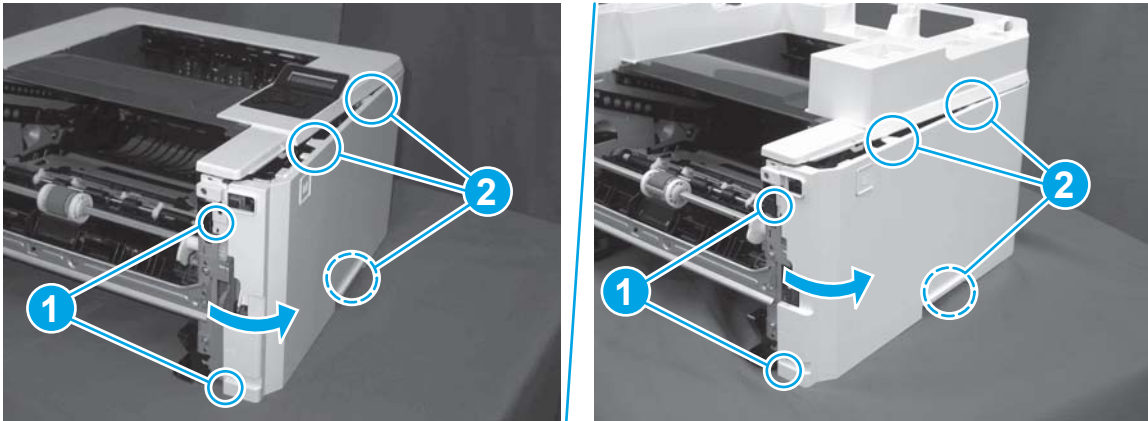

3. Open the rear door, release two bosses (callout 1), and then remove the cover (callout 2).

Figure 1-1262 Remove the cover

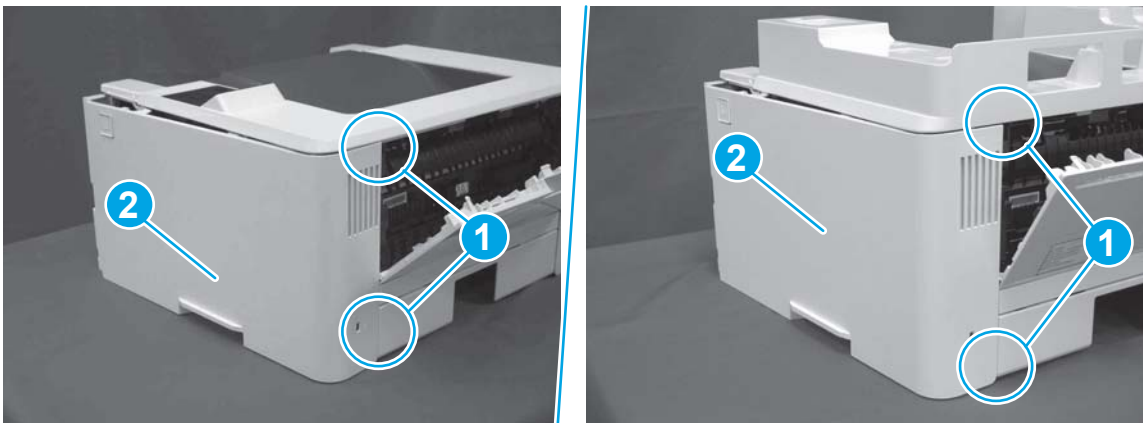

Step 5: Remove the integrated scanner assembly (M427/M246)



NOTE: The step is for the M427/M426 printer. For the M403/M402, skip this step and go to [Step 8: Remove the top cover \(M403/M402\)](#) on page 694.

 **NOTE:** M427/M426 models only. The integrated scanner assembly (ISA) includes the sub-scanner assembly (SSA) and the automatic document feeder (ADF).

1. Raise the ISA.

Figure 1-1263 Raise the ISA

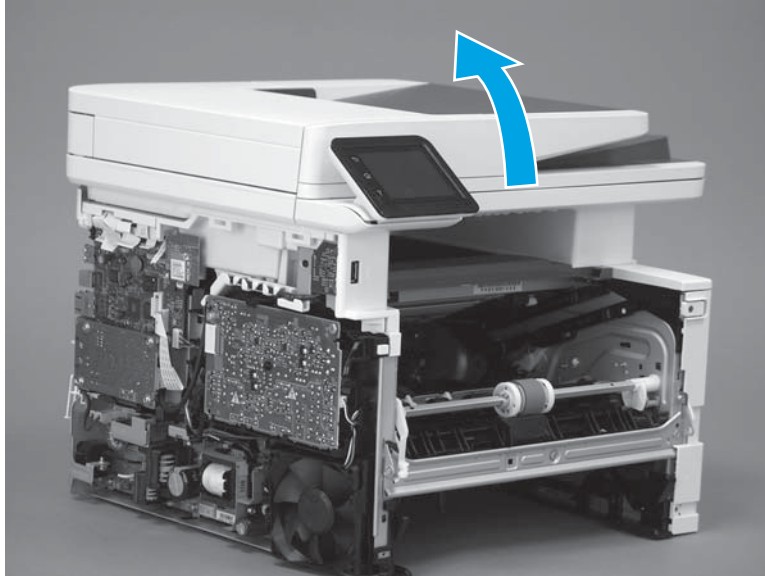

2. Release the ISA flat-flexible cable (FFC) cover (callout 1), and then remove it (callout 2).

Figure 1-1264 Remove the ISA FFC cover

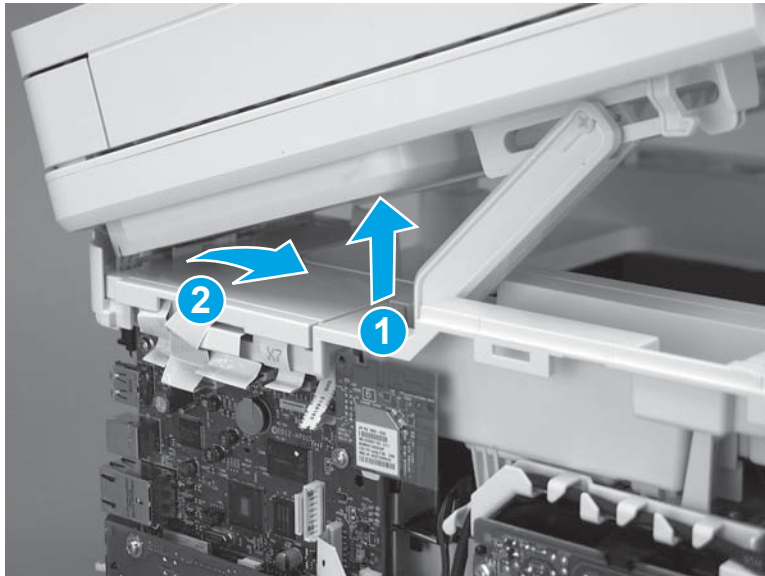

3. Disconnect three FFCs (callout 1), and then remove the ferrite (callout 2) from the holder.

⚠ CAUTION: The ferrite is not captive on the FFC. Do not lose the ferrite while handling the ISA.

Figure 1-1265 Disconnect three FFCs

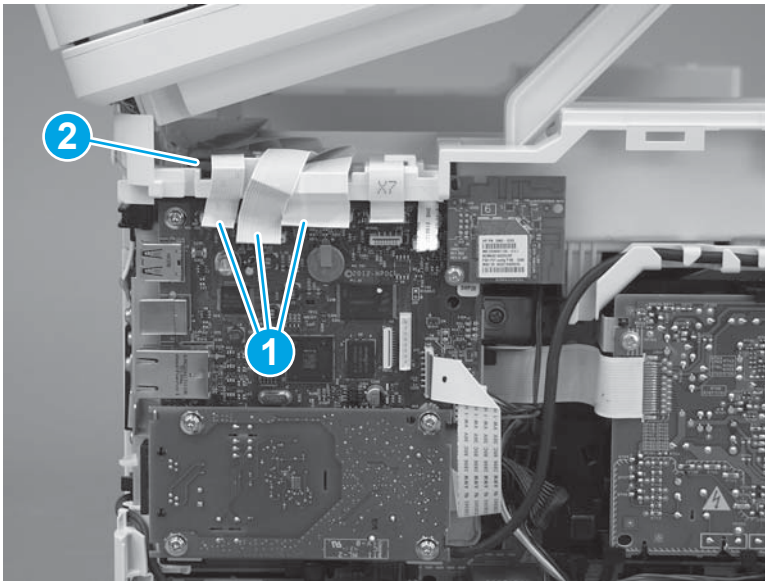

4. Remove one screw (callout 1).

Figure 1-1266 Remove one screw

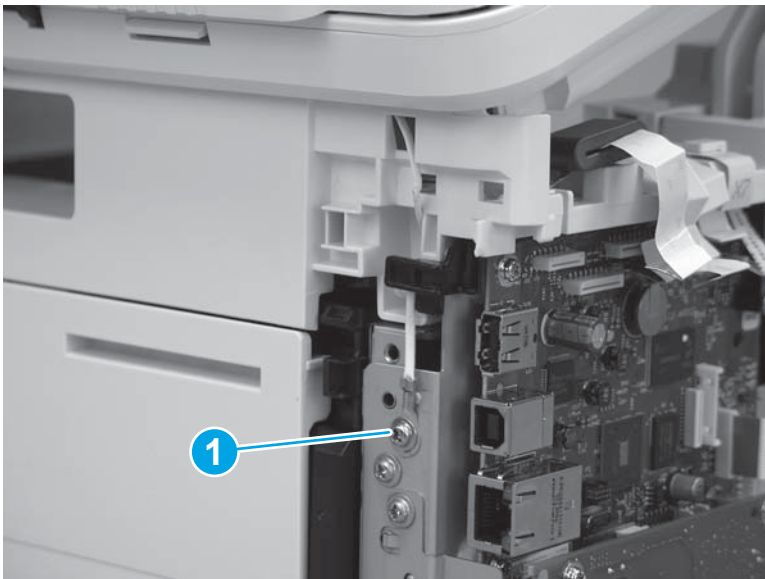

5. Pass the ground wire through the opening in the top cover.

Figure 1-1267 Pass the wire through the opening

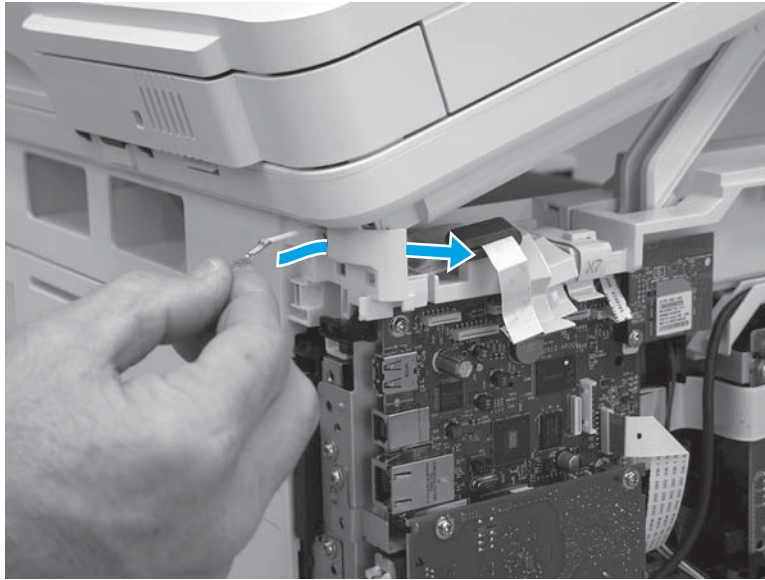

6. Release one tab (callout 1), and then rotate the ISA slider pin (callout 2) towards the front of the printer to release it.

Figure 1-1268 Release one tab and rotate the slider pin

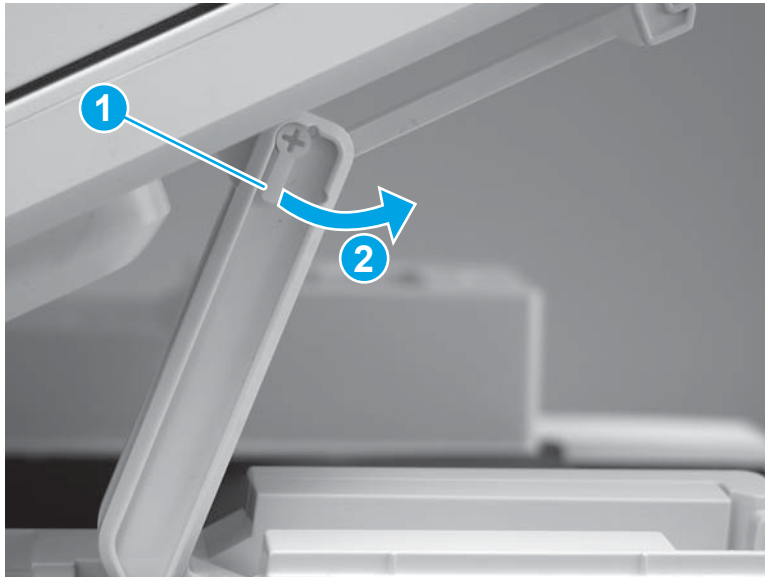

7. Remove the slider pin.

Figure 1-1269 Remove the slider pin

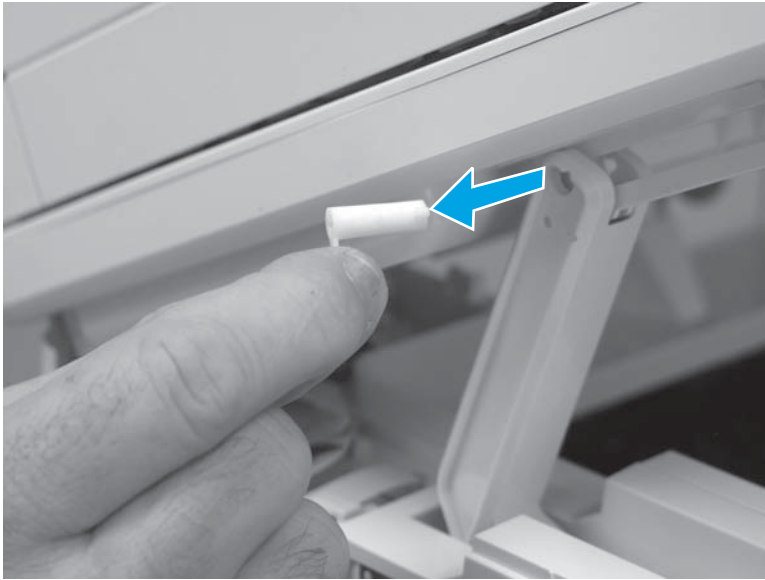

8. Rotate the ISA towards the rear of the printer until it stops.

Figure 1-1270 Rotate the ISA towards the rear of the printer



- Slide the ISA as shown to release it.

Figure 1-1271 Release the ISA

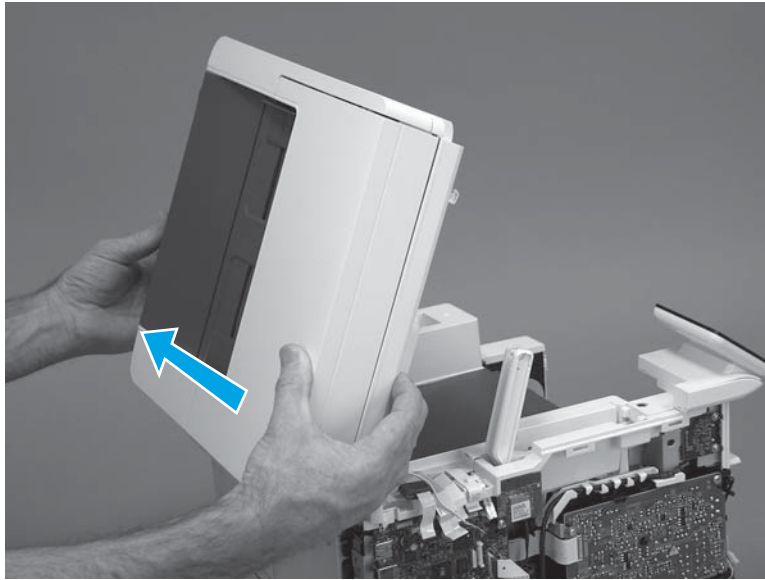

- Remove the ISA.

Figure 1-1272 Remove the ISA

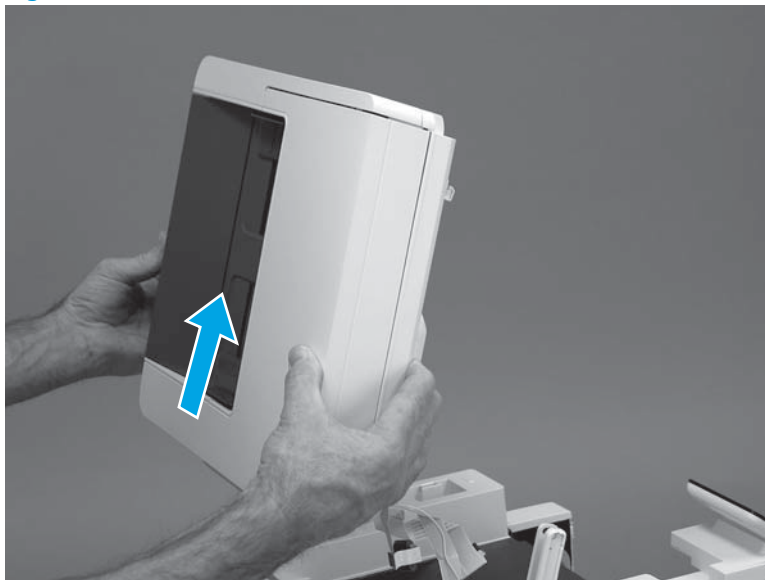

Step 6: Remove the control panel (M427/M246)

 **NOTE:** The step is for the M427/M426 printer. For the M403/M402, skip this step and go to [Step 8: Remove the top cover \(M403/M402\) on page 694](#).

- Disconnect one FFC (callout 1; J114), and then release the FFC from the retainer (callout 2).

Figure 1-1273 Disconnect one connector

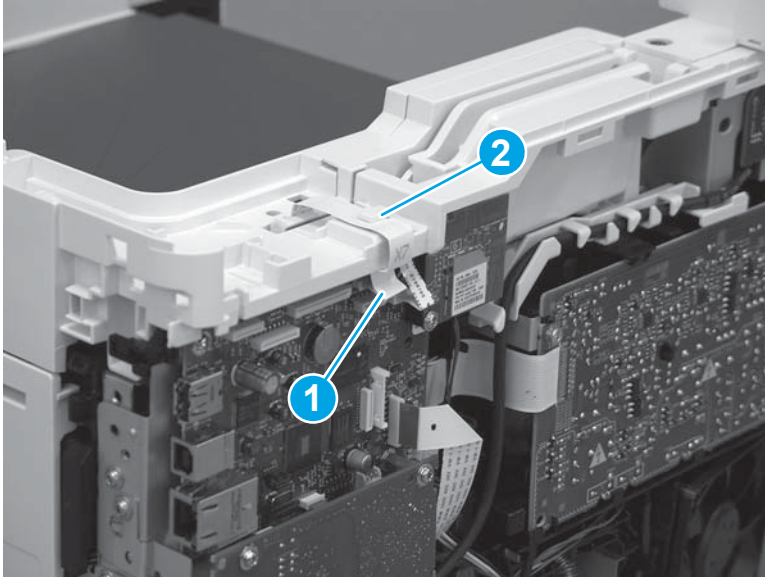

2. Remove one screw (callout 1).

Figure 1-1274 Remove one screw

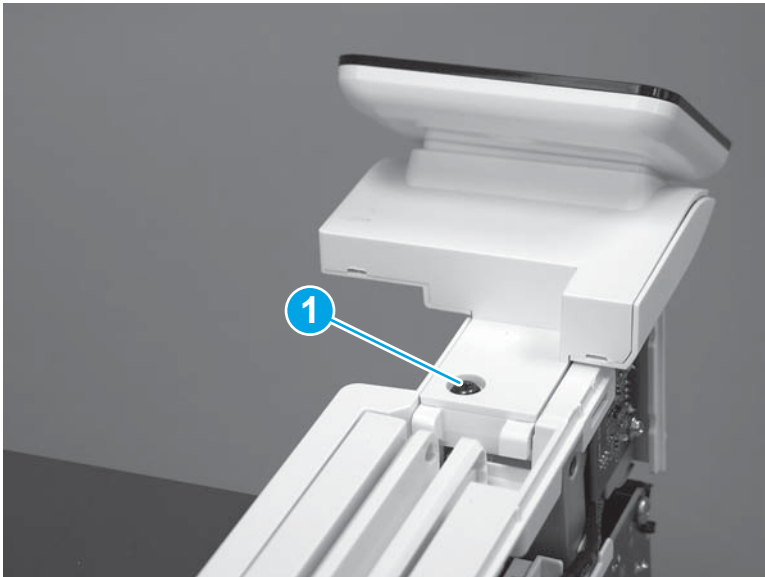

3. Use a small flat-blade screwdriver to release two tabs (callout 1) on the control-panel cable cover.

Figure 1-1275 Release two tabs

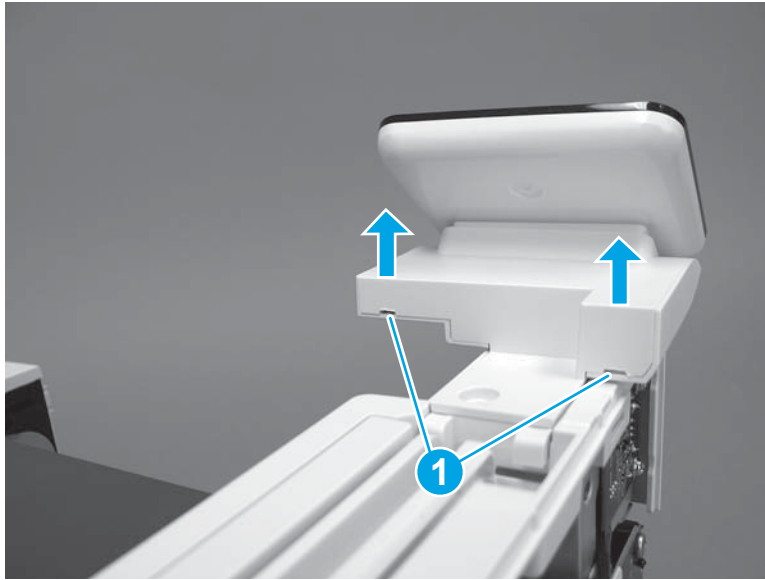

4. Remove the control-panel cable cover.

Figure 1-1276 Remove the cover

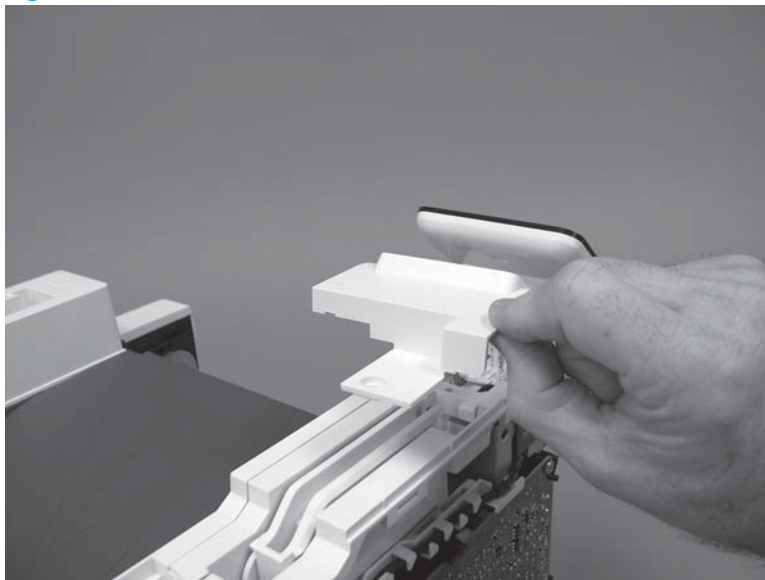

5. Remove one grounding screw (callout 1), and then move the ground cable (callout 2) out of the way.

Figure 1-1277 Remove one screw

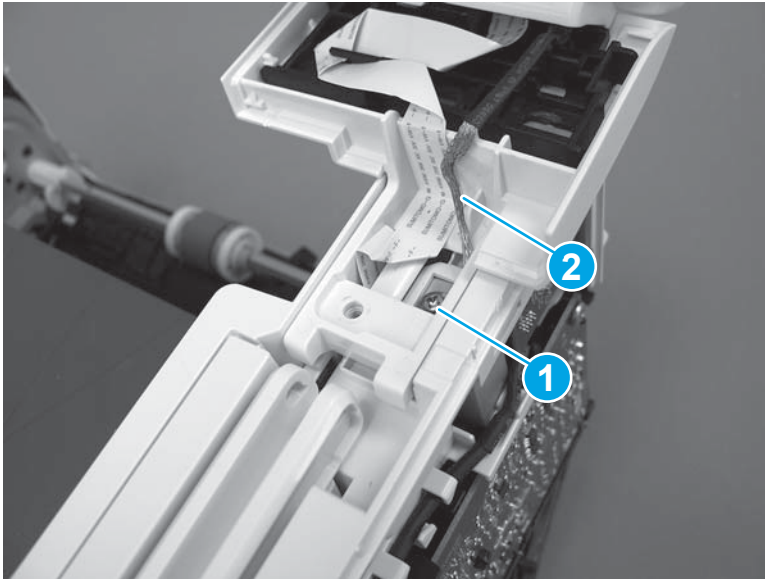

6. Move the FFC out of the way, and then remove two screws (callout 1).

Figure 1-1278 Remove two screws

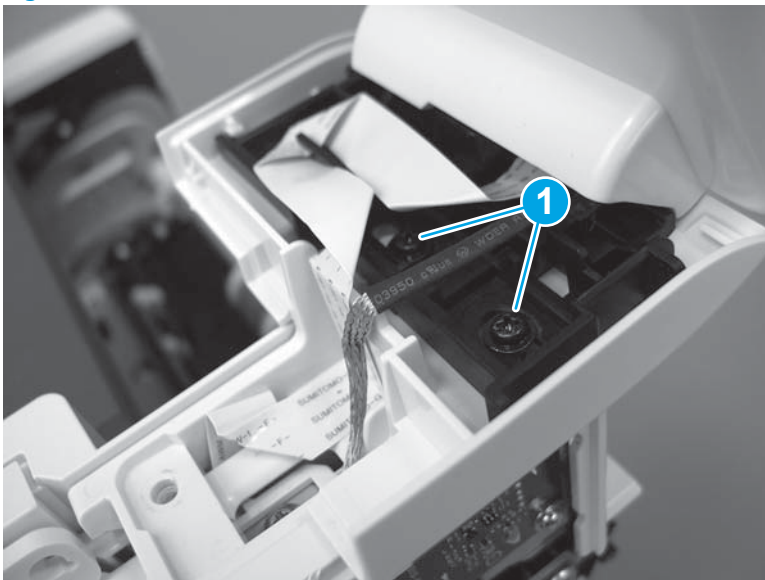

7. Slightly lift up the control-panel assembly to separate it from the top cover.

CAUTION: The control panel assembly is still connected to the printer by the FFC. Do not attempt to completely remove the assembly.

Figure 1-1279 Lift up the control-panel assembly

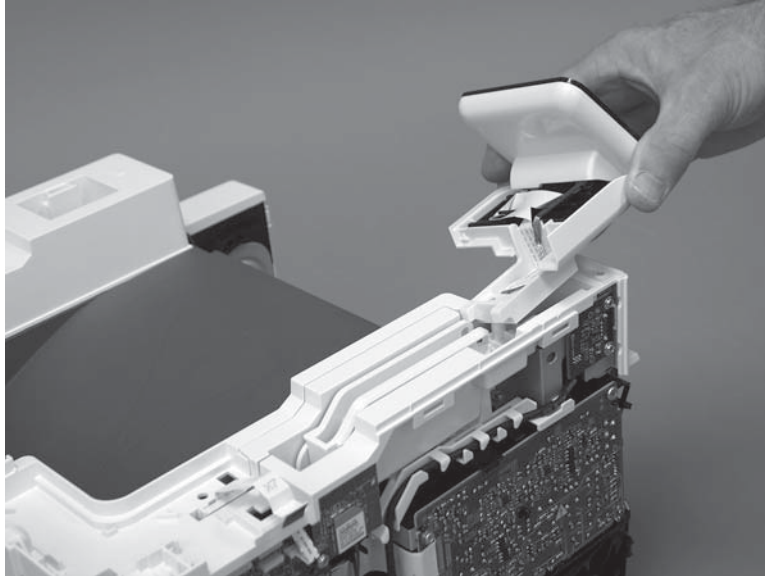

8. Lift up the control-panel FFC cover to remove the control-panel assembly.

Figure 1-1280 Remove the control-panel assembly

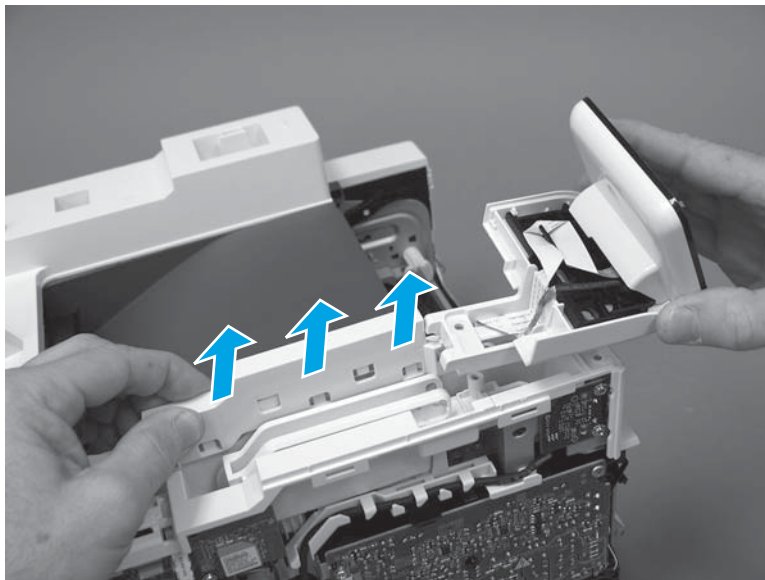

Step 7: Remove the top cover (M427/M426)

NOTE: The step is for the M427/M426 printer. For the M403/M402, skip this step and go to [Step 8: Remove the top cover \(M403/M402\) on page 694](#).

1. Release the USB cable (callout 1) from the cable guide.

Figure 1-1281 Remove the USB cable

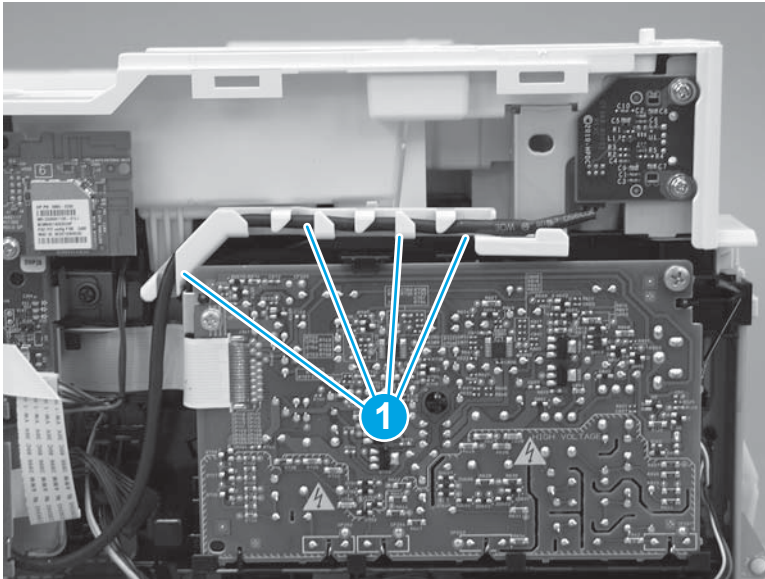

2. Remove five screws (callout 1), release four bosses (callout 2), and then remove the top cover (callout 3).

Figure 1-1282 Remove the cover

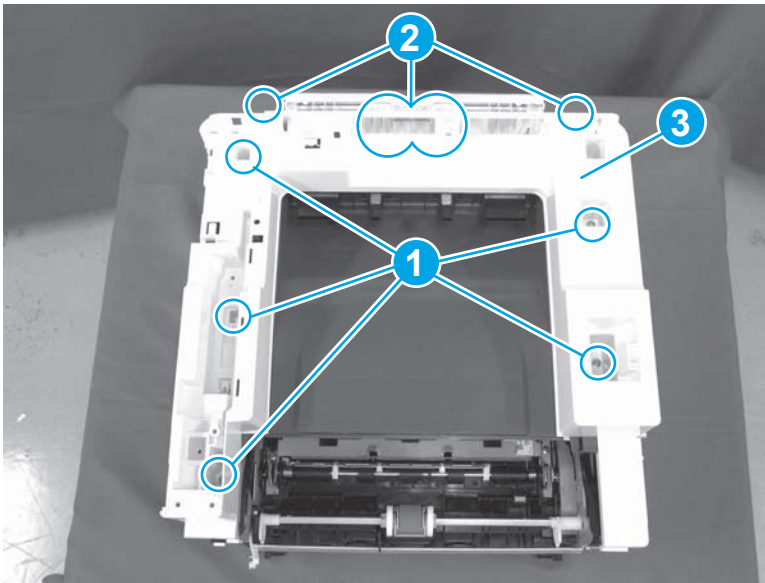

Step 8: Remove the top cover (M403/M402)

 **NOTE:** The step is for the M403/M402 printer. For the M427/M426, skip this step and go to [Step 9: Remove the sheet-metal formatter bracket and formatter PCA on page 696.](#)

1. Remove one screw (callout 1).

Figure 1-1283 Remove one screw



2. At the right side of the printer, release the one boss (callout 1), and then release one tab (callout 2).

Figure 1-1284 Release one boss and one tab

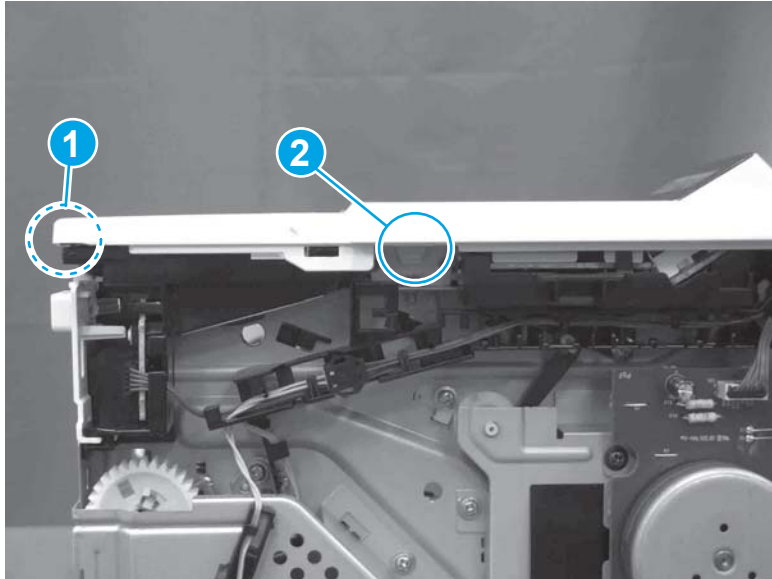

3. Release four tabs (callout 1), release four bosses (callout 2), and then remove the top cover (callout 3).



 **TIP:** Open the rear door to make releasing the bosses (callout 3) easier.

Figure 1-1285 Remove the cover

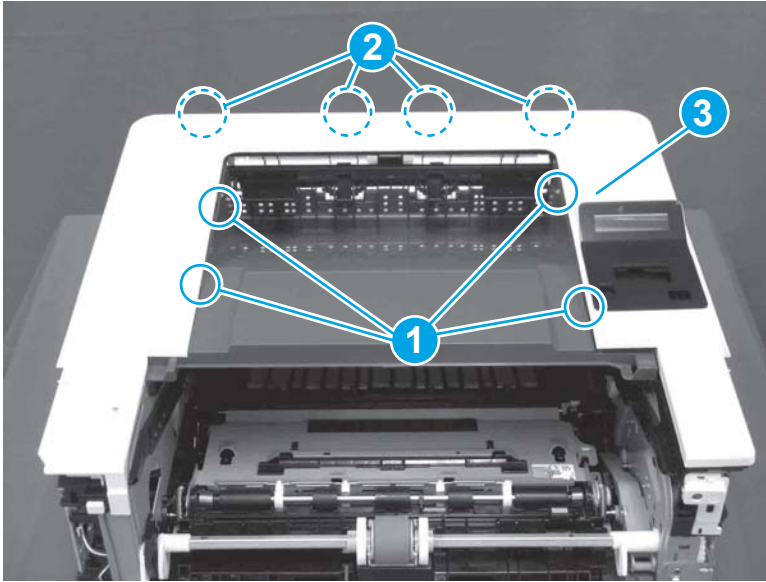

Step 9: Remove the sheet-metal formatter bracket and formatter PCA

 **NOTE:** Disconnect any remaining formatter PCA FFCs or wire-harness connectors.

1. **M427/M426 only:** Remove the guide (callout 1).

Figure 1-1286 Remove the guide

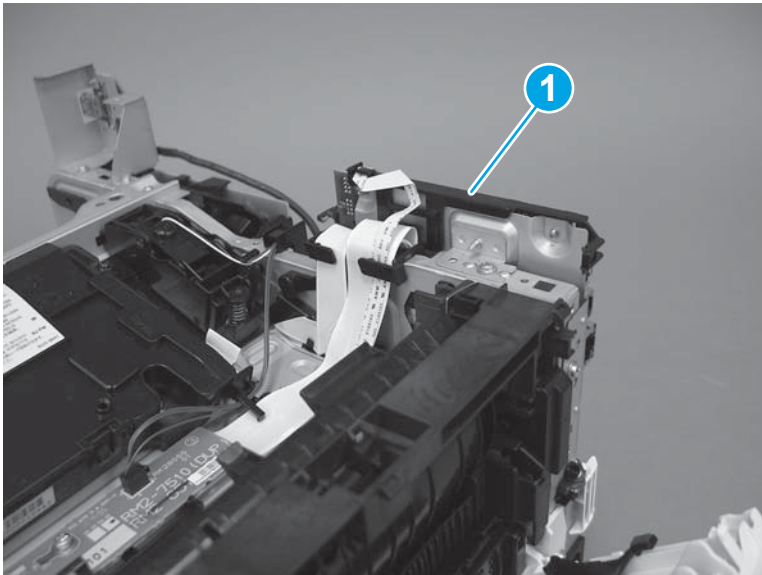

2. Remove two screws (callout 1).

Figure 1-1287 Remove two screws

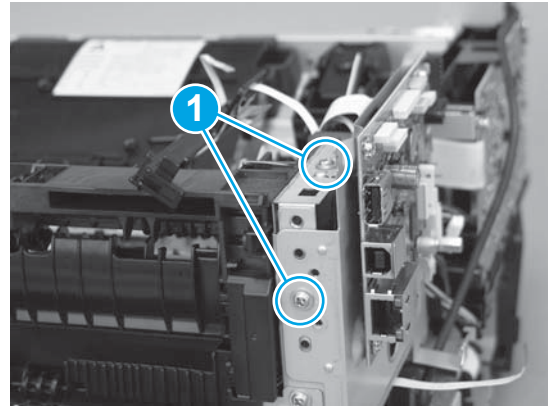
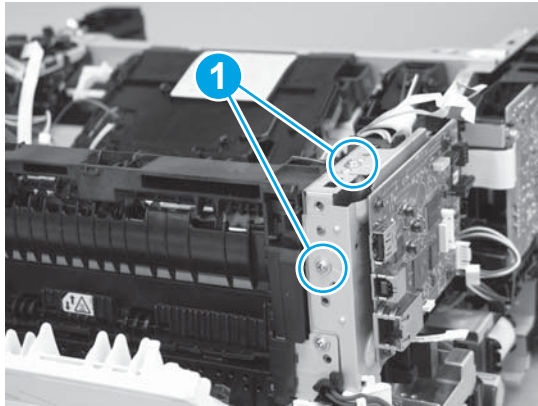

3. Disconnect one connector (callout 1), and then release the wire harness from the guide (callout 2).

Figure 1-1288 Disconnect one connector

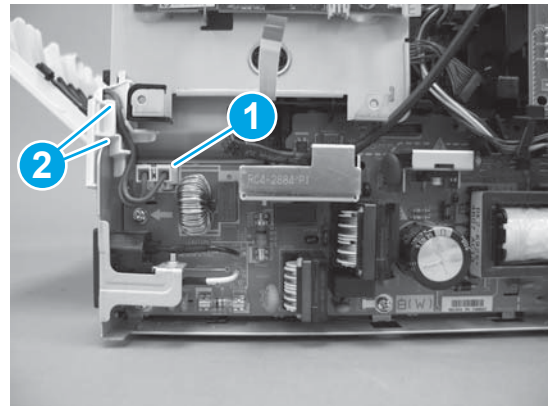
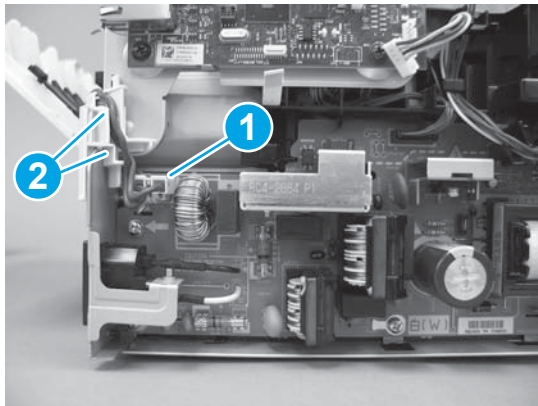

4. Remove the guide (callout 1).

Figure 1-1289 Remove the guide

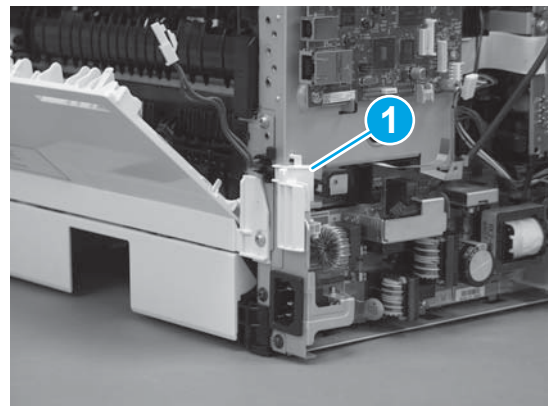
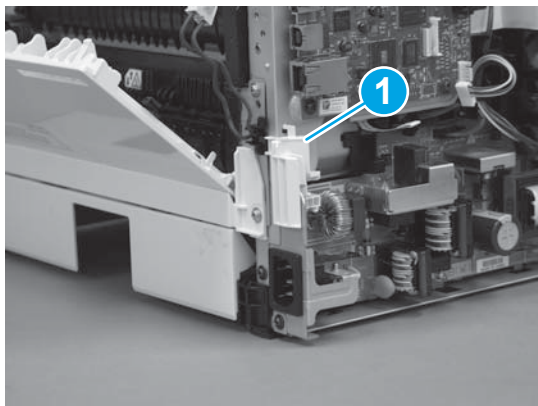

5. Remove three screws (callout 1).

Figure 1-1290 Remove three screws

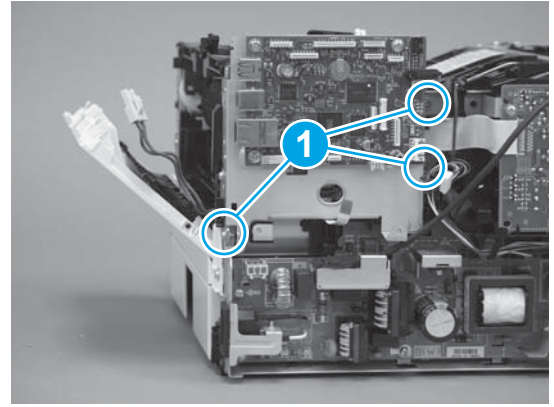
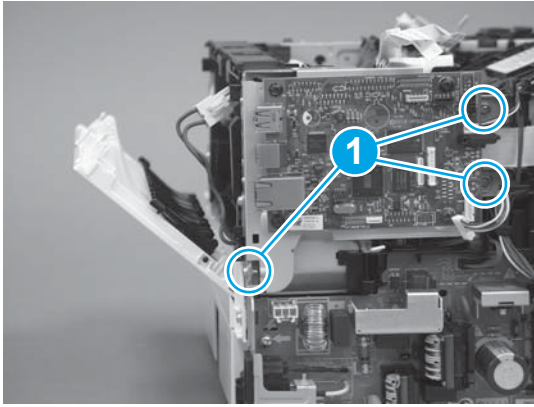

6. Remove the sheet-metal bracket and formatter PCA.

Figure 1-1291 Remove the bracket

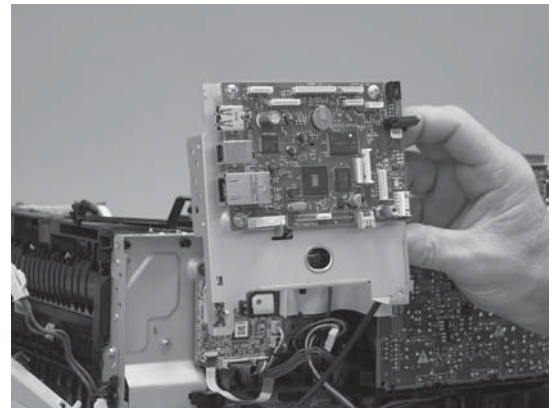
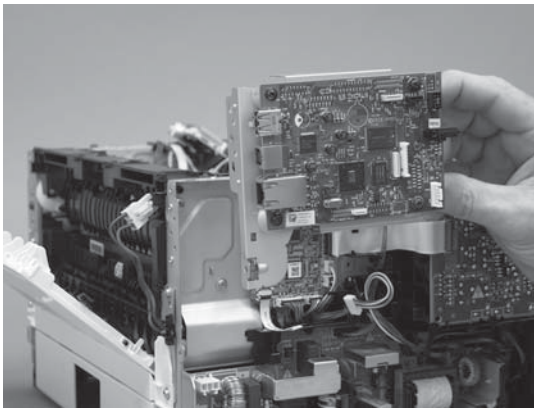

Step 10: Remove the formatter FFC

1. Carefully pull up on the FFC (callout 1) to release it from the guide—the FFC is attached to the guide with two-sided tape.

CAUTION: The FFC is still attached to the DC controller. Do not attempt to completely remove the FFC.

Figure 1-1292 Release the FFC

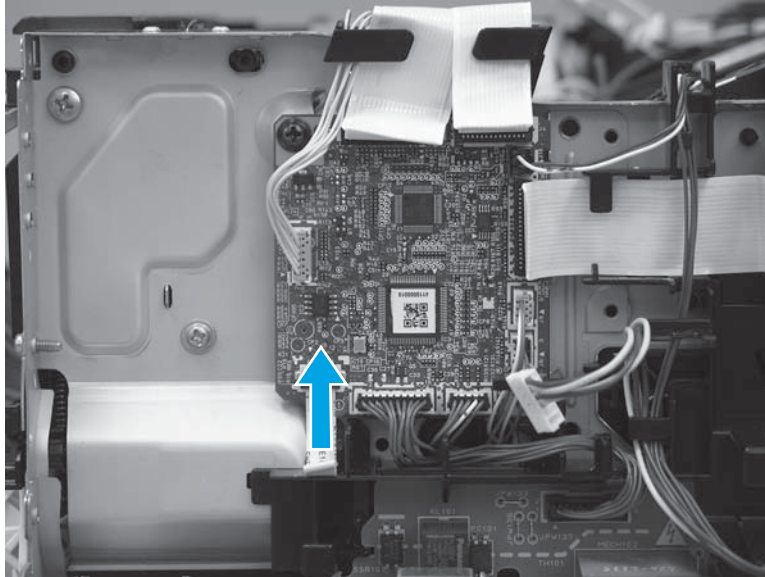

2. Disconnect the formatter FFC (callout 1).

 **IMPORTANT:** The FFC connector (callout 2) is a Zero Insertion Force (ZIF) connector that uses a hinged retainer to secure the FFC. The hinged retainer must be opened to release the FFC.

Figure 1-1293 Disconnect the FFC



Step 11: Unpack the replacement assembly

Unpack the replacement part from the packaging.

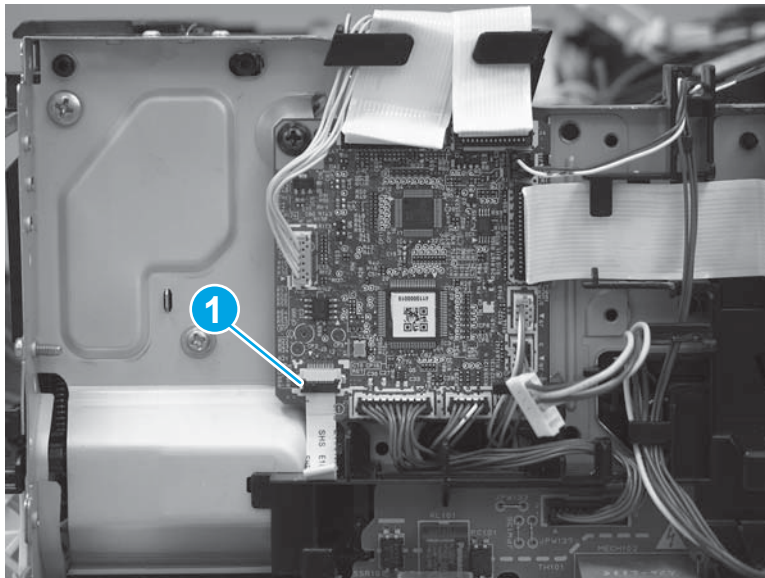
<http://www8.hp.com/us/en/hp-information/environment/product-recycling.html>

 **NOTE:** HP recommends responsible disposal of the defective part.

Figure 1-1294 Recycle and unpack

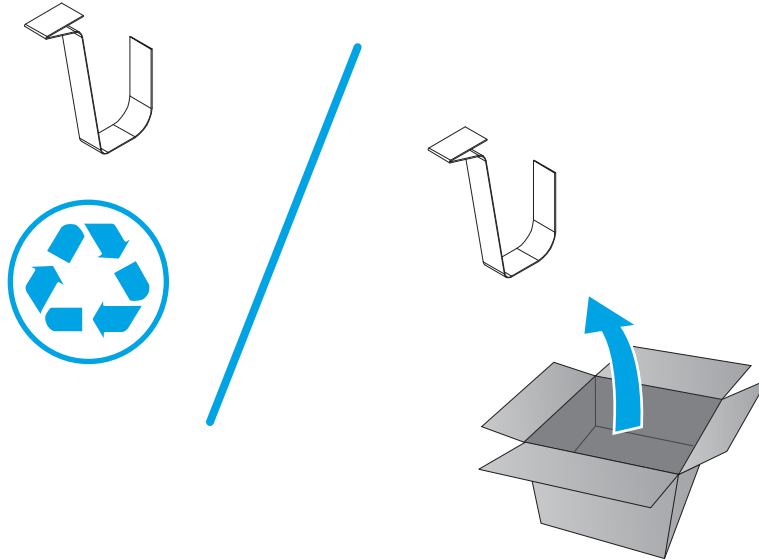

Step 12: Install the formatter FFC

1. Connect the formatter FFC (callout 1) to the DC controller connector (callout 2).

Make sure that the FFC is fully inserted into the connector body, close the hinged retainer to lock the cable in place, and then slightly tug on the cable to make sure it is securely fastened.

 **IMPORTANT:** The ZIF connector hinged retainer must be in the open position to insert the FFC.

 **Reinstallation tip:** The pre-fold end of the FFC will connect to the formatter PCA.

Figure 1-1295 Connect one the FFC



2. Carefully push on the FFC (callout 1) to adhere it to the guide.

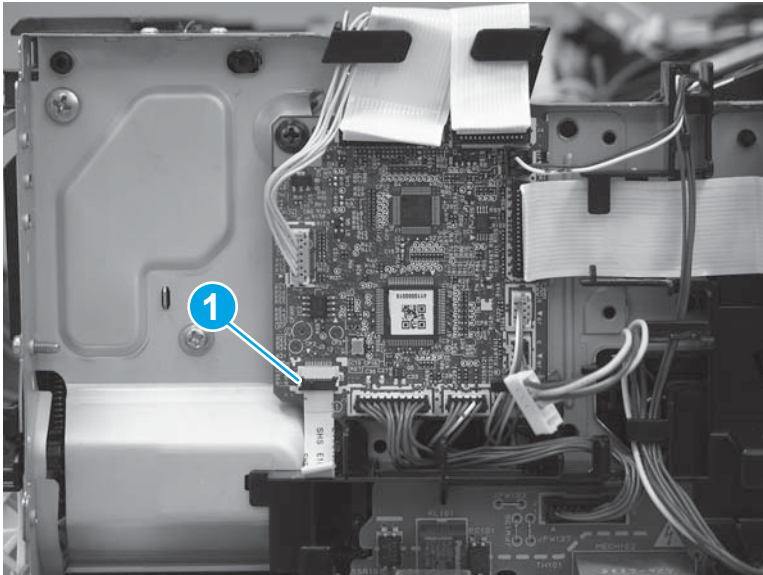

 **Reinstallation tip:** Use the discarded FFC as a guide to apply a small section of two-sided tape to the replacement FFC.

Figure 1-1296 Adhere the FFC to the guide

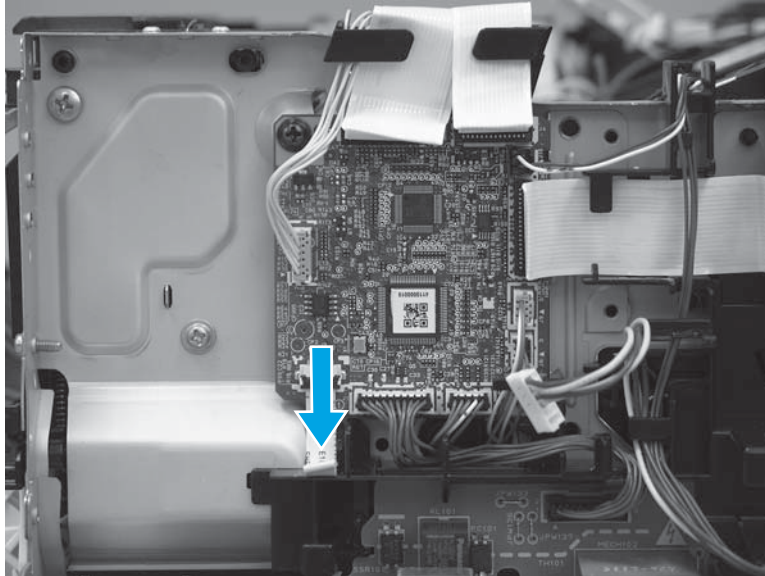

Step 13: Install the sheet-metal formatter bracket and formatter PCA

 **NOTE:** Do not forget to connect any formatter PCA FFCs or wire-harness connectors that were disconnected when the bracket was removed.

1. Position the sheet-metal bracket and formatter PCA on the printer.

Figure 1-1297 Install the bracket

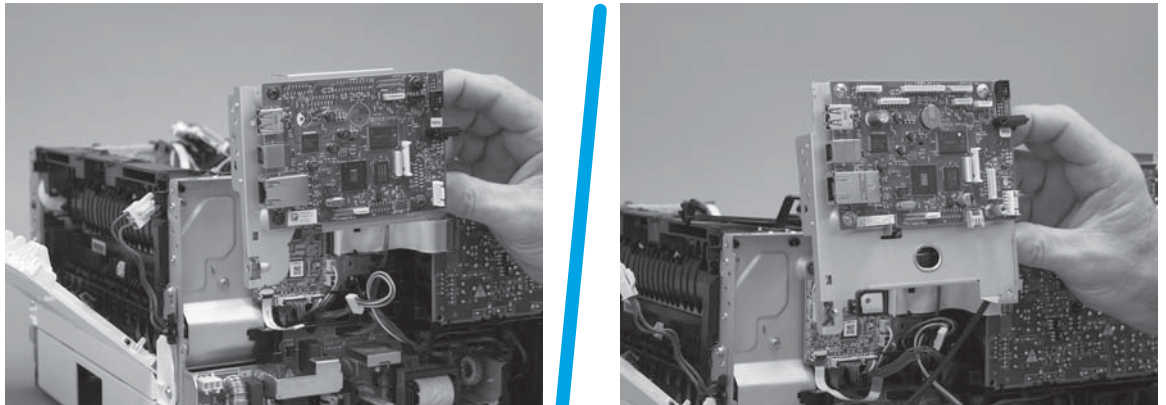

2. Install three screws (callout 1).

Figure 1-1298 Install three screws

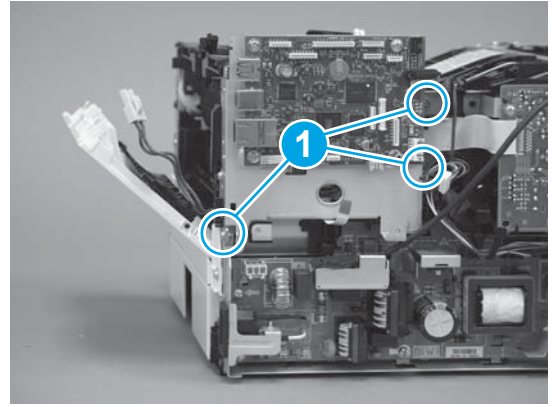
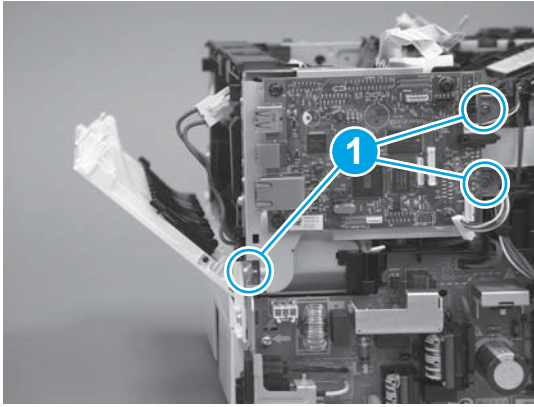

3. Install the guide (callout 1).

Figure 1-1299 Install the guide

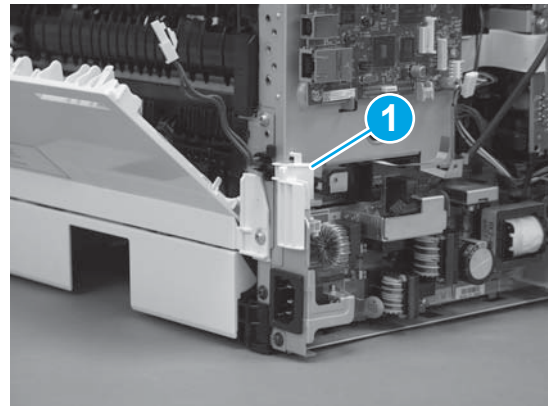
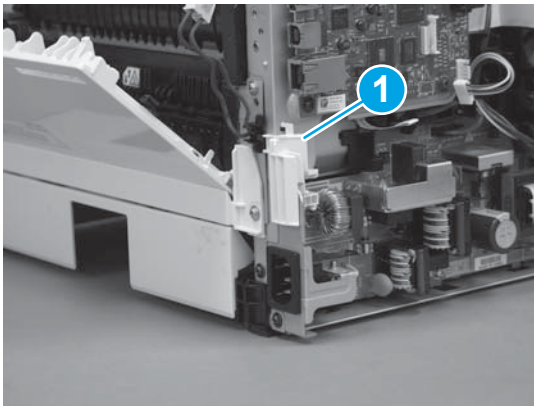

4. Connect one connector (callout 1), and then install the wire harness in the guide (callout 2).

Figure 1-1300 Connect one connector

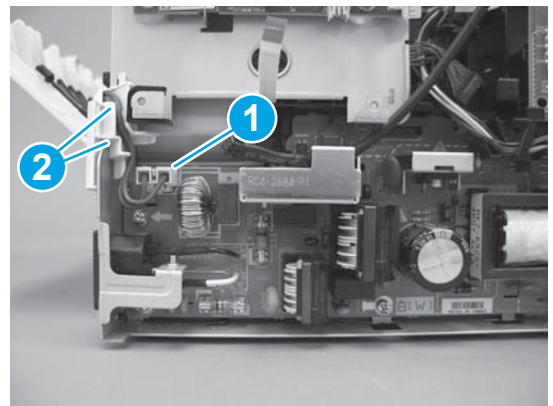
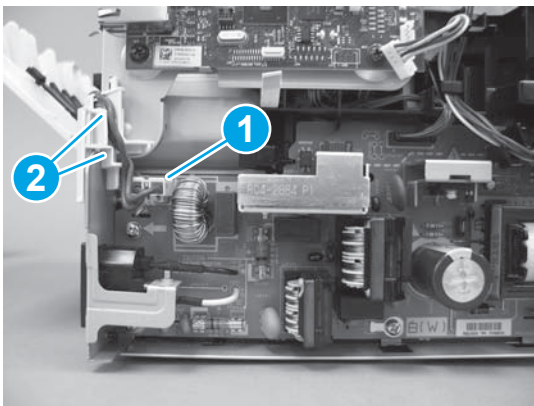

5. Install two screws (callout 1).

Figure 1-1301 Install two screws

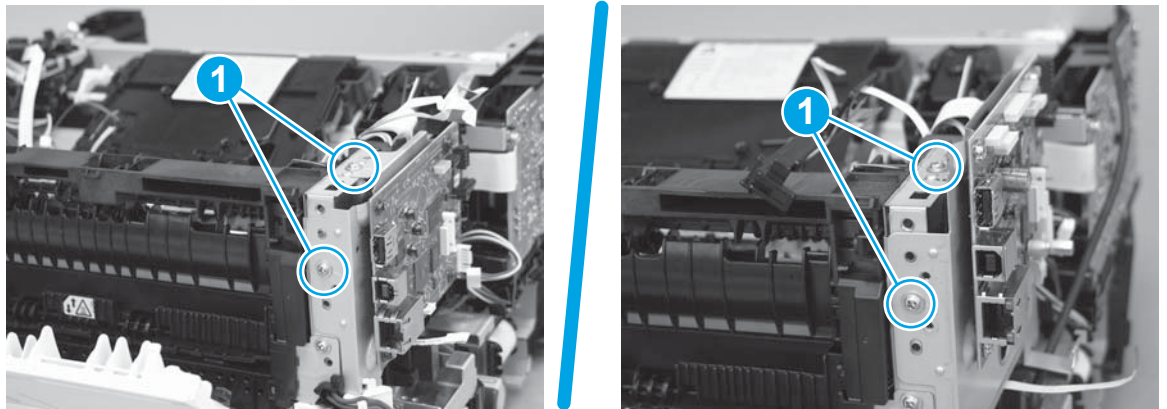

6. **M427/M426 only:** Install the guide (callout 1).

Figure 1-1302 Install the guide

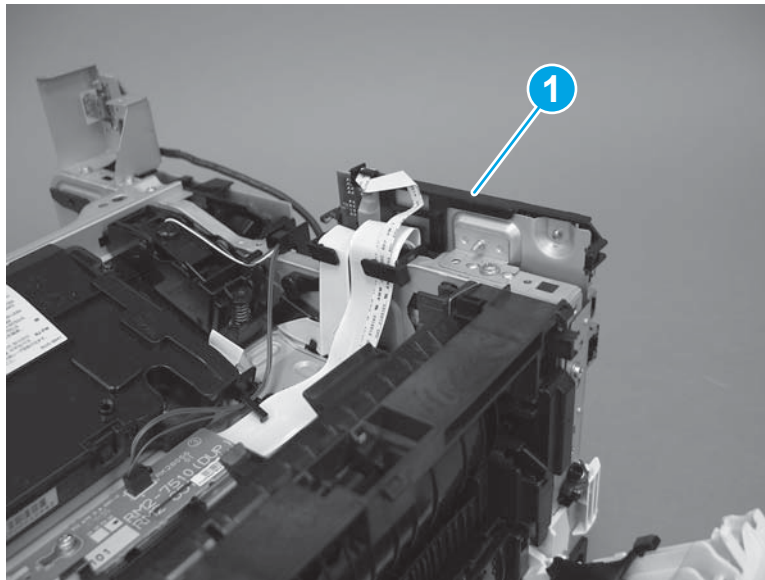

Step 14: Install the top cover (M403/M402)

 **NOTE:** The step is for the M403/M402 printer. For the M427/M426, skip this step and go to [Step 15: Install the top cover \(M427/M426\) on page 705](#).

1. Position the rear edge of the cover on the printer.

Figure 1-1303 Install the cover

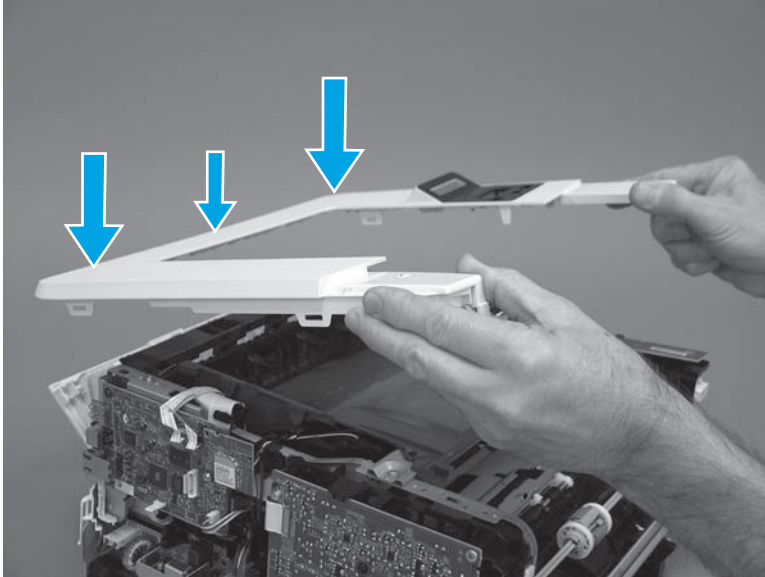

2. Engage four bosses (callout 1), rotate the front of the cover down (callout 2) and onto from the printer, and then engage four tabs (callout 3).

Figure 1-1304 Engage four bosses and tabs

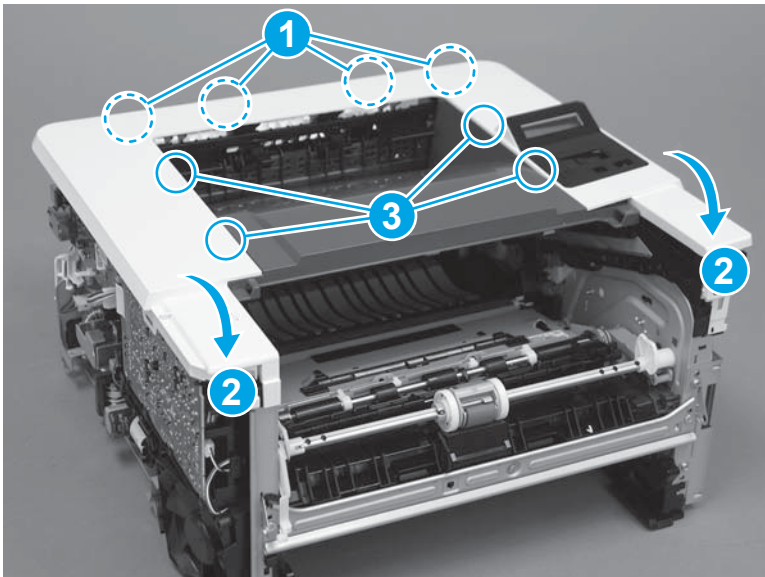

3. At the right side of the printer, engage the one boss and one tab (callout 1).

Figure 1-1305 Engage one boss and one tab

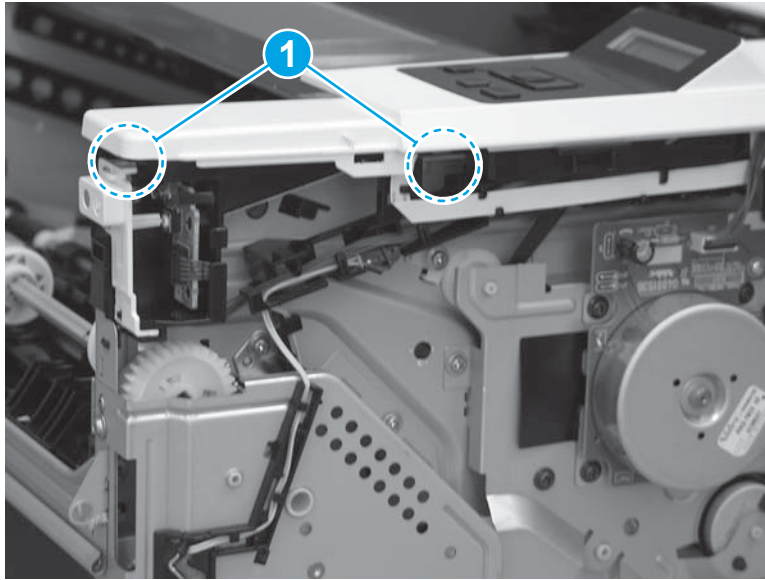

4. Install one screw (callout 1).

Figure 1-1306 Install one screw



Step 15: Install the top cover (M427/M426)

 **NOTE:** The step is for the M427/M426 printer. For the M403/M402, skip this step and go to [Step 18: Install the right cover on page 717](#).

1. Position the rear edge of the top cover on the printer.

Figure 1-1307 Install the cover

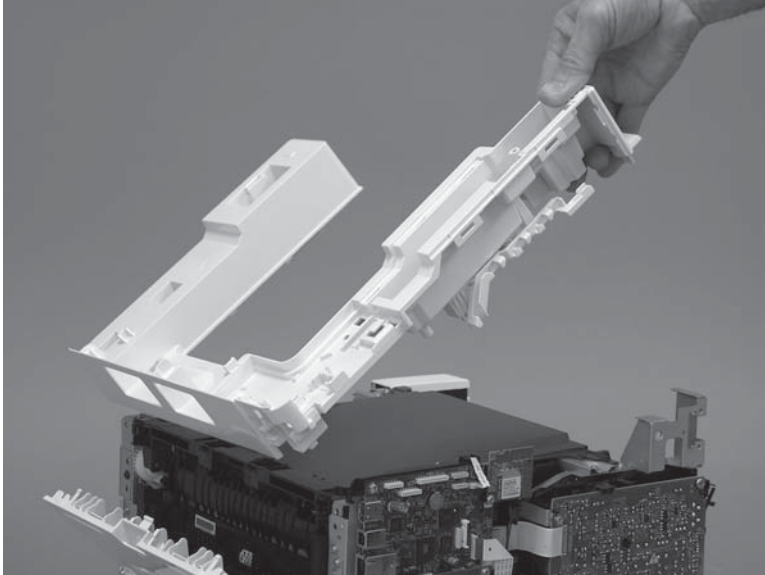

2. Engage four bosses (callout 1).

Figure 1-1308 Engage four bosses

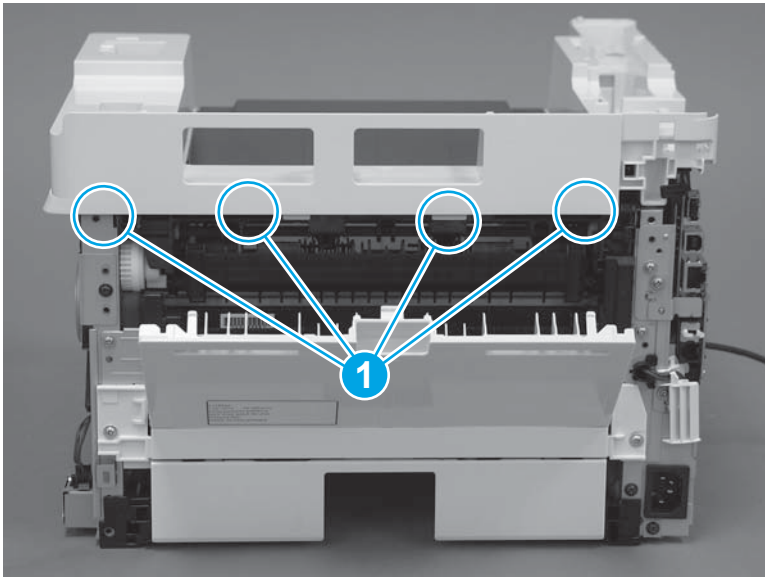

3. Rotate the front edge of the cover down.

Figure 1-1309 Rotate the front edge of the cover down

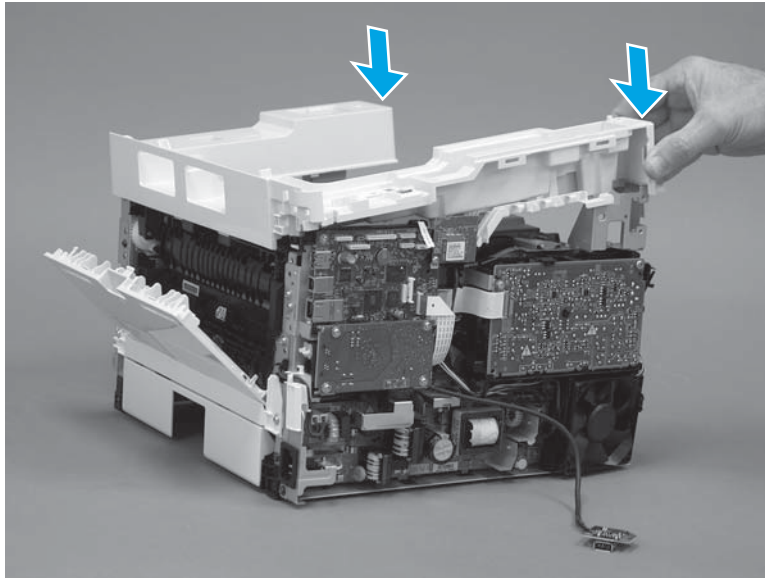

4. Install the USB cable (callout 1) in the guide.

Figure 1-1310 Install the USB PCA

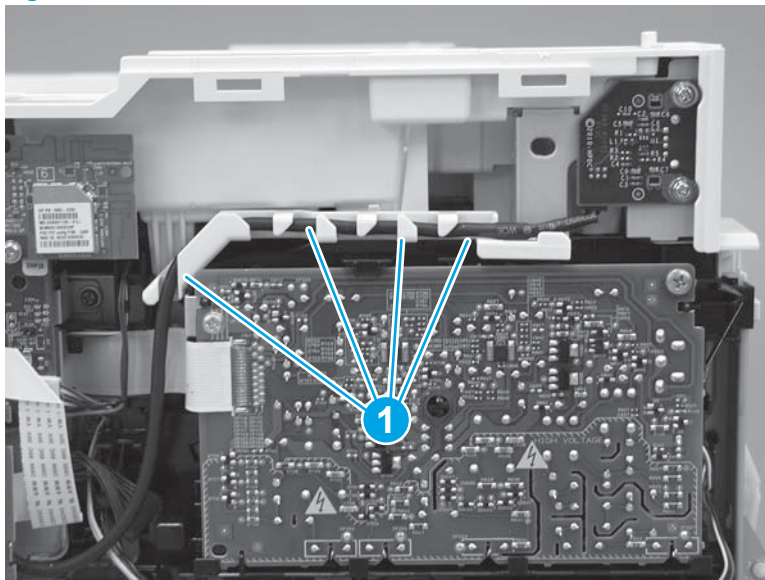

5. Install five screws (callout 1).

Figure 1-1311 Install five screws

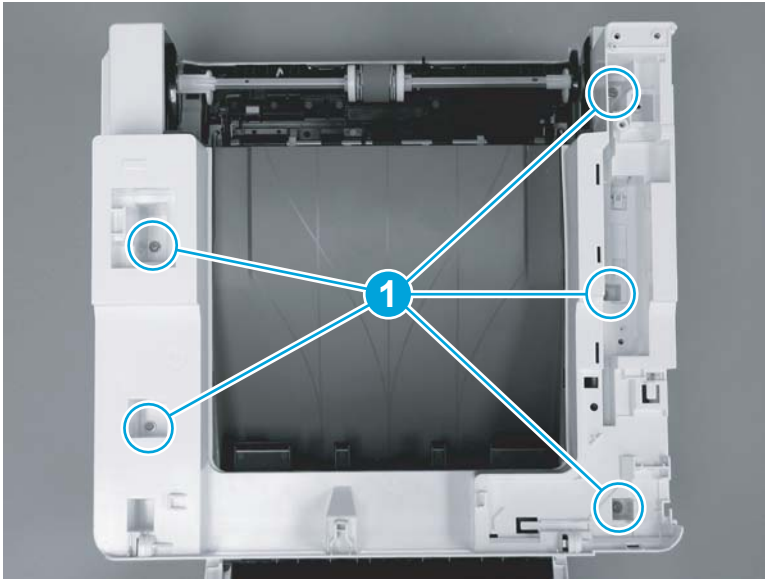

Step 16: Install the control panel (M427/M246)

 **NOTE:** The step is for the M427/M426 printer. For the M403/M402, skip this step and go to [Step 18: Install the right cover on page 717](#).

1. Slide the control-panel FFC cover into the slot in the top cover (next to the document feeder support arm) to install it.

Figure 1-1312 Install the control-panel FFC cover

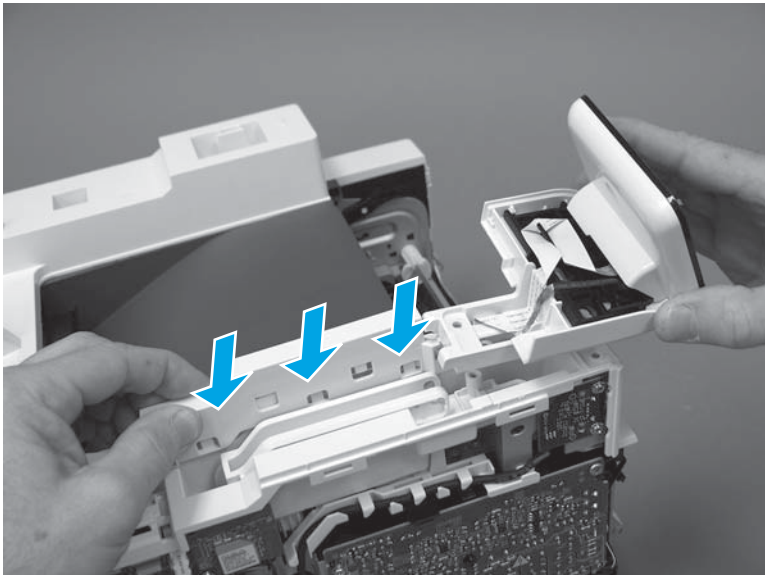

2. Install the control-panel assembly on the top cover.

Figure 1-1313 Install the control-panel assembly

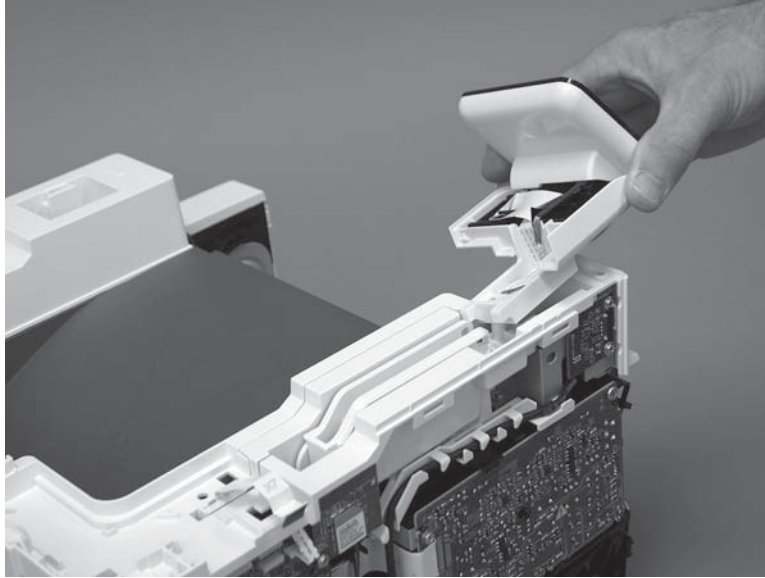

3. Move the FFC out of the way, and then install two screws (callout 1).

Figure 1-1314 Install two screws

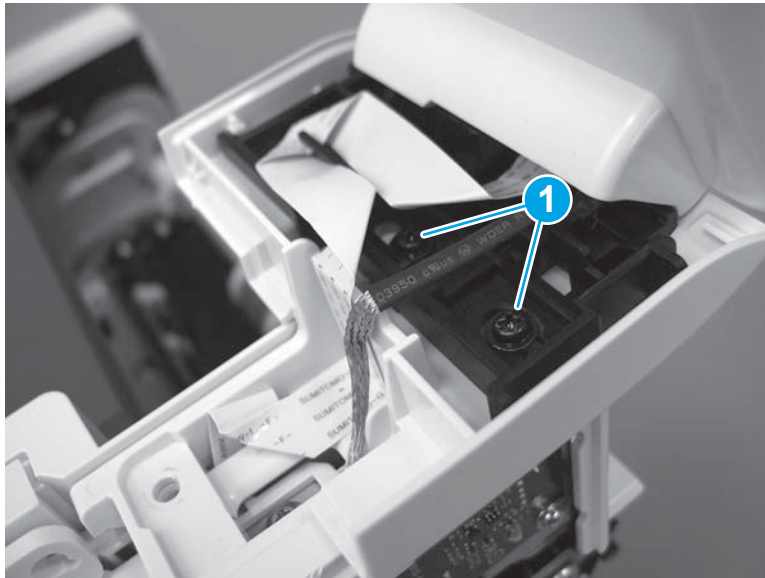

4. Install one grounding screw (callout 1), and then make sure that the ground cable (callout 2) is properly routed.

Figure 1-1315 Remove one screw

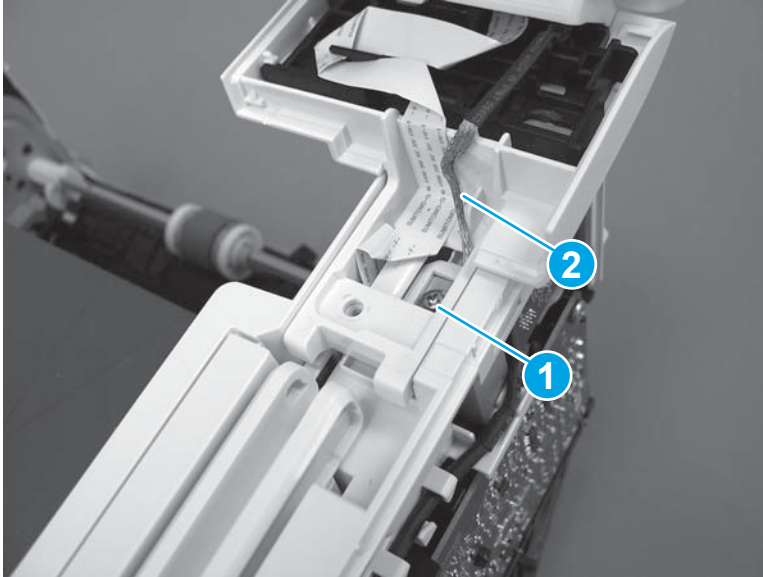

5. Install the control-panel cable cover.

Figure 1-1316 Install the cover

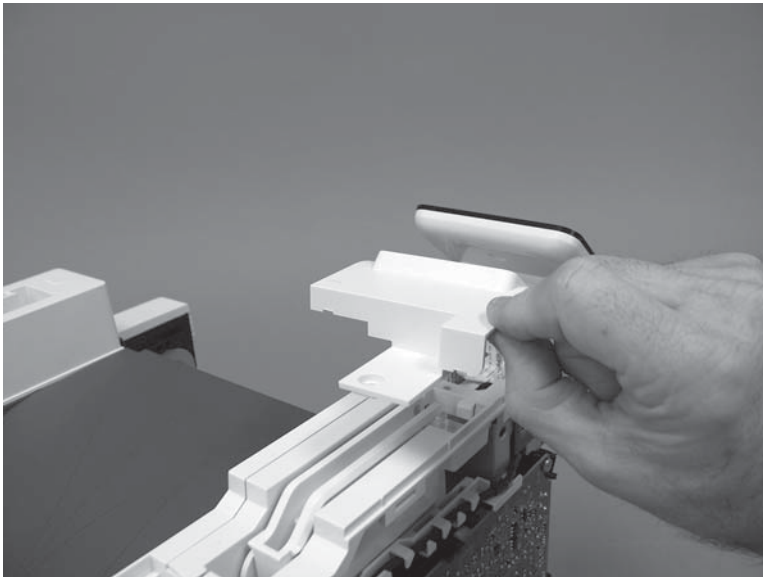

6. Make sure that the two tabs (callout 1) on the cover snap into place.

Figure 1-1317 Engage two tabs

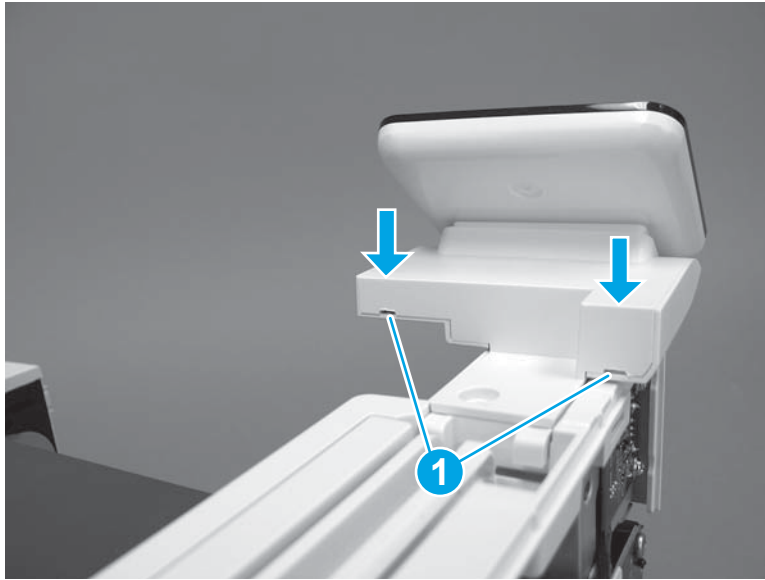

7. Install one screw (callout 1).

Figure 1-1318 Install one screw

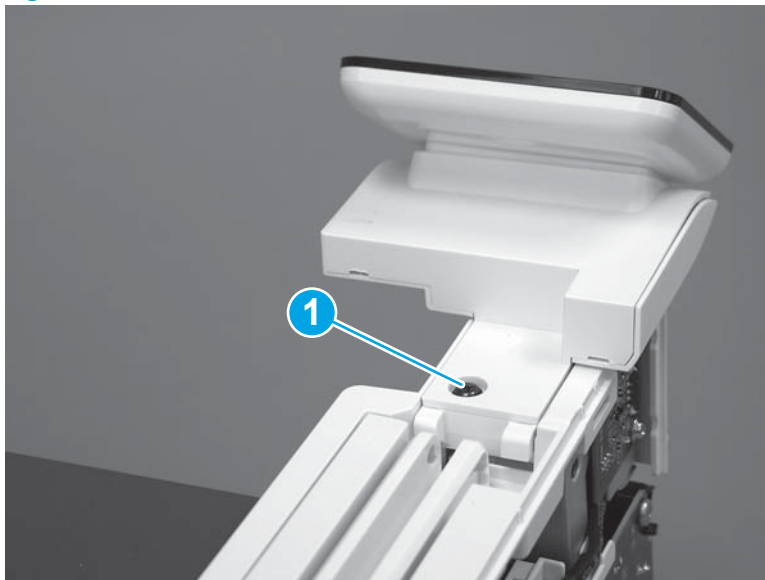

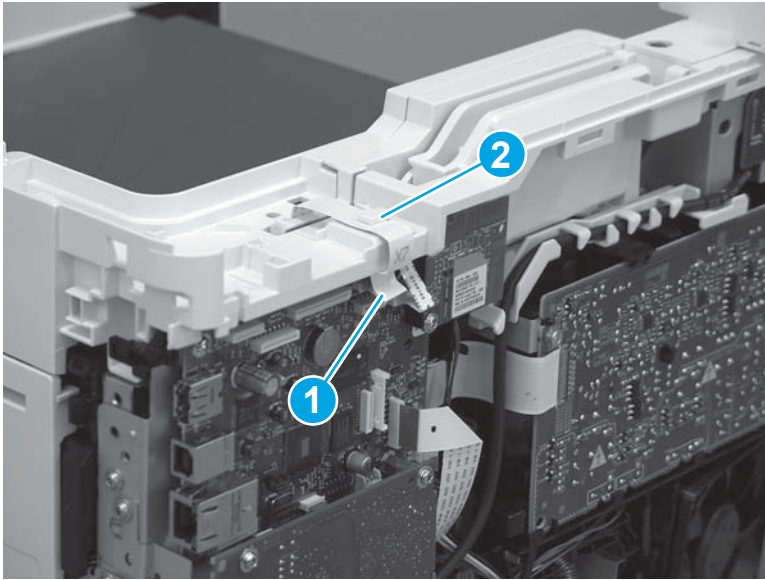

8. Install the FFC in the retainer (callout 1), and then connect one FFC (callout 1; J114).

Figure 1-1319 Connect one connector



Step 17: Install the integrated scanner assembly (M427/M246)

 **NOTE:** The step is for the M427/M426 printer. For the M403/M402, skip this step and go to [Step 18: Install the right cover on page 717](#).

 **NOTE:** M427/M426 models only. The integrated scanner assembly (ISA) includes the sub-scanner assembly (SSA) and the automatic document feeder (ADF).

1. Position the ISA on the printer.

Figure 1-1320 Position the ISA on the printer

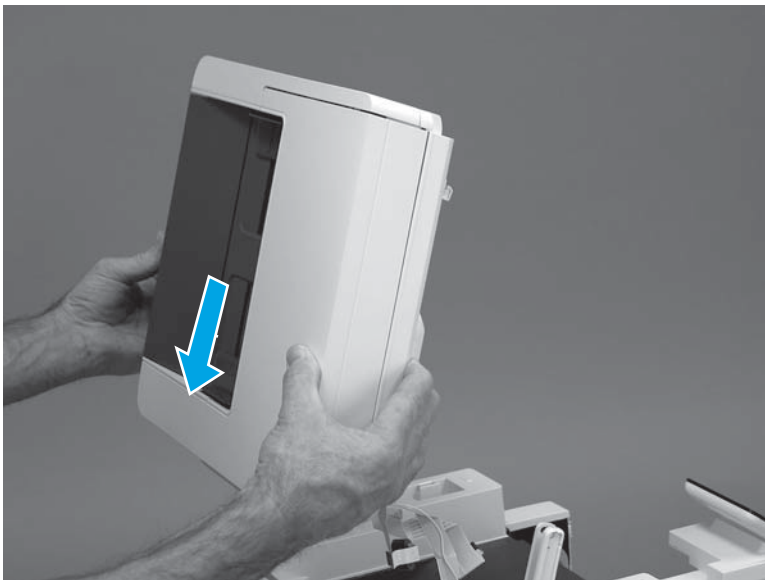

2. Engage the hinge pins on the ISA with the holders in the top cover (callouts 1/2), and then slide the ISA as shown to engage them

Figure 1-1321 Engage the hinge pins with the holders

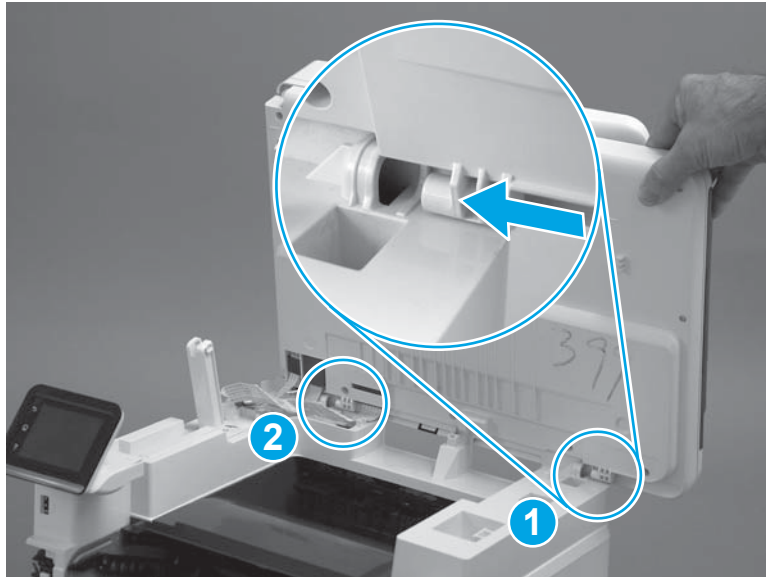

3. Rotate the ISA towards the front of the printer until it rests on the ISA lift assembly (callout 1).

Figure 1-1322 Rotate the ISA towards the front of the printer



4. Pass the ground wire through the opening in the top cover.

Figure 1-1323 Pass the wire through the opening

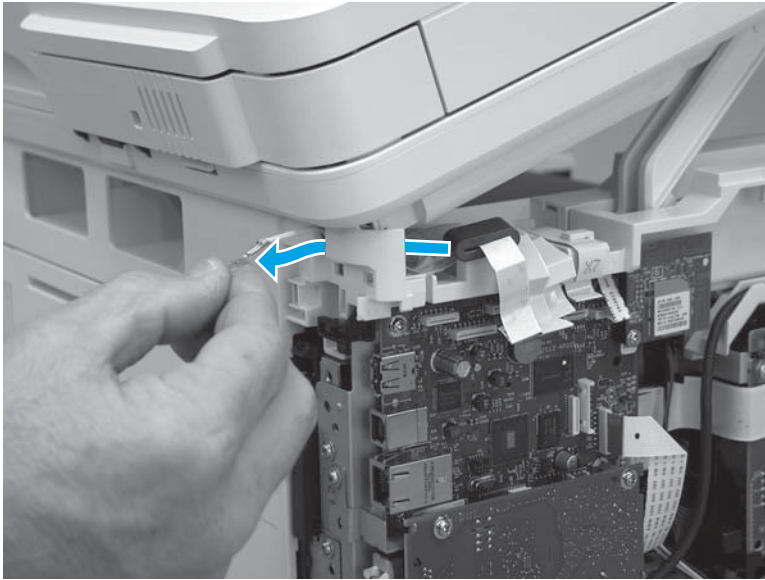

5. Install one screw (callout 1).

Figure 1-1324 Install one screw

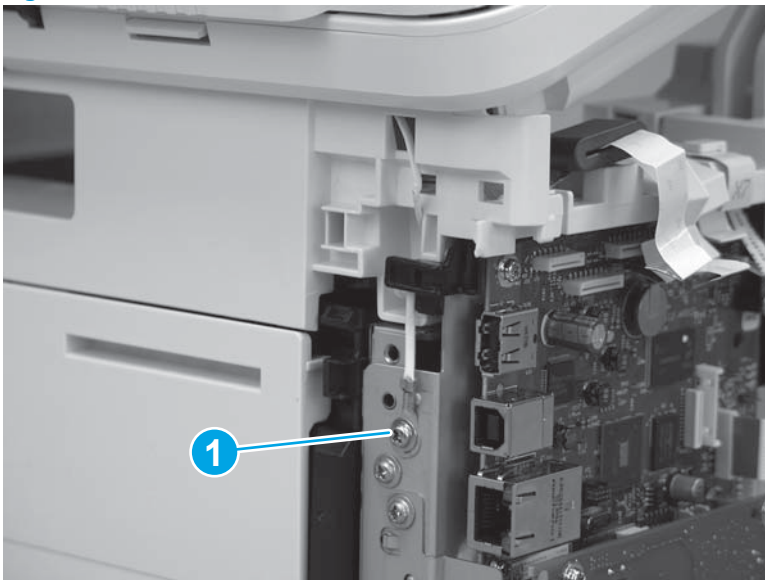

6. Install the ISA lift assembly slider pin.

 **Reinstallation tip:** Align the keyed portion of the locking pin with the slot and hole in the support arm.

Figure 1-1325 Install the slider pin



7. Rotate the slider pin (callout 1) towards the rear of the printer until the tab (callout 2) snap into place.

Figure 1-1326 Secure the slider pin

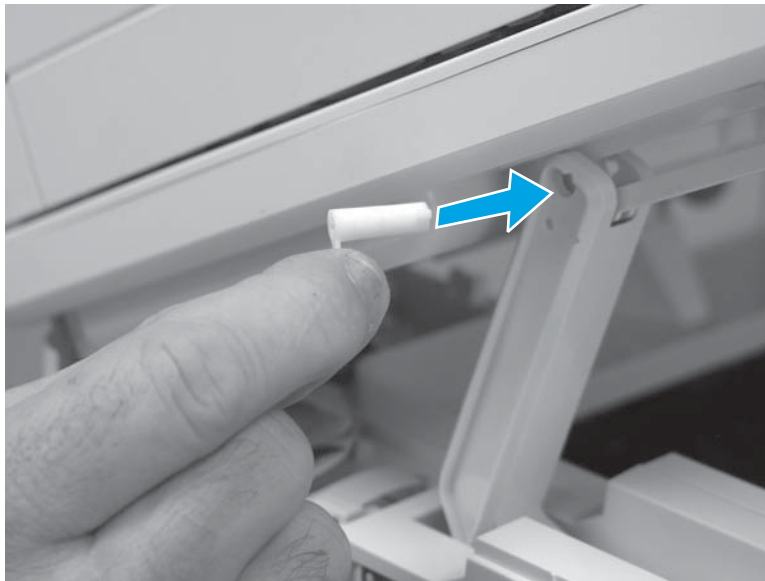
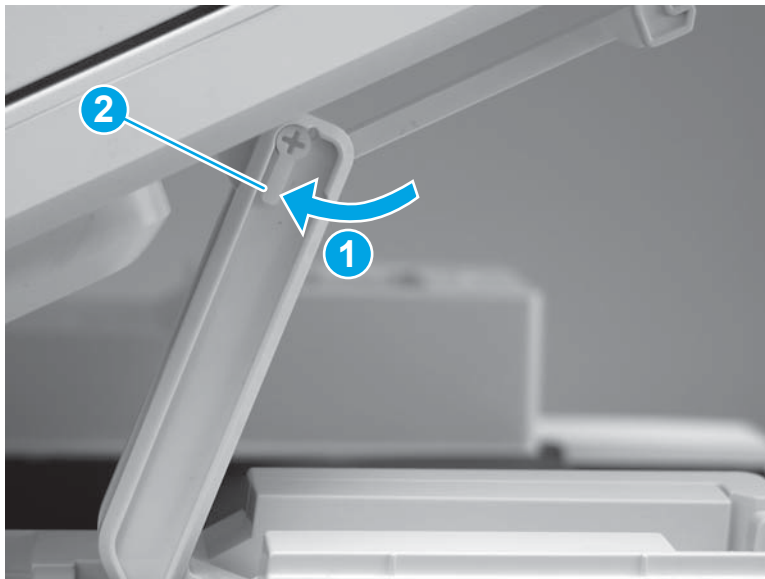

8. Install the ferrite (callout 1) in the holder, and then connect three FFCs (callout 2).

Figure 1-1327 Connect three FFCs

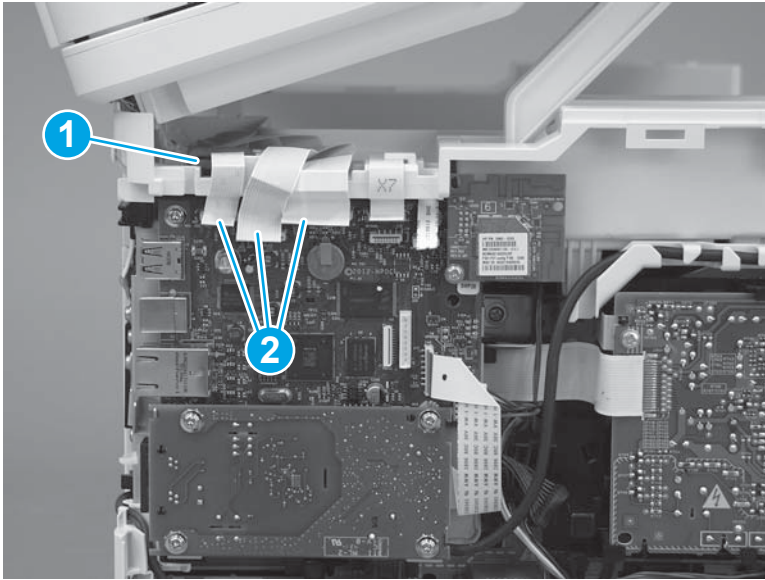

9. Position the rear edge of the ISA flat-flexible cable (FFC) cover on the printer (callout 1), and then rotate it down (callout 2) until it snaps into place.

Figure 1-1328 Install the ISA FFC cover

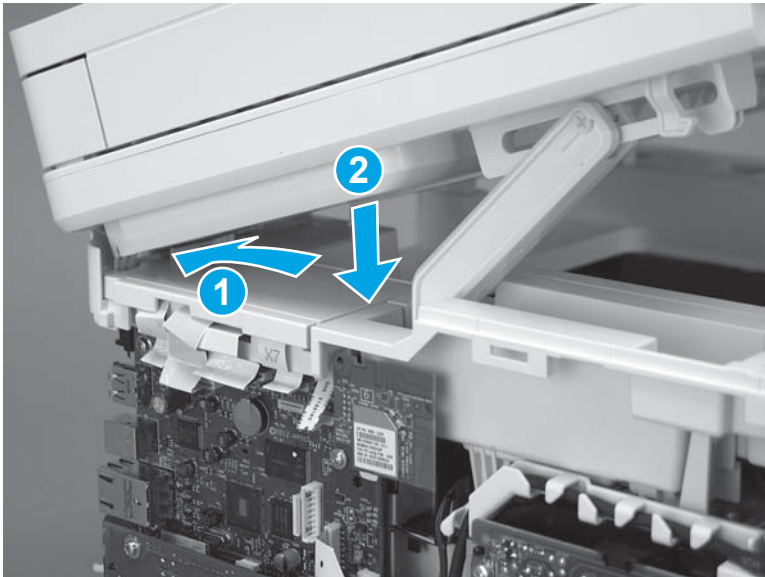

10. Lower the ISA.

Figure 1-1329 Lower the ISA

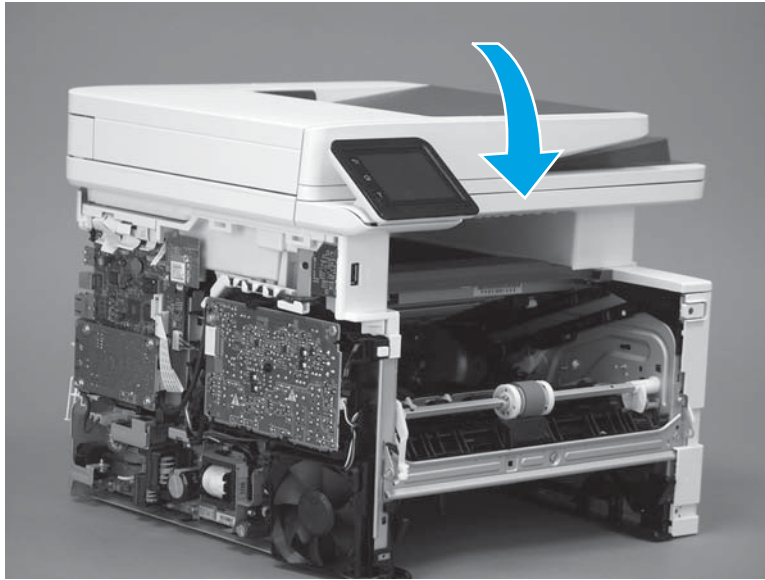

Step 18: Install the right cover

1. Position the cover (callout 1) on the printer, and then engage two bosses (callout 2).

Figure 1-1330 Install the cover

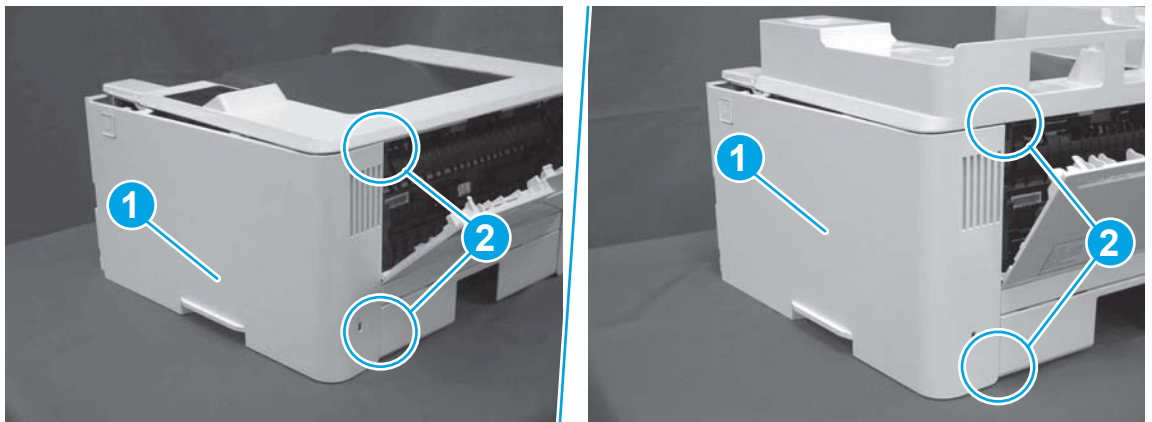

2. Rotate the front of the cover onto the printer (callout 1), engage three (callout 2) tabs, and then engage two bosses (callout 3).

Figure 1-1331 Engage two bosses and one tab

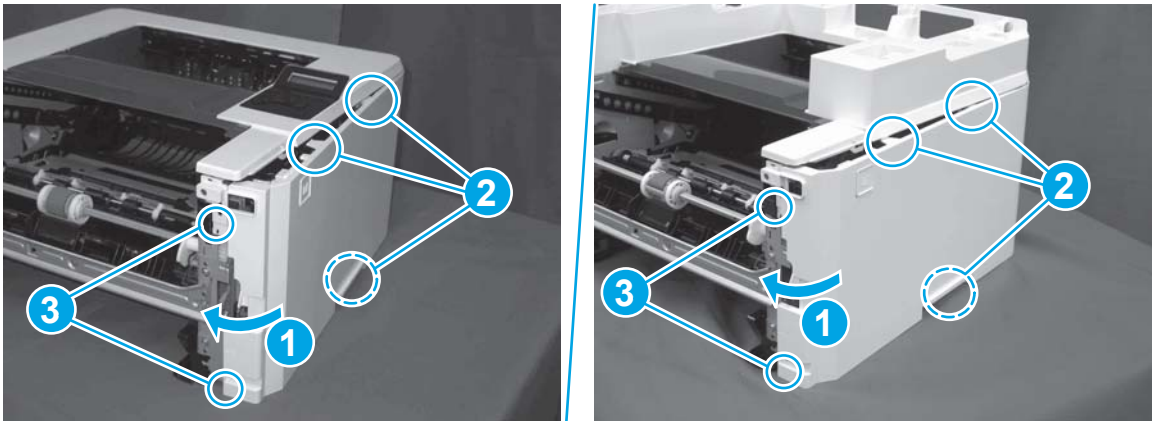

3. Make sure that the power switch (callout 1) and cartridge door assembly button (callout 2) correctly function.



NOTE: Remove, and then reinstall the cover if the switch or button does not correctly function.

Figure 1-1332 Check the power switch and cartridge door assembly button

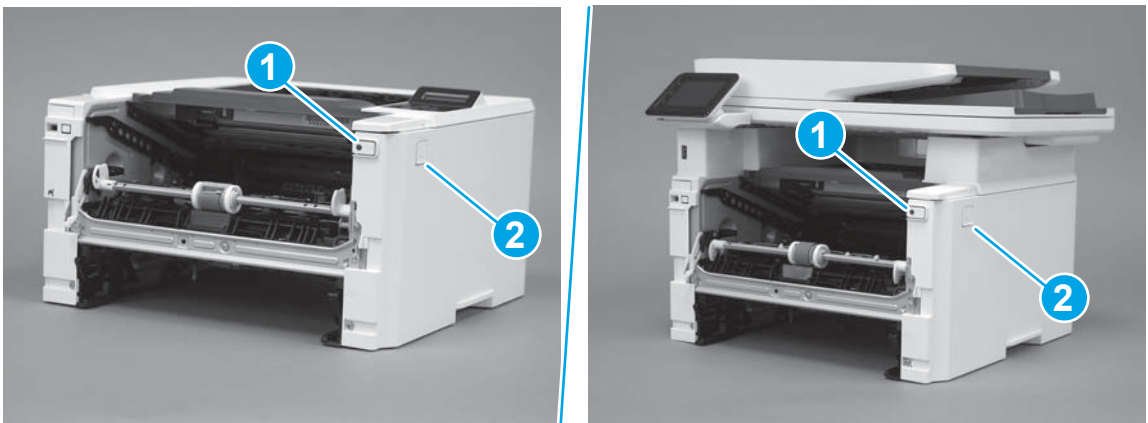

4. Install one screw (callout 1).

Figure 1-1333 Install one screw



Step 19: Install the left cover

1. At the front of the printer, do one of the following:
 - **M403/M402:** Position the cover on the printer (callout 1), and then engage two bosses (callout 2).
 - **M427/M426:** Position the cover on the printer (callout 3), engage one tab (callout 4), and then engage two bosses (callout 4).

Figure 1-1334 Install the cover

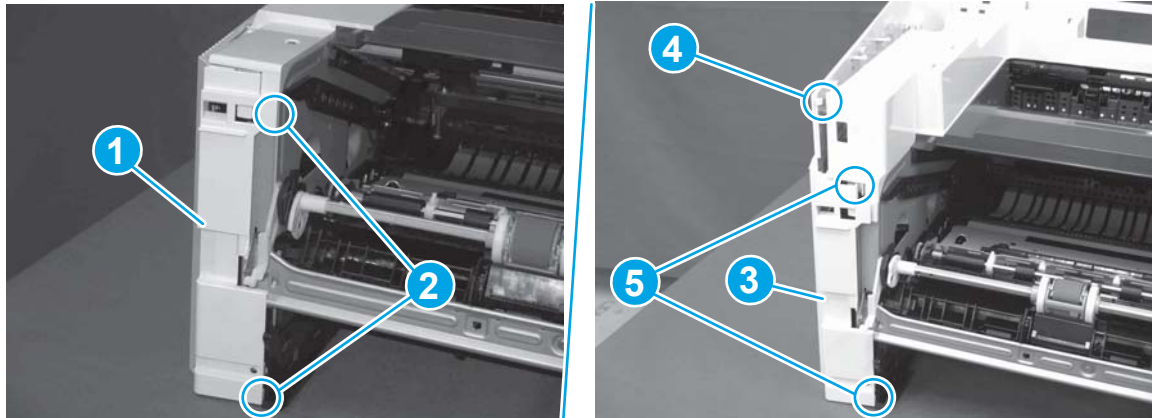

2. Carefully rotate the rear of the cover onto the printer (callout 1), engage three tabs (callout 2), and then engage two bosses (callout 3).

Figure 1-1335 Engage three tabs and two bosses

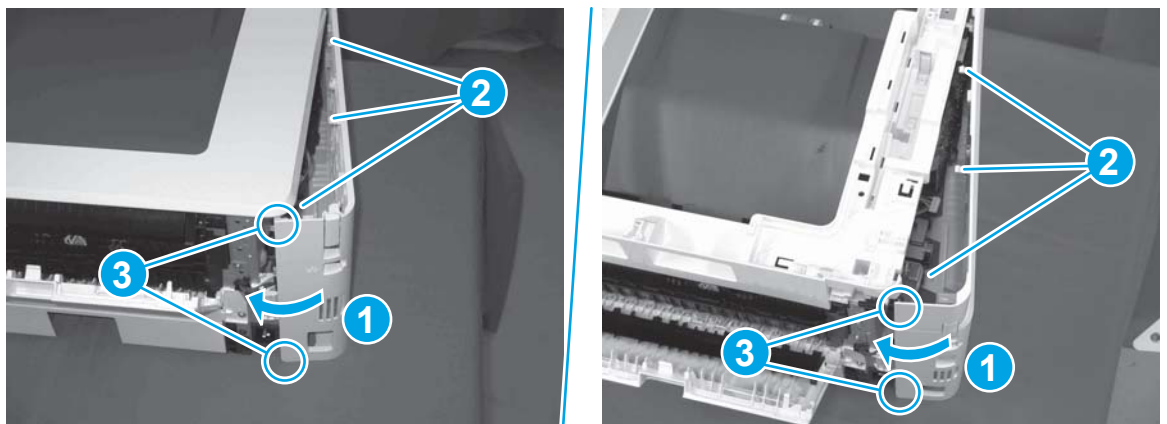

3. Install one screw (callout 1).

Figure 1-1336 Install one screw

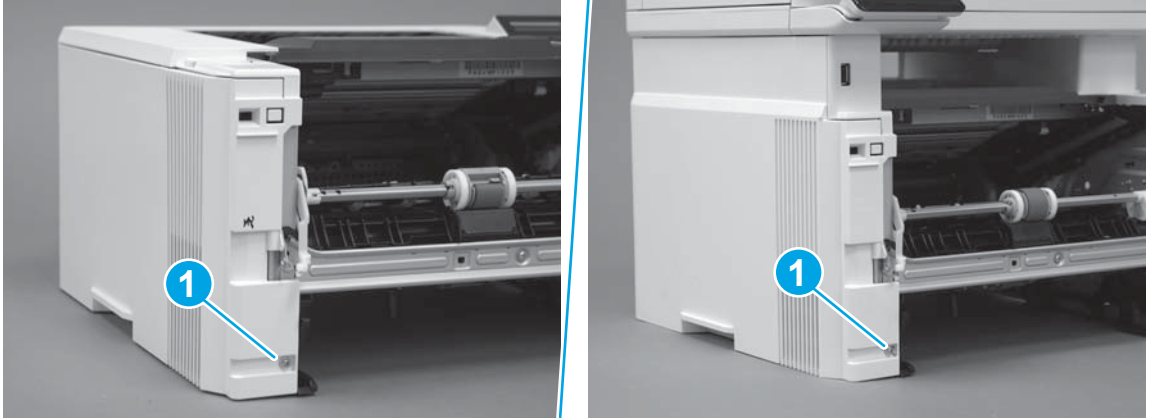

Step 20: Install the cartridge door assembly

 **Reinstallation tip:** After a replacement door is installed, make sure to install the nameplate (supplied in the kit) corresponding to the printer name on the door.

1. Position the door close to the printer, and then engage the keyed pin on the left-side retainer arm with the hole in the door.

Figure 1-1337 Engage the left-side retainer arm

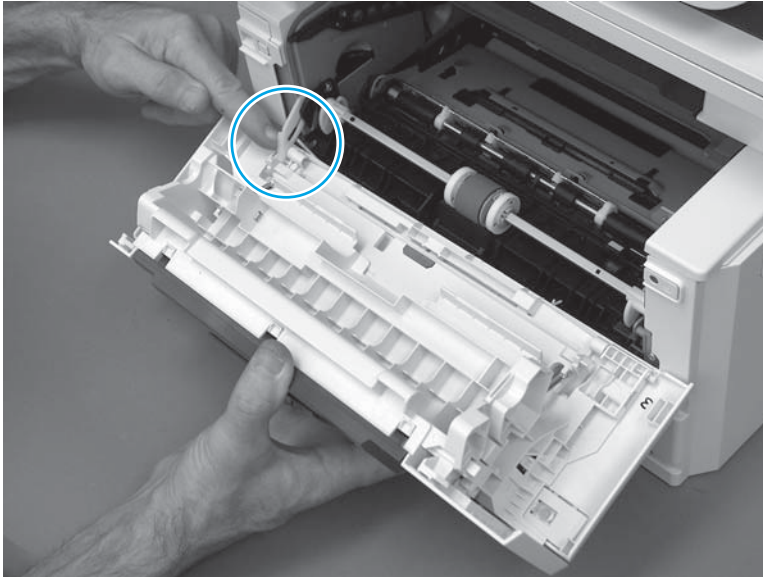

2. Engage the right-side door hinge pin with the hole in the chassis (callout 1).

Figure 1-1338 Install the door

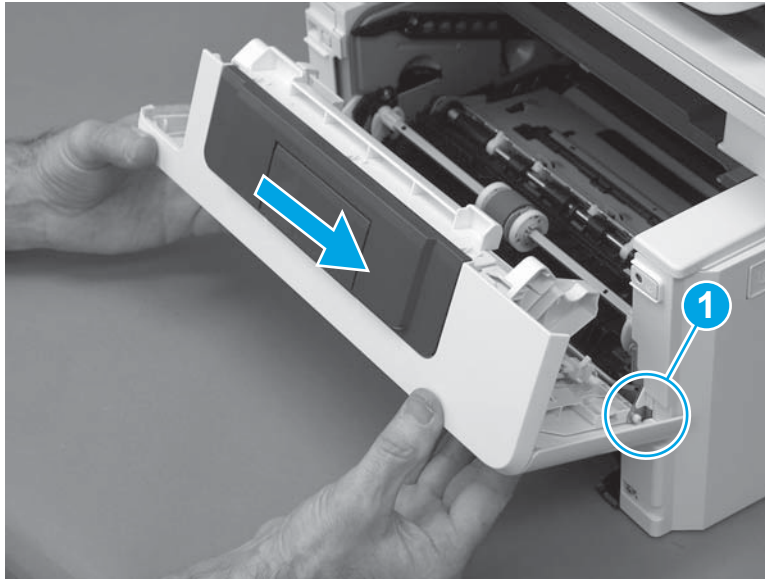

3. Install the link (callout 1).

 **IMPORTANT:** Make sure that the link snaps into place on the arm (callout 2). The link actuates the fuser pressure-release mechanism.

Figure 1-1339 Install the pressure-release link

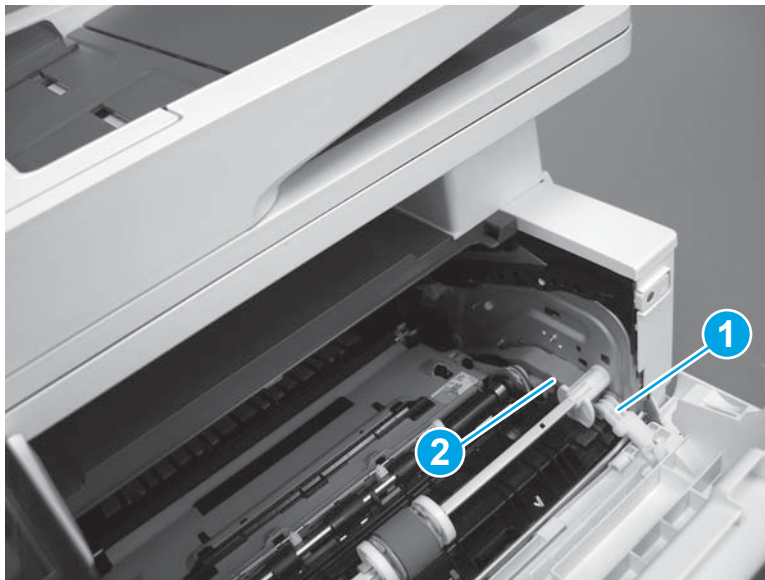

4. Slide the guide into the printer (callout 1), and then make sure that the tab (callout 2) snaps into place to secure the guide to the chassis.

Figure 1-1340 Install the guide

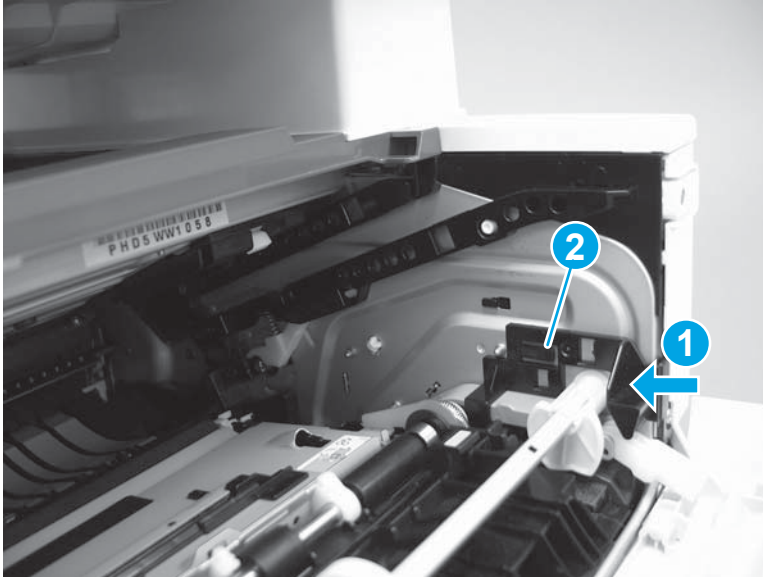

5. Position the shaft on the door, and then align the left-side hinge on the door with the hole in the chassis (callout 1).

Figure 1-1341 Align the hinge

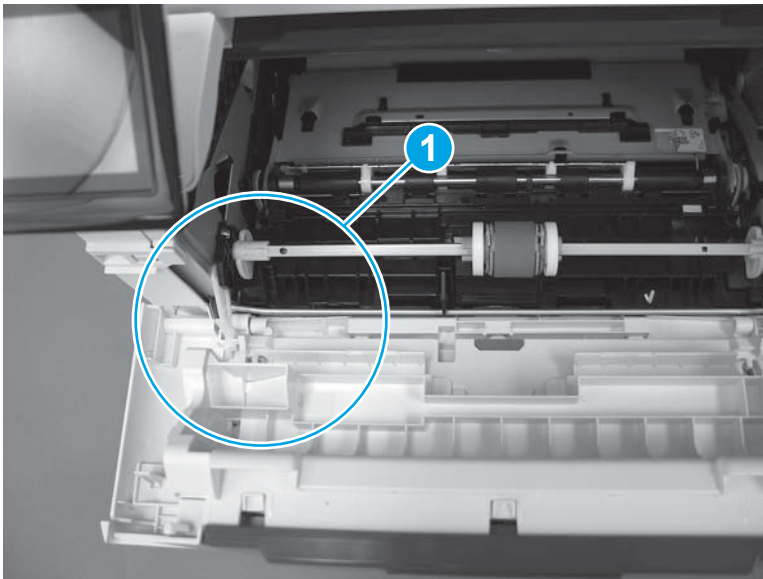

6. Push the shaft towards the left side of the printer to install it (callout 1).

 **Reinstallation tip:** Make sure that the support shaft is fully installed and correctly orientated (callout 2) so that it will not interfere with the door opening and closing.

Figure 1-1342 Install the support shaft



Step 21: Install Tray 2

- ▲ Slide the tray straight into the printer to install it.

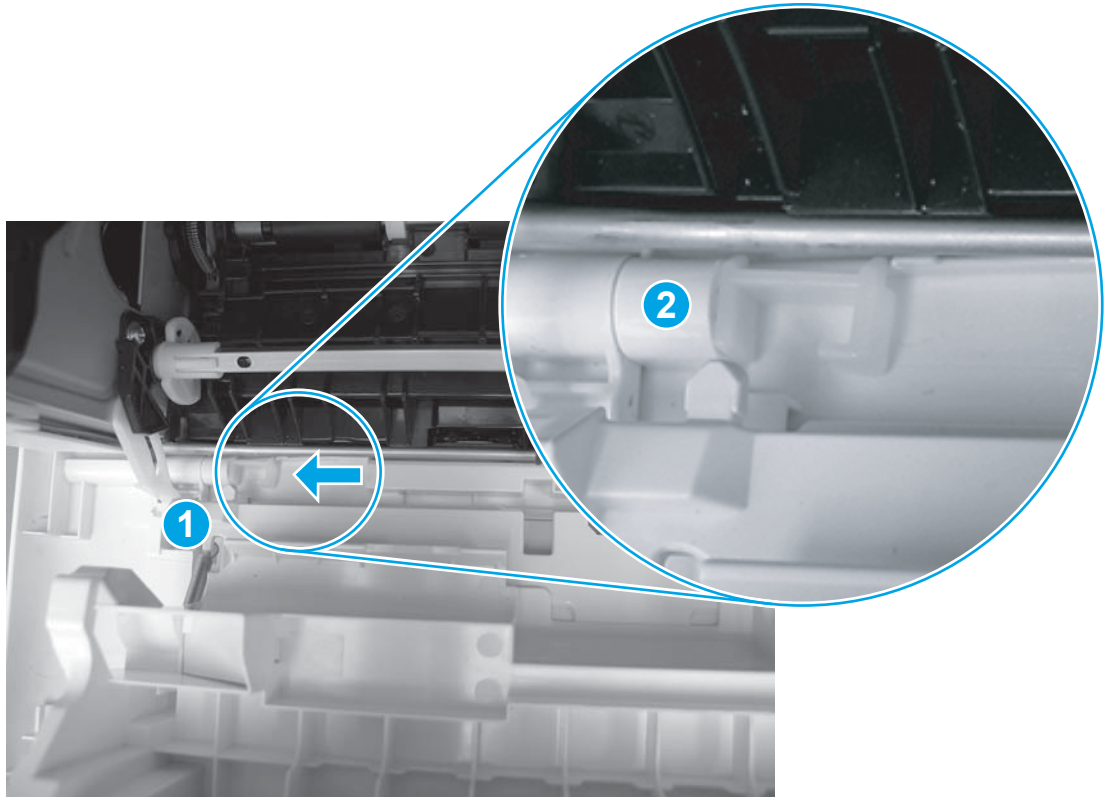
Figure 1-1343 Install the tray



Removal and replacement: DC controller

- [Introduction](#)
- [Step 1: Remove Tray 2](#)
- [Step 2: Remove the cartridge door assembly](#)
- [Step 3: Remove the left cover](#)
- [Step 4: Remove the right cover](#)
- [Step 5: Remove the rear door assembly](#)
- [Step 6: Remove the integrated scanner assembly \(M427/M246\)](#)
- [Step 7: Remove the control panel \(M427/M246\)](#)
- [Step 8: Remove the top cover \(M427/M426\)](#)
- [Step 9: Remove the top cover \(M403/M402\)](#)
- [Step 10: Remove the paper delivery tray \(output bin\)](#)
- [Step 11: Remove the sheet-metal formatter bracket and formatter](#)
- [Step 12: Remove the DC controller](#)
- [Step 13: Unpack the replacement assembly](#)
- [Step 14: Install the DC controller](#)
- [Step 15: Install the sheet-metal formatter bracket and formatter](#)
- [Step 16: Install the paper delivery tray \(output bin\)](#)
- [Step 17: Install the top cover \(M403/M402\)](#)
- [Step 18: Install the top cover \(M427/M426\)](#)
- [Step 19: Install the control panel \(M427/M246\)](#)
- [Step 20: Install the integrated scanner assembly \(M427/M246\)](#)
- [Step 21: Install the rear door assembly](#)
- [Step 22: Install the right cover](#)
- [Step 23: Install the left cover](#)
- [Step 24: Install the cartridge door assembly](#)
- [Step 25: Install Tray 2](#)

Introduction

This document provides the procedures to remove and replace the DC controller.

Before performing service

Turn the printer power off

- Disconnect the power cable.

 **WARNING!** To avoid damage to the printer, turn the printer off, wait 30 seconds, and then remove the power cable before attempting to service the printer.

Use the table below to identify the correct part number for your printer. To order the part, go to www.hp.com/buy/parts.

DC controller part number	
RM2-8680-000CN	DC controller

Required tools

- #2 Phillips screwdriver with a magnetic tip.

After performing service

Turn the printer power on

- Connect the power cable.
- Use the power switch to turn the power on.

Post service test

Make sure that the printer initializes to a **Ready** state.

Print a configuration page to make sure that the printer is functioning correctly.

Step 1: Remove Tray 2

- ▲ Pull the tray straight out of the printer to remove it.

Figure 1-1344 Remove the tray



Step 2: Remove the cartridge door assembly



NOTE: If the toner cartridge was not removed prior to servicing the printer, remove it now.

1. Release one tab (callout 1), and then slide shaft (callout 2) in the direction the arrow indicates and remove it.



TIP: It might be easier to release the support shaft by using a small flat-blade screwdriver.

Figure 1-1345 Release the support shaft

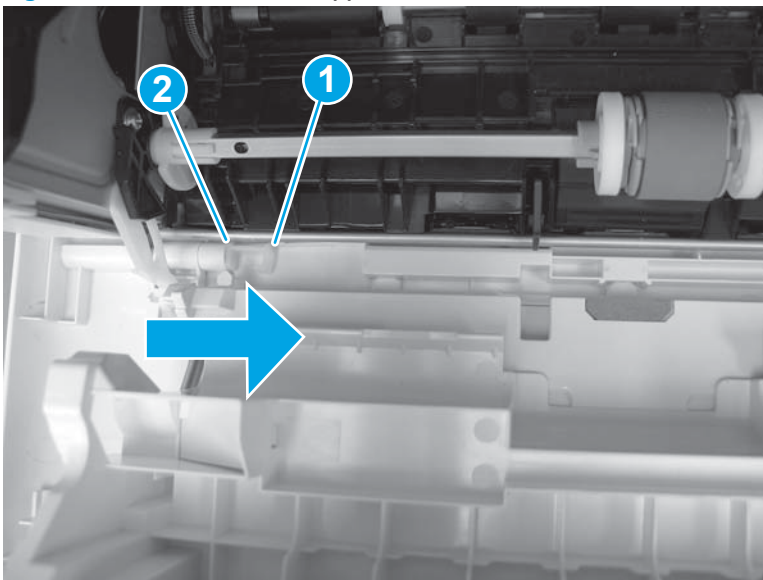

2. Release one tab (callout 1), and then slide the guide (callout 2) in the direction the arrow indicates and remove it.

Figure 1-1346 Remove the guide

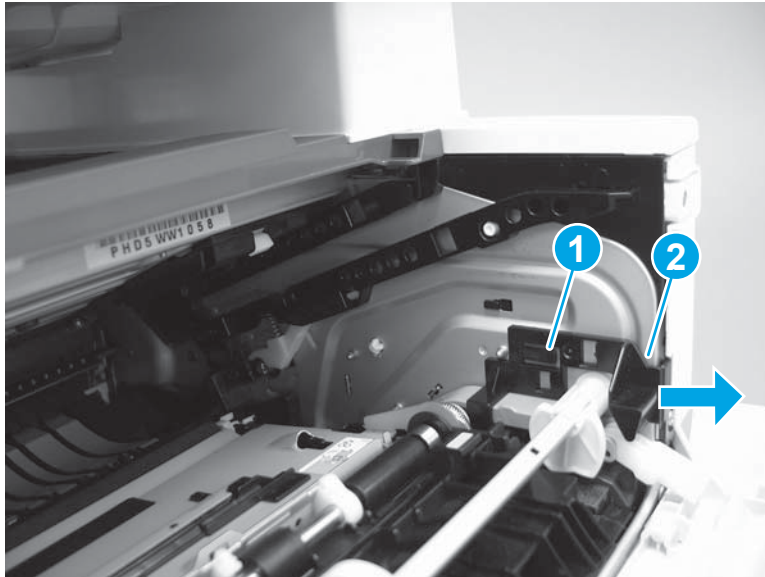

3. Remove the link arm (callout 1).

Figure 1-1347 Remove the link arm

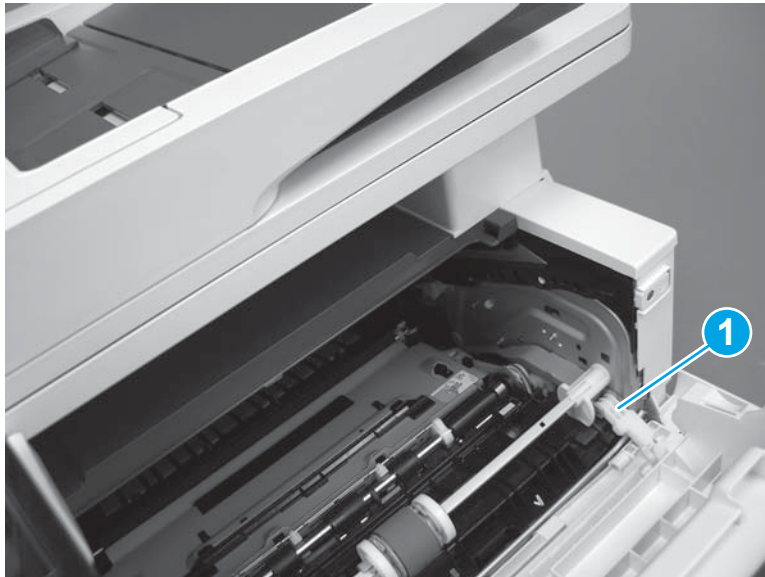

4. Slide the cartridge door assembly (callout 1) in the direction the arrow indicates and remove it.

Figure 1-1348 Remove the door

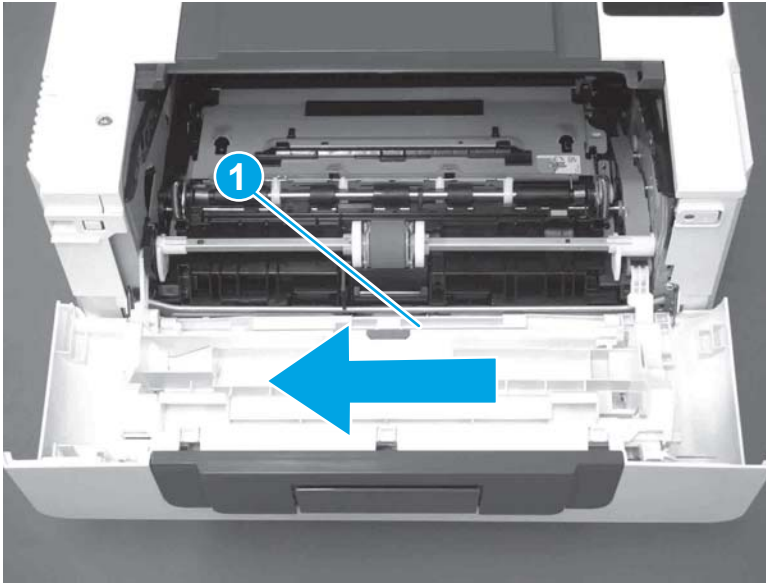

5. Remove the link (callout 1) from the cartridge door assembly (callout 2).

Figure 1-1349 Release the left-side retainer arm

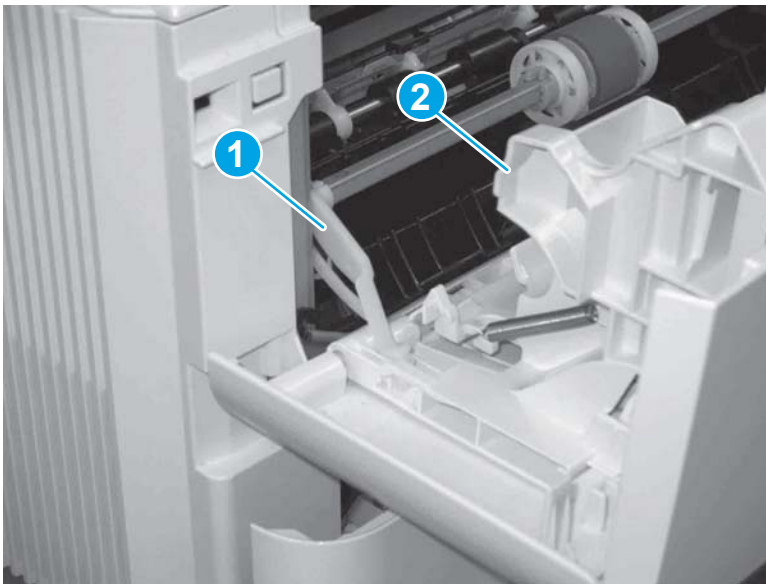

Step 3: Remove the left cover

1. Remove one screw (callout 1).

Figure 1-1350 Remove one screw

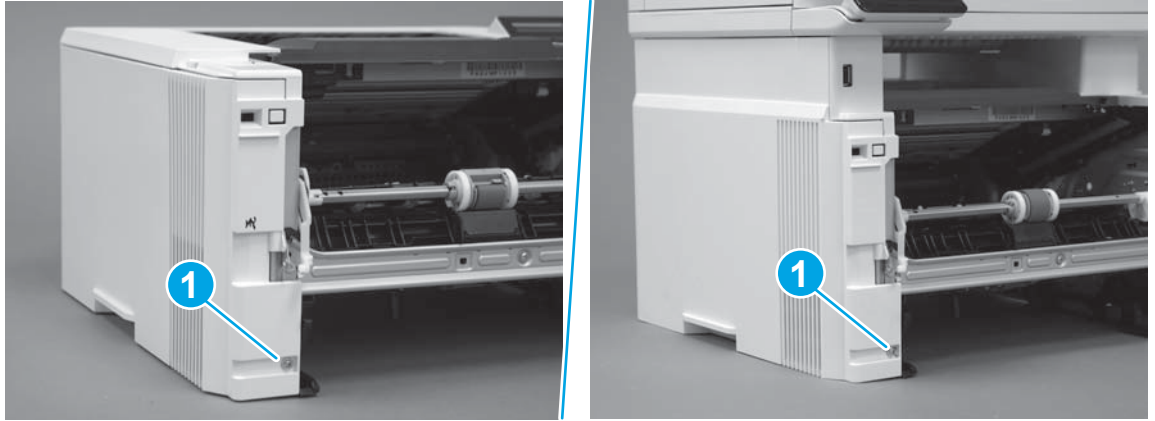

2. Open the rear door, release two bosses (callout 1), and then release three tabs (callout 2).

Figure 1-1351 Release two bosses and three tabs

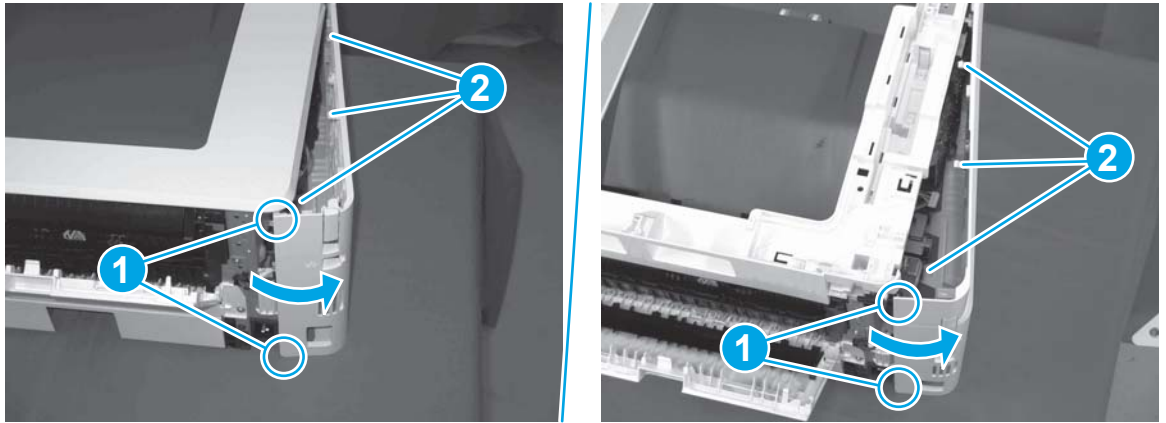

3. At the front of the printer, do one of the following:

- **M403/M402:** Release two bosses (callout 1), and then remove the cover (callout 2).
- **M427/M426:** Release one tab (callout 3), two bosses (callout 4), and then remove the cover (callout 5).

CAUTION: Be careful when releasing the upper bosses on the M427/M426 cover. One portion of the cover (callout 6) is fragile and is easily broken.

Figure 1-1352 Remove the cover

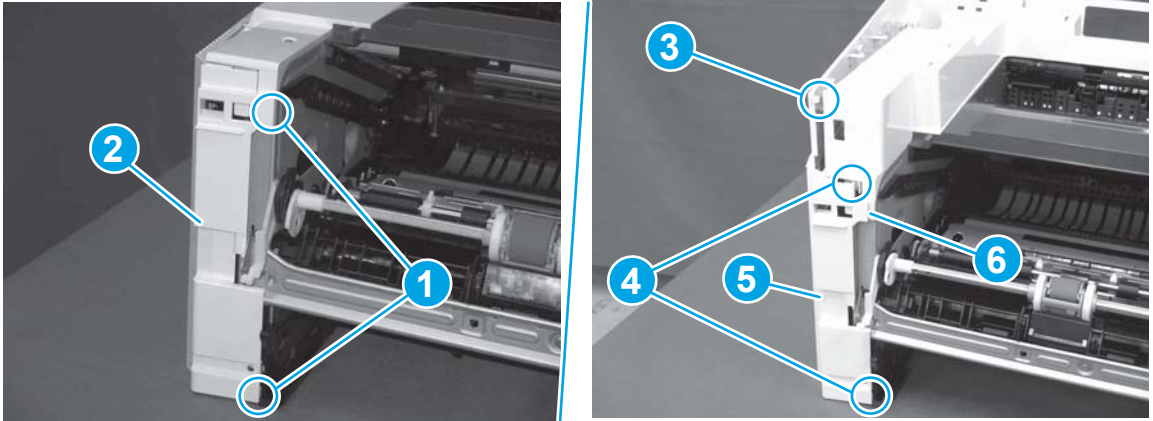

Step 4: Remove the right cover

1. Remove one screw (callout 1).

Figure 1-1353 Remove one screw



2. At the front of the printer, release two bosses (callout 1), and then release three tabs (callout 2).

Figure 1-1354 Release two bosses and three tabs

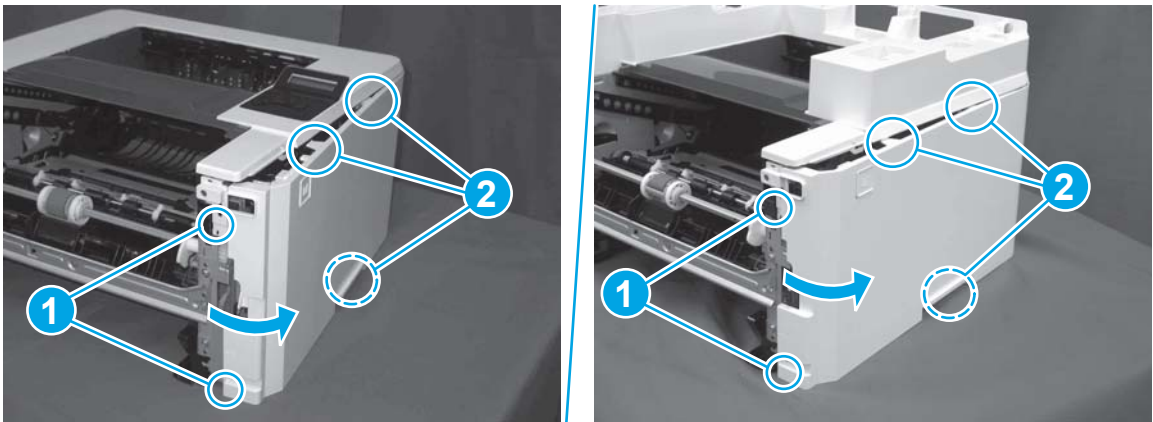

3. Open the rear door, release two bosses (callout 1), and then remove the cover (callout 2).

Figure 1-1355 Remove the cover

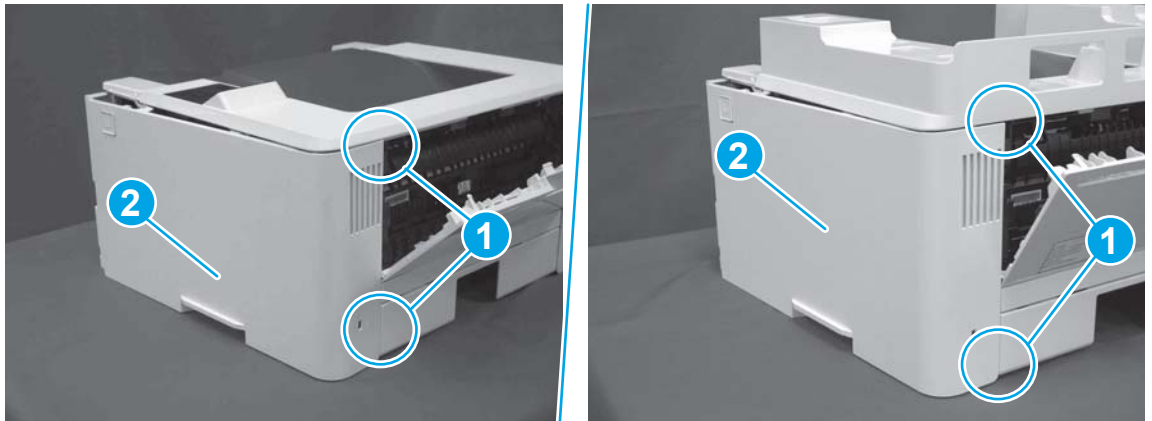

Step 5: Remove the rear door assembly

1. **Duplex models only:** Inside the Tray 2 cavity, press the green jam access lever (callout 1), and then lower the duplex feed assembly (callout 2).

Figure 1-1356 Duplex models, lower the duplex feed assembly

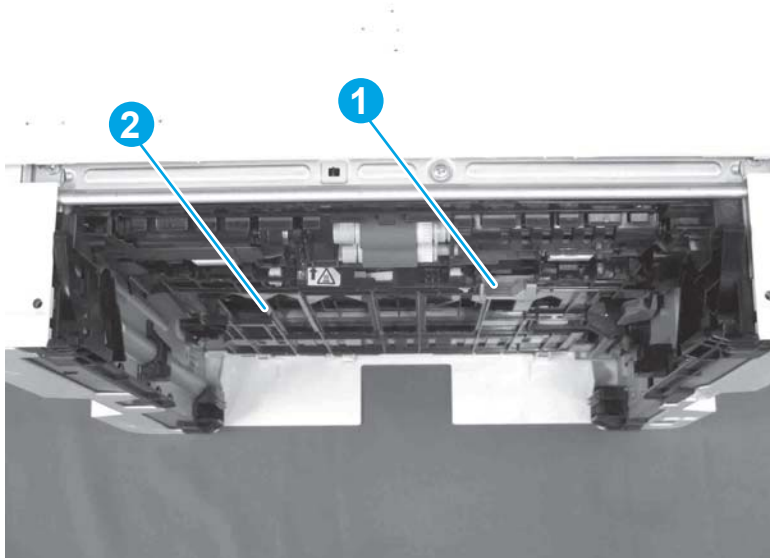

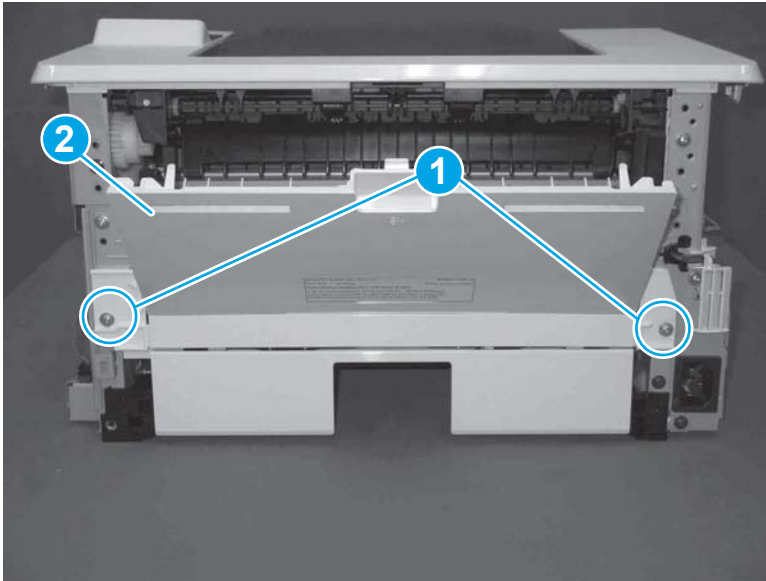

2. At the rear of the printer, remove two screws (callout 1), and then remove the rear door assembly (callout 2).

Figure 1-1357 Remove two screws



Step 6: Remove the integrated scanner assembly (M427/M246)

 **NOTE:** The step is for the M427/M426 printer. For the M403/M402, skip this step and go to [Step 9: Remove the top cover \(M403/M402\) on page 742](#).

 **NOTE:** M427/M426 models only. The integrated scanner assembly (ISA) includes the sub-scanner assembly (SSA) and the automatic document feeder (ADF).

1. Raise the ISA.

Figure 1-1358 Raise the ISA

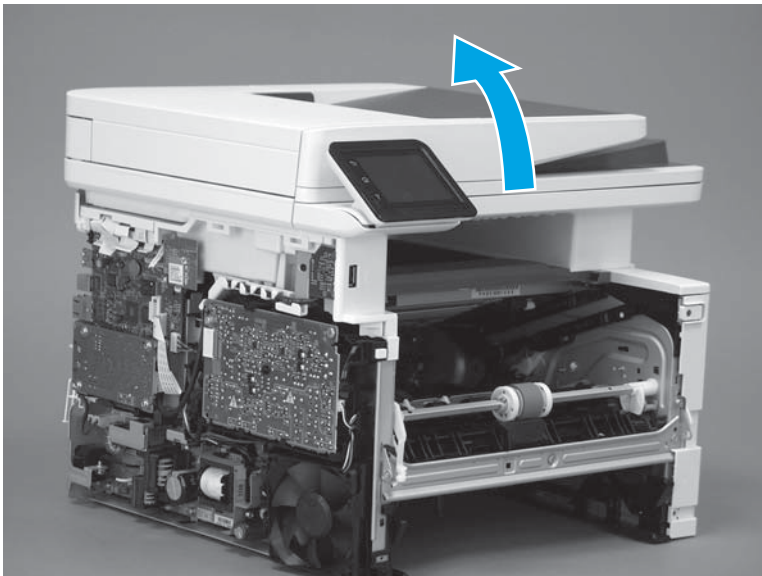

2. Release the ISA flat-flexible cable (FFC) cover (callout 1), and then remove it (callout 2).

Figure 1-1359 Remove the ISA FFC cover

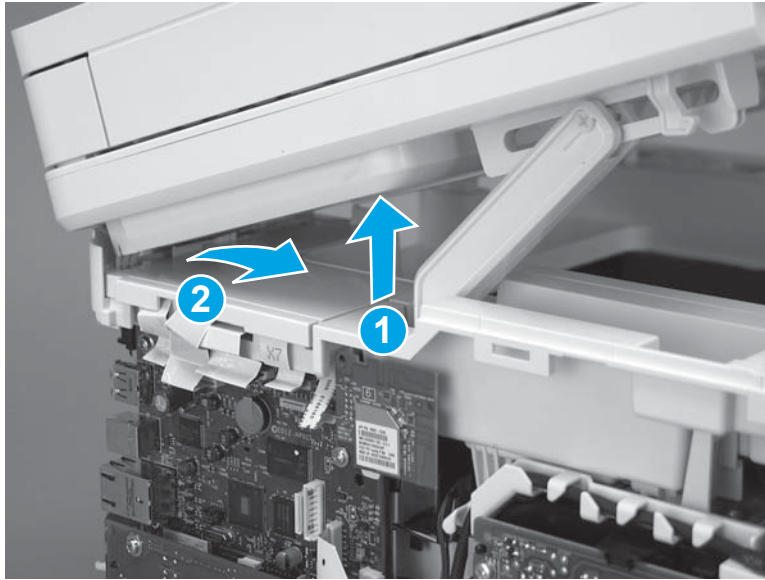

3. Disconnect three FFCs (callout 1), and then remove the ferrite (callout 2) from the holder.

CAUTION: The ferrite is not captive on the FFC. Do not lose the ferrite while handling the ISA.

Figure 1-1360 Disconnect three FFCs

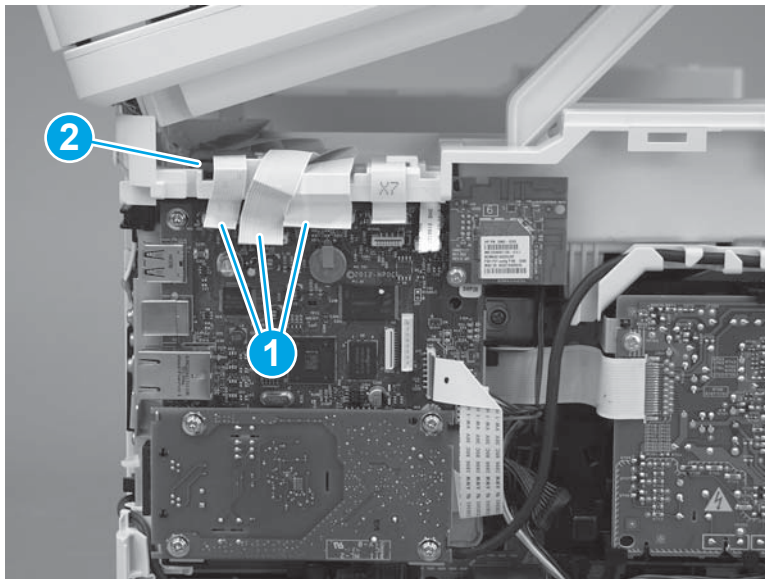

4. Remove one screw (callout 1).

Figure 1-1361 Remove one screw

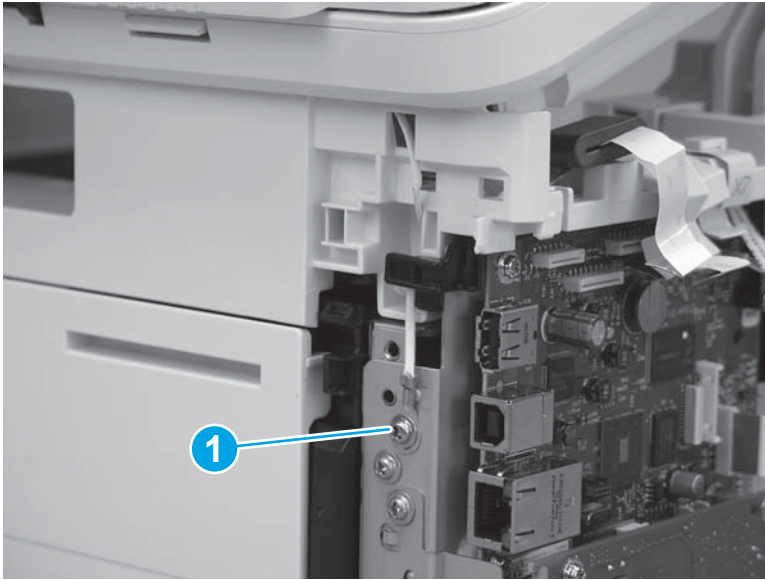

5. Pass the ground wire through the opening in the top cover.

Figure 1-1362 Pass the wire through the opening

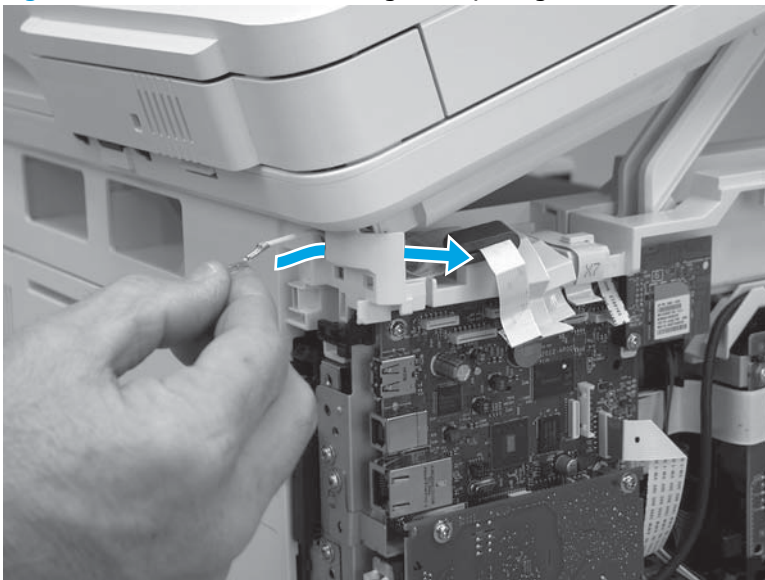

6. Release one tab (callout 1), and then rotate the ISA slider pin (callout 2) towards the front of the printer to release it.

Figure 1-1363 Release one tab and rotate the slider pin

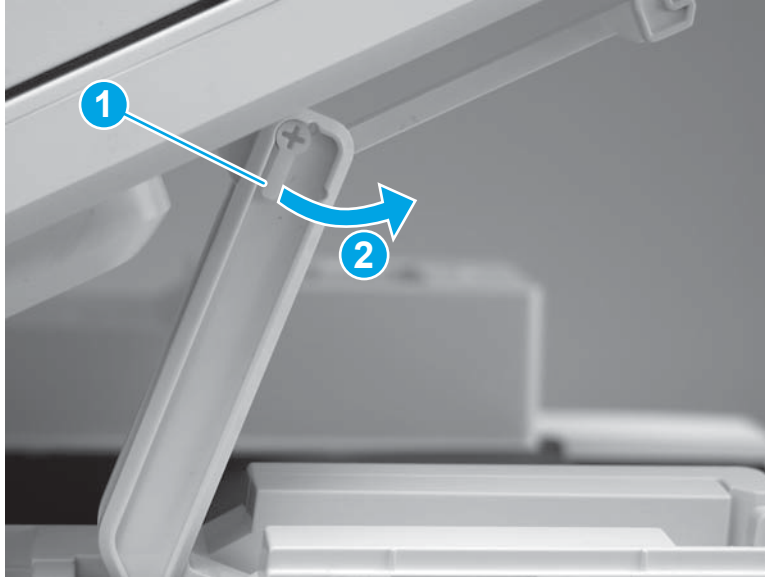

7. Remove the slider pin.

Figure 1-1364 Remove the slider pin

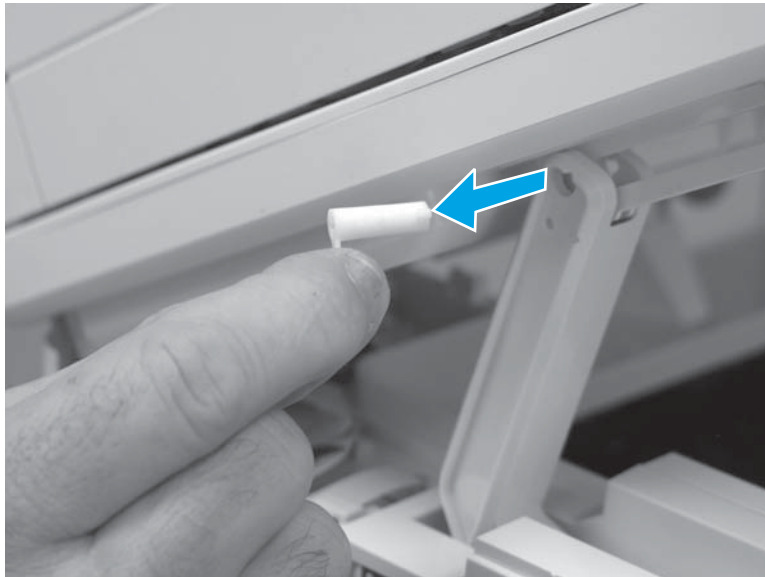

8. Rotate the ISA towards the rear of the printer until it stops.

Figure 1-1365 Rotate the ISA towards the rear of the printer



9. Slide the ISA as shown to release it.

Figure 1-1366 Release the ISA

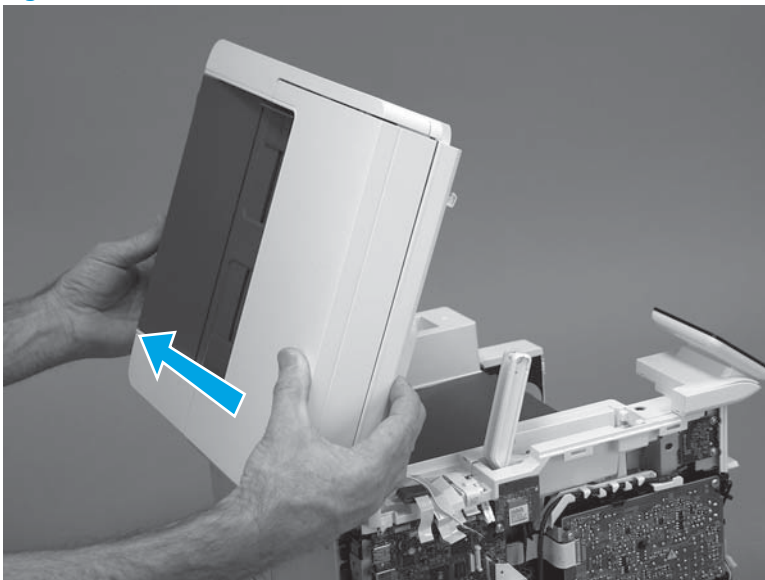

10. Remove the ISA.

Figure 1-1367 Remove the ISA

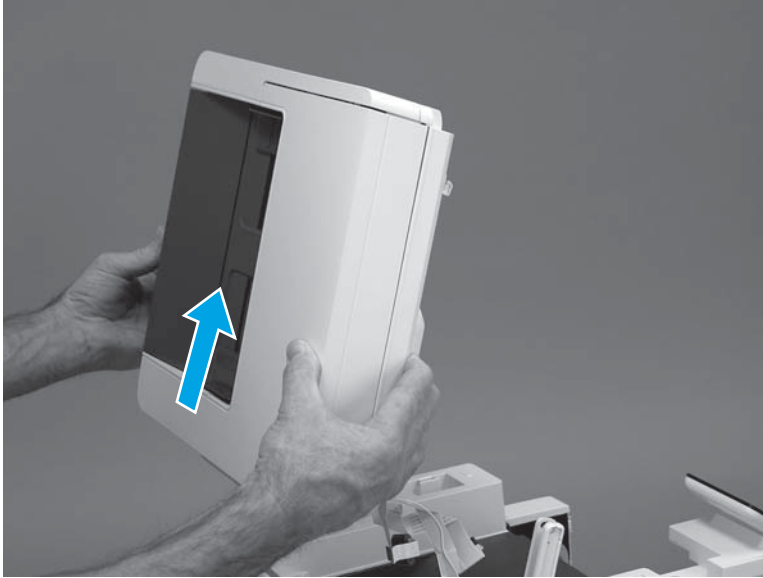

Step 7: Remove the control panel (M427/M246)

 **NOTE:** The step is for the M427/M426 printer. For the M403/M402, skip this step and go to [Step 9: Remove the top cover \(M403/M402\) on page 742](#).

1. Disconnect one FFC (callout 1; J114), and then release the FFC from the retainer (callout 2).

Figure 1-1368 Disconnect one connector

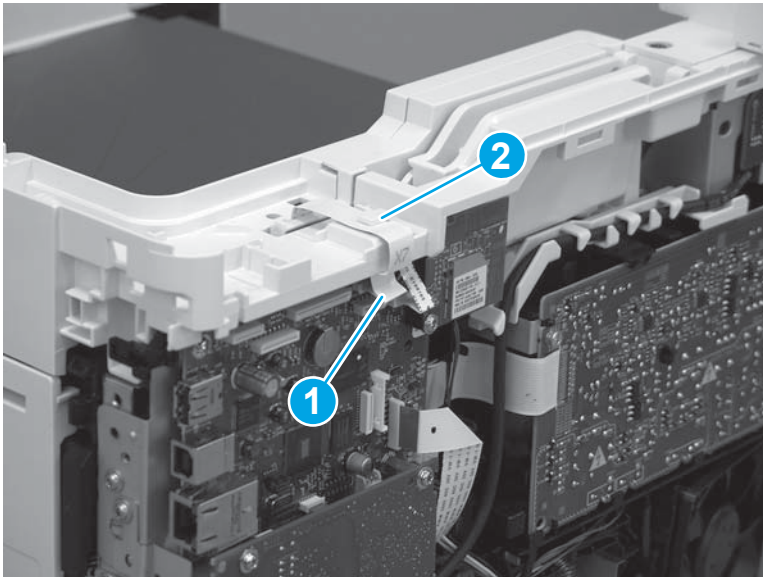

2. Remove one screw (callout 1).

Figure 1-1369 Remove one screw

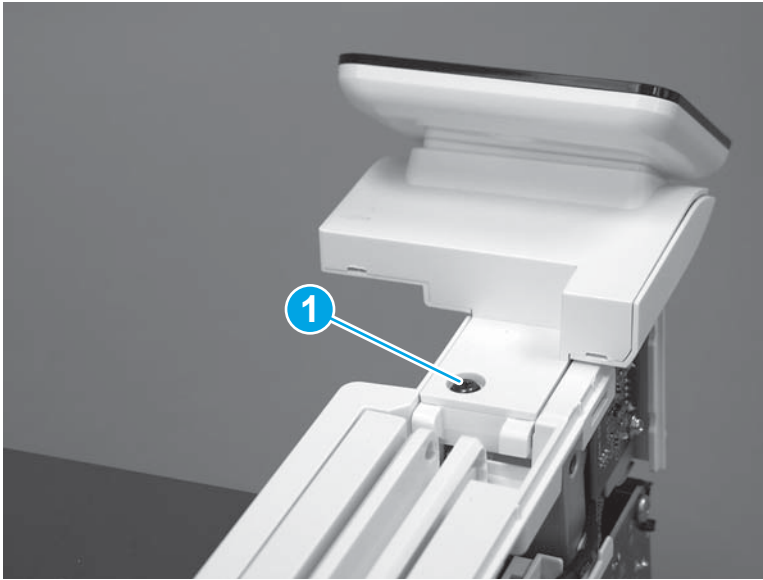

3. Use a small flat-blade screwdriver to release two tabs (callout 1) on the control-panel cable cover.

Figure 1-1370 Release two tabs

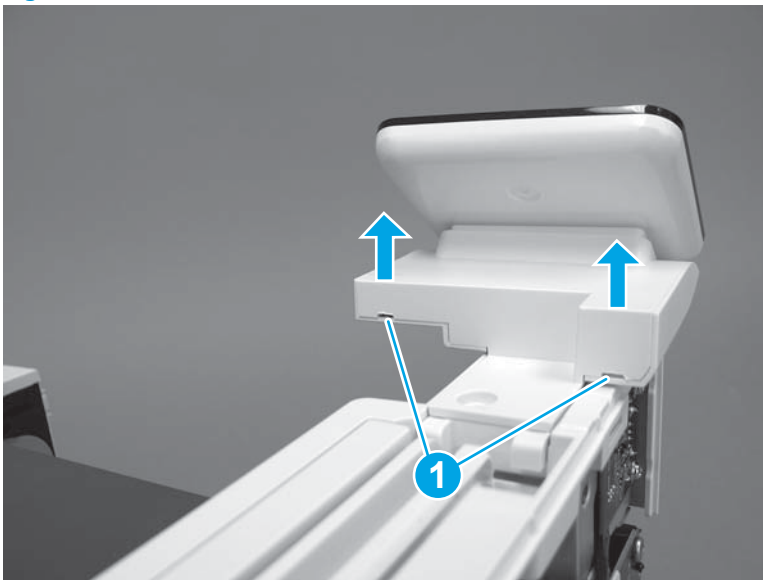

4. Remove the control-panel cable cover.

Figure 1-1371 Remove the cover

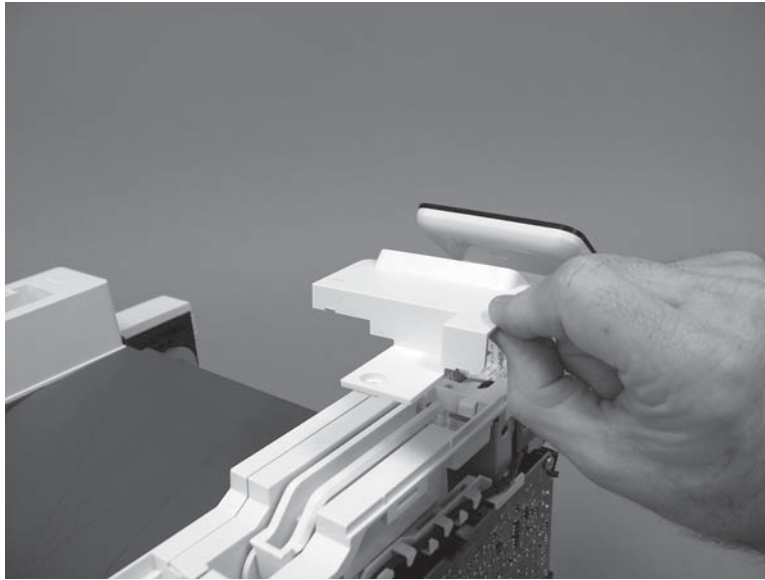

5. Remove one grounding screw (callout 1), and then move the ground cable (callout 2) out of the way.

Figure 1-1372 Remove one screw

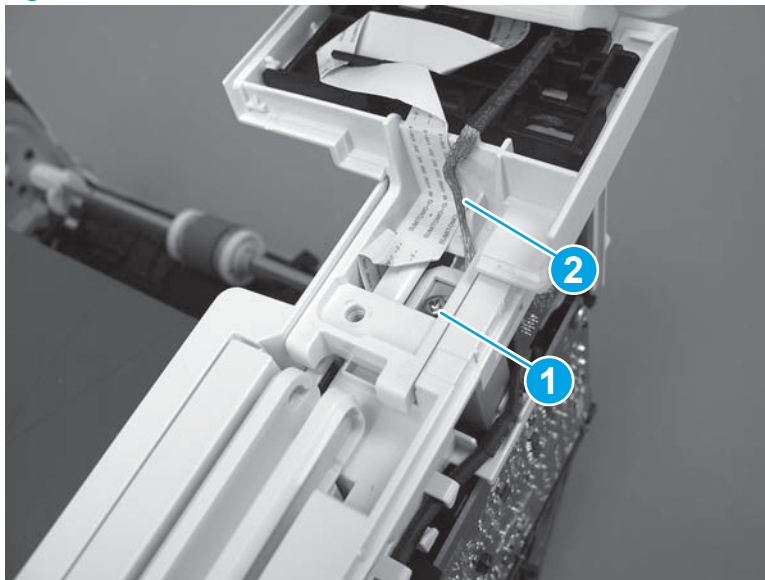

6. Move the FFC out of the way, and then remove two screws (callout 1).

Figure 1-1373 Remove two screws

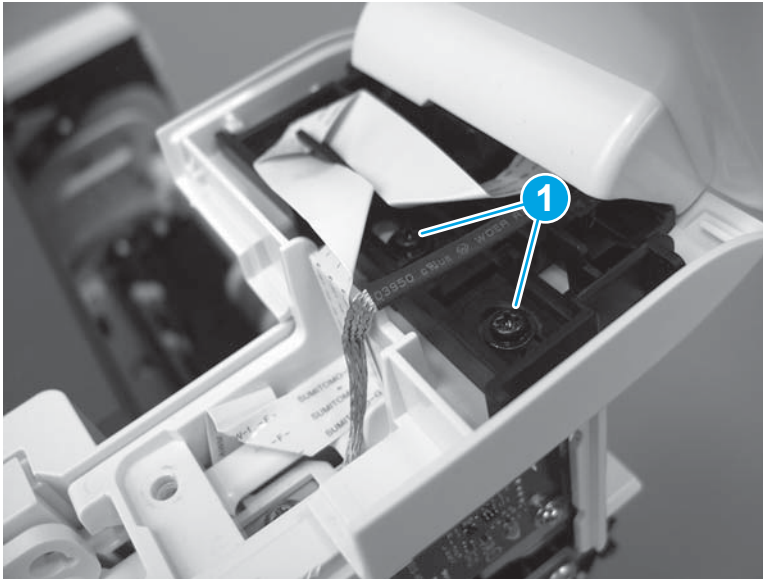

7. Slightly lift up the control-panel assembly to separate it from the top cover.

CAUTION: The control panel assembly is still connected to the printer by the FFC. Do not attempt to completely remove the assembly.

Figure 1-1374 Lift up the control-panel assembly

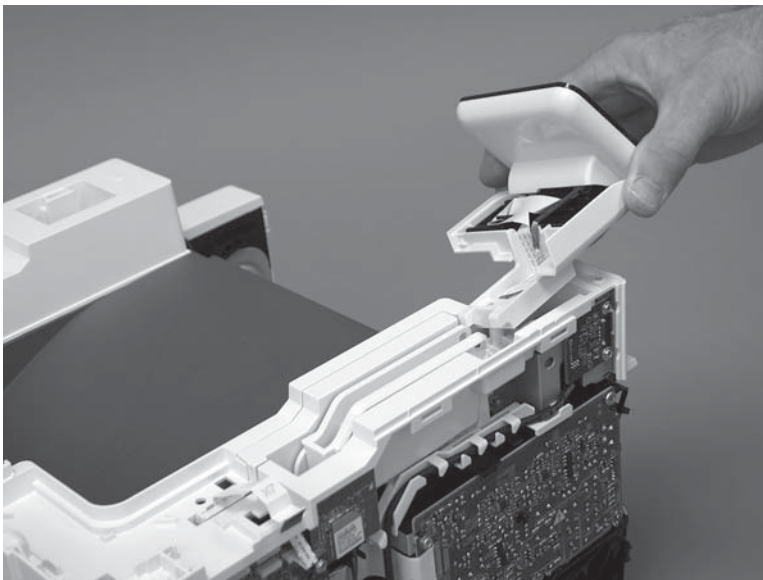

8. Lift up the control-panel FFC cover to remove the control-panel assembly.

Figure 1-1375 Remove the control-panel assembly

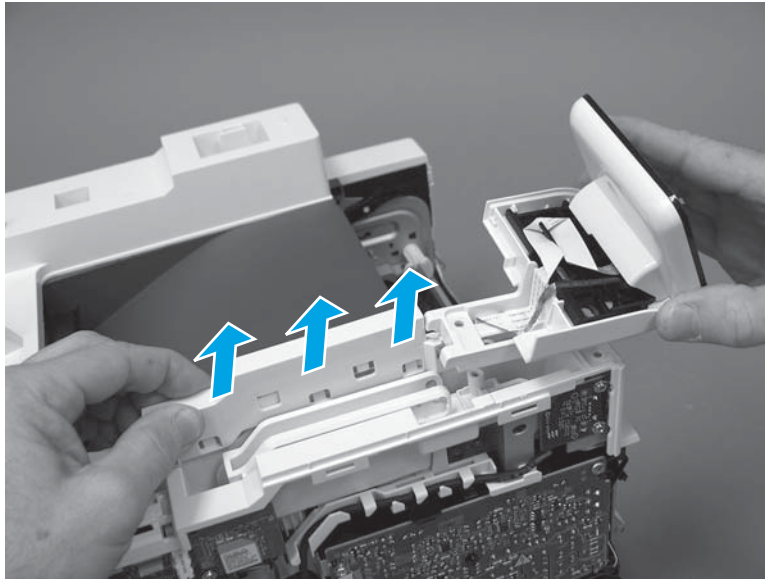

Step 8: Remove the top cover (M427/M426)

 **NOTE:** The step is for the M427/M426 printer. For the M403/M402, skip this step and go to [Step 9: Remove the top cover \(M403/M402\) on page 742](#).

1. Release the USB cable (callout 1) from the cable guide.

Figure 1-1376 Remove the USB cable

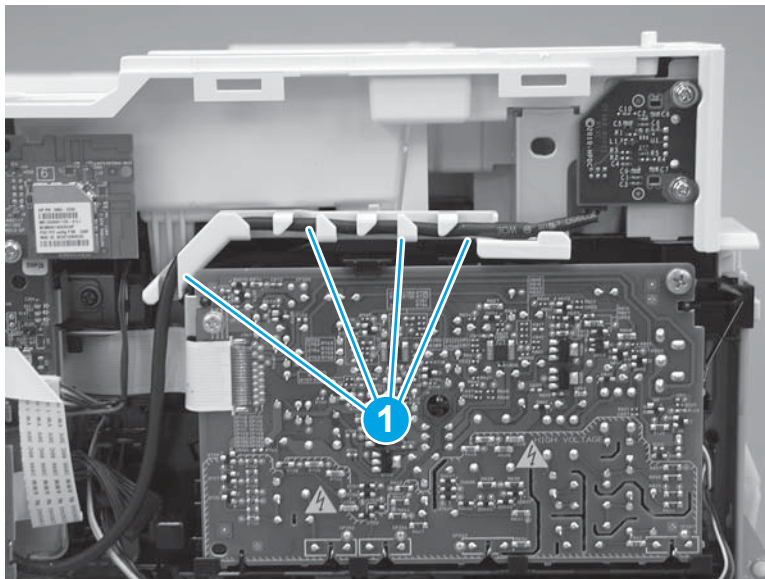

2. Remove five screws (callout 1), release four bosses (callout 2), and then remove the top cover (callout 3).

Figure 1-1377 Remove the cover

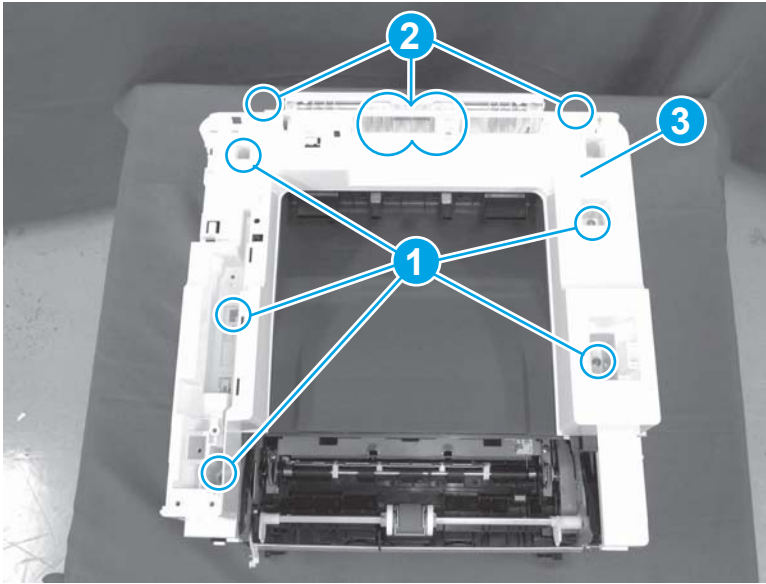

Step 9: Remove the top cover (M403/M402)

 **NOTE:** The step is for the M403/M402 printer. For the M427/M426, skip this step and go to [Step 10: Remove the paper delivery tray \(output bin\) on page 743.](#)

1. Remove one screw (callout 1).

Figure 1-1378 Remove one screw



2. At the right side of the printer, release the one boss (callout 1), and then release one tab (callout 2).

Figure 1-1379 Release one boss and one tab

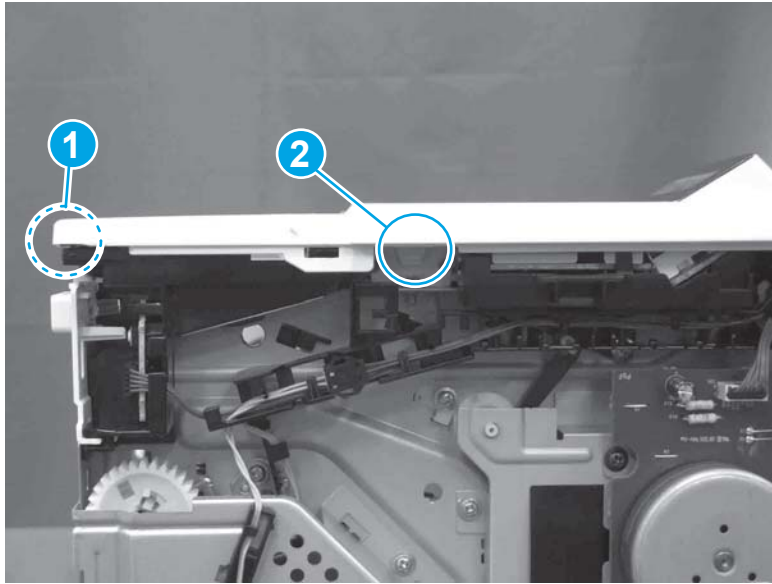

3. Release four tabs (callout 1), release four bosses (callout 2), and then remove the top cover (callout 3).



 **TIP:** Open the rear door to make releasing the bosses (callout 3) easier.

Figure 1-1380 Remove the cover

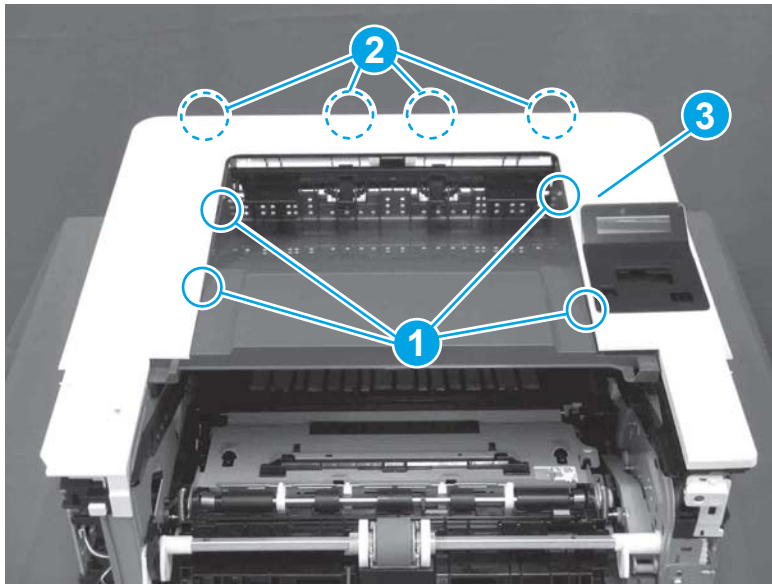

Step 10: Remove the paper delivery tray (output bin)

 **NOTE:** This procedure shows the M403/M402 model, however, the paper delivery tray (output bin) removal is similar for the M427/M426 printer.

- ▲ Release two bosses (callout 1), release two tabs (callout 2), and then remove the paper delivery tray (output bin; callout 3).

Figure 1-1381 Release two tabs

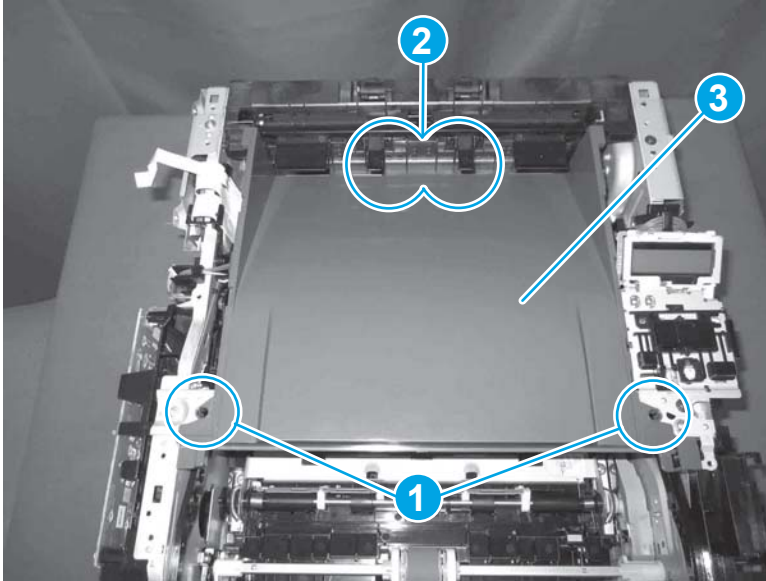

Step 11: Remove the sheet-metal formatter bracket and formatter

 **NOTE:** Disconnect any remaining formatter PCA FFCs or wire-harness connectors.

1. **M427/M426 only:** Remove the guide (callout 1).

Figure 1-1382 Remove the guide

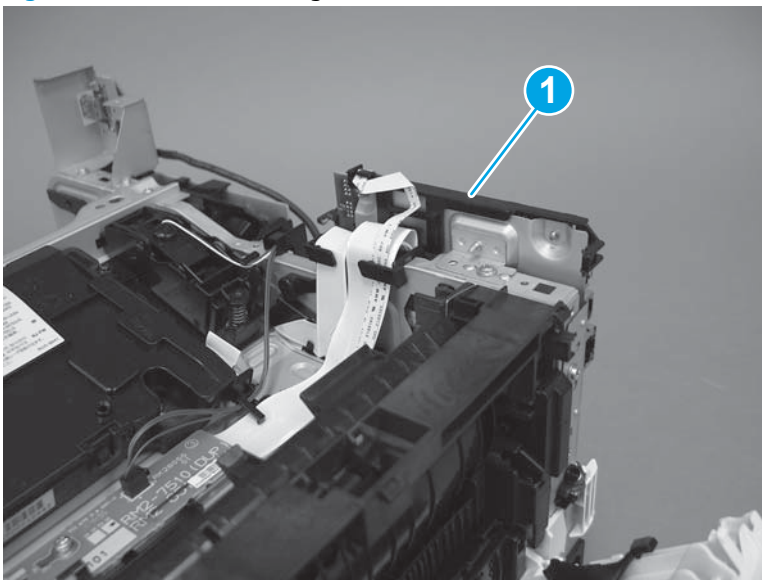

2. Remove two screws (callout 1).

Figure 1-1383 Remove two screws

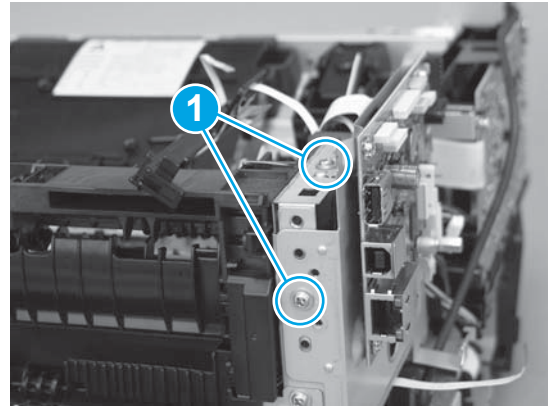
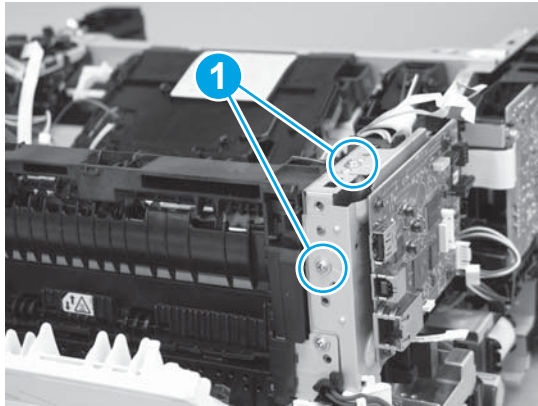

3. Disconnect one connector (callout 1), and then release the wire harness from the guide (callout 2).

Figure 1-1384 Disconnect one connector

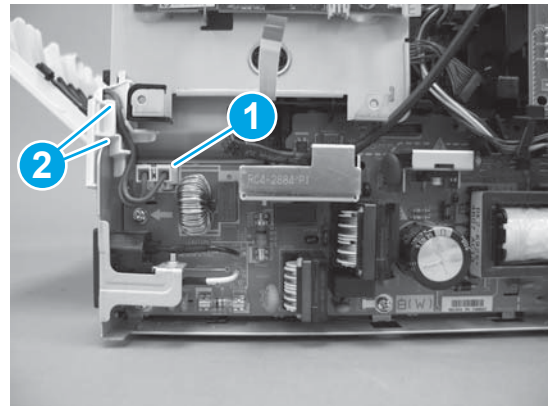
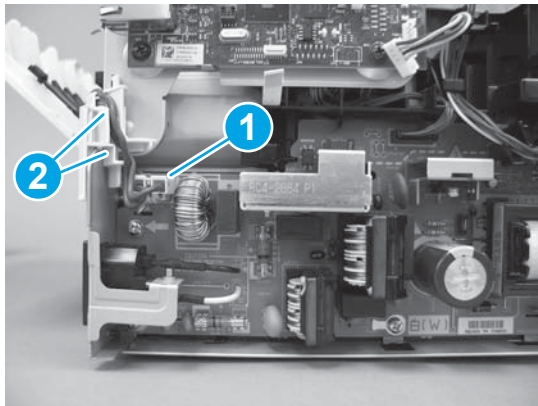

4. Remove the guide (callout 1).

Figure 1-1385 Remove the guide

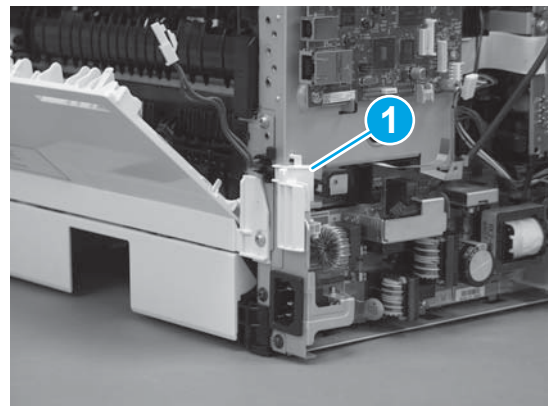
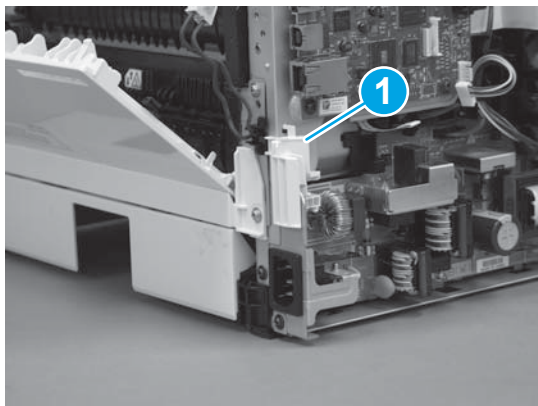

5. Remove three screws (callout 1).

Figure 1-1386 Remove three screws

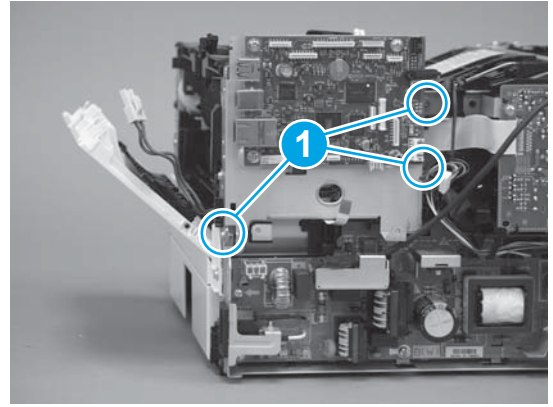
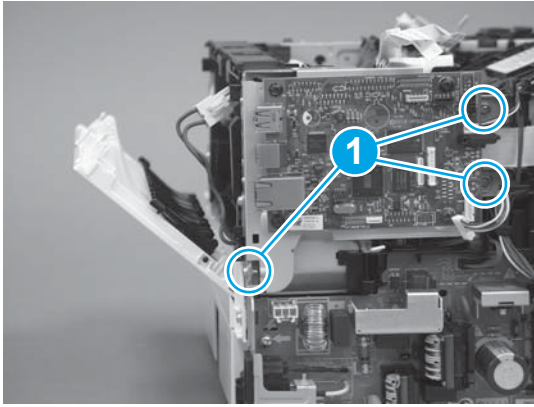

6. Remove the sheet-metal bracket and formatter PCA.

Figure 1-1387 Remove the bracket

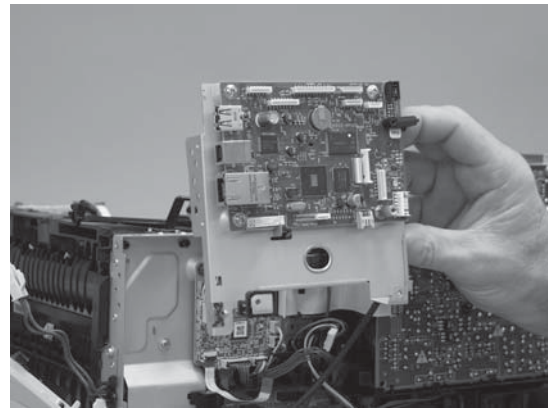
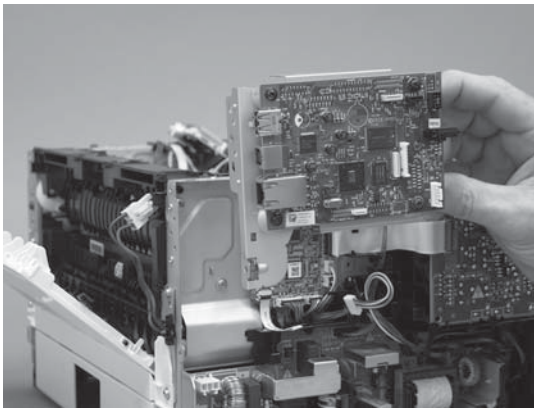

Step 12: Remove the DC controller

1. Disconnect three FFCs (callout 1), and six connectors (callout 2).

 **IMPORTANT:** One FFC (callout 3) is fastened to the guide with two sided tape. This FFC will be removed later in the procedure.

Figure 1-1388 Disconnect three FFCs and six connectors



2. Remove two screws (callout 1).

Figure 1-1389 Remove two screws

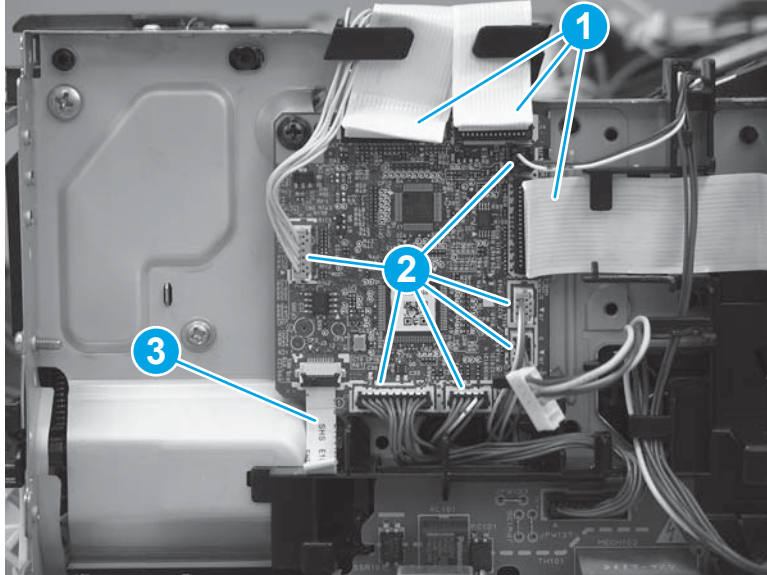
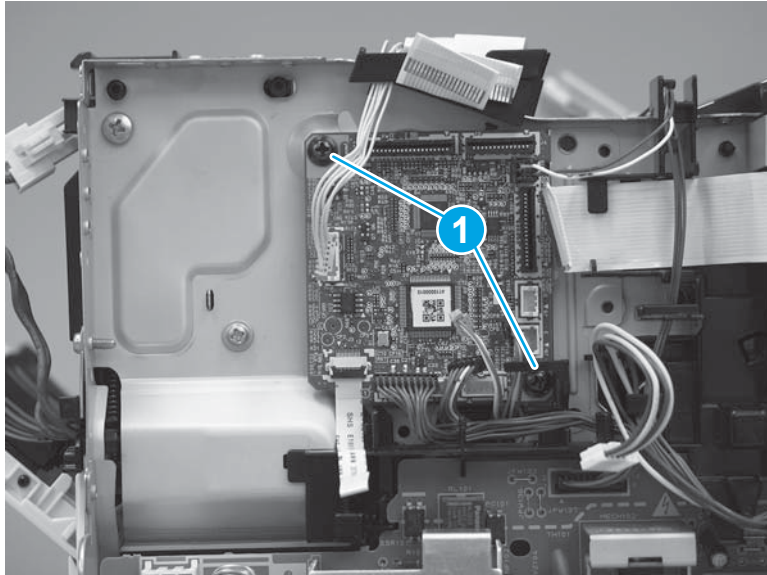

3. Separate the DC controller from the printer.

CAUTION: Carefully pull up on the FFC (callout 1) to release it from the guide, and then remove the DC controller.

Figure 1-1390 Remove the DC controller

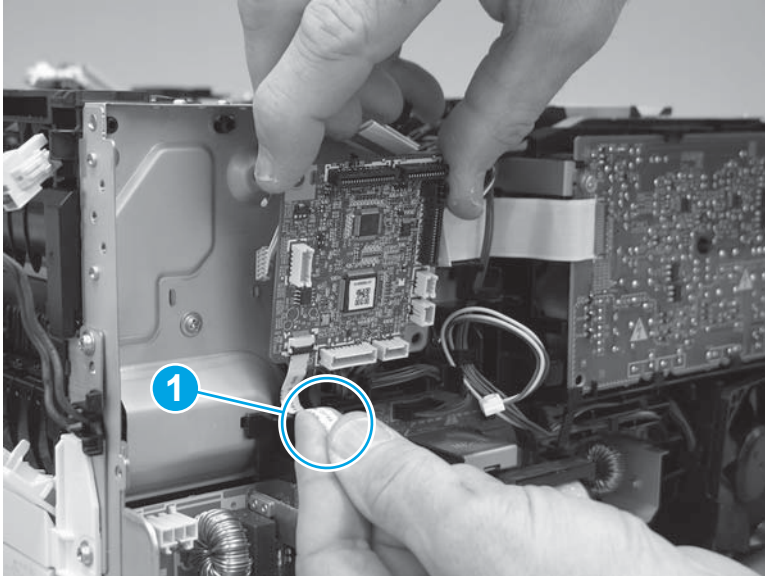

4. Disconnect one the FFC.

IMPORTANT: The FFC connector is a Zero Insertion Force (ZIF) connector that uses a hinged retainer to secure the FFC. The hinged retainer must be opened to release the FFC.

Do not discard this FFC. It must be installed on the replacement DC controller

Figure 1-1391 Disconnect one the FFC

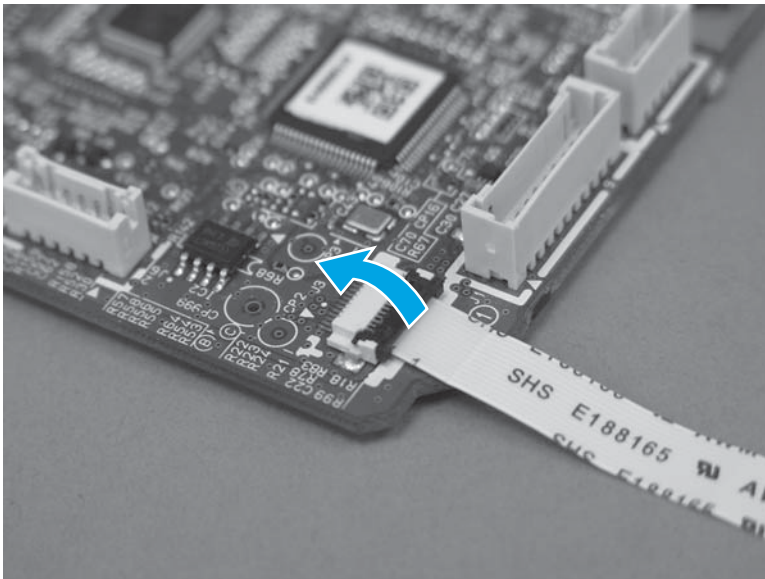

Step 13: Unpack the replacement assembly

Unpack the replacement part from the packaging.

 **NOTE:** HP recommends responsible disposal of the defective part.

Figure 1-1392 Recycle and unpack

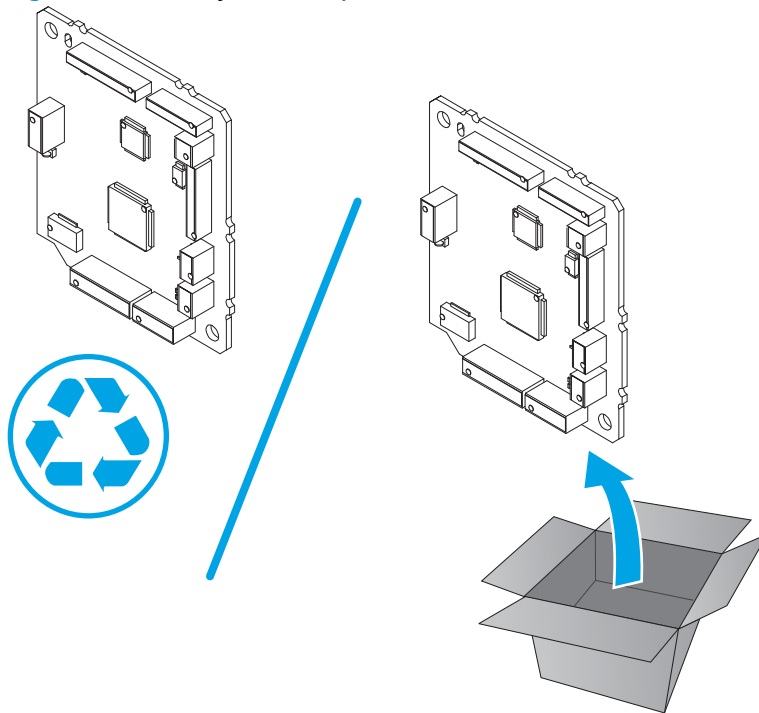

Step 14: Install the DC controller

1. Connect the formatter FFC to the replacement DC controller connector.

Make sure that the FFC is fully inserted into the connector body, close the hinged retainer to lock the cable in place, and then slightly tug on the cable to make sure it is securely fastened.

 **IMPORTANT:** The ZIF connector hinged retainer must be in the open position to insert the FFC.

Figure 1-1393 Connect one the FFC



2. Position the DC controller on the printer, and then install two screws (callout 1).

Figure 1-1394 Install the DC controller

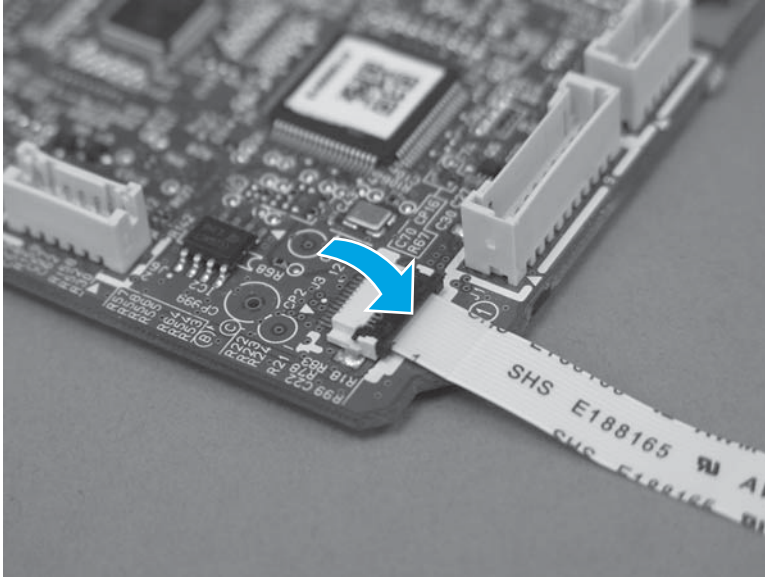
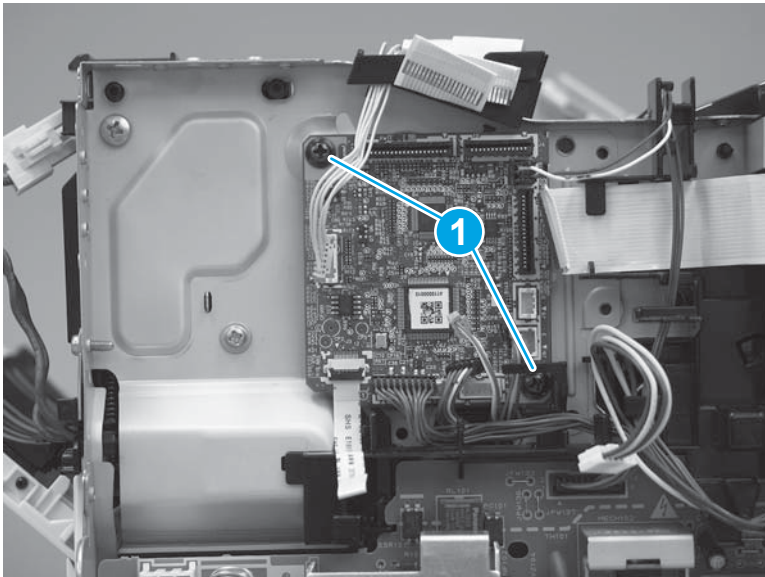

3. Connect three FFCs (callout 1), and six connectors (callout 2).

Figure 1-1395 Connect three FFCs and six connectors

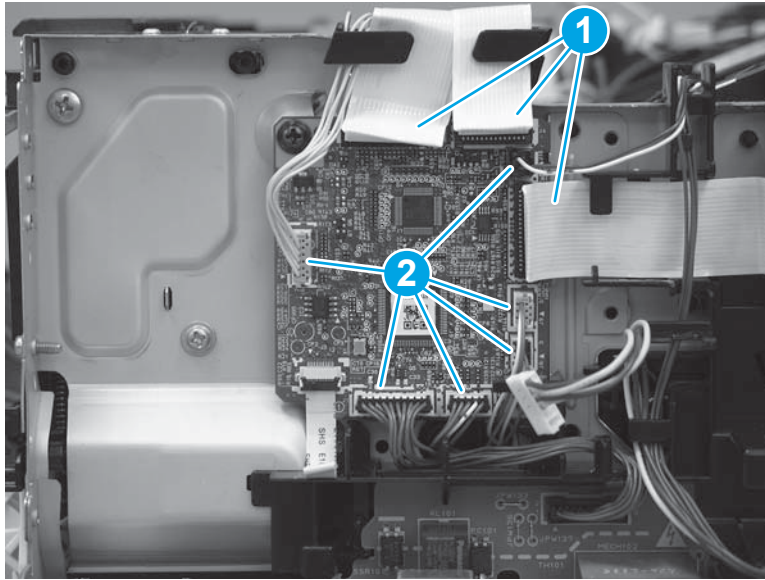

4. Carefully push on the FFC (callout 1) to adhere it to the guide.

 **Reinstallation tip:** The two sided tape on the back side of FFC might need to be replaced if it will not adhere to the guide.

Figure 1-1396 Adhere the FFC to the guide



Step 15: Install the sheet-metal formatter bracket and formatter

 **NOTE:** Disconnect any remaining formatter PCA FFCs or wire-harness connectors.

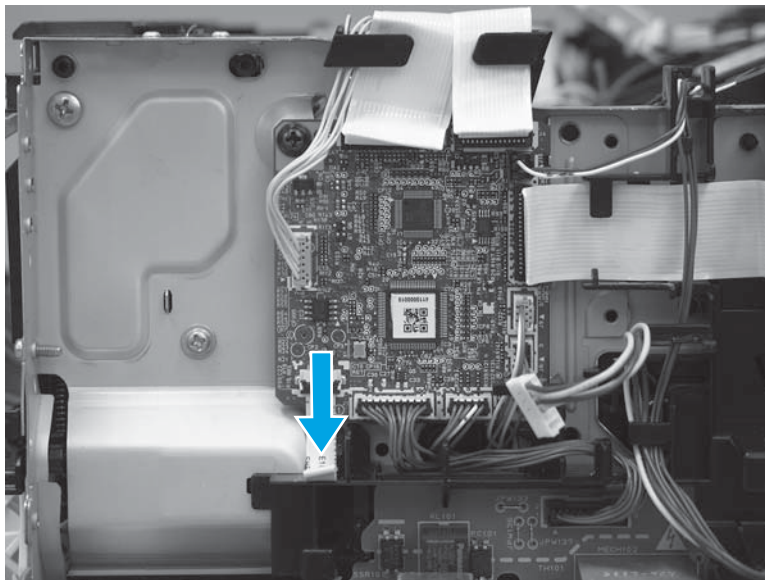
1. **M427/M426 only:** Remove the guide (callout 1).

Figure 1-1397 Remove the guide

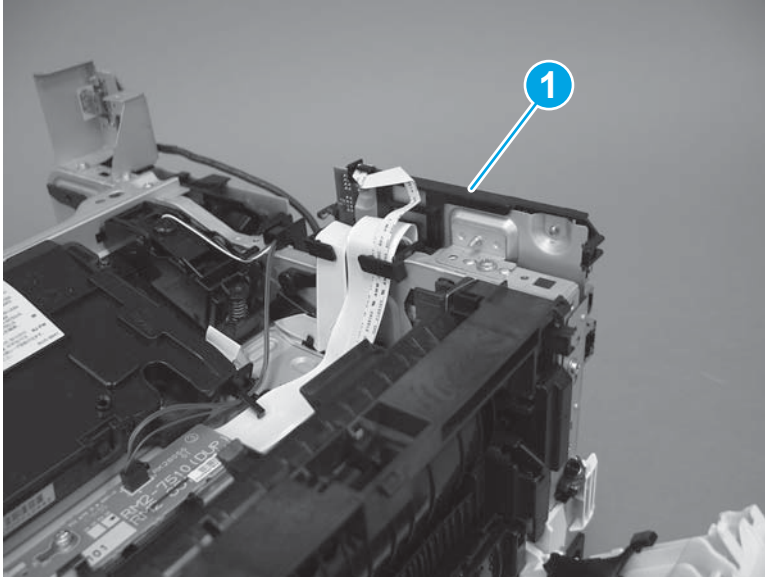

2. Remove two screws (callout 1).

Figure 1-1398 Remove two screws

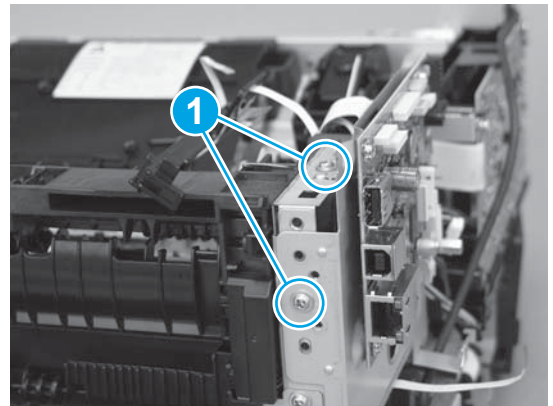
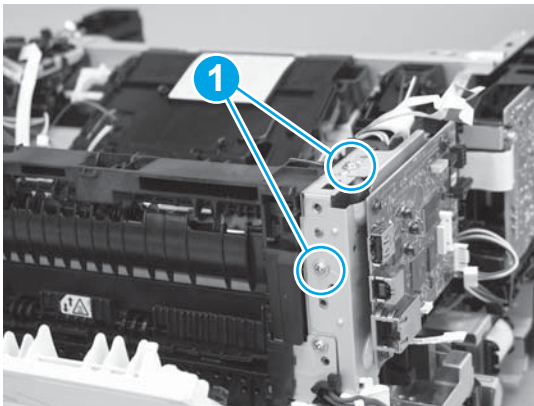

3. Disconnect one connector (callout 1), and then release the wire harness from the guide (callout 2).

Figure 1-1399 Disconnect one connector

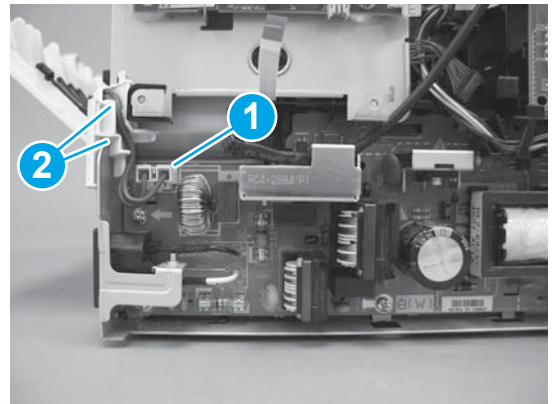
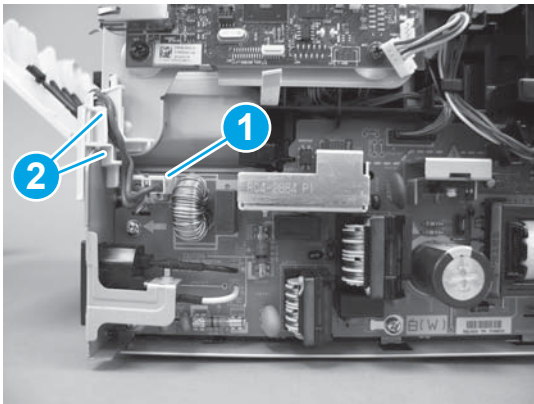

4. Remove the guide (callout 1).

Figure 1-1400 Remove the guide

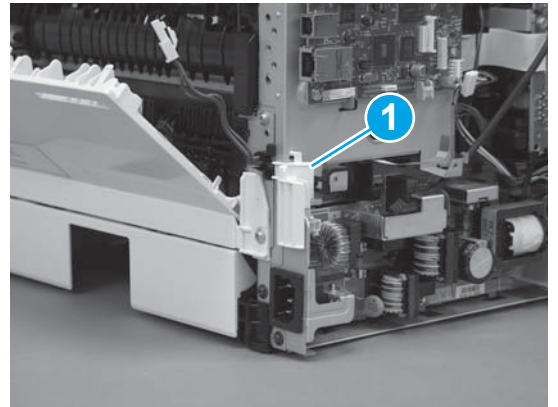
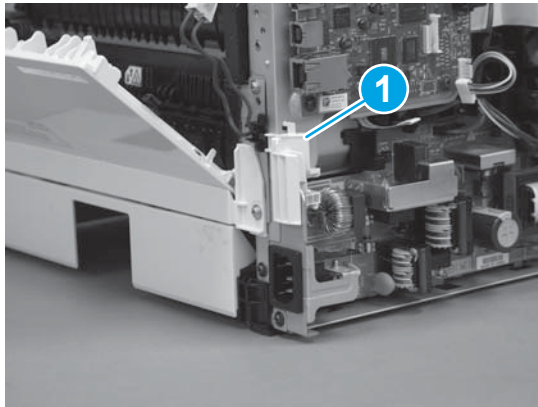

5. Remove three screws (callout 1).

Figure 1-1401 Remove three screws

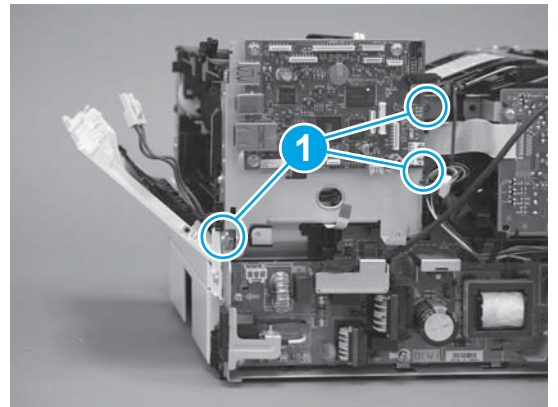
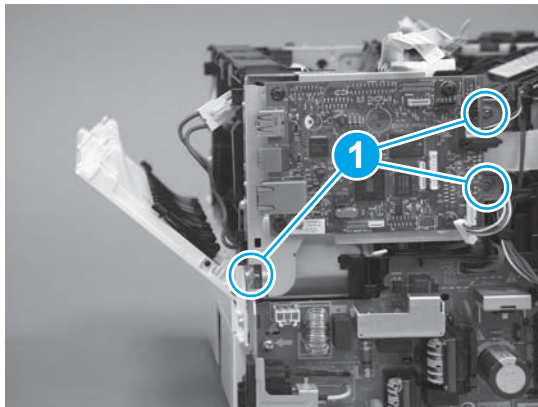

6. Remove the sheet-metal bracket and formatter PCA.

Figure 1-1402 Remove the bracket

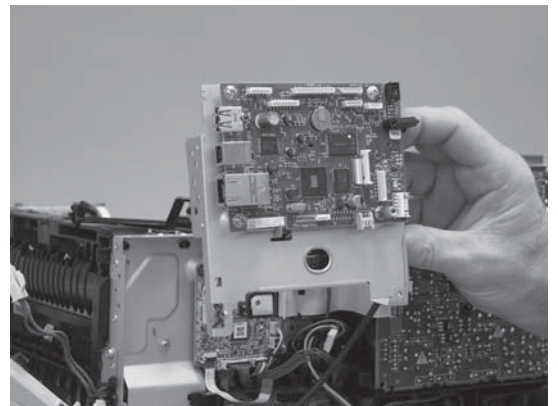
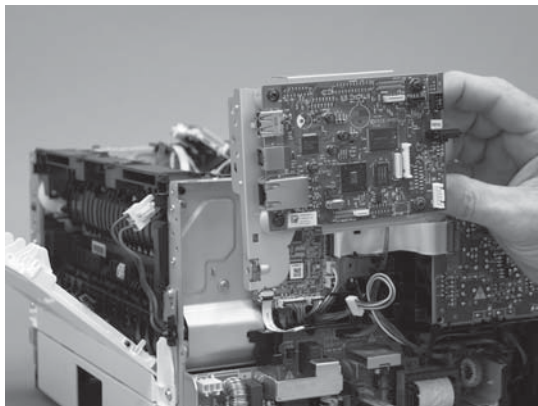

Step 16: Install the paper delivery tray (output bin)

 **NOTE:** This procedure shows the M403/M402 model, however, the paper delivery tray (output bin) removal is similar for the M427/M426 printer.

- ▲ Position the remove the paper delivery tray (output bin; callout 1) on the printer, engage two tabs (callout 2), and then engage two bosses (callout 3).

Figure 1-1403 Engage two tabs

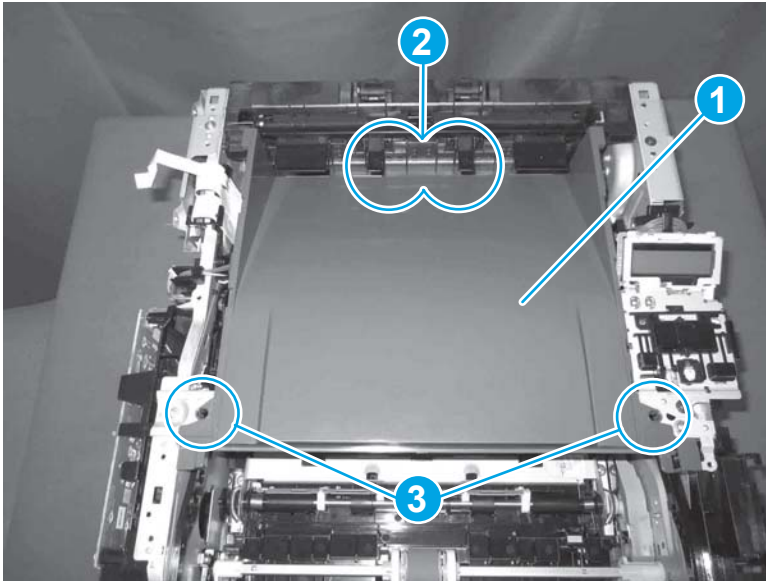

Step 17: Install the top cover (M403/M402)

 **NOTE:** The step is for the M403/M402 printer. For the M427/M426, skip this step and go to [Step 18: Install the top cover \(M427/M426\) on page 756](#).

1. Position the rear edge of the cover on the printer.

Figure 1-1404 Install the cover

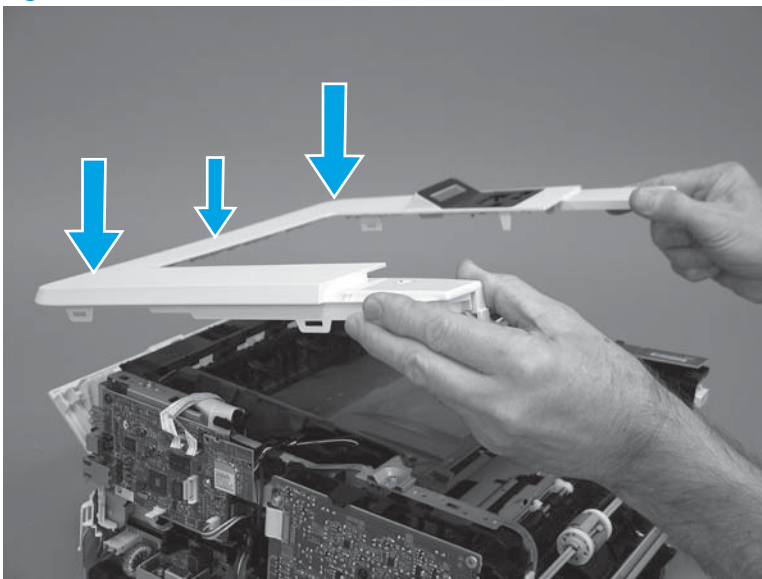

2. Engage four bosses (callout 1), rotate the front of the cover down (callout 2) and onto from the printer, and then engage four tabs (callout 3).

Figure 1-1405 Engage four bosses and tabs

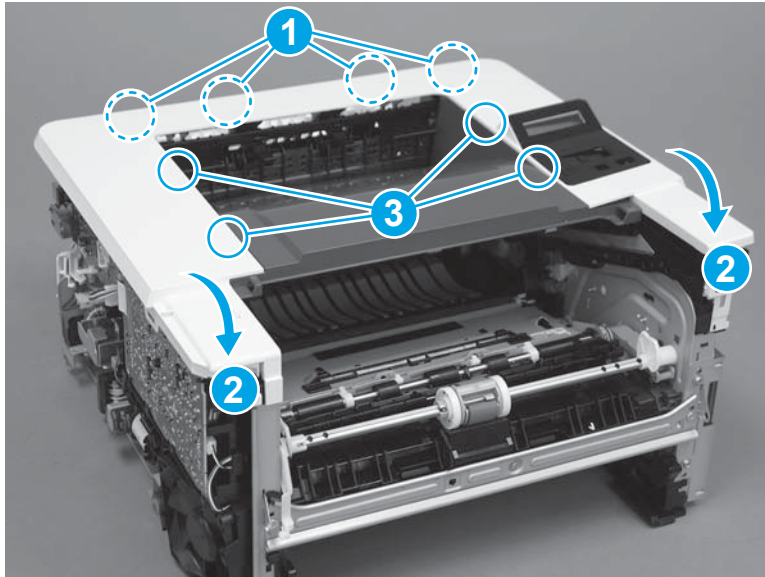

3. At the right side of the printer, engage the one boss and one tab (callout 1).

Figure 1-1406 Engage one boss and one tab

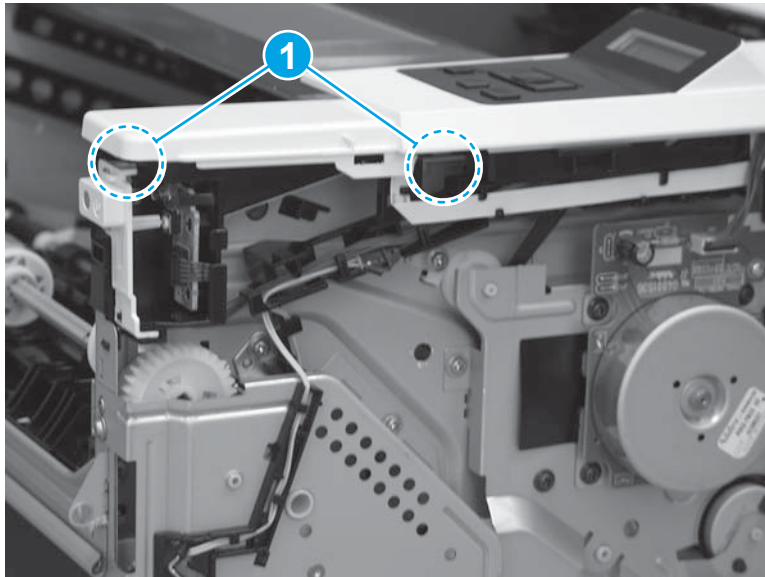

4. Install one screw (callout 1).

Figure 1-1407 Install one screw

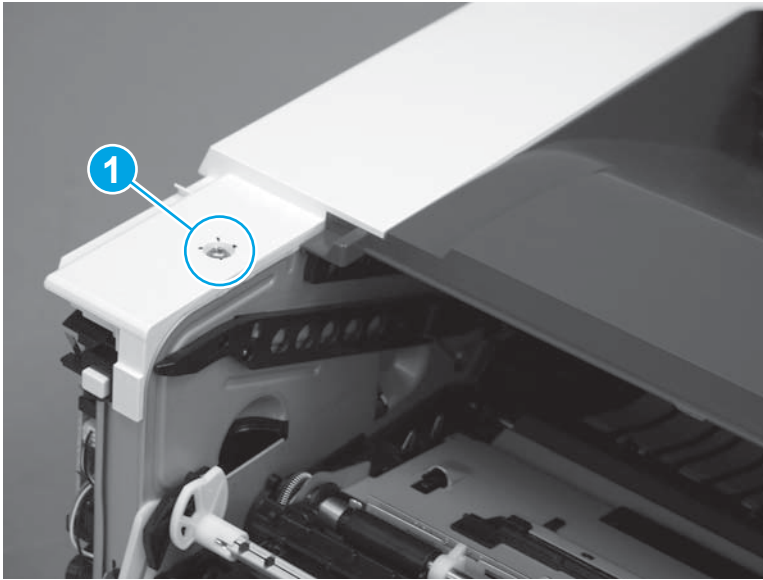

Step 18: Install the top cover (M427/M426)

 **NOTE:** The step is for the M427/M426 printer. For the M403/M402, skip this step and go to [Step 21: Install the rear door assembly on page 767](#).

1. Position the rear edge of the top cover on the printer.

Figure 1-1408 Install the cover

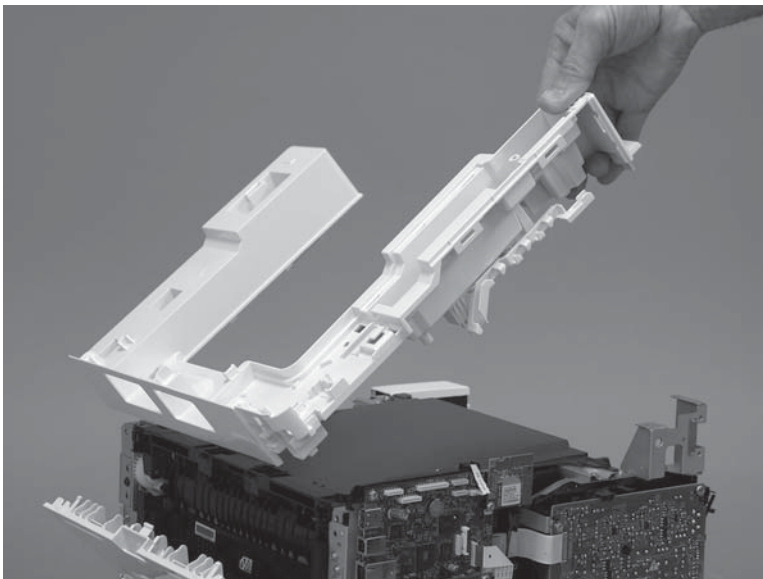

2. Engage four bosses (callout 1).

Figure 1-1409 Engage four bosses

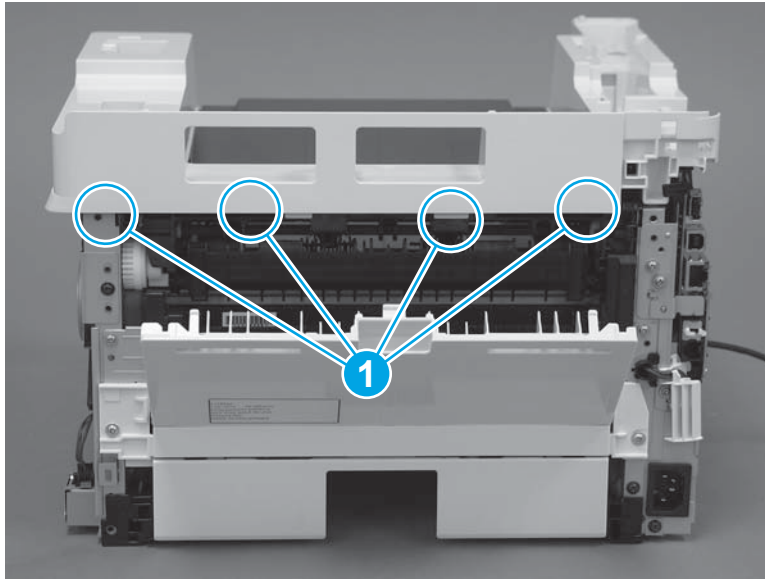

3. Rotate the front edge of the cover down.

Figure 1-1410 Rotate the front edge of the cover down

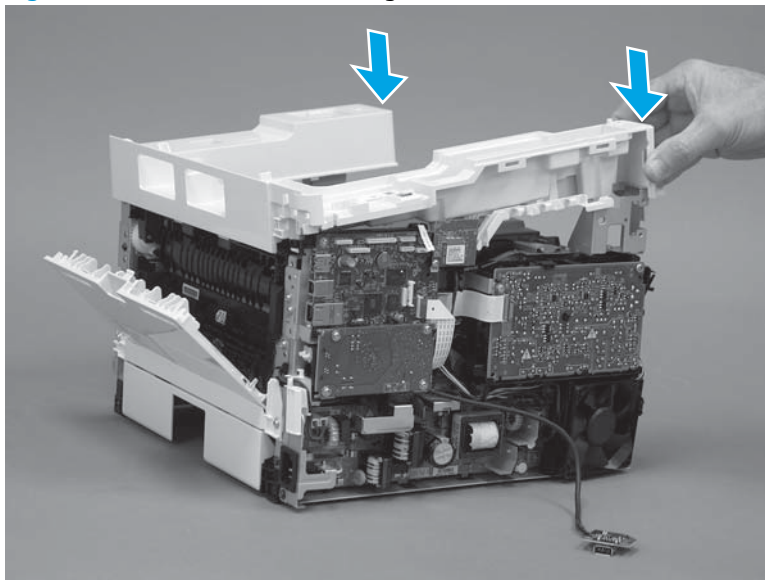

4. Install the USB cable (callout 1) in the guide.

Figure 1-1411 Install the USB PCA

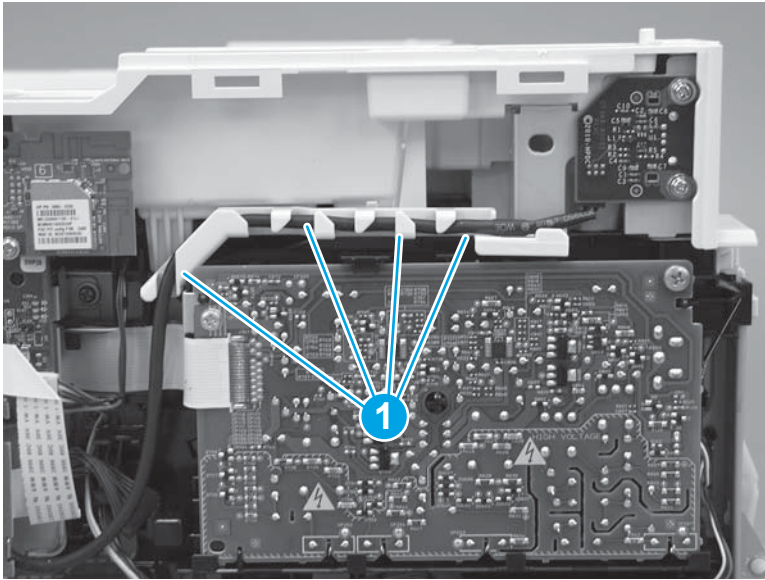

5. Install five screws (callout 1).

Figure 1-1412 Install five screws

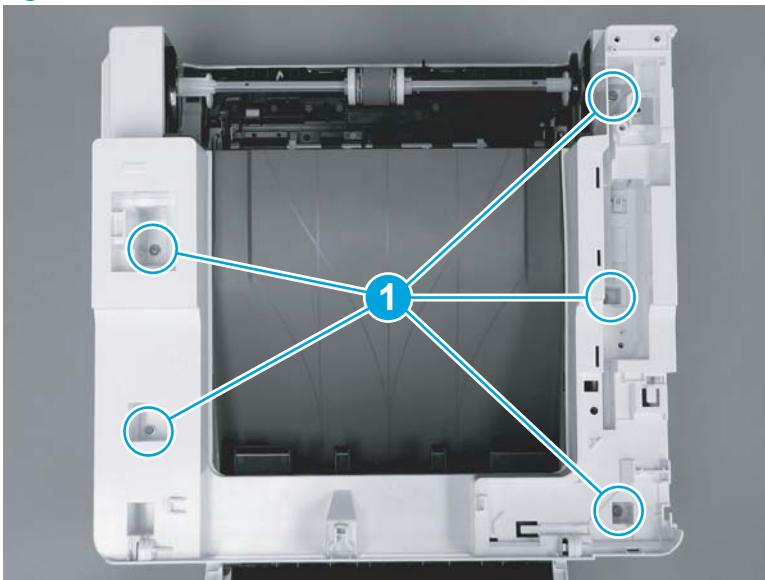

Step 19: Install the control panel (M427/M246)

 **NOTE:** The step is for the M427/M426 printer. For the M403/M402, skip this step and go to [Step 21: Install the rear door assembly on page 767](#).

1. Slide the control-panel FFC cover into the slot in the top cover (next to the document feeder support arm) to install it.

Figure 1-1413 Install the control-panel FFC cover

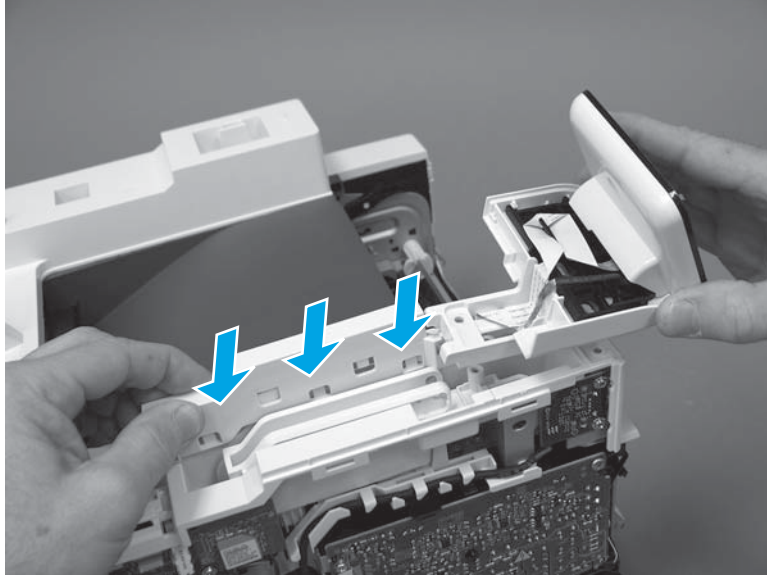

2. Install the control-panel assembly on the top cover.

Figure 1-1414 Install the control-panel assembly

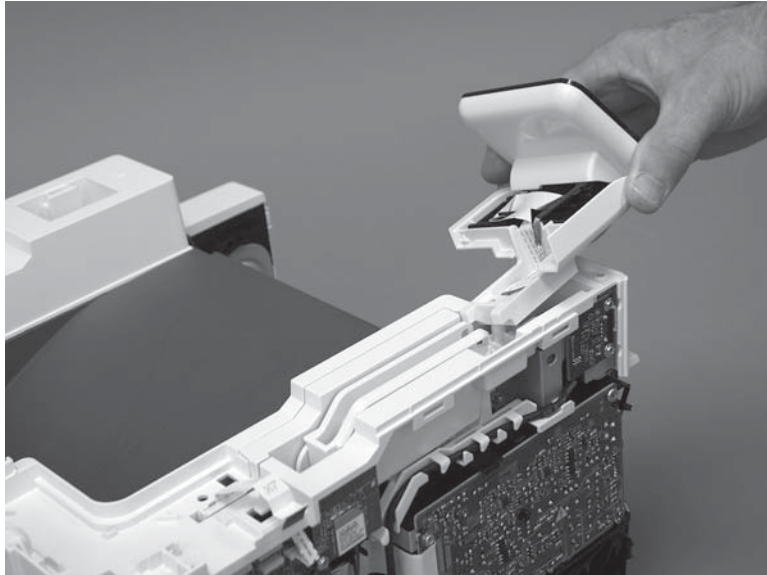

3. Move the FFC out of the way, and then install two screws (callout 1).

Figure 1-1415 Install two screws

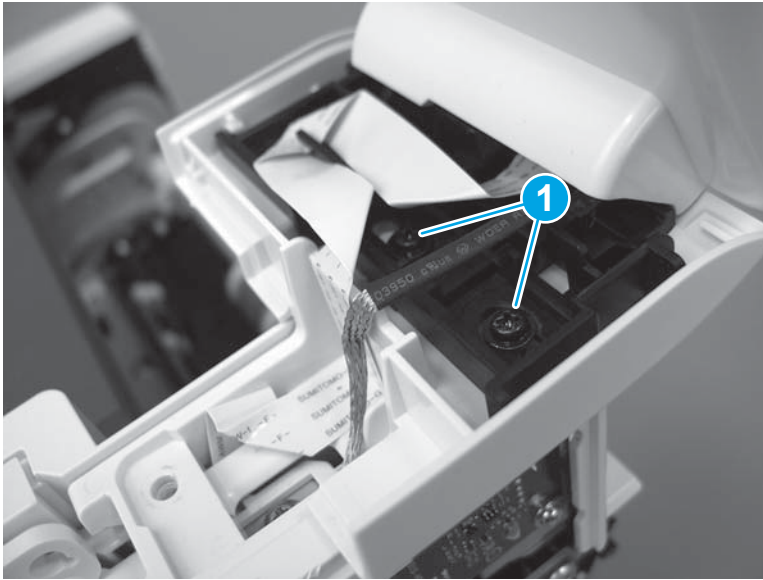

4. Install one grounding screw (callout 1), and then make sure that the ground cable (callout 2) is properly routed.

Figure 1-1416 Remove one screw

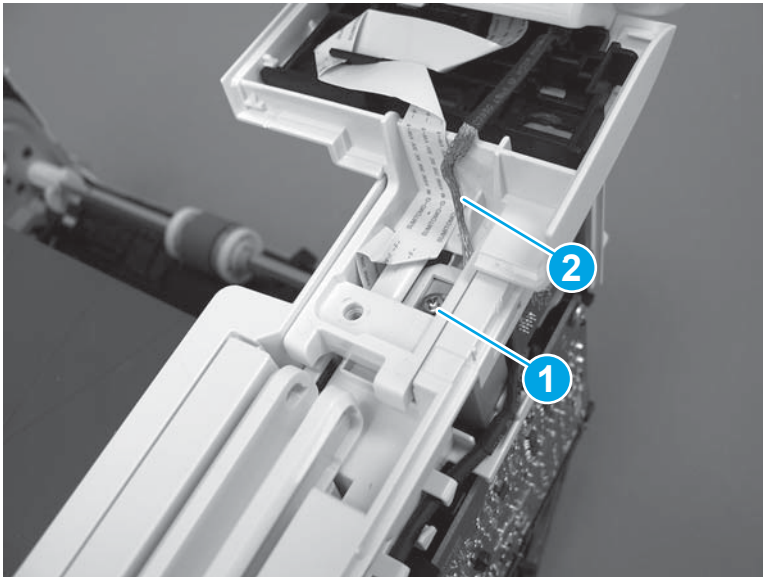

5. Install the control-panel cable cover.

Figure 1-1417 Install the cover

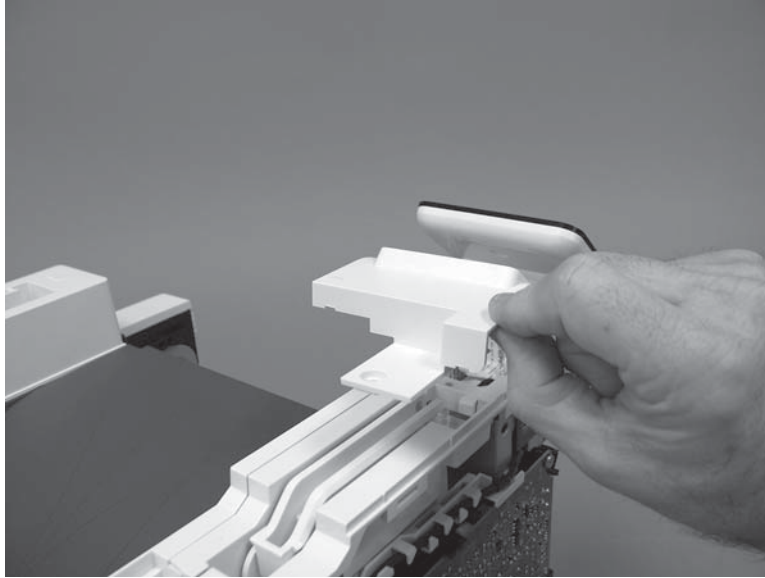

6. Make sure that the two tabs (callout 1) on the cover snap into place.

Figure 1-1418 Engage two tabs

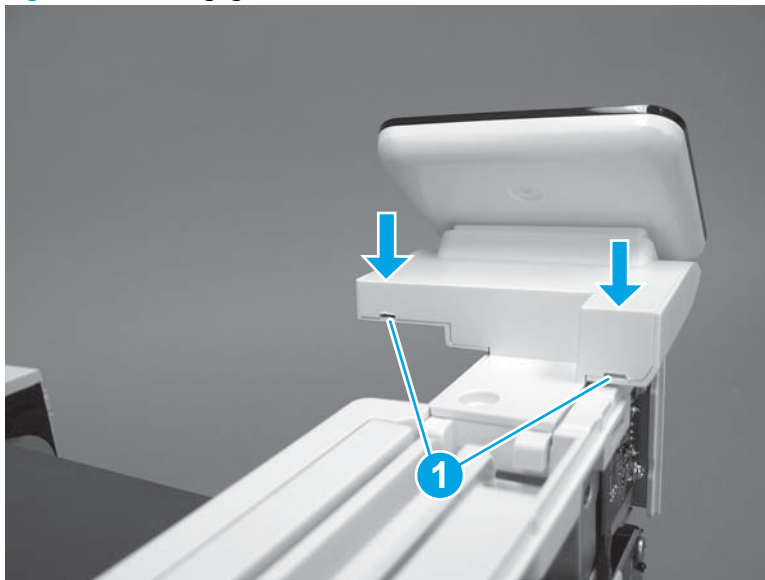

7. Install one screw (callout 1).

Figure 1-1419 Install one screw

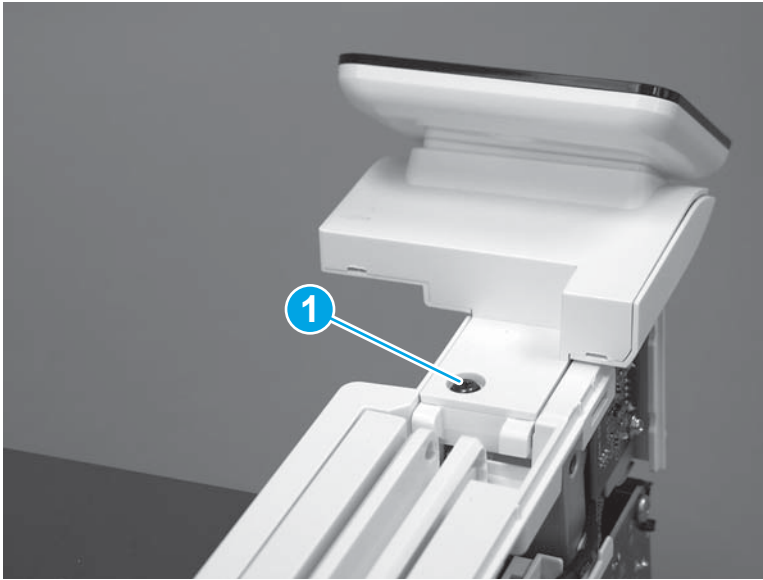

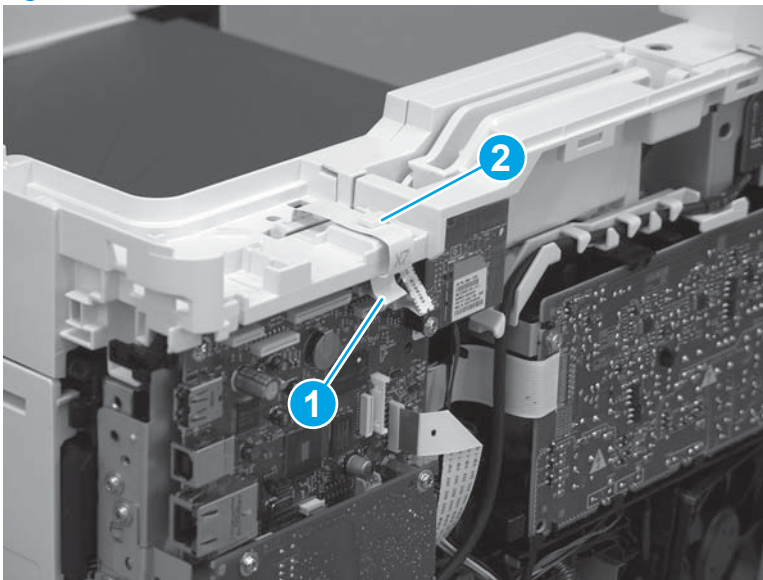

8. Install the FFC in the retainer (callout 1), and then connect one FFC (callout 1; J114).

Figure 1-1420 Connect one connector



Step 20: Install the integrated scanner assembly (M427/M246)

 **NOTE:** The step is for the M427/M426 printer. For the M403/M402, skip this step and go to [Step 21: Install the rear door assembly on page 767](#).

 **NOTE:** M427/M426 models only. The integrated scanner assembly (ISA) includes the sub-scanner assembly (SSA) and the automatic document feeder (ADF).

1. Position the ISA on the printer.

Figure 1-1421 Position the ISA on the printer

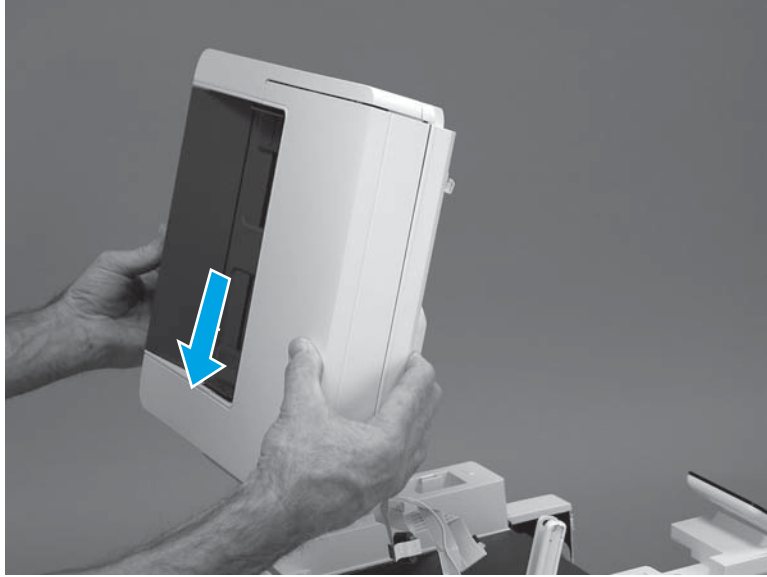

2. Engage the hinge pins on the ISA with the holders in the top cover (callouts 1/2), and then slide the ISA as shown to engage them

Figure 1-1422 Engage the hinge pins with the holders

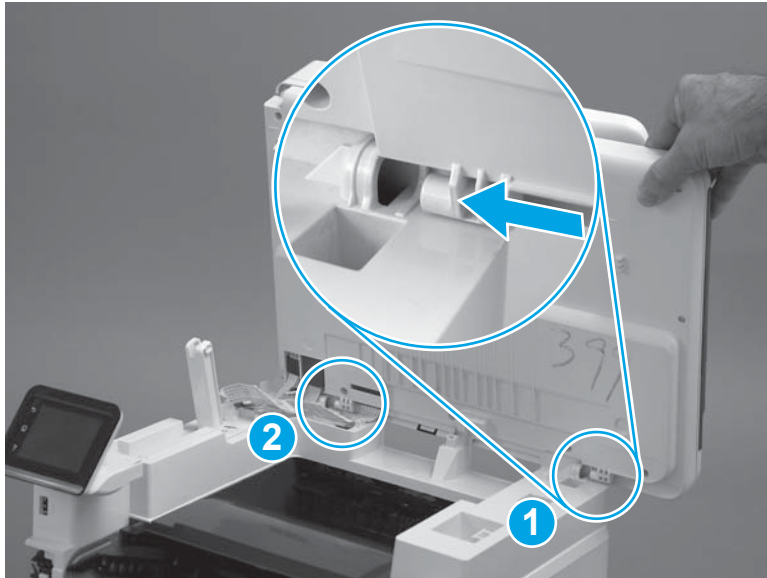

3. Rotate the ISA towards the front of the printer until it rests on the ISA lift assembly (callout 1).

Figure 1-1423 Rotate the ISA towards the front of the printer

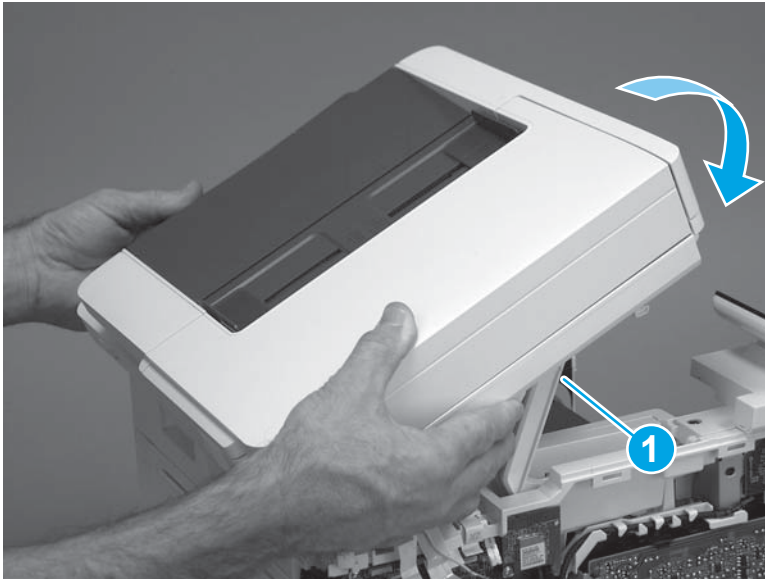

4. Pass the ground wire through the opening in the top cover.

Figure 1-1424 Pass the wire through the opening

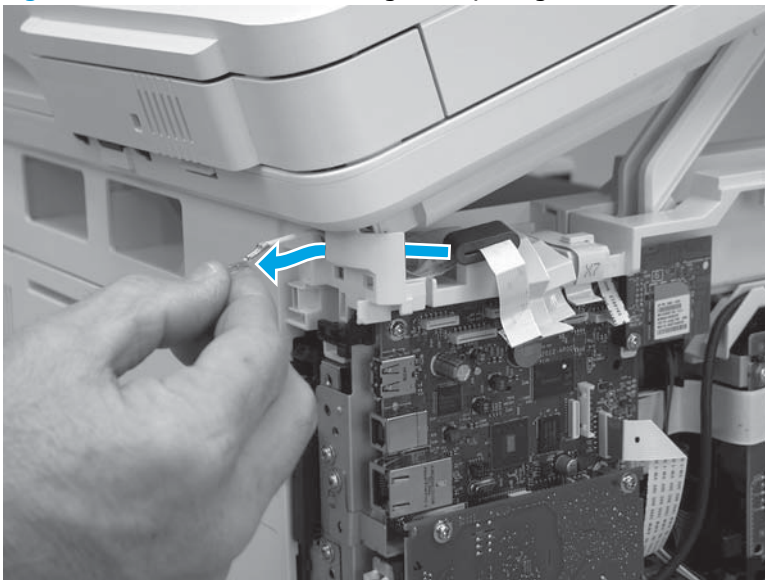

5. Install one screw (callout 1).

Figure 1-1425 Install one screw

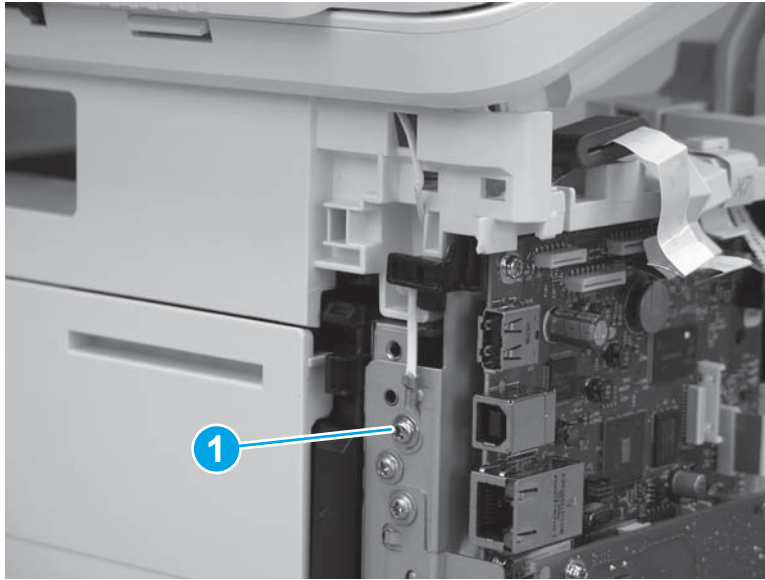

6. Install the ISA lift assembly slider pin.

 **Reinstallation tip:** Align the keyed portion of the locking pin with the slot and hole in the support arm.

Figure 1-1426 Install the slider pin



7. Rotate the slider pin (callout 1) towards the rear of the printer until the tab (callout 2) snap into place.

Figure 1-1427 Secure the slider pin

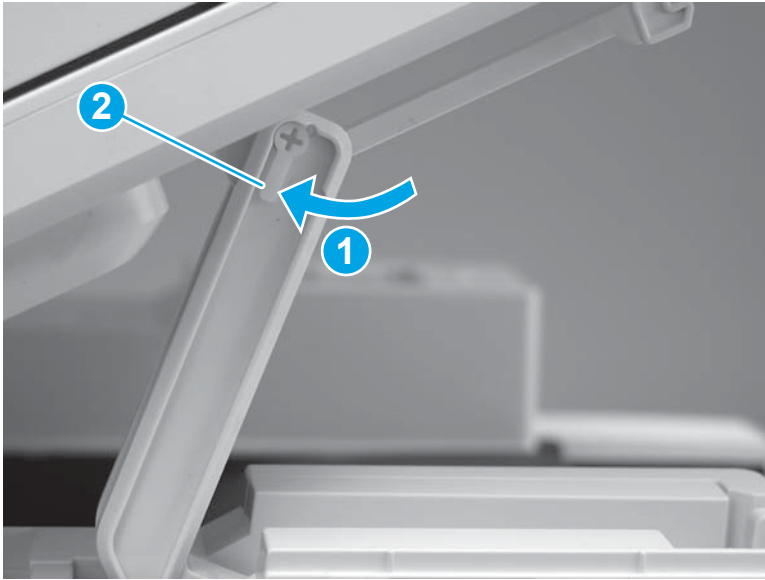

8. Install the ferrite (callout 1) in the holder, and then connect three FFCs (callout 2).

Figure 1-1428 Connect three FFCs

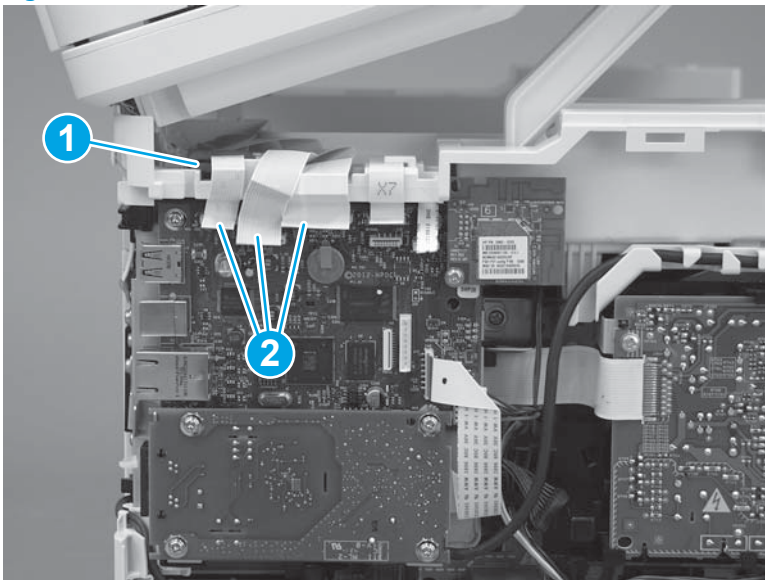

9. Position the rear edge of the ISA flat-flexible cable (FFC) cover on the printer (callout 1) , and then rotate it down (callout 2) until it snaps into place.

Figure 1-1429 Install the ISA FFC cover

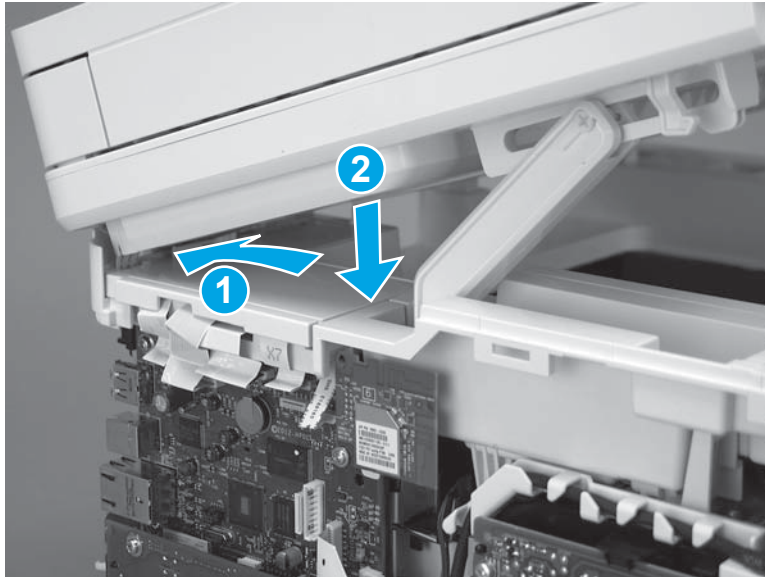

10. Lower the ISA.

Figure 1-1430 Lower the ISA

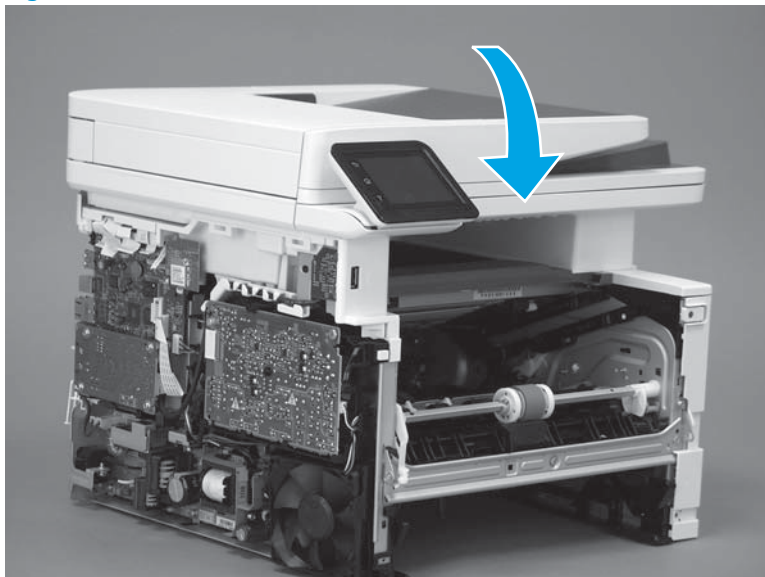

Step 21: Install the rear door assembly

1. At the rear of the printer, position the assembly so that the two tabs (callout 1) are installed in the slots (callout 2) in the chassis.

 **NOTE:** Duplex models only: Slide the duplex tray into the Tray 2 cavity.

Figure 1-1431 Install the rear cover



2. Install two screws.

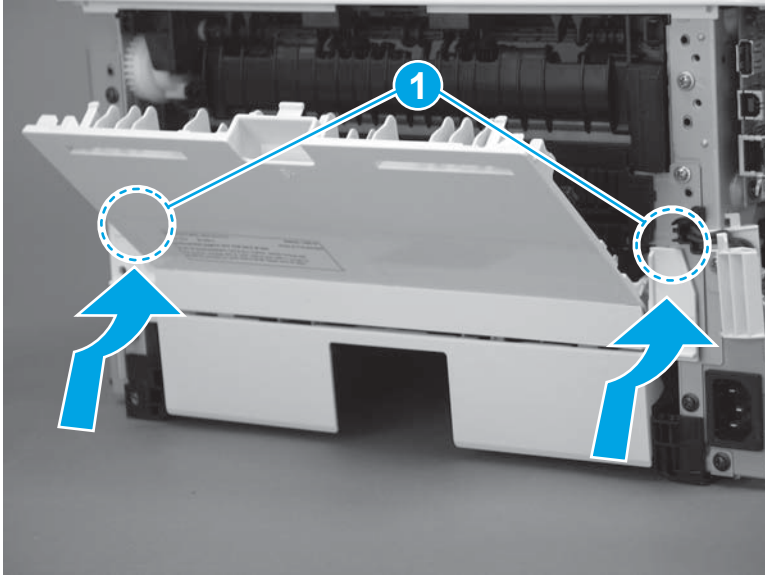

NOTE: Duplex models only: Reach in from the front of the Tray 2 cavity and raise the feed assembly to the up and locked position so that the rear cover will fit flat against the chassis.

Figure 1-1432 Install two screws



Step 22: Install the right cover

1. Position the cover (callout 1) on the printer, and then engage two bosses (callout 2).

Figure 1-1433 Install the cover

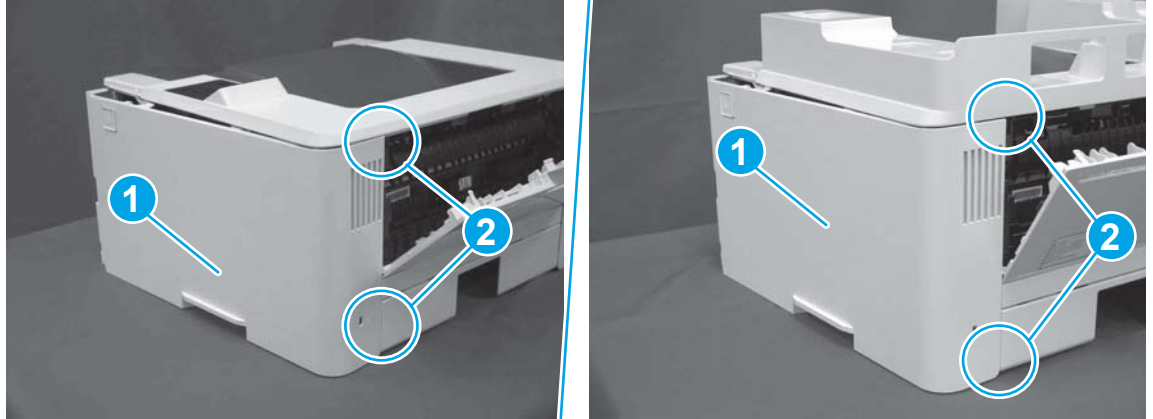

2. Rotate the front of the cover onto the printer (callout 1), engage three (callout 2) tabs, and then engage two bosses (callout 3).

Figure 1-1434 Engage two bosses and one tab

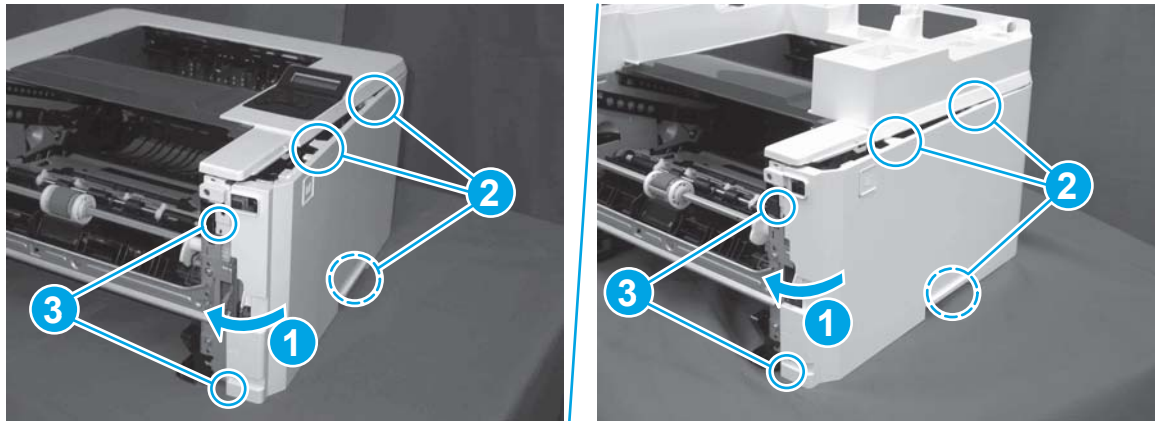

3. Make sure that the power switch (callout 1) and cartridge door assembly button (callout 2) correctly function.



NOTE: Remove, and then reinstall the cover if the switch or button does not correctly function.

Figure 1-1435 Check the power switch and cartridge door assembly button

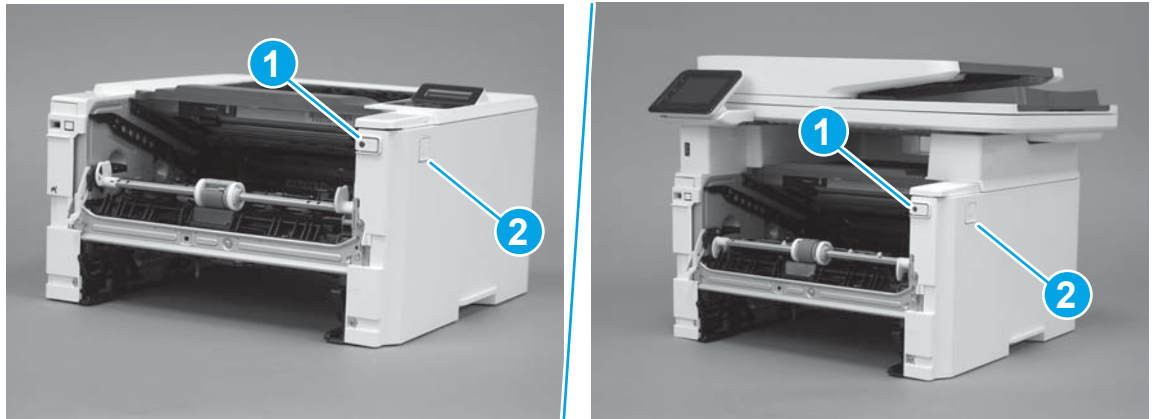

4. Install one screw (callout 1).

Figure 1-1436 Install one screw



Step 23: Install the left cover

1. At the front of the printer, do one of the following:
 - **M403/M402:** Position the cover on the printer (callout 1), and then engage two bosses (callout 2).
 - **M427/M426:** Position the cover on the printer (callout 3), engage one tab (callout 4), and then engage two bosses (callout 4).

Figure 1-1437 Install the cover

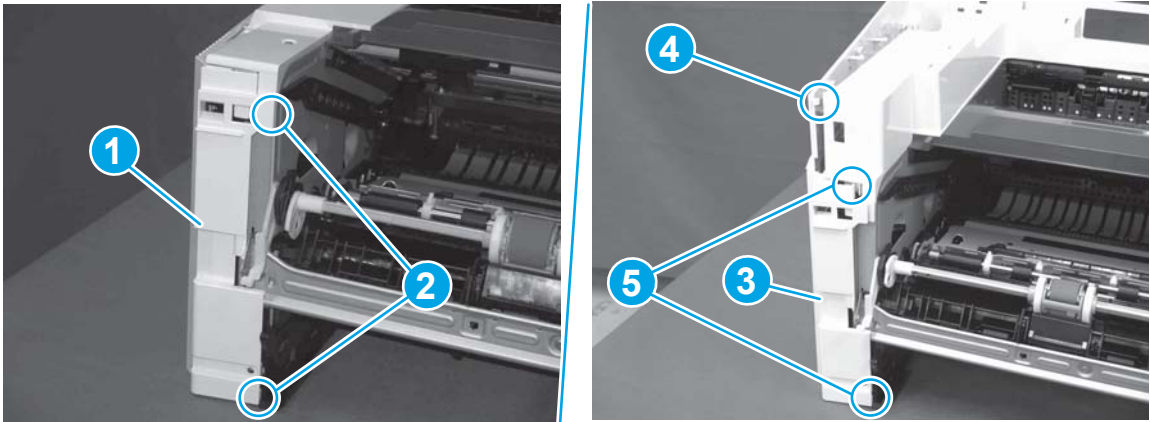

- Carefully rotate the rear of the cover onto the printer (callout 1), engage three tabs (callout 2), and then engage two bosses (callout 3).

Figure 1-1438 Engage three tabs and two bosses

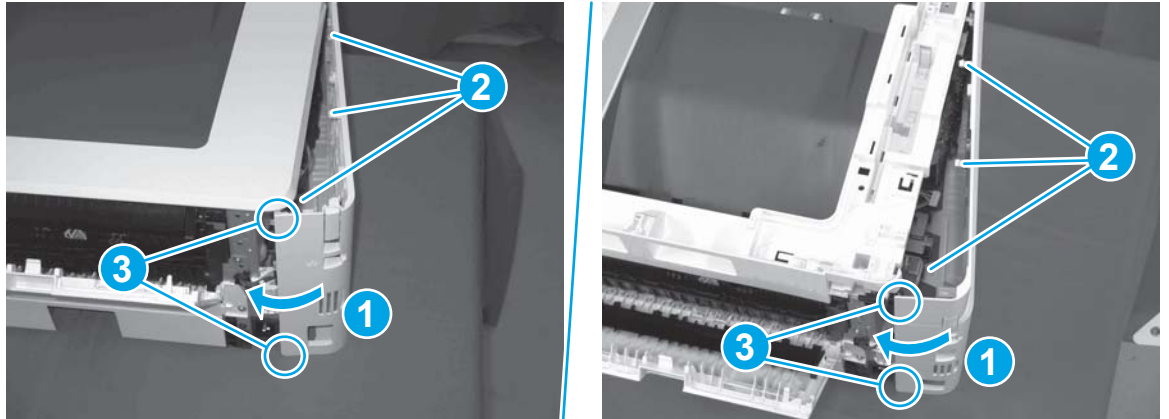

- Install one screw (callout 1).

Figure 1-1439 Install one screw

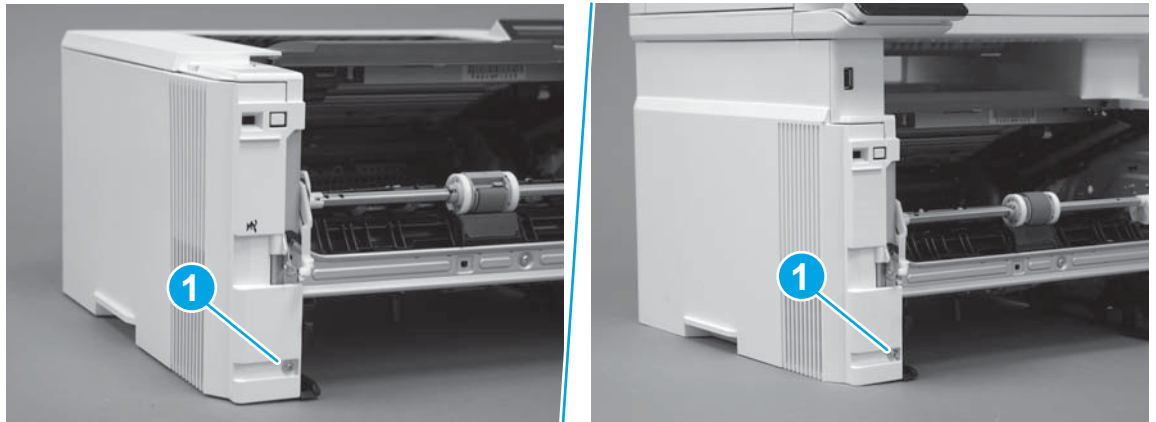

Step 24: Install the cartridge door assembly

 **Reinstallation tip:** After a replacement door is installed, make sure to install the nameplate (supplied in the kit) corresponding to the printer name on the door.

- Position the door close to the printer, and then engage the keyed pin on the left-side retainer arm with the hole in the door.

Figure 1-1440 Engage the left-side retainer arm

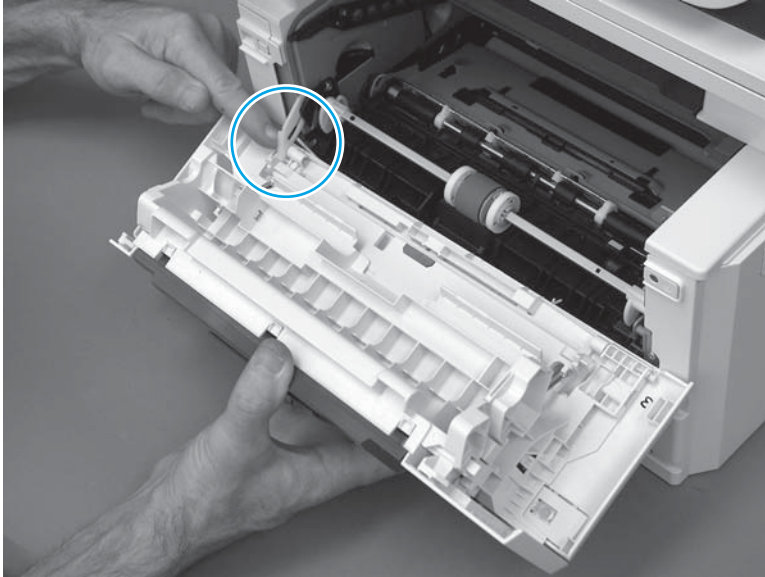

2. Engage the right-side door hinge pin with the hole in the chassis (callout 1).

Figure 1-1441 Install the door

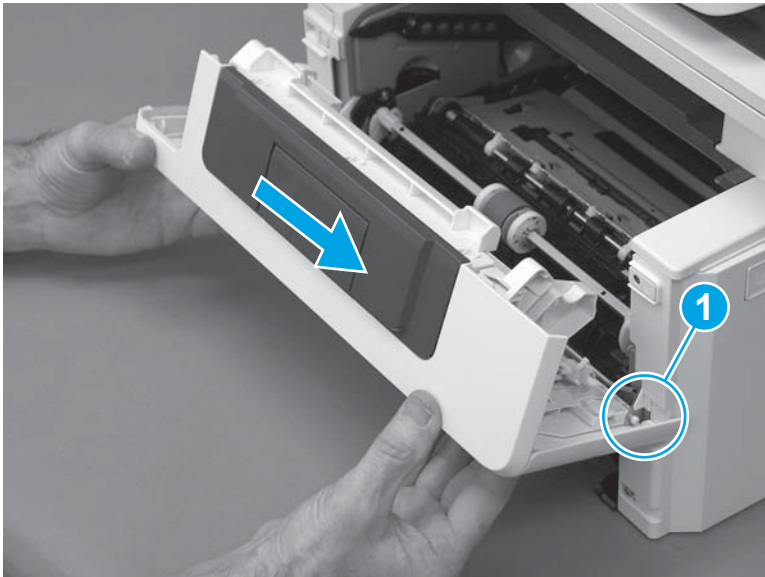

3. Install the link (callout 1).

 **IMPORTANT:** Make sure that the link snaps into place on the arm (callout 2). The link actuates the fuser pressure-release mechanism.

Figure 1-1442 Install the pressure-release link

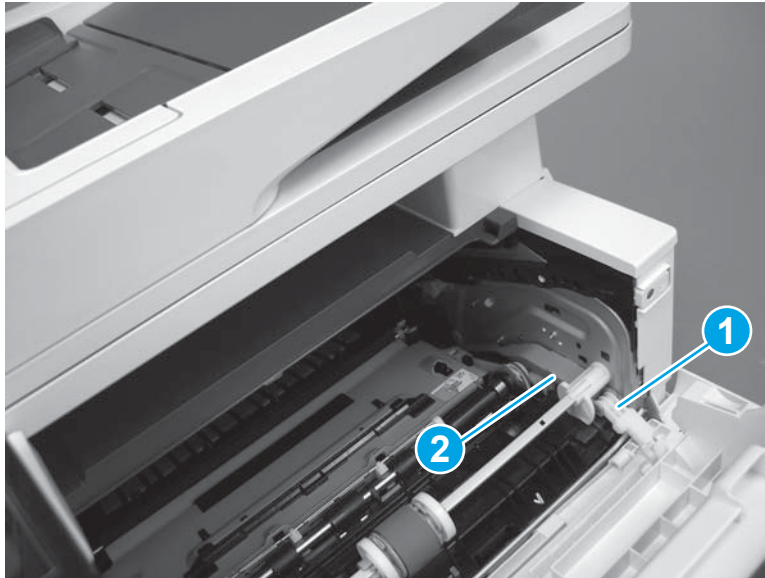

4. Slide the guide into the printer (callout 1), and then make sure that the tab (callout 2) snaps into place to secure the guide to the chassis.

Figure 1-1443 Install the guide

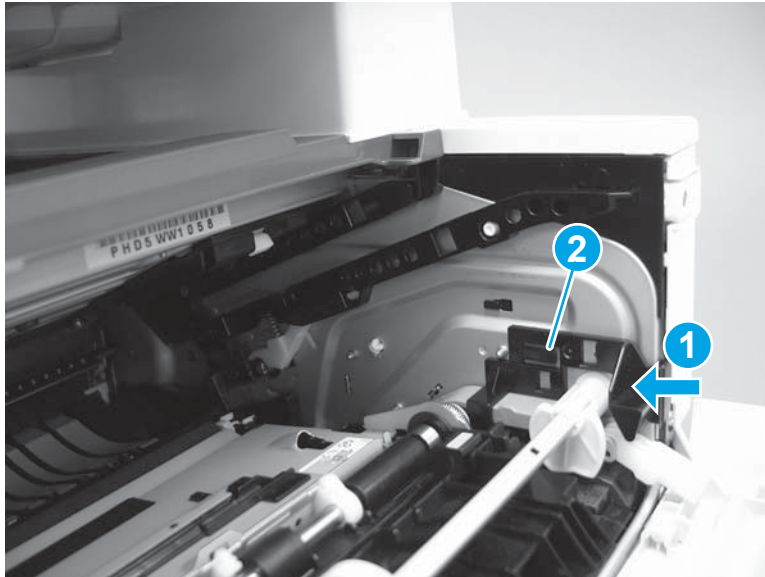

5. Position the shaft on the door, and then align the left-side hinge on the door with the hole in the chassis (callout 1).

Figure 1-1444 Align the hinge

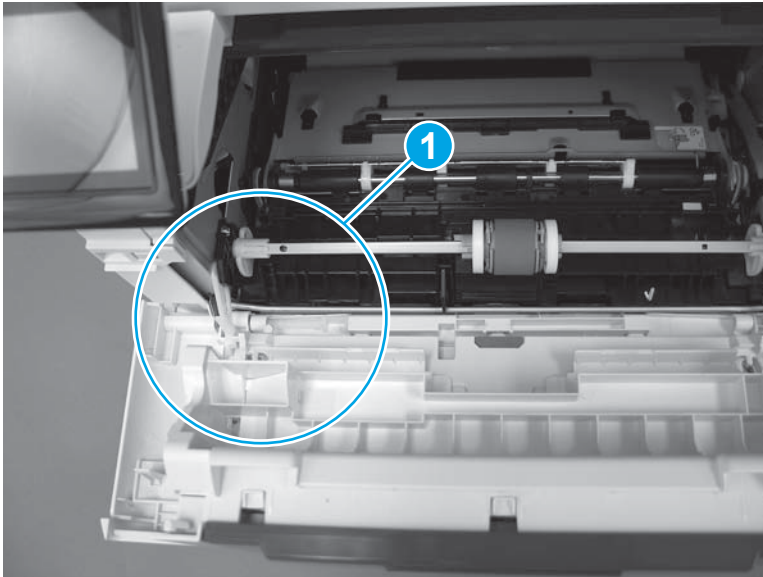

6. Push the shaft towards the left side of the printer to install it (callout 1).

 **Reinstallation tip:** Make sure that the support shaft is fully installed and correctly orientated (callout 2) so that it will not interfere with the door opening and closing.

Figure 1-1445 Install the support shaft



Step 25: Install Tray 2

- ▲ Slide the tray straight into the printer to install it.

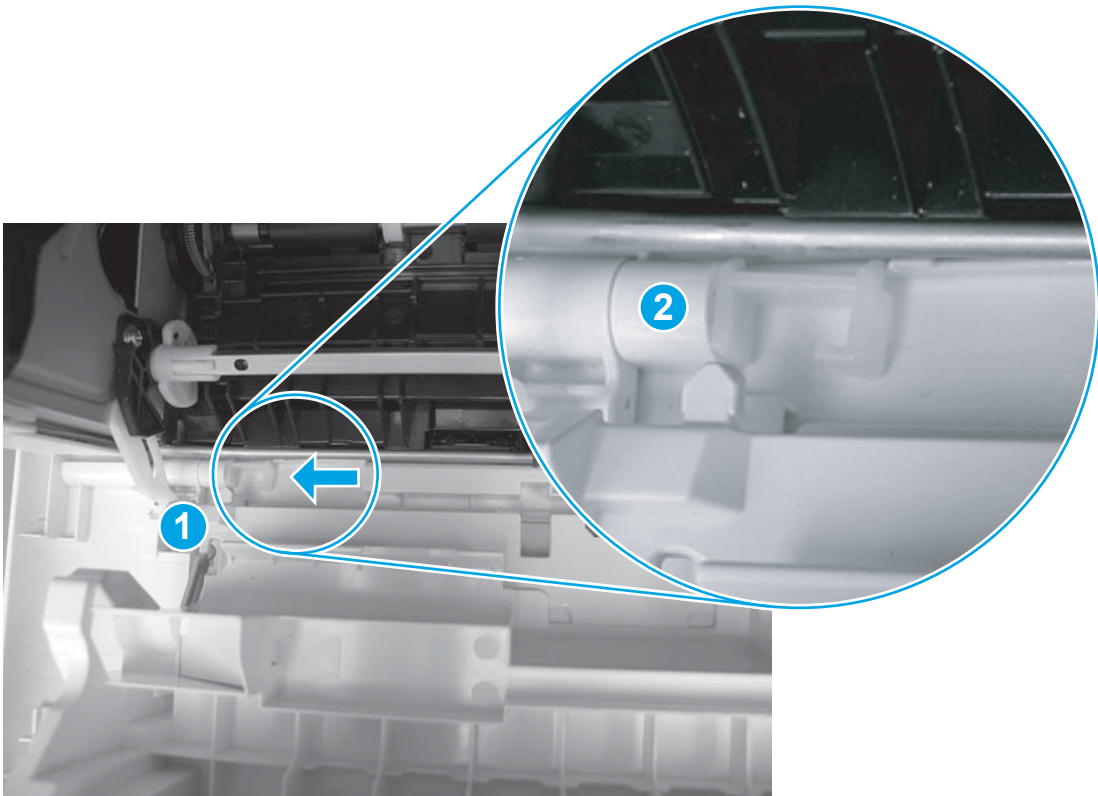
Figure 1-1446 Install the tray



Removal and replacement: Tag-cable assembly (toner-cartridge memory)

- [Introduction](#)
- [Step 1: Remove Tray 2](#)
- [Step 2: Remove the cartridge door assembly](#)
- [Step 3: Remove the left cover](#)
- [Step 4: Remove the right cover](#)
- [Step 5: Remove the integrated scanner assembly \(M427/M246\)](#)
- [Step 6: Remove the control panel \(M427/M246\)](#)
- [Step 7: Remove the top cover \(M427/M426\)](#)
- [Step 8: Remove the top cover \(M403/M402\)](#)
- [Step 9: Remove the paper delivery tray \(output bin\)](#)
- [Step 10: Remove the sheet-metal formatter bracket and formatter PCA](#)
- [Step 11: Remove the tag-cable assembly \(toner-cartridge memory\)](#)
- [Step 12: Unpack the replacement assembly](#)
- [Step 13: Install the tag-cable assembly \(toner-cartridge memory\)](#)
- [Step 14: Install the sheet-metal formatter bracket and formatter PCA](#)
- [Step 15: Install the paper delivery tray \(output bin\)](#)
- [Step 16: Install the top cover \(M403/M402\)](#)
- [Step 17: Install the top cover \(M427/M426\)](#)
- [Step 18: Install the control panel \(M427/M246\)](#)
- [Step 19: Install the integrated scanner assembly \(M427/M246\)](#)
- [Step 20: Install the right cover](#)
- [Step 21: Install the left cover](#)
- [Step 22: Install the cartridge door assembly](#)
- [Step 23: Install Tray 2](#)

Introduction

This document provides the procedures to remove and replace the tag-cable assembly (toner-cartridge memory).

Before performing service

Turn the printer power off

- Disconnect the power cable.

⚠ WARNING! To avoid damage to the printer, turn the printer off, wait 30 seconds, and then remove the power cable before attempting to service the printer.

Use the table below to identify the correct part number for your printer. To order the part, go to www.hp.com/buy/parts.

Tag-cable assembly (toner-cartridge memory) part number	
RM2-5426-000CN	Tag-cable assembly (toner-cartridge memory)

Required tools

- #2 Phillips screwdriver with a magnetic tip.
- 5.5 mm (0.22 inch) socket screwdriver.

After performing service

Turn the printer power on

- Connect the power cable.
- Use the power switch to turn the power on.

Post service test

Make sure that the printer initializes to a **Ready** state.

Print a configuration page to make sure that the printer is functioning correctly.

Step 1: Remove Tray 2

- ▲ Pull the tray straight out of the printer to remove it.

Figure 1-1447 Remove the tray



Step 2: Remove the cartridge door assembly

 **NOTE:** If the toner cartridge was not removed prior to servicing the printer, remove it now.

1. Release one tab (callout 1), and then slide shaft (callout 2) in the direction the arrow indicates and remove it.

 **TIP:** It might be easier to release the support shaft by using a small flat-blade screwdriver.

Figure 1-1448 Release the support shaft

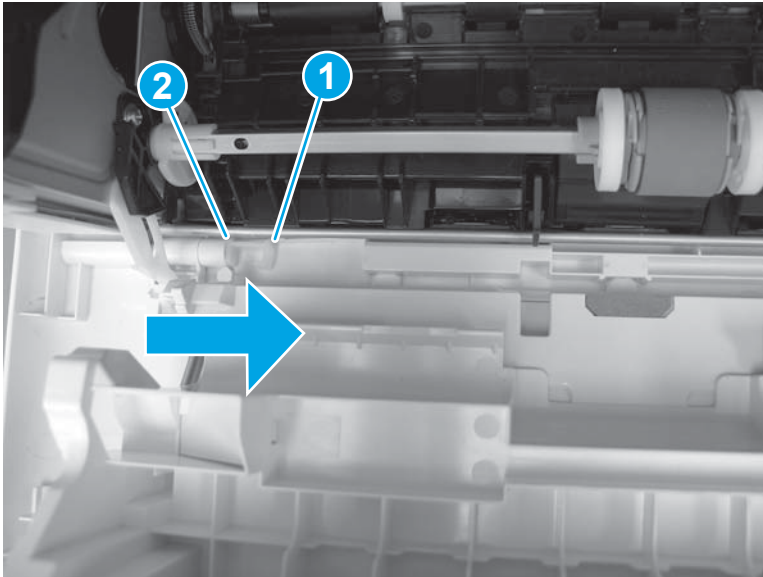

2. Release one tab (callout 1), and then slide the guide (callout 2) in the direction the arrow indicates and remove it.

Figure 1-1449 Remove the guide

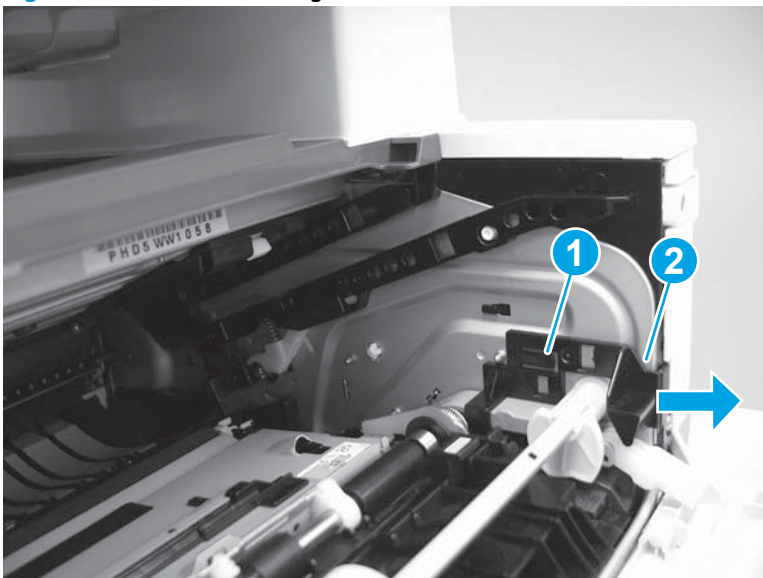

3. Remove the link arm (callout 1).

Figure 1-1450 Remove the link arm

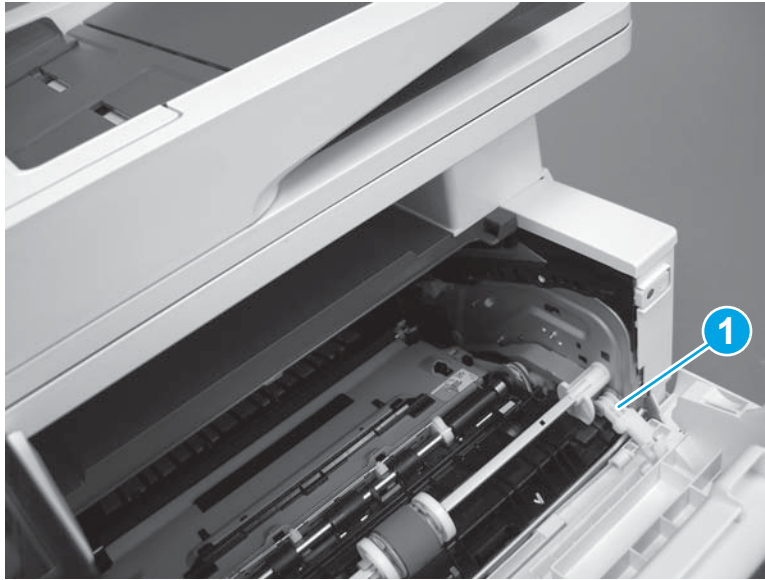

4. Slide the cartridge door assembly (callout 1) in the direction the arrow indicates and remove it.

Figure 1-1451 Remove the door

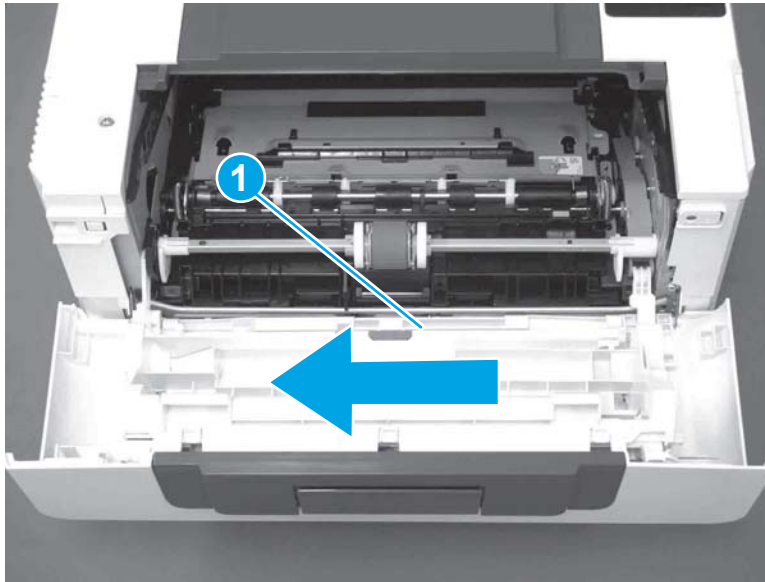

5. Remove the link (callout 1) from the cartridge door assembly (callout 2).

Figure 1-1452 Release the left-side retainer arm

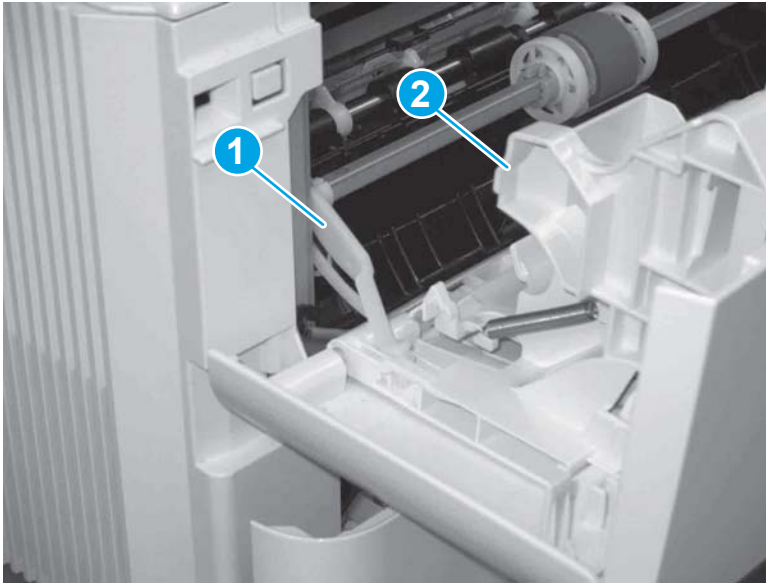

Step 3: Remove the left cover

1. Remove one screw (callout 1).

Figure 1-1453 Remove one screw

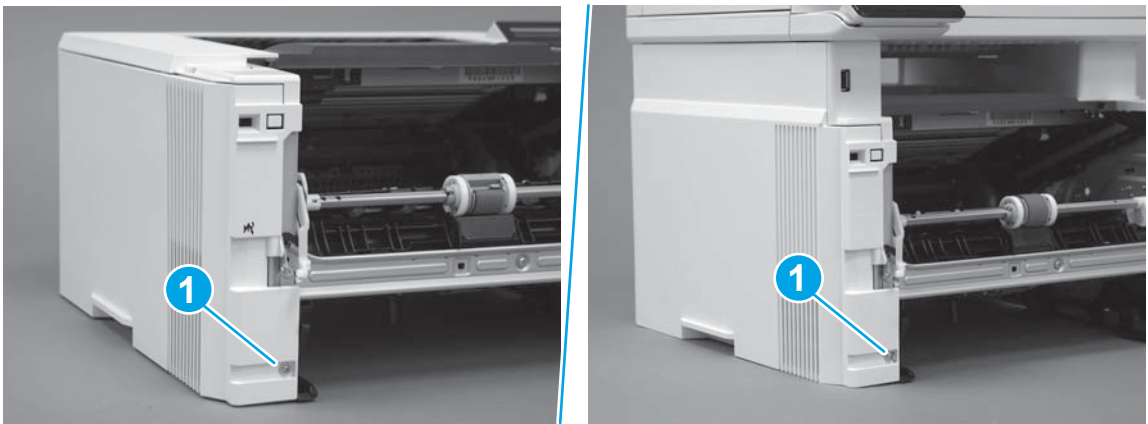

2. Open the rear door, release two bosses (callout 1), and then release three tabs (callout 2).

Figure 1-1454 Release two bosses and three tabs

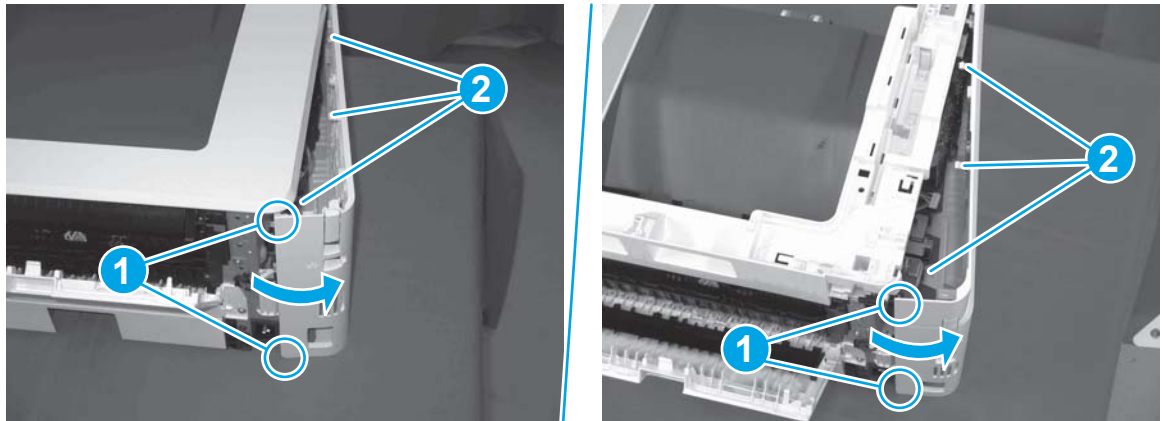

3. At the front of the printer, do one of the following:

- **M403/M402:** Release two bosses (callout 1), and then remove the cover (callout 2).
- **M427/M426:** Release one tab (callout 3), two bosses (callout 4), and then remove the cover (callout 5).

CAUTION: Be careful when releasing the upper bosses on the M427/M426 cover. One portion of the cover (callout 6) is fragile and is easily broken.

Figure 1-1455 Remove the cover

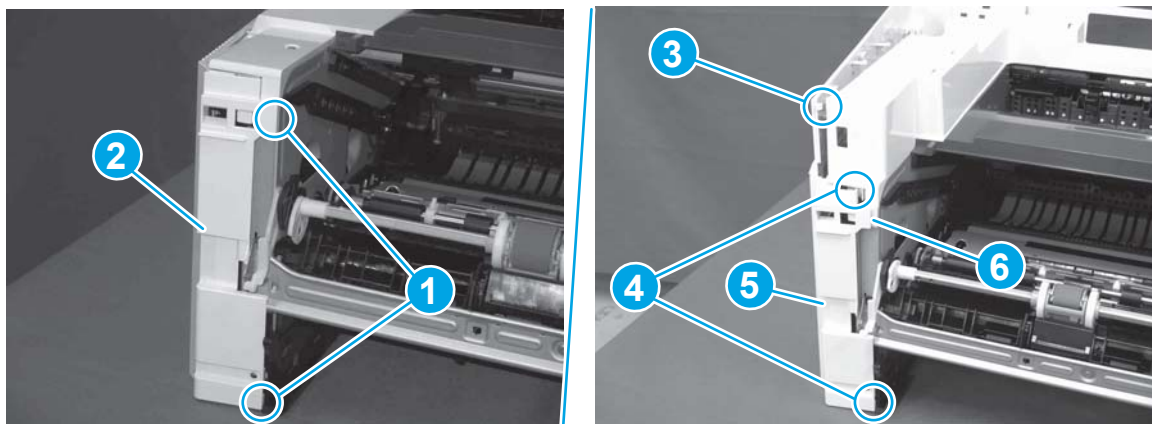

Step 4: Remove the right cover

1. Remove one screw (callout 1).

Figure 1-1456 Remove one screw



2. At the front of the printer, release two bosses (callout 1), and then release three tabs (callout 2).

Figure 1-1457 Release two bosses and three tabs

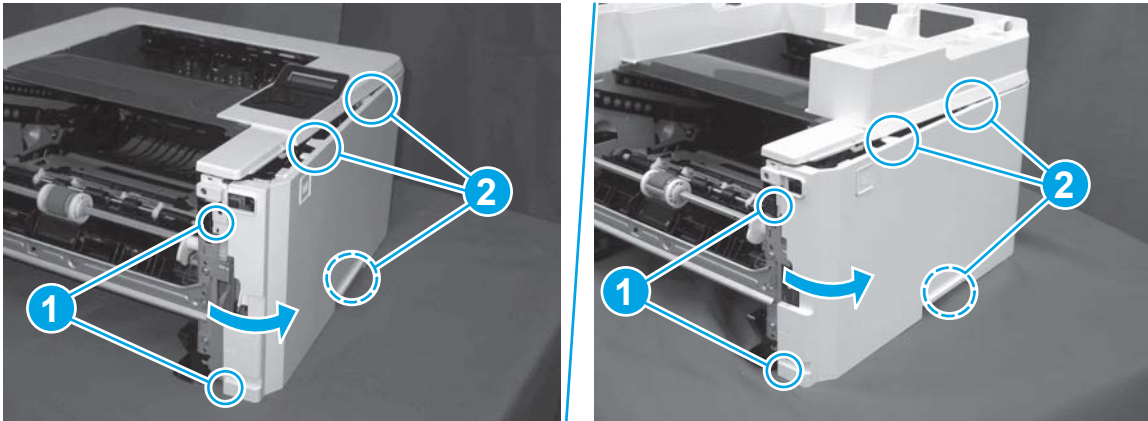

3. Open the rear door, release two bosses (callout 1), and then remove the cover (callout 2).

Figure 1-1458 Remove the cover

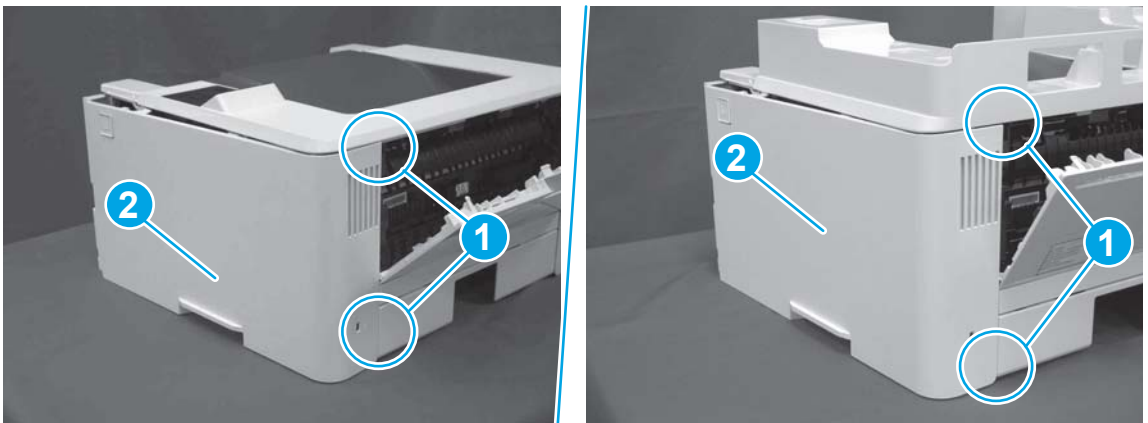

Step 5: Remove the integrated scanner assembly (M427/M246)



NOTE: The step is for the M427/M426 printer. For the M403/M402, skip this step and go to [Step 8: Remove the top cover \(M403/M402\) on page 792](#).

 **NOTE:** M427/M426 models only. The integrated scanner assembly (ISA) includes the sub-scanner assembly (SSA) and the automatic document feeder (ADF).

1. Raise the ISA.

Figure 1-1459 Raise the ISA

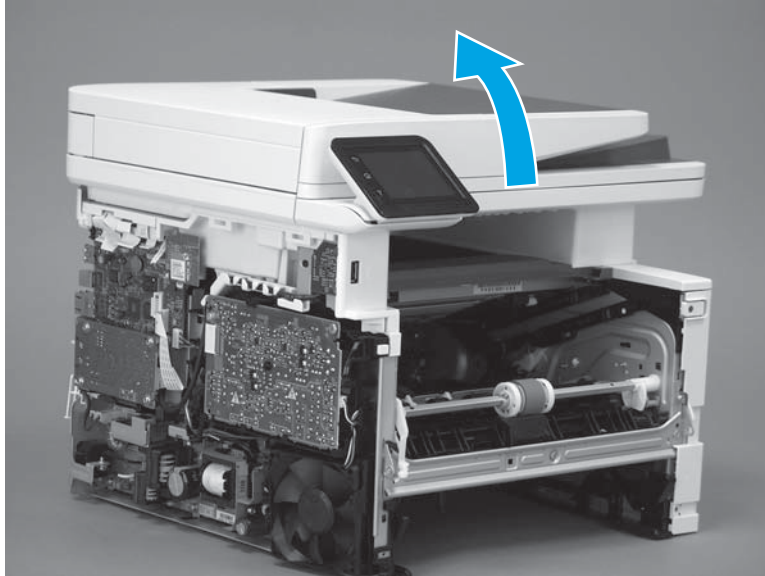

2. Release the ISA flat-flexible cable (FFC) cover (callout 1), and then remove it (callout 2).

Figure 1-1460 Remove the ISA FFC cover

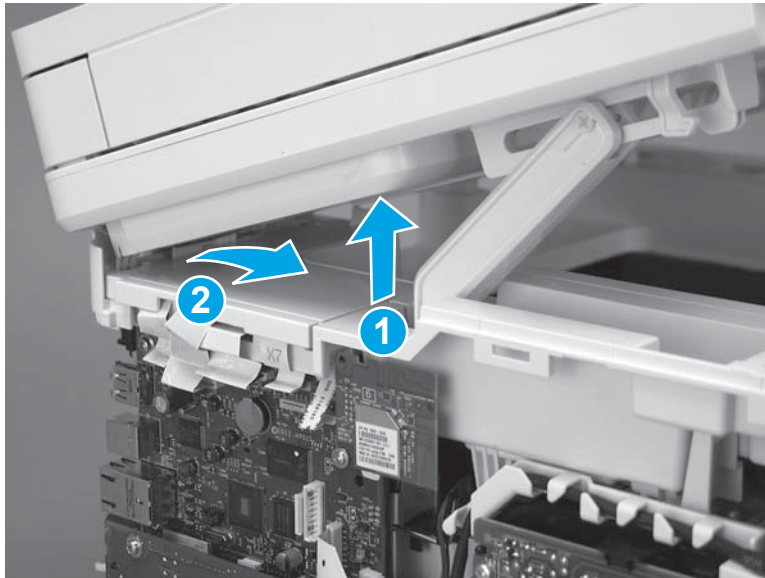

3. Disconnect three FFCs (callout 1), and then remove the ferrite (callout 2) from the holder.

⚠ CAUTION: The ferrite is not captive on the FFC. Do not lose the ferrite while handling the ISA.

Figure 1-1461 Disconnect three FFCs

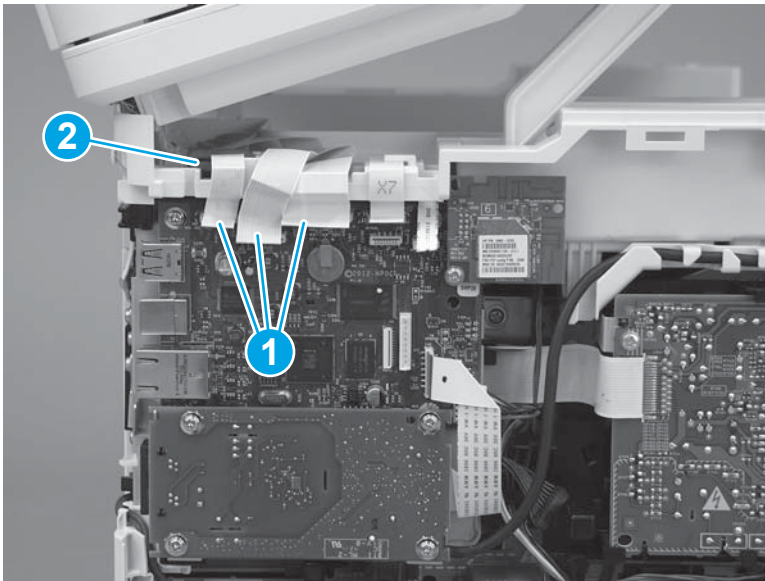

4. Remove one screw (callout 1).

Figure 1-1462 Remove one screw

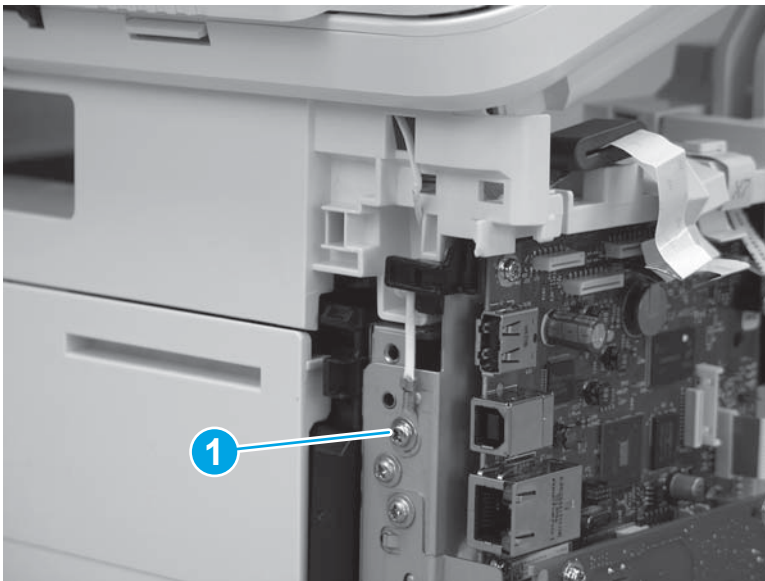

5. Pass the ground wire through the opening in the top cover.

Figure 1-1463 Pass the wire through the opening

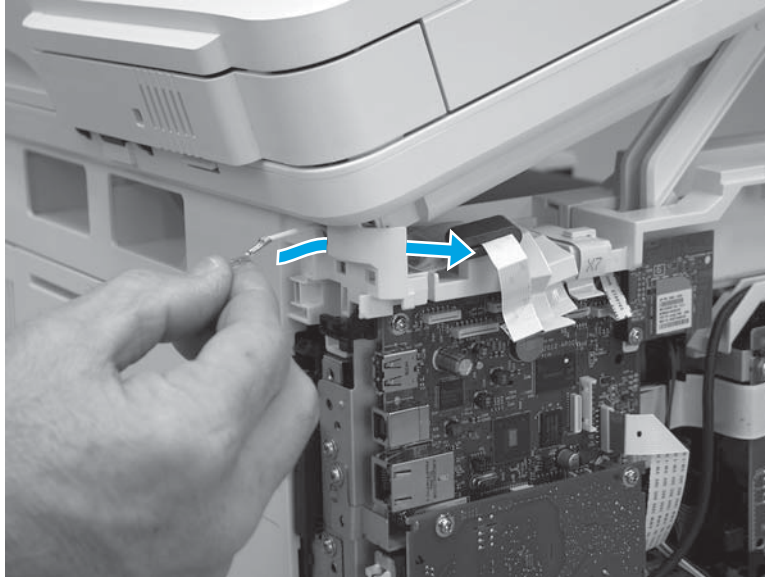

6. Release one tab (callout 1), and then rotate the ISA slider pin (callout 2) towards the front of the printer to release it.

Figure 1-1464 Release one tab and rotate the slider pin

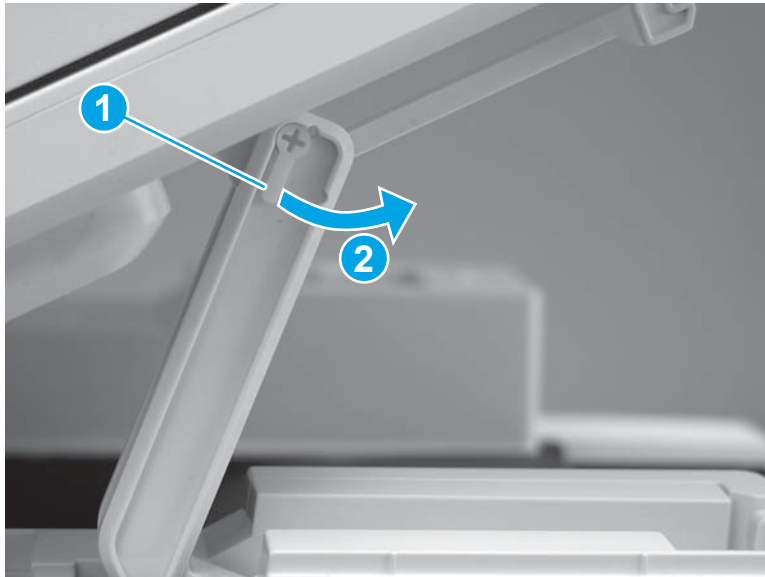

7. Remove the slider pin.

Figure 1-1465 Remove the slider pin

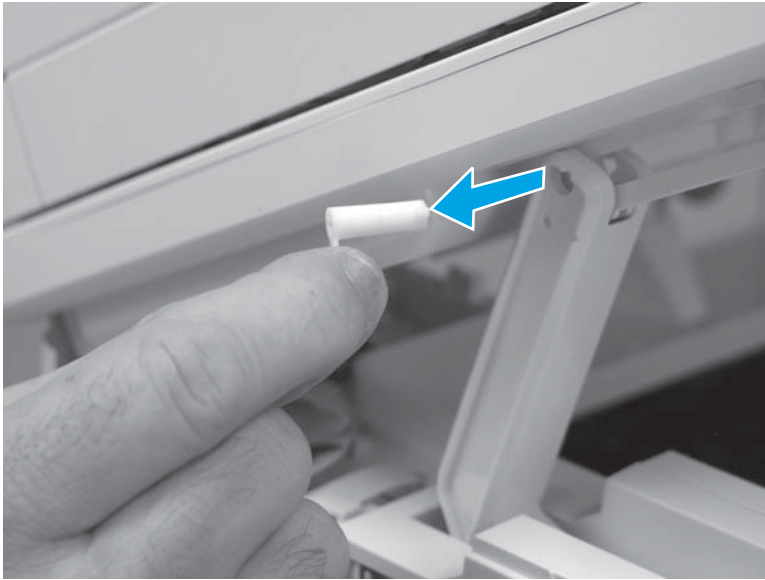

8. Rotate the ISA towards the rear of the printer until it stops.

Figure 1-1466 Rotate the ISA towards the rear of the printer



- Slide the ISA as shown to release it.

Figure 1-1467 Release the ISA

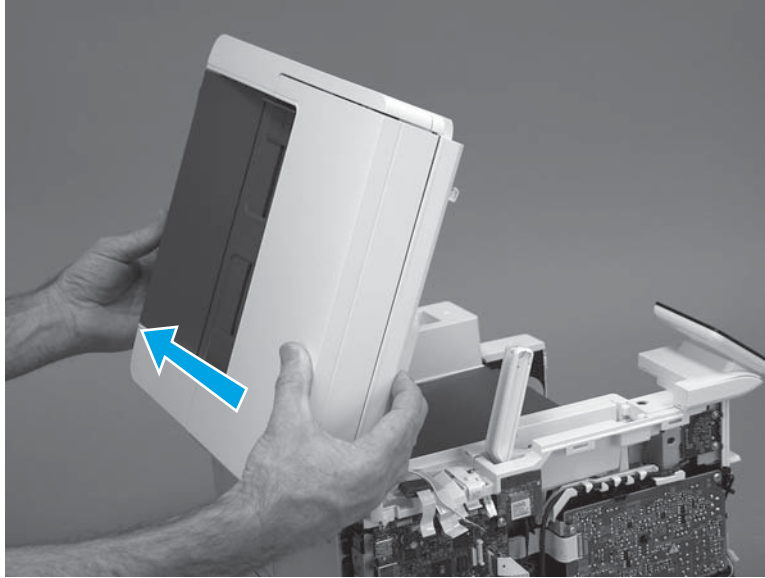

- Remove the ISA.

Figure 1-1468 Remove the ISA

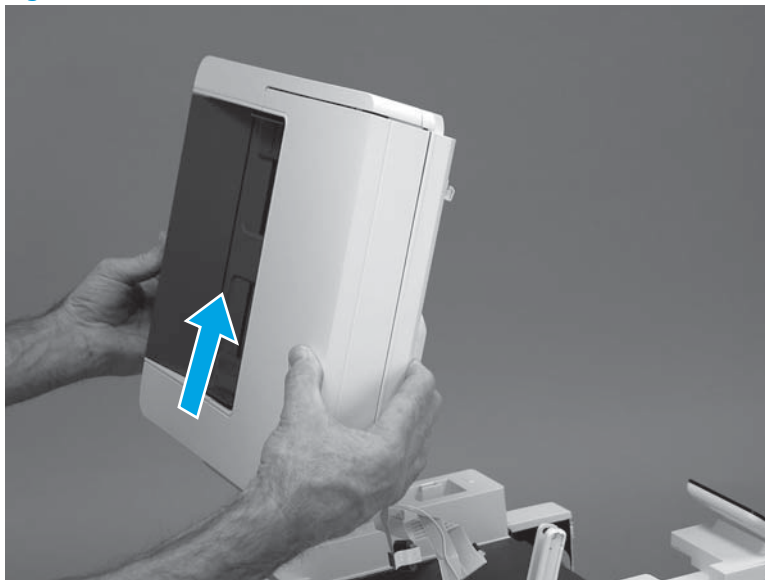

Step 6: Remove the control panel (M427/M246)

 **NOTE:** The step is for the M427/M426 printer. For the M403/M402, skip this step and go to [Step 8: Remove the top cover \(M403/M402\) on page 792](#).

- Disconnect one FFC (callout 1; J114), and then release the FFC from the retainer (callout 2).

Figure 1-1469 Disconnect one connector

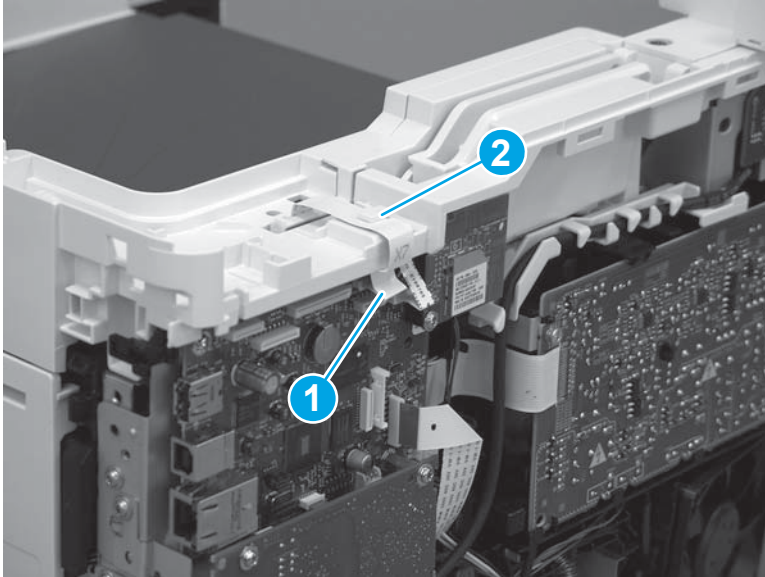

2. Remove one screw (callout 1).

Figure 1-1470 Remove one screw

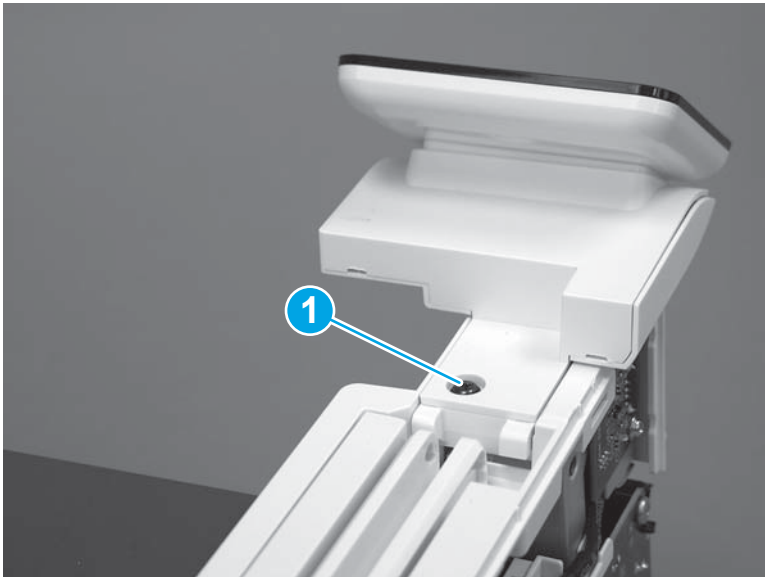

3. Use a small flat-blade screwdriver to release two tabs (callout 1) on the control-panel cable cover.

Figure 1-1471 Release two tabs

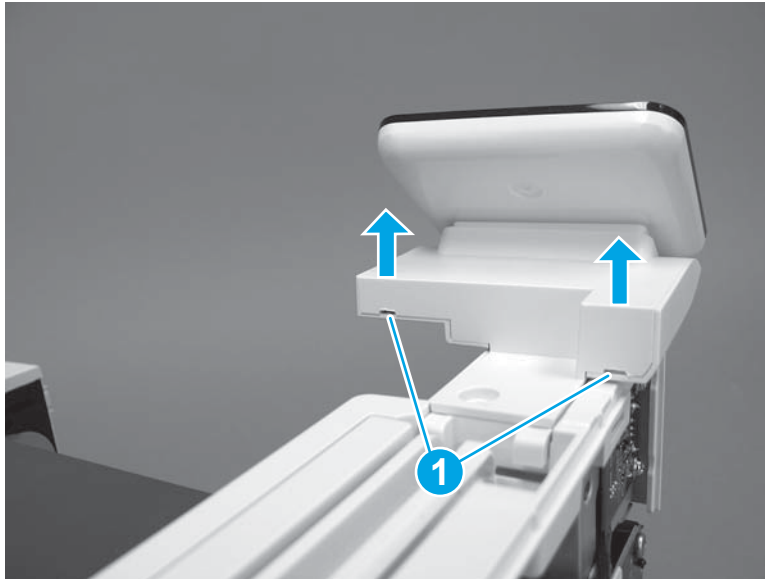

4. Remove the control-panel cable cover.

Figure 1-1472 Remove the cover

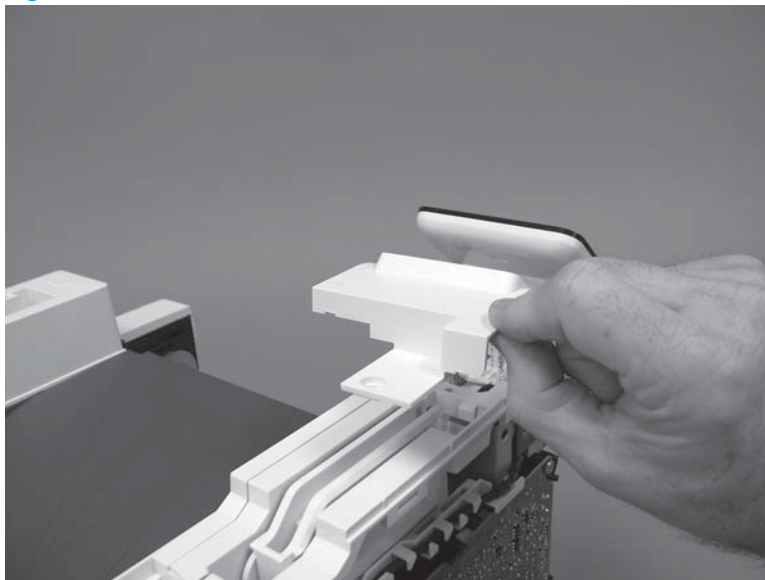

5. Remove one grounding screw (callout 1), and then move the ground cable (callout 2) out of the way.

Figure 1-1473 Remove one screw

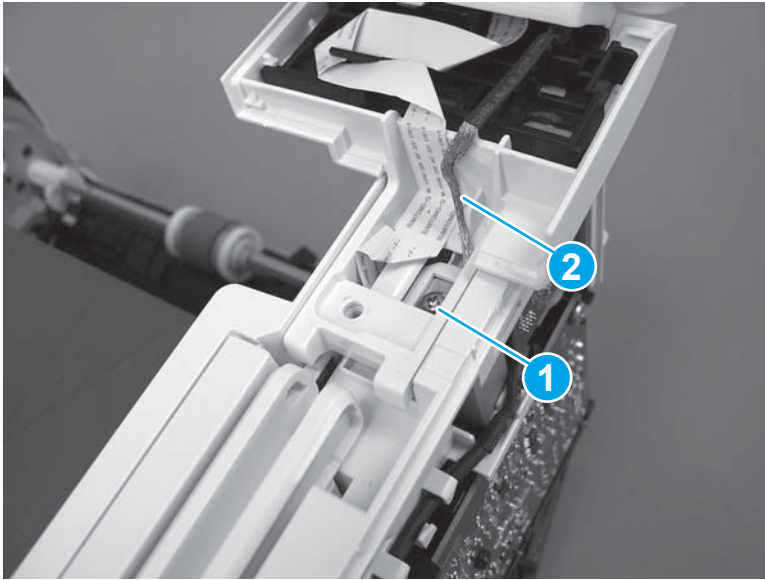

6. Move the FFC out of the way, and then remove two screws (callout 1).

Figure 1-1474 Remove two screws

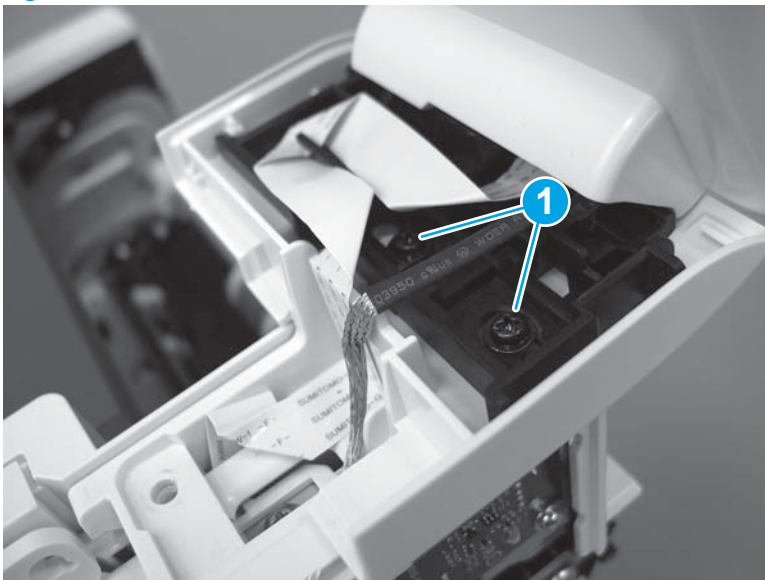

7. Slightly lift up the control-panel assembly to separate it from the top cover.

CAUTION: The control panel assembly is still connected to the printer by the FFC. Do not attempt to completely remove the assembly.

Figure 1-1475 Lift up the control-panel assembly

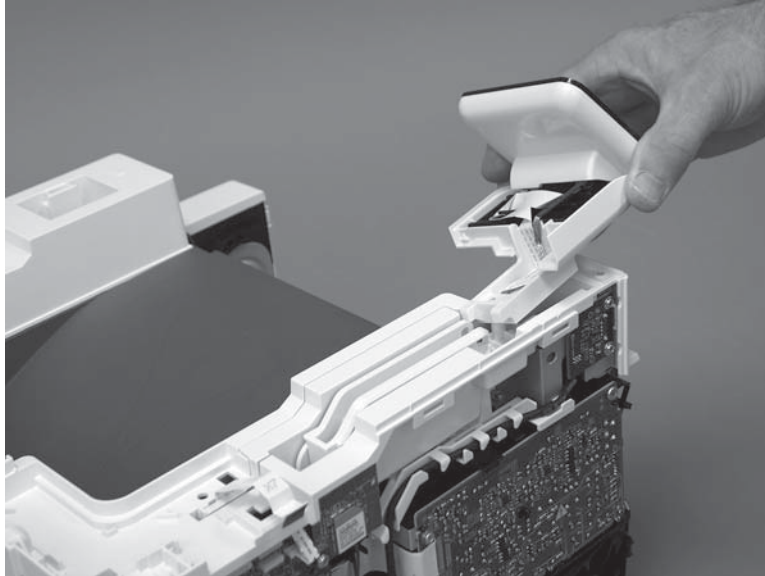

8. Lift up the control-panel FFC cover to remove the control-panel assembly.

Figure 1-1476 Remove the control-panel assembly

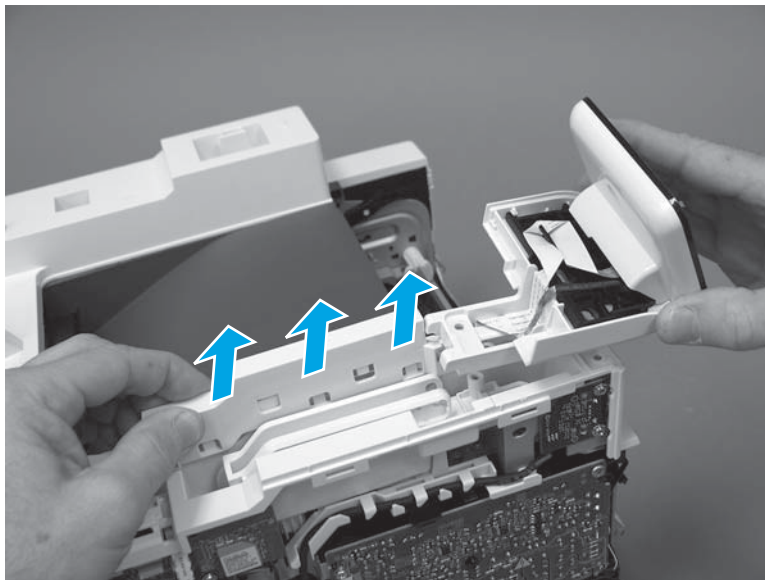

Step 7: Remove the top cover (M427/M426)

NOTE: The step is for the M427/M426 printer. For the M403/M402, skip this step and go to [Step 8: Remove the top cover \(M403/M402\) on page 792](#).

1. Release the USB cable (callout 1) from the cable guide.

Figure 1-1477 Remove the USB cable

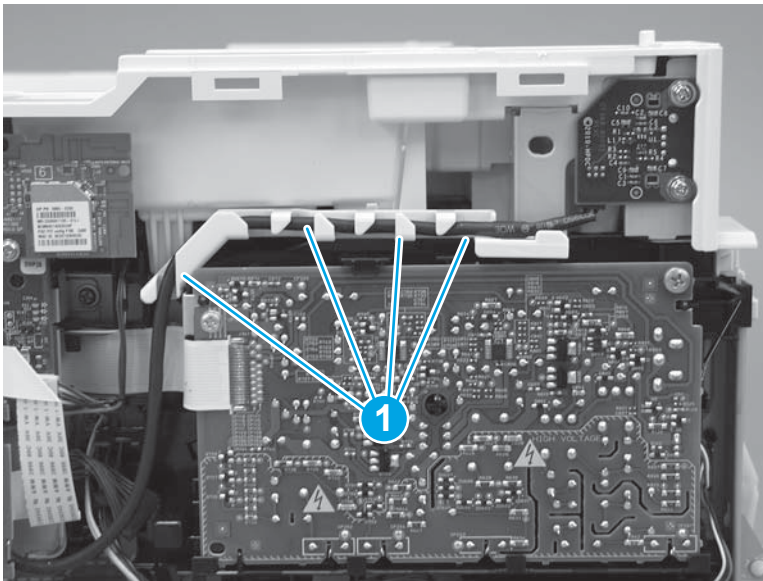

2. Remove five screws (callout 1), release four bosses (callout 2), and then remove the top cover (callout 3).

Figure 1-1478 Remove the cover

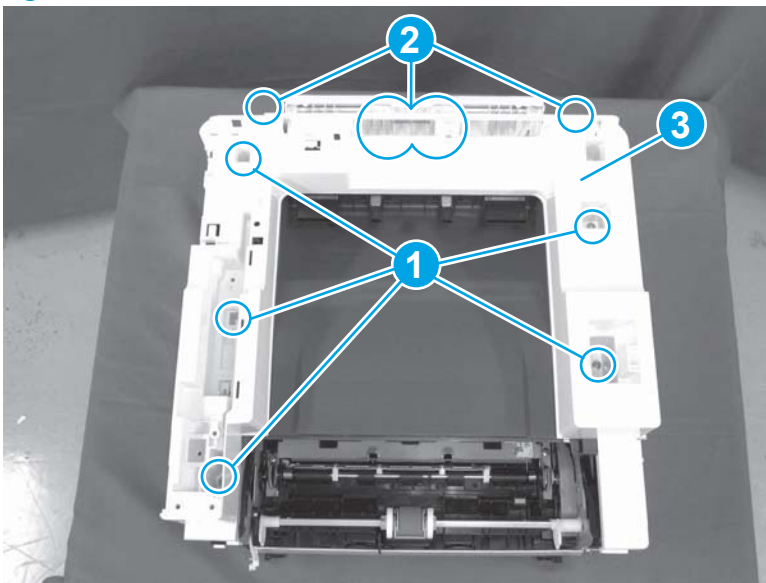

Step 8: Remove the top cover (M403/M402)

 **NOTE:** The step is for the M403/M402 printer. For the M427/M426, skip this step and go to [Step 9: Remove the paper delivery tray \(output bin\) on page 794.](#)

1. Remove one screw (callout 1).

Figure 1-1479 Remove one screw



2. At the right side of the printer, release the one boss (callout 1), and then release one tab (callout 2).

Figure 1-1480 Release one boss and one tab

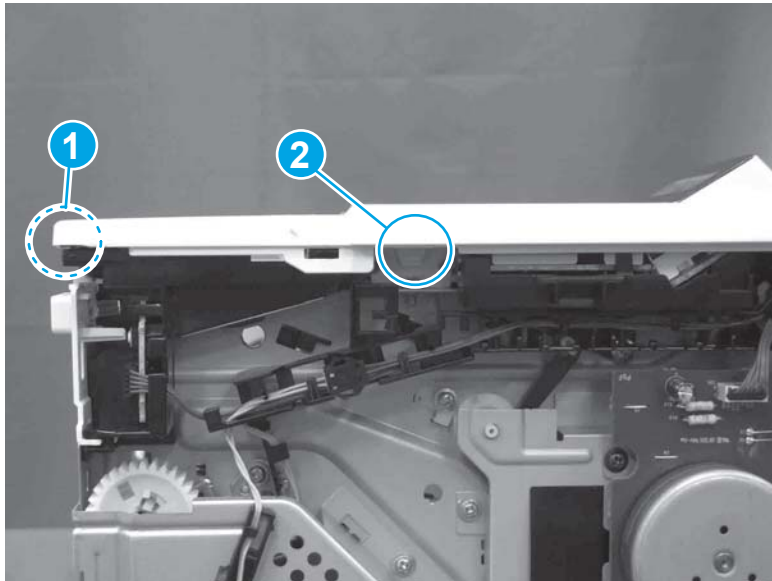

3. Release four tabs (callout 1), release four bosses (callout 2), and then remove the top cover (callout 3).



 **TIP:** Open the rear door to make releasing the bosses (callout 3) easier.

Figure 1-1481 Remove the cover

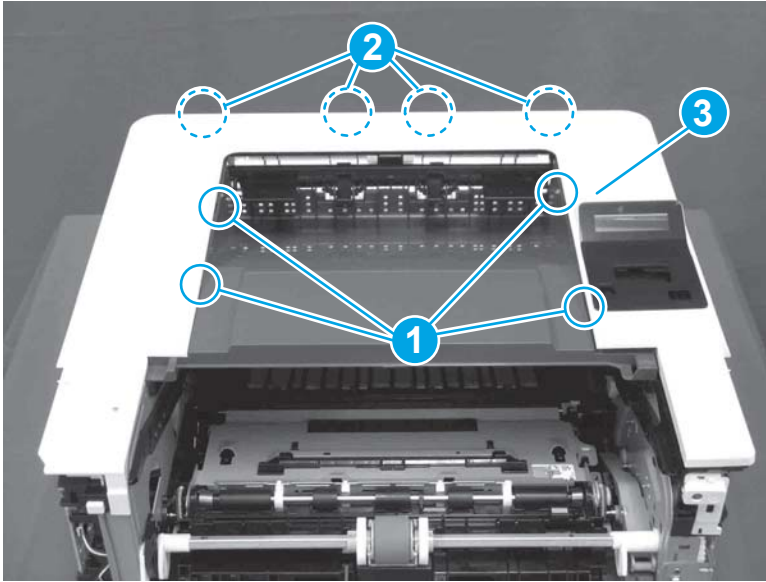

Step 9: Remove the paper delivery tray (output bin)

 **NOTE:** This procedure shows the M403/M402 model, however, the paper delivery tray (output bin) removal is similar for the M427/M426 printer.

- ▲ Release two bosses (callout 1), release two tabs (callout 2), and then remove the paper delivery tray (output bin; callout 3).

Figure 1-1482 Release two tabs

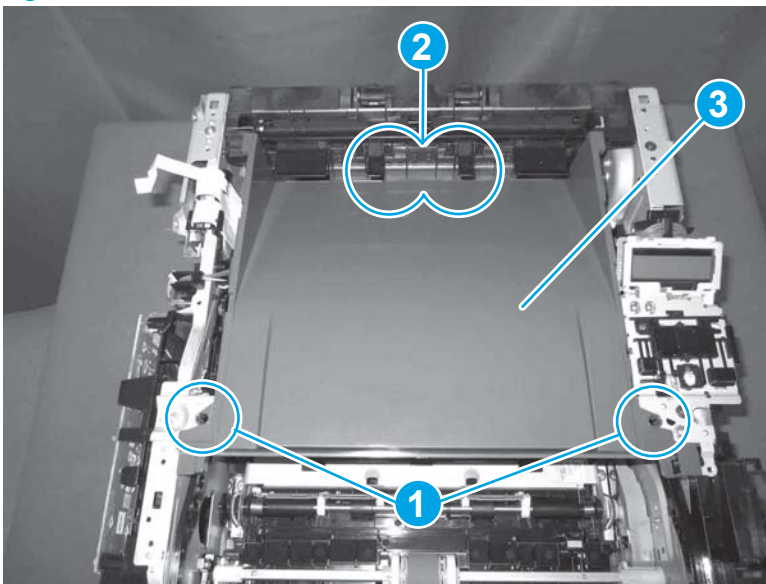

Step 10: Remove the sheet-metal formatter bracket and formatter PCA

 **NOTE:** Disconnect any remaining formatter PCA FFCs or wire-harness connectors.

1. **M427/M426 only:** Remove the guide (callout 1).

Figure 1-1483 Remove the guide

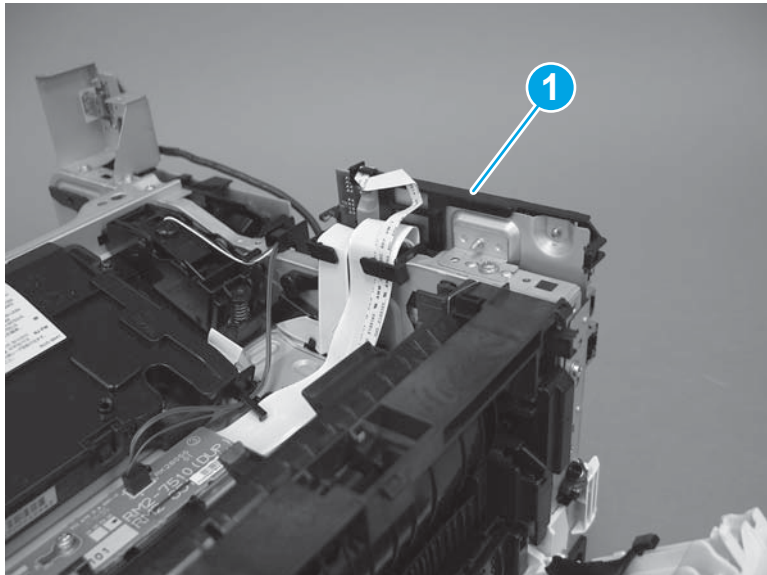

2. Remove two screws (callout 1).

Figure 1-1484 Remove two screws

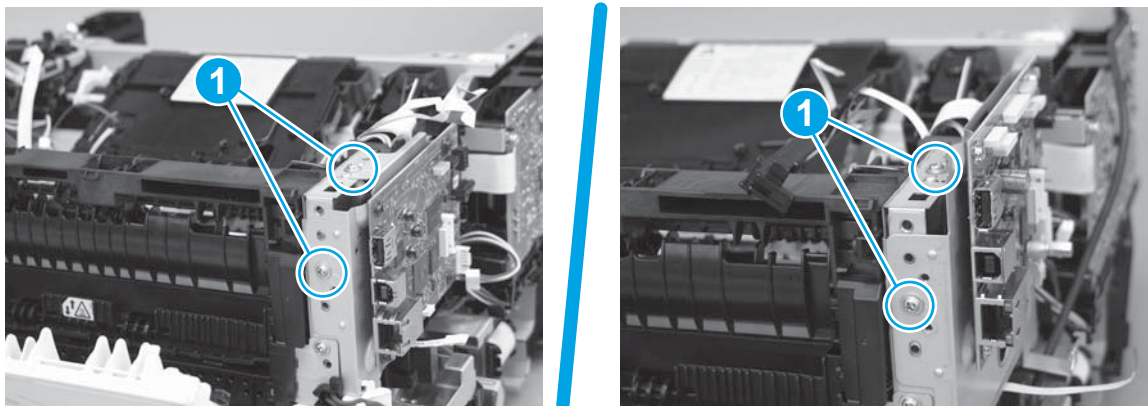

3. Disconnect one connector (callout 1), and then release the wire harness from the guide (callout 2).

Figure 1-1485 Disconnect one connector

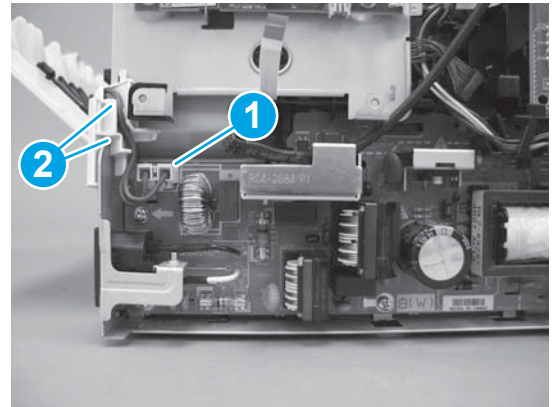
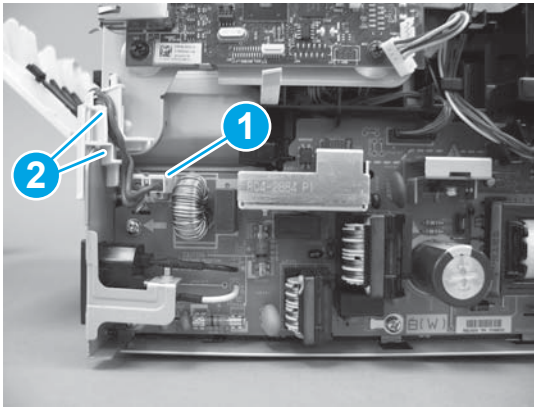

4. Remove the guide (callout 1).

Figure 1-1486 Remove the guide

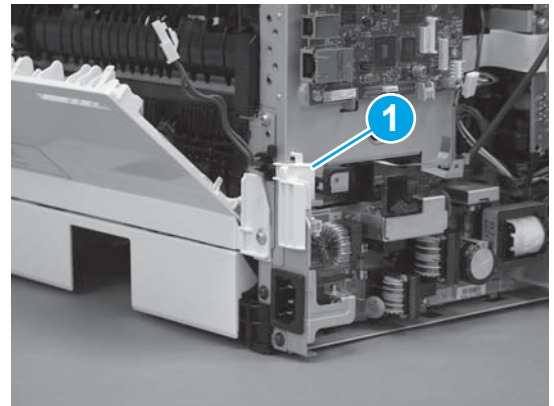
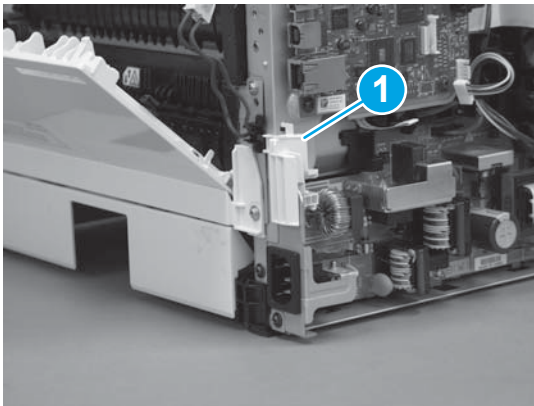

5. Remove three screws (callout 1).

Figure 1-1487 Remove three screws

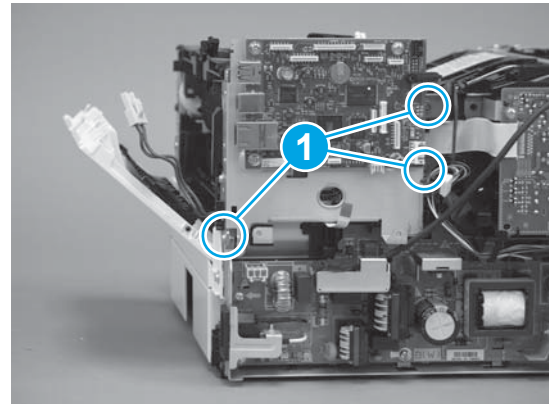
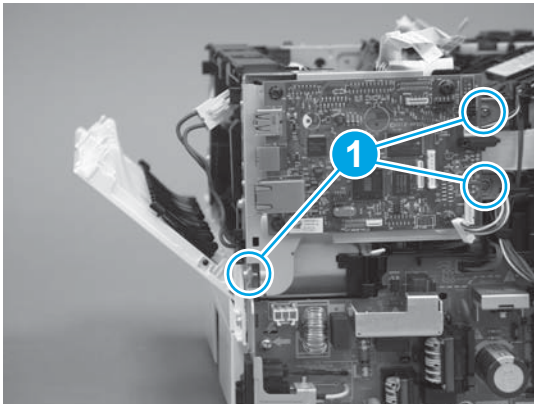

6. Remove the sheet-metal bracket and formatter PCA.

Figure 1-1488 Remove the bracket

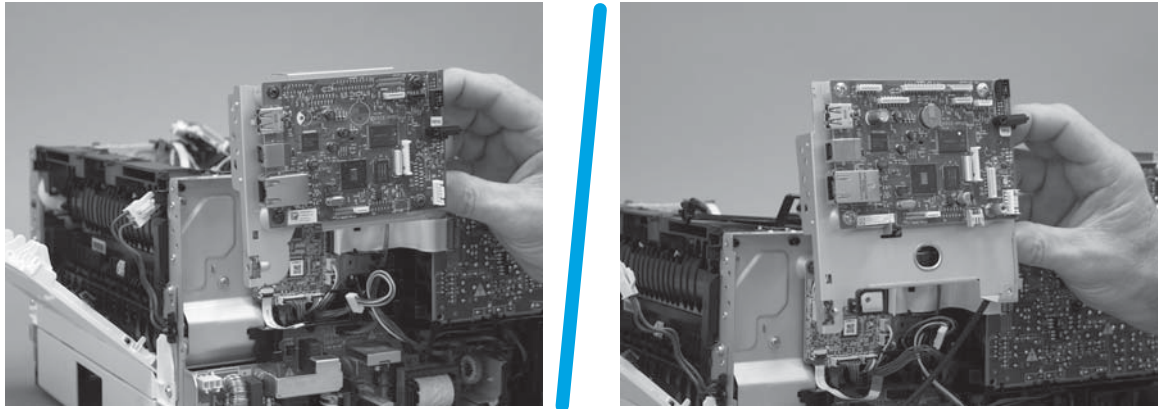

Step 11: Remove the tag-cable assembly (toner-cartridge memory)

1. Disconnect one connector (callout 1), and then release the wire harness from the guide (callout 2).

Figure 1-1489 Disconnect one connector

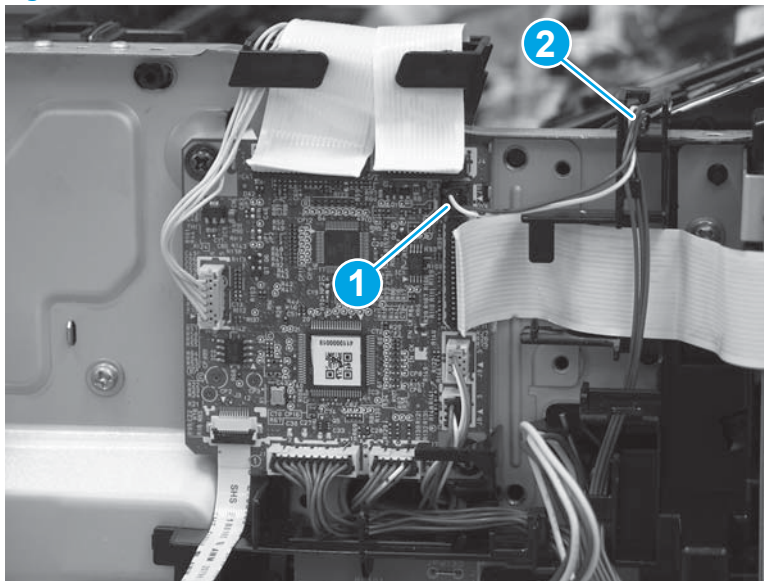

2. Remove one screw (callout 1).

Figure 1-1490 Remove one screw

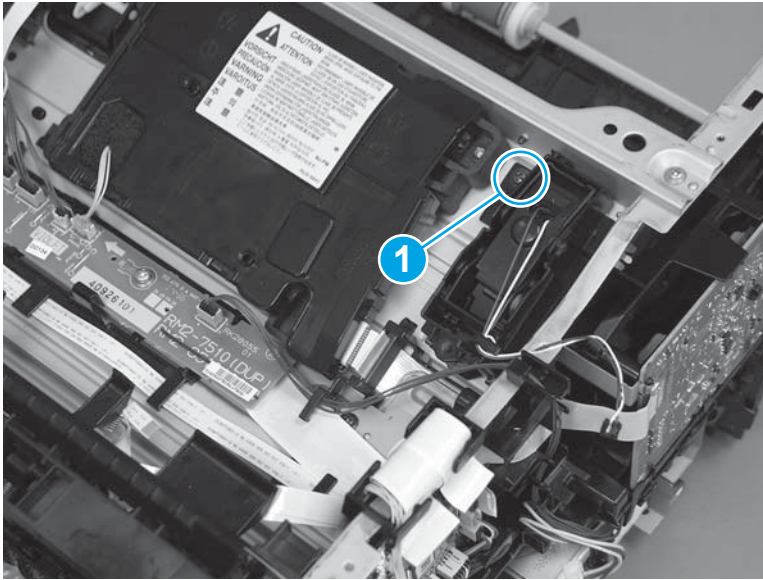

3. Remove the tag-cable assembly.

Figure 1-1491 Remove the tag-cable assembly

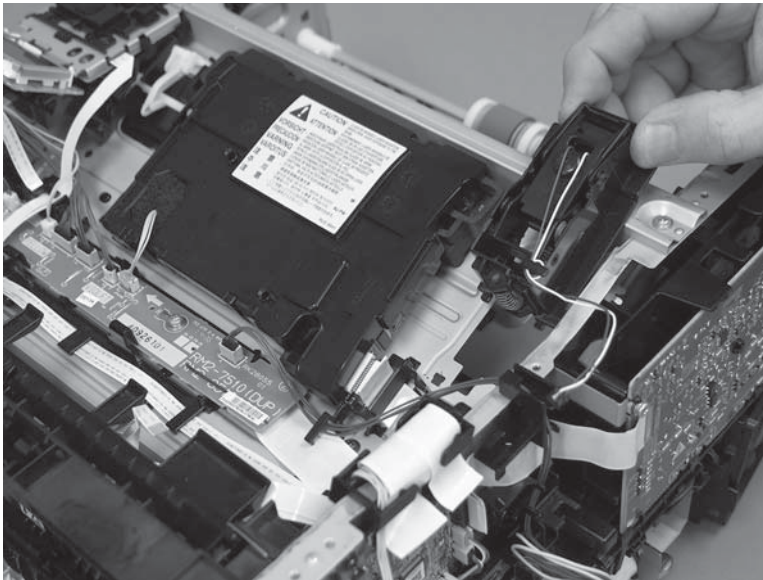

Step 12: Unpack the replacement assembly

Unpack the replacement part from the packaging.

<http://www8.hp.com/us/en/hp-information/environment/product-recycling.html>



NOTE: HP recommends responsible disposal of the defective part.

Figure 1-1492 Recycle and unpack

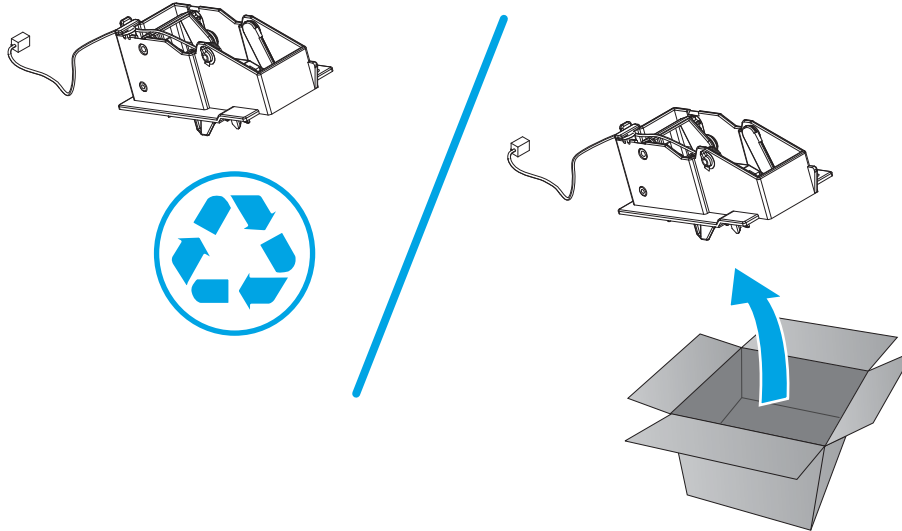

Step 13: Install the tag-cable assembly (toner-cartridge memory)

1. Position the assembly on the printer.

 **IMPORTANT:** Make sure that the assembly is flat against the chassis. If the assembly is not correctly installed, it might not make proper contact with the toner cartridge.

Figure 1-1493 Install the assembly



2. Install one screw (callout 1).

Figure 1-1494 Install one screw

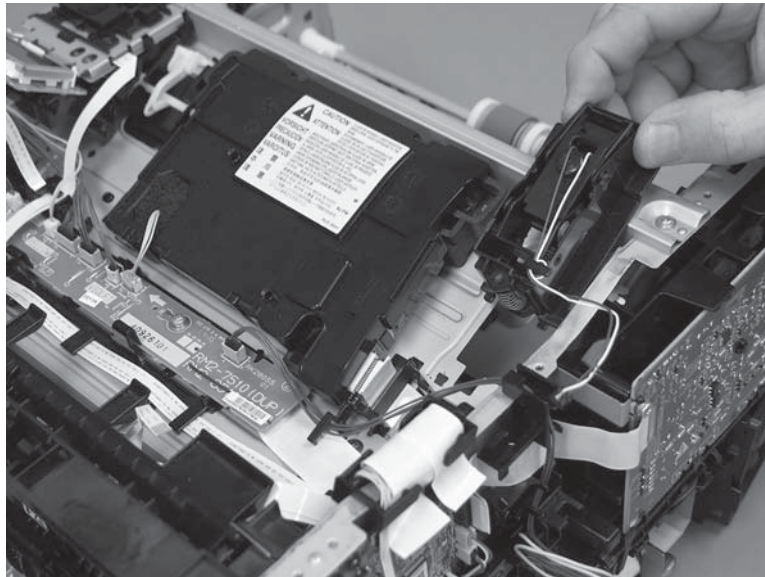
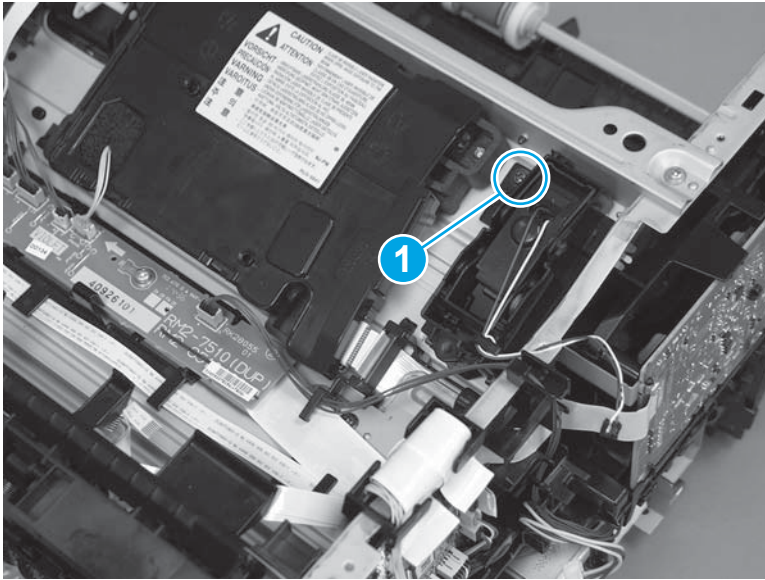

3. Install the wire harness in the guide (callout 1), and then connect one connector (callout 2).

Figure 1-1495 Connect one connector

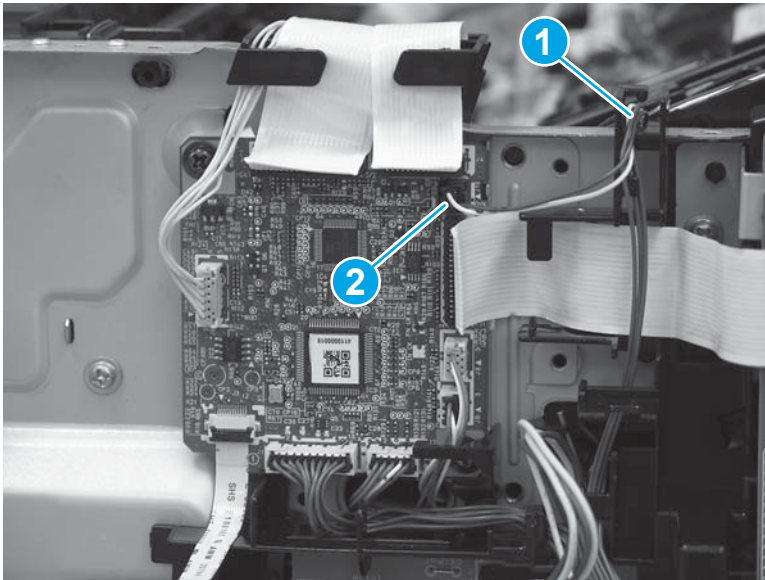

Step 14: Install the sheet-metal formatter bracket and formatter PCA

 **NOTE:** Do not forget to connect any formatter PCA FFCs or wire-harness connectors that were disconnected when the bracket was removed.

1. Position the sheet-metal bracket and formatter PCA on the printer.

Figure 1-1496 Install the bracket

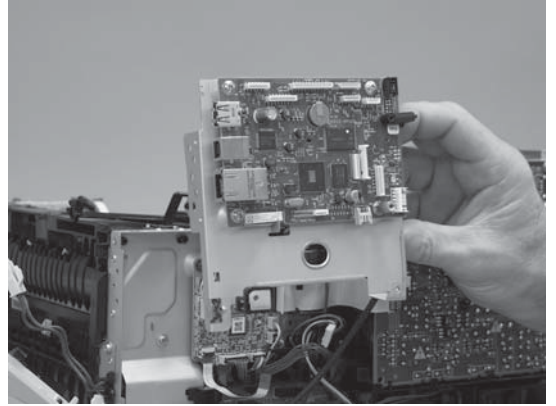
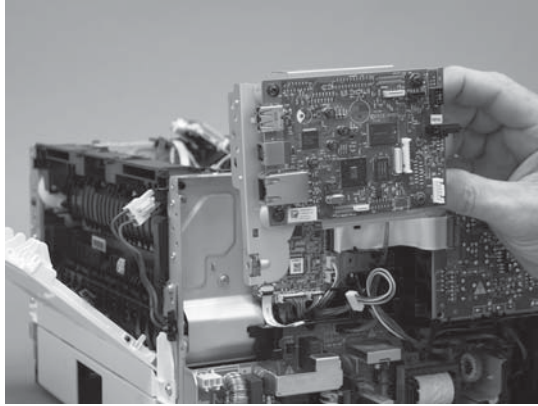

2. Install three screws (callout 1).

Figure 1-1497 Install three screws

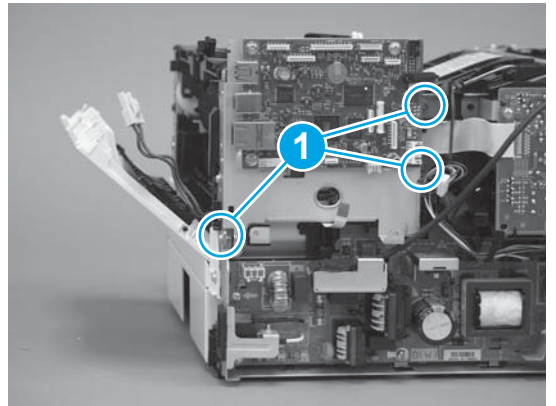
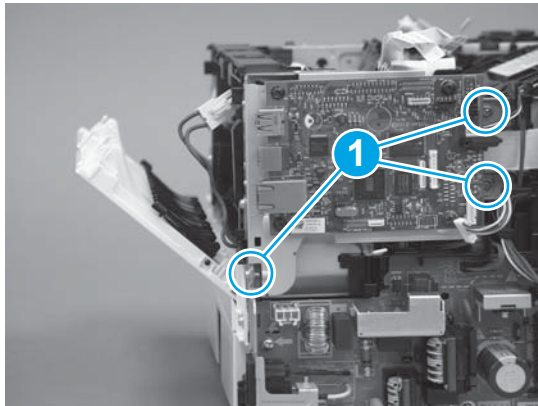

3. Install the guide (callout 1).

Figure 1-1498 Install the guide

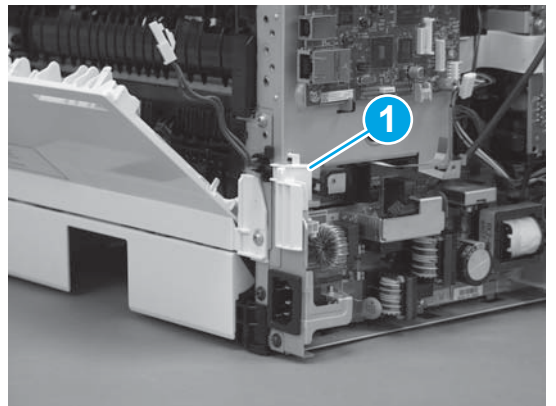
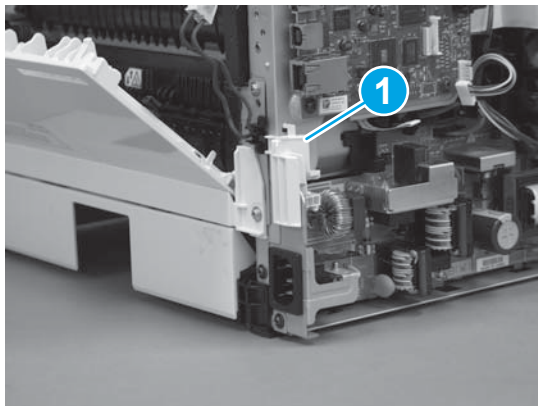

4. Connect one connector (callout 1), and then install the wire harness in the guide (callout 2).

Figure 1-1499 Connect one connector

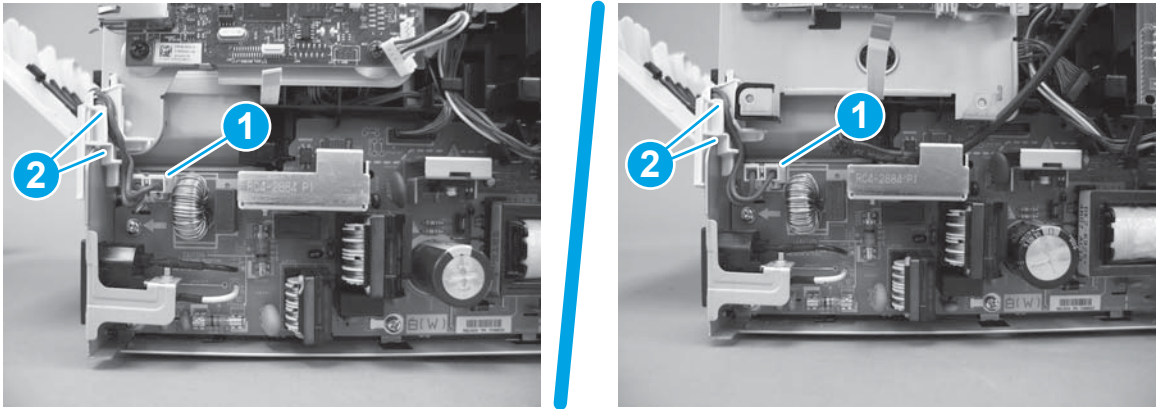

5. Install two screws (callout 1).

Figure 1-1500 Install two screws

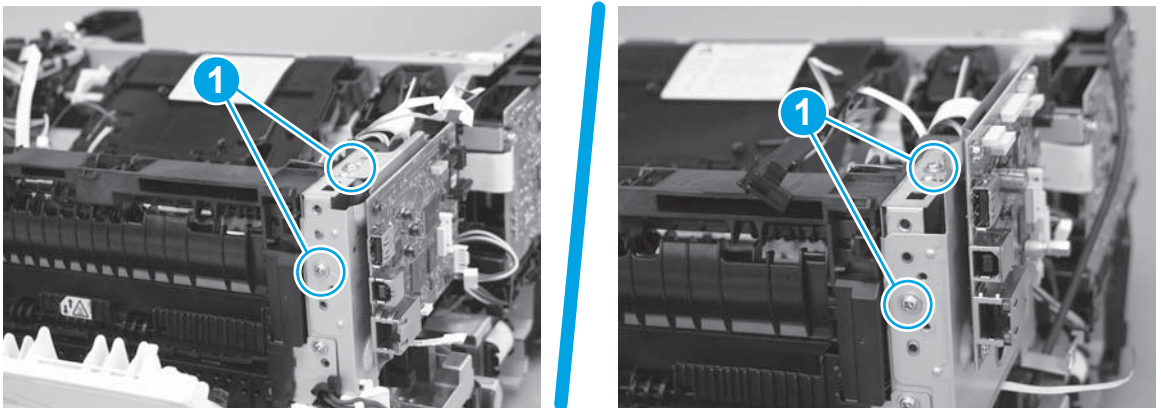

6. **M427/M426 only:** Install the guide (callout 1).

Figure 1-1501 Install the guide

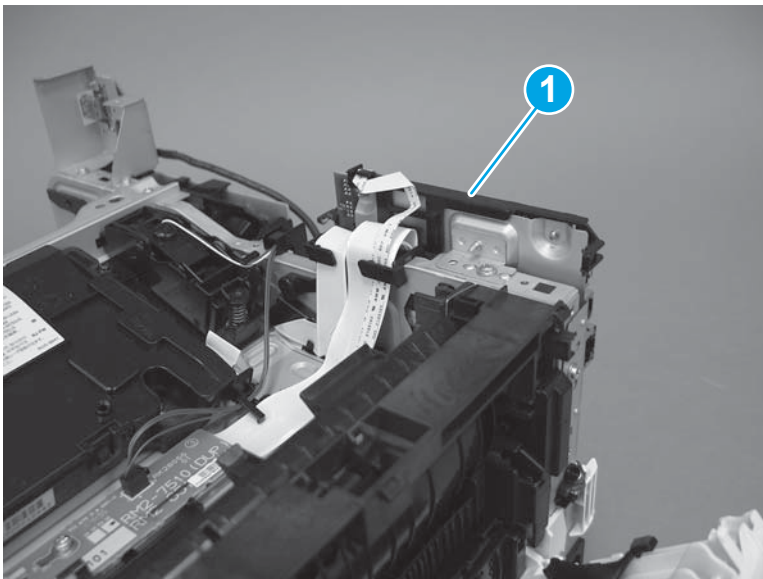

Step 15: Install the paper delivery tray (output bin)

 **NOTE:** This procedure shows the M403/M402 model, however, the paper delivery tray (output bin) removal is similar for the M427/M426 printer.

- ▲ Position the remove the paper delivery tray (output bin; callout 1) on the printer, engage two tabs (callout 2), and then engage two bosses (callout 3).

Figure 1-1502 Engage two tabs

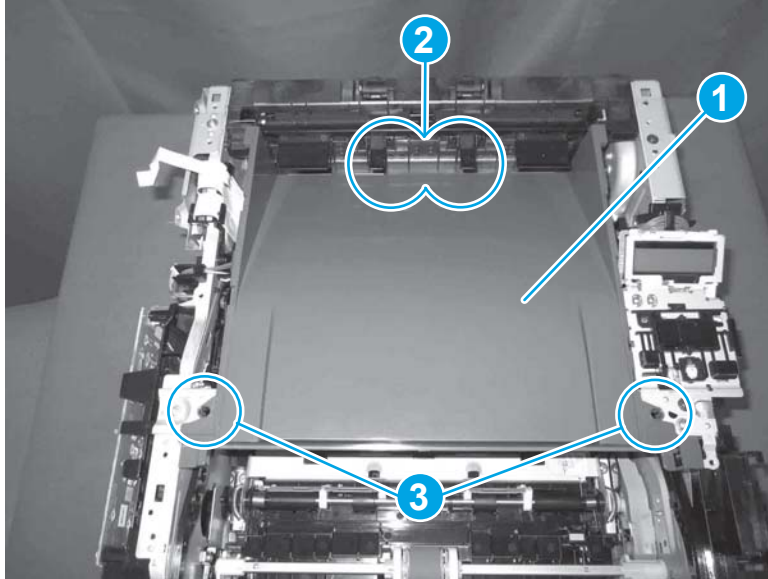

Step 16: Install the top cover (M403/M402)

 **NOTE:** The step is for the M403/M402 printer. For the M427/M426, skip this step and go to [Step 17: Install the top cover \(M427/M426\) on page 805](#).

1. Position the rear edge of the cover on the printer.

Figure 1-1503 Install the cover

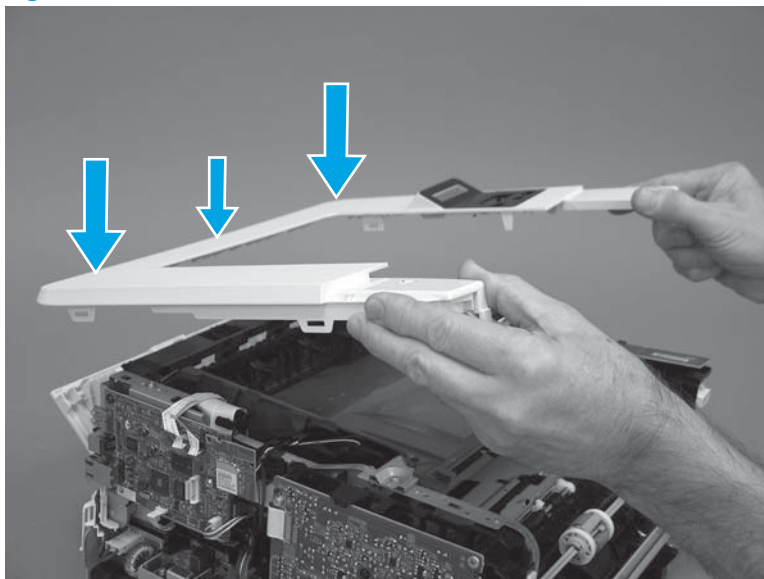

- Engage four bosses (callout 1), rotate the front of the cover down (callout 2) and onto from the printer, and then engage four tabs (callout 3).

Figure 1-1504 Engage four bosses and tabs

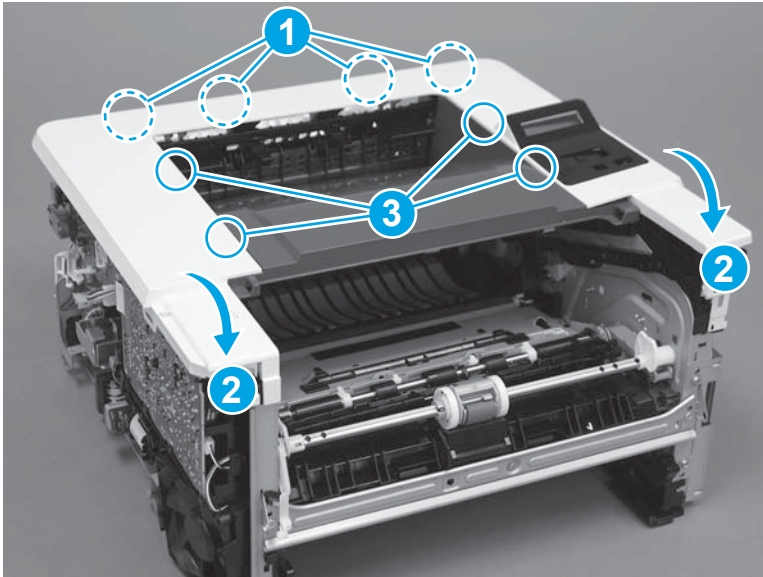

- At the right side of the printer, engage the one boss and one tab (callout 1).

Figure 1-1505 Engage one boss and one tab

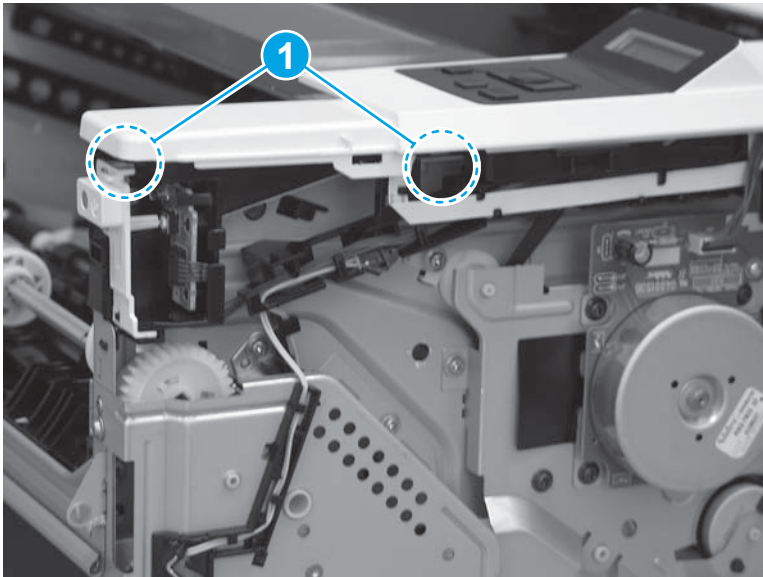

4. Install one screw (callout 1).

Figure 1-1506 Install one screw

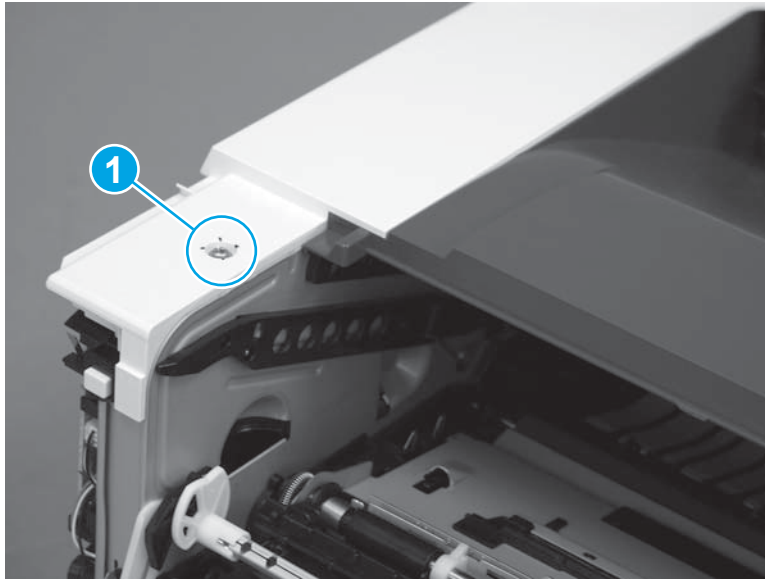

Step 17: Install the top cover (M427/M426)

 **NOTE:** The step is for the M427/M426 printer. For the M403/M402, skip this step and go to [Step 20: Install the right cover on page 816](#).

1. Position the rear edge of the top cover on the printer.

Figure 1-1507 Install the cover

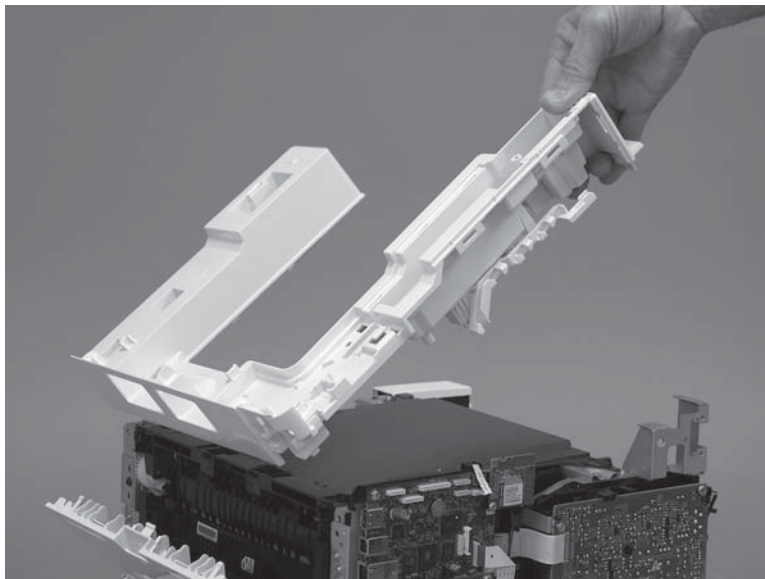

2. Engage four bosses (callout 1).

Figure 1-1508 Engage four bosses

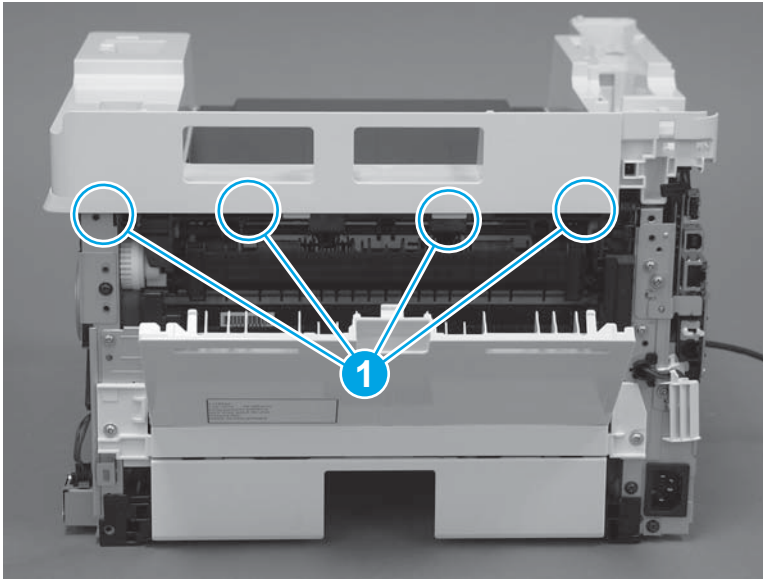

3. Rotate the front edge of the cover down.

Figure 1-1509 Rotate the front edge of the cover down

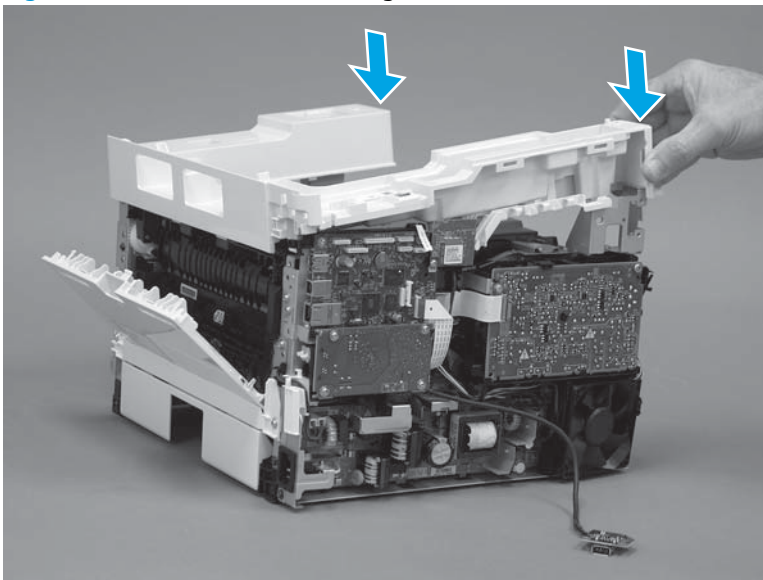

4. Install the USB cable (callout 1) in the guide.

Figure 1-1510 Install the USB PCA

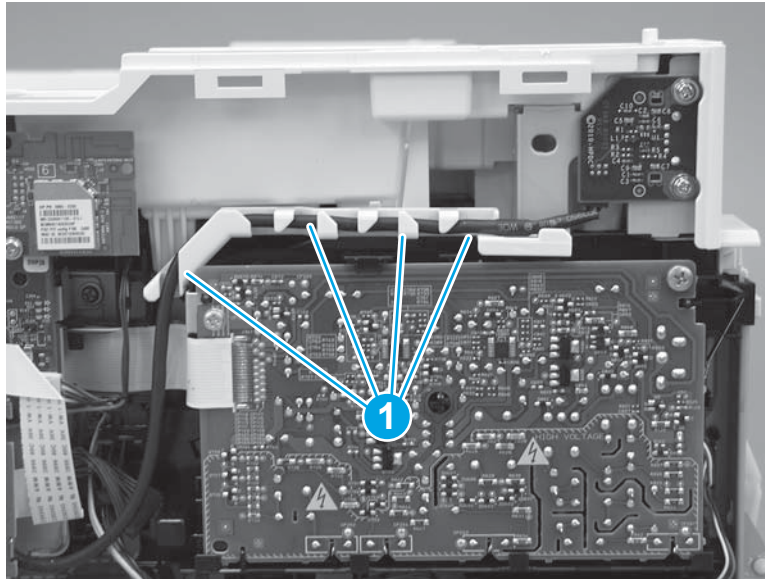

5. Install five screws (callout 1).

Figure 1-1511 Install five screws

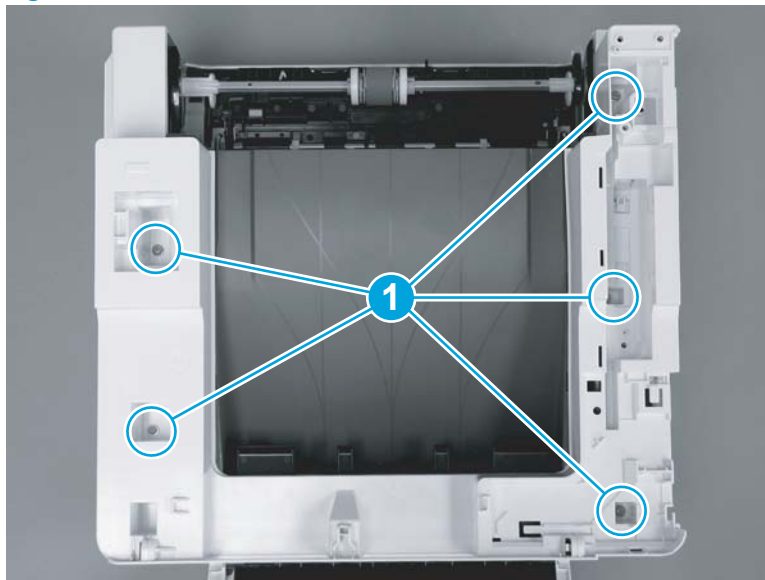

Step 18: Install the control panel (M427/M246)

 **NOTE:** The step is for the M427/M426 printer. For the M403/M402, skip this step and go to [Step 20: Install the right cover on page 816](#).

1. Slide the control-panel FFC cover into the slot in the top cover (next to the document feeder support arm) to install it.

Figure 1-1512 Install the control-panel FFC cover

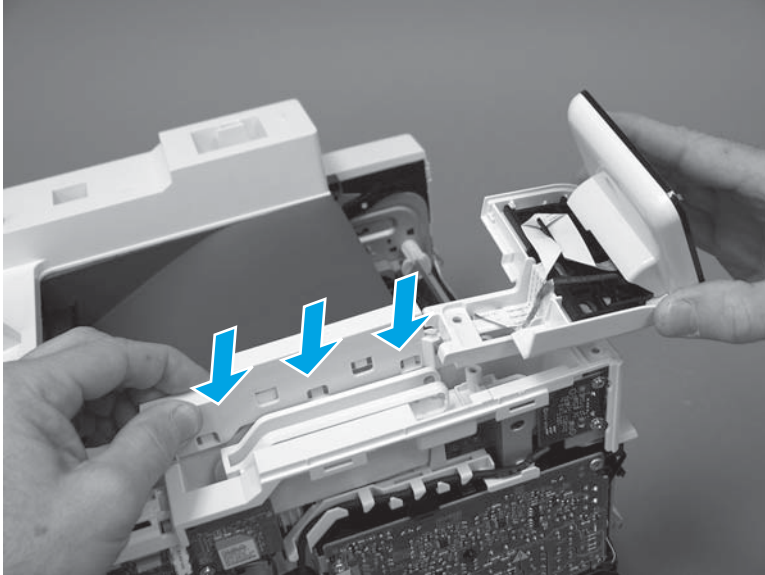

2. Install the control-panel assembly on the top cover.

Figure 1-1513 Install the control-panel assembly

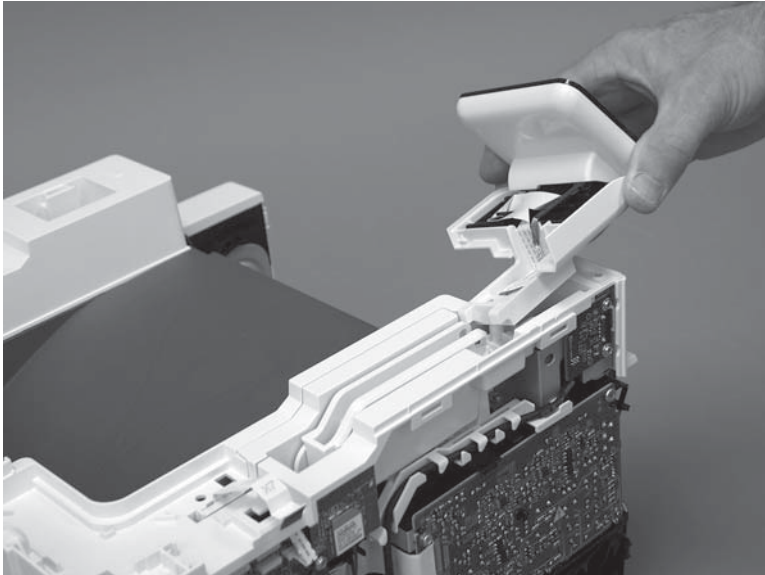

3. Move the FFC out of the way, and then install two screws (callout 1).

Figure 1-1514 Install two screws

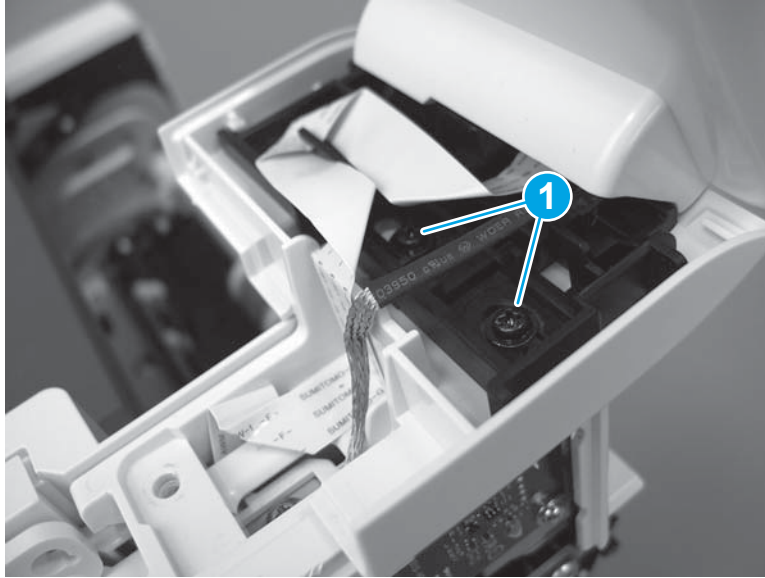

4. Install one grounding screw (callout 1), and then make sure that the ground cable (callout 2) is properly routed.

Figure 1-1515 Remove one screw

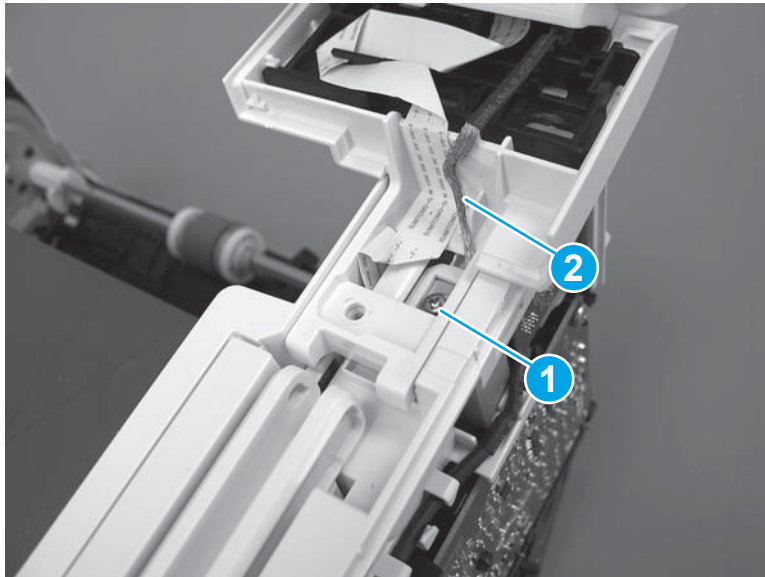

5. Install the control-panel cable cover.

Figure 1-1516 Install the cover

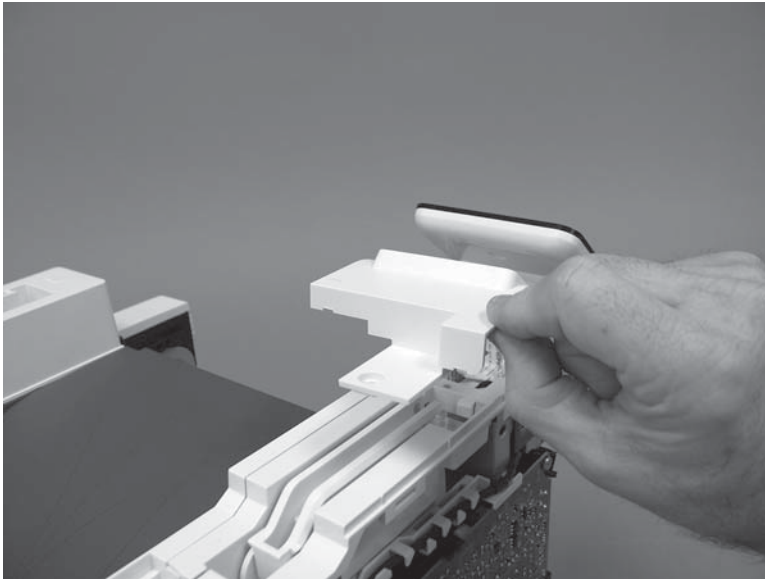

6. Make sure that the two tabs (callout 1) on the cover snap into place.

Figure 1-1517 Engage two tabs

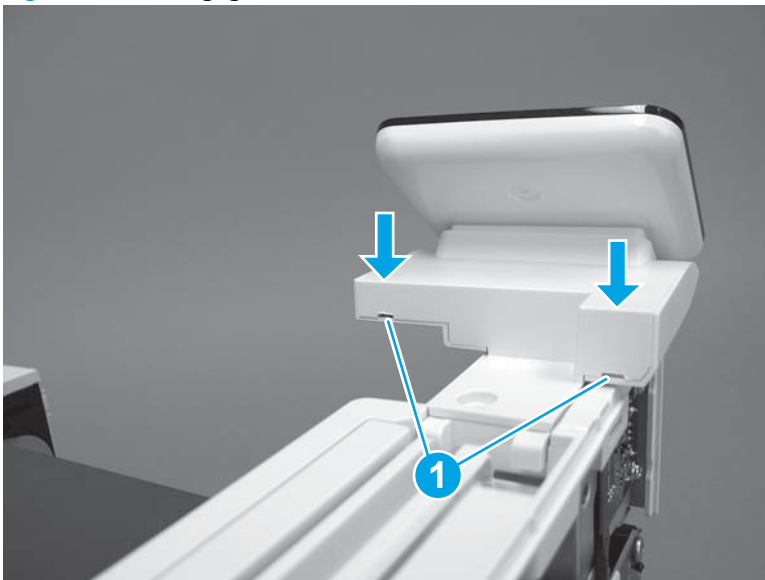

7. Install one screw (callout 1).

Figure 1-1518 Install one screw

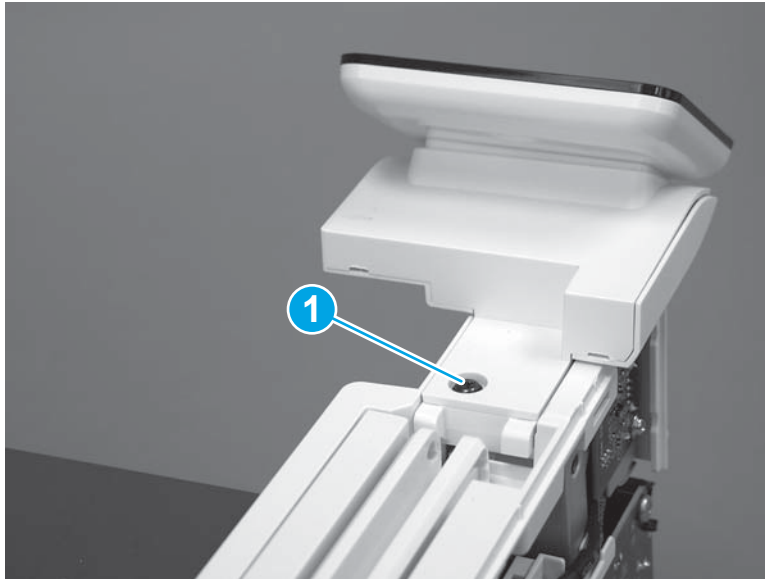

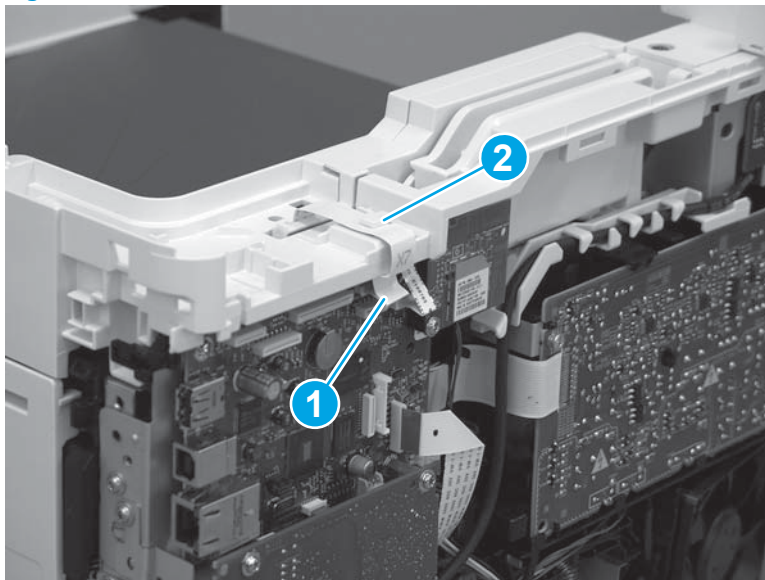

8. Install the FFC in the retainer (callout 1), and then connect one FFC (callout 1; J114).

Figure 1-1519 Connect one connector



Step 19: Install the integrated scanner assembly (M427/M246)

 **NOTE:** The step is for the M427/M426 printer. For the M403/M402, skip this step and go to [Step 20: Install the right cover on page 816](#).

 **NOTE:** M427/M426 models only. The integrated scanner assembly (ISA) includes the sub-scanner assembly (SSA) and the automatic document feeder (ADF).

1. Position the ISA on the printer.

Figure 1-1520 Position the ISA on the printer

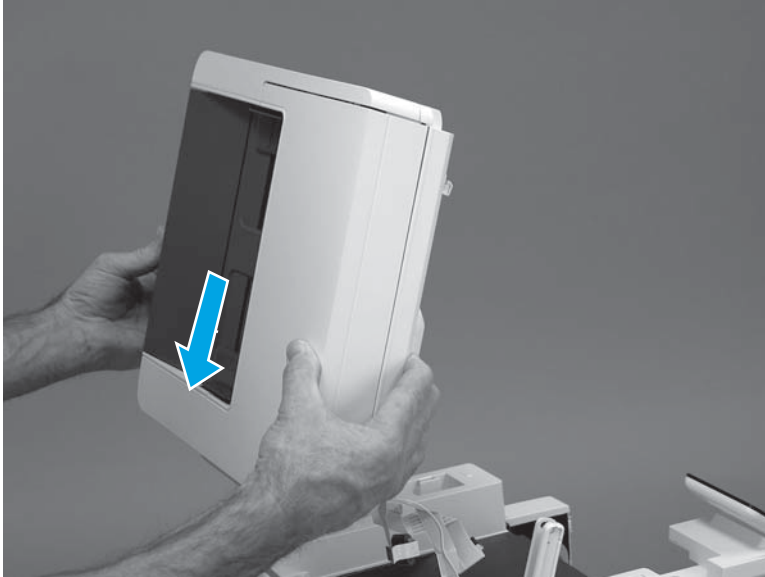

2. Engage the hinge pins on the ISA with the holders in the top cover (callouts 1/2), and then slide the ISA as shown to engage them

Figure 1-1521 Engage the hinge pins with the holders

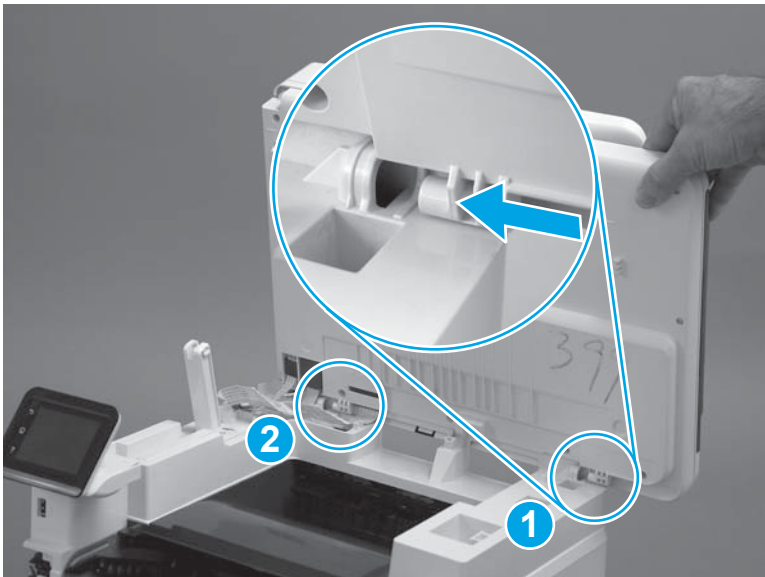

3. Rotate the ISA towards the front of the printer until it rests on the ISA lift assembly (callout 1).

Figure 1-1522 Rotate the ISA towards the front of the printer

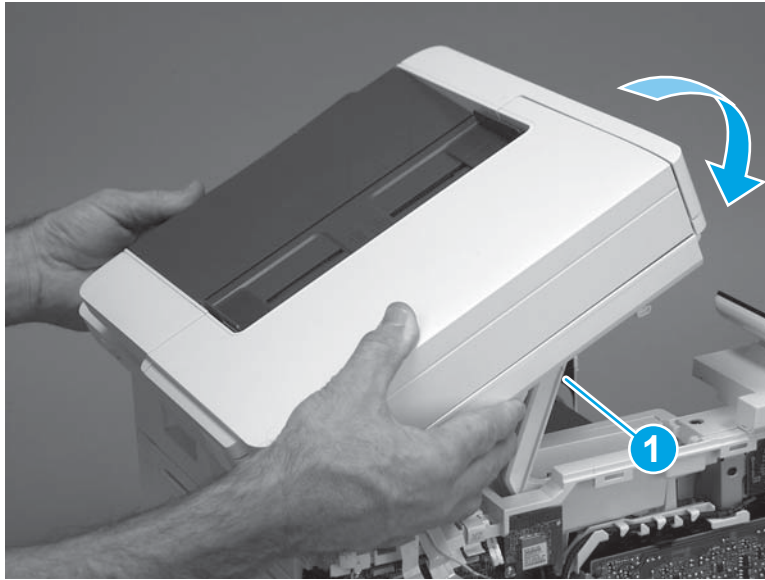

4. Pass the ground wire through the opening in the top cover.

Figure 1-1523 Pass the wire through the opening

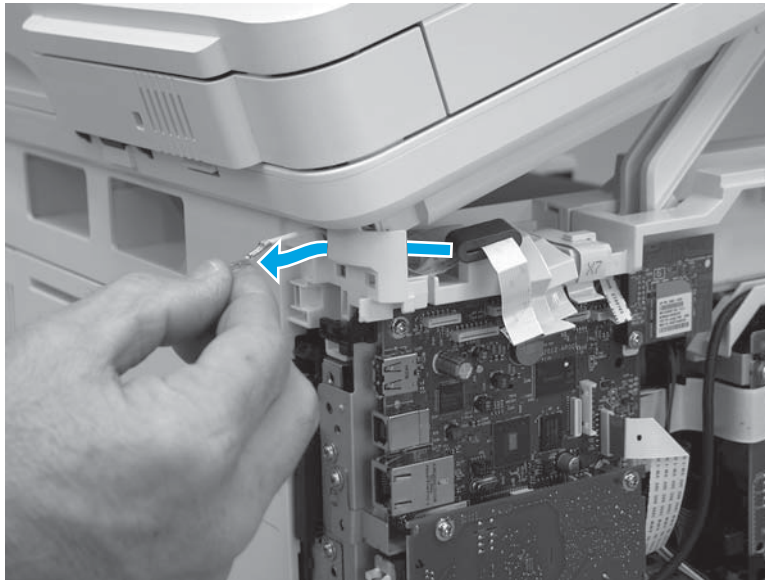

5. Install one screw (callout 1).

Figure 1-1524 Install one screw

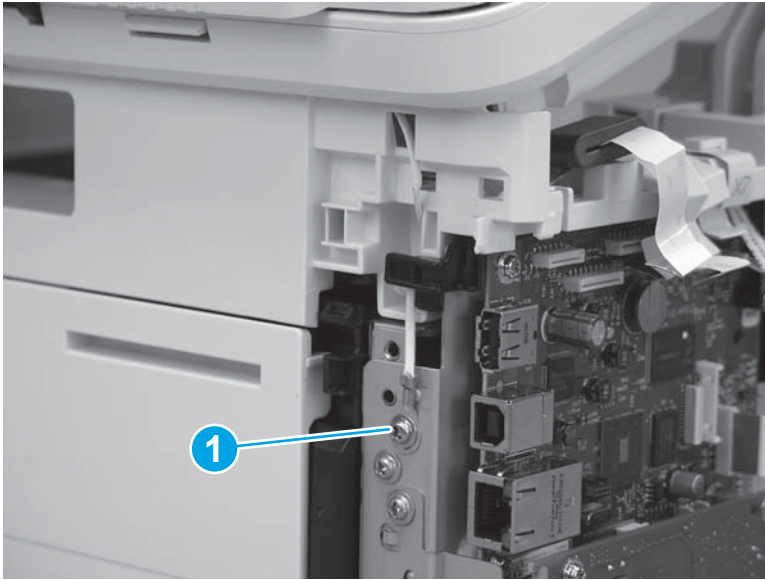

6. Install the ISA lift assembly slider pin.

 **Reinstallation tip:** Align the keyed portion of the locking pin with the slot and hole in the support arm.

Figure 1-1525 Install the slider pin



7. Rotate the slider pin (callout 1) towards the rear of the printer until the tab (callout 2) snap into place.

Figure 1-1526 Secure the slider pin

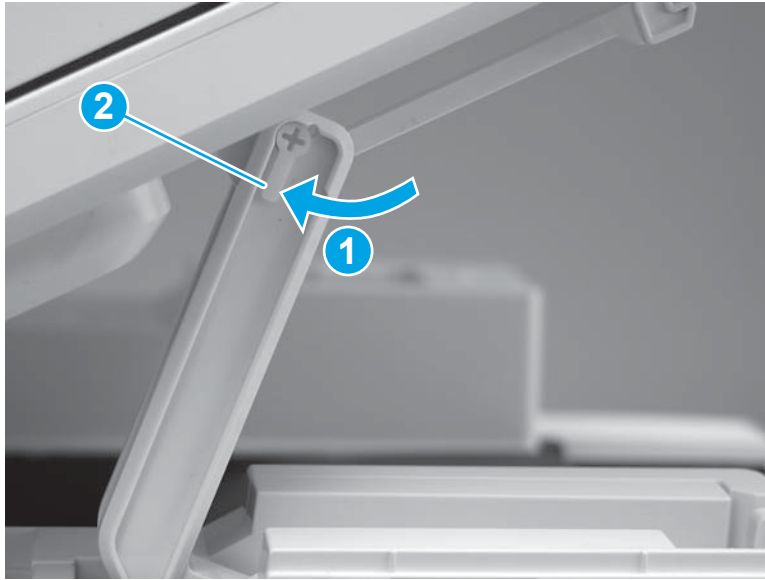

8. Install the ferrite (callout 1) in the holder, and then connect three FFCs (callout 2).

Figure 1-1527 Connect three FFCs

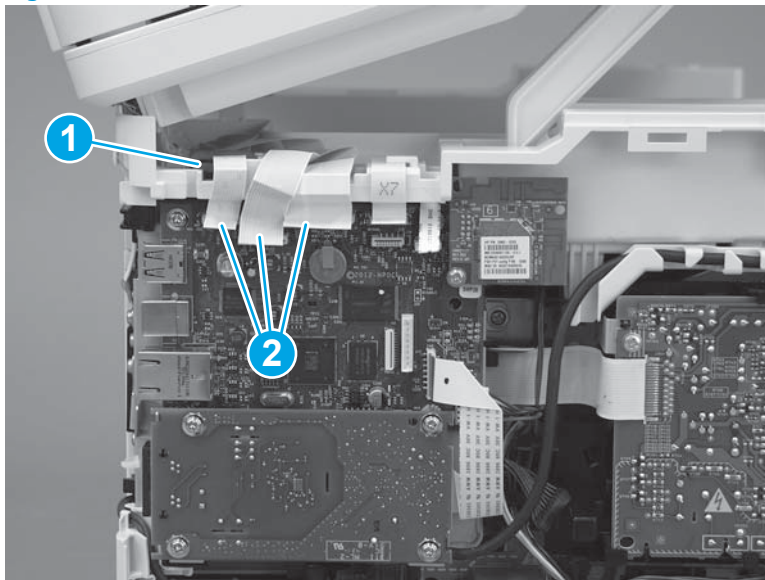

9. Position the rear edge of the ISA flat-flexible cable (FFC) cover on the printer (callout 1) , and then rotate it down (callout 2) until it snaps into place.

Figure 1-1528 Install the ISA FFC cover

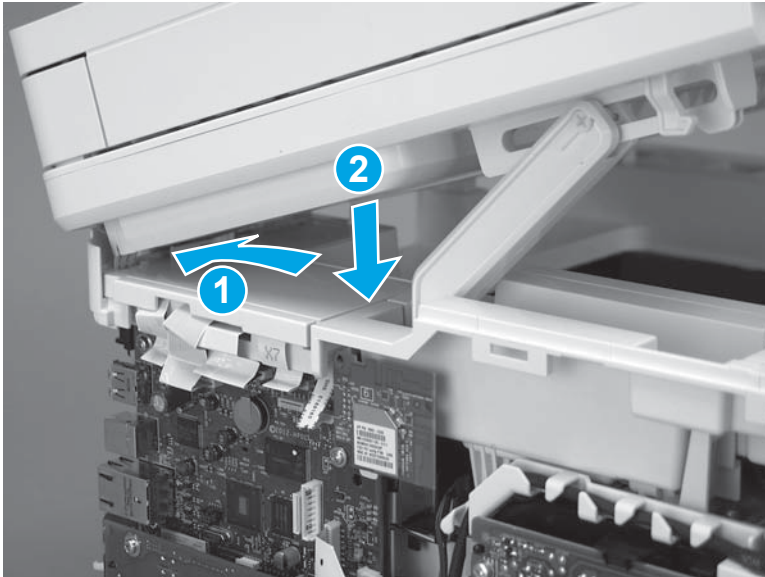

10. Lower the ISA.

Figure 1-1529 Lower the ISA

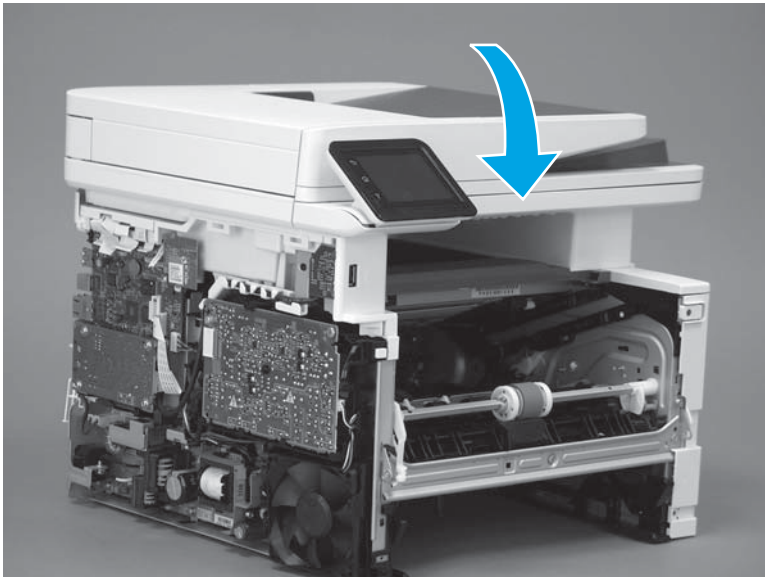

Step 20: Install the right cover

1. Position the cover (callout 1) on the printer, and then engage two bosses (callout 2).

Figure 1-1530 Install the cover

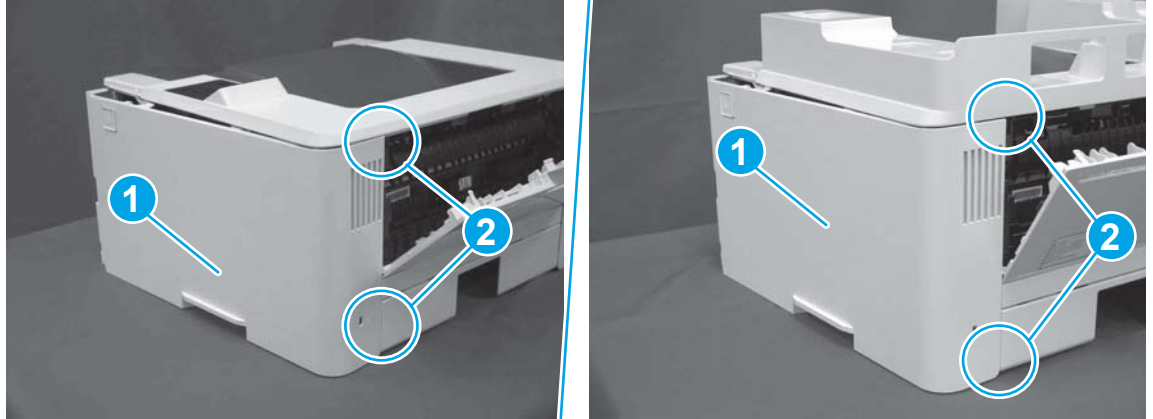

2. Rotate the front of the cover onto the printer (callout 1), engage three (callout 2) tabs, and then engage two bosses (callout 3).

Figure 1-1531 Engage two bosses and one tab

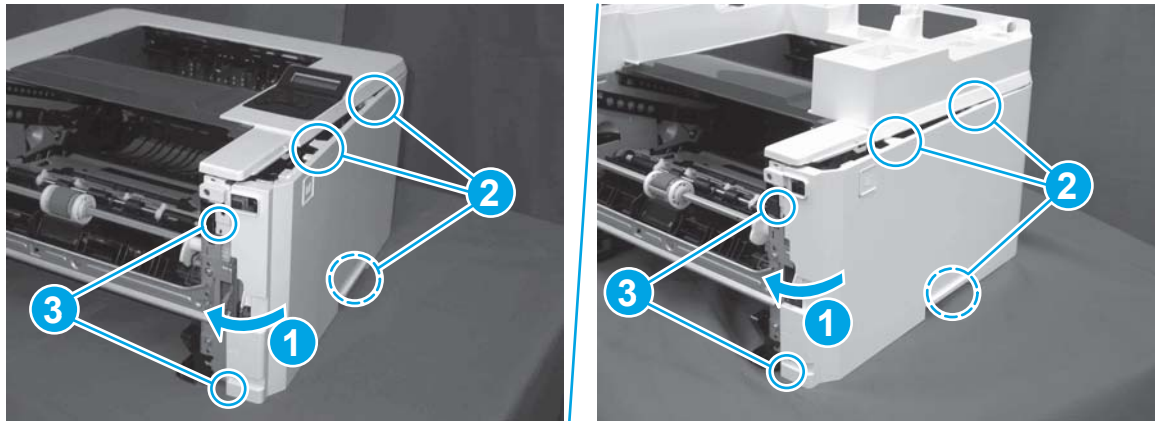

3. Make sure that the power switch (callout 1) and cartridge door assembly button (callout 2) correctly function.



NOTE: Remove, and then reinstall the cover if the switch or button does not correctly function.

Figure 1-1532 Check the power switch and cartridge door assembly button

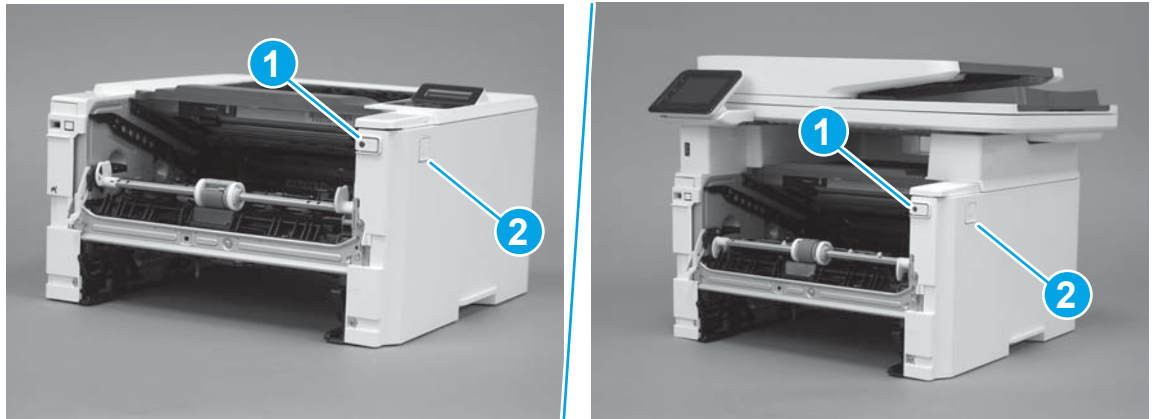

4. Install one screw (callout 1).

Figure 1-1533 Install one screw



Step 21: Install the left cover

1. At the front of the printer, do one of the following:
 - **M403/M402:** Position the cover on the printer (callout 1), and then engage two bosses (callout 2).
 - **M427/M426:** Position the cover on the printer (callout 3), engage one tab (callout 4), and then engage two bosses (callout 4).

Figure 1-1534 Install the cover

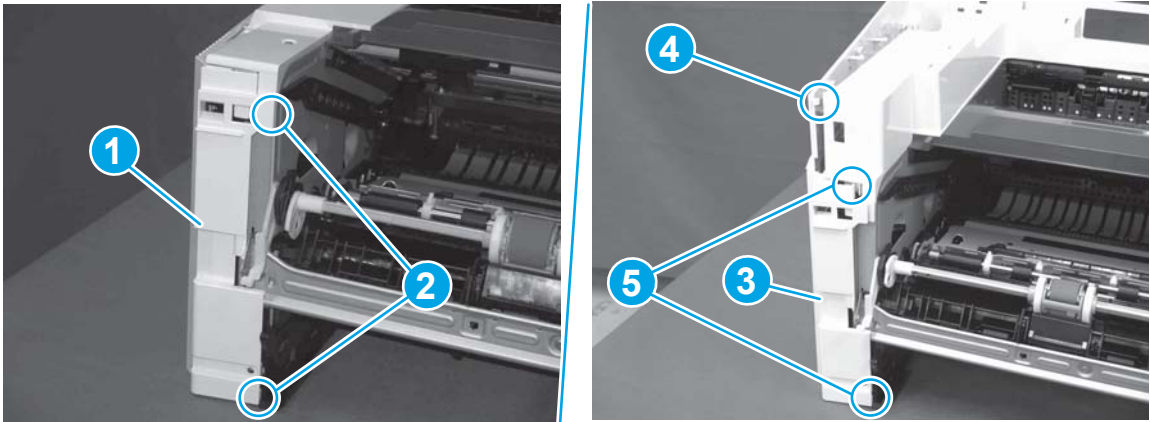

- Carefully rotate the rear of the cover onto the printer (callout 1), engage three tabs (callout 2), and then engage two bosses (callout 3).

Figure 1-1535 Engage three tabs and two bosses

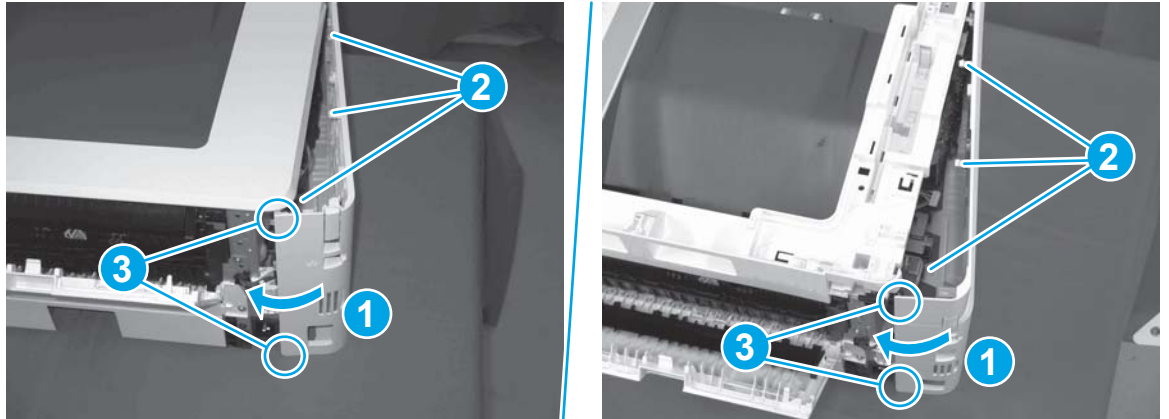

- Install one screw (callout 1).

Figure 1-1536 Install one screw

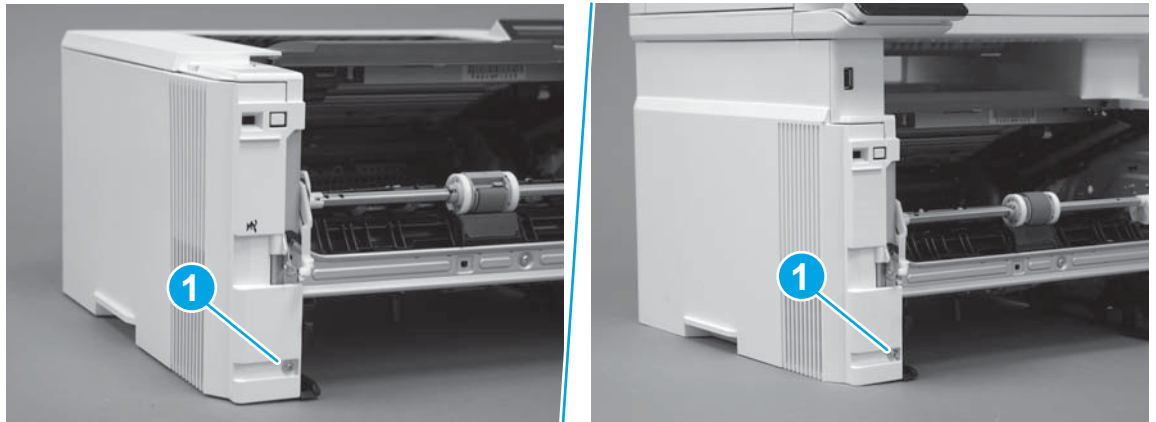

Step 22: Install the cartridge door assembly

 **Reinstallation tip:** After a replacement door is installed, make sure to install the nameplate (supplied in the kit) corresponding to the printer name on the door.

- Position the door close to the printer, and then engage the keyed pin on the left-side retainer arm with the hole in the door.

Figure 1-1537 Engage the left-side retainer arm

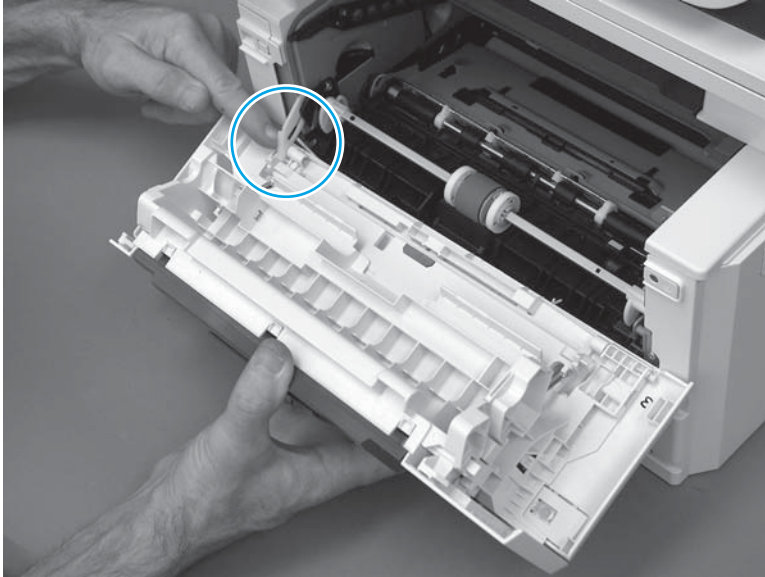

2. Engage the right-side door hinge pin with the hole in the chassis (callout 1).

Figure 1-1538 Install the door

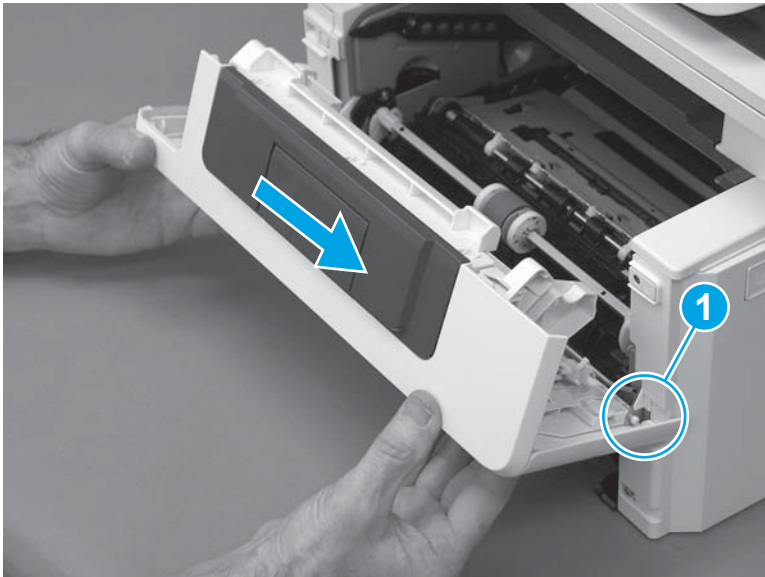

3. Install the link (callout 1).

 **IMPORTANT:** Make sure that the link snaps into place on the arm (callout 2). The link actuates the fuser pressure-release mechanism.

Figure 1-1539 Install the pressure-release link

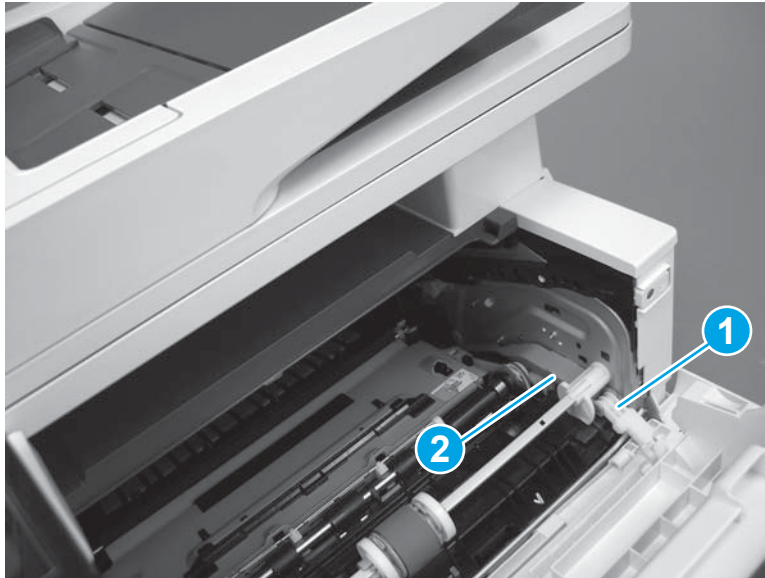

4. Slide the guide into the printer (callout 1), and then make sure that the tab (callout 2) snaps into place to secure the guide to the chassis.

Figure 1-1540 Install the guide

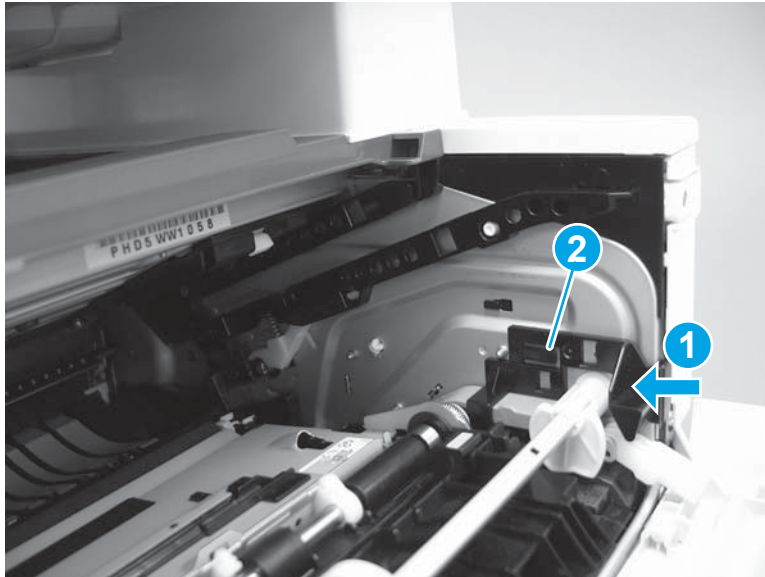

5. Position the shaft on the door, and then align the left-side hinge on the door with the hole in the chassis (callout 1).

Figure 1-1541 Align the hinge

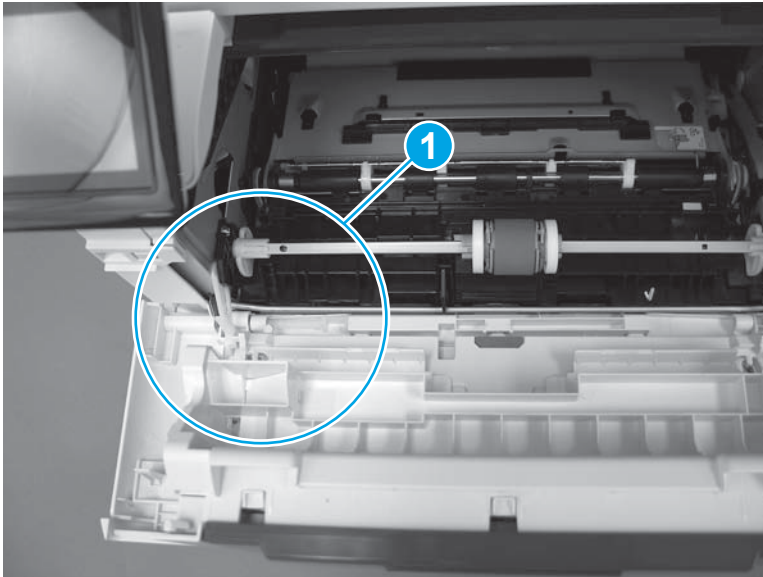

6. Push the shaft towards the left side of the printer to install it (callout 1).

 **Reinstallation tip:** Make sure that the support shaft is fully installed and correctly orientated (callout 2) so that it will not interfere with the door opening and closing.

Figure 1-1542 Install the support shaft



Step 23: Install Tray 2

- ▲ Slide the tray straight into the printer to install it.

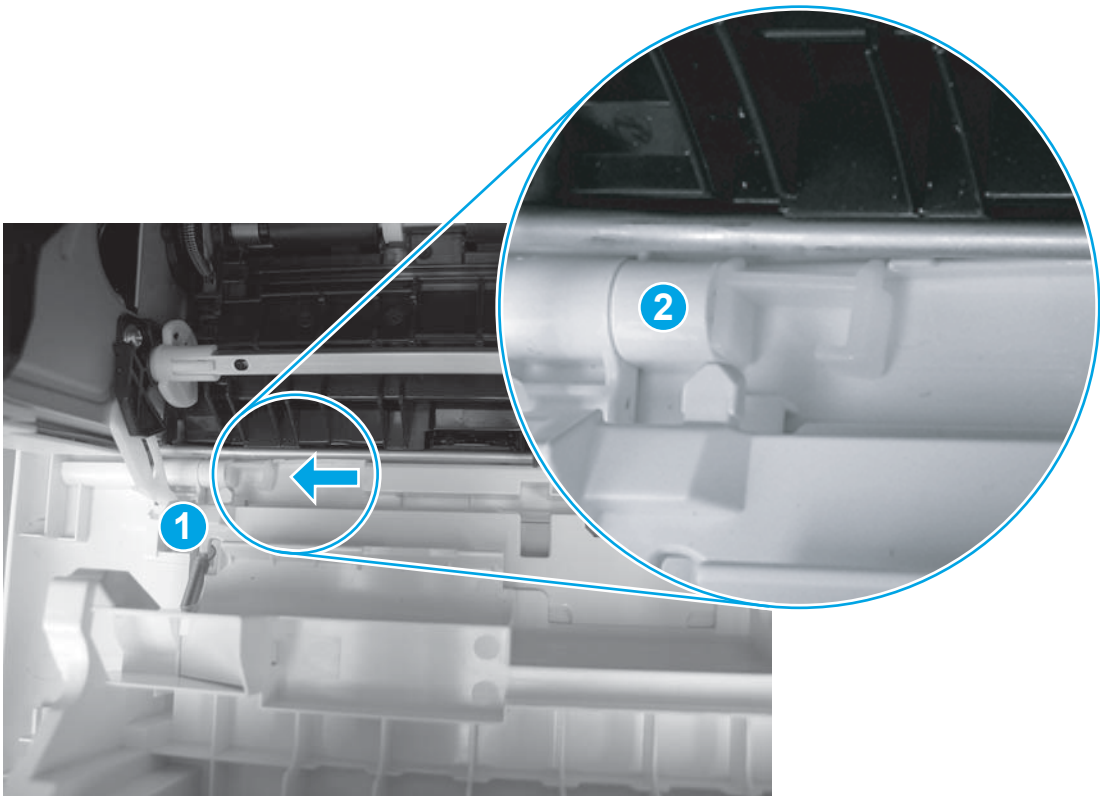
Figure 1-1543 Install the tray



Removal and replacement: Connecting PCA

- [Introduction](#)
- [Step 1: Remove Tray 2](#)
- [Step 2: Remove the cartridge door assembly](#)
- [Step 3: Remove the left cover](#)
- [Step 4: Remove the right cover](#)
- [Step 5: Remove the integrated scanner assembly \(M427/M246\)](#)
- [Step 6: Remove the control panel \(M427/M246\)](#)
- [Step 7: Remove the top cover \(M427/M426\)](#)
- [Step 8: Remove the top cover \(M403/M402\)](#)
- [Step 9: Remove the paper delivery tray \(output bin\)](#)
- [Step 10: Remove the sheet-metal formatter bracket and formatter PCA](#)
- [Step 11: Remove the connecting PCA](#)
- [Step 12: Unpack the replacement assembly](#)
- [Step 13: Install the connecting PCA](#)
- [Step 14: Install the sheet-metal formatter bracket and formatter PCA](#)
- [Step 15: Install the paper delivery tray \(output bin\)](#)
- [Step 16: Install the top cover \(M403/M402\)](#)
- [Step 17: Install the top cover \(M427/M426\)](#)
- [Step 18: Install the control panel \(M427/M246\)](#)
- [Step 19: Install the integrated scanner assembly \(M427/M246\)](#)
- [Step 20: Install the right cover](#)
- [Step 21: Install the left cover](#)
- [Step 22: Install the cartridge door assembly](#)
- [Step 23: Install Tray 2](#)

Introduction

This document provides the procedures to remove and replace the connecting printed circuit assembly (PCA).

Before performing service

Turn the printer power off

- Disconnect the power cable.

 **WARNING!** To avoid damage to the printer, turn the printer off, wait 30 seconds, and then remove the power cable before attempting to service the printer.

Use the table below to identify the correct part number for your printer. To order the part, go to www.hp.com/buy/parts.

Connecting printed circuit assembly (PCA) part number	
RM2-7510-000CN	Connecting PCA (duplex models ¹)
RM2-8510-000CN	Connecting PCA (simplex models)

¹ All M426/M427 printers are duplex models and use the RM2-7510-000CN connecting PCA.

Required tools

- #2 Phillips screwdriver with a magnetic tip.
- 5.5 mm (0.22 inch) socket screwdriver.

After performing service

Turn the printer power on

- Connect the power cable.
- Use the power switch to turn the power on.

Post service test

Make sure that the printer initializes to a **Ready** state.

Print a configuration page to make sure that the printer is functioning correctly.

Step 1: Remove Tray 2

- ▲ Pull the tray straight out of the printer to remove it.

Figure 1-1544 Remove the tray



Step 2: Remove the cartridge door assembly



NOTE: If the toner cartridge was not removed prior to servicing the printer, remove it now.

1. Release one tab (callout 1), and then slide shaft (callout 2) in the direction the arrow indicates and remove it.



TIP: It might be easier to release the support shaft by using a small flat-blade screwdriver.

Figure 1-1545 Release the support shaft

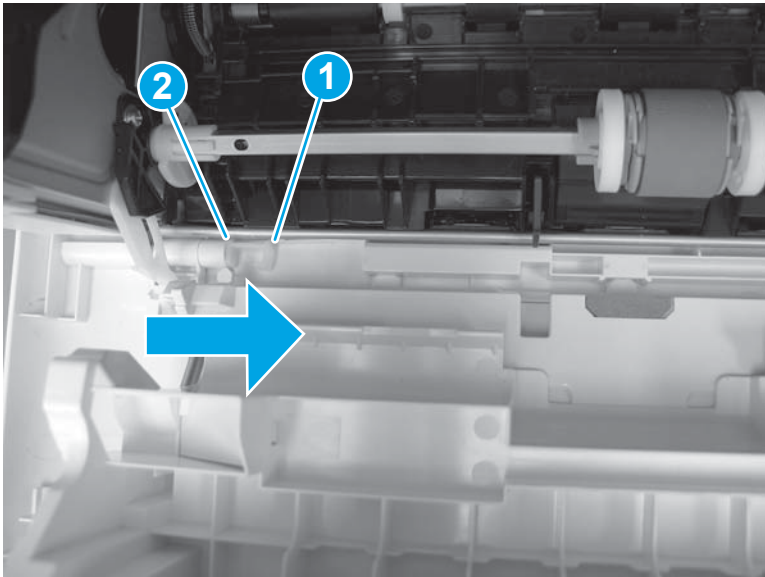

2. Release one tab (callout 1), and then slide the guide (callout 2) in the direction the arrow indicates and remove it.

Figure 1-1546 Remove the guide

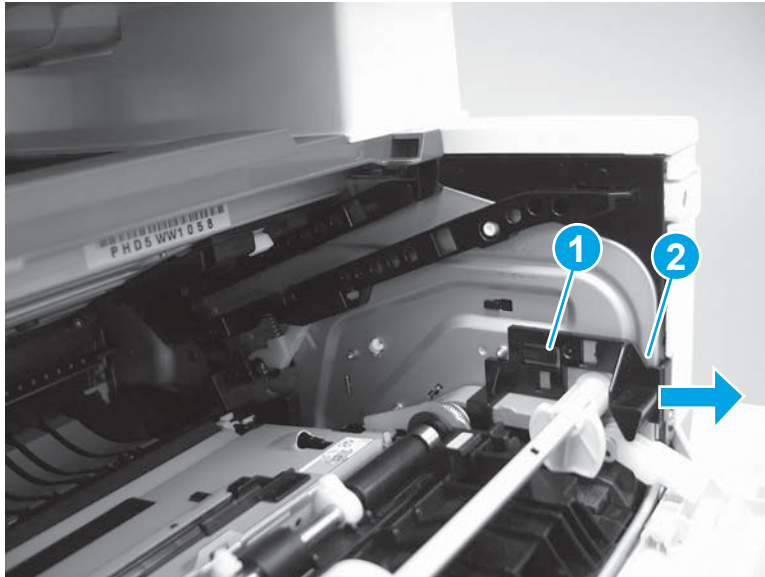

3. Remove the link arm (callout 1).

Figure 1-1547 Remove the link arm

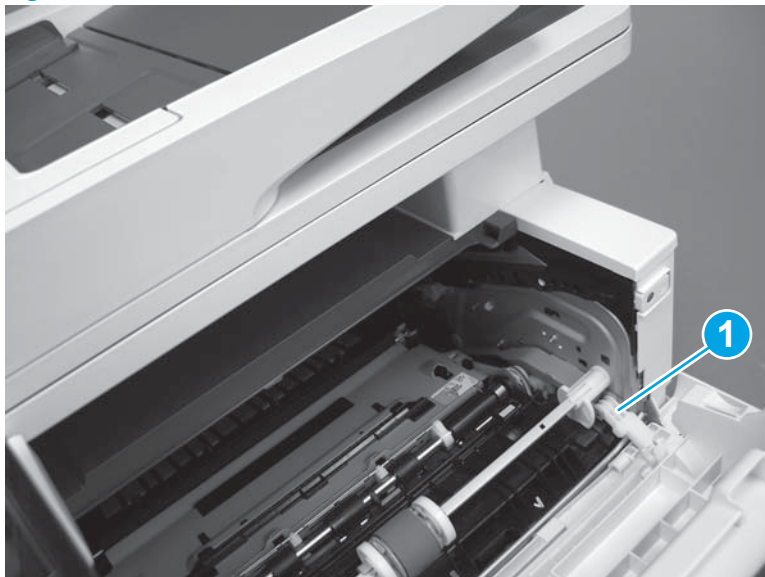

4. Slide the cartridge door assembly (callout 1) in the direction the arrow indicates and remove it.

Figure 1-1548 Remove the door

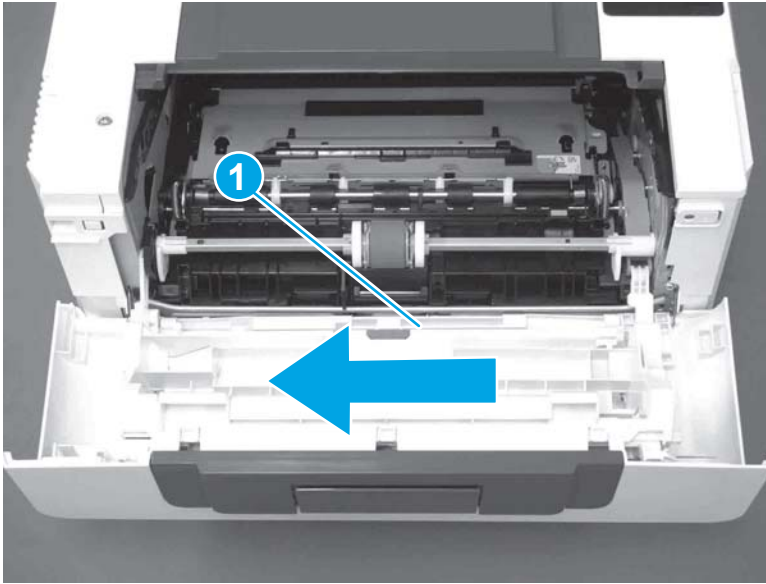

5. Remove the link (callout 1) from the cartridge door assembly (callout 2).

Figure 1-1549 Release the left-side retainer arm

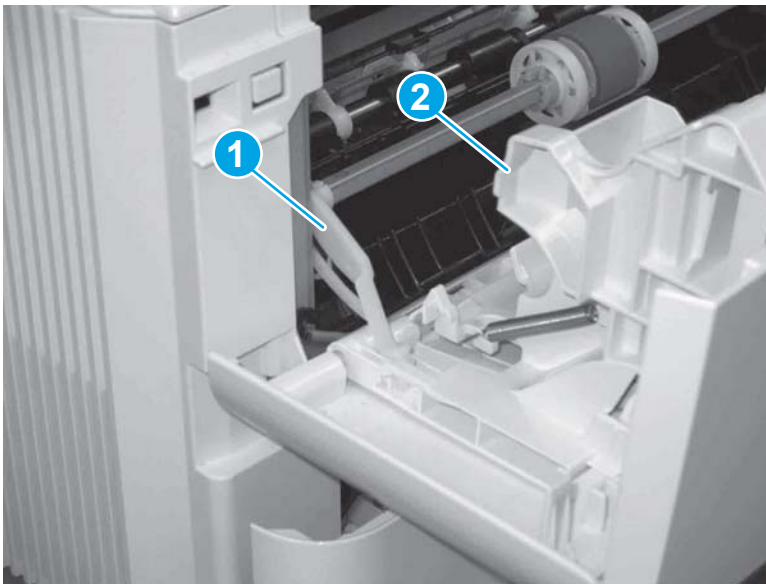

Step 3: Remove the left cover

1. Remove one screw (callout 1).

Figure 1-1550 Remove one screw

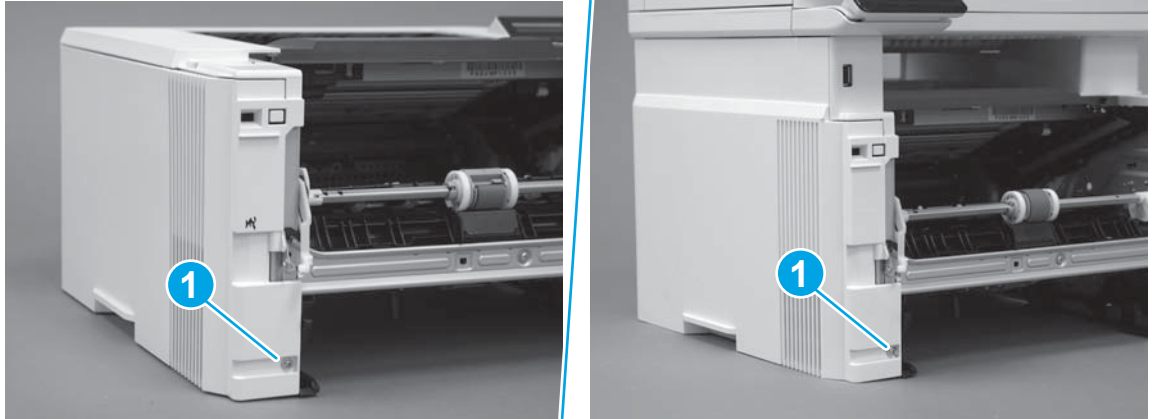

2. Open the rear door, release two bosses (callout 1), and then release three tabs (callout 2).

Figure 1-1551 Release two bosses and three tabs

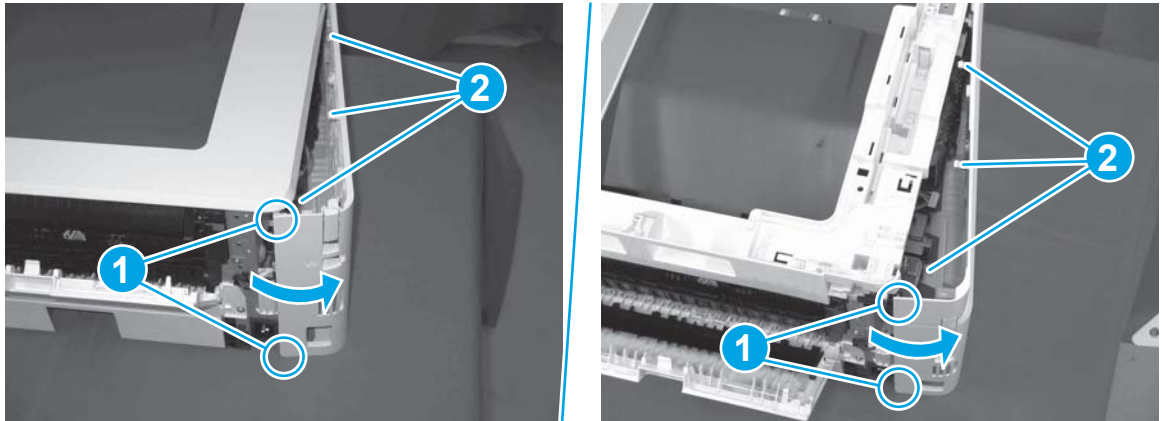

3. At the front of the printer, do one of the following:

- **M403/M402:** Release two bosses (callout 1), and then remove the cover (callout 2).
- **M427/M426:** Release one tab (callout 3), two bosses (callout 4), and then remove the cover (callout 5).

CAUTION: Be careful when releasing the upper bosses on the M427/M426 cover. One portion of the cover (callout 6) is fragile and is easily broken.

Figure 1-1552 Remove the cover

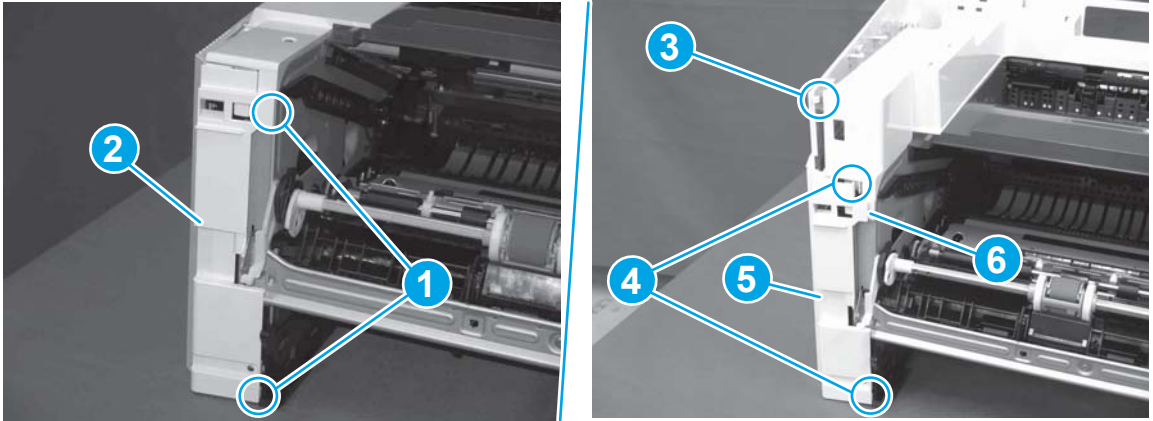

Step 4: Remove the right cover

1. Remove one screw (callout 1).

Figure 1-1553 Remove one screw



2. At the front of the printer, release two bosses (callout 1), and then release three tabs (callout 2).

Figure 1-1554 Release two bosses and three tabs

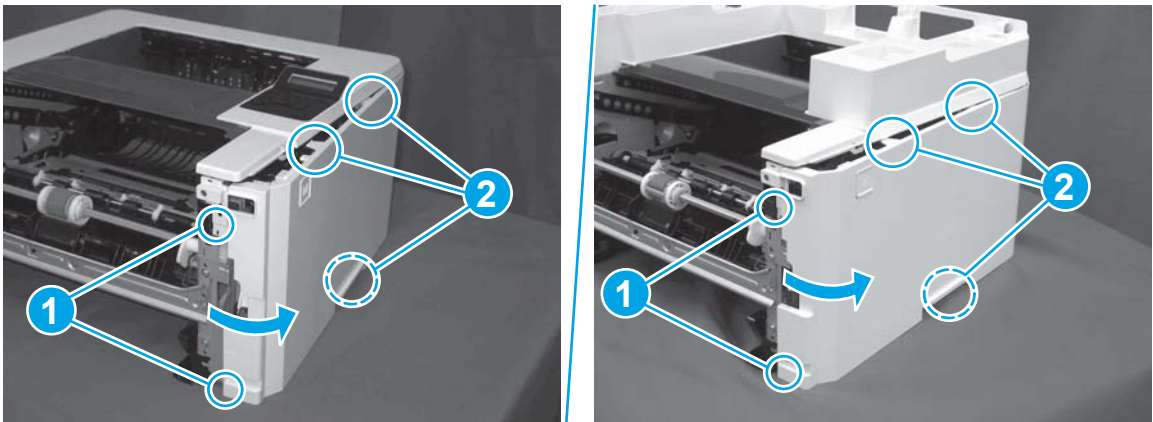

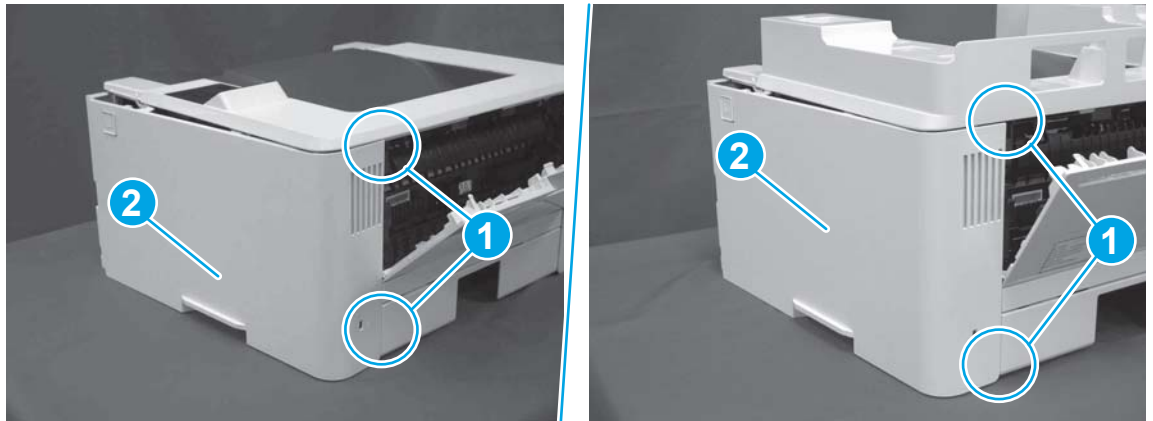

3. Open the rear door, release two bosses (callout 1), and then remove the cover (callout 2).

Figure 1-1555 Remove the cover



Step 5: Remove the integrated scanner assembly (M427/M246)

 **NOTE:** The step is for the M427/M426 printer. For the M403/M402, skip this step and go to [Step 8: Remove the top cover \(M403/M402\)](#) on page 841.

 **NOTE:** M427/M426 models only. The integrated scanner assembly (ISA) includes the sub-scanner assembly (SSA) and the automatic document feeder (ADF).

1. Raise the ISA.

Figure 1-1556 Raise the ISA

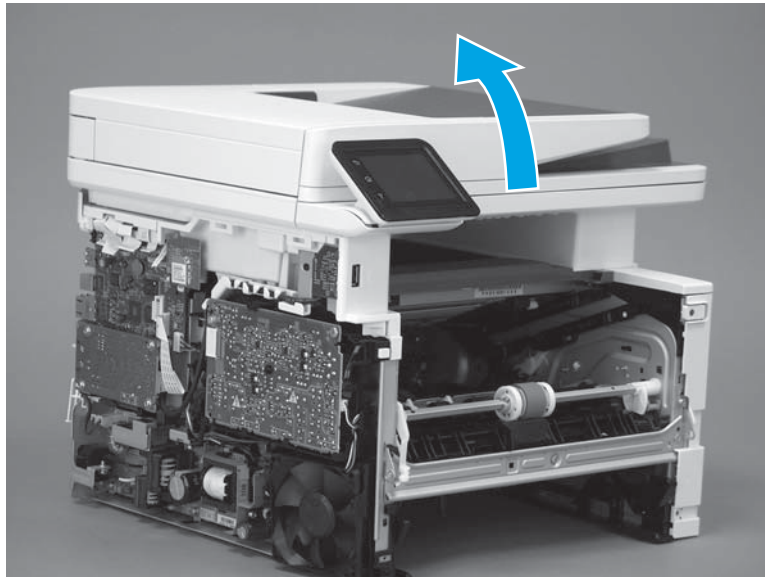

2. Release the ISA flat-flexible cable (FFC) cover (callout 1), and then remove it (callout 2).

Figure 1-1557 Remove the ISA FFC cover

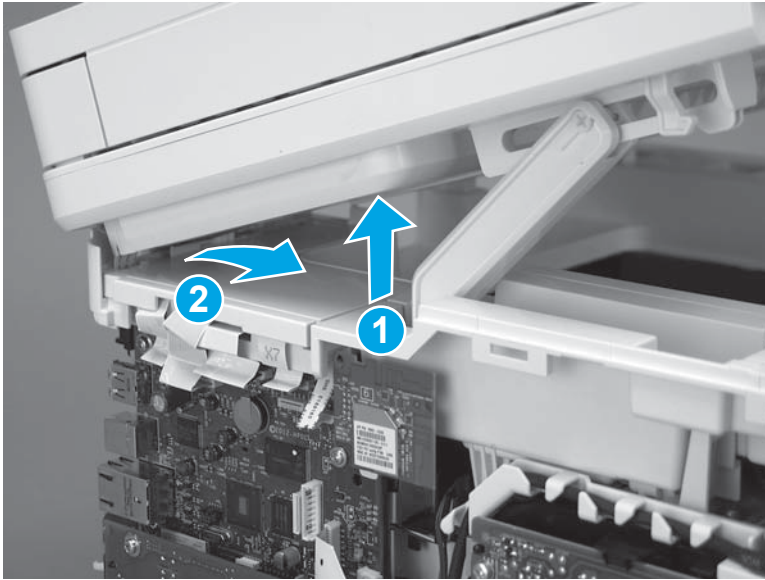

3. Disconnect three FFCs (callout 1), and then remove the ferrite (callout 2) from the holder.

CAUTION: The ferrite is not captive on the FFC. Do not lose the ferrite while handling the ISA.

Figure 1-1558 Disconnect three FFCs

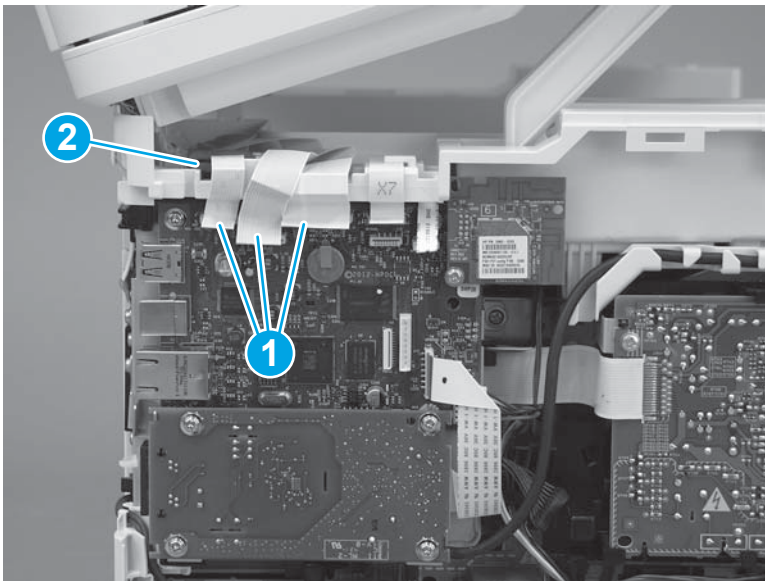

4. Remove one screw (callout 1).

Figure 1-1559 Remove one screw

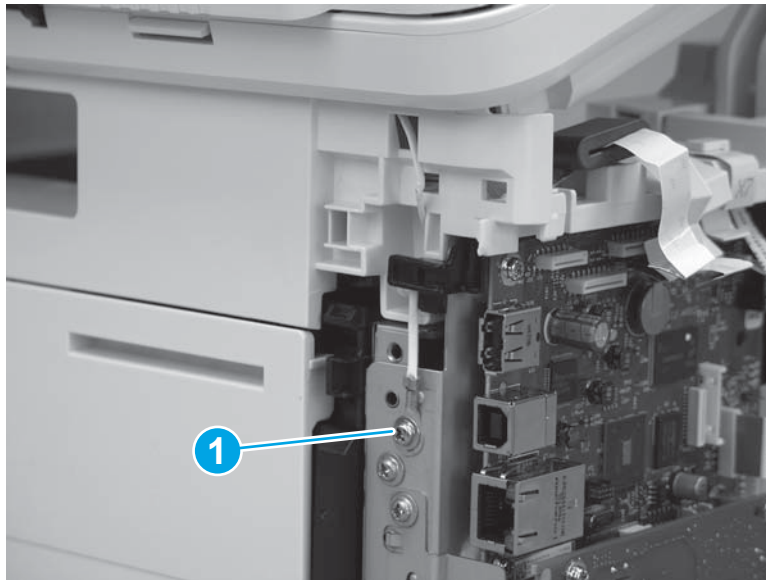

5. Pass the ground wire through the opening in the top cover.

Figure 1-1560 Pass the wire through the opening

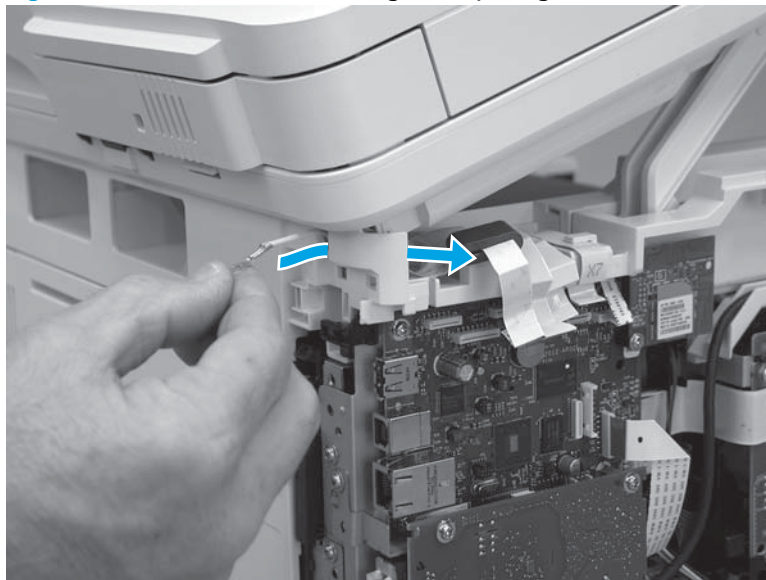

6. Release one tab (callout 1), and then rotate the ISA slider pin (callout 2) towards the front of the printer to release it.

Figure 1-1561 Release one tab and rotate the slider pin

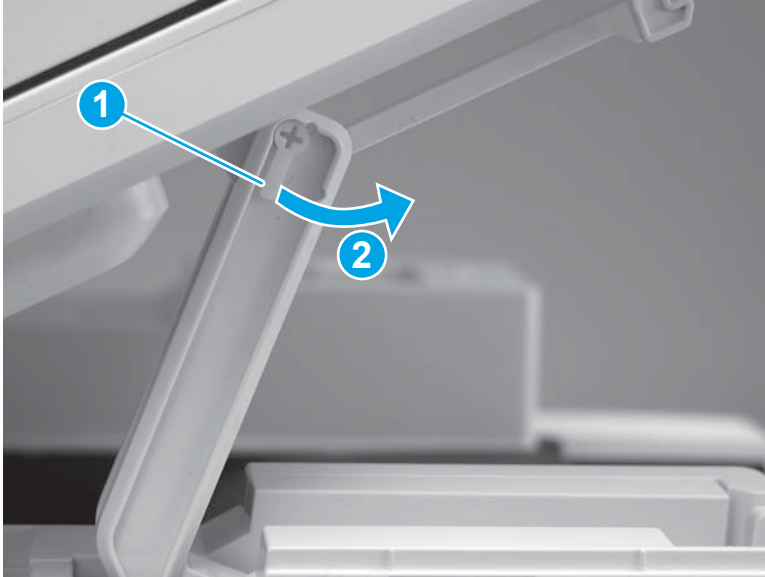

7. Remove the slider pin.

Figure 1-1562 Remove the slider pin

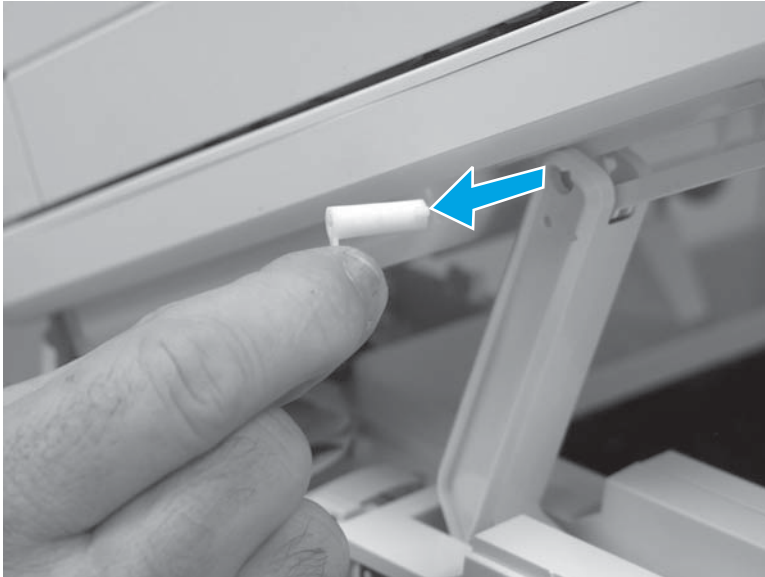

8. Rotate the ISA towards the rear of the printer until it stops.

Figure 1-1563 Rotate the ISA towards the rear of the printer



9. Slide the ISA as shown to release it.

Figure 1-1564 Release the ISA

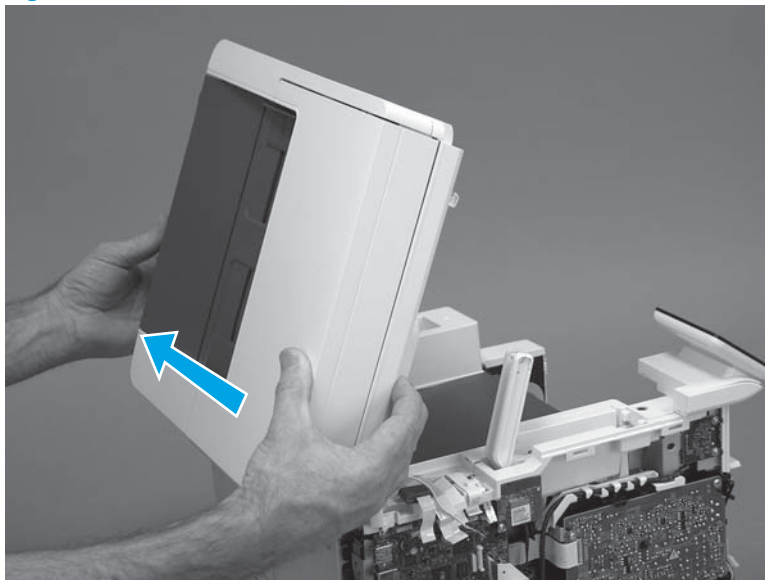

10. Remove the ISA.

Figure 1-1565 Remove the ISA

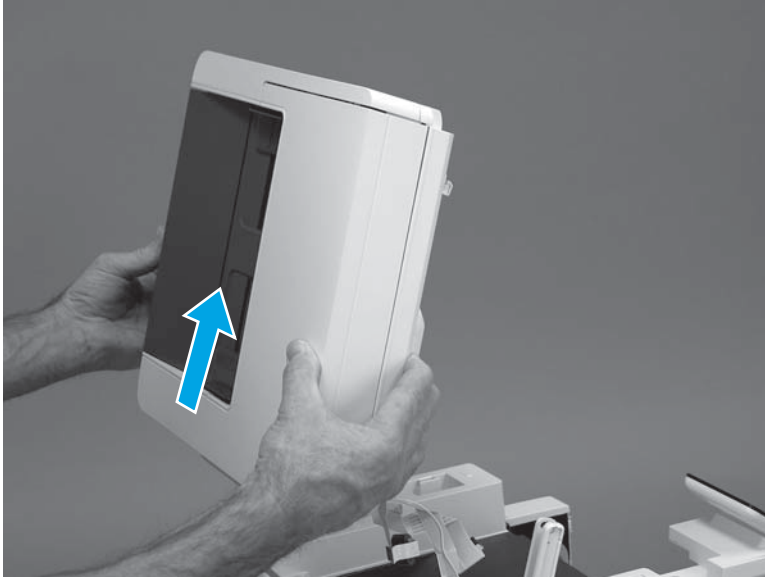

Step 6: Remove the control panel (M427/M246)



NOTE: The step is for the M427/M426 printer. For the M403/M402, skip this step and go to [Step 8: Remove the top cover \(M403/M402\) on page 841](#).

1. Disconnect one FFC (callout 1; J114), and then release the FFC from the retainer (callout 2).

Figure 1-1566 Disconnect one connector

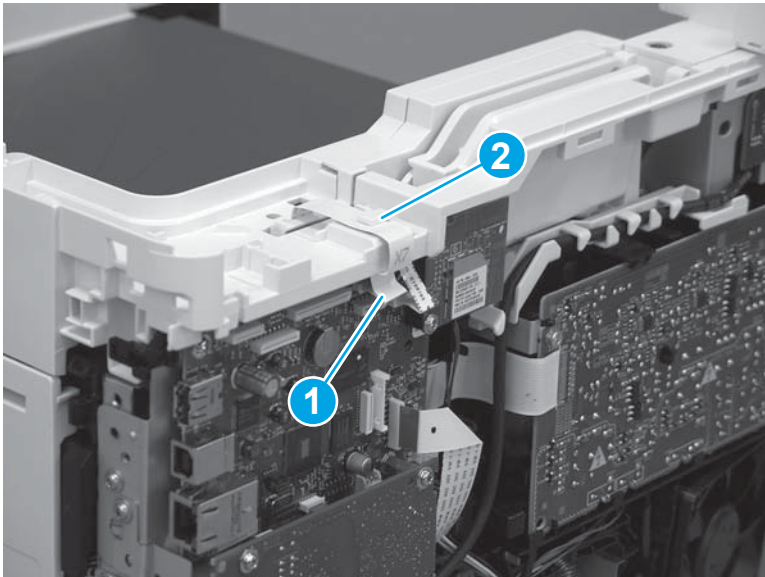

2. Remove one screw (callout 1).

Figure 1-1567 Remove one screw

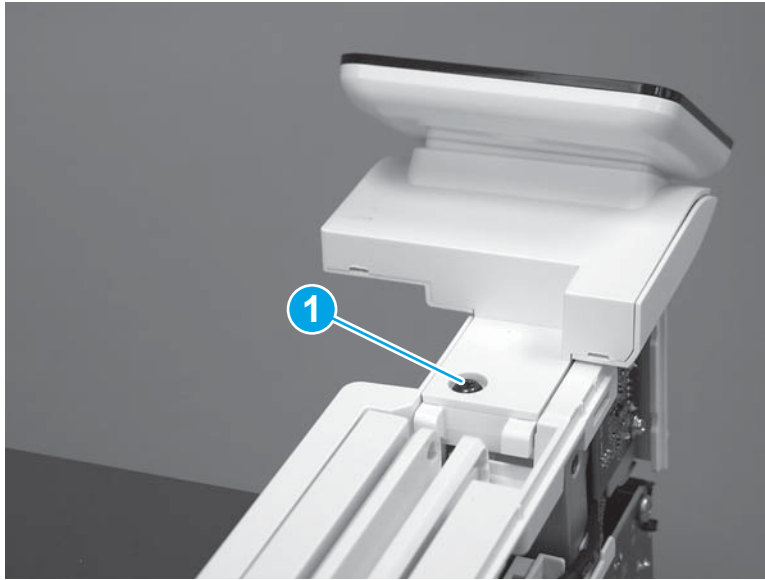

3. Use a small flat-blade screwdriver to release two tabs (callout 1) on the control-panel cable cover.

Figure 1-1568 Release two tabs

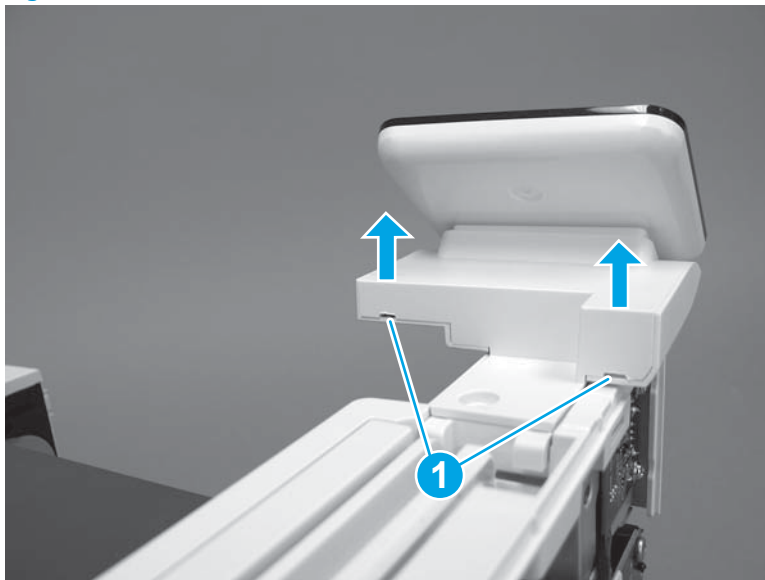

4. Remove the control-panel cable cover.

Figure 1-1569 Remove the cover

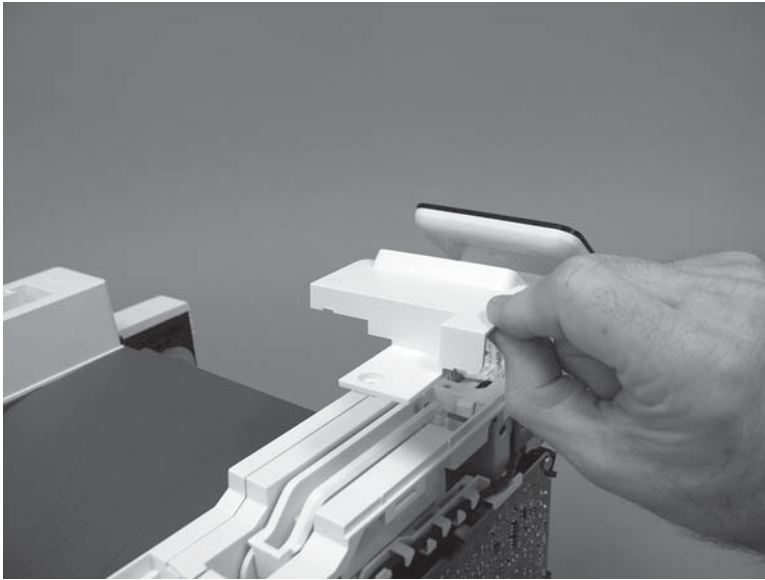

5. Remove one grounding screw (callout 1), and then move the ground cable (callout 2) out of the way.

Figure 1-1570 Remove one screw

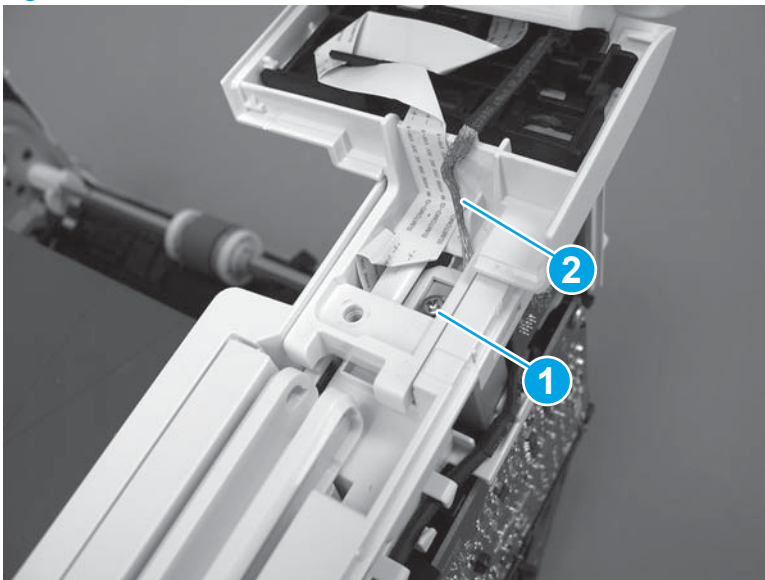

6. Move the FFC out of the way, and then remove two screws (callout 1).

Figure 1-1571 Remove two screws

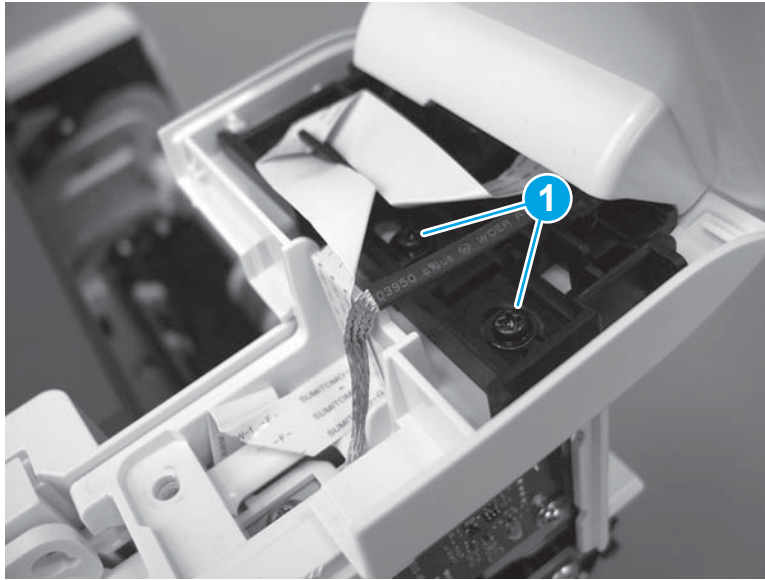

7. Slightly lift up the control-panel assembly to separate it from the top cover.

⚠ CAUTION: The control panel assembly is still connected to the printer by the FFC. Do not attempt to completely remove the assembly.

Figure 1-1572 Lift up the control-panel assembly

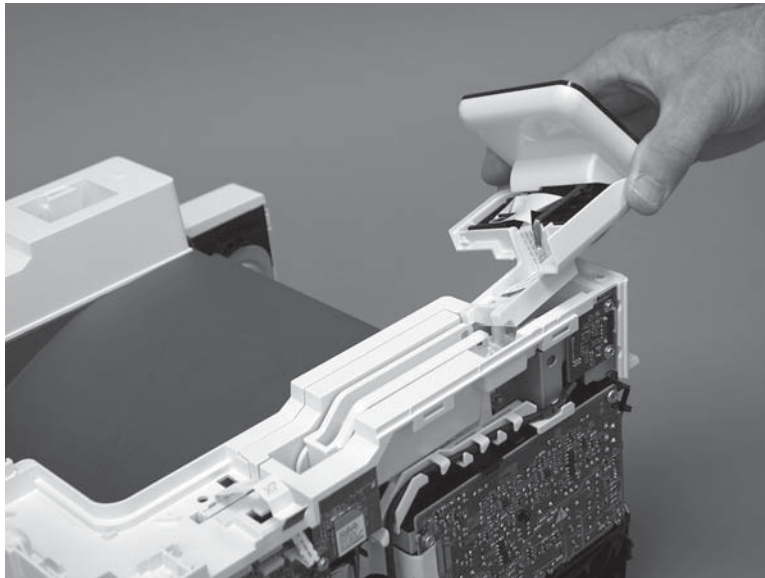

8. Lift up the control-panel FFC cover to remove the control-panel assembly.

Figure 1-1573 Remove the control-panel assembly

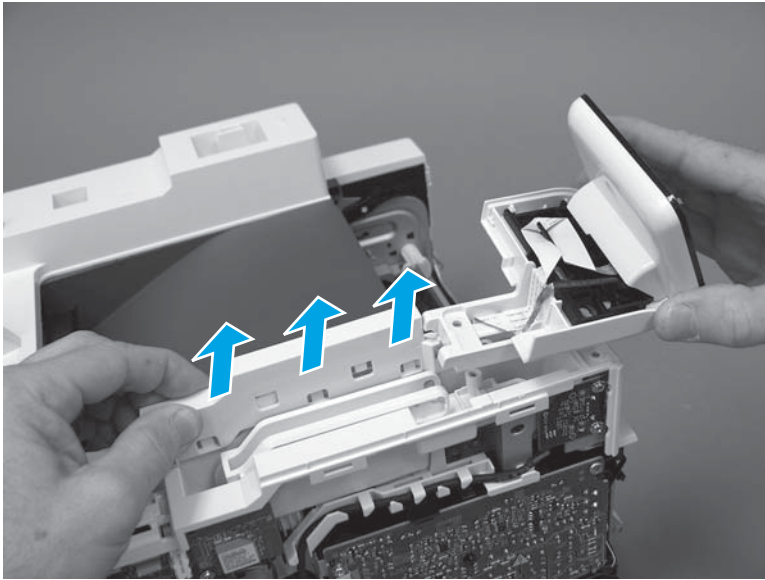

Step 7: Remove the top cover (M427/M426)



NOTE: The step is for the M427/M426 printer. For the M403/M402, skip this step and go to [Step 8: Remove the top cover \(M403/M402\) on page 841](#).

1. Release the USB cable (callout 1) from the cable guide.

Figure 1-1574 Remove the USB cable

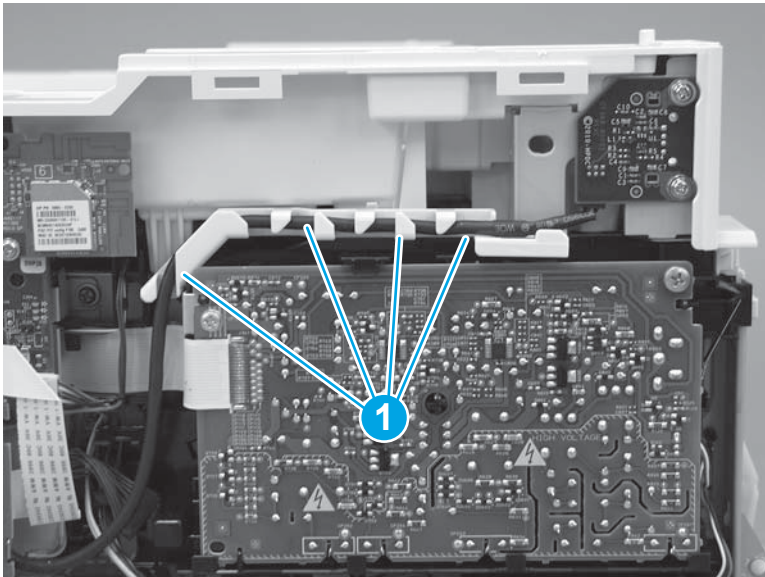

2. Remove five screws (callout 1), release four bosses (callout 2), and then remove the top cover (callout 3).

Figure 1-1575 Remove the cover

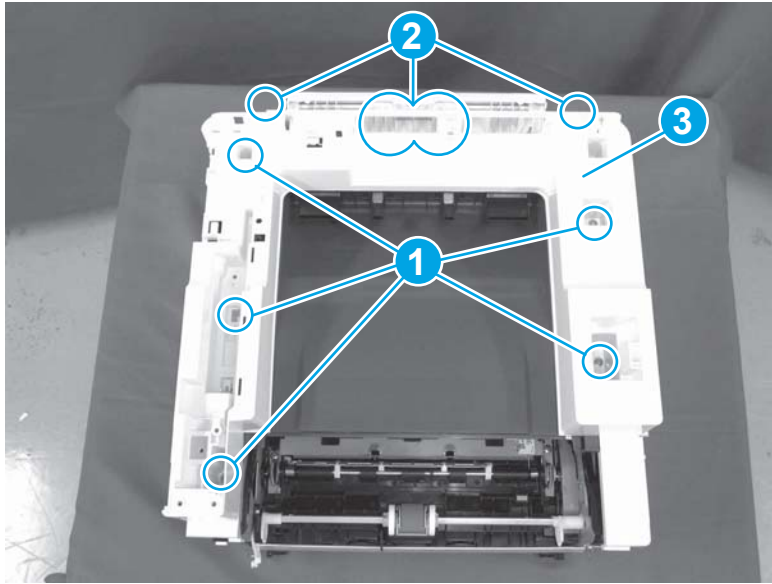

Step 8: Remove the top cover (M403/M402)

 **NOTE:** The step is for the M403/M402 printer. For the M427/M426, skip this step and go to [Step 9: Remove the paper delivery tray \(output bin\) on page 842.](#)

1. Remove one screw (callout 1).

Figure 1-1576 Remove one screw



2. At the right side of the printer, release the one boss (callout 1), and then release one tab (callout 2).

Figure 1-1577 Release one boss and one tab

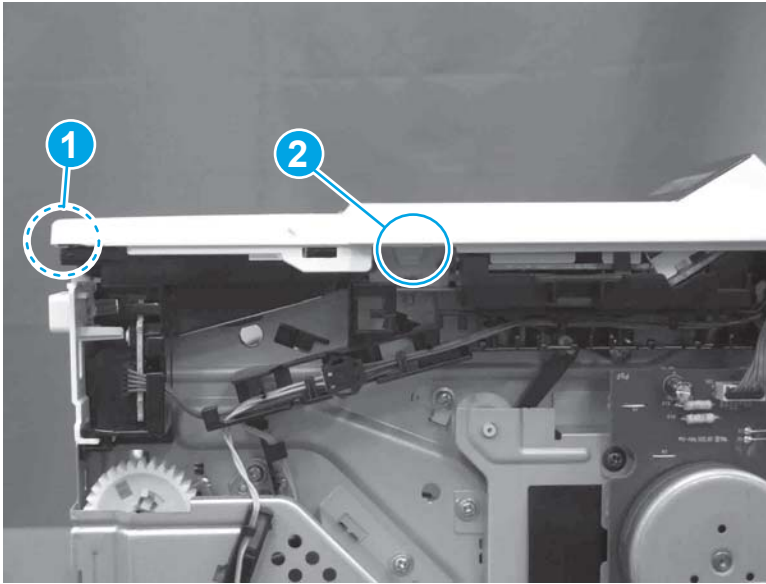

3. Release four tabs (callout 1), release four bosses (callout 2), and then remove the top cover (callout 3).



 **TIP:** Open the rear door to make releasing the bosses (callout 3) easier.

Figure 1-1578 Remove the cover

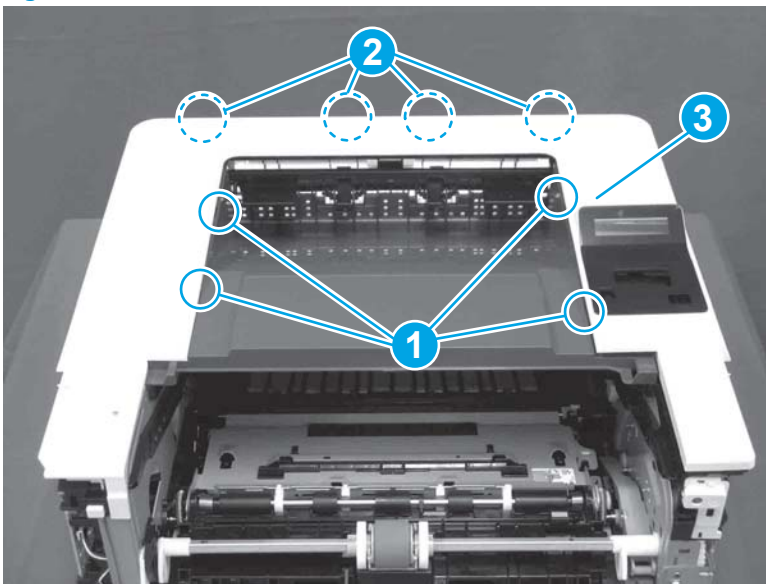

Step 9: Remove the paper delivery tray (output bin)

 **NOTE:** This procedure shows the M403/M402 model, however, the paper delivery tray (output bin) removal is similar for the M427/M426 printer.

- ▲ Release two bosses (callout 1), release two tabs (callout 2), and then remove the paper delivery tray (output bin; callout 3).

Figure 1-1579 Release two tabs

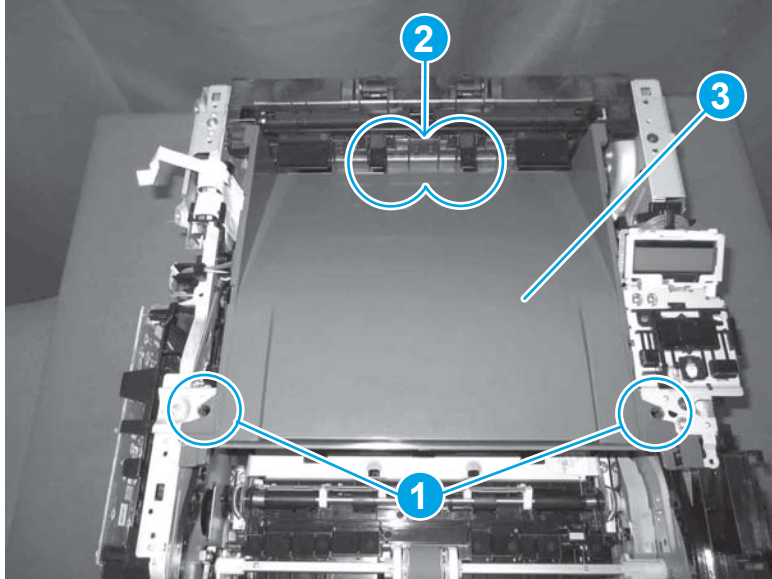

Step 10: Remove the sheet-metal formatter bracket and formatter PCA

 **NOTE:** Disconnect any remaining formatter PCA FFCs or wire-harness connectors.

1. **M427/M426 only:** Remove the guide (callout 1).

Figure 1-1580 Remove the guide

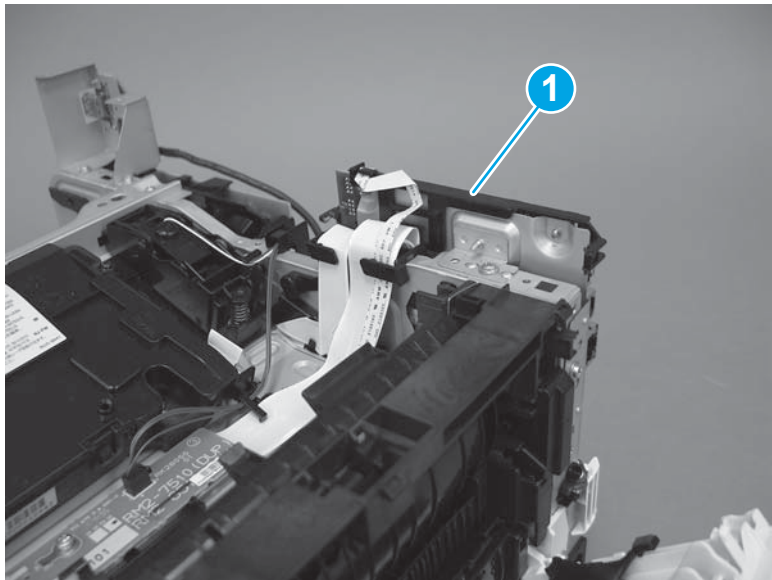

2. Remove two screws (callout 1).

Figure 1-1581 Remove two screws

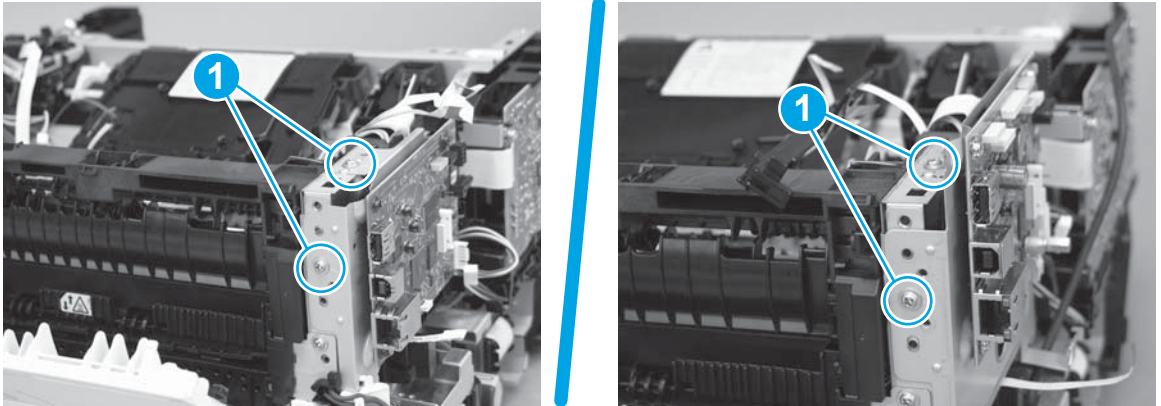

3. Disconnect one connector (callout 1), and then release the wire harness from the guide (callout 2).

Figure 1-1582 Disconnect one connector

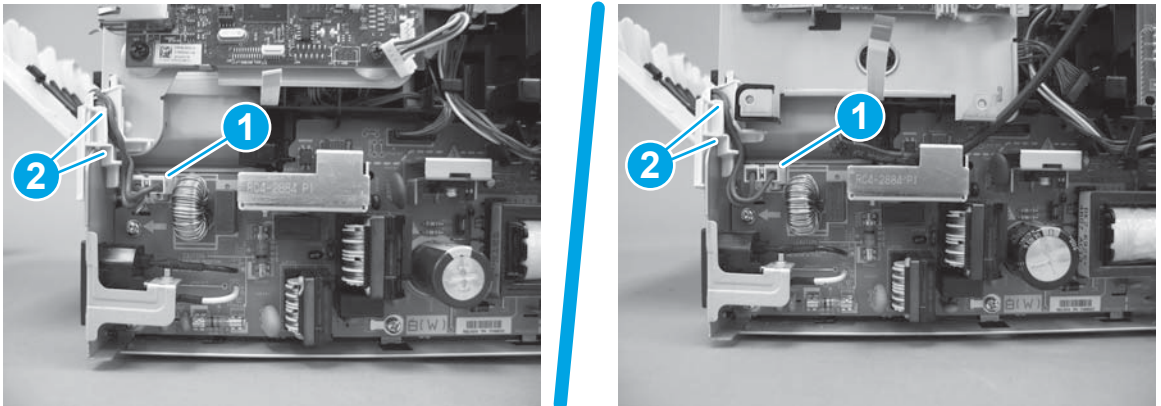

4. Remove the guide (callout 1).

Figure 1-1583 Remove the guide

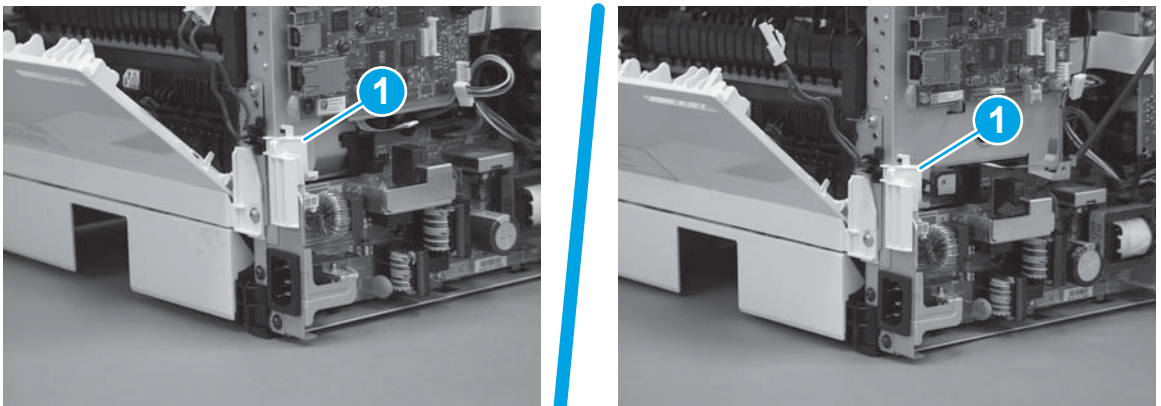

5. Remove three screws (callout 1).

Figure 1-1584 Remove three screws

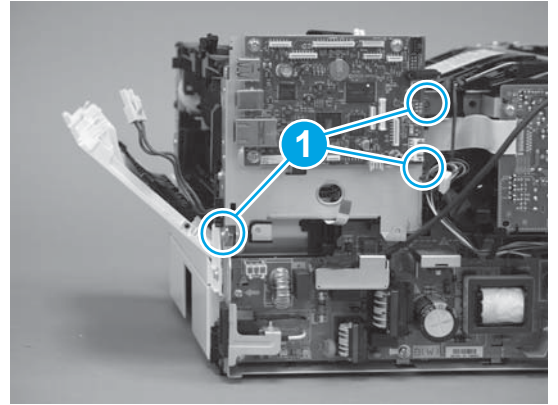
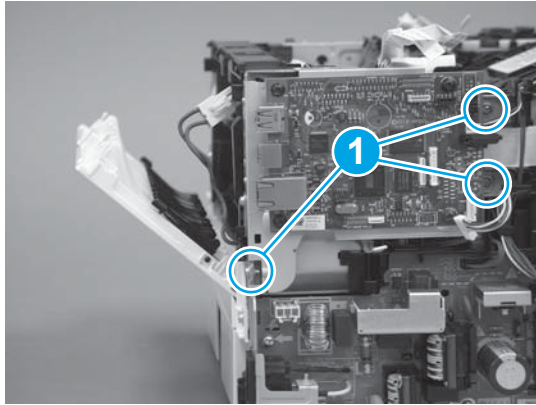

6. Remove the sheet-metal bracket and formatter PCA.

Figure 1-1585 Remove the bracket

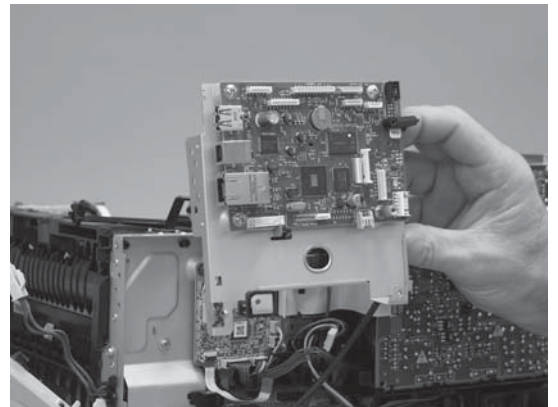
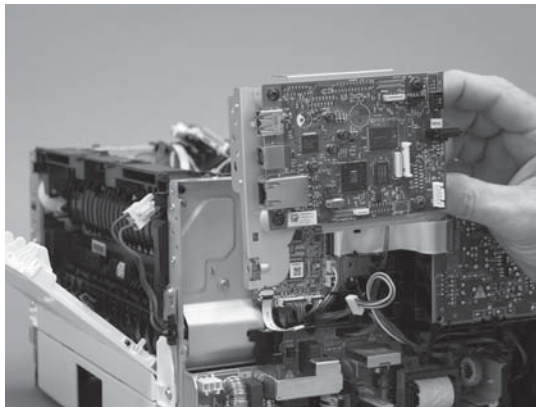

Step 11: Remove the connecting PCA

1. Disconnect nine connectors (callout 1).

 **TIP:** Some of these connectors might be easier to disconnect if the wire harnesses are removed from the guides.

Figure 1-1586 Disconnect nine connectors

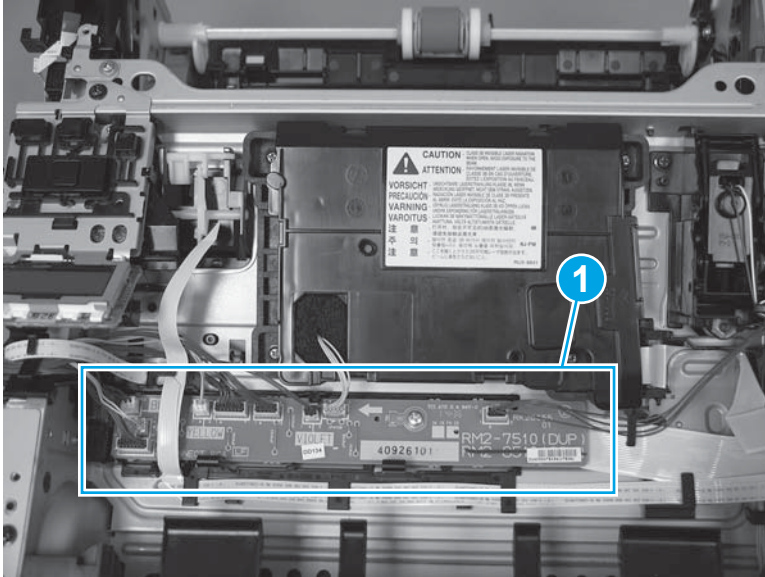

2. Remove one screw (callout 1).

Figure 1-1587 Remove one screw

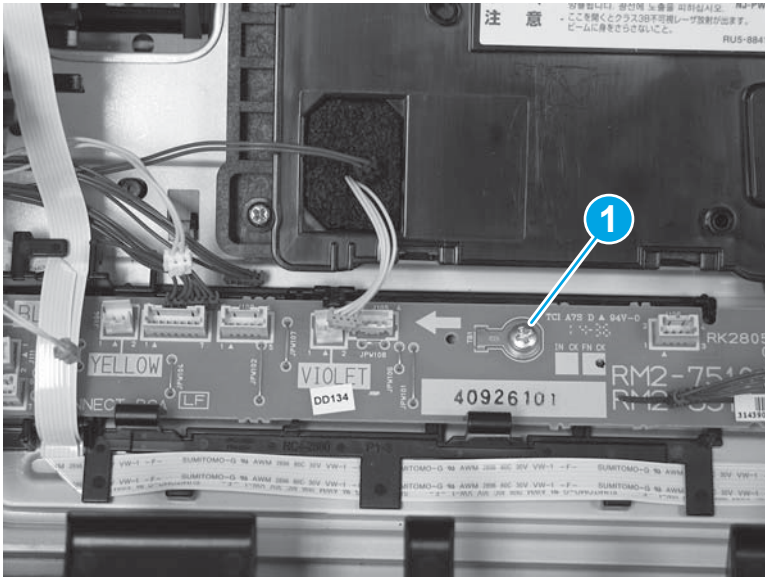

3. Release two holders (callout 1), and then remove the connecting PCA (callout 2).

Figure 1-1588 Remove the connecting PCA

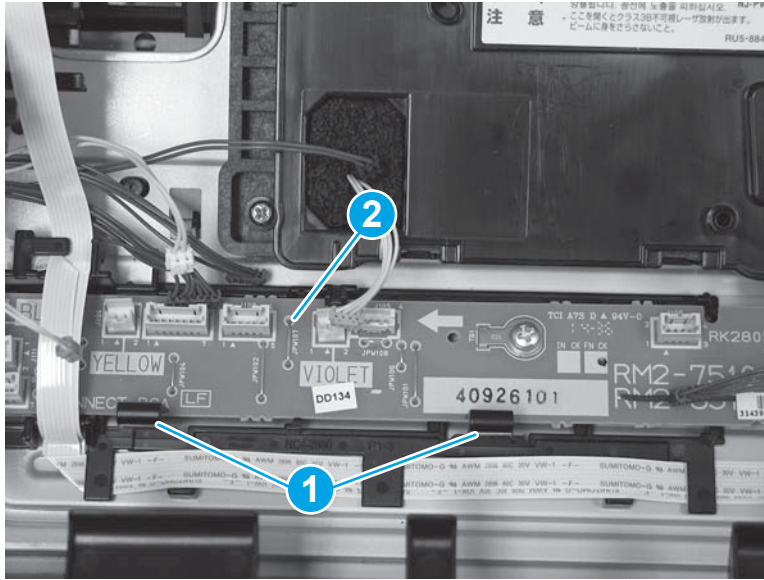

Step 12: Unpack the replacement assembly

Unpack the replacement part from the packaging.

<http://www8.hp.com/us/en/hp-information/environment/product-recycling.html>

 **NOTE:** HP recommends responsible disposal of the defective part.

Figure 1-1589 Recycle and unpack

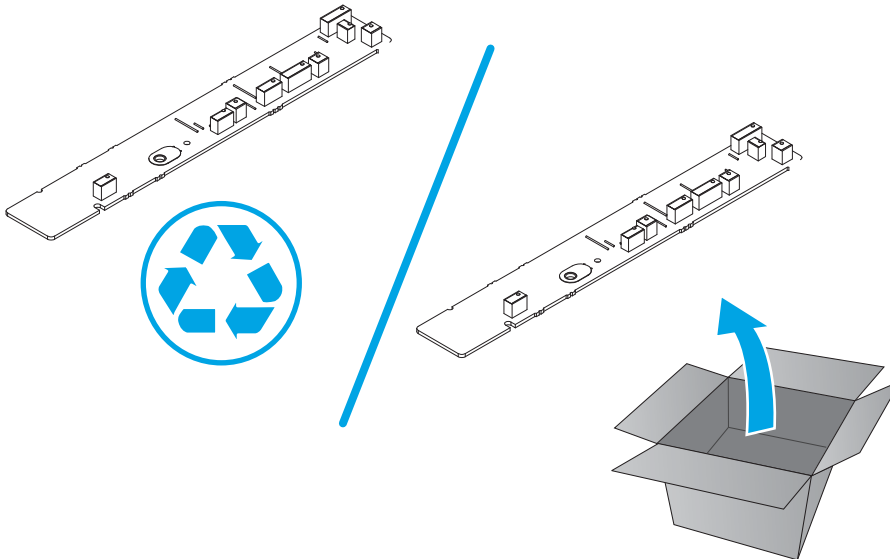

Step 13: Install the connecting PCA

1. Position the connecting PCA (callout 1) under the two holders (callout 2).

Figure 1-1590 Install the connecting PCA

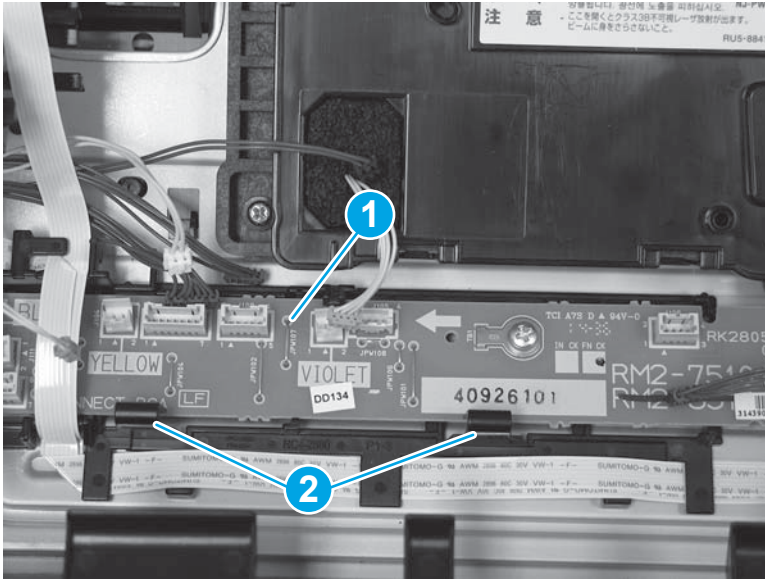

2. Install one screw (callout 1).

Figure 1-1591 Install one screw

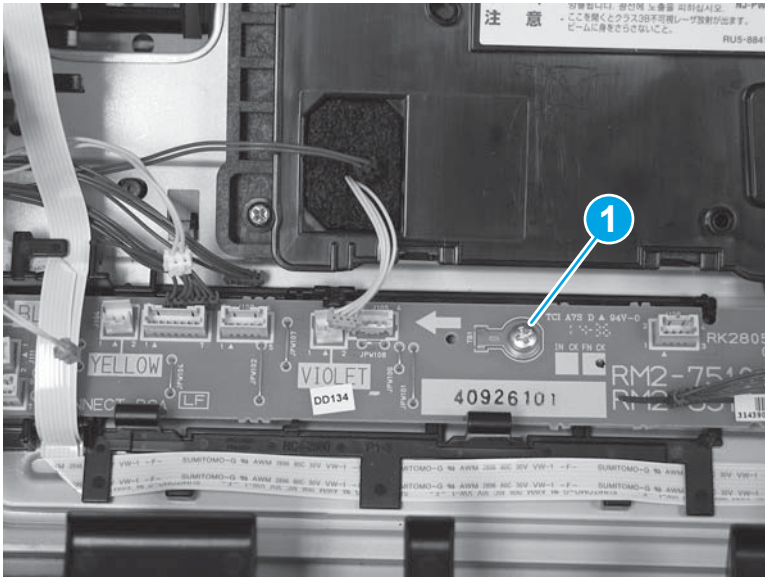

3. Connect nine connectors (callout 1).



 **Reinstallation tip:** If any of the connectors were removed from the guides, make sure that they are reinstalled now.

Figure 1-1592 Connect nine connectors

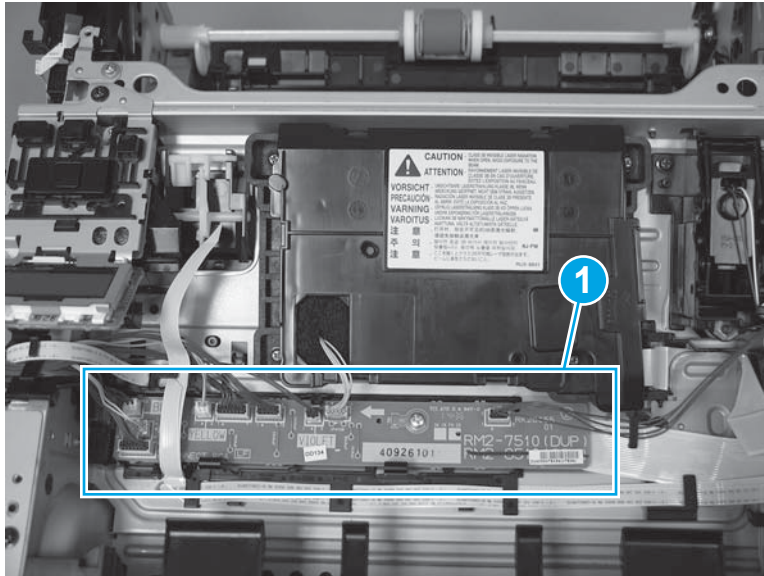

Step 14: Install the sheet-metal formatter bracket and formatter PCA

 **NOTE:** Do not forget to connect any formatter PCA FFCs or wire-harness connectors that were disconnected when the bracket was removed.

1. Position the sheet-metal bracket and formatter PCA on the printer.

Figure 1-1593 Install the bracket

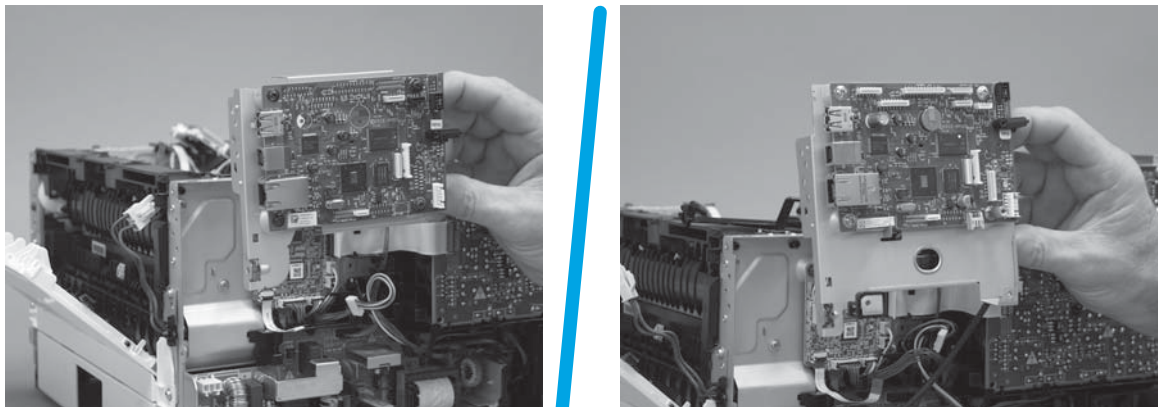

2. Install three screws (callout 1).

Figure 1-1594 Install three screws

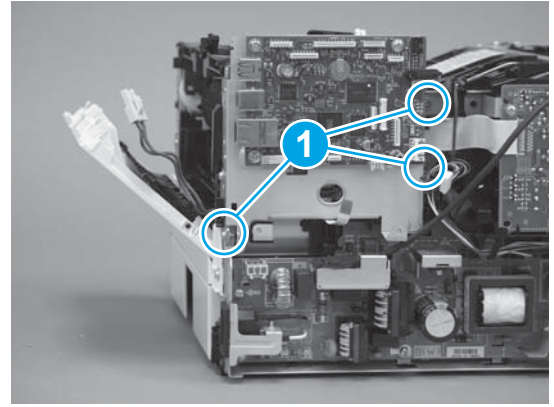
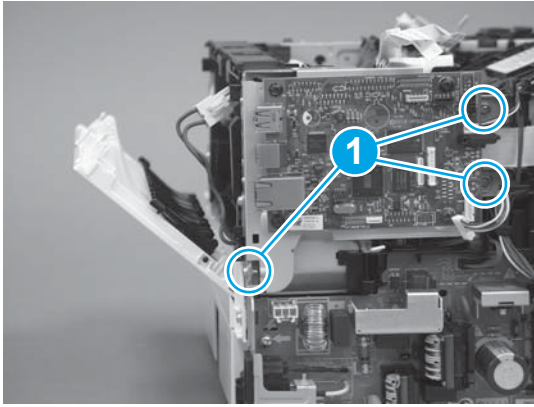

3. Install the guide (callout 1).

Figure 1-1595 Install the guide

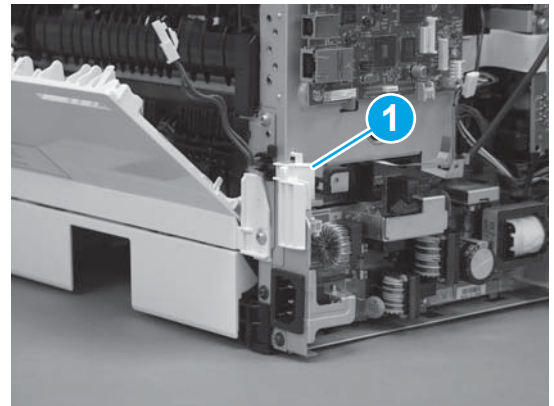
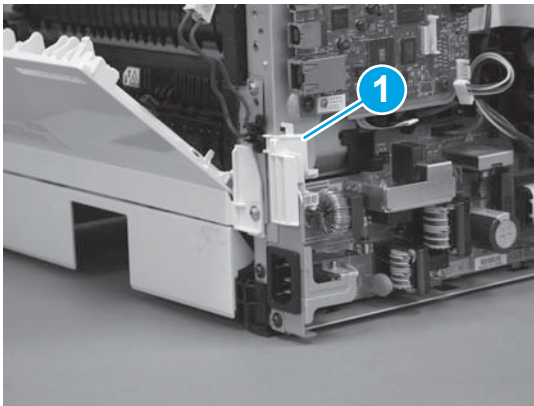

4. Connect one connector (callout 1), and then install the wire harness in the guide (callout 2).

Figure 1-1596 Connect one connector

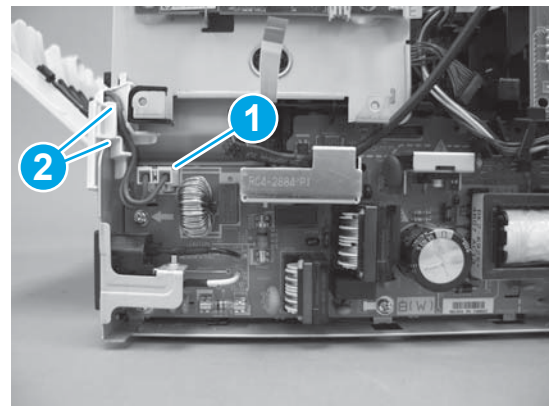
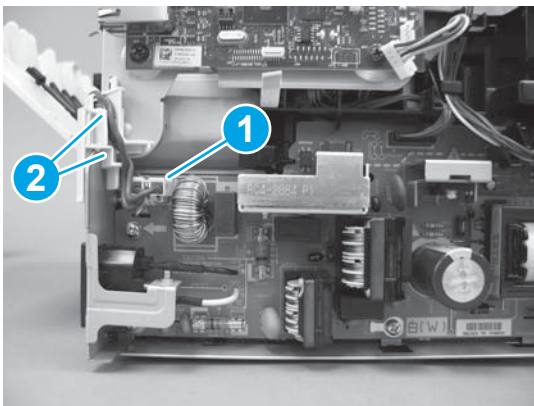

5. Install two screws (callout 1).

Figure 1-1597 Install two screws

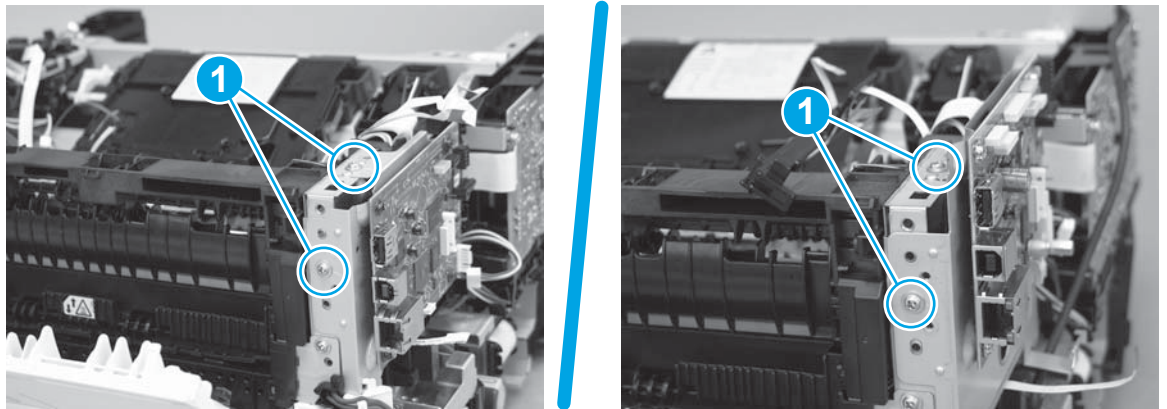

6. **M427/M426 only:** Install the guide (callout 1).

Figure 1-1598 Install the guide

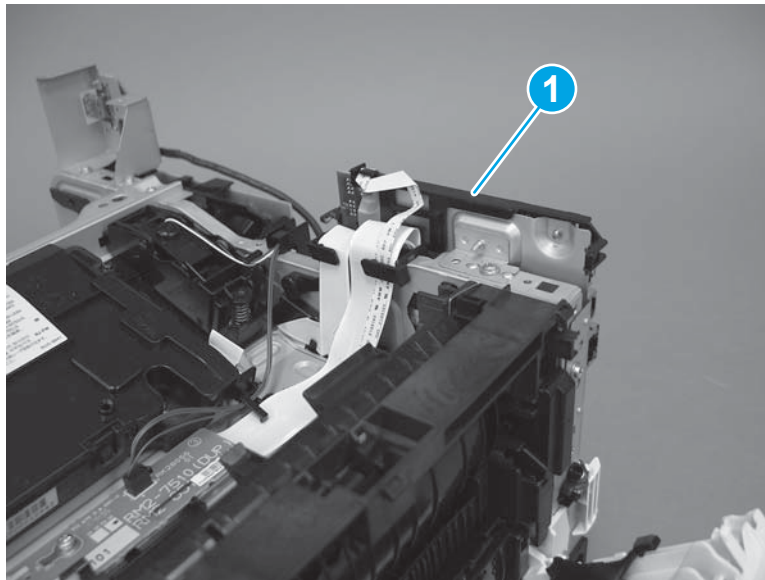

Step 15: Install the paper delivery tray (output bin)

 **NOTE:** This procedure shows the M403/M402 model, however, the paper delivery tray (output bin) removal is similar for the M427/M426 printer.

- ▲ Position the remove the paper delivery tray (output bin; callout 1) on the printer, engage two tabs (callout 2), and then engage two bosses (callout 3).

Figure 1-1599 Engage two tabs

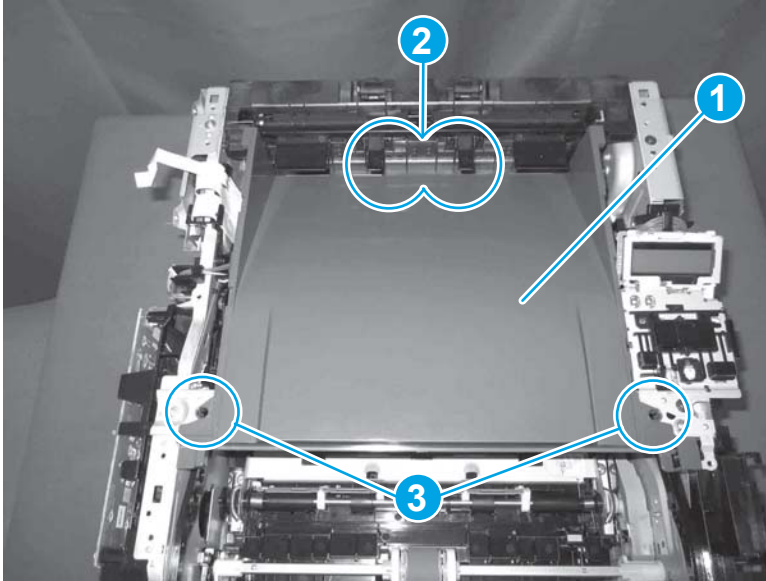

Step 16: Install the top cover (M403/M402)

 **NOTE:** The step is for the M403/M402 printer. For the M427/M426, skip this step and go to [Step 17: Install the top cover \(M427/M426\) on page 854](#).

1. Position the rear edge of the cover on the printer.

Figure 1-1600 Install the cover

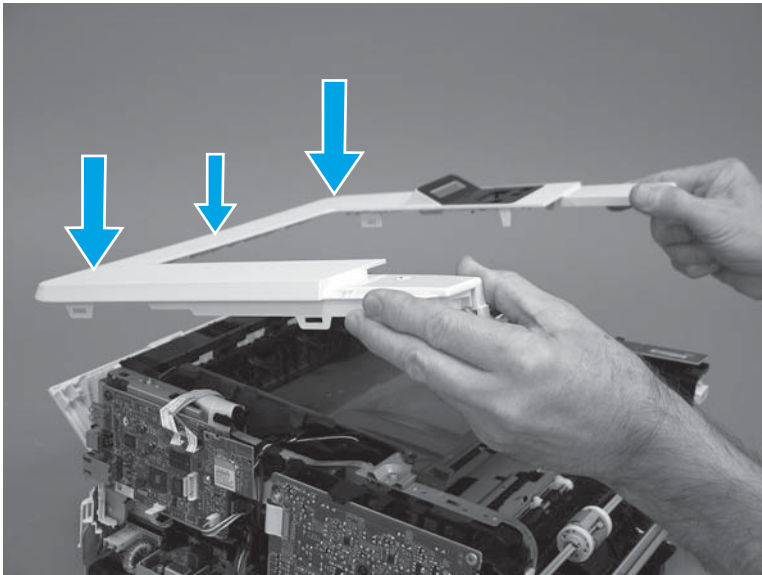

- Engage four bosses (callout 1), rotate the front of the cover down (callout 2) and onto from the printer, and then engage four tabs (callout 3).

Figure 1-1601 Engage four bosses and tabs

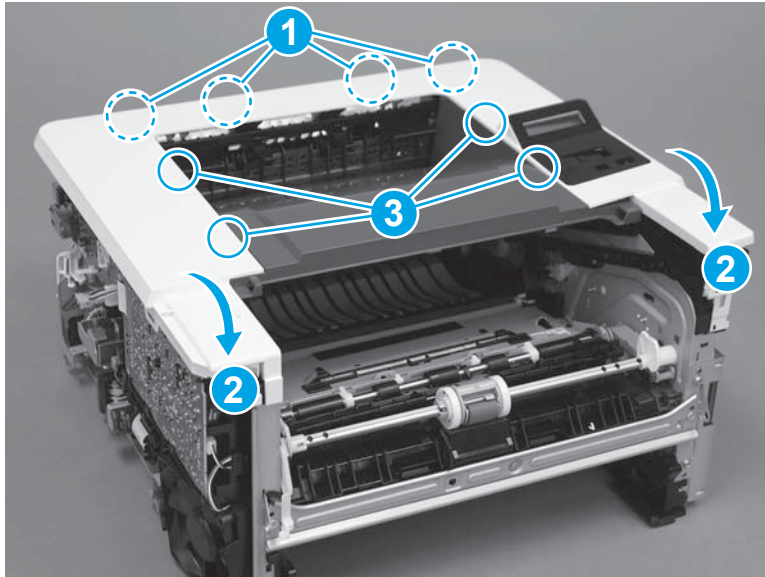

- At the right side of the printer, engage the one boss and one tab (callout 1).

Figure 1-1602 Engage one boss and one tab

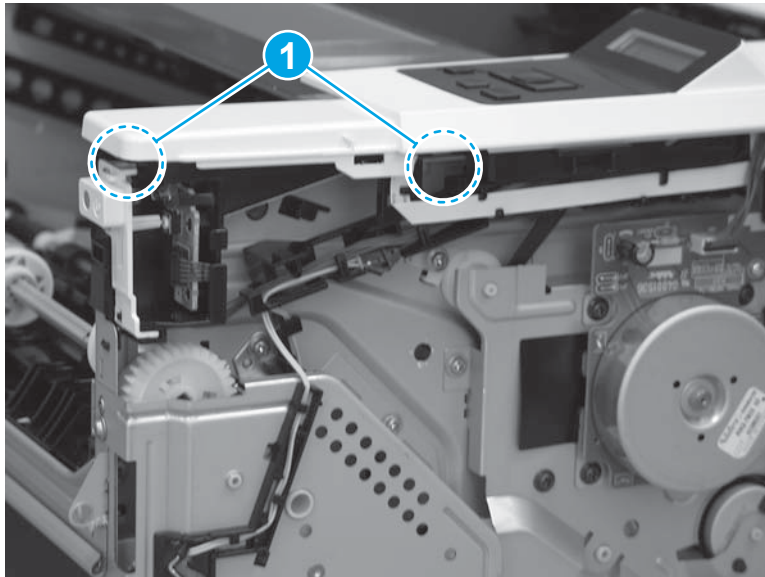

4. Install one screw (callout 1).

Figure 1-1603 Install one screw

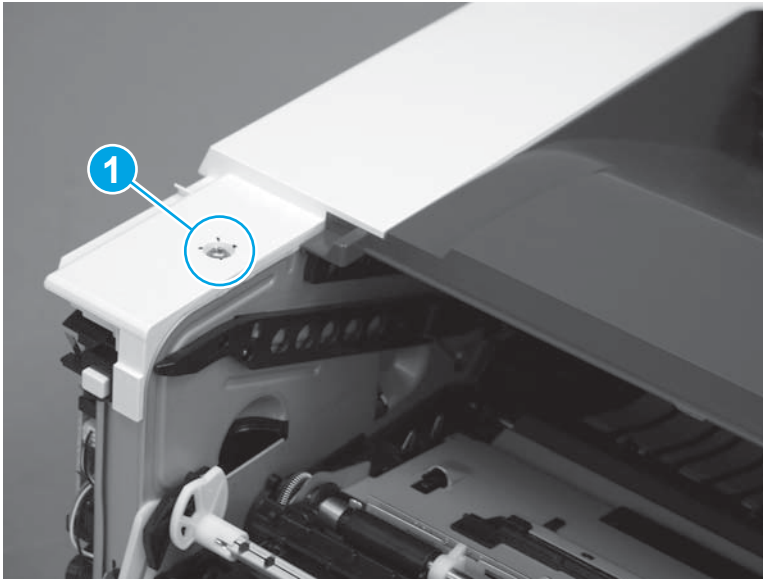

Step 17: Install the top cover (M427/M426)

 **NOTE:** The step is for the M427/M426 printer. For the M403/M402, skip this step and go to [Step 20: Install the right cover on page 865](#).

1. Position the rear edge of the top cover on the printer.

Figure 1-1604 Install the cover

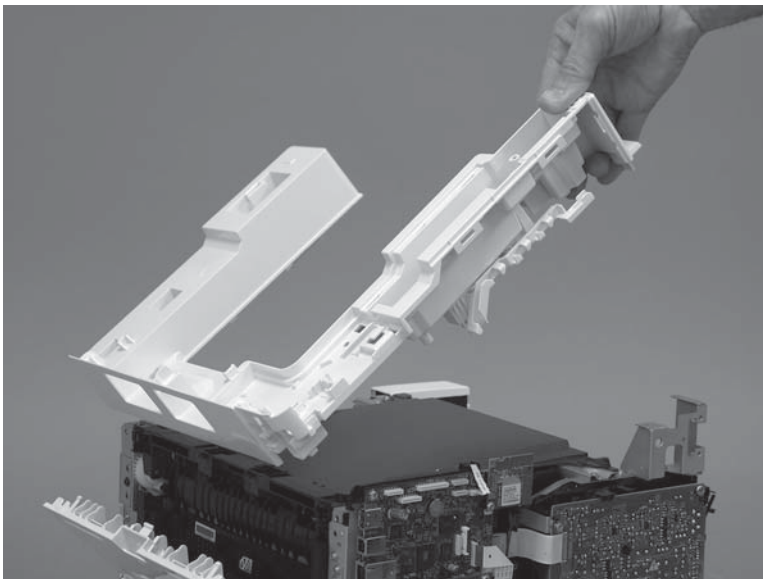

2. Engage four bosses (callout 1).

Figure 1-1605 Engage four bosses

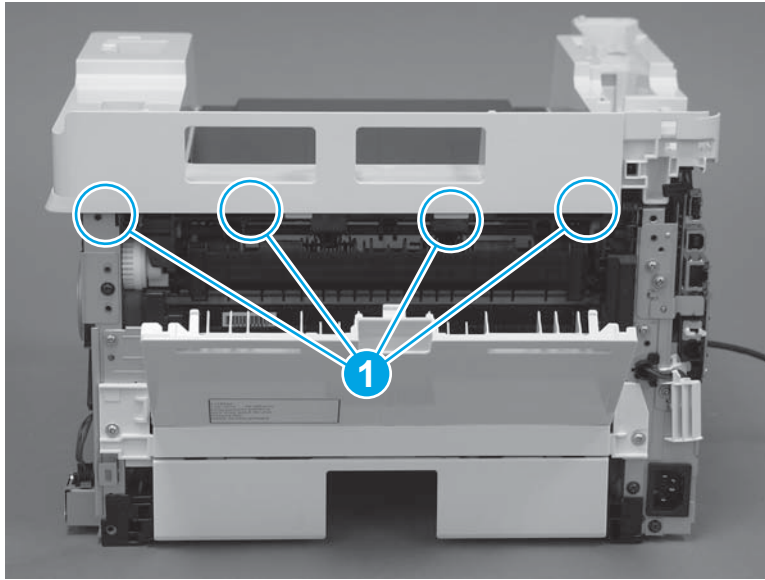

3. Rotate the front edge of the cover down.

Figure 1-1606 Rotate the front edge of the cover down

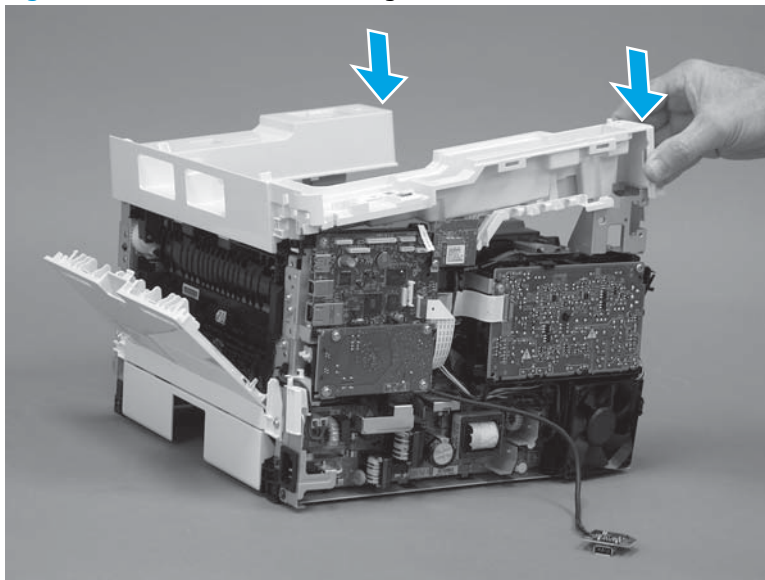

4. Install the USB cable (callout 1) in the guide.

Figure 1-1607 Install the USB PCA

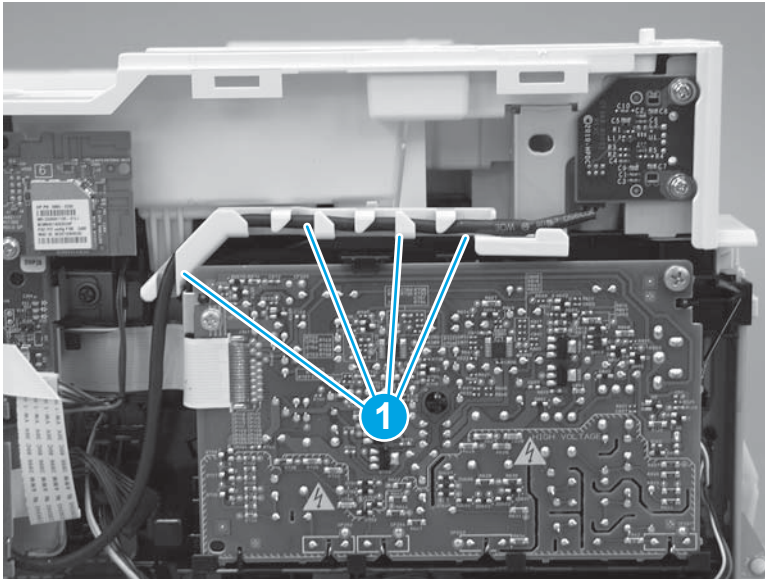

5. Install five screws (callout 1).

Figure 1-1608 Install five screws

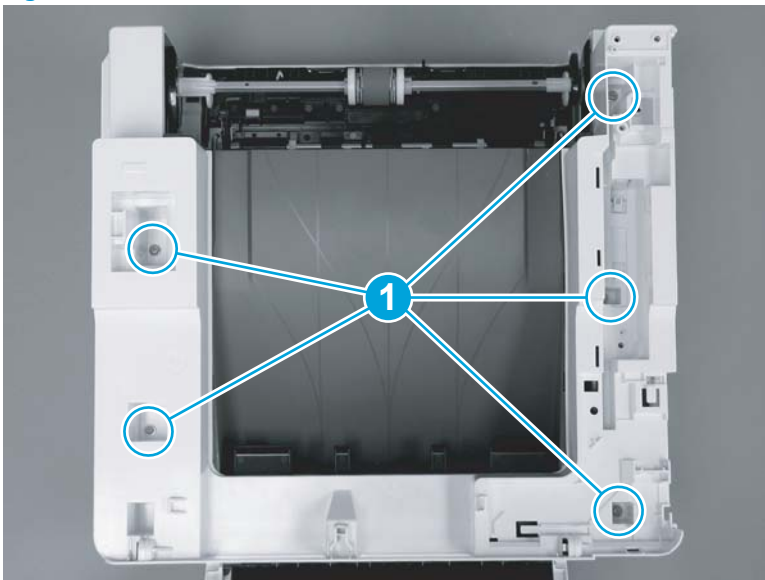

Step 18: Install the control panel (M427/M246)

 **NOTE:** The step is for the M427/M426 printer. For the M403/M402, skip this step and go to [Step 20: Install the right cover on page 865](#).

1. Slide the control-panel FFC cover into the slot in the top cover (next to the document feeder support arm) to install it.

Figure 1-1609 Install the control-panel FFC cover

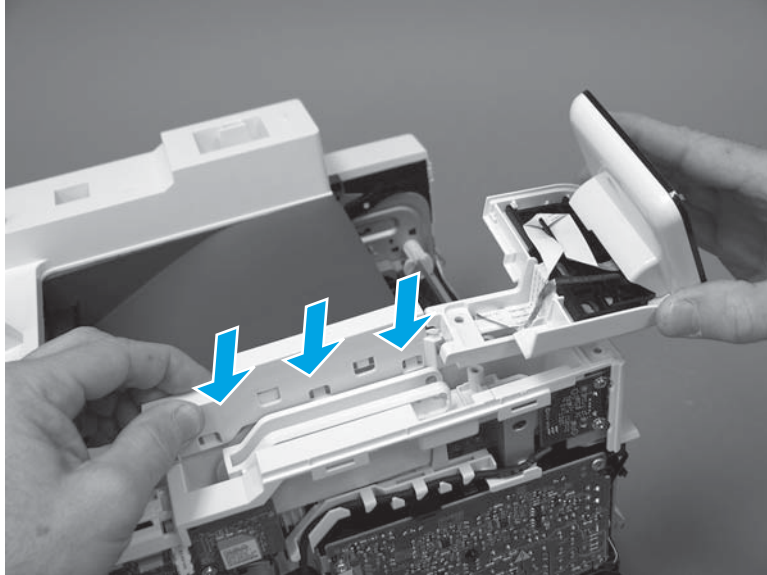

2. Install the control-panel assembly on the top cover.

Figure 1-1610 Install the control-panel assembly

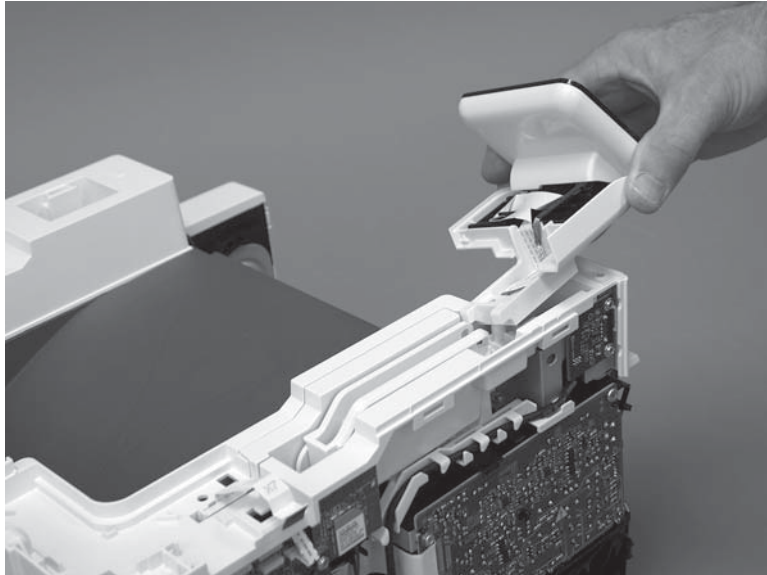

3. Move the FFC out of the way, and then install two screws (callout 1).

Figure 1-1611 Install two screws

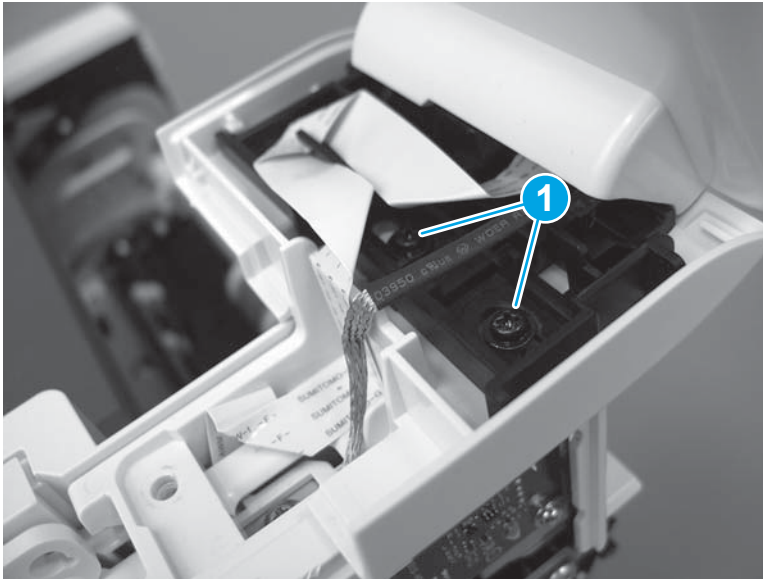

4. Install one grounding screw (callout 1), and then make sure that the ground cable (callout 2) is properly routed.

Figure 1-1612 Remove one screw

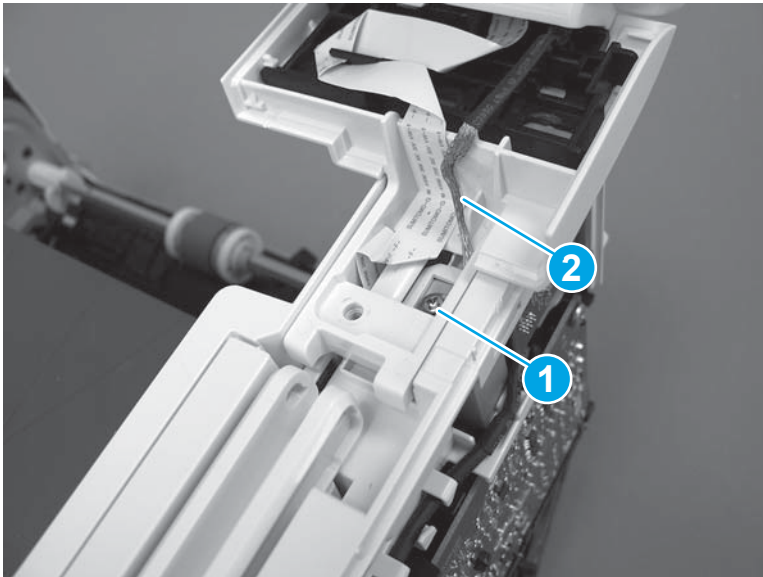

5. Install the control-panel cable cover.

Figure 1-1613 Install the cover

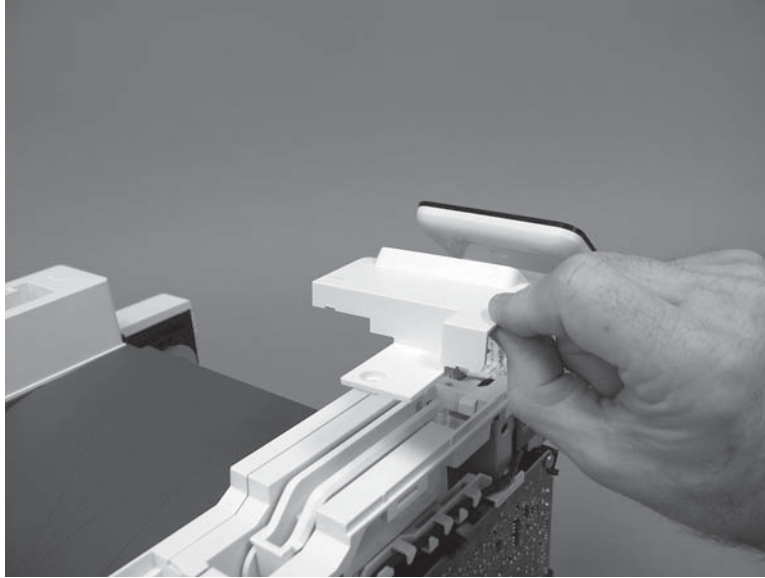

6. Make sure that the two tabs (callout 1) on the cover snap into place.

Figure 1-1614 Engage two tabs

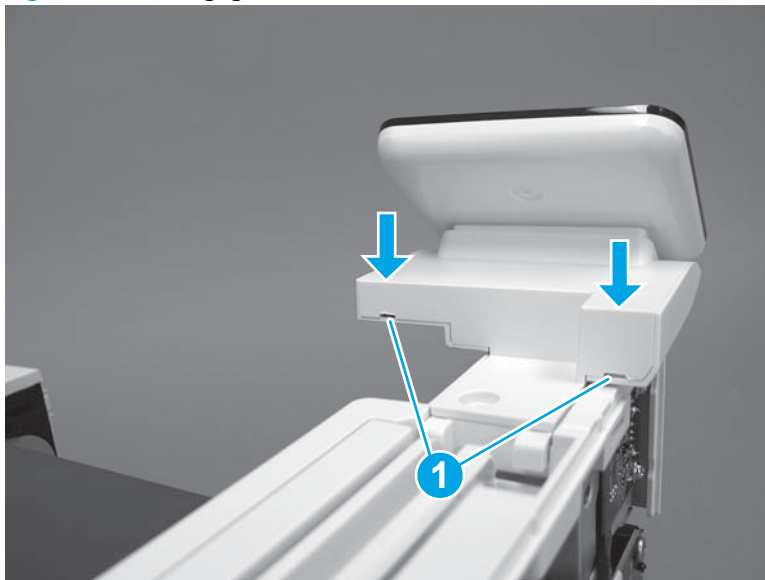

7. Install one screw (callout 1).

Figure 1-1615 Install one screw

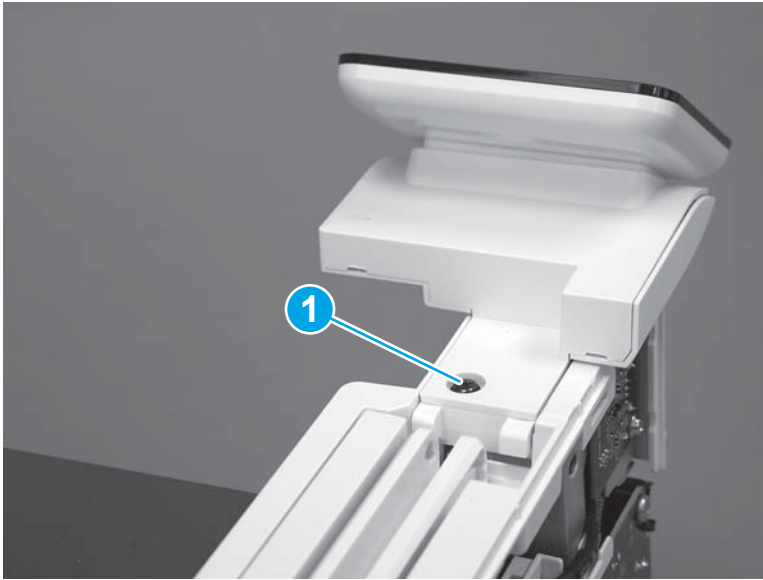

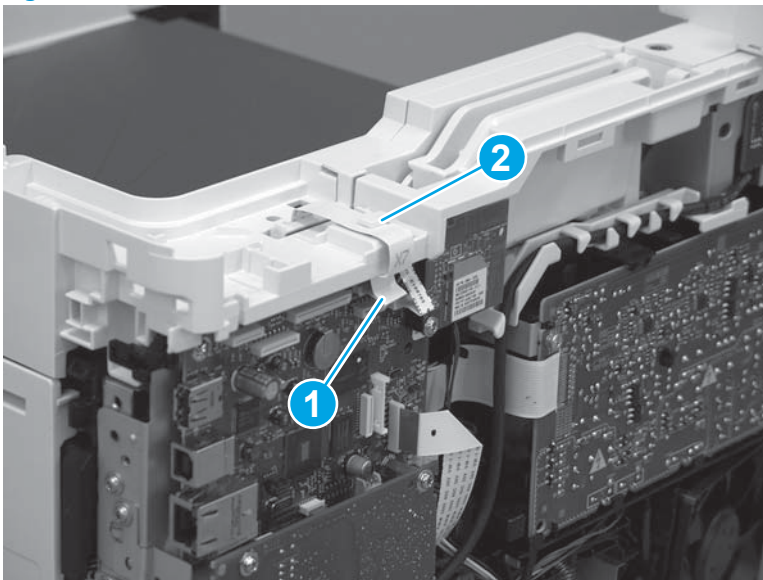

8. Install the FFC in the retainer (callout 1), and then connect one FFC (callout 1; J114).

Figure 1-1616 Connect one connector



Step 19: Install the integrated scanner assembly (M427/M246)

 **NOTE:** The step is for the M427/M426 printer. For the M403/M402, skip this step and go to [Step 20: Install the right cover on page 865](#).

 **NOTE:** M427/M426 models only. The integrated scanner assembly (ISA) includes the sub-scanner assembly (SSA) and the automatic document feeder (ADF).

1. Position the ISA on the printer.

Figure 1-1617 Position the ISA on the printer

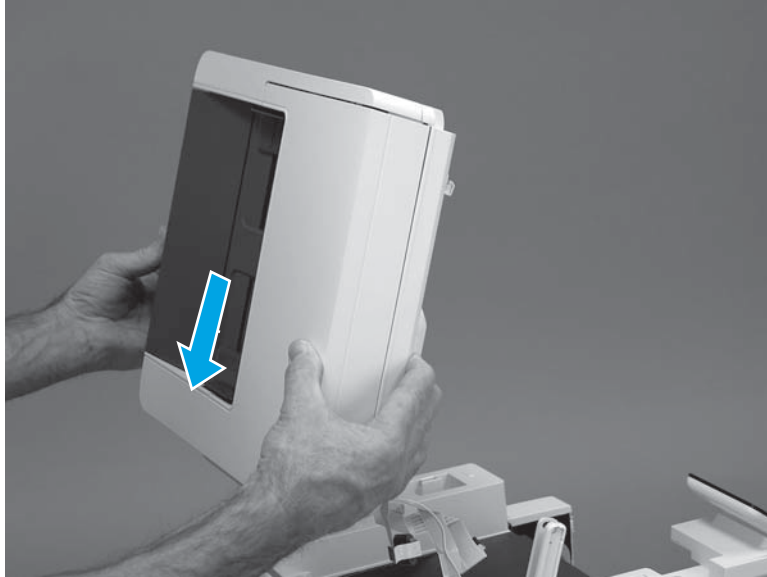

2. Engage the hinge pins on the ISA with the holders in the top cover (callouts 1/2), and then slide the ISA as shown to engage them

Figure 1-1618 Engage the hinge pins with the holders

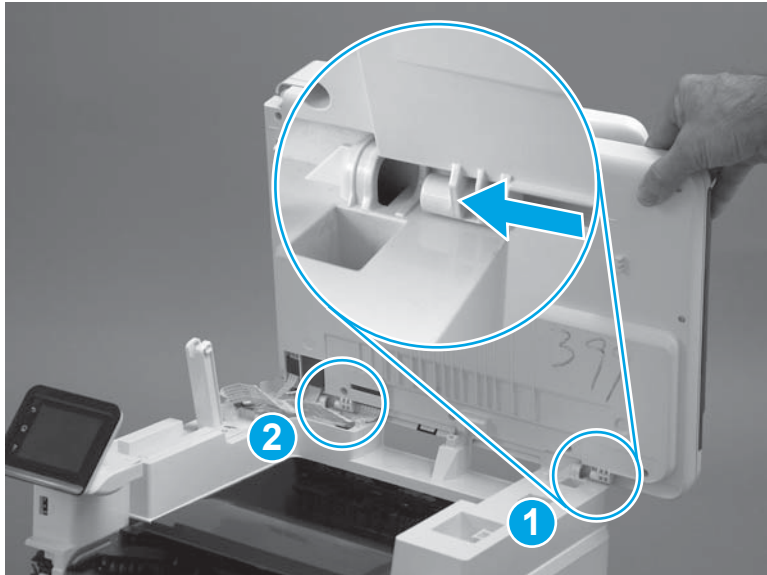

3. Rotate the ISA towards the front of the printer until it rests on the ISA lift assembly (callout 1).

Figure 1-1619 Rotate the ISA towards the front of the printer

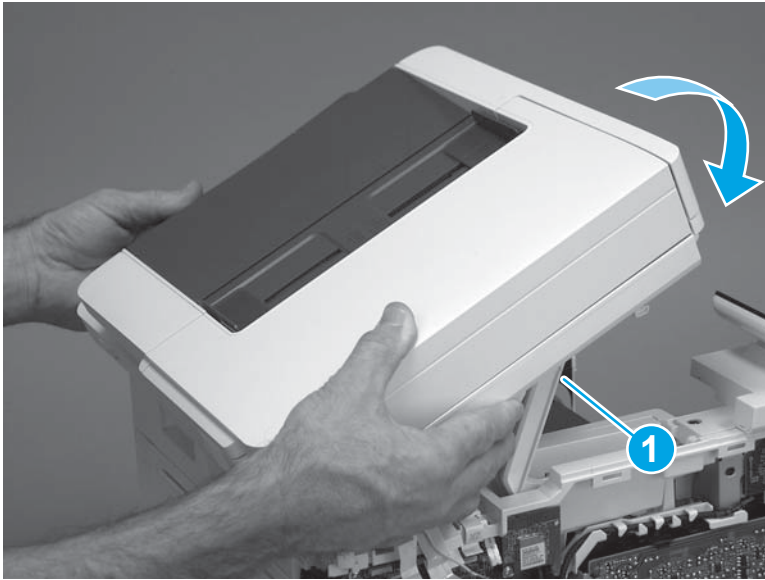

4. Pass the ground wire through the opening in the top cover.

Figure 1-1620 Pass the wire through the opening

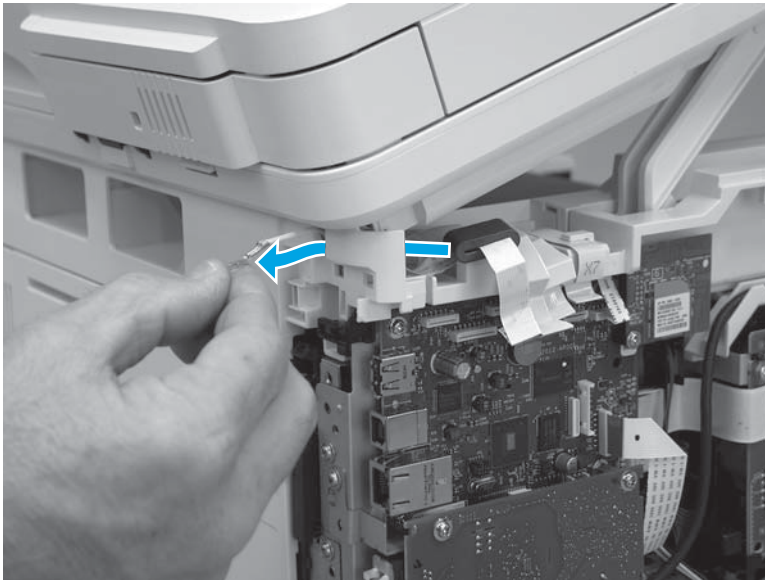

5. Install one screw (callout 1).

Figure 1-1621 Install one screw

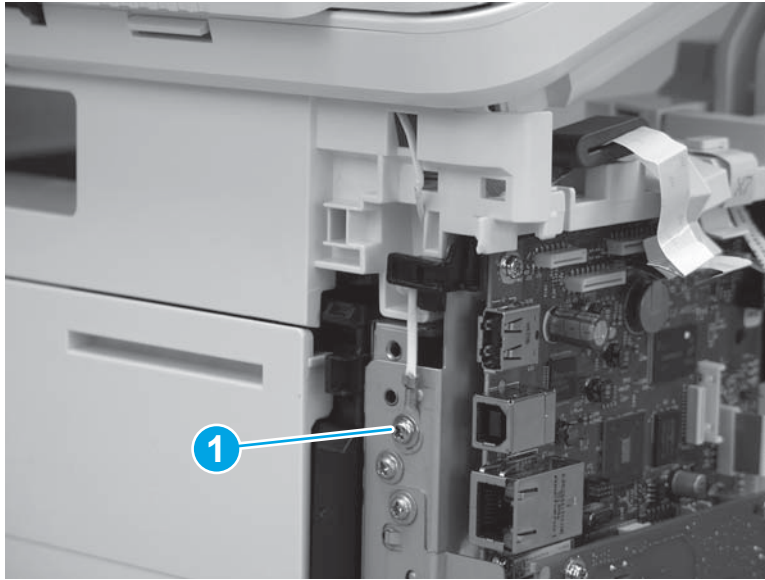

6. Install the ISA lift assembly slider pin.

 **Reinstallation tip:** Align the keyed portion of the locking pin with the slot and hole in the support arm.

Figure 1-1622 Install the slider pin



7. Rotate the slider pin (callout 1) towards the rear of the printer until the tab (callout 2) snap into place.

Figure 1-1623 Secure the slider pin

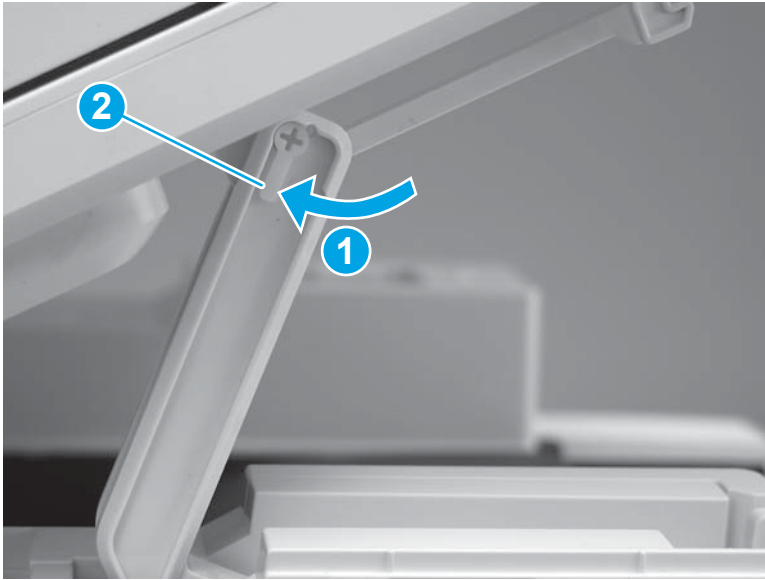

8. Install the ferrite (callout 1) in the holder, and then connect three FFCs (callout 2).

Figure 1-1624 Connect three FFCs

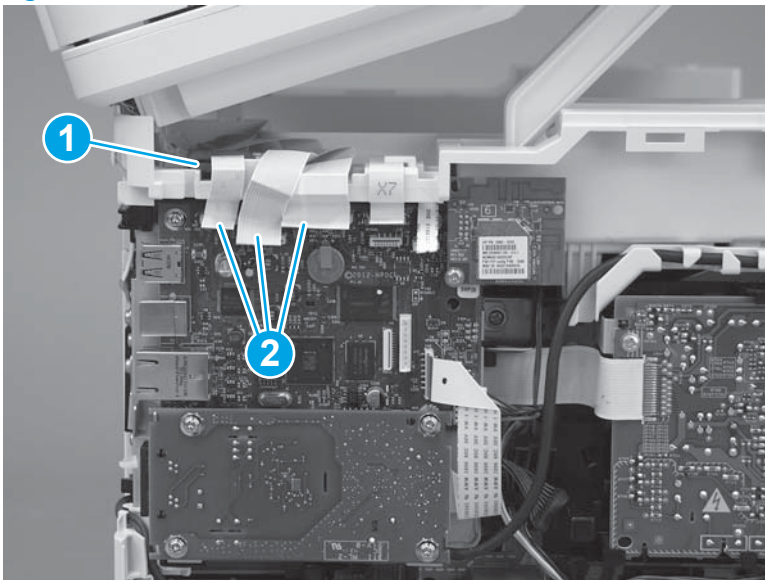

9. Position the rear edge of the ISA flat-flexible cable (FFC) cover on the printer (callout 1) , and then rotate it down (callout 2) until it snaps into place.

Figure 1-1625 Install the ISA FFC cover

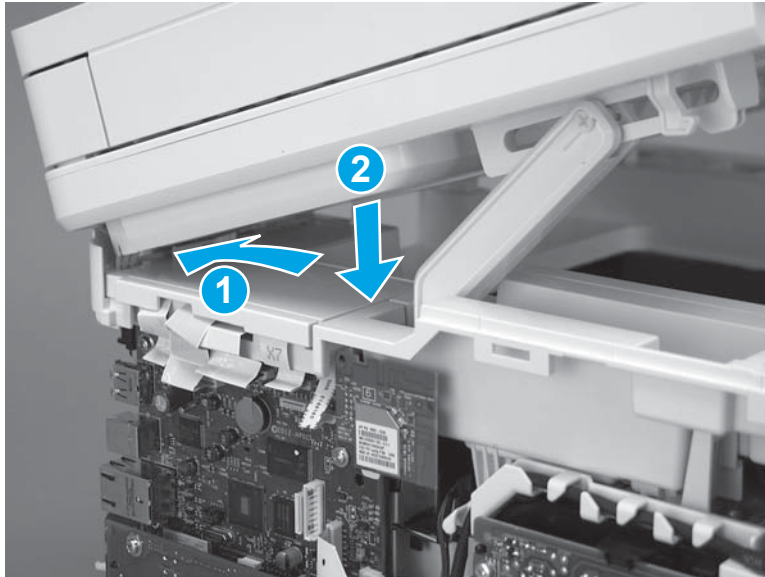

10. Lower the ISA.

Figure 1-1626 Lower the ISA

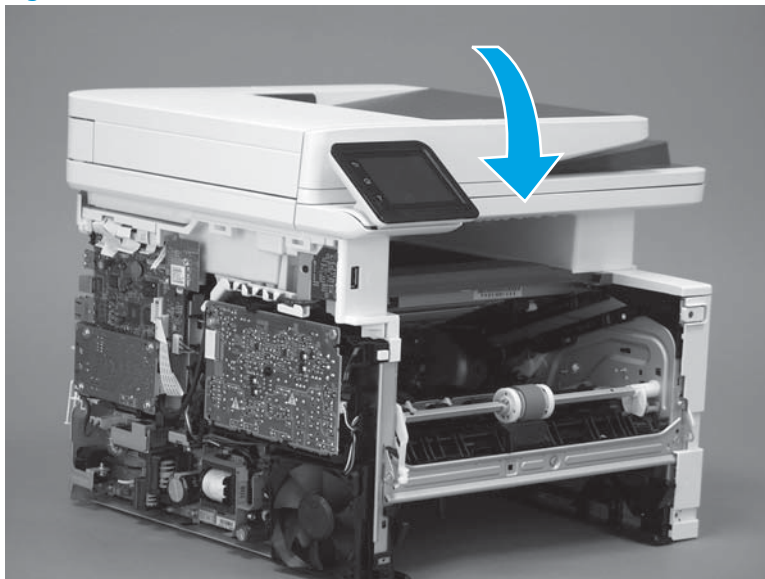

Step 20: Install the right cover

1. Position the cover (callout 1) on the printer, and then engage two bosses (callout 2).

Figure 1-1627 Install the cover

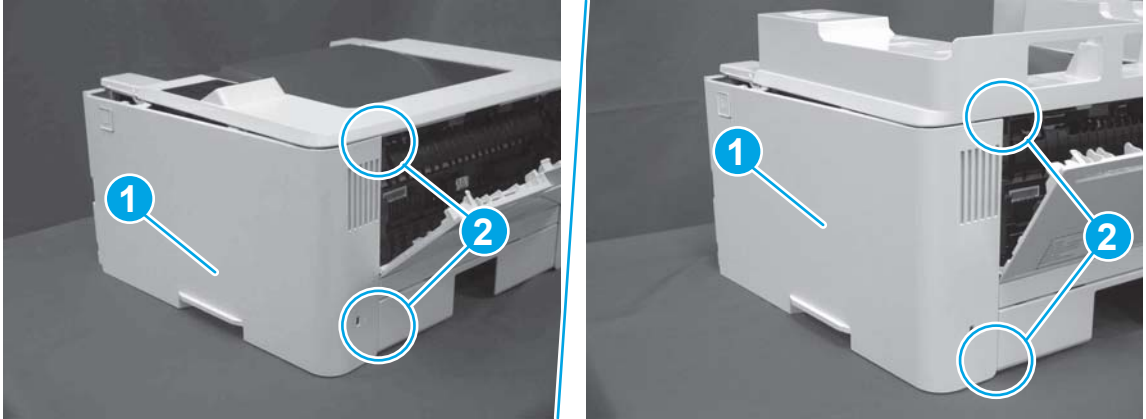

2. Rotate the front of the cover onto the printer (callout 1), engage three (callout 2) tabs, and then engage two bosses (callout 3).

Figure 1-1628 Engage two bosses and one tab

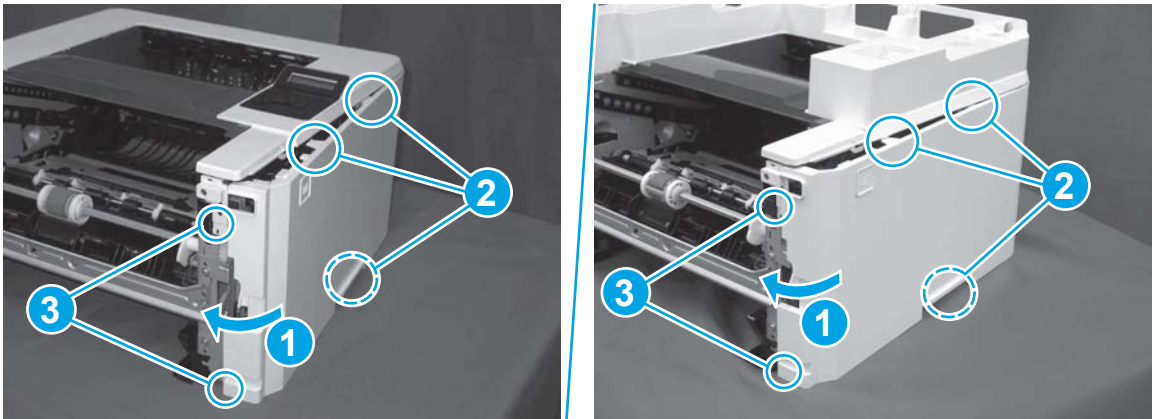

3. Make sure that the power switch (callout 1) and cartridge door assembly button (callout 2) correctly function.

 **NOTE:** Remove, and then reinstall the cover if the switch or button does not correctly function.

Figure 1-1629 Check the power switch and cartridge door assembly button



4. Install one screw (callout 1).

Figure 1-1630 Install one screw

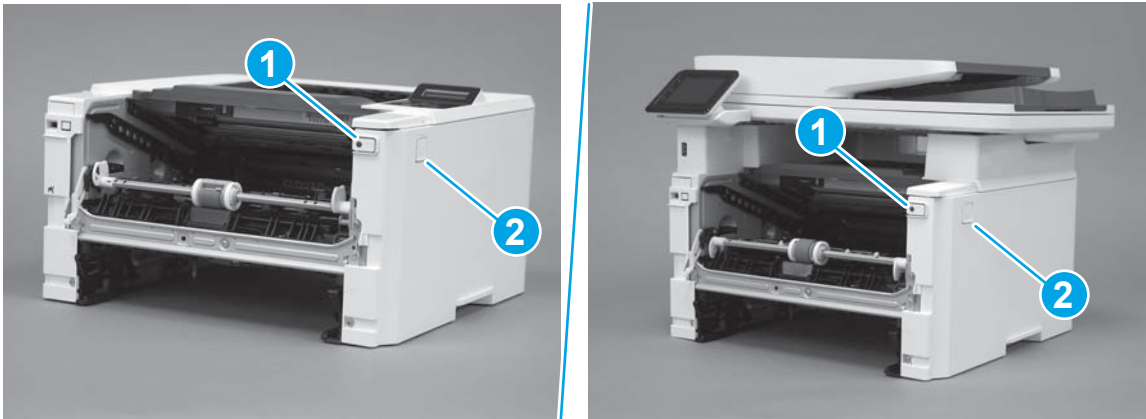

Step 21: Install the left cover

1. At the front of the printer, do one of the following:
 - **M403/M402:** Position the cover on the printer (callout 1), and then engage two bosses (callout 2).
 - **M427/M426:** Position the cover on the printer (callout 3), engage one tab (callout 4), and then engage two bosses (callout 4).

Figure 1-1631 Install the cover

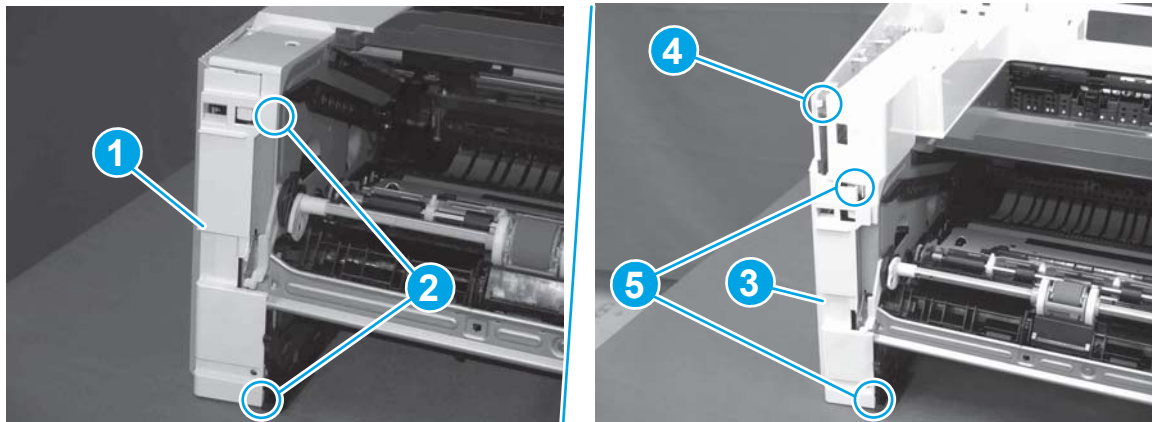

- Carefully rotate the rear of the cover onto the printer (callout 1), engage three tabs (callout 2), and then engage two bosses (callout 3).

Figure 1-1632 Engage three tabs and two bosses

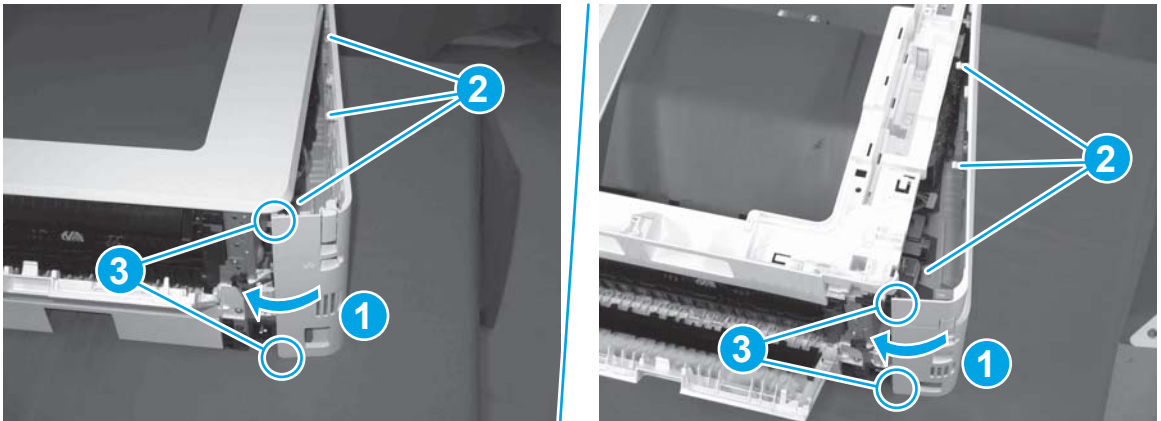

- Install one screw (callout 1).

Figure 1-1633 Install one screw

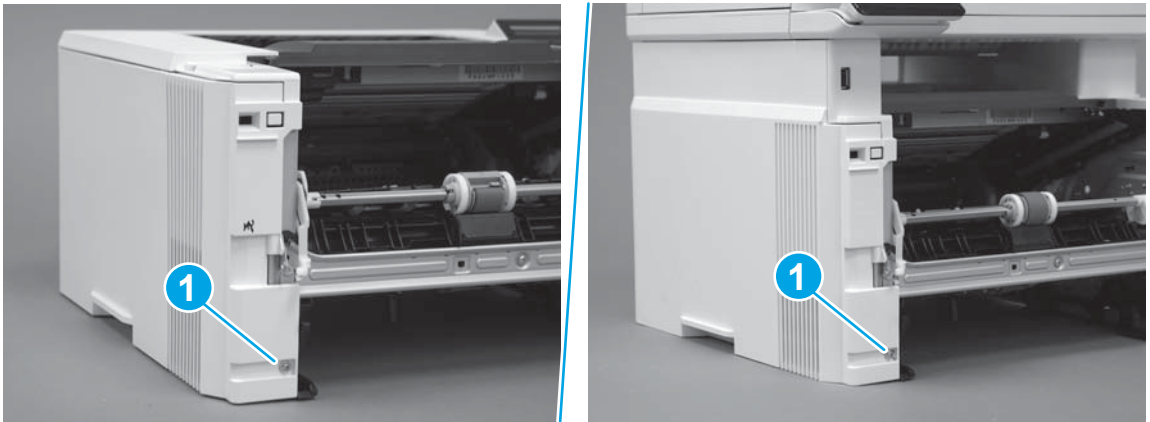

Step 22: Install the cartridge door assembly

 **Reinstallation tip:** After a replacement door is installed, make sure to install the nameplate (supplied in the kit) corresponding to the printer name on the door.

- Position the door close to the printer, and then engage the keyed pin on the left-side retainer arm with the hole in the door.

Figure 1-1634 Engage the left-side retainer arm

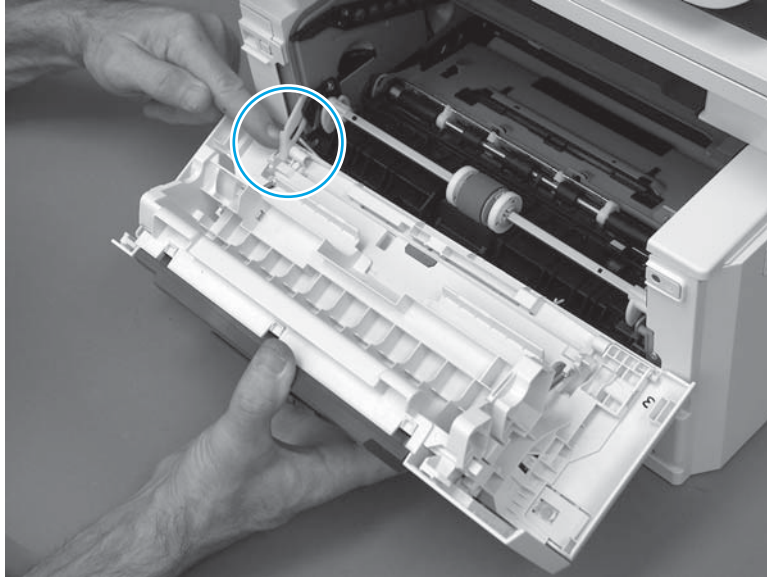

2. Engage the right-side door hinge pin with the hole in the chassis (callout 1).

Figure 1-1635 Install the door

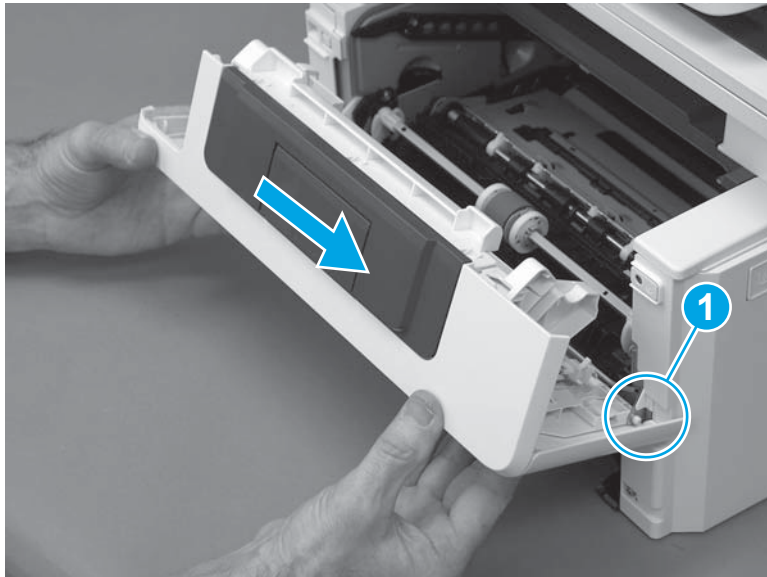

3. Install the link (callout 1).

 **IMPORTANT:** Make sure that the link snaps into place on the arm (callout 2). The link actuates the fuser pressure-release mechanism.

Figure 1-1636 Install the pressure-release link

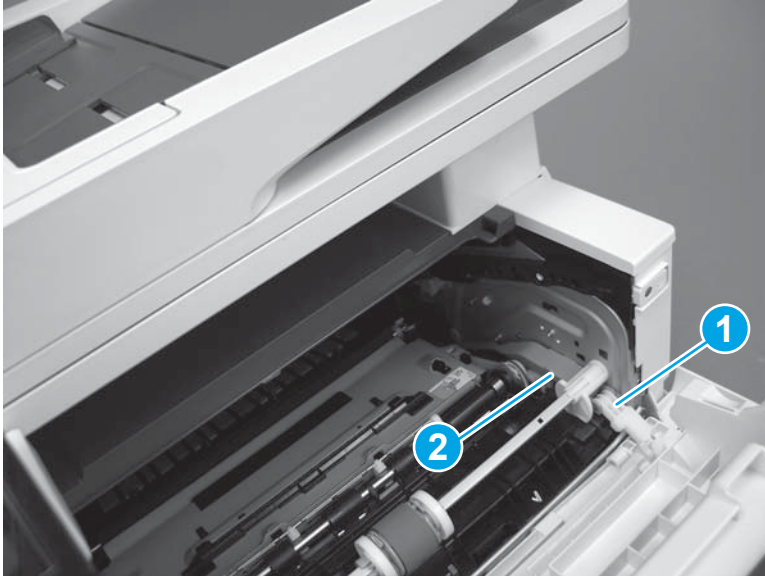

4. Slide the guide into the printer (callout 1), and then make sure that the tab (callout 2) snaps into place to secure the guide to the chassis.

Figure 1-1637 Install the guide

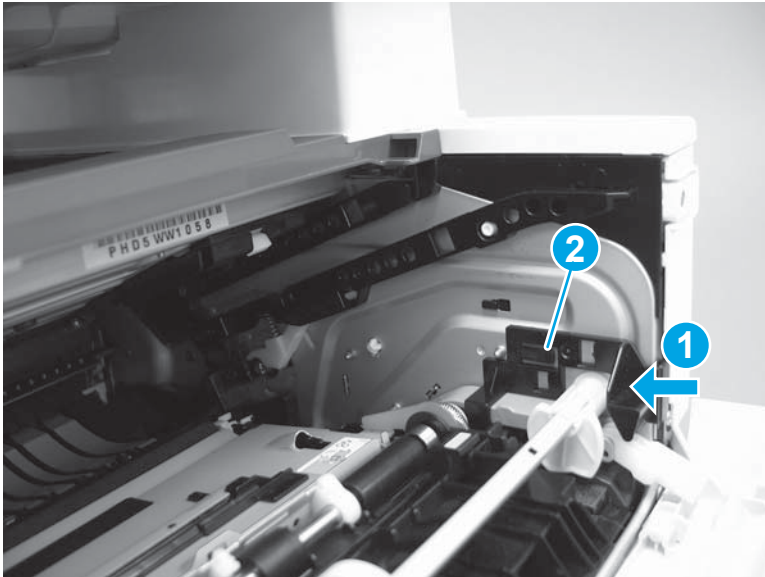

5. Position the shaft on the door, and then align the left-side hinge on the door with the hole in the chassis (callout 1).

Figure 1-1638 Align the hinge

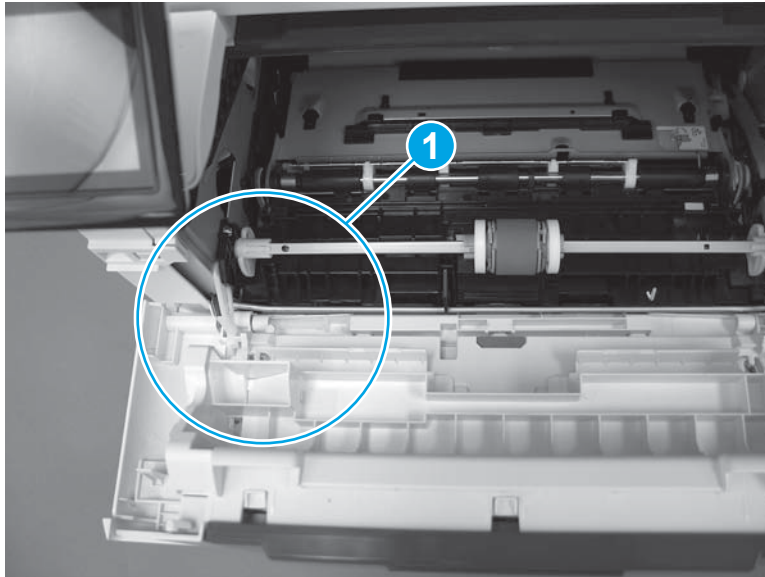

6. Push the shaft towards the left side of the printer to install it (callout 1).

 **Reinstallation tip:** Make sure that the support shaft is fully installed and correctly orientated (callout 2) so that it will not interfere with the door opening and closing.

Figure 1-1639 Install the support shaft



Step 23: Install Tray 2

- ▲ Slide the tray straight into the printer to install it.

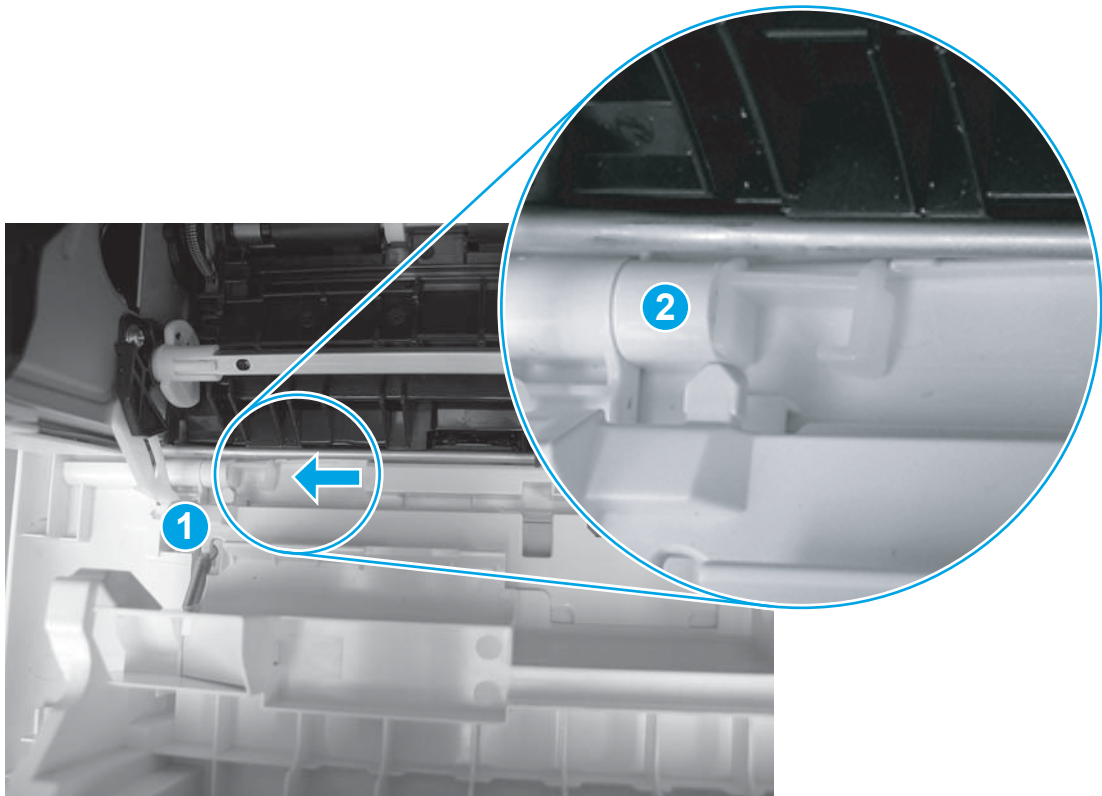
Figure 1-1640 Install the tray



Removal and replacement: Laser scanner FFC

- [Introduction](#)
- [Step 1: Remove Tray 2](#)
- [Step 2: Remove the cartridge door assembly](#)
- [Step 3: Remove the left cover](#)
- [Step 4: Remove the right cover](#)
- [Step 5: Remove the integrated scanner assembly \(M427/M246\)](#)
- [Step 6: Remove the control panel \(M427/M246\)](#)
- [Step 7: Remove the top cover \(M427/M426\)](#)
- [Step 8: Remove the top cover \(M403/M402\)](#)
- [Step 9: Remove the paper delivery tray \(output bin\)](#)
- [Step 10: Remove the sheet-metal formatter bracket and formatter PCA](#)
- [Step 11: Remove the tag-cable assembly](#)
- [Step 12: Remove the laser scanner FFC](#)
- [Step 13: Unpack the replacement assembly](#)
- [Step 14: Install the laser scanner FFC](#)
- [Step 15: Install the tag-cable assembly](#)
- [Step 16: Install the sheet-metal formatter bracket and formatter PCA](#)
- [Step 17: Install the paper delivery tray \(output bin\)](#)
- [Step 18: Install the top cover \(M403/M402\)](#)
- [Step 19: Install the top cover \(M427/M426\)](#)
- [Step 20: Install the control panel \(M427/M246\)](#)
- [Step 21: Install the integrated scanner assembly \(M427/M246\)](#)
- [Step 22: Install the right cover](#)
- [Step 23: Install the left cover](#)
- [Step 24: Install the cartridge door assembly](#)
- [Step 25: Install Tray 2](#)

Introduction

This document provides the procedures to remove and replace the laser scanner flat-flexible cable (FFC).

Before performing service

Turn the printer power off

- Disconnect the power cable.

 **WARNING!** To avoid damage to the printer, turn the printer off, wait 30 seconds, and then remove the power cable before attempting to service the printer.

Use the table below to identify the correct part number for your printer. To order the part, go to www.hp.com/buy/parts.

Laser scanner FFC part number	
RK2-6919-000CN	Laser scanner FFC

Required tools

- #2 Phillips screwdriver with a magnetic tip.
- 5.5 mm (0.22 inch) socket screwdriver.

After performing service

Turn the printer power on

- Connect the power cable.
- Use the power switch to turn the power on.

Post service test

Make sure that the printer initializes to a **Ready** state.

Print a configuration page to make sure that the printer is functioning correctly.

Step 1: Remove Tray 2

- ▲ Pull the tray straight out of the printer to remove it.

Figure 1-1641 Remove the tray



Step 2: Remove the cartridge door assembly

 **NOTE:** If the toner cartridge was not removed prior to servicing the printer, remove it now.

1. Release one tab (callout 1), and then slide shaft (callout 2) in the direction the arrow indicates and remove it.

 **TIP:** It might be easier to release the support shaft by using a small flat-blade screwdriver.

Figure 1-1642 Release the support shaft

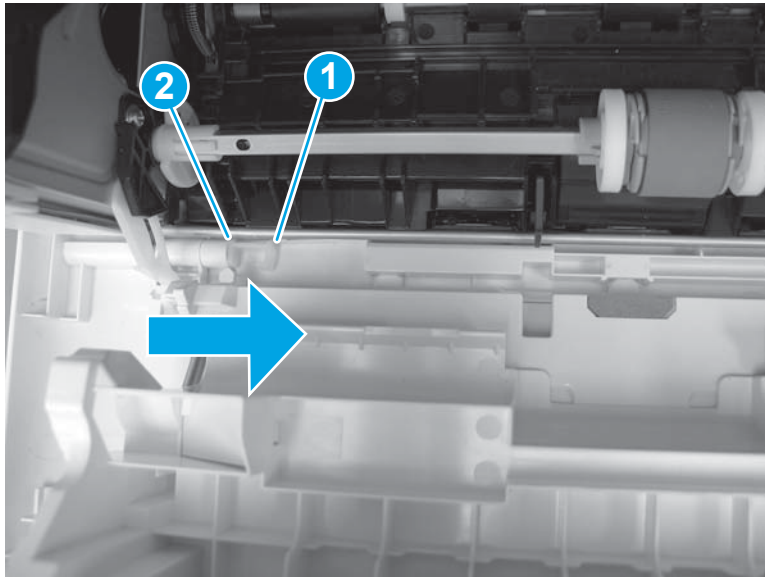

2. Release one tab (callout 1), and then slide the guide (callout 2) in the direction the arrow indicates and remove it.

Figure 1-1643 Remove the guide

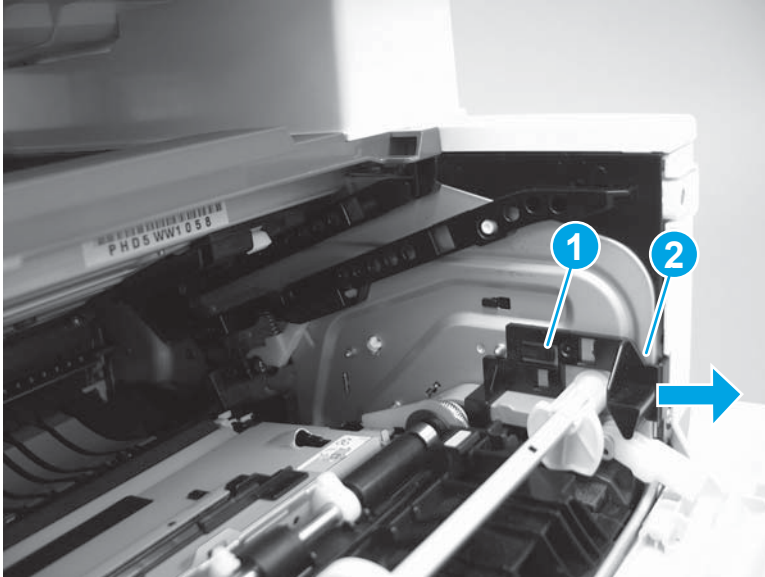

3. Remove the link arm (callout 1).

Figure 1-1644 Remove the link arm

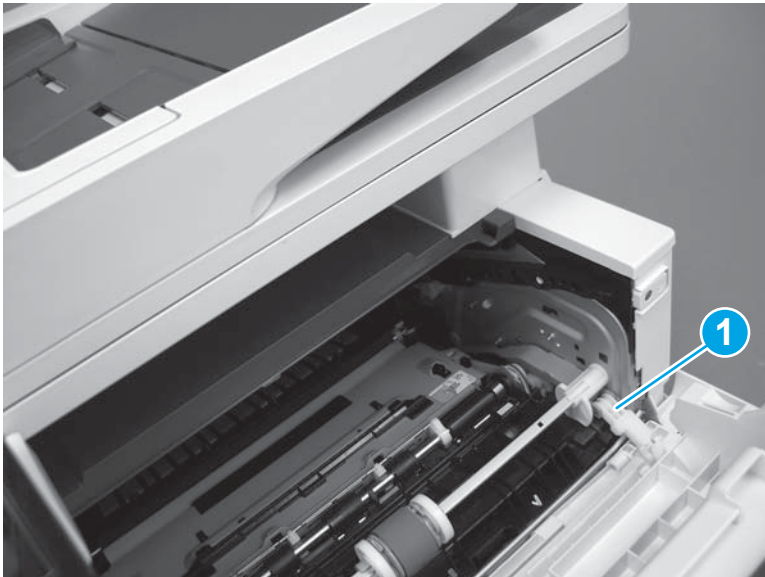

4. Slide the cartridge door assembly (callout 1) in the direction the arrow indicates and remove it.

Figure 1-1645 Remove the door

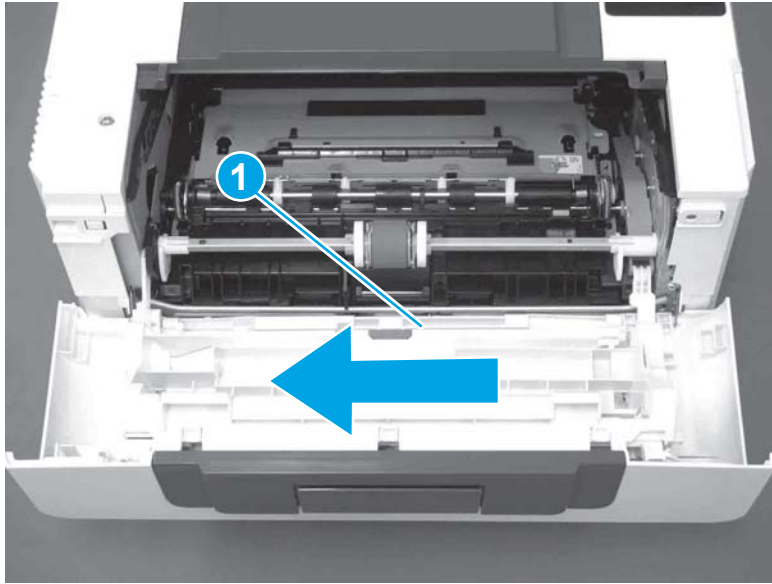

5. Remove the link (callout 1) from the cartridge door assembly (callout 2).

Figure 1-1646 Release the left-side retainer arm

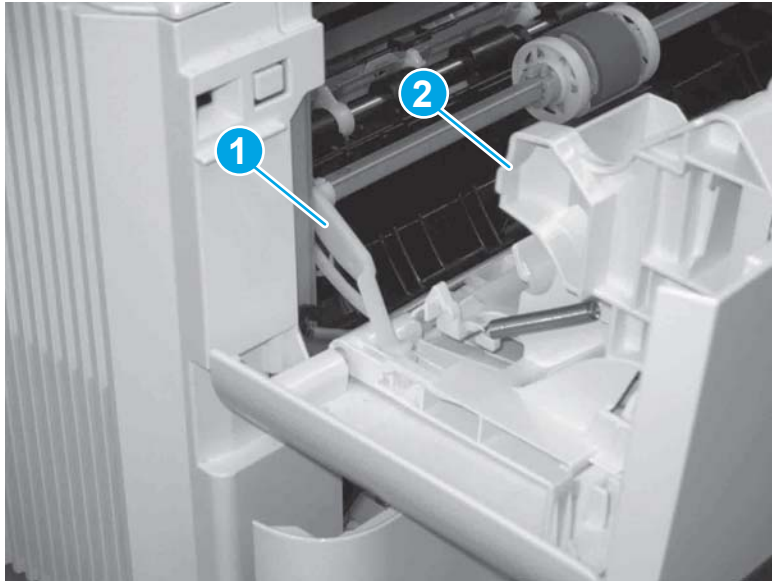

Step 3: Remove the left cover

1. Remove one screw (callout 1).

Figure 1-1647 Remove one screw



2. Open the rear door, release two bosses (callout 1), and then release three tabs (callout 2).

Figure 1-1648 Release two bosses and three tabs

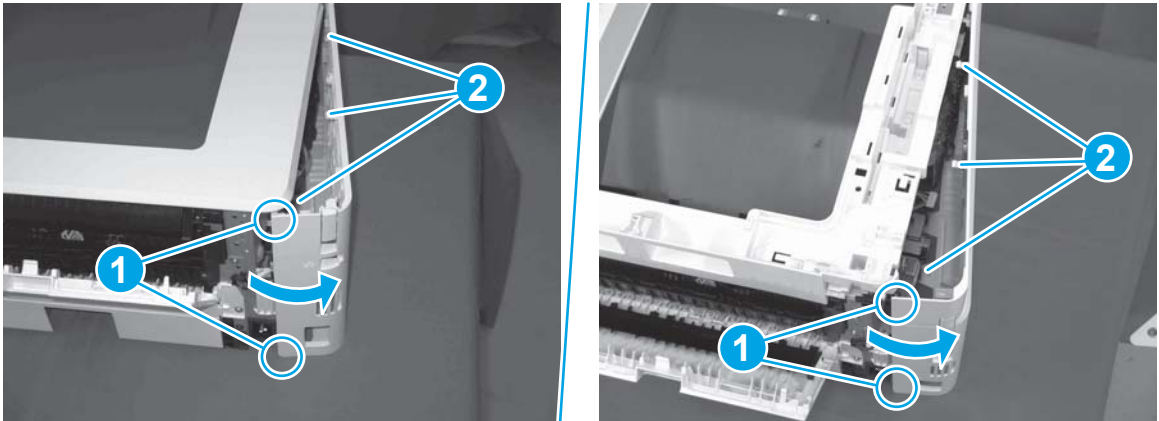

3. At the front of the printer, do one of the following:
 - **M403/M402:** Release two bosses (callout 1), and then remove the cover (callout 2).
 - **M427/M426:** Release one tab (callout 3), two bosses (callout 4), and then remove the cover (callout 5).

CAUTION: Be careful when releasing the upper bosses on the M427/M426 cover. One portion of the cover (callout 6) is fragile and is easily broken.

Figure 1-1649 Remove the cover

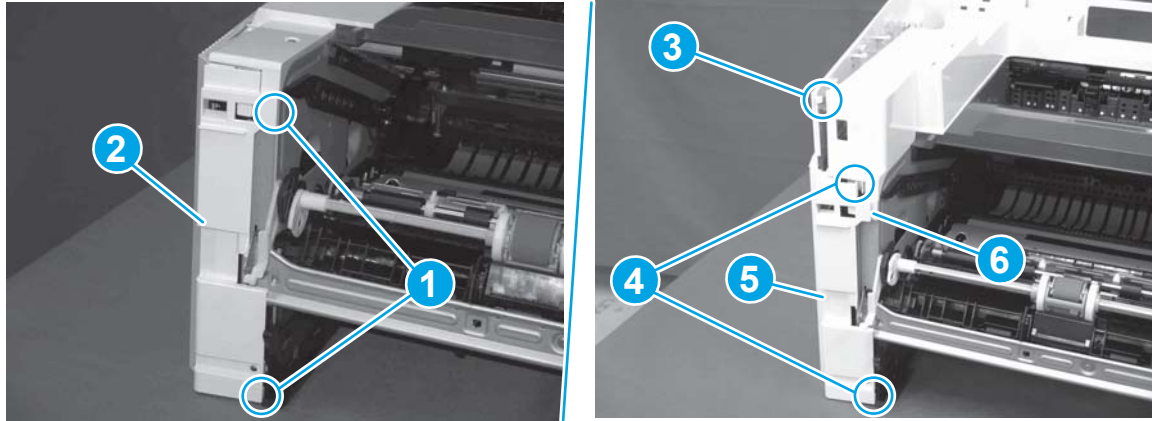

Step 4: Remove the right cover

1. Remove one screw (callout 1).

Figure 1-1650 Remove one screw



2. At the front of the printer, release two bosses (callout 1), and then release three tabs (callout 2).

Figure 1-1651 Release two bosses and three tabs

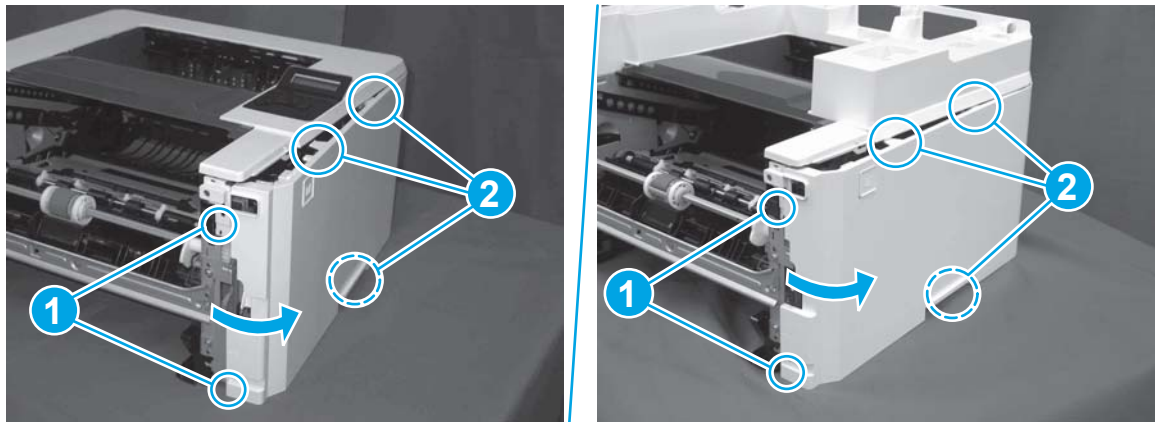

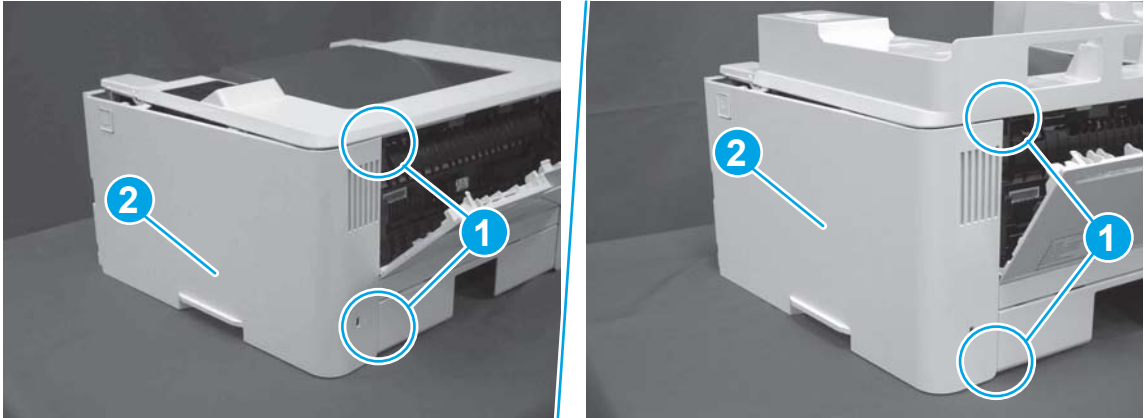

3. Open the rear door, release two bosses (callout 1), and then remove the cover (callout 2).

Figure 1-1652 Remove the cover



Step 5: Remove the integrated scanner assembly (M427/M246)

 **NOTE:** The step is for the M427/M426 printer. For the M403/M402, skip this step and go to [Step 8: Remove the top cover \(M403/M402\)](#) on page 890.

 **NOTE:** M427/M426 models only. The integrated scanner assembly (ISA) includes the sub-scanner assembly (SSA) and the automatic document feeder (ADF).

1. Raise the ISA.

Figure 1-1653 Raise the ISA

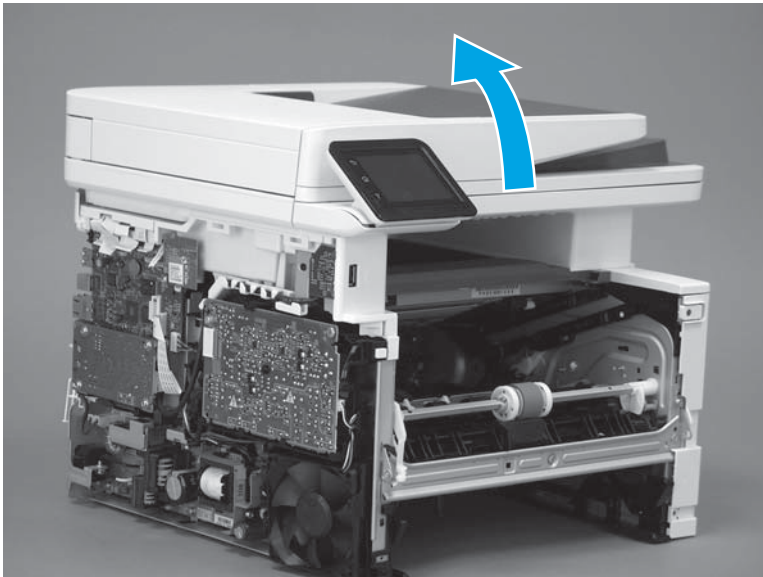

2. Release the ISA flat-flexible cable (FFC) cover (callout 1), and then remove it (callout 2).

Figure 1-1654 Remove the ISA FFC cover

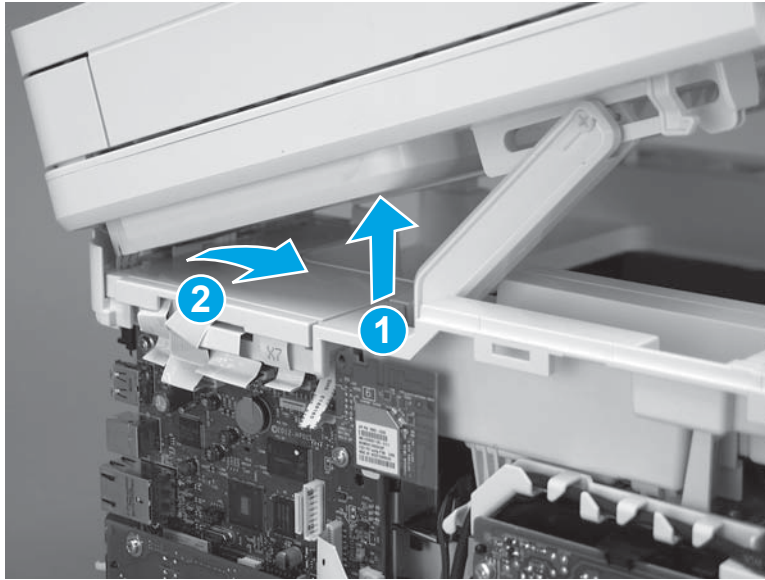

3. Disconnect three FFCs (callout 1), and then remove the ferrite (callout 2) from the holder.

CAUTION: The ferrite is not captive on the FFC. Do not lose the ferrite while handling the ISA.

Figure 1-1655 Disconnect three FFCs

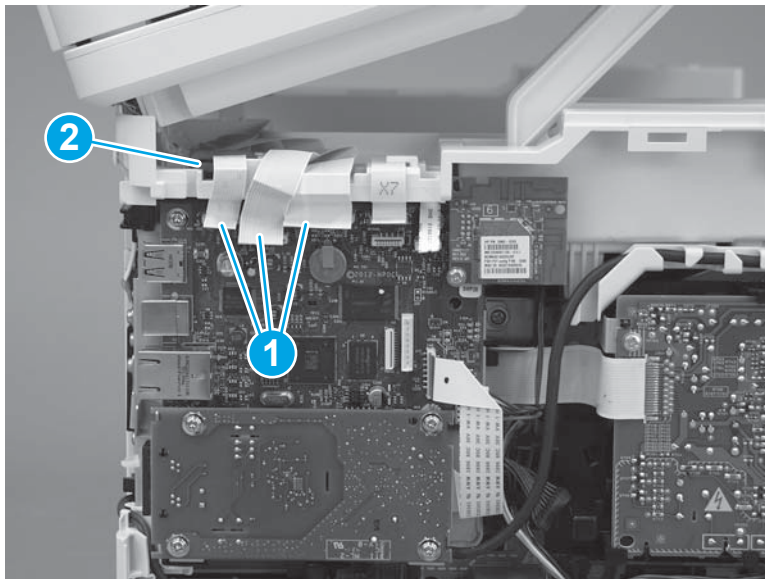

4. Remove one screw (callout 1).

Figure 1-1656 Remove one screw

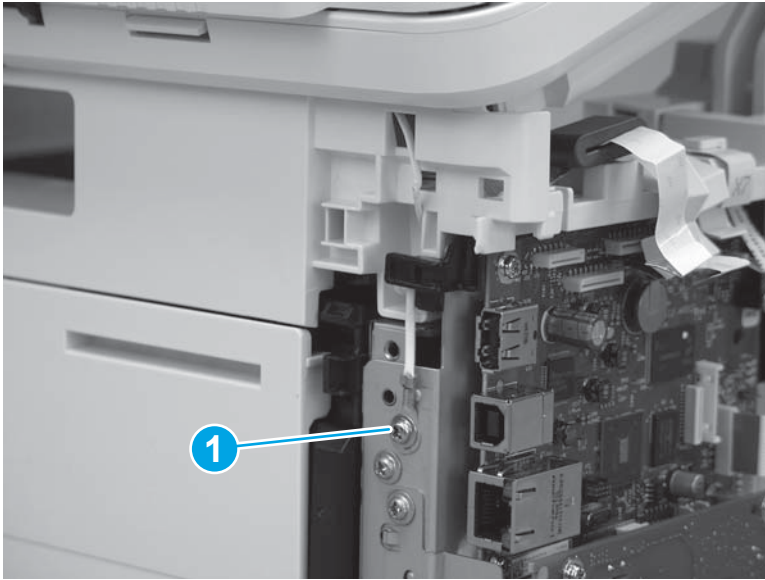

5. Pass the ground wire through the opening in the top cover.

Figure 1-1657 Pass the wire through the opening

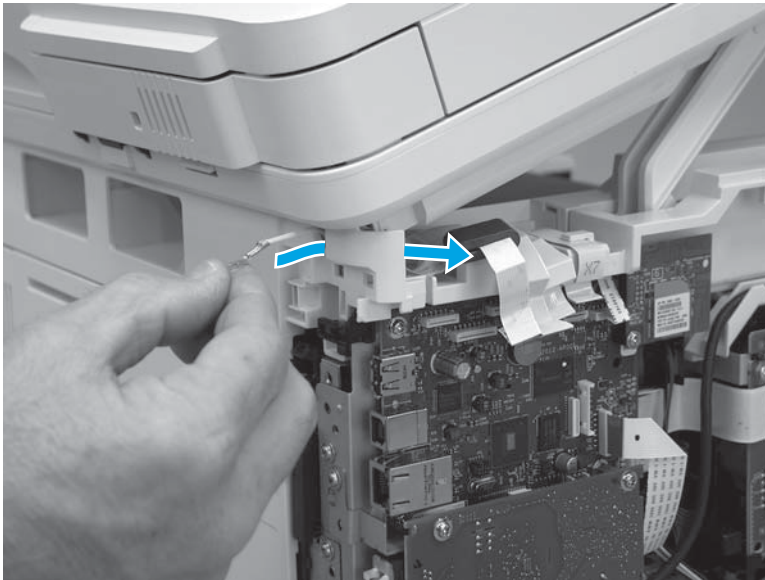

6. Release one tab (callout 1), and then rotate the ISA slider pin (callout 2) towards the front of the printer to release it.

Figure 1-1658 Release one tab and rotate the slider pin

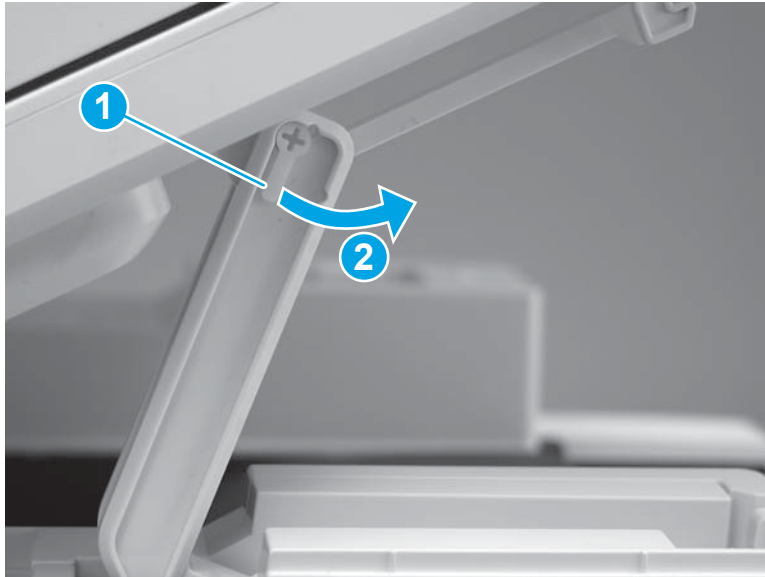

7. Remove the slider pin.

Figure 1-1659 Remove the slider pin

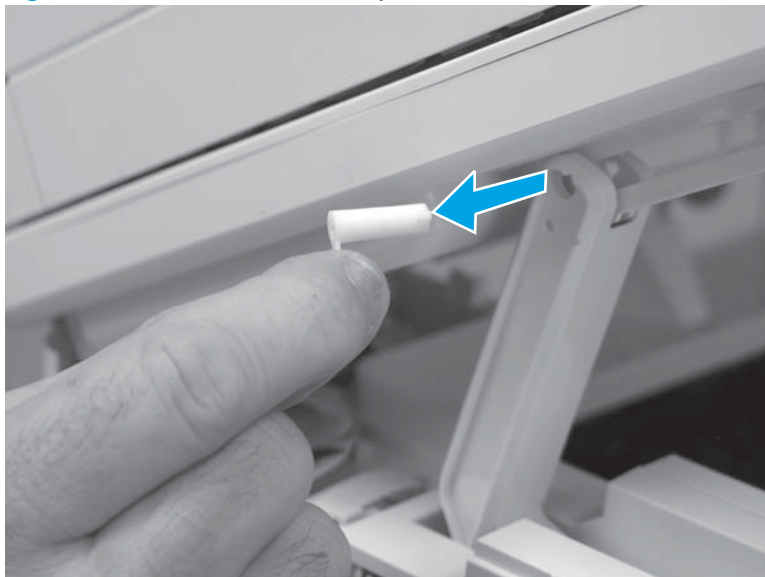

8. Rotate the ISA towards the rear of the printer until it stops.

Figure 1-1660 Rotate the ISA towards the rear of the printer



9. Slide the ISA as shown to release it.

Figure 1-1661 Release the ISA

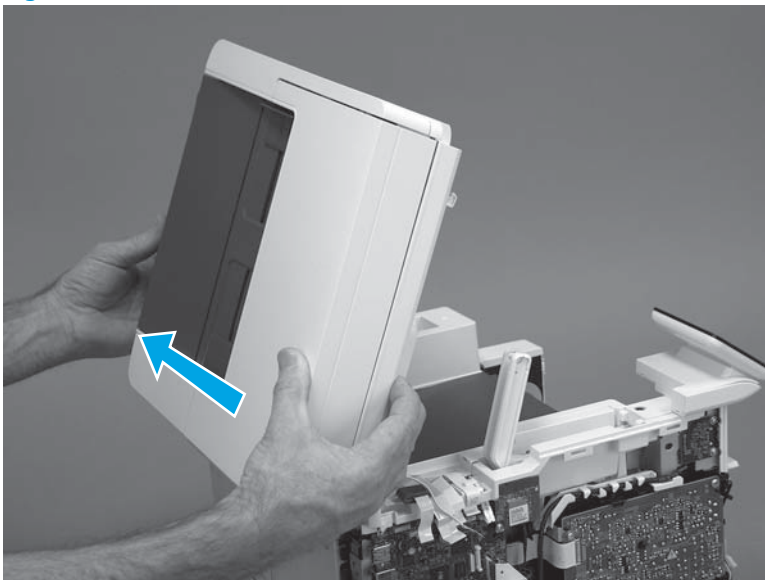

10. Remove the ISA.

Figure 1-1662 Remove the ISA

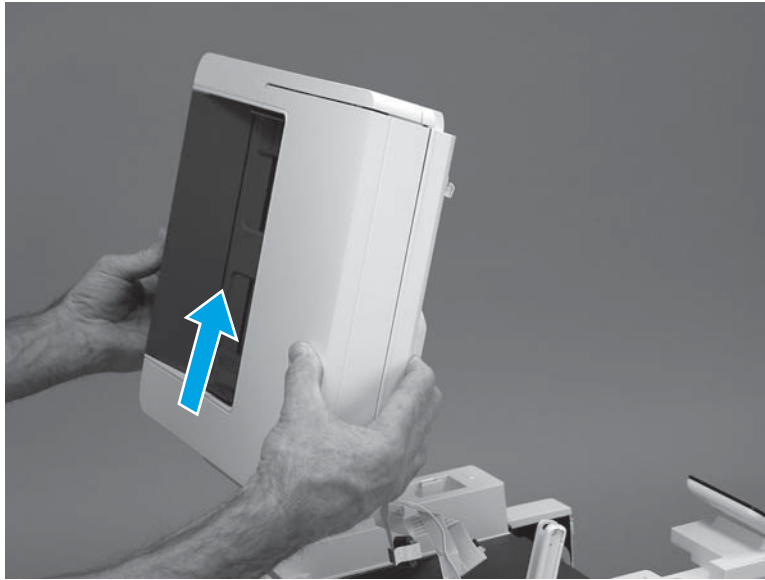

Step 6: Remove the control panel (M427/M246)

 **NOTE:** The step is for the M427/M426 printer. For the M403/M402, skip this step and go to [Step 8: Remove the top cover \(M403/M402\)](#) on page 890.

1. Disconnect one FFC (callout 1; J114), and then release the FFC from the retainer (callout 2).

Figure 1-1663 Disconnect one connector

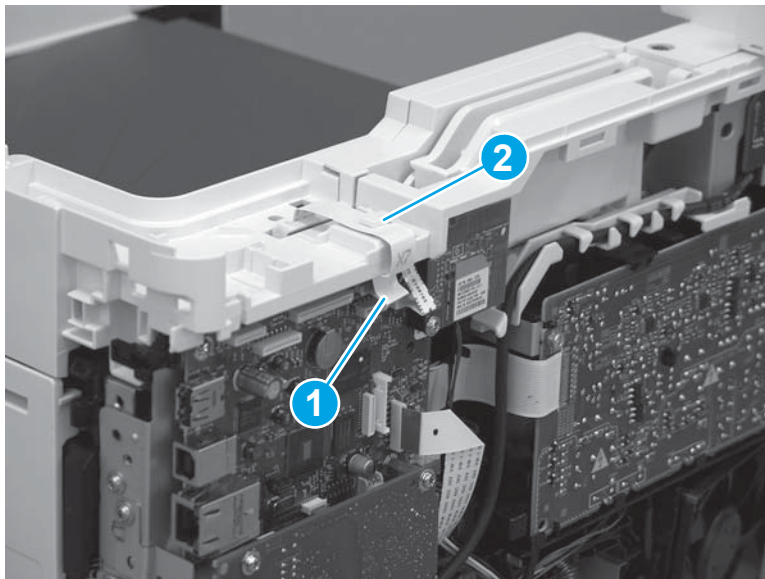

2. Remove one screw (callout 1).

Figure 1-1664 Remove one screw

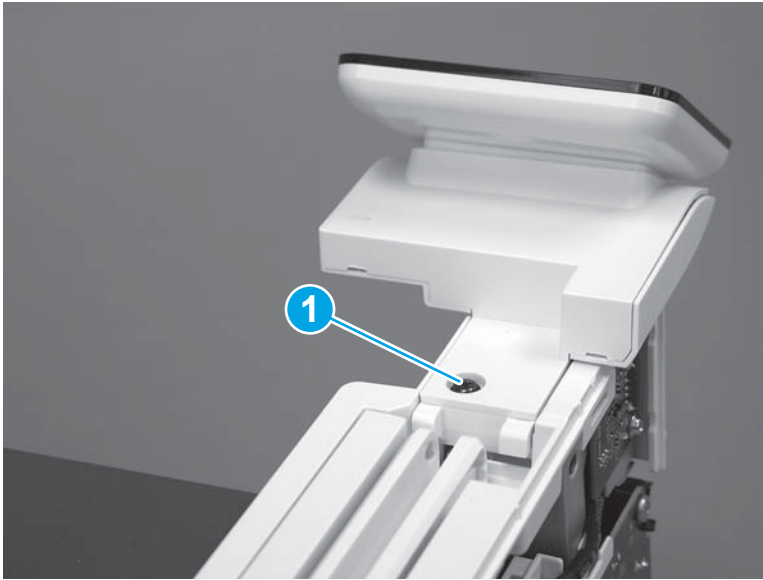

3. Use a small flat-blade screwdriver to release two tabs (callout 1) on the control-panel cable cover.

Figure 1-1665 Release two tabs

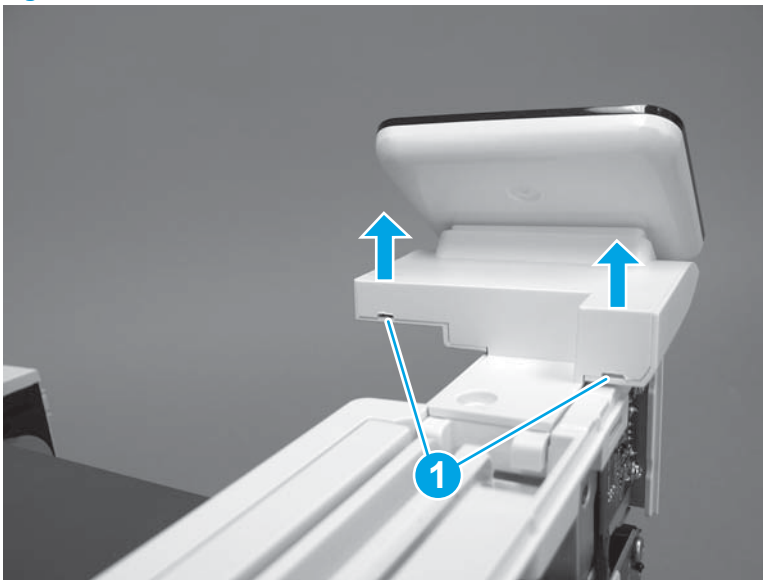

4. Remove the control-panel cable cover.

Figure 1-1666 Remove the cover

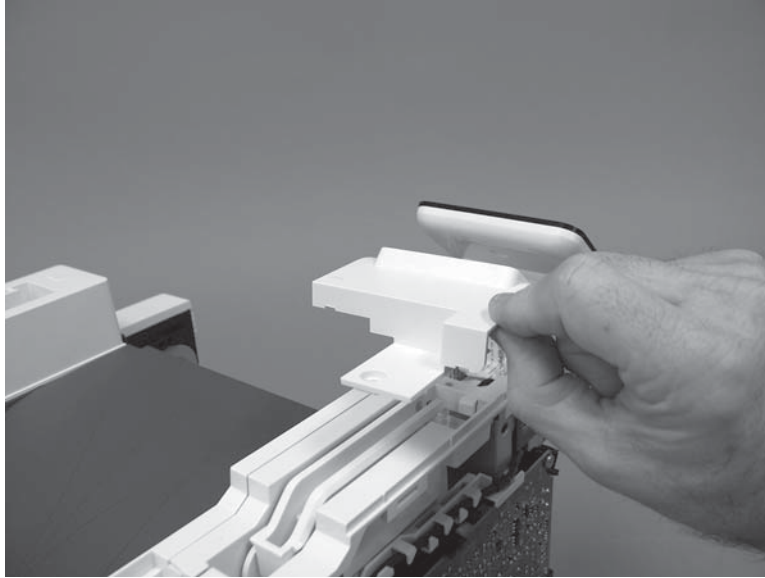

5. Remove one grounding screw (callout 1), and then move the ground cable (callout 2) out of the way.

Figure 1-1667 Remove one screw

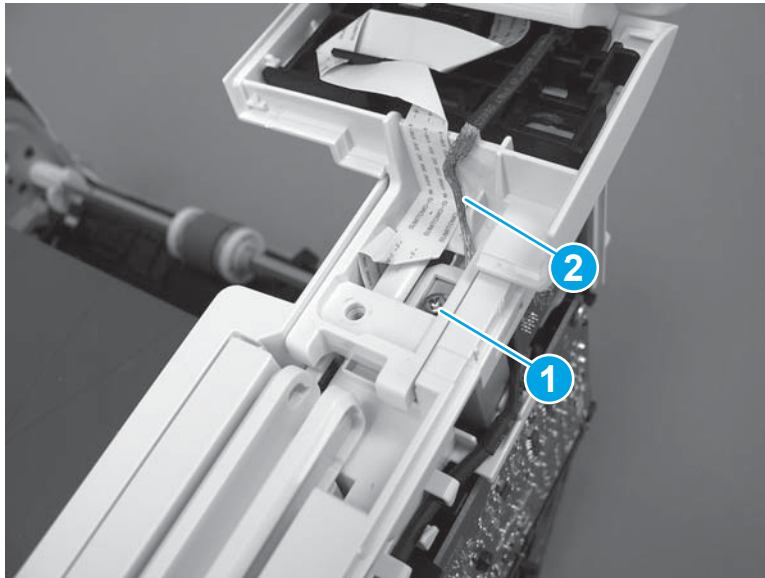

6. Move the FFC out of the way, and then remove two screws (callout 1).

Figure 1-1668 Remove two screws

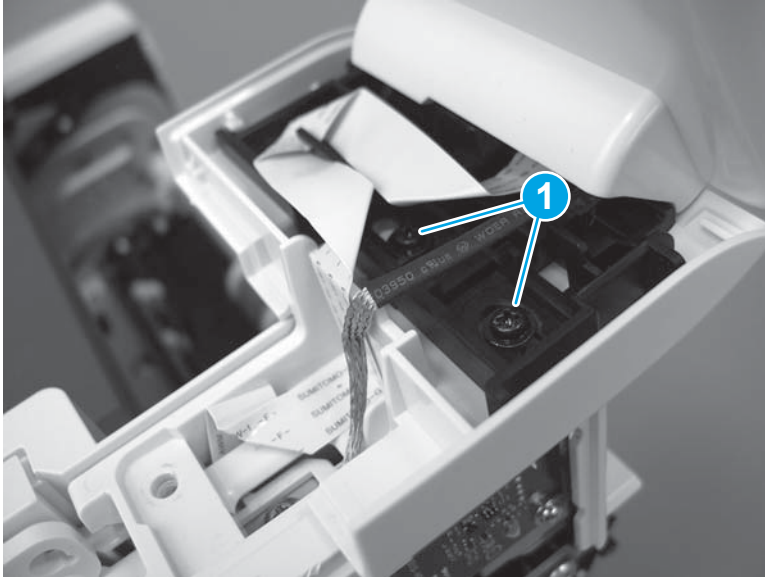

7. Slightly lift up the control-panel assembly to separate it from the top cover.

CAUTION: The control panel assembly is still connected to the printer by the FFC. Do not attempt to completely remove the assembly.

Figure 1-1669 Lift up the control-panel assembly

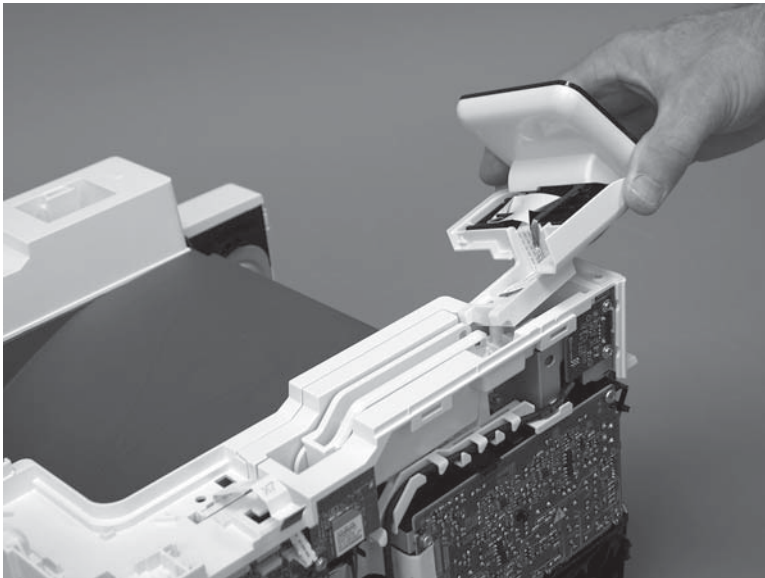

8. Lift up the control-panel FFC cover to remove the control-panel assembly.

Figure 1-1670 Remove the control-panel assembly

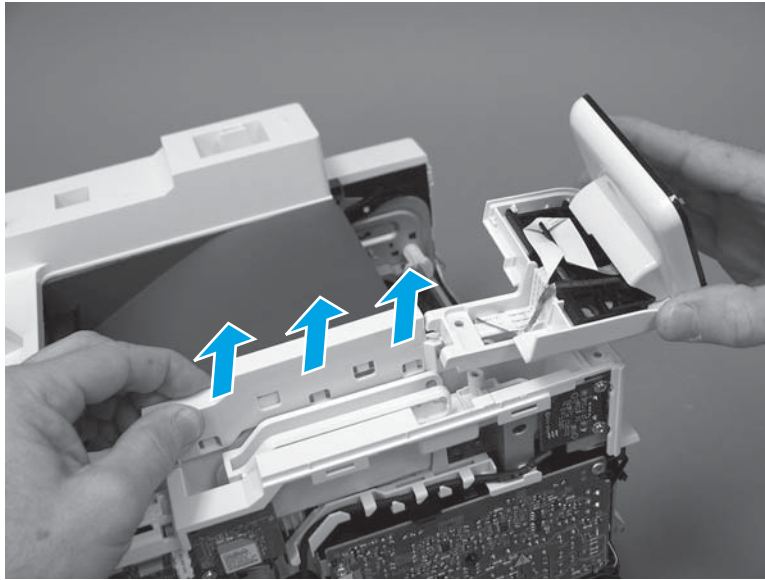

Step 7: Remove the top cover (M427/M426)

 **NOTE:** The step is for the M427/M426 printer. For the M403/M402, skip this step and go to [Step 8: Remove the top cover \(M403/M402\) on page 890](#).

1. Release the USB cable (callout 1) from the cable guide.

Figure 1-1671 Remove the USB cable

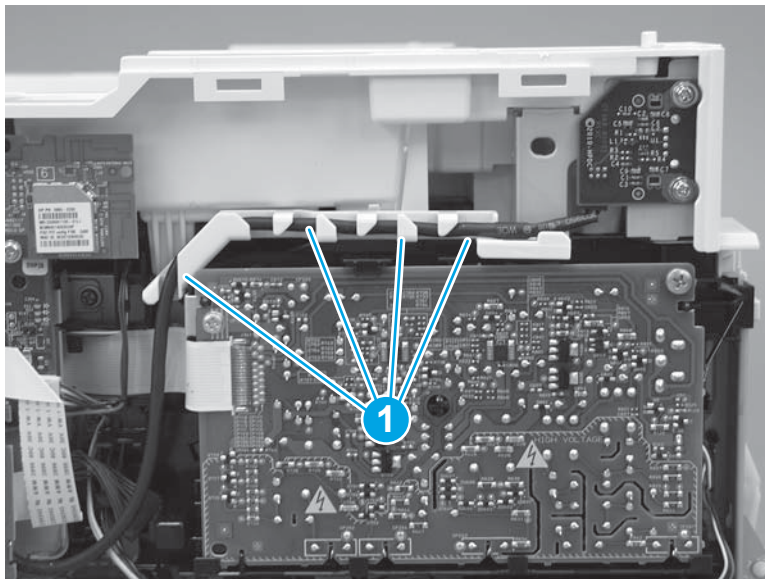

2. Remove five screws (callout 1), release four bosses (callout 2), and then remove the top cover (callout 3).

Figure 1-1672 Remove the cover

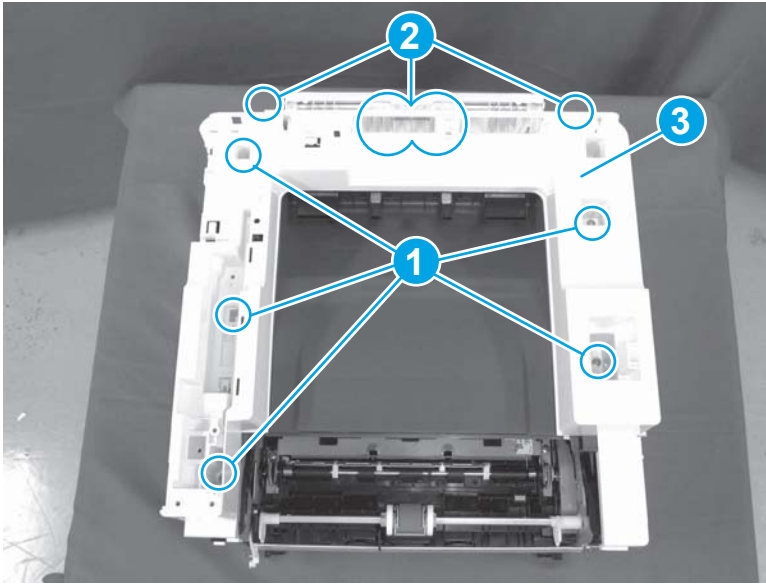

Step 8: Remove the top cover (M403/M402)



NOTE: The step is for the M403/M402 printer. For the M427/M426, skip this step and go to [Step 9: Remove the paper delivery tray \(output bin\) on page 891](#).

1. Remove one screw (callout 1).

Figure 1-1673 Remove one screw



2. At the right side of the printer, release the one boss (callout 1), and then release one tab (callout 2).

Figure 1-1674 Release one boss and one tab

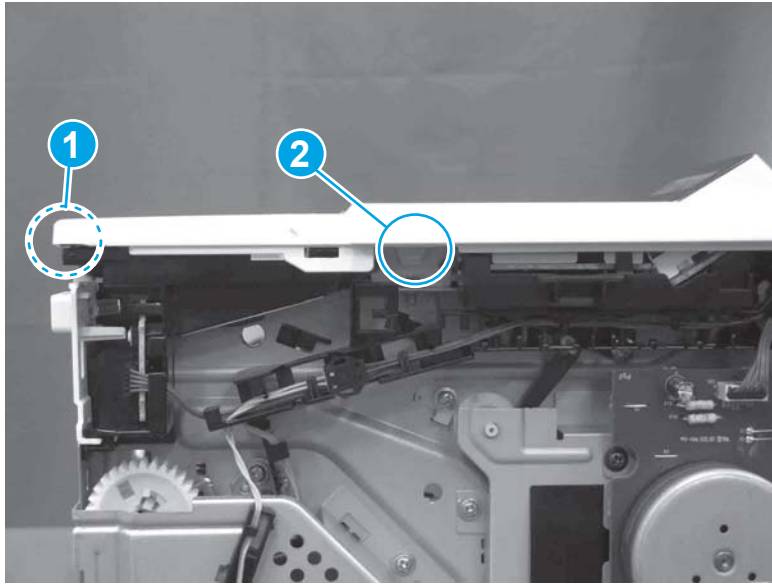

3. Release four tabs (callout 1), release four bosses (callout 2), and then remove the top cover (callout 3).



 **TIP:** Open the rear door to make releasing the bosses (callout 3) easier.

Figure 1-1675 Remove the cover

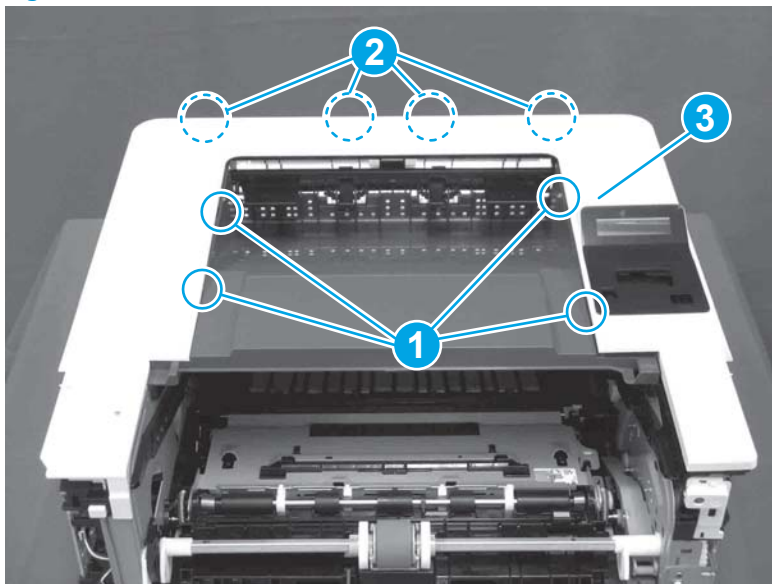

Step 9: Remove the paper delivery tray (output bin)

 **NOTE:** This procedure shows the M403/M402 model, however, the paper delivery tray (output bin) removal is similar for the M427/M426 printer.

- ▲ Release two bosses (callout 1), release two tabs (callout 2), and then remove the paper delivery tray (output bin; callout 3).

Figure 1-1676 Release two tabs

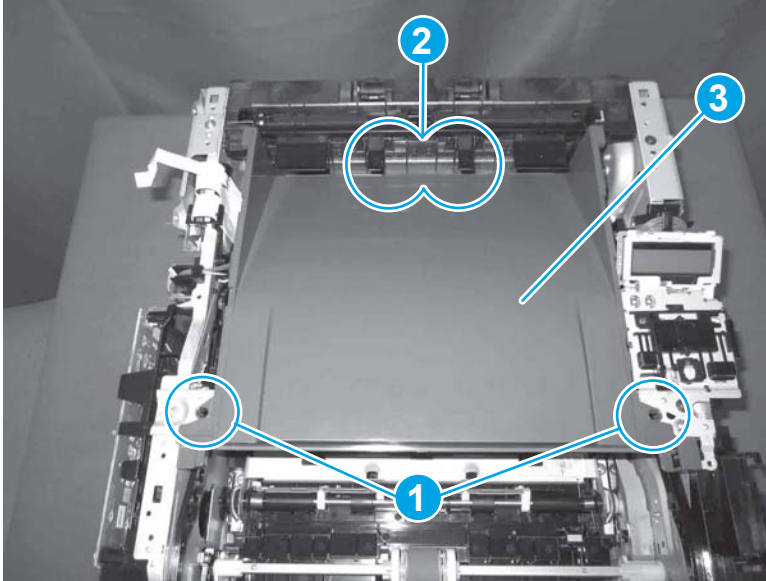

Step 10: Remove the sheet-metal formatter bracket and formatter PCA

 **NOTE:** Disconnect any remaining formatter PCA FFCs or wire-harness connectors.

1. **M427/M426 only:** Remove the guide (callout 1).

Figure 1-1677 Remove the guide

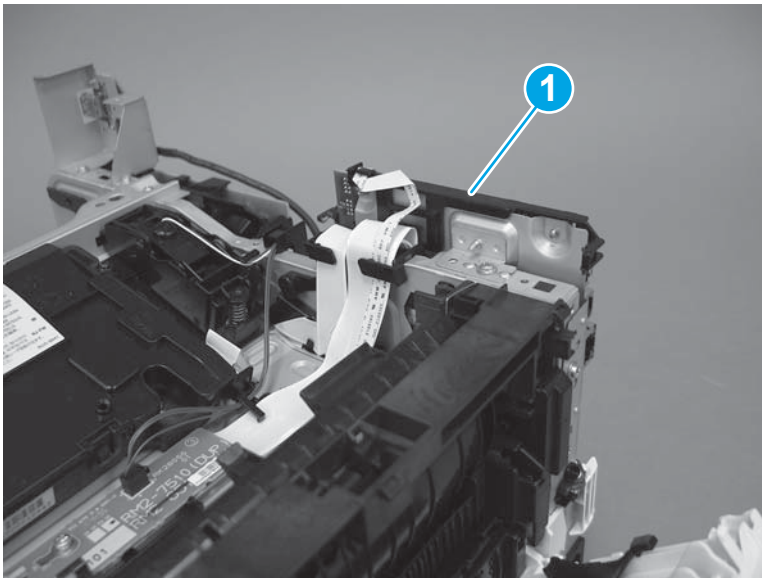

2. Remove two screws (callout 1).

Figure 1-1678 Remove two screws

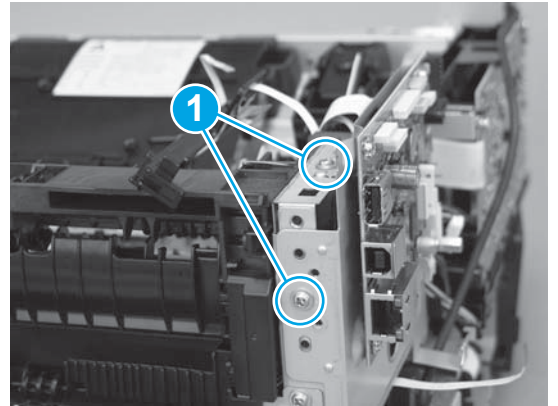
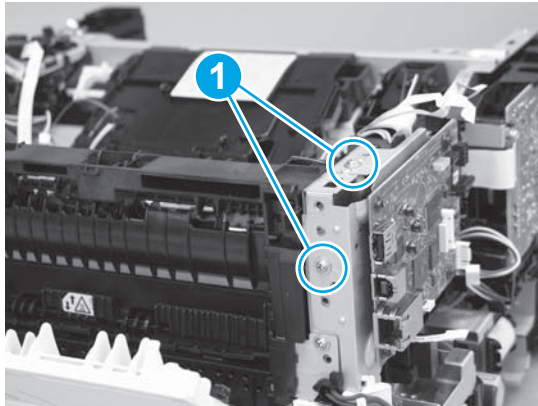

3. Disconnect one connector (callout 1), and then release the wire harness from the guide (callout 2).

Figure 1-1679 Disconnect one connector

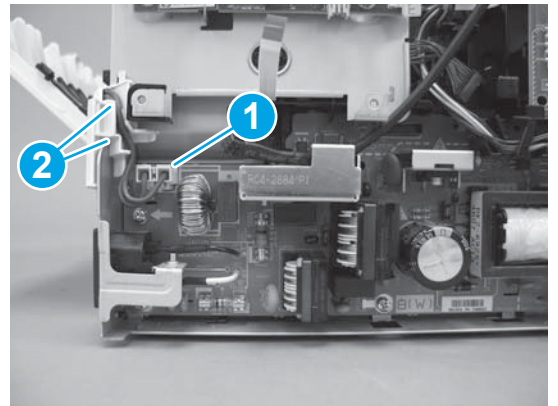
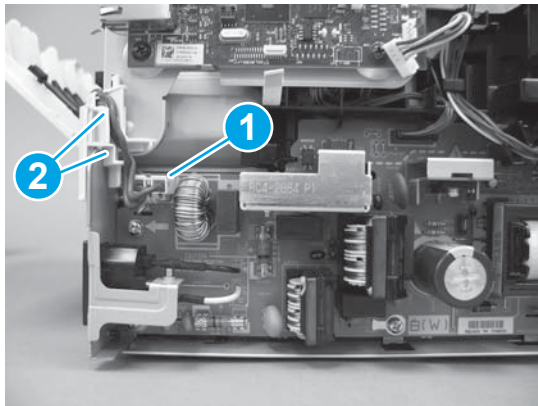

4. Remove the guide (callout 1).

Figure 1-1680 Remove the guide

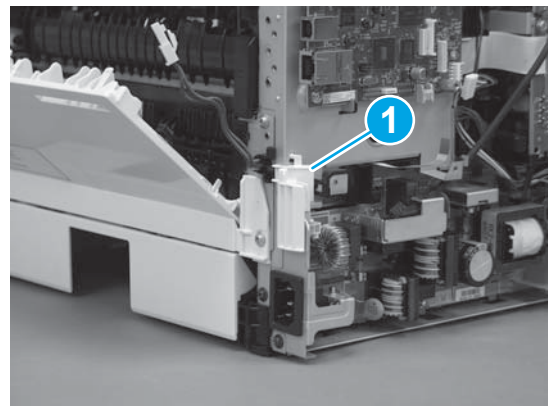
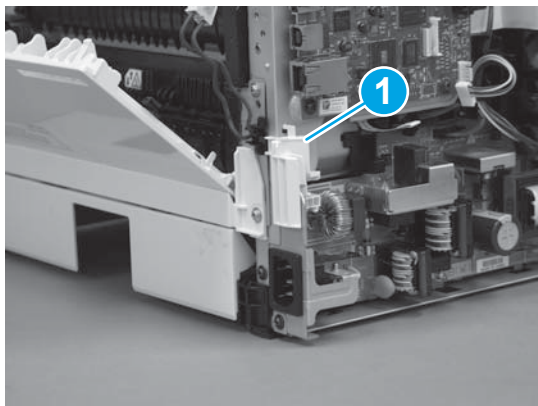

5. Remove three screws (callout 1).

Figure 1-1681 Remove three screws

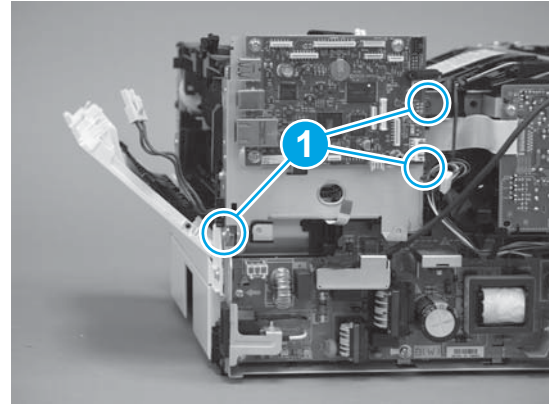
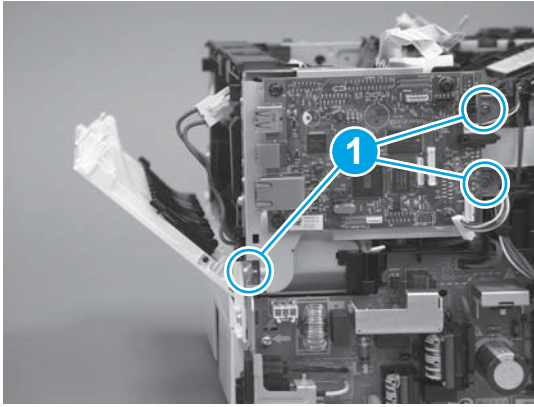

6. Remove the sheet-metal bracket and formatter PCA.

Figure 1-1682 Remove the bracket

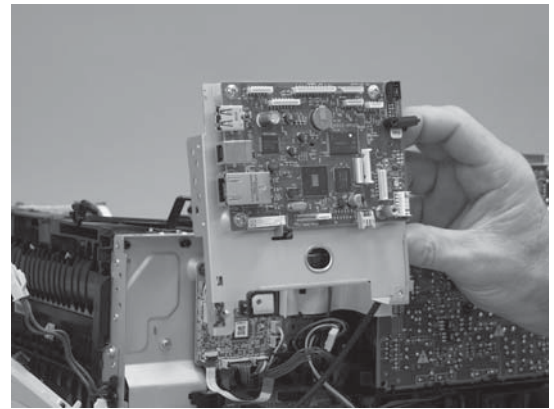
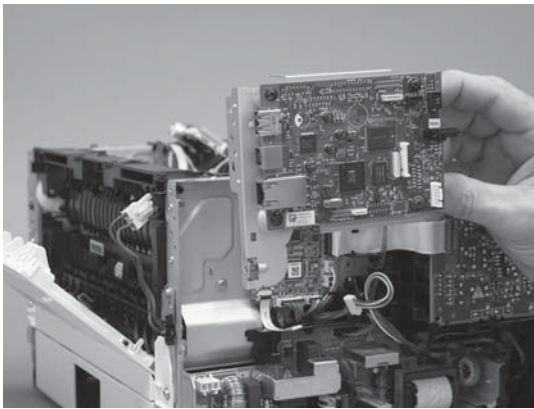

Step 11: Remove the tag-cable assembly

1. Disconnect one connector (callout 1), and then release the wire harness from the guide (callout 2).

Figure 1-1683 Disconnect one connector

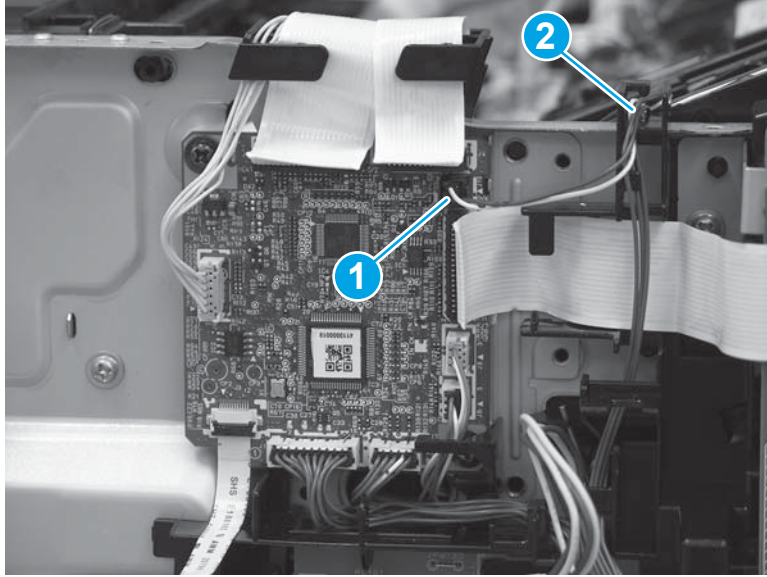

2. Remove one screw (callout 1).

Figure 1-1684 Remove one screw

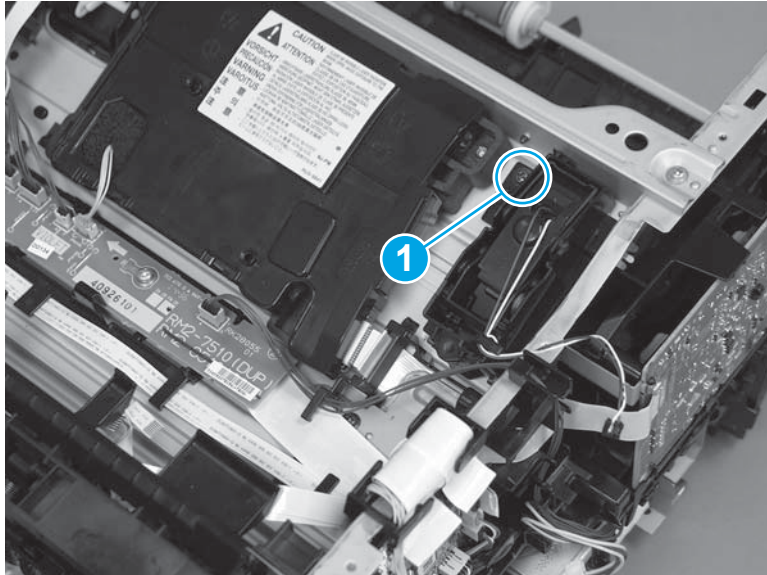

3. Remove the tag-cable assembly.

Figure 1-1685 Remove the tag-cable assembly

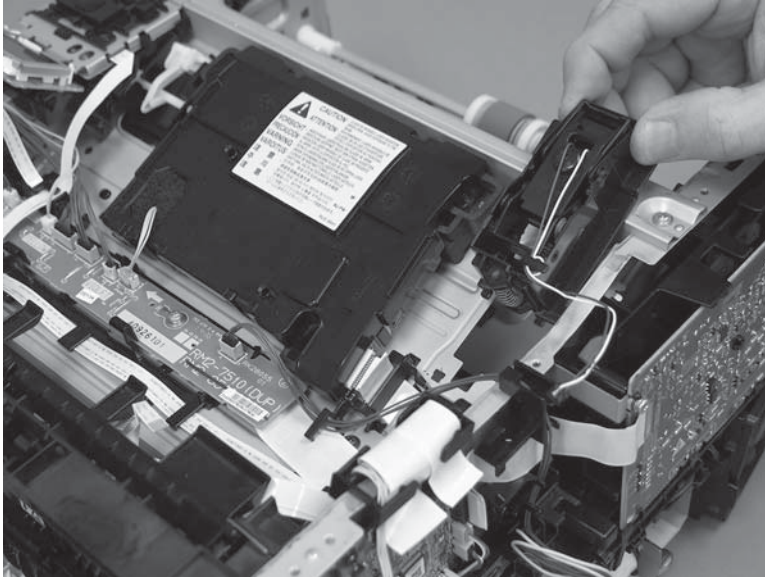

Step 12: Remove the laser scanner FFC

1. Disconnect one FFC (callout 1), and then release it from the guide (callout 2).

Figure 1-1686 Disconnect one FFC

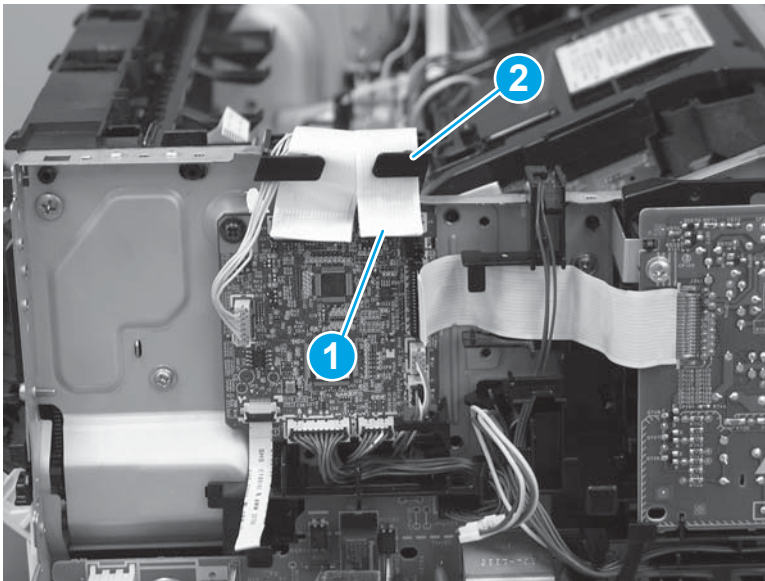

2. Remove one screw (callout 1), and then remove the sheet-metal plate (callout 2).

Figure 1-1687 Remove one screw and the sheet-metal plate

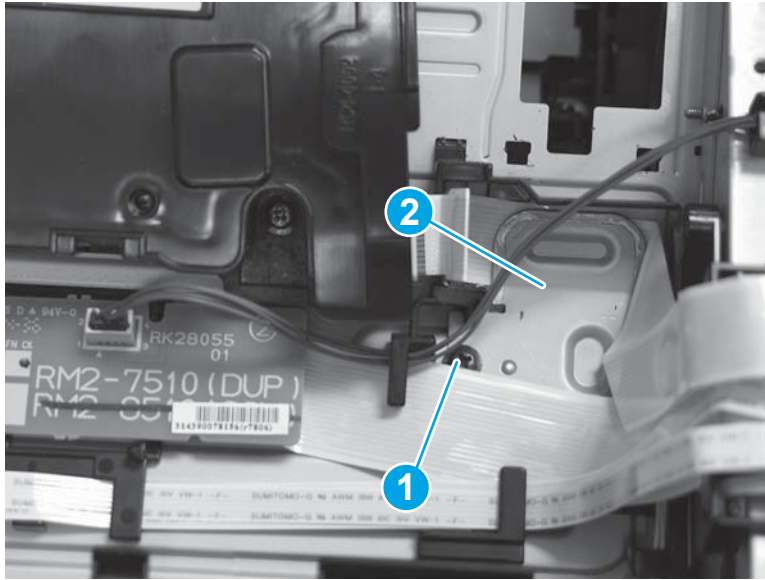

3. Disconnect one FFC (callout 1).

Figure 1-1688 Disconnect one FFC

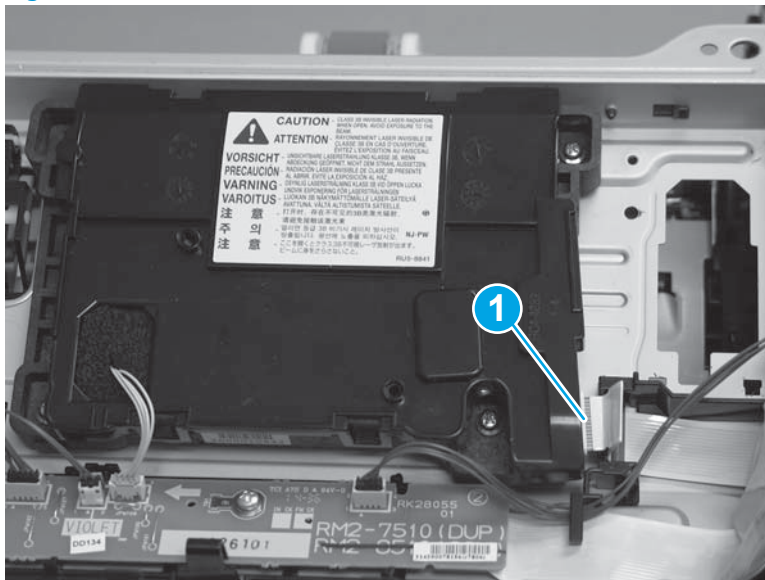

4. Slightly flex the holder (callout 1), and then release the FFC ferrite (callout 2).

 **Reinstallation tip:** Do not discard the ferrite. It will be installed on the replacement FFC.

Figure 1-1689 Release the ferrite

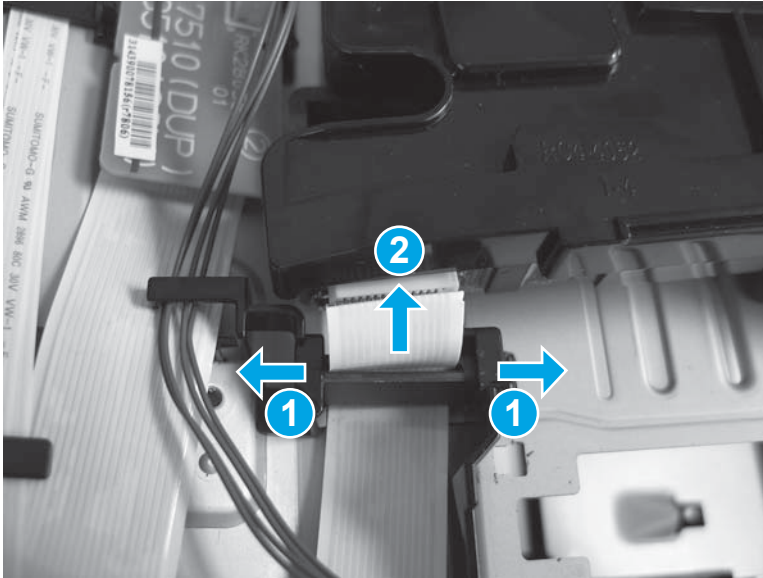

5. Remove the FFC.

Figure 1-1690 Remove the FFC

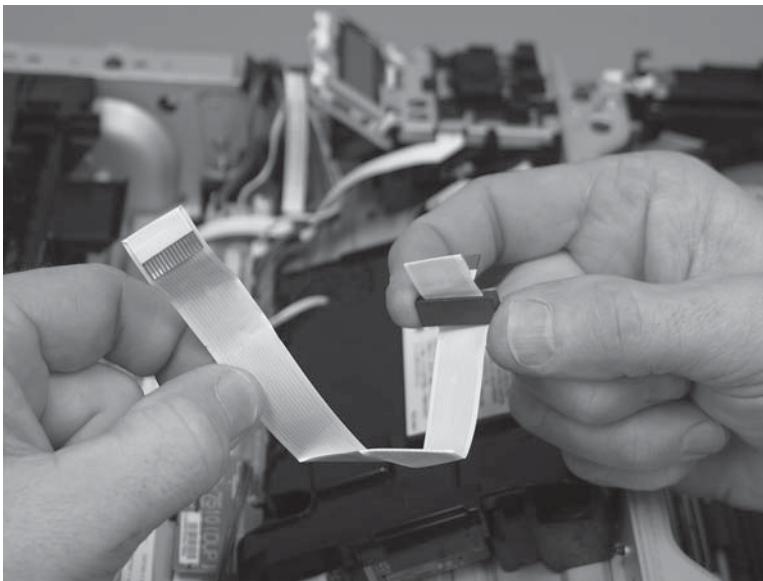

Step 13: Unpack the replacement assembly

Unpack the replacement part from the packaging.

<http://www8.hp.com/us/en/hp-information/environment/product-recycling.html>

 **NOTE:** HP recommends responsible disposal of the defective part.

Figure 1-1691 Recycle and unpack

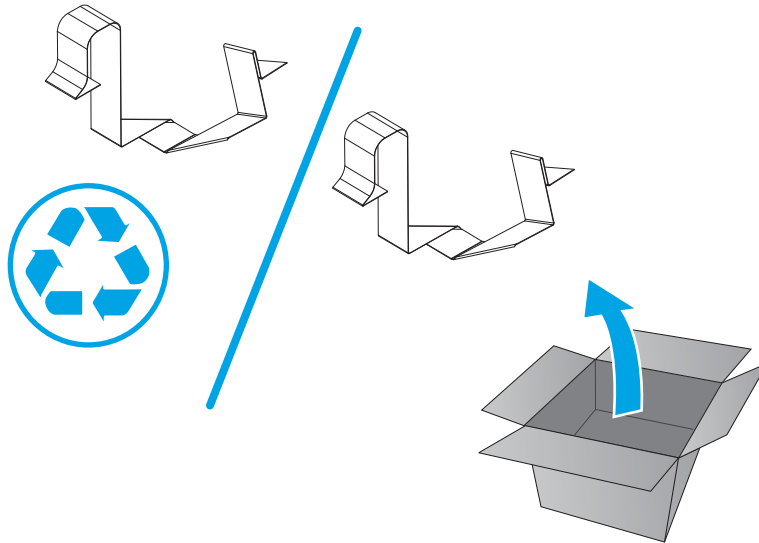

Step 14: Install the laser scanner FFC

1. Install the ferrite on the replacement FFC.

Figure 1-1692 Install the ferrite

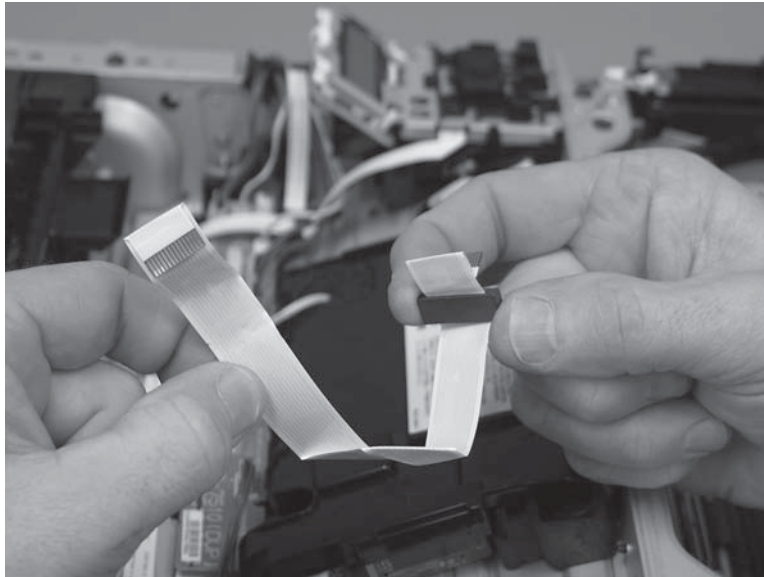

2. Slightly flex the holder (callout 1), and then install the FFC ferrite (callout 2) in the holder.

Figure 1-1693 Install the FFC

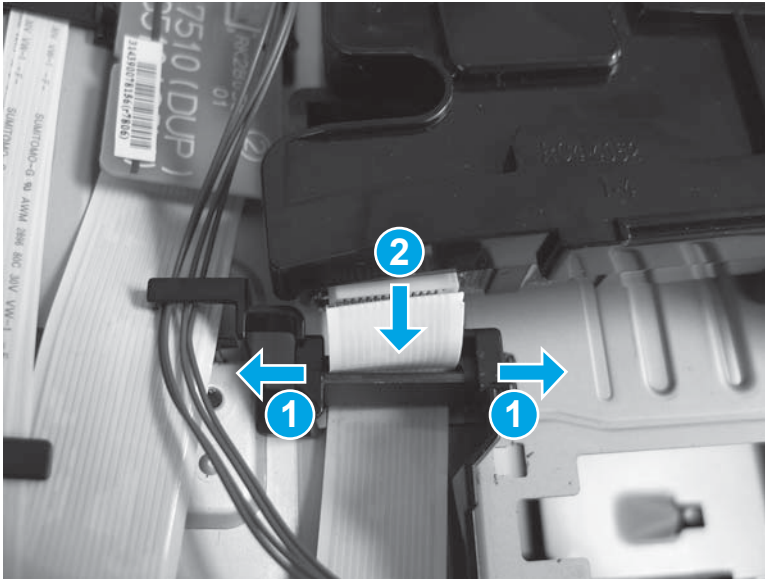

3. Connect one FFC (callout 1).

Figure 1-1694 Connect one FFC

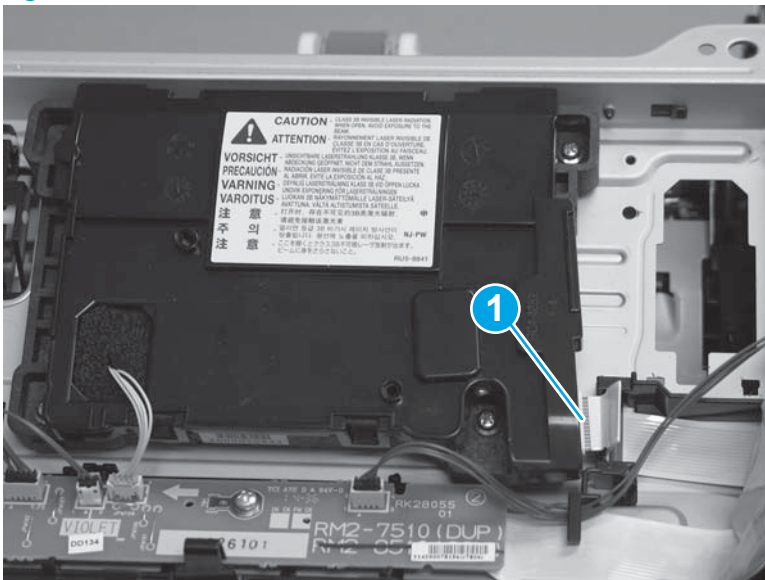

4. Install the sheet-metal plate (callout 1), and then install one screw (callout 2).

Figure 1-1695 Install the sheet-metal plate and install one screw

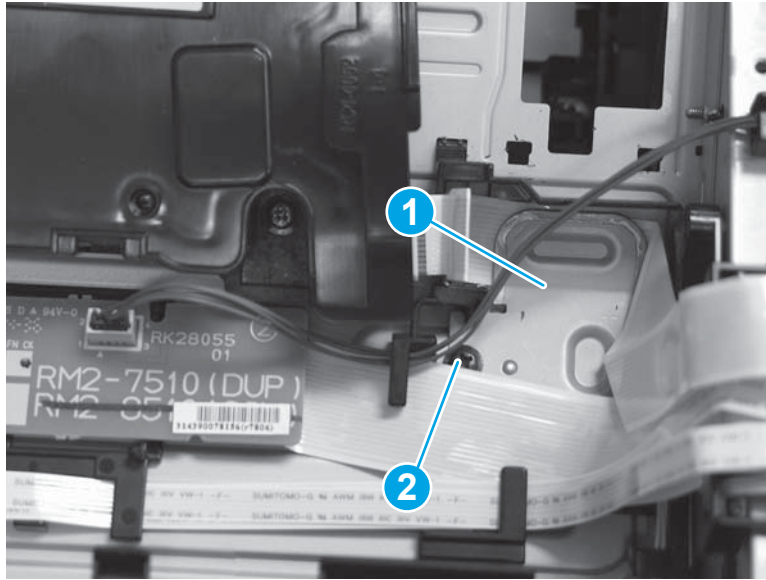

5. Install the FFC in the guide (callout 1), and then connect the FFC (callout 1) to the DC controller.

Figure 1-1696 Connect one FFC

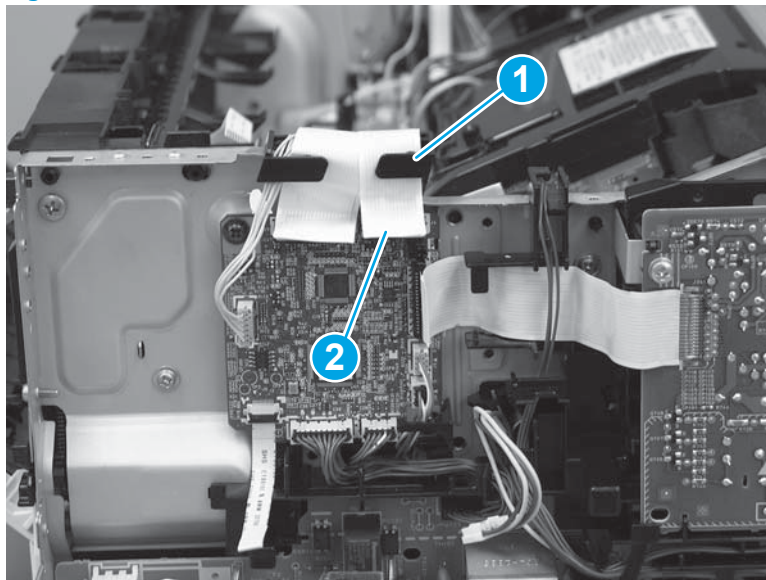

Step 15: Install the tag-cable assembly

1. Position the assembly on the printer.

 **IMPORTANT:** Make sure that the assembly is flat against the chassis. If the assembly is not correctly installed, it might not make proper contact with the toner cartridge.

Figure 1-1697 Install the assembly



2. Install one screw (callout 1).

Figure 1-1698 Install one screw

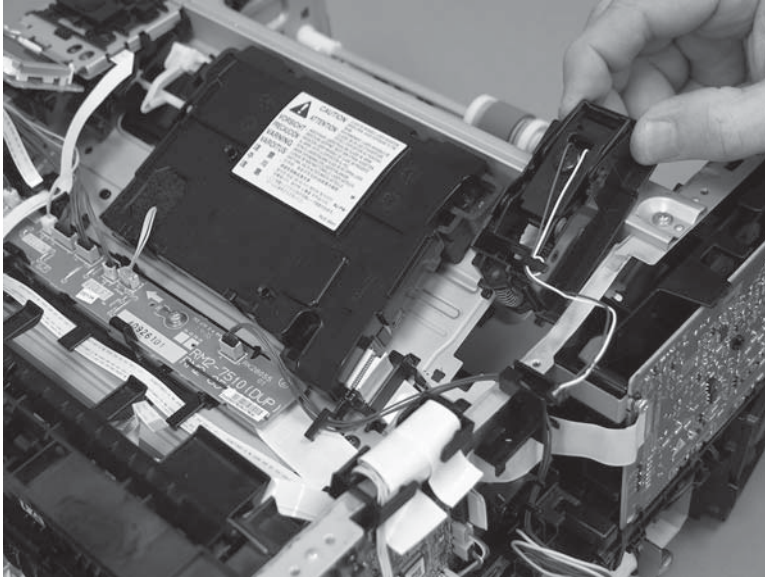
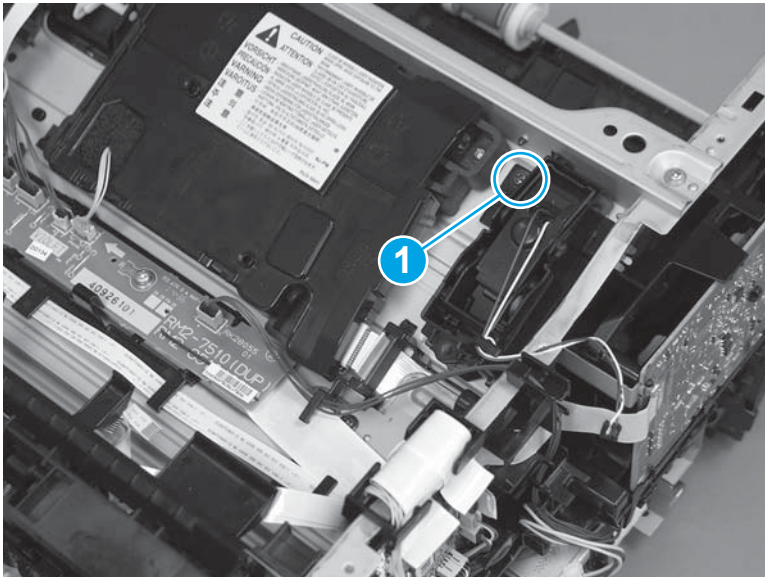

3. Install the wire harness in the guide (callout 1), and then connect one connector (callout 2).

Figure 1-1699 Connect one connector

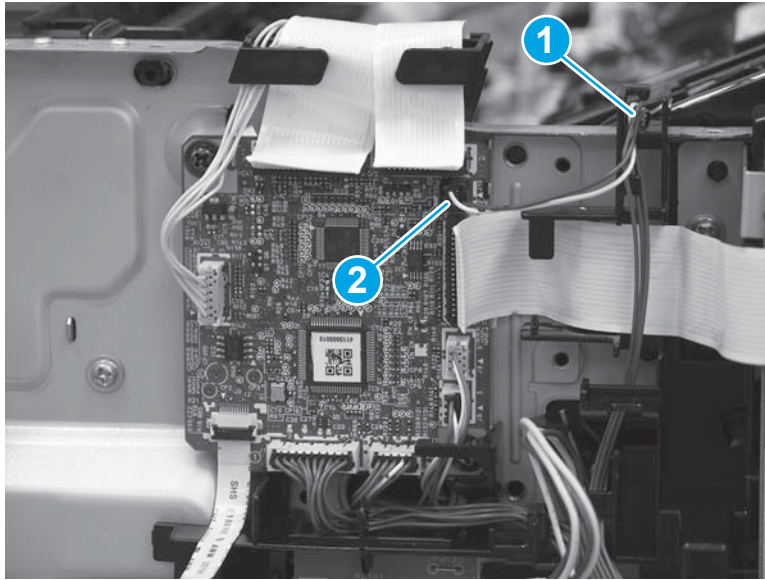

Step 16: Install the sheet-metal formatter bracket and formatter PCA

 **NOTE:** Do not forget to connect any formatter PCA FFCs or wire-harness connectors that were disconnected when the bracket was removed.

1. Position the sheet-metal bracket and formatter PCA on the printer.

Figure 1-1700 Install the bracket

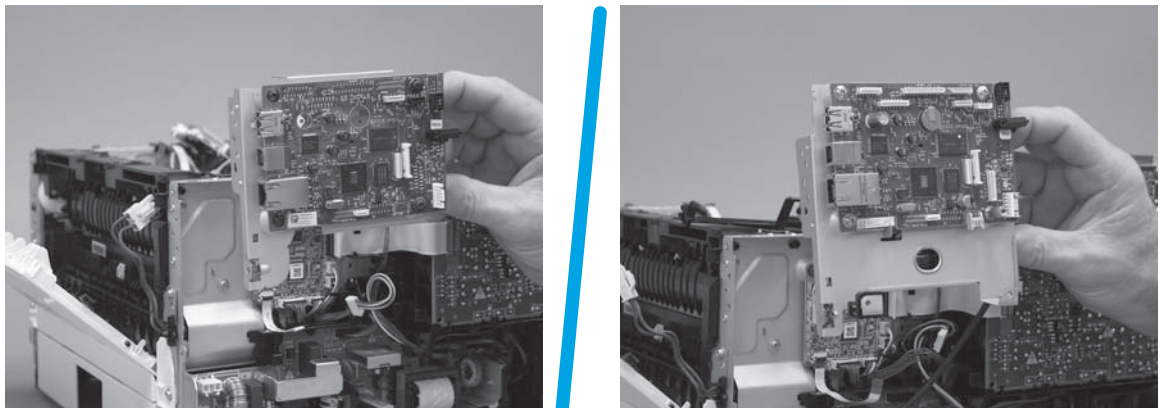

2. Install three screws (callout 1).

Figure 1-1701 Install three screws

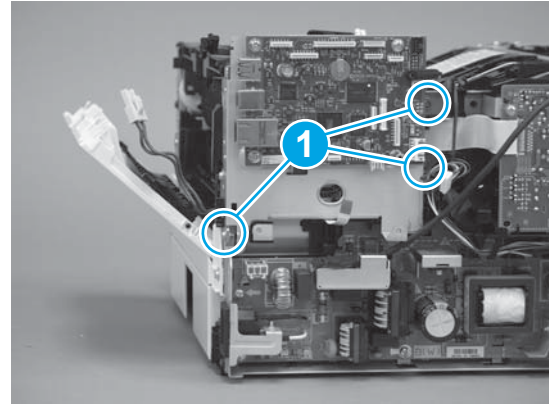
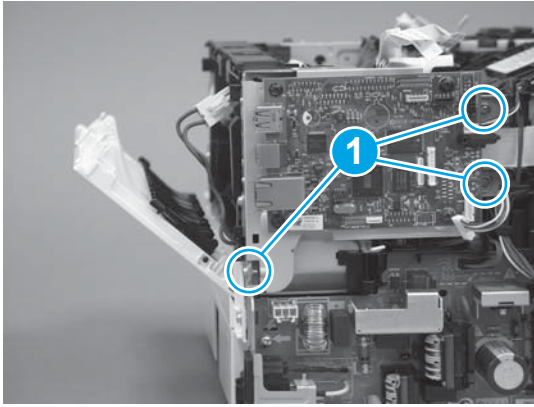

3. Install the guide (callout 1).

Figure 1-1702 Install the guide

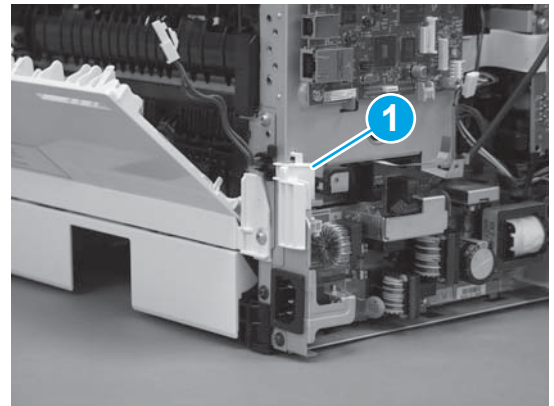
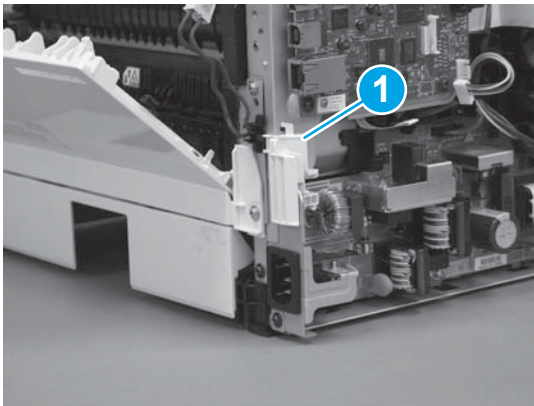

4. Connect one connector (callout 1), and then install the wire harness in the guide (callout 2).

Figure 1-1703 Connect one connector

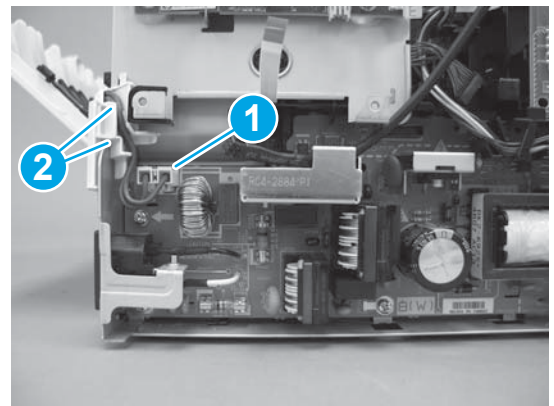
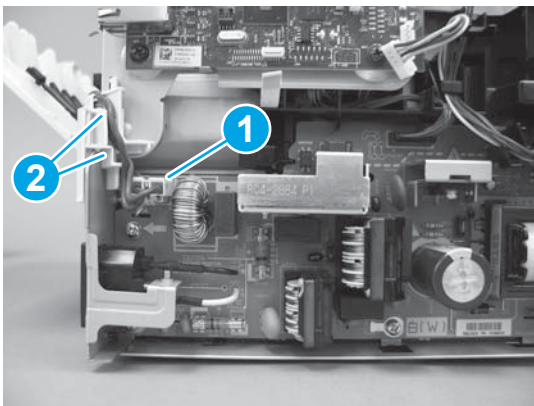

5. Install two screws (callout 1).

Figure 1-1704 Install two screws

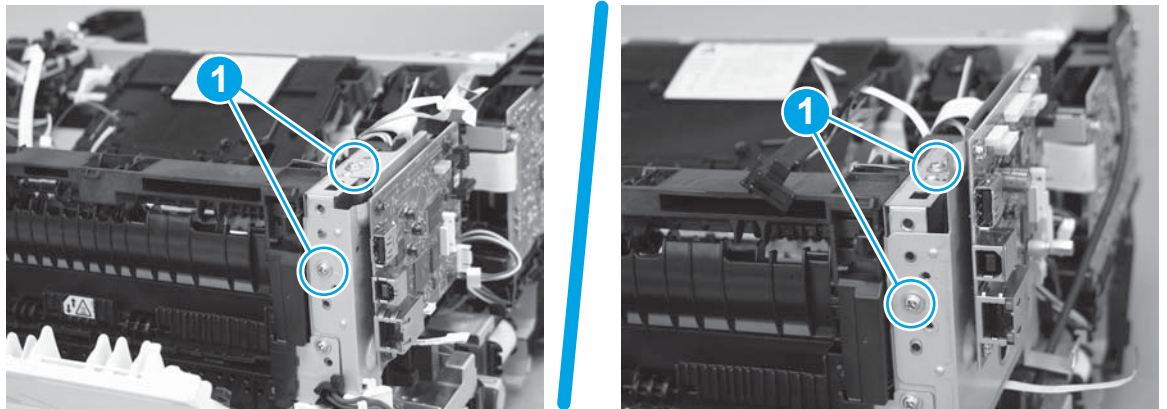

6. **M427/M426 only:** Install the guide (callout 1).

Figure 1-1705 Install the guide

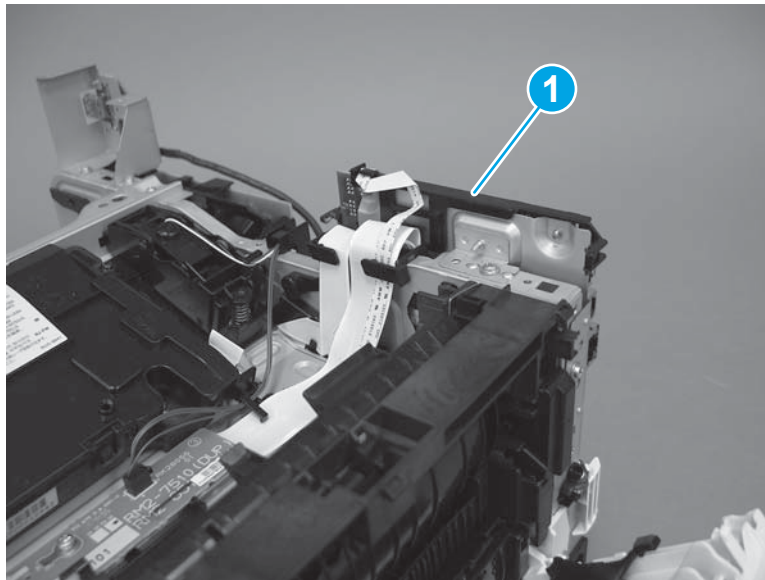

Step 17: Install the paper delivery tray (output bin)

 **NOTE:** This procedure shows the M403/M402 model, however, the paper delivery tray (output bin) removal is similar for the M427/M426 printer.

- ▲ Position the remove the paper delivery tray (output bin; callout 1) on the printer, engage two tabs (callout 2), and then engage two bosses (callout 3).

Figure 1-1706 Engage two tabs

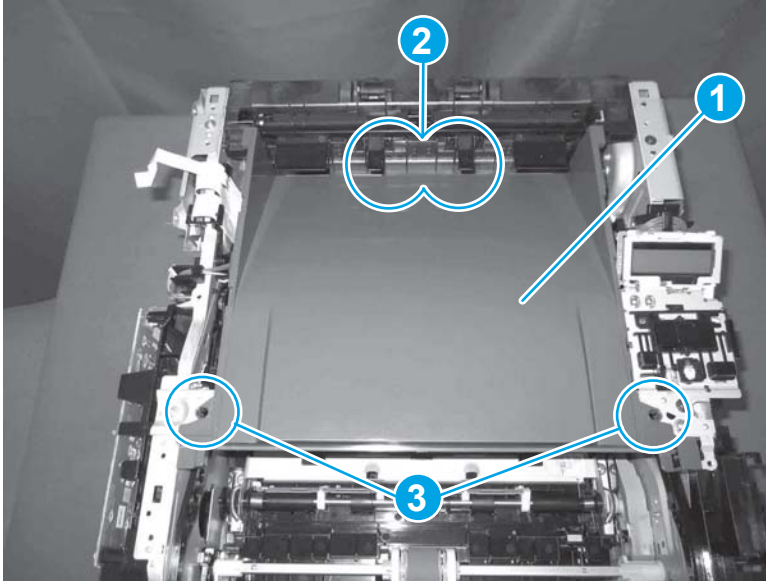

Step 18: Install the top cover (M403/M402)

 **NOTE:** The step is for the M403/M402 printer. For the M427/M426, skip this step and go to [Step 19: Install the top cover \(M427/M426\) on page 908](#).

1. Position the rear edge of the cover on the printer.

Figure 1-1707 Install the cover

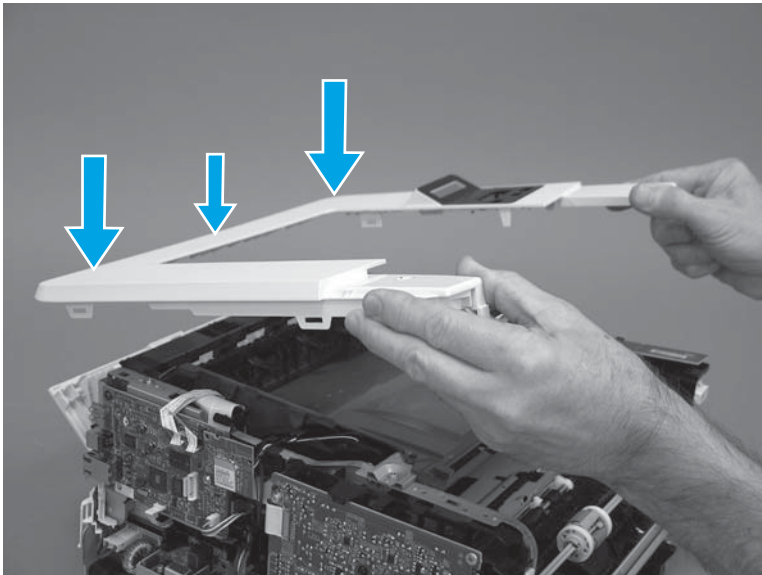

- Engage four bosses (callout 1), rotate the front of the cover down (callout 2) and onto from the printer, and then engage four tabs (callout 3).

Figure 1-1708 Engage four bosses and tabs

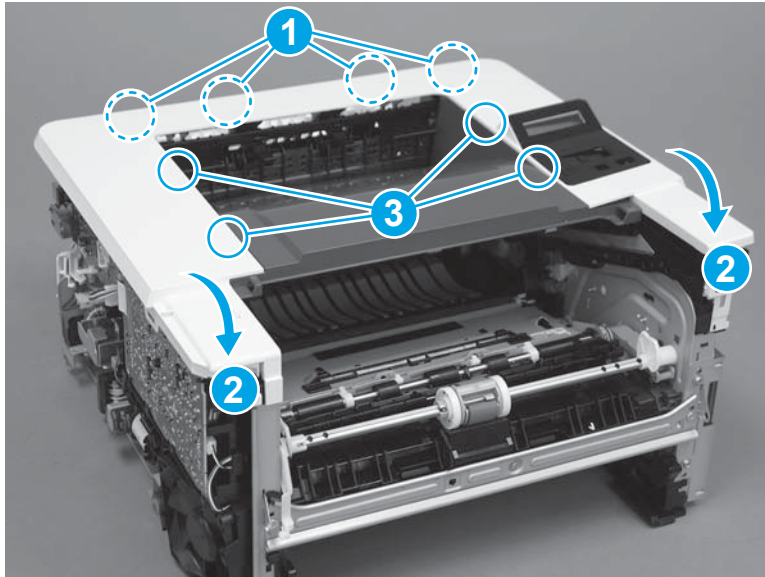

- At the right side of the printer, engage the one boss and one tab (callout 1).

Figure 1-1709 Engage one boss and one tab

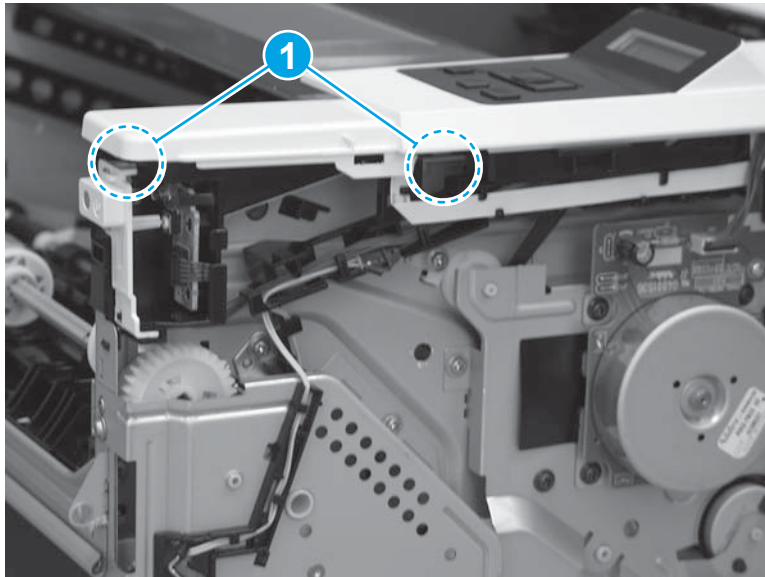

4. Install one screw (callout 1).

Figure 1-1710 Install one screw

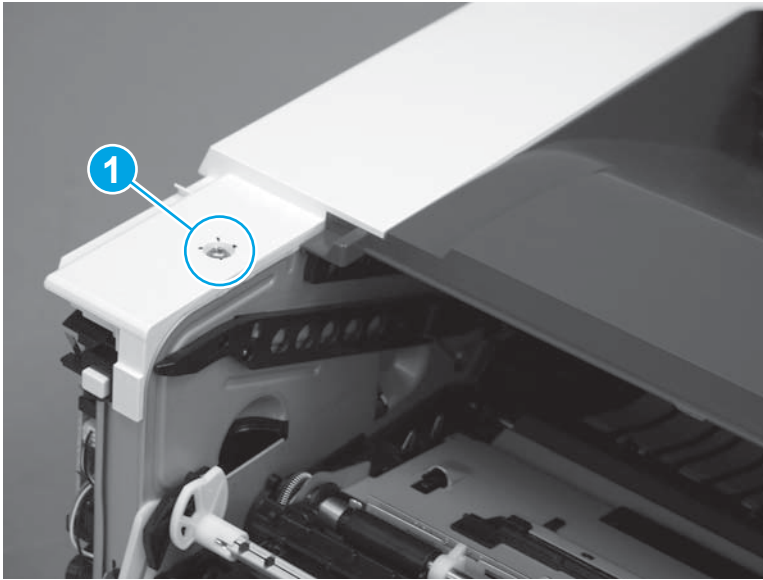

Step 19: Install the top cover (M427/M426)

 **NOTE:** The step is for the M427/M426 printer. For the M403/M402, skip this step and go to [Step 22: Install the right cover on page 919](#).

1. Position the rear edge of the top cover on the printer.

Figure 1-1711 Install the cover

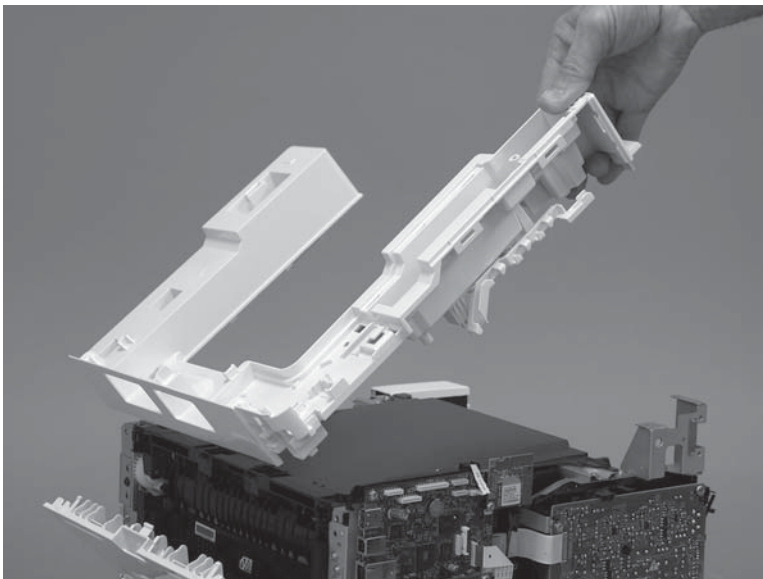

2. Engage four bosses (callout 1).

Figure 1-1712 Engage four bosses

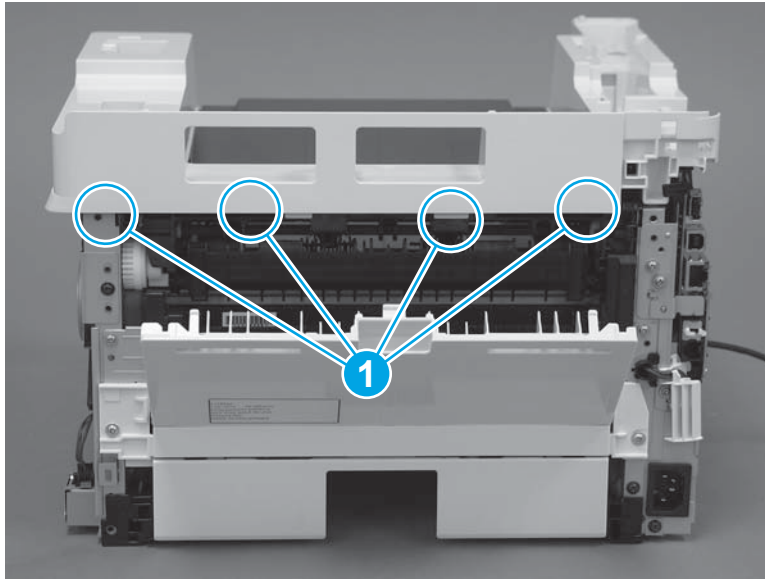

3. Rotate the front edge of the cover down.

Figure 1-1713 Rotate the front edge of the cover down

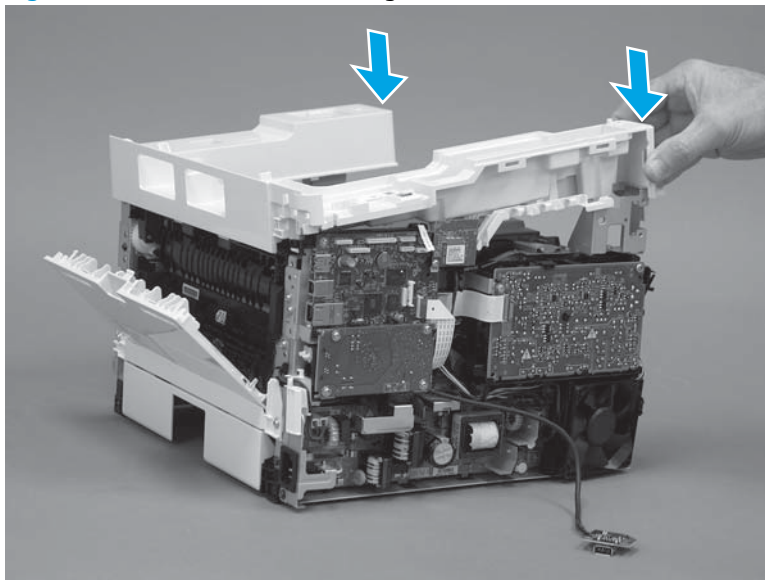

4. Install the USB cable (callout 1) in the guide.

Figure 1-1714 Install the USB PCA

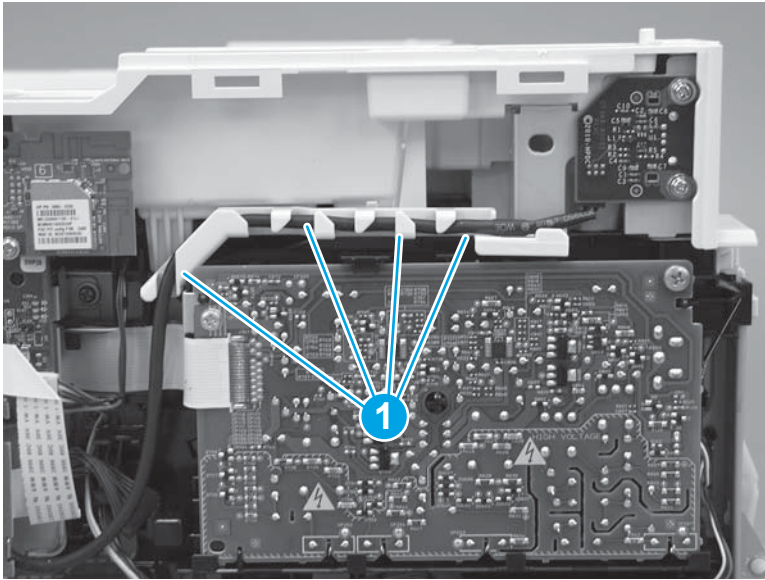

5. Install five screws (callout 1).

Figure 1-1715 Install five screws

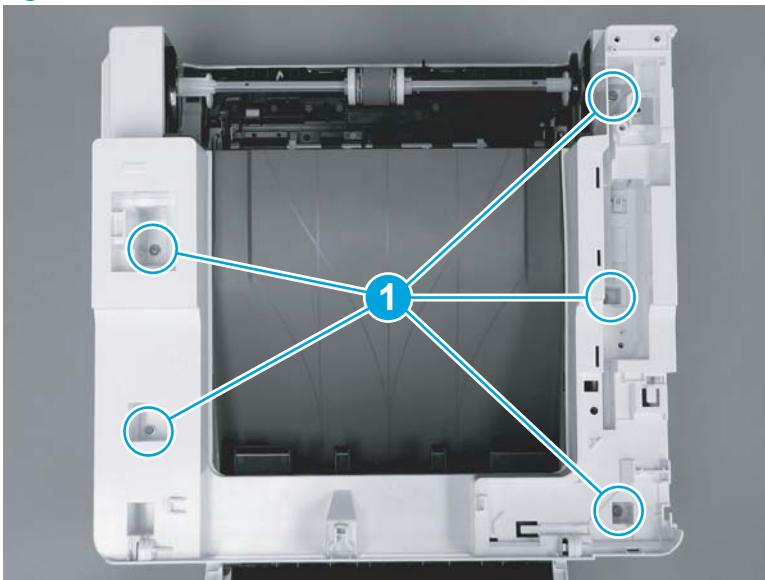

Step 20: Install the control panel (M427/M246)

 **NOTE:** The step is for the M427/M426 printer. For the M403/M402, skip this step and go to [Step 22: Install the right cover on page 919](#).

1. Slide the control-panel FFC cover into the slot in the top cover (next to the document feeder support arm) to install it.

Figure 1-1716 Install the control-panel FFC cover

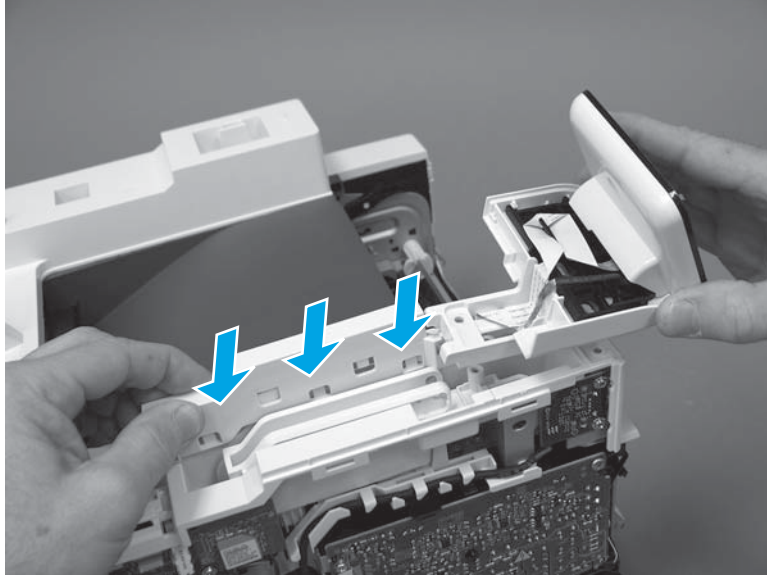

2. Install the control-panel assembly on the top cover.

Figure 1-1717 Install the control-panel assembly

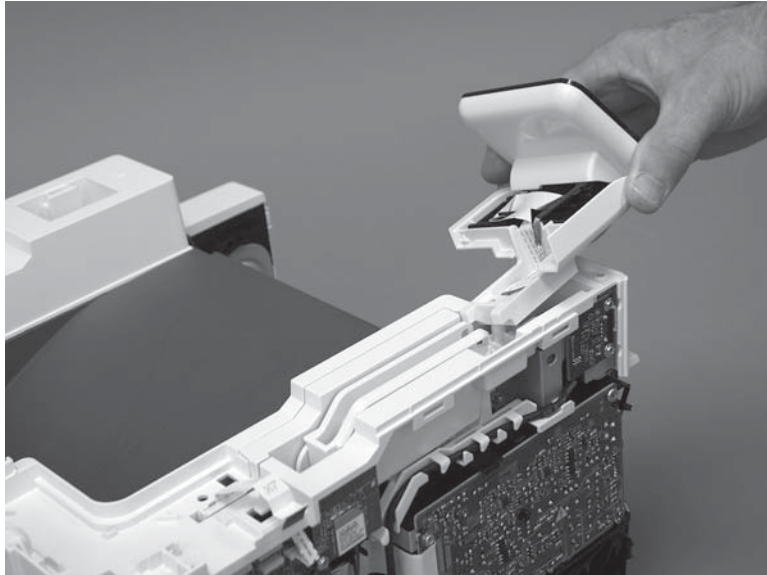

3. Move the FFC out of the way, and then install two screws (callout 1).

Figure 1-1718 Install two screws

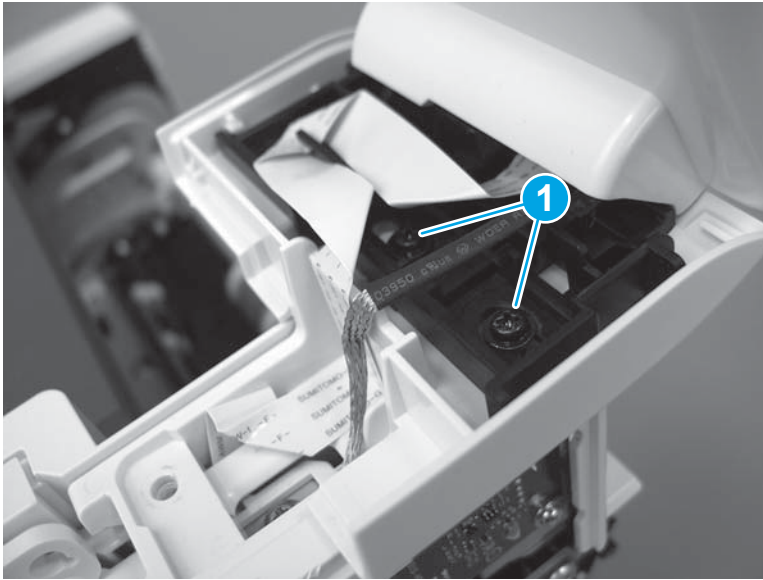

4. Install one grounding screw (callout 1), and then make sure that the ground cable (callout 2) is properly routed.

Figure 1-1719 Remove one screw

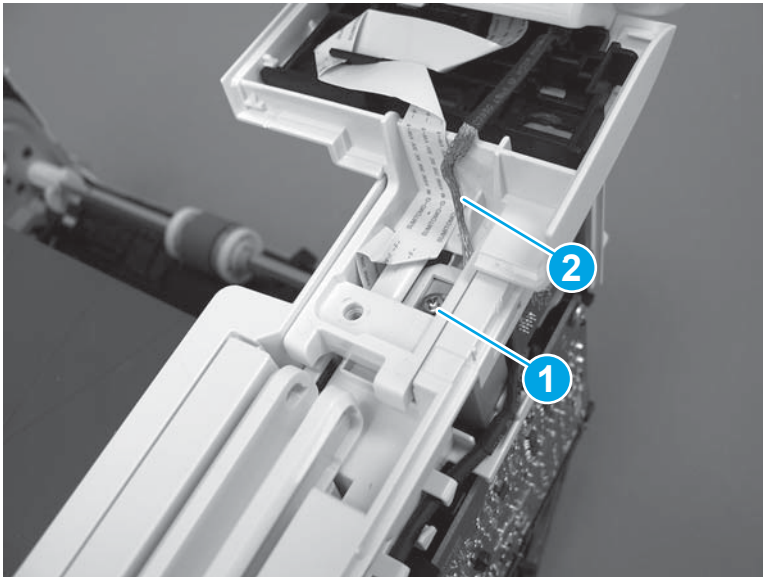

5. Install the control-panel cable cover.

Figure 1-1720 Install the cover

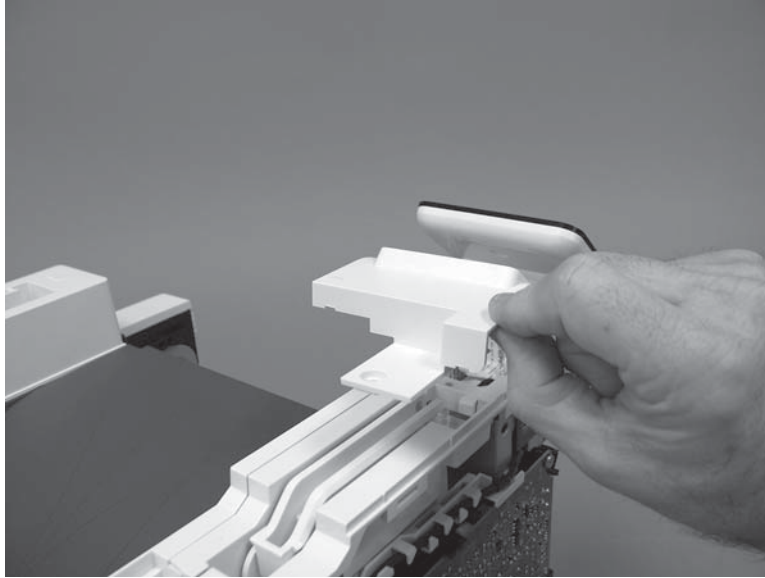

6. Make sure that the two tabs (callout 1) on the cover snap into place.

Figure 1-1721 Engage two tabs

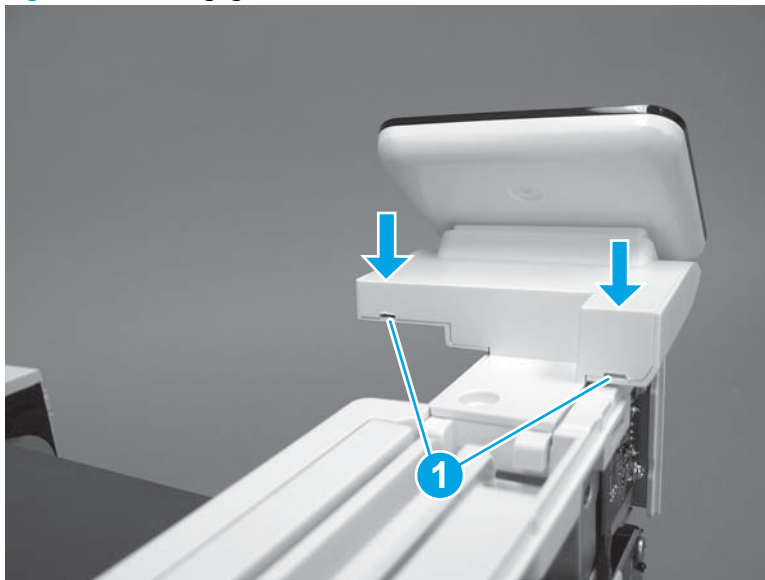

7. Install one screw (callout 1).

Figure 1-1722 Install one screw

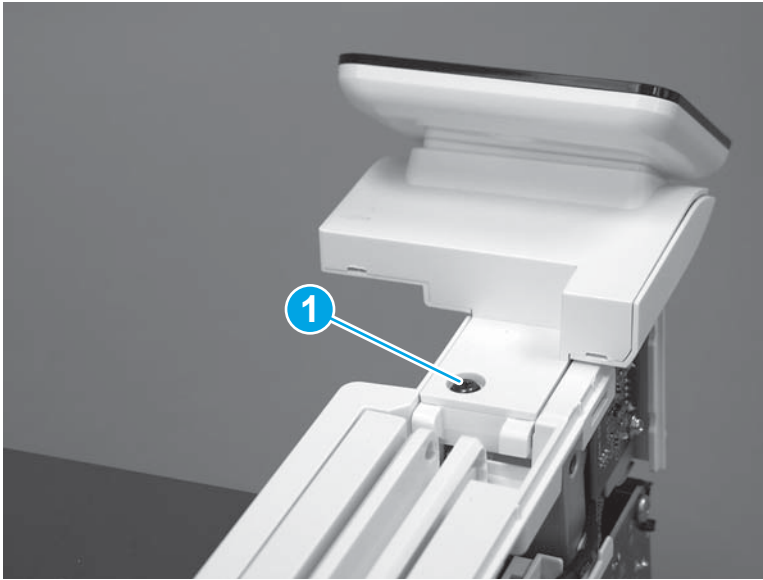

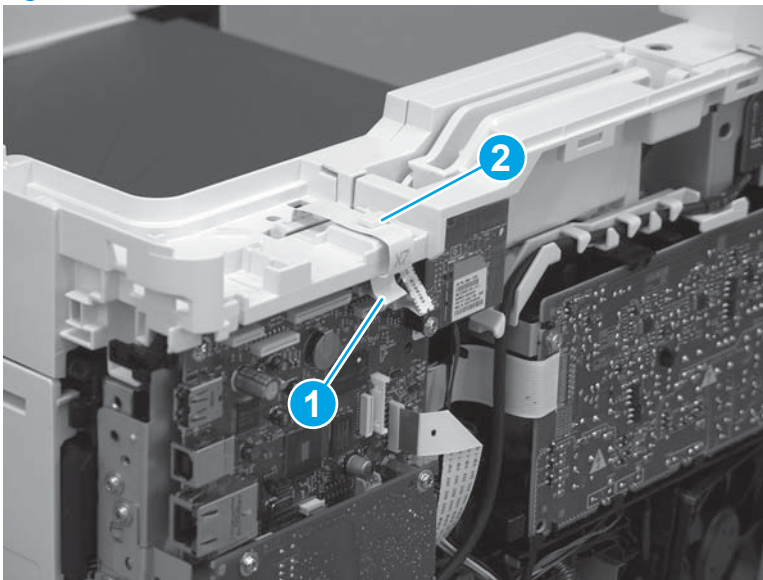

8. Install the FFC in the retainer (callout 1), and then connect one FFC (callout 1; J114).

Figure 1-1723 Connect one connector



Step 21: Install the integrated scanner assembly (M427/M246)

 **NOTE:** The step is for the M427/M426 printer. For the M403/M402, skip this step and go to [Step 22: Install the right cover on page 919](#).

 **NOTE:** M427/M426 models only. The integrated scanner assembly (ISA) includes the sub-scanner assembly (SSA) and the automatic document feeder (ADF).

1. Position the ISA on the printer.

Figure 1-1724 Position the ISA on the printer

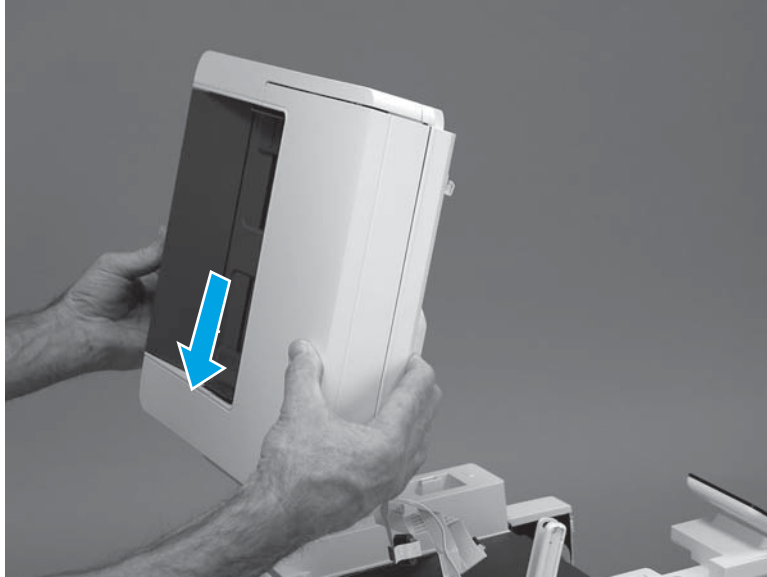

2. Engage the hinge pins on the ISA with the holders in the top cover (callouts 1/2), and then slide the ISA as shown to engage them

Figure 1-1725 Engage the hinge pins with the holders

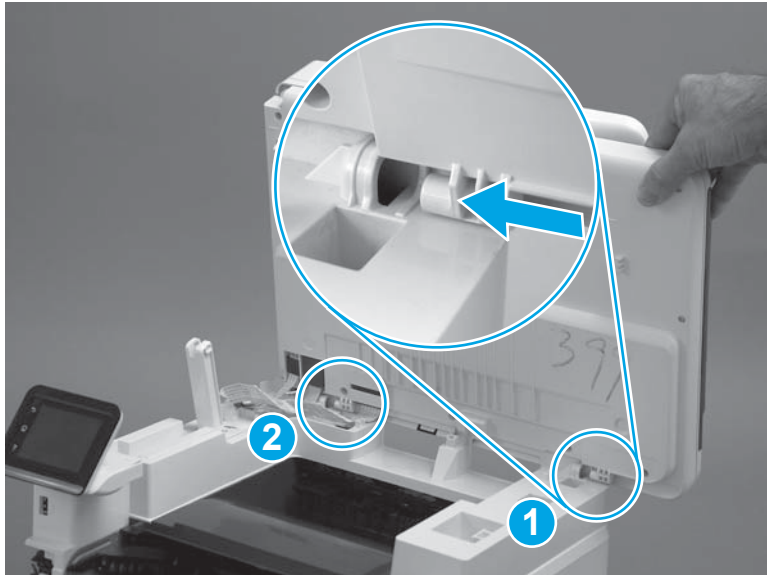

3. Rotate the ISA towards the front of the printer until it rests on the ISA lift assembly (callout 1).

Figure 1-1726 Rotate the ISA towards the front of the printer

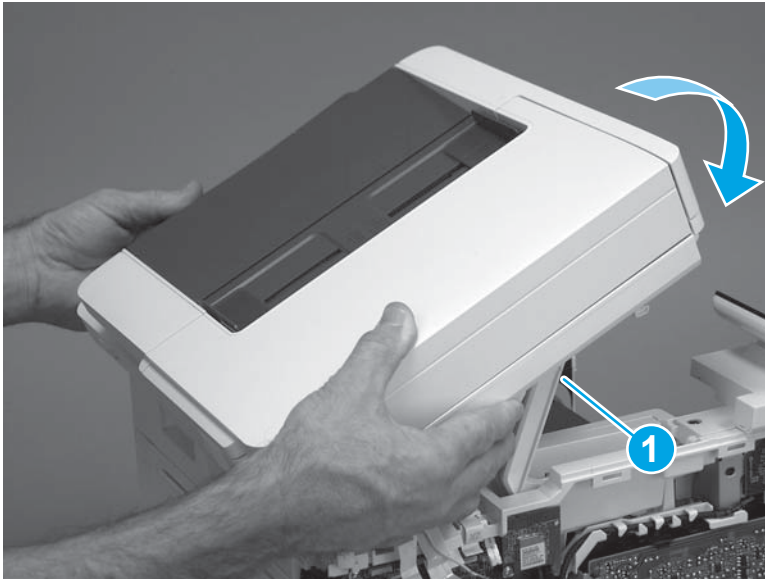

4. Pass the ground wire through the opening in the top cover.

Figure 1-1727 Pass the wire through the opening

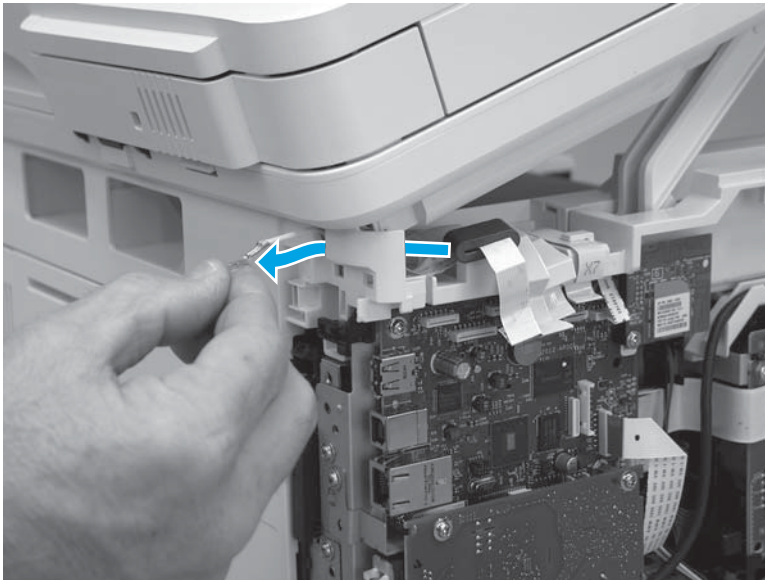

5. Install one screw (callout 1).

Figure 1-1728 Install one screw

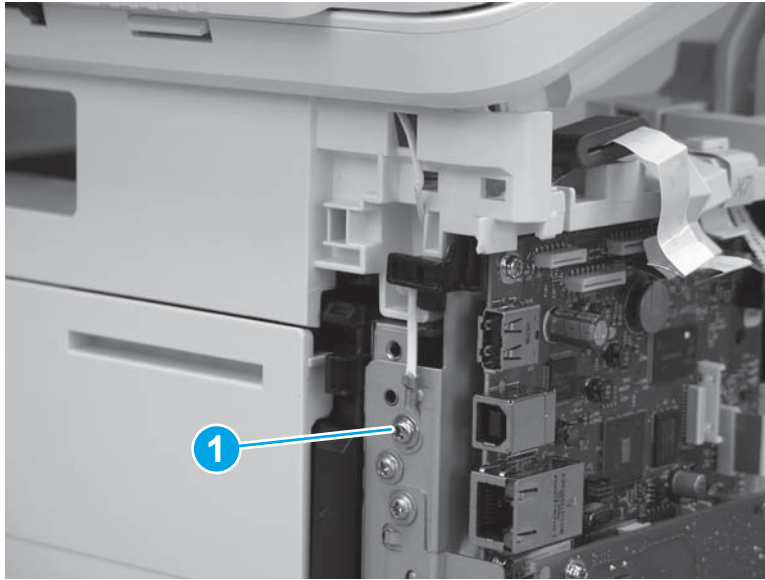

6. Install the ISA lift assembly slider pin.

 **Reinstallation tip:** Align the keyed portion of the locking pin with the slot and hole in the support arm.

Figure 1-1729 Install the slider pin



7. Rotate the slider pin (callout 1) towards the rear of the printer until the tab (callout 2) snap into place.

Figure 1-1730 Secure the slider pin

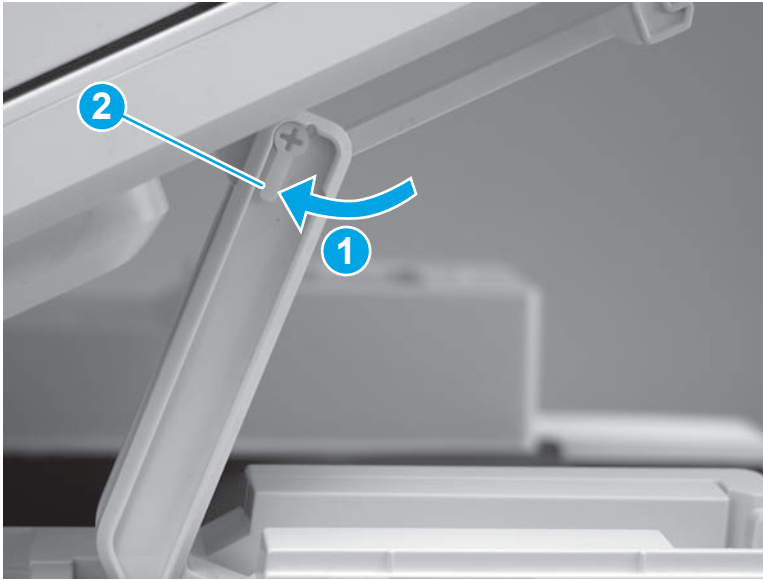

8. Install the ferrite (callout 1) in the holder, and then connect three FFCs (callout 2).

Figure 1-1731 Connect three FFCs

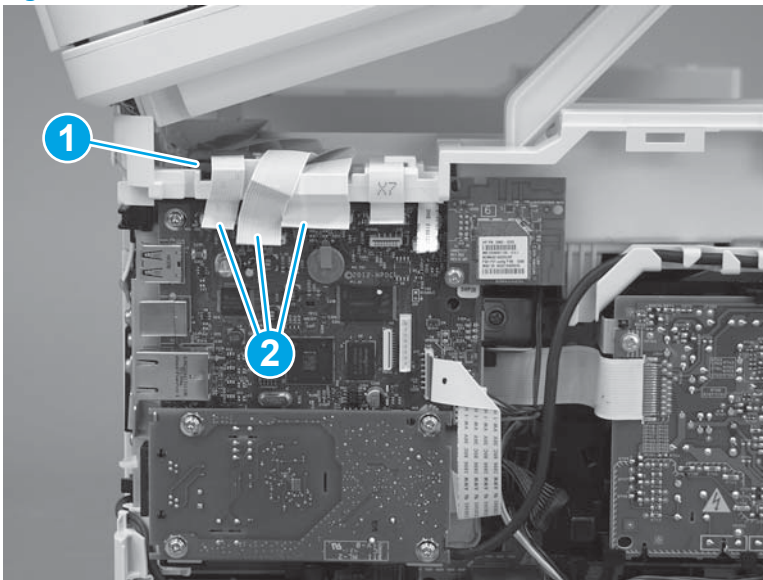

9. Position the rear edge of the ISA flat-flexible cable (FFC) cover on the printer (callout 1) , and then rotate it down (callout 2) until it snaps into place.

Figure 1-1732 Install the ISA FFC cover

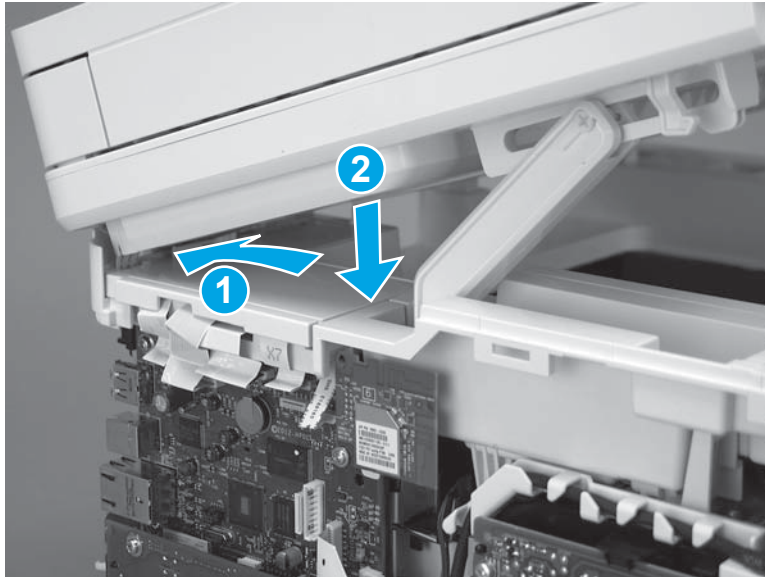

10. Lower the ISA.

Figure 1-1733 Lower the ISA

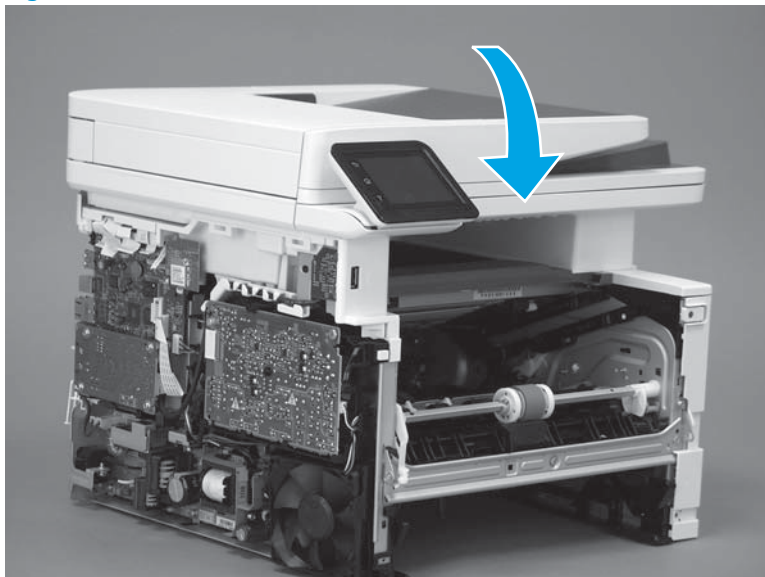

Step 22: Install the right cover

1. Position the cover (callout 1) on the printer, and then engage two bosses (callout 2).

Figure 1-1734 Install the cover

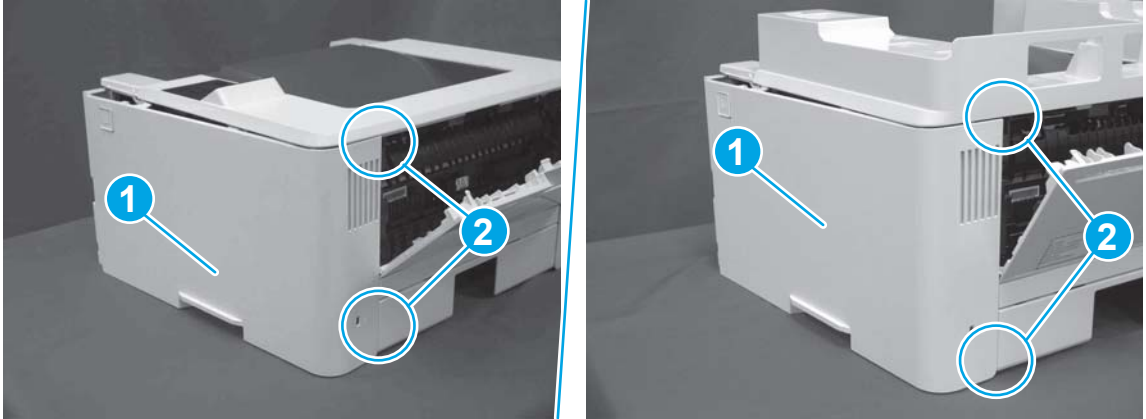

2. Rotate the front of the cover onto the printer (callout 1), engage three (callout 2) tabs, and then engage two bosses (callout 3).

Figure 1-1735 Engage two bosses and one tab

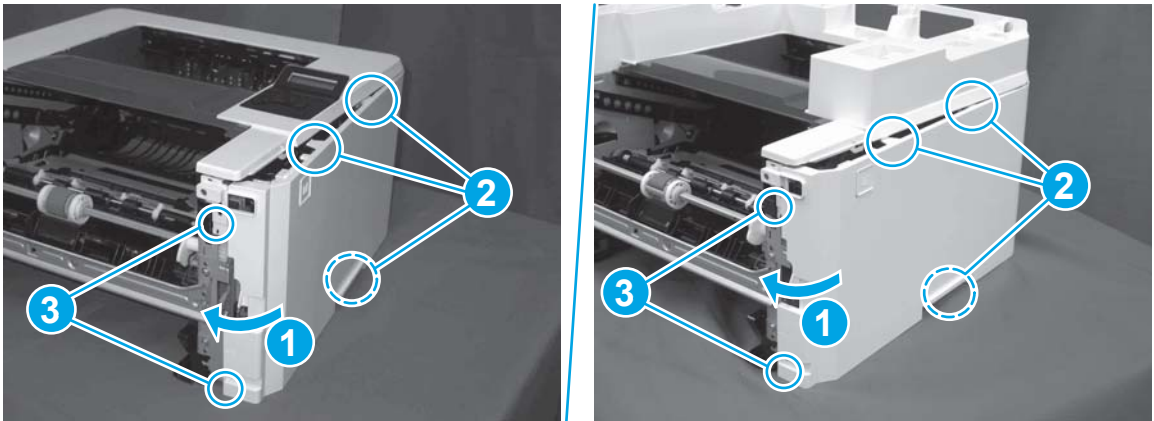

3. Make sure that the power switch (callout 1) and cartridge door assembly button (callout 2) correctly function.

 **NOTE:** Remove, and then reinstall the cover if the switch or button does not correctly function.

Figure 1-1736 Check the power switch and cartridge door assembly button



4. Install one screw (callout 1).

Figure 1-1737 Install one screw

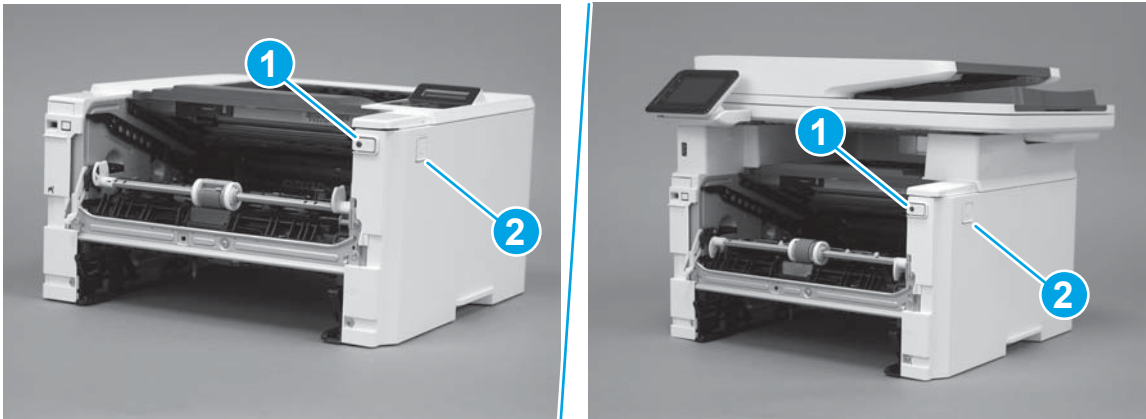

Step 23: Install the left cover

1. At the front of the printer, do one of the following:
 - **M403/M402:** Position the cover on the printer (callout 1), and then engage two bosses (callout 2).
 - **M427/M426:** Position the cover on the printer (callout 3), engage one tab (callout 4), and then engage two bosses (callout 4).

Figure 1-1738 Install the cover

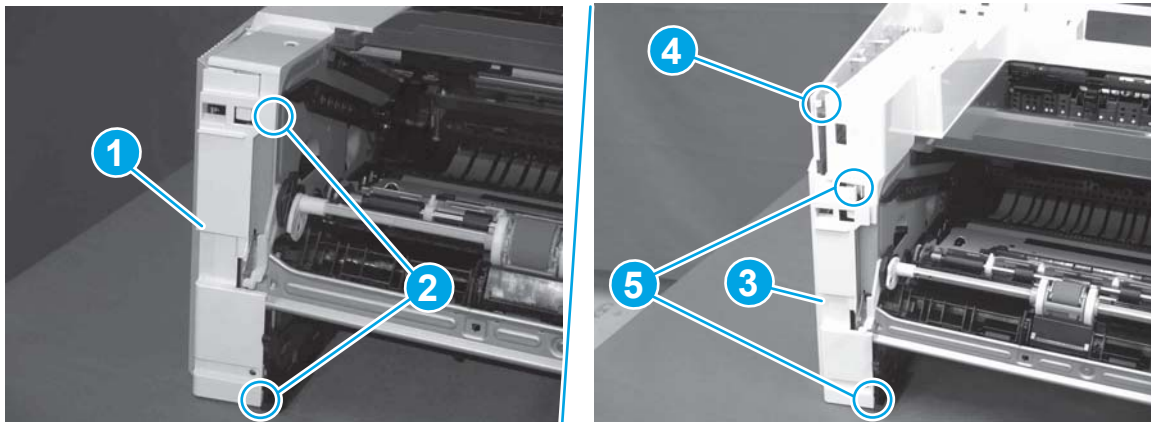

- Carefully rotate the rear of the cover onto the printer (callout 1), engage three tabs (callout 2), and then engage two bosses (callout 3).

Figure 1-1739 Engage three tabs and two bosses

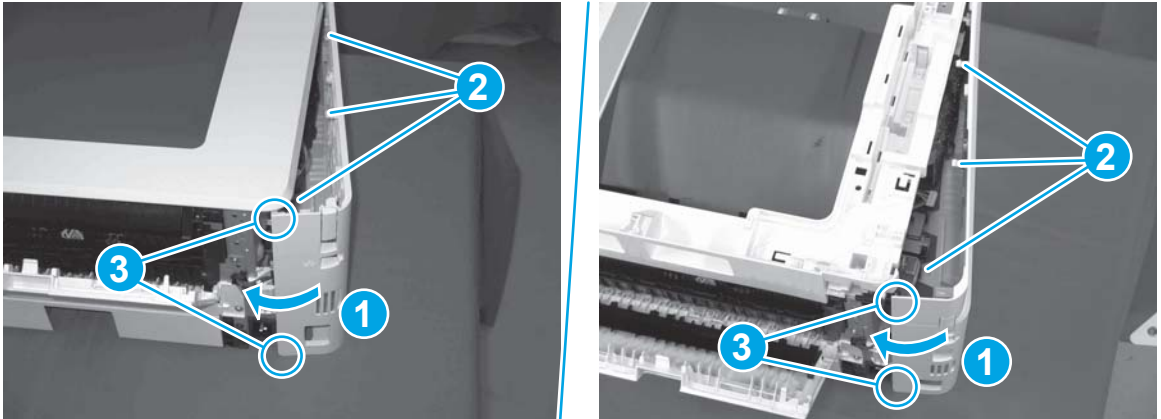

- Install one screw (callout 1).

Figure 1-1740 Install one screw

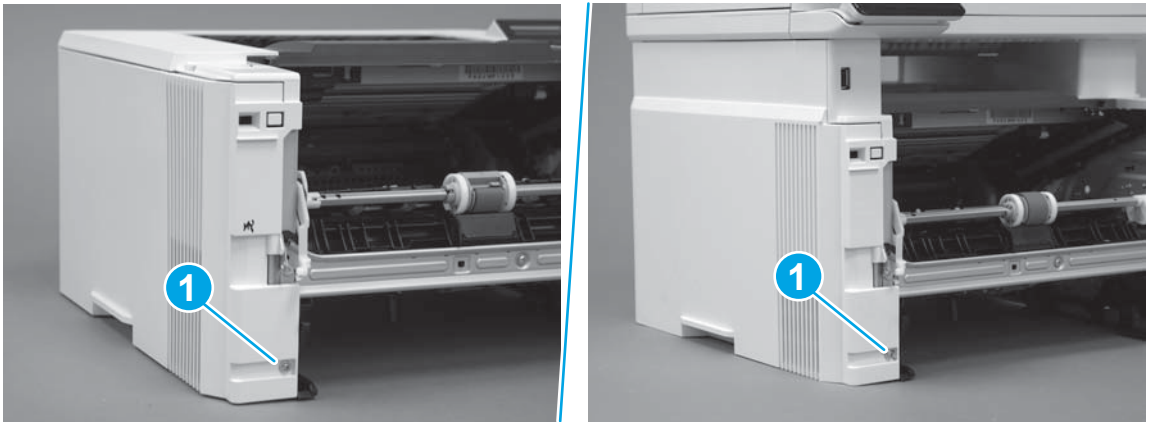

Step 24: Install the cartridge door assembly

 **Reinstallation tip:** After a replacement door is installed, make sure to install the nameplate (supplied in the kit) corresponding to the printer name on the door.

- Position the door close to the printer, and then engage the keyed pin on the left-side retainer arm with the hole in the door.

Figure 1-1741 Engage the left-side retainer arm

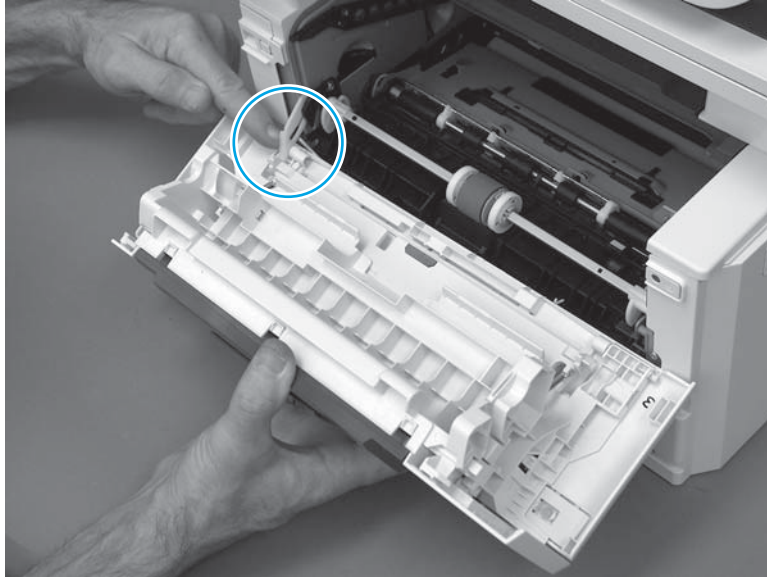

2. Engage the right-side door hinge pin with the hole in the chassis (callout 1).

Figure 1-1742 Install the door

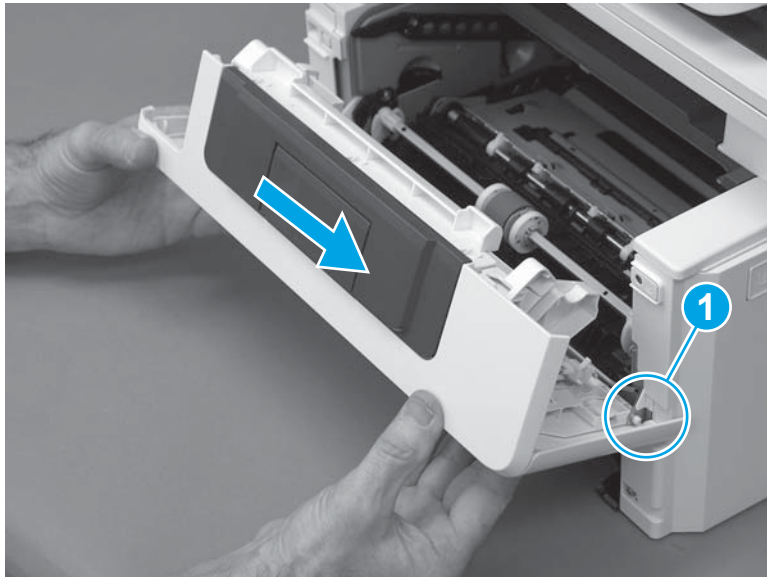

3. Install the link (callout 1).

 **IMPORTANT:** Make sure that the link snaps into place on the arm (callout 2). The link actuates the fuser pressure-release mechanism.

Figure 1-1743 Install the pressure-release link

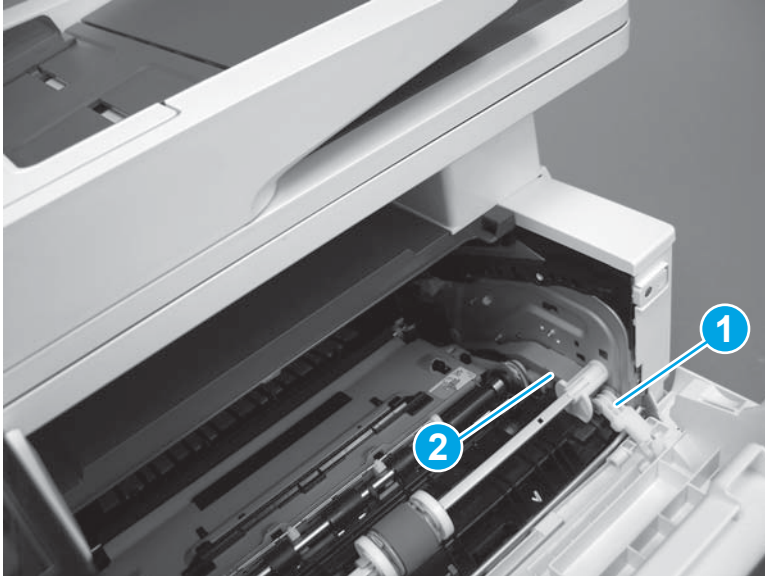

4. Slide the guide into the printer (callout 1), and then make sure that the tab (callout 2) snaps into place to secure the guide to the chassis.

Figure 1-1744 Install the guide

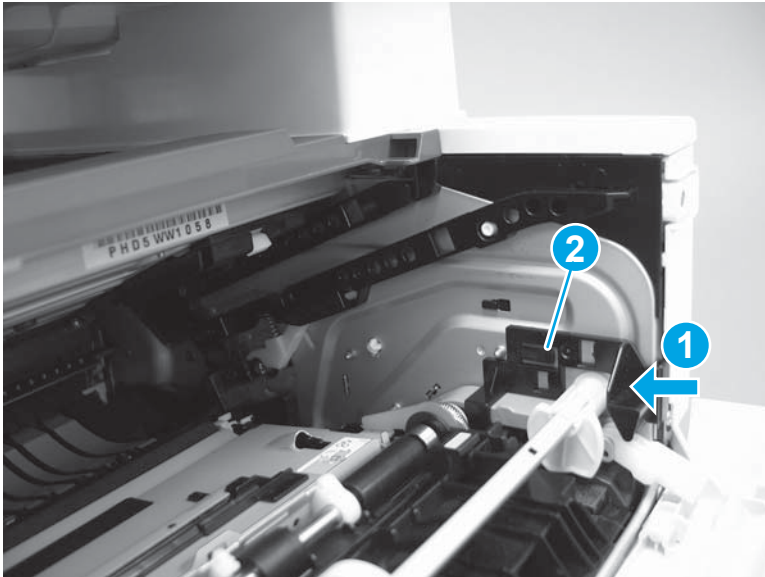

5. Position the shaft on the door, and then align the left-side hinge on the door with the hole in the chassis (callout 1).

Figure 1-1745 Align the hinge

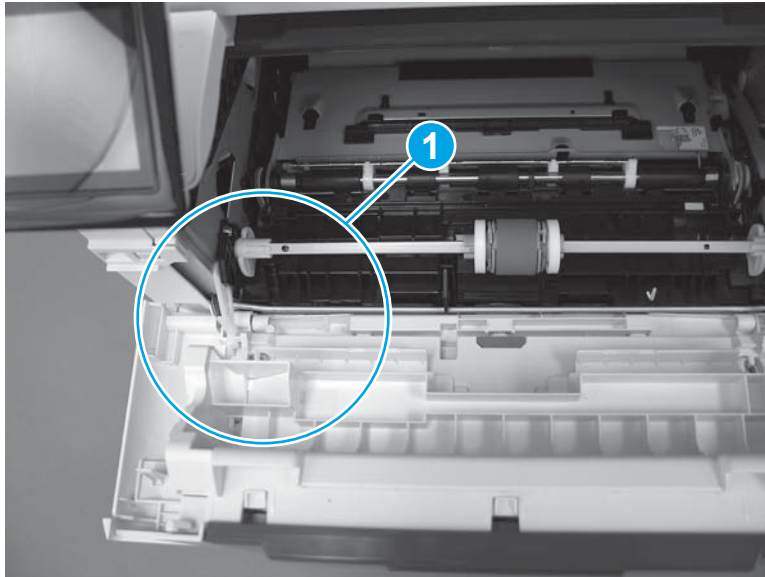

6. Push the shaft towards the left side of the printer to install it (callout 1).

 **Reinstallation tip:** Make sure that the support shaft is fully installed and correctly orientated (callout 2) so that it will not interfere with the door opening and closing.

Figure 1-1746 Install the support shaft



Step 25: Install Tray 2

- ▲ Slide the tray straight into the printer to install it.

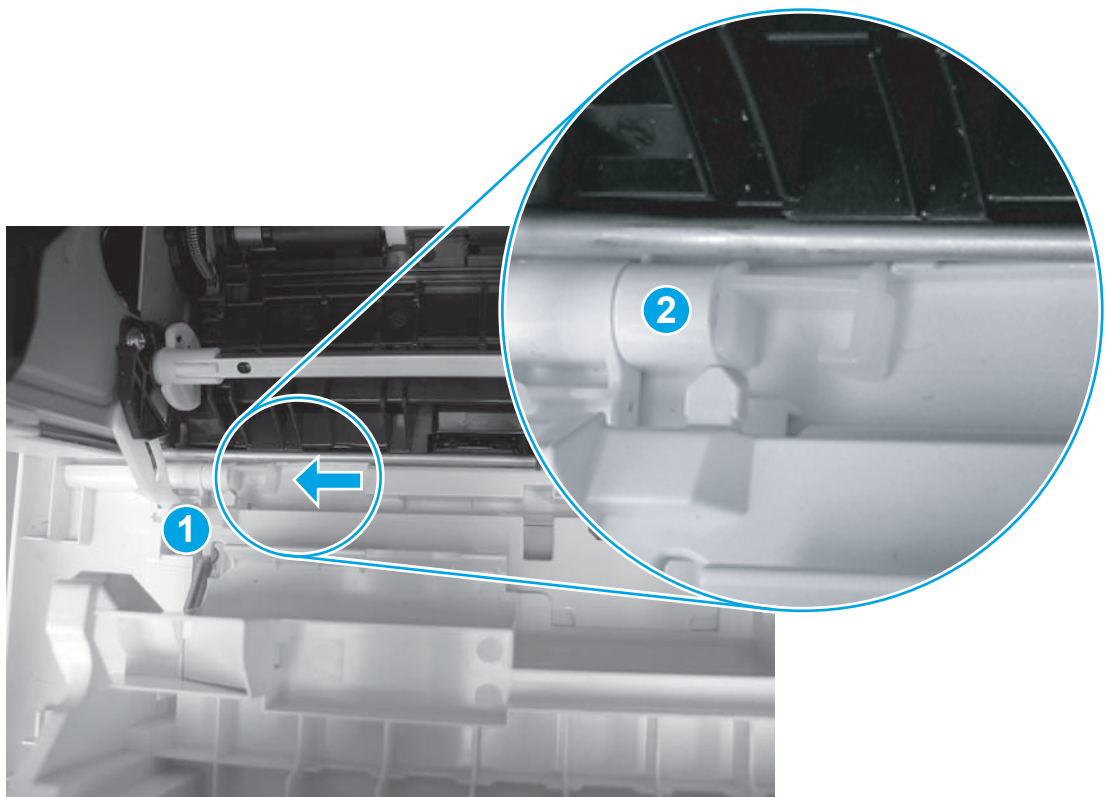
Figure 1-1747 Install the tray



Removal and replacement: High-voltage power supply

- [Introduction](#)
- [Step 1: Remove Tray 2](#)
- [Step 2: Remove the cartridge door assembly](#)
- [Step 3: Remove the left cover](#)
- [Step 4: Remove the right cover](#)
- [Step 5: Remove the integrated scanner assembly \(M427/M246\)](#)
- [Step 6: Remove the control panel \(M427/M246\)](#)
- [Step 7: Remove the top cover \(M427/M426\)](#)
- [Step 8: Remove the top cover \(M403/M402\)](#)
- [Step 9: Remove the paper delivery tray \(output bin\)](#)
- [Step 10: Remove the sheet-metal formatter bracket and formatter PCA](#)
- [Step 11: Remove the HVPS](#)
- [Step 12: Unpack the replacement assembly](#)
- [Step 13: Install the HVPS](#)
- [Step 14: Install the sheet-metal formatter bracket and formatter PCA](#)
- [Step 15: Install the paper delivery tray \(output bin\)](#)
- [Step 16: Install the top cover \(M403/M402\)](#)
- [Step 17: Install the top cover \(M427/M426\)](#)
- [Step 18: Install the control panel \(M427/M246\)](#)
- [Step 19: Install the integrated scanner assembly \(M427/M246\)](#)
- [Step 20: Install the right cover](#)
- [Step 21: Install the left cover](#)
- [Step 22: Install the cartridge door assembly](#)
- [Step 23: Install Tray 2](#)

Introduction

This document provides the procedures to remove and replace the high-voltage power supply (HVPS).

Before performing service

Turn the printer power off

- Disconnect the power cable.

⚠ WARNING! To avoid damage to the printer, turn the printer off, wait 30 seconds, and then remove the power cable before attempting to service the printer.

Use the table below to identify the correct part number for your printer. To order the part, go to www.hp.com/buy/parts.

High-voltage power supply (HVPS) part number	
RM2-7508-000CN	High-voltage power supply (HVPS)

Required tools

- #2 Phillips screwdriver with a magnetic tip.

After performing service

Turn the printer power on

- Connect the power cable.
- Use the power switch to turn the power on.

Post service test

Make sure that the printer initializes to a **Ready** state.

Print a configuration page to make sure that the printer is functioning correctly.

Step 1: Remove Tray 2

- ▲ Pull the tray straight out of the printer to remove it.

Figure 1-1748 Remove the tray



Step 2: Remove the cartridge door assembly

 **NOTE:** If the toner cartridge was not removed prior to servicing the printer, remove it now.

1. Release one tab (callout 1), and then slide shaft (callout 2) in the direction the arrow indicates and remove it.

 **TIP:** It might be easier to release the support shaft by using a small flat-blade screwdriver.

Figure 1-1749 Release the support shaft

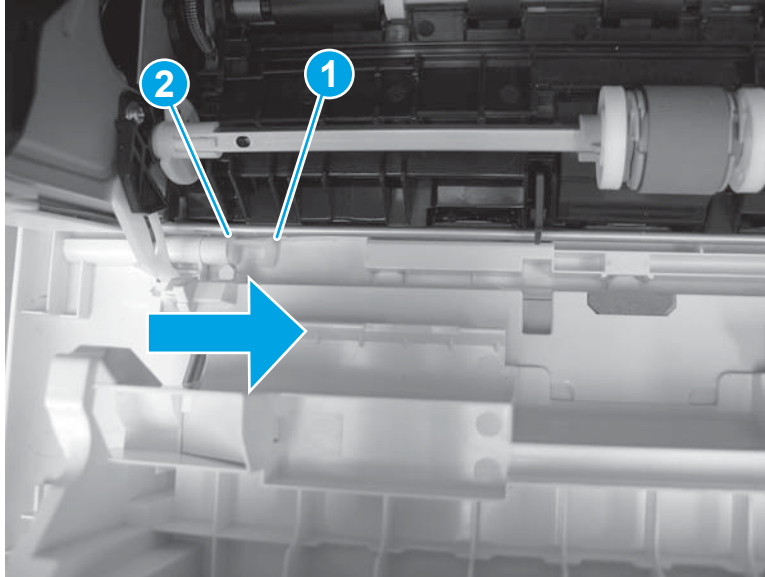

2. Release one tab (callout 1), and then slide the guide (callout 2) in the direction the arrow indicates and remove it.

Figure 1-1750 Remove the guide

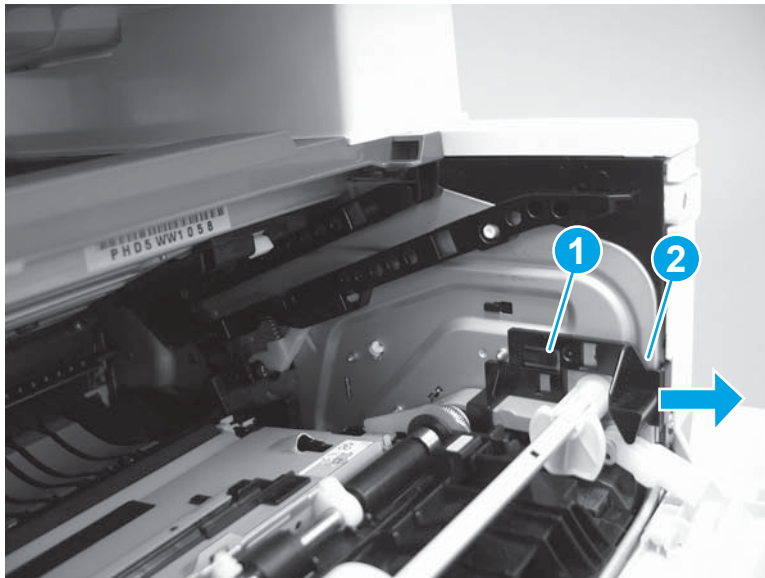

3. Remove the link arm (callout 1).

Figure 1-1751 Remove the link arm

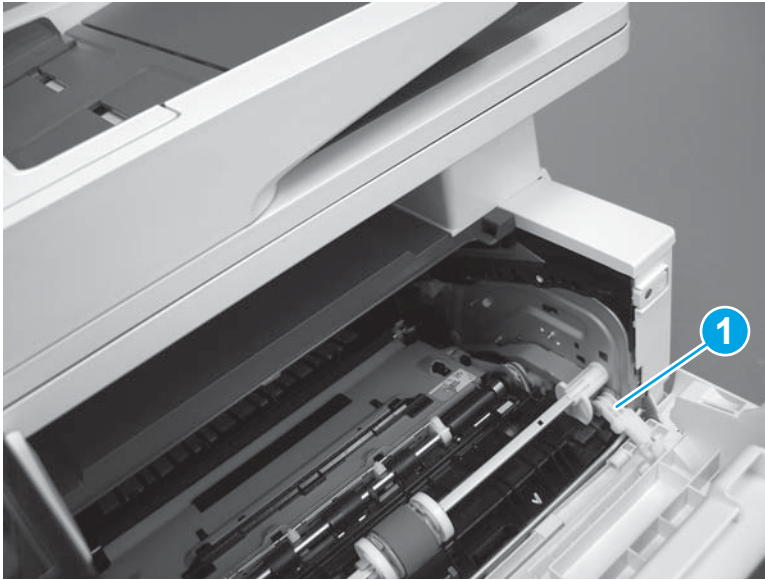

4. Slide the cartridge door assembly (callout 1) in the direction the arrow indicates and remove it.

Figure 1-1752 Remove the door

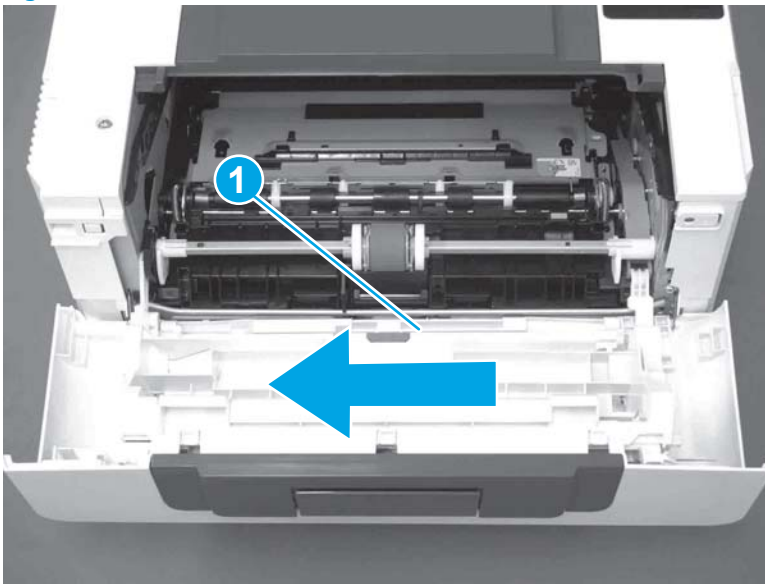

5. Remove the link (callout 1) from the cartridge door assembly (callout 2).

Figure 1-1753 Release the left-side retainer arm

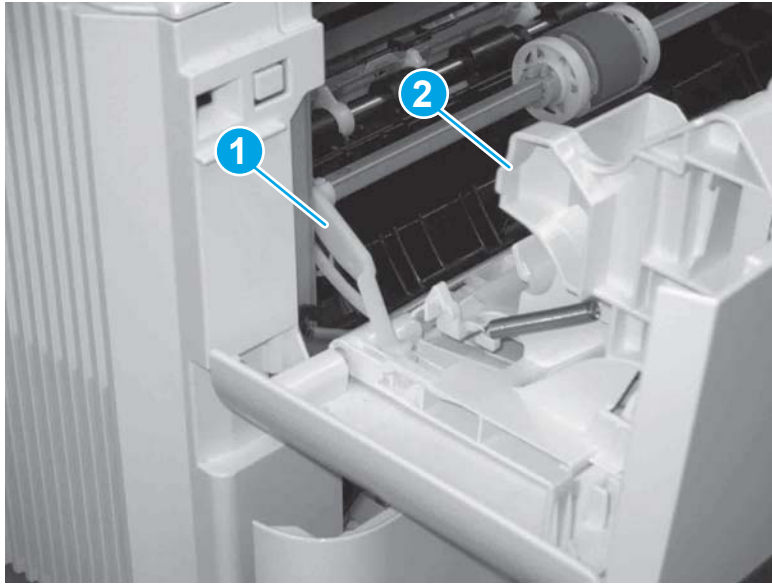

Step 3: Remove the left cover

1. Remove one screw (callout 1).

Figure 1-1754 Remove one screw

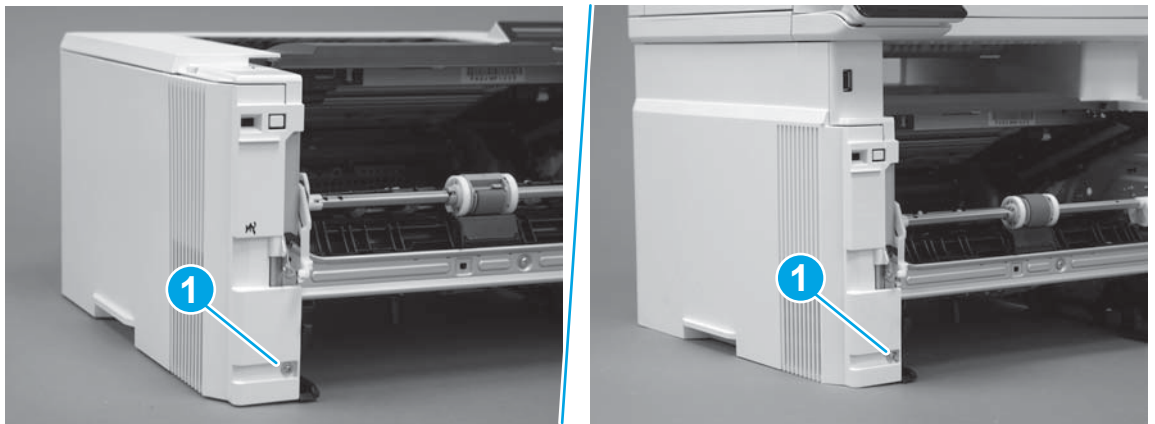

2. Open the rear door, release two bosses (callout 1), and then release three tabs (callout 2).

Figure 1-1755 Release two bosses and three tabs

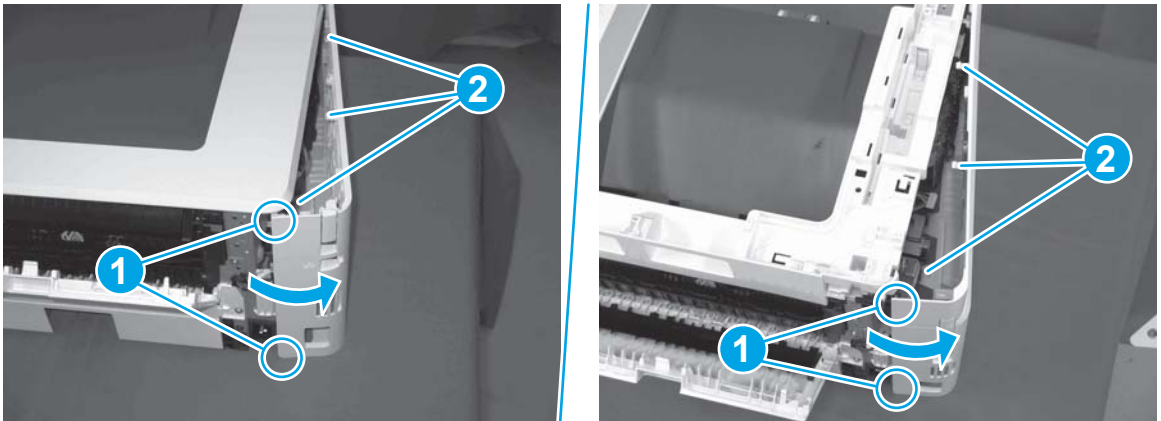

3. At the front of the printer, do one of the following:
 - **M403/M402:** Release two bosses (callout 1), and then remove the cover (callout 2).
 - **M427/M426:** Release one tab (callout 3), two bosses (callout 4), and then remove the cover (callout 5).

CAUTION: Be careful when releasing the upper bosses on the M427/M426 cover. One portion of the cover (callout 6) is fragile and is easily broken.

Figure 1-1756 Remove the cover

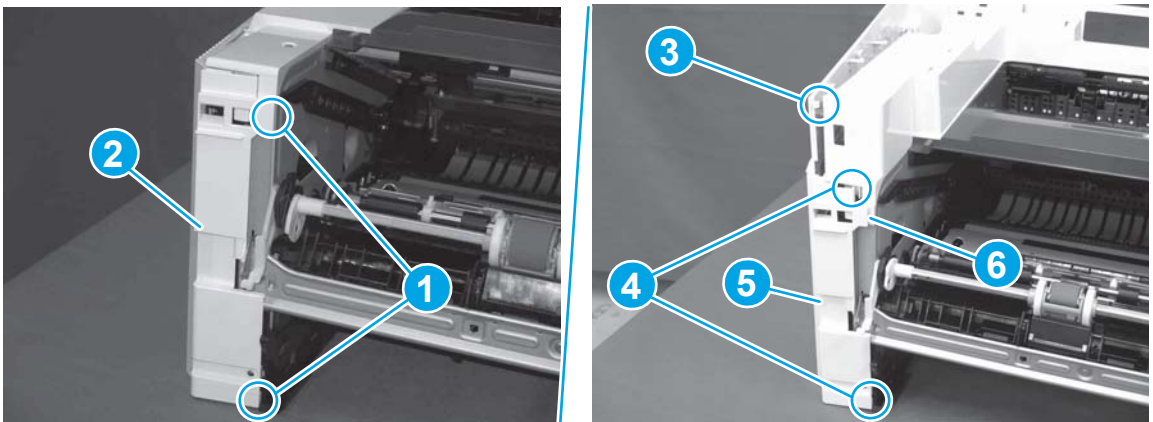

Step 4: Remove the right cover

1. Remove one screw (callout 1).

Figure 1-1757 Remove one screw

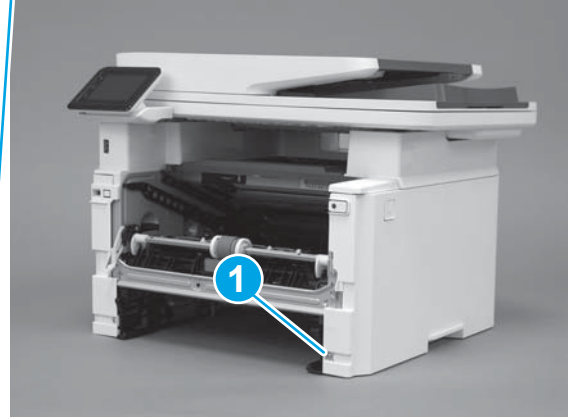
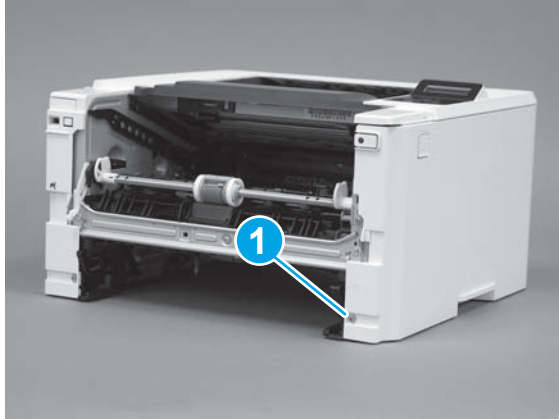

2. At the front of the printer, release two bosses (callout 1), and then release three tabs (callout 2).

Figure 1-1758 Release two bosses and three tabs

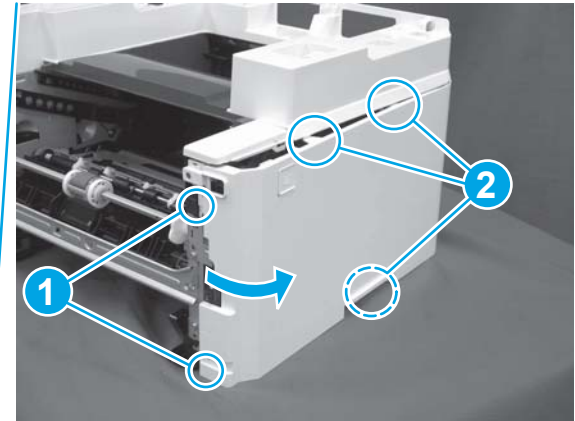
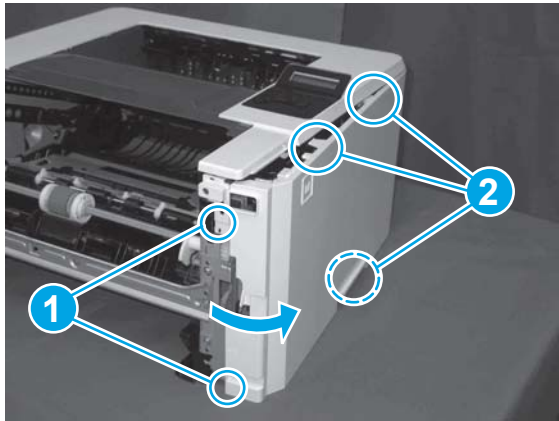

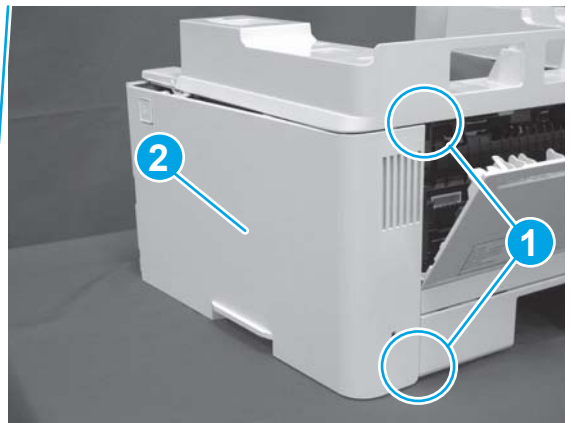
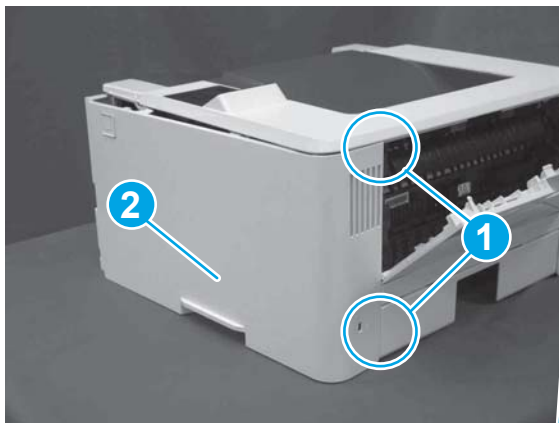

3. Open the rear door, release two bosses (callout 1), and then remove the cover (callout 2).

Figure 1-1759 Remove the cover



Step 5: Remove the integrated scanner assembly (M427/M246)

 **NOTE:** The step is for the M427/M426 printer. For the M403/M402, skip this step and go to [Step 8: Remove the top cover \(M403/M402\)](#) on page 943.

 **NOTE:** M427/M426 models only. The integrated scanner assembly (ISA) includes the sub-scanner assembly (SSA) and the automatic document feeder (ADF).

1. Raise the ISA.

Figure 1-1760 Raise the ISA

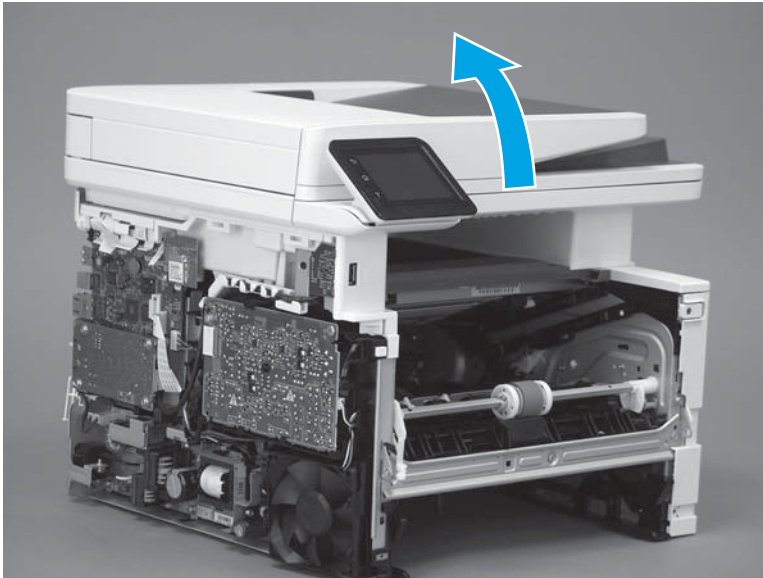

2. Release the ISA flat-flexible cable (FFC) cover (callout 1), and then remove it (callout 2).

Figure 1-1761 Remove the ISA FFC cover

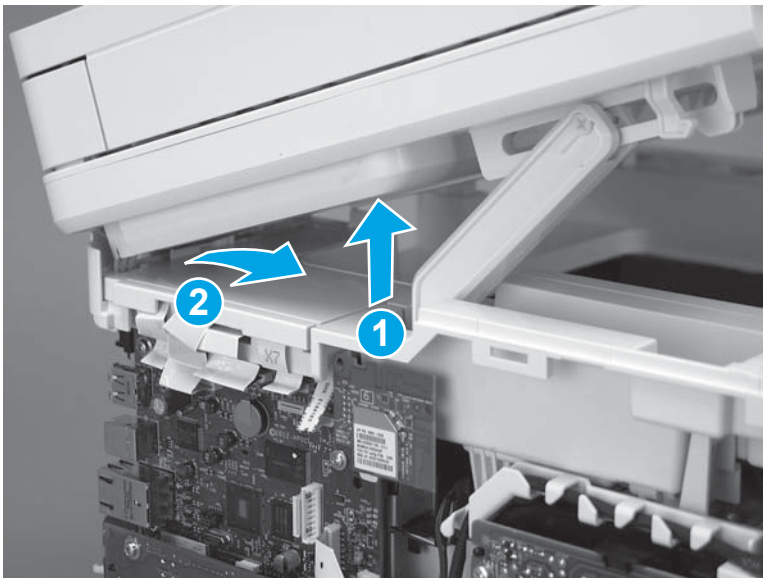

3. Disconnect three FFCs (callout 1), and then remove the ferrite (callout 2) from the holder.

CAUTION: The ferrite is not captive on the FFC. Do not lose the ferrite while handling the ISA.

Figure 1-1762 Disconnect three FFCs

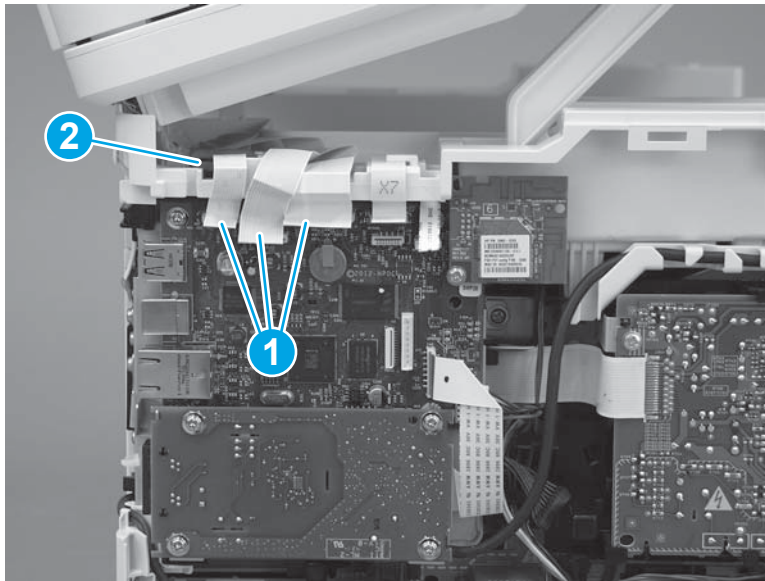

4. Remove one screw (callout 1).

Figure 1-1763 Remove one screw

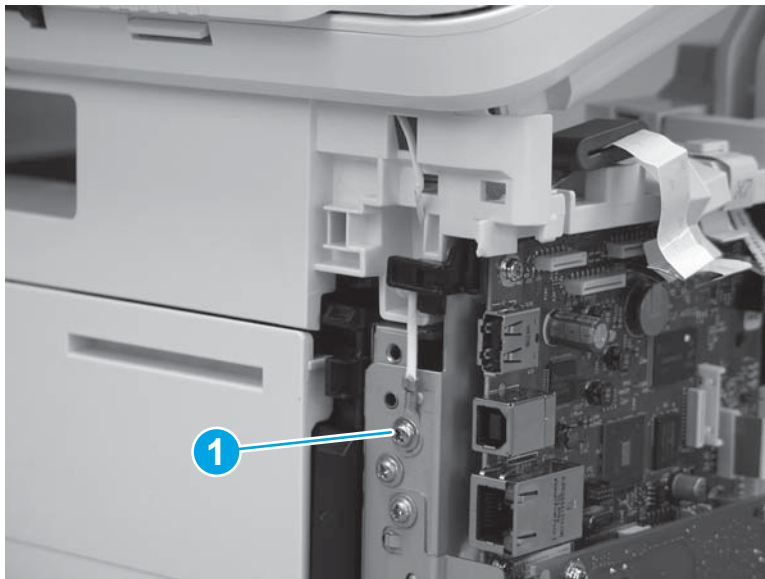

5. Pass the ground wire through the opening in the top cover.

Figure 1-1764 Pass the wire through the opening

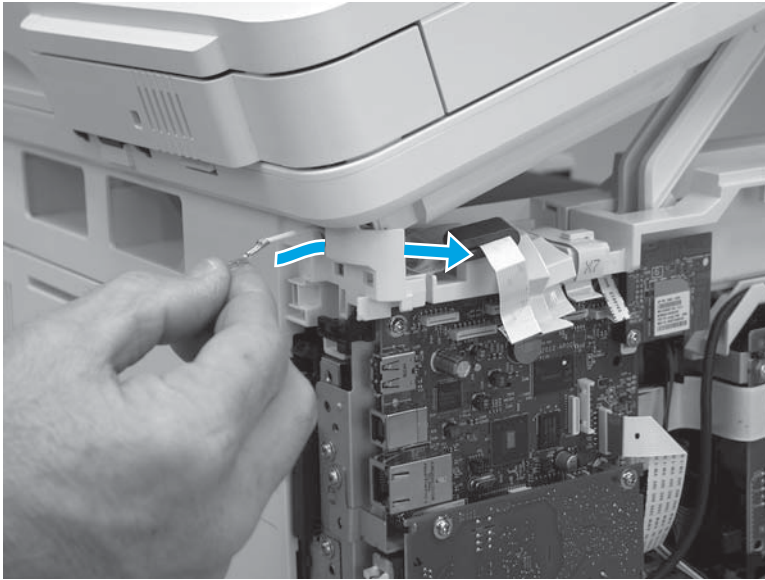

6. Release one tab (callout 1), and then rotate the ISA slider pin (callout 2) towards the front of the printer to release it.

Figure 1-1765 Release one tab and rotate the slider pin

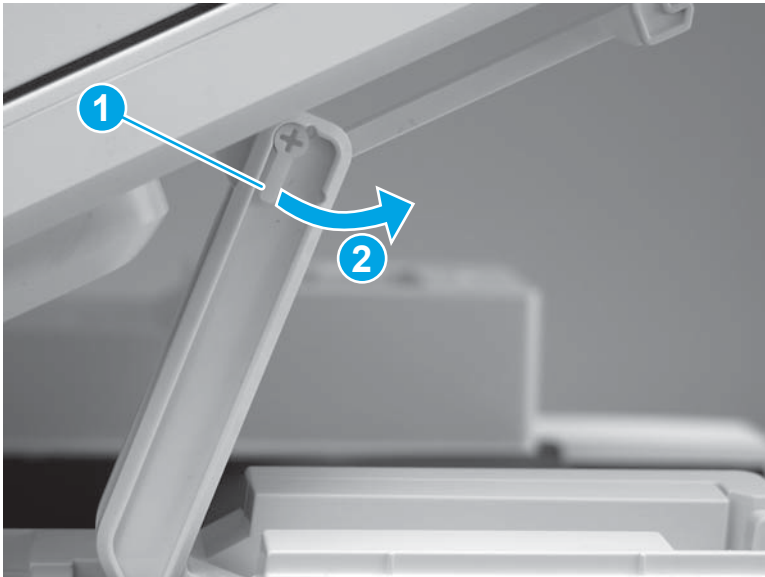

7. Remove the slider pin.

Figure 1-1766 Remove the slider pin

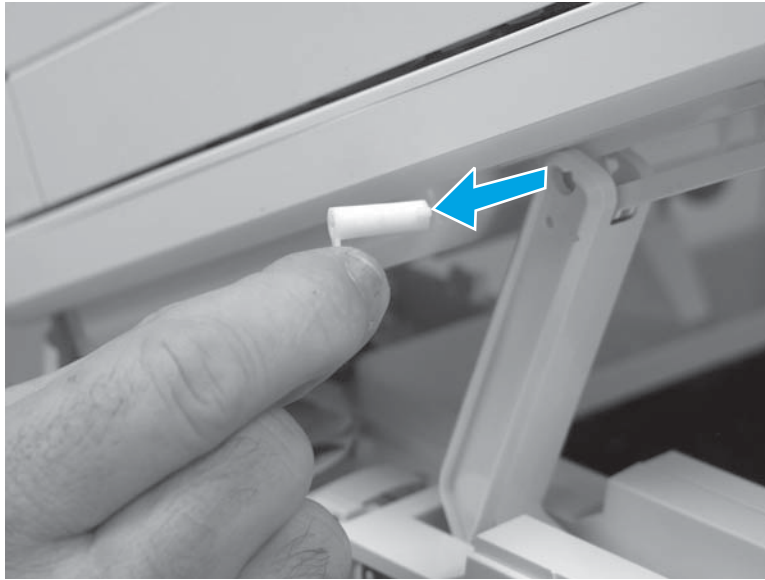

8. Rotate the ISA towards the rear of the printer until it stops.

Figure 1-1767 Rotate the ISA towards the rear of the printer



- Slide the ISA as shown to release it.

Figure 1-1768 Release the ISA

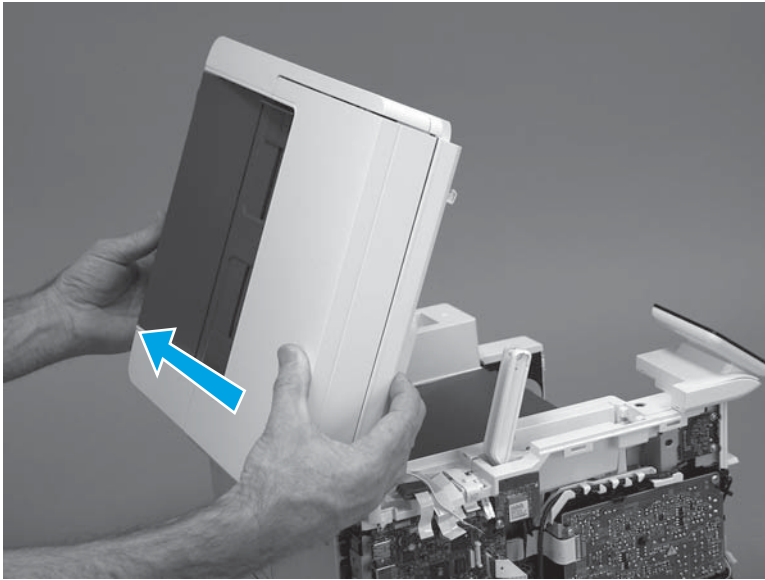

- Remove the ISA.

Figure 1-1769 Remove the ISA

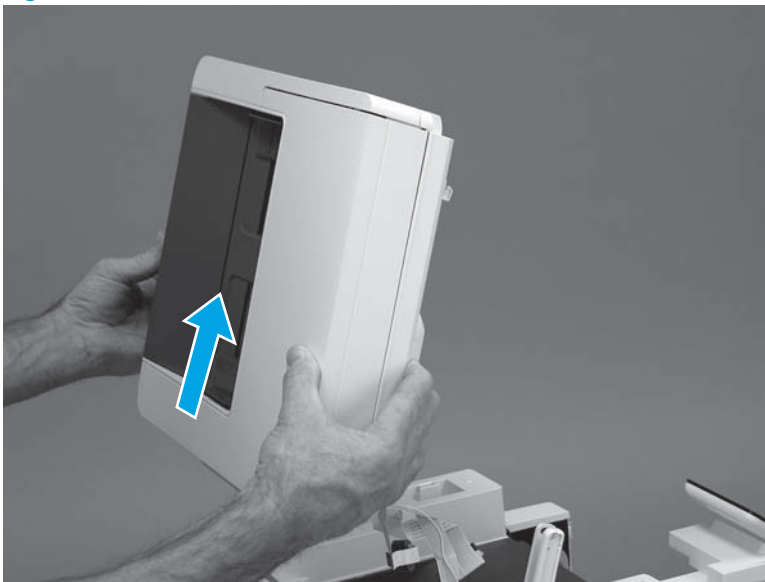

Step 6: Remove the control panel (M427/M246)



NOTE: The step is for the M427/M426 printer. For the M403/M402, skip this step and go to [Step 8: Remove the top cover \(M403/M402\) on page 943](#).

- Disconnect one FFC (callout 1; J114), and then release the FFC from the retainer (callout 2).

Figure 1-1770 Disconnect one connector

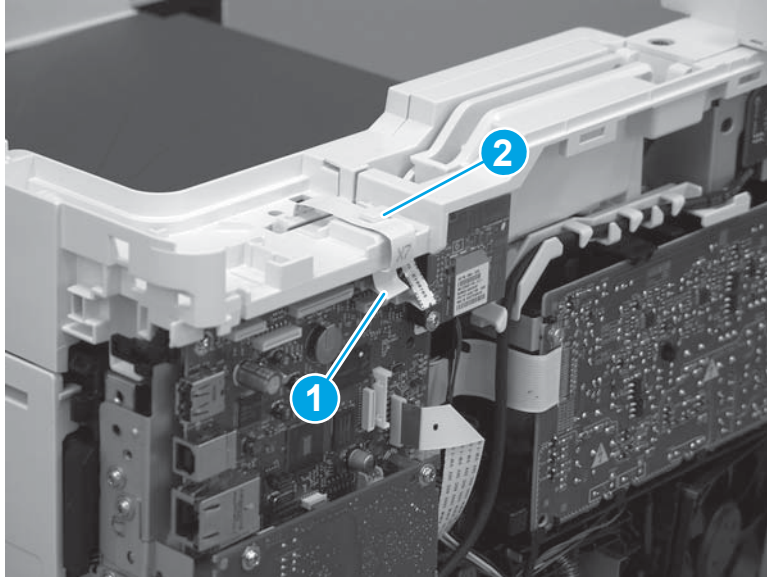

2. Remove one screw (callout 1).

Figure 1-1771 Remove one screw

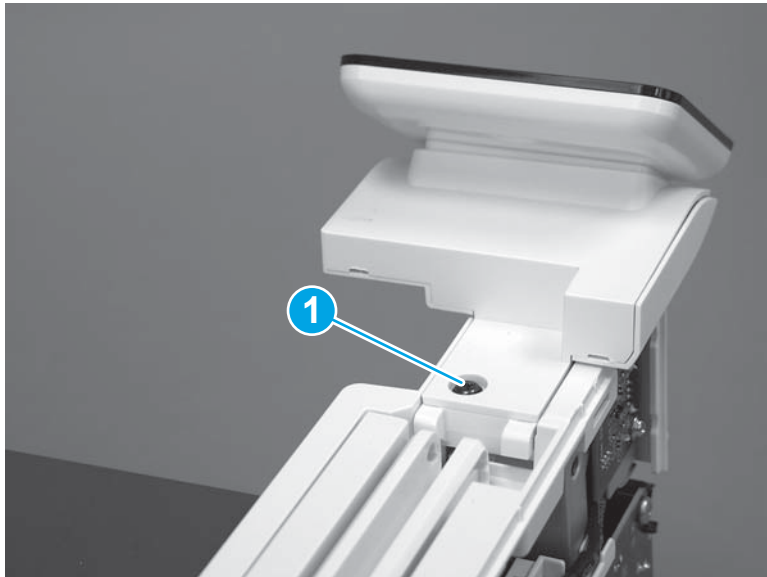

3. Use a small flat-blade screwdriver to release two tabs (callout 1) on the control-panel cable cover.

Figure 1-1772 Release two tabs

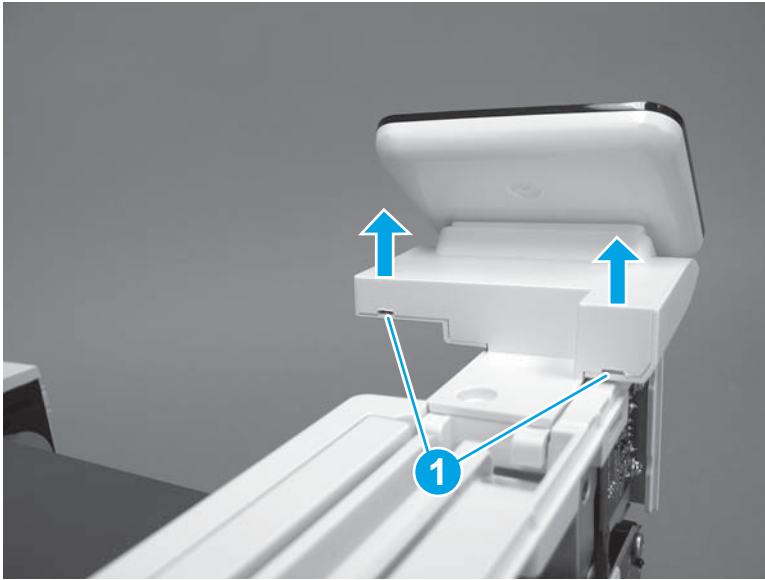

4. Remove the control-panel cable cover.

Figure 1-1773 Remove the cover

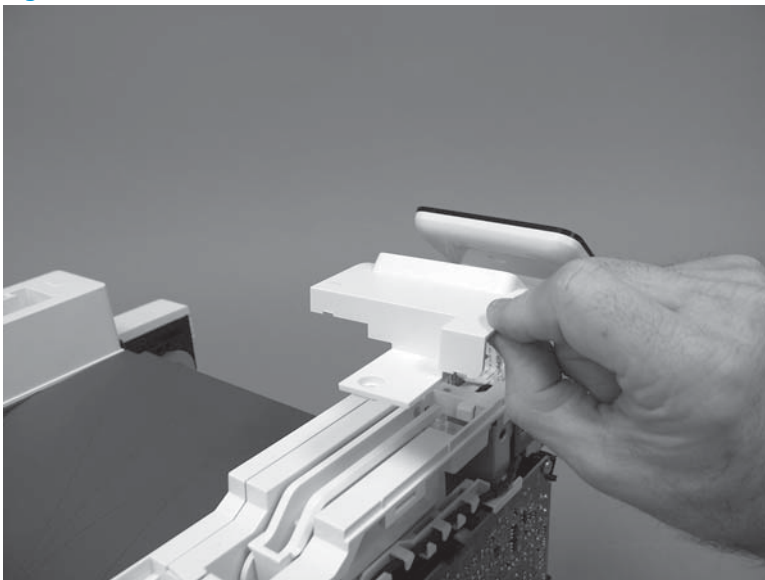

5. Remove one grounding screw (callout 1), and then move the ground cable (callout 2) out of the way.

Figure 1-1774 Remove one screw

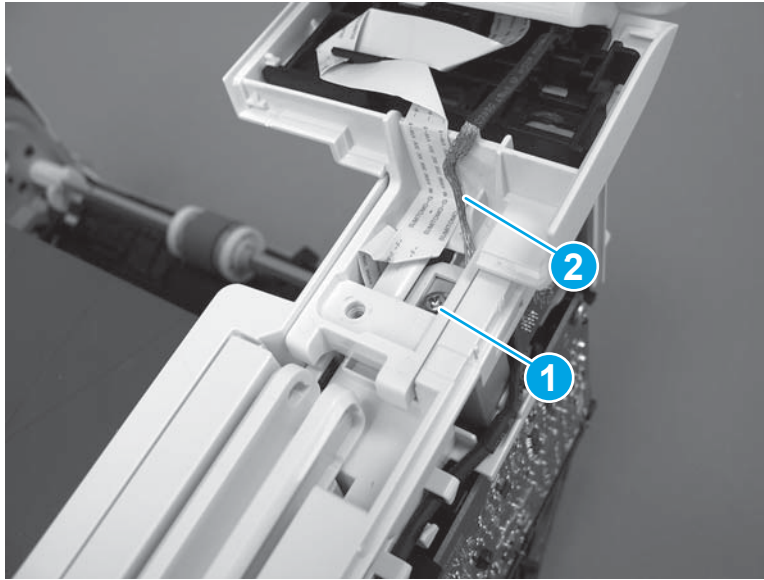

6. Move the FFC out of the way, and then remove two screws (callout 1).

Figure 1-1775 Remove two screws

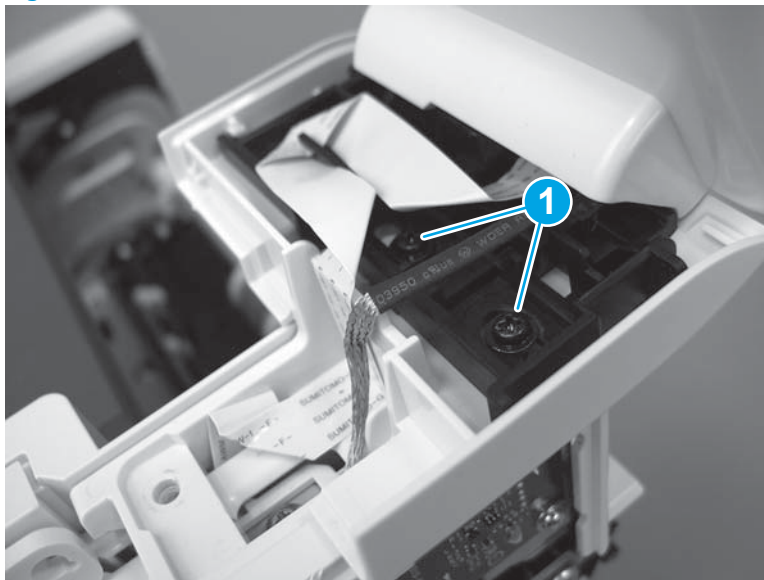

7. Slightly lift up the control-panel assembly to separate it from the top cover.

⚠ CAUTION: The control panel assembly is still connected to the printer by the FFC. Do not attempt to completely remove the assembly.

Figure 1-1776 Lift up the control-panel assembly

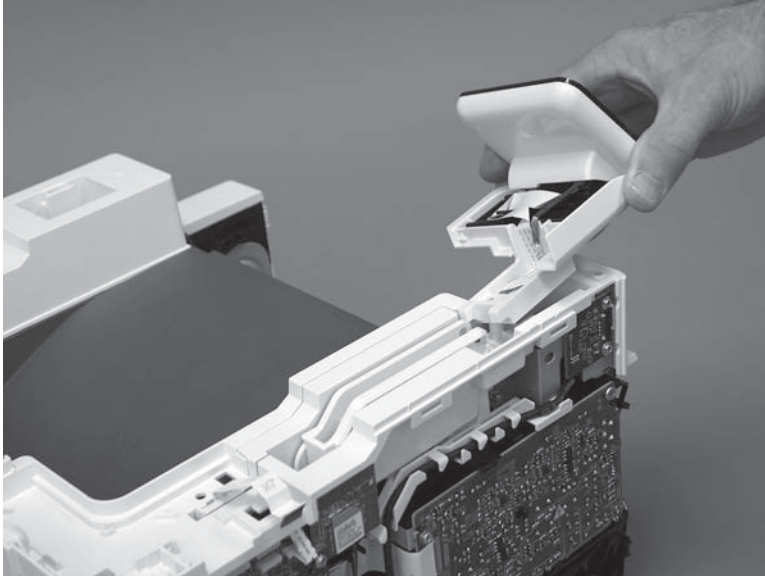

8. Lift up the control-panel FFC cover to remove the control-panel assembly.

Figure 1-1777 Remove the control-panel assembly

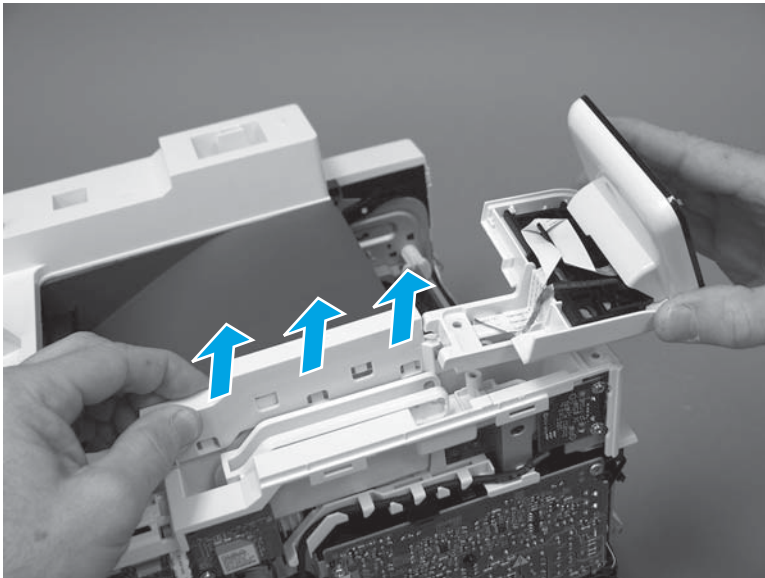

Step 7: Remove the top cover (M427/M426)

📝 NOTE: The step is for the M427/M426 printer. For the M403/M402, skip this step and go to [Step 8: Remove the top cover \(M403/M402\) on page 943](#).

1. Release the USB cable (callout 1) from the cable guide.

Figure 1-1778 Remove the USB cable

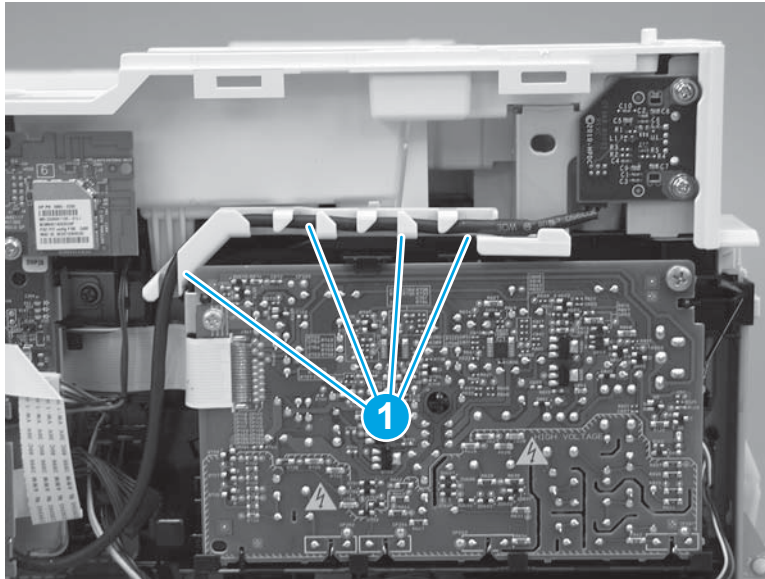

2. Remove five screws (callout 1), release four bosses (callout 2), and then remove the top cover (callout 3).

Figure 1-1779 Remove the cover

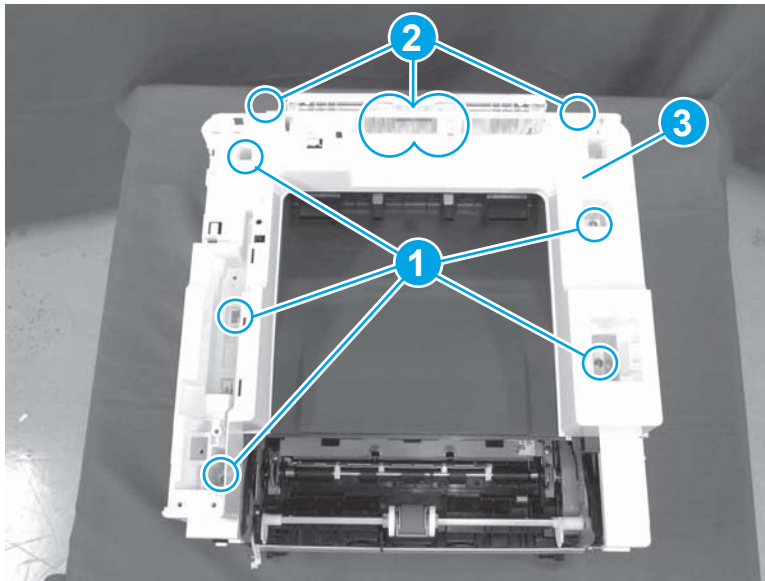

Step 8: Remove the top cover (M403/M402)

 **NOTE:** The step is for the M403/M402 printer. For the M427/M426, skip this step and go to [Step 9: Remove the paper delivery tray \(output bin\) on page 945.](#)

1. Remove one screw (callout 1).

Figure 1-1780 Remove one screw



2. At the right side of the printer, release the one boss (callout 1), and then release one tab (callout 2).

Figure 1-1781 Release one boss and one tab

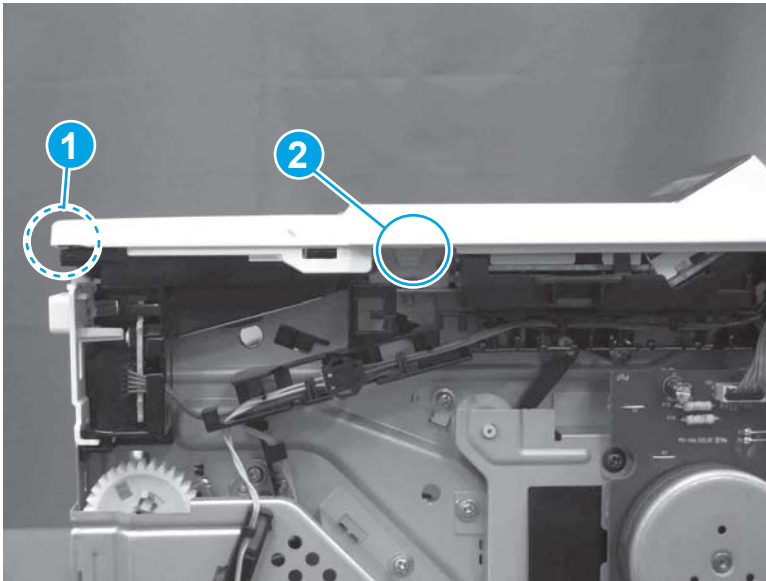

3. Release four tabs (callout 1), release four bosses (callout 2), and then remove the top cover (callout 3).



 **TIP:** Open the rear door to make releasing the bosses (callout 3) easier.

Figure 1-1782 Remove the cover

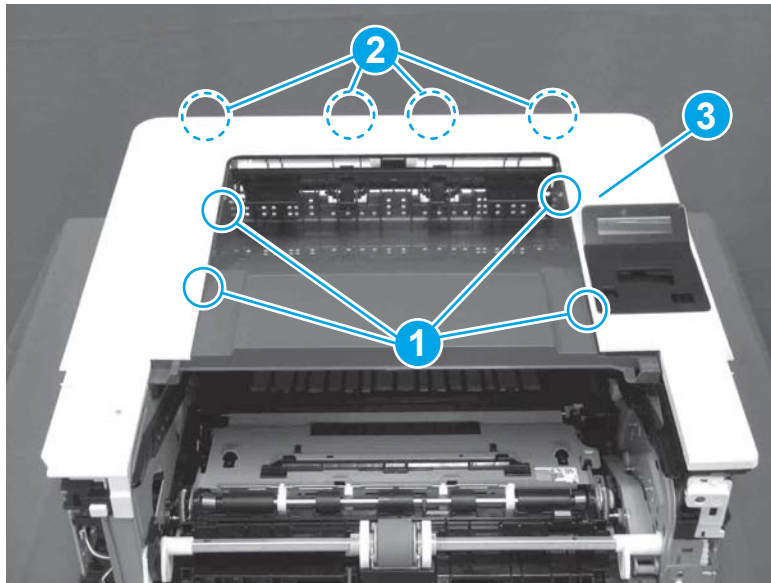

Step 9: Remove the paper delivery tray (output bin)

 **NOTE:** This procedure shows the M403/M402 model, however, the paper delivery tray (output bin) removal is similar for the M427/M426 printer.

- ▲ Release two bosses (callout 1), release two tabs (callout 2), and then remove the paper delivery tray (output bin; callout 3).

Figure 1-1783 Release two tabs

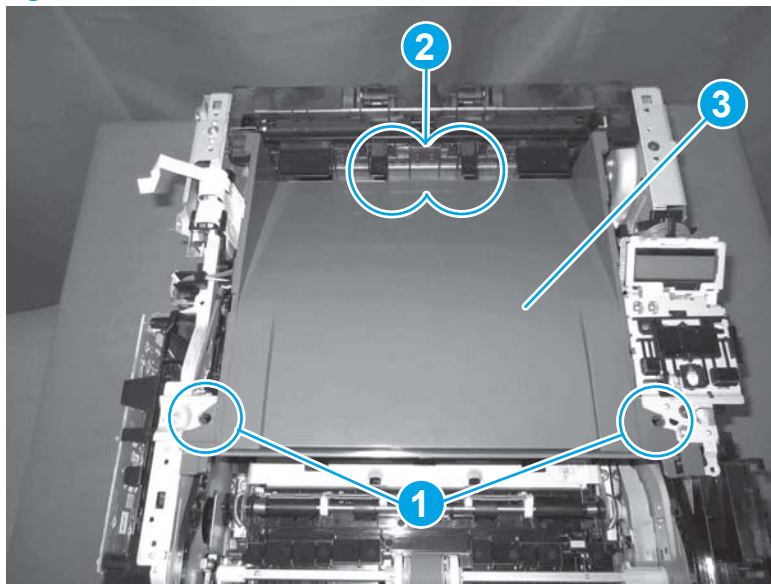

Step 10: Remove the sheet-metal formatter bracket and formatter PCA

 **NOTE:** Disconnect any remaining formatter PCA FFCs or wire-harness connectors.

1. **M427/M426 only:** Remove the guide (callout 1).

Figure 1-1784 Remove the guide

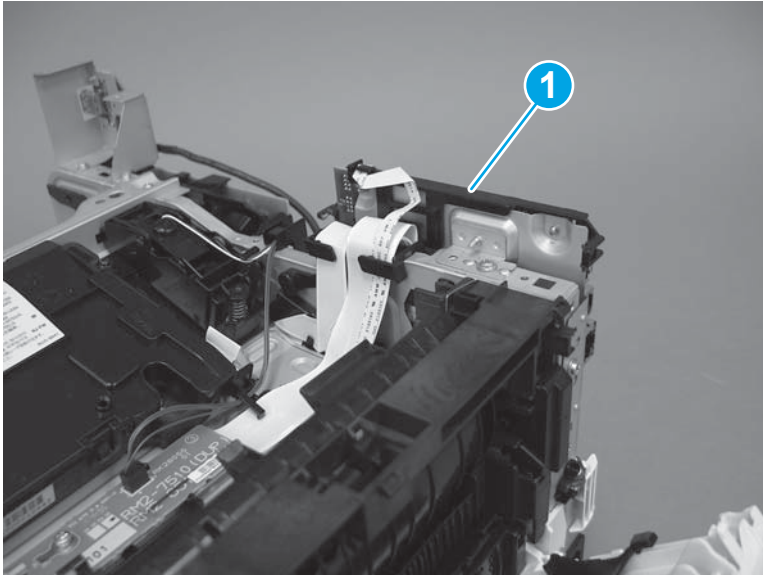

2. Remove two screws (callout 1).

Figure 1-1785 Remove two screws

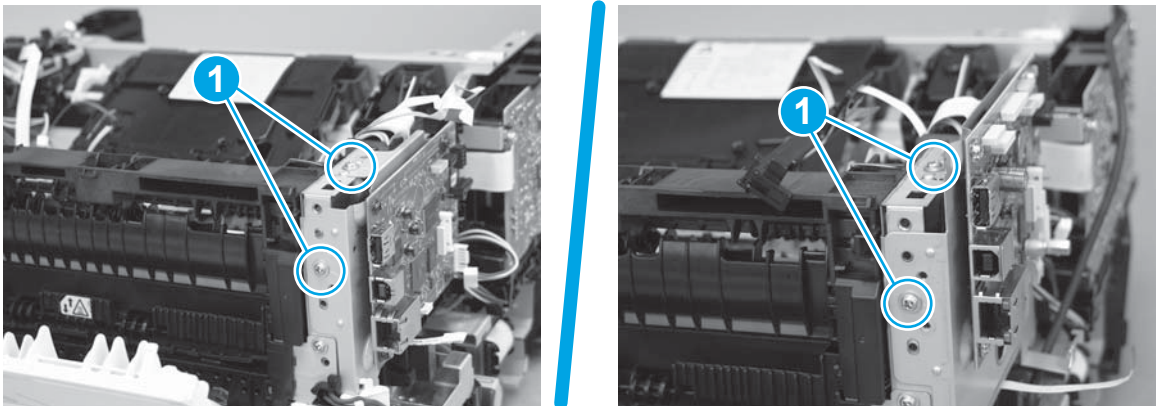

3. Disconnect one connector (callout 1), and then release the wire harness from the guide (callout 2).

Figure 1-1786 Disconnect one connector

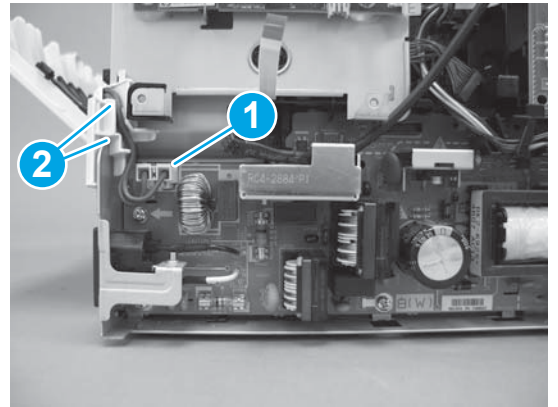
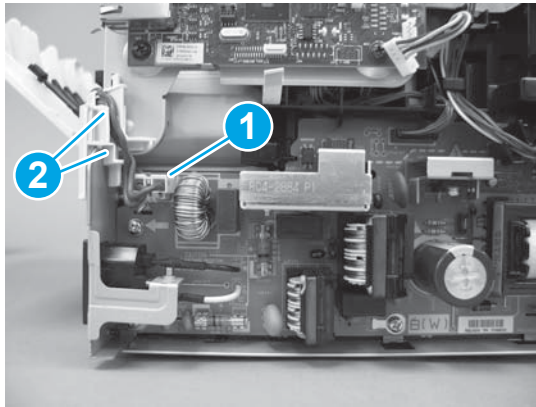

4. Remove the guide (callout 1).

Figure 1-1787 Remove the guide

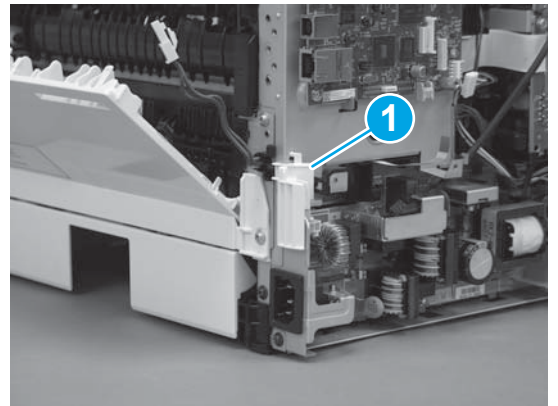
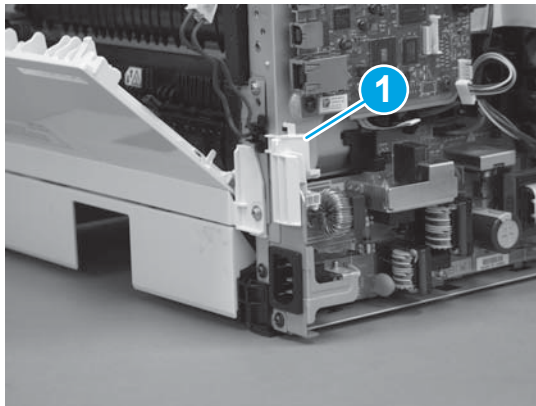

5. Remove three screws (callout 1).

Figure 1-1788 Remove three screws

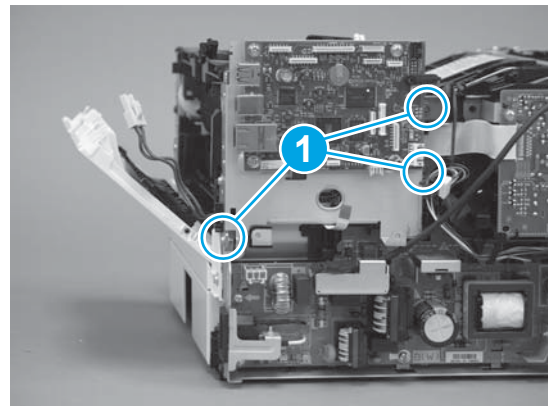
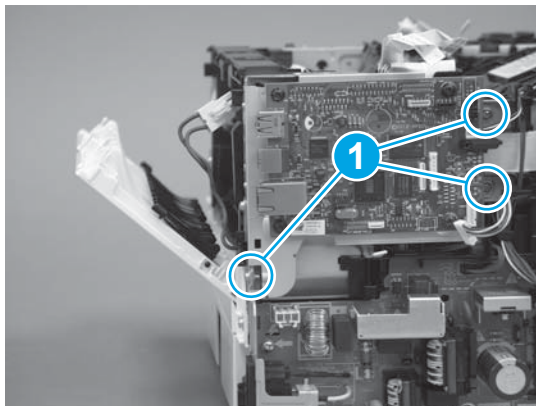

6. Remove the sheet-metal bracket and formatter PCA.

Figure 1-1789 Remove the bracket

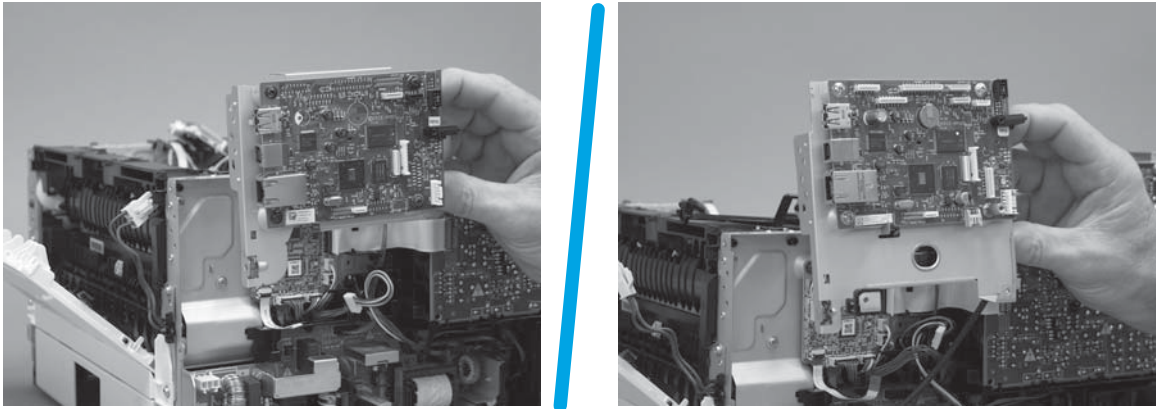

Step 11: Remove the HVPS

1. Disconnect one FFC (callout 1) on the DC controller, and then release it from the guide (callout 2).

Figure 1-1790 Disconnect one FFC

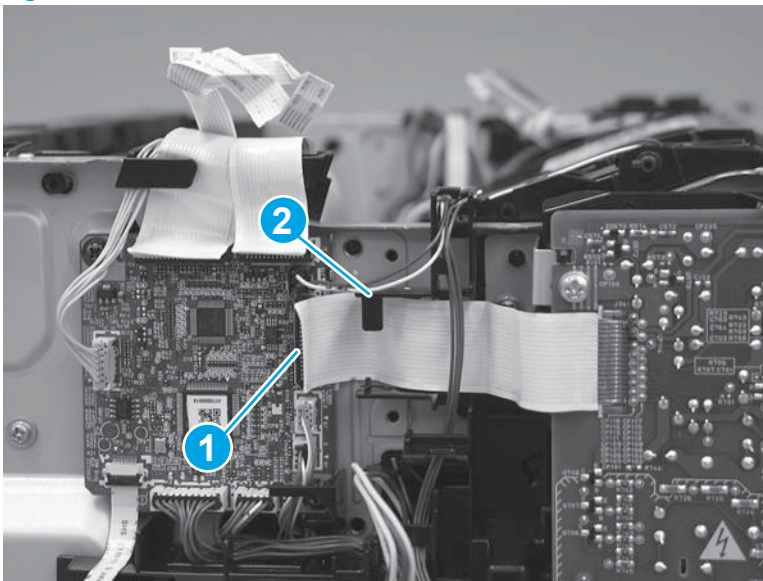

2. Disconnect one connector (callout 1).

Figure 1-1791 Disconnect one connector

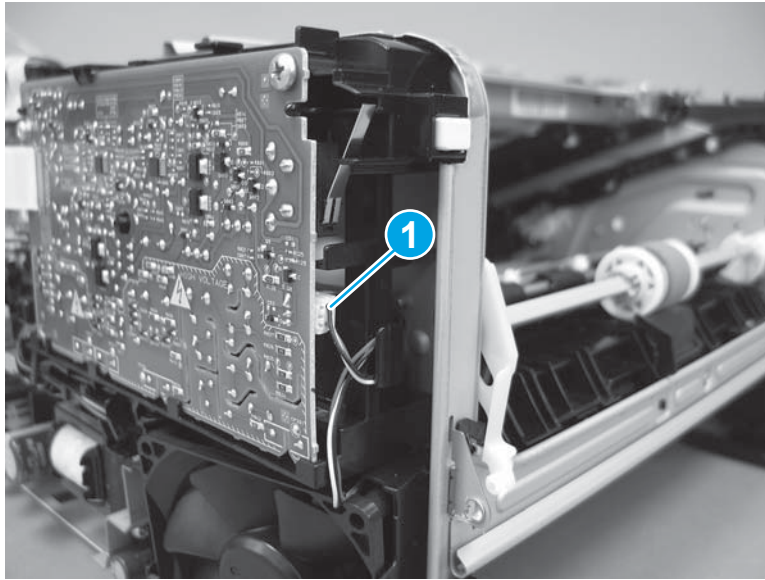

3. Remove two screws (callout 1).

Figure 1-1792 Remove two screws

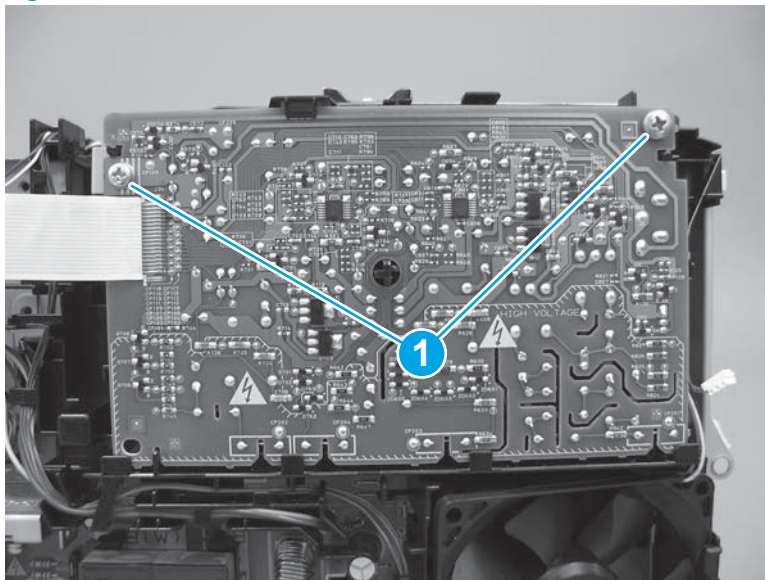

4. Release one tab (callout 1), and then rotate the top of the HVPS away from the printer.

Figure 1-1793 Release one tab

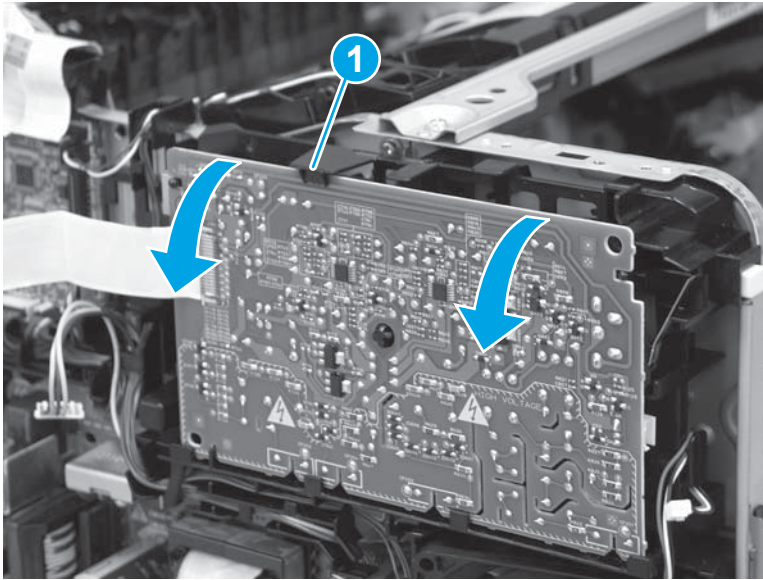

5. Slide the HVPS up and away from the holder to remove it.

Figure 1-1794 Remove the HVPS

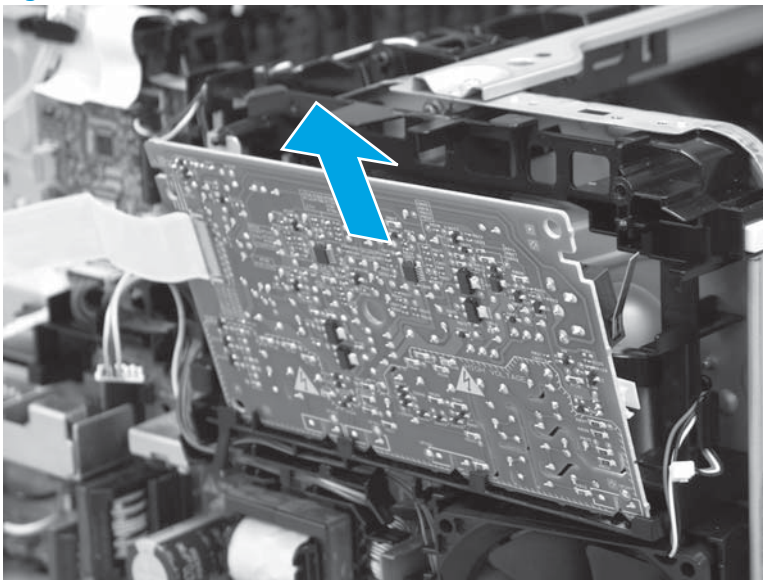

Step 12: Unpack the replacement assembly

Unpack the replacement part from the packaging.

<http://www8.hp.com/us/en/hp-information/environment/product-recycling.html>



NOTE: HP recommends responsible disposal of the defective part.

Figure 1-1795 Recycle and unpack

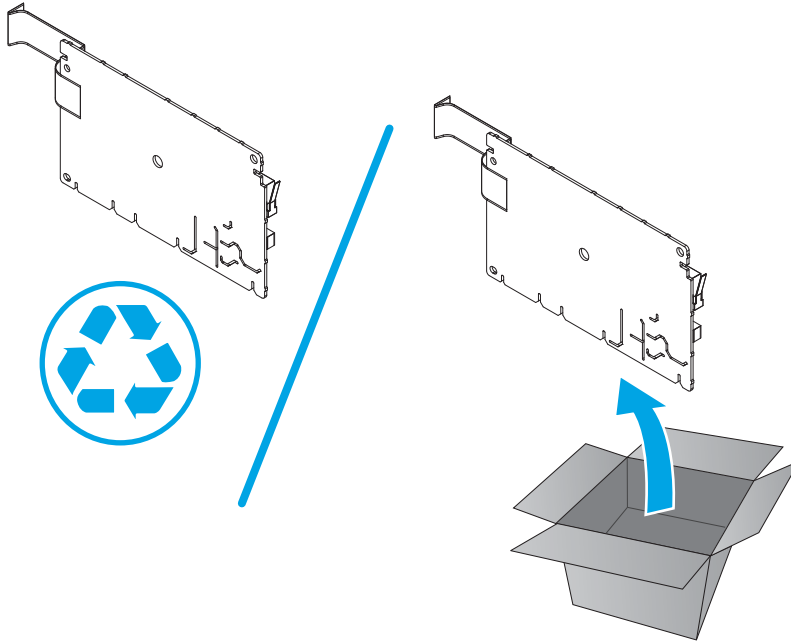

Step 13: Install the HVPS

1. Position the HVPS in the holder with the bottom edge behind the taps on the holder (callout 1).



NOTE: If the HVPS is not correctly installed, the high-voltage springs will not touch the HVPS contacts and the printer will not properly function.

Figure 1-1796 Position the HVPS in the holder

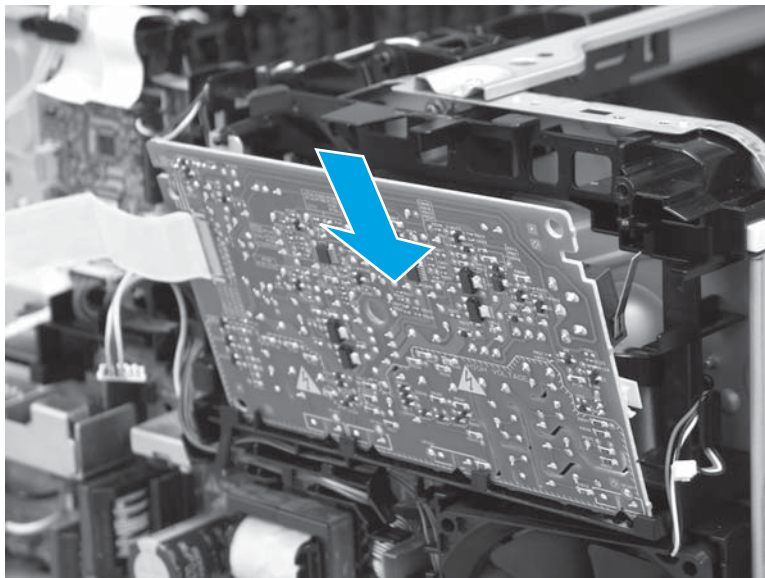

2. Rotate the top of the HVPS toward the printer (callout 1) until the tab (callout 2) snaps into place.

⚠ CAUTION: Do not damage the toner-cartridge detection switch lever (callout 3) when installing the HVPS

Figure 1-1797 Engage one tab

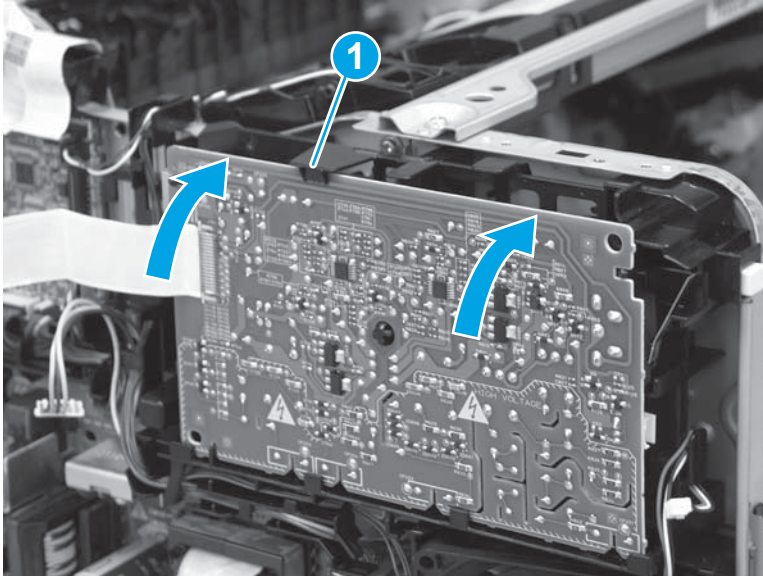

3. Install two screws (callout 1).

Figure 1-1798 Install two screws

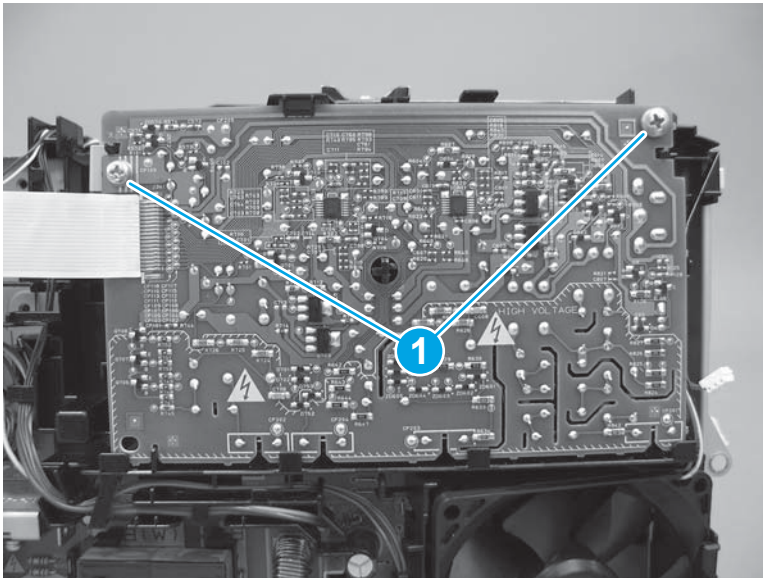

4. Connect one connector (callout 1).

Figure 1-1799 Connect one connector

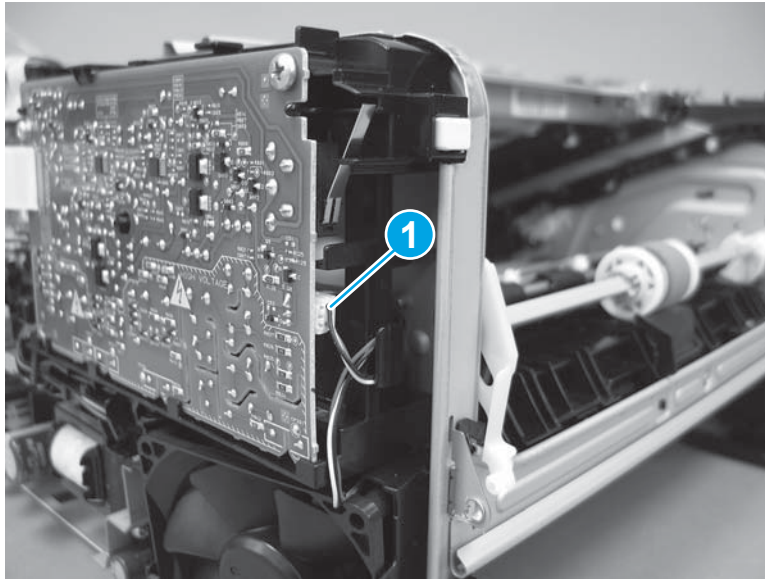

5. Install the FFC in the guide (callout 1), and then connect the FFC to the DC controller (callout 2).

Figure 1-1800 Connect one FFC

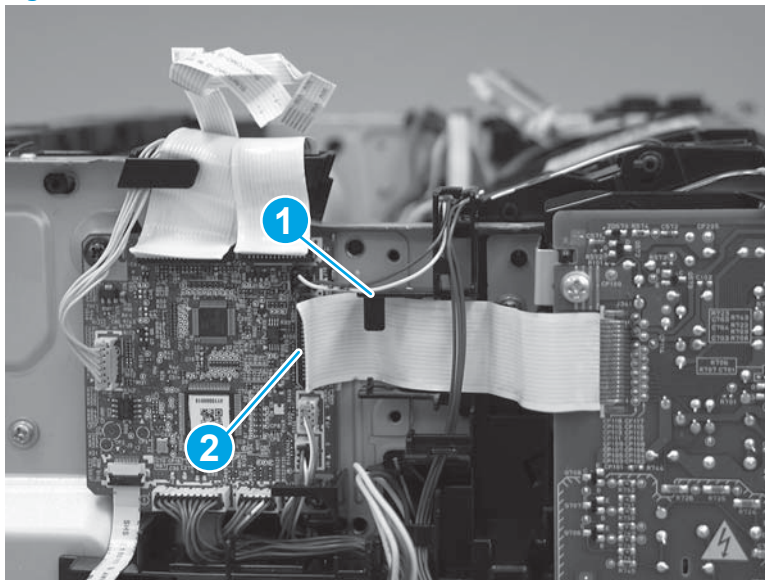

Step 14: Install the sheet-metal formatter bracket and formatter PCA

 **NOTE:** Do not forget to connect any formatter PCA FFCs or wire-harness connectors that were disconnected when the bracket was removed.

1. Position the sheet-metal bracket and formatter PCA on the printer.

Figure 1-1801 Install the bracket

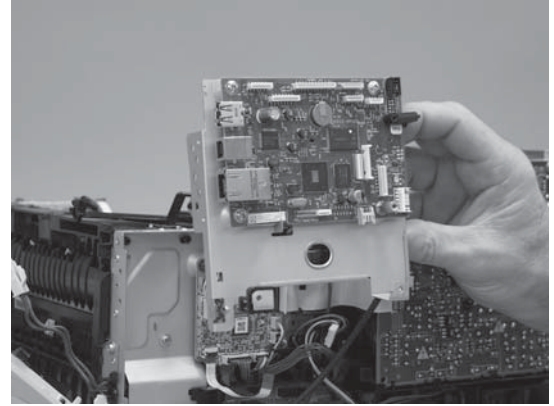
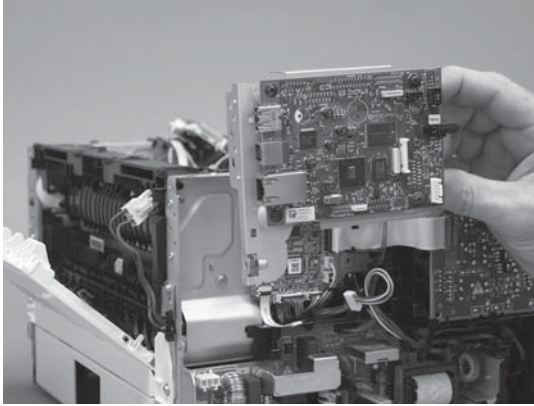

2. Install three screws (callout 1).

Figure 1-1802 Install three screws

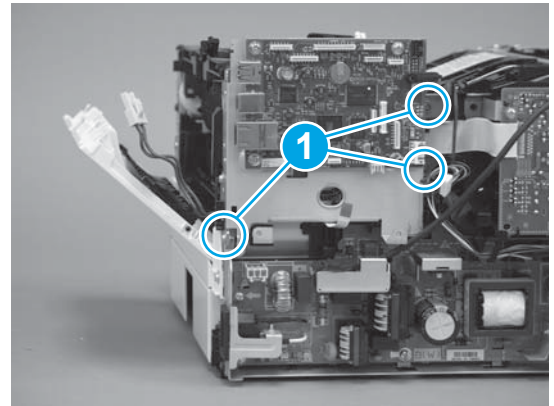
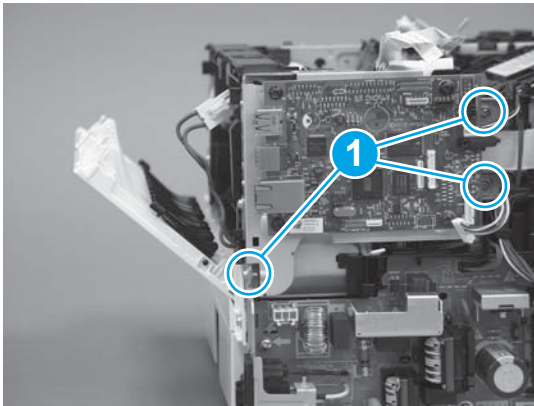

3. Install the guide (callout 1).

Figure 1-1803 Install the guide

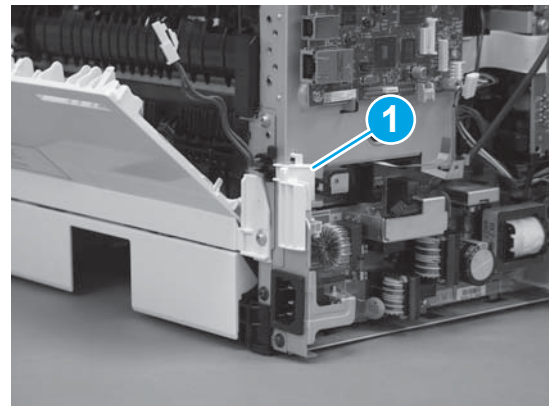
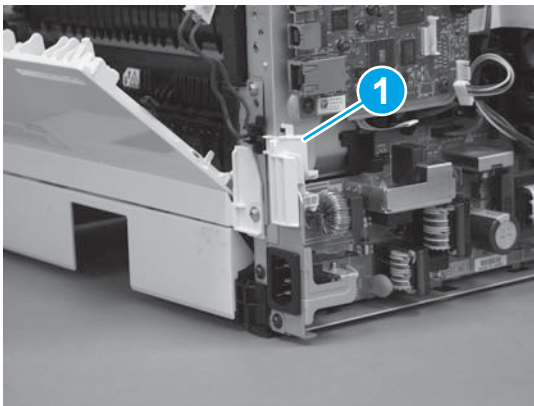

4. Connect one connector (callout 1), and then install the wire harness in the guide (callout 2).

Figure 1-1804 Connect one connector

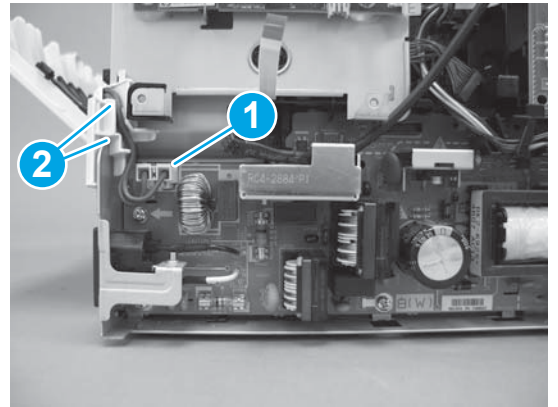
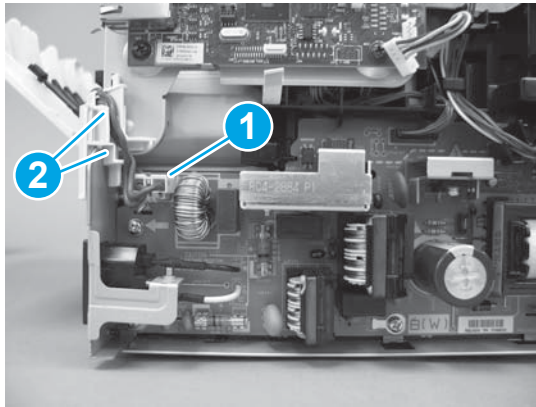

5. Install two screws (callout 1).

Figure 1-1805 Install two screws

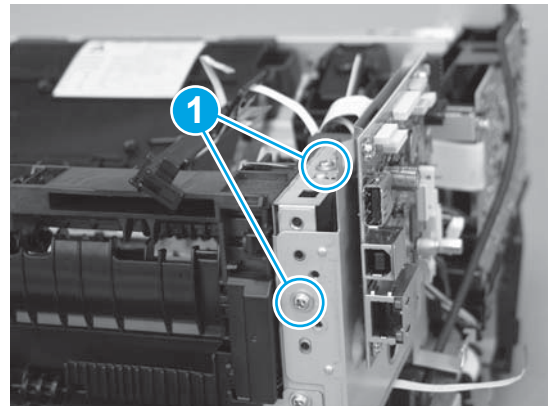
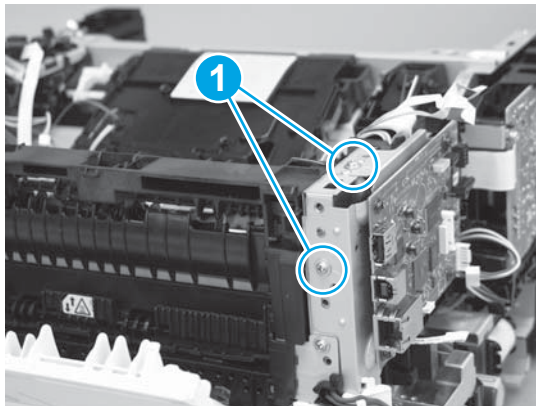

6. **M427/M426 only:** Install the guide (callout 1).

Figure 1-1806 Install the guide

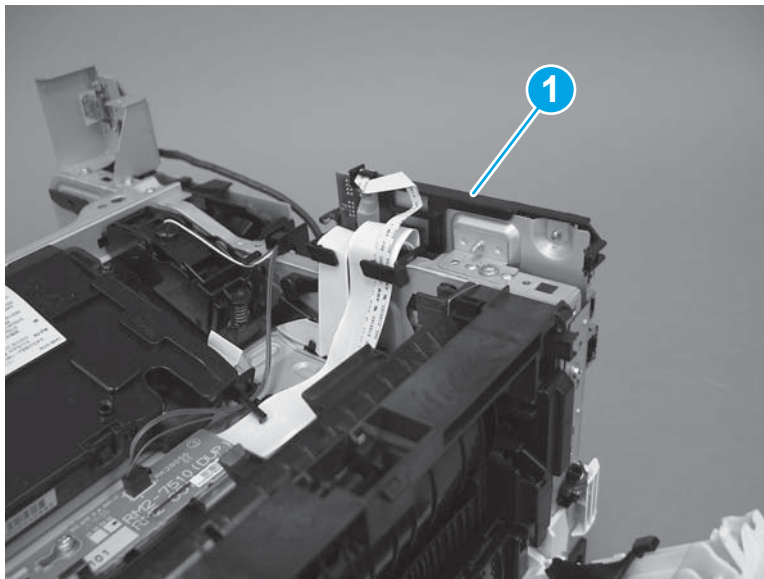

Step 15: Install the paper delivery tray (output bin)

 **NOTE:** This procedure shows the M403/M402 model, however, the paper delivery tray (output bin) removal is similar for the M427/M426 printer.

- ▲ Position the remove the paper delivery tray (output bin; callout 1) on the printer, engage two tabs (callout 2), and then engage two bosses (callout 3).

Figure 1-1807 Engage two tabs

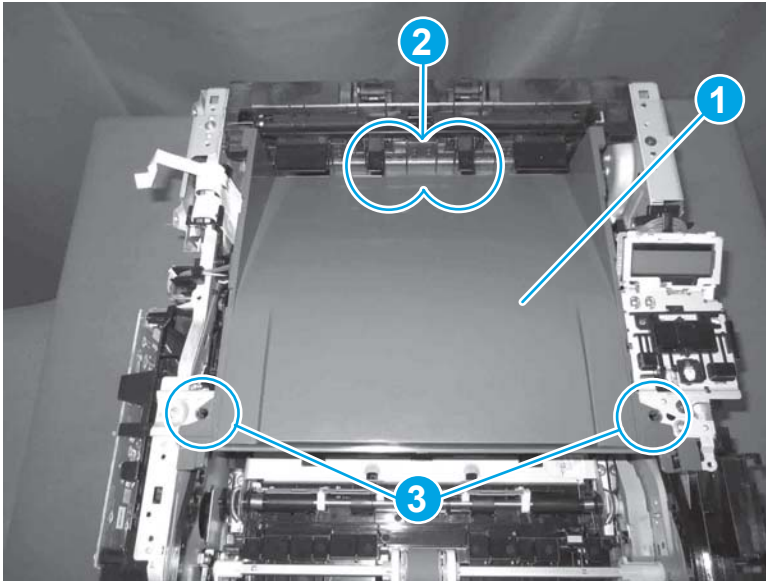

Step 16: Install the top cover (M403/M402)

 **NOTE:** The step is for the M403/M402 printer. For the M427/M426, skip this step and go to [Step 17: Install the top cover \(M427/M426\) on page 958](#).

1. Position the rear edge of the cover on the printer.

Figure 1-1808 Install the cover

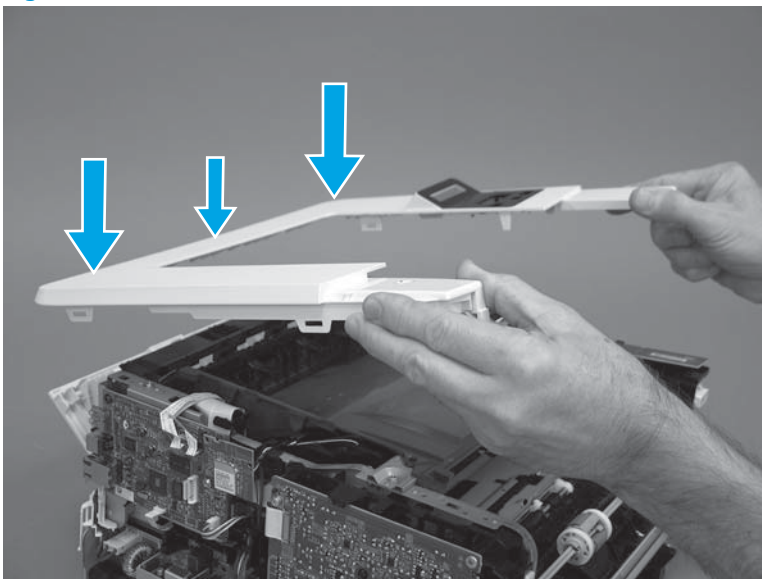

- Engage four bosses (callout 1), rotate the front of the cover down (callout 2) and onto from the printer, and then engage four tabs (callout 3).

Figure 1-1809 Engage four bosses and tabs

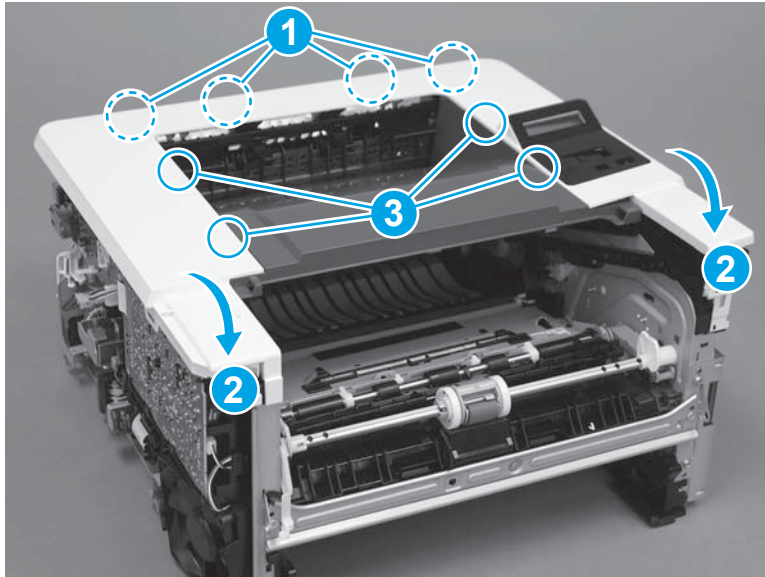

- At the right side of the printer, engage the one boss and one tab (callout 1).

Figure 1-1810 Engage one boss and one tab

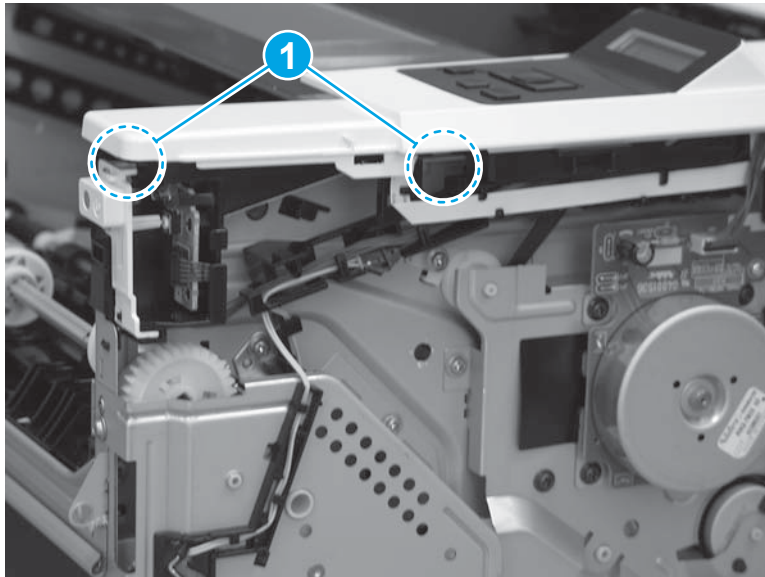

4. Install one screw (callout 1).

Figure 1-1811 Install one screw

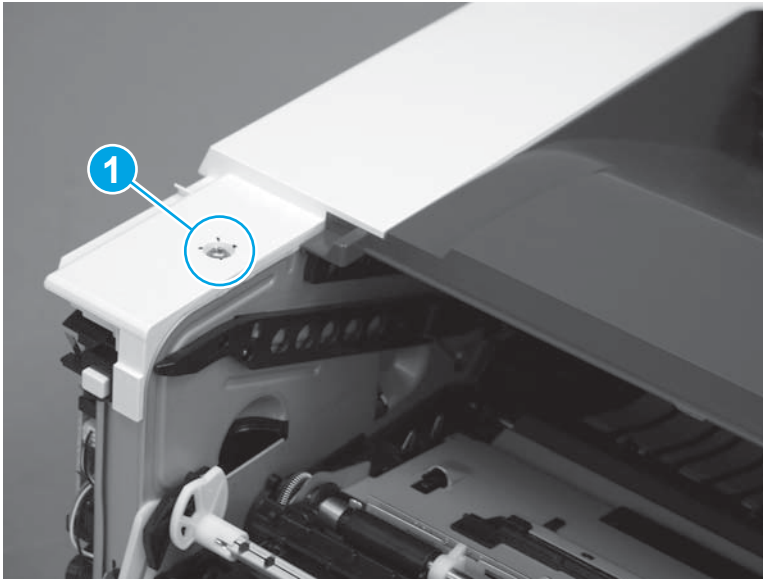

Step 17: Install the top cover (M427/M426)

 **NOTE:** The step is for the M427/M426 printer. For the M403/M402, skip this step and go to [Step 20: Install the right cover on page 969](#).

1. Position the rear edge of the top cover on the printer.

Figure 1-1812 Install the cover

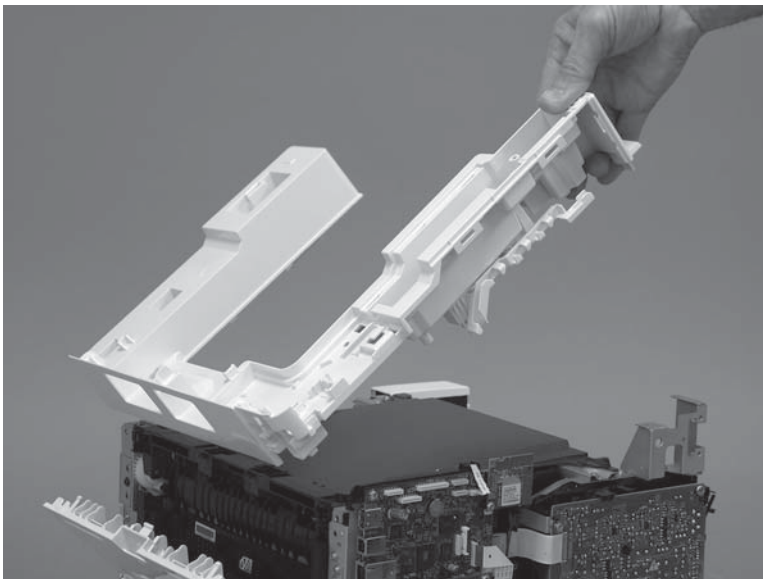

2. Engage four bosses (callout 1).

Figure 1-1813 Engage four bosses

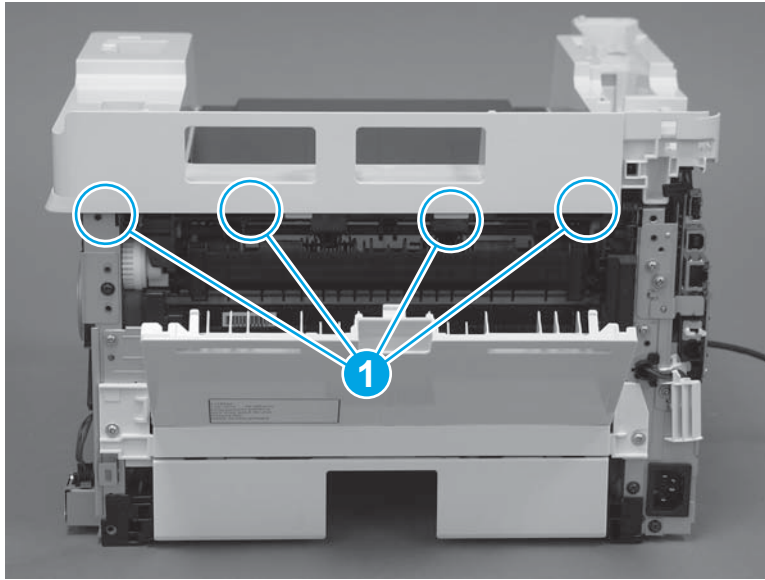

3. Rotate the front edge of the cover down.

Figure 1-1814 Rotate the front edge of the cover down

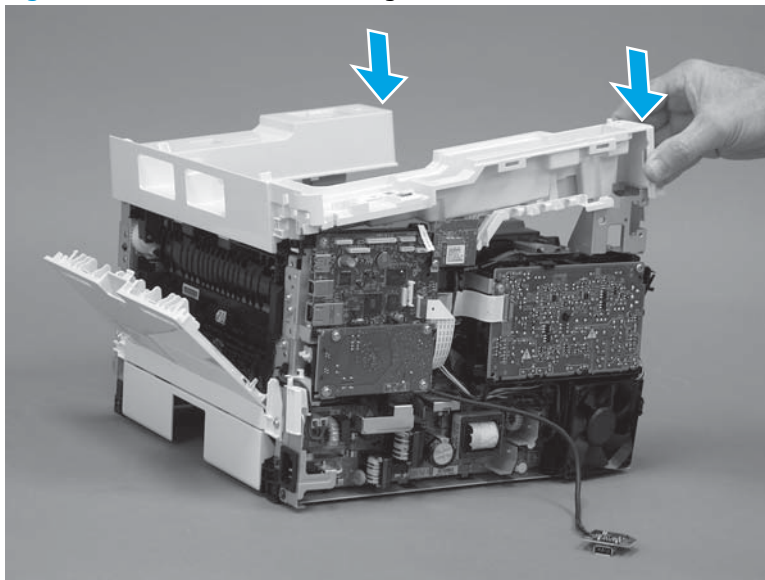

4. Install the USB cable (callout 1) in the guide.

Figure 1-1815 Install the USB PCA

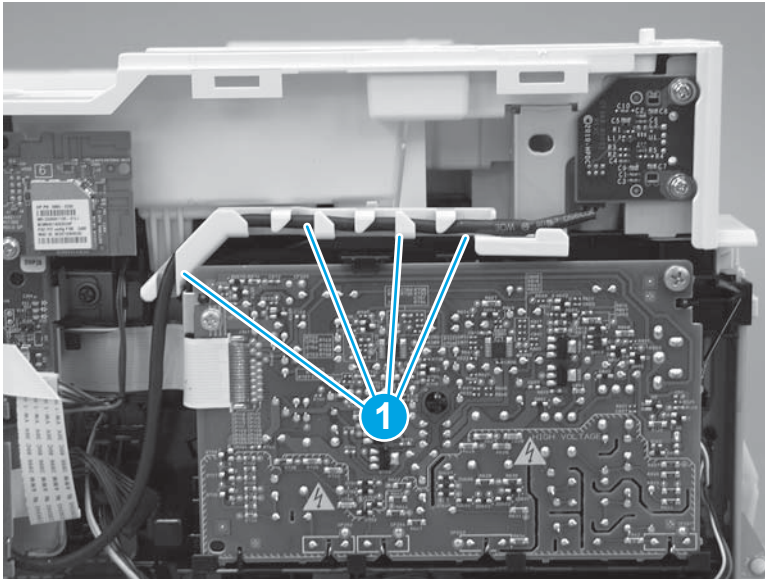

5. Install five screws (callout 1).

Figure 1-1816 Install five screws

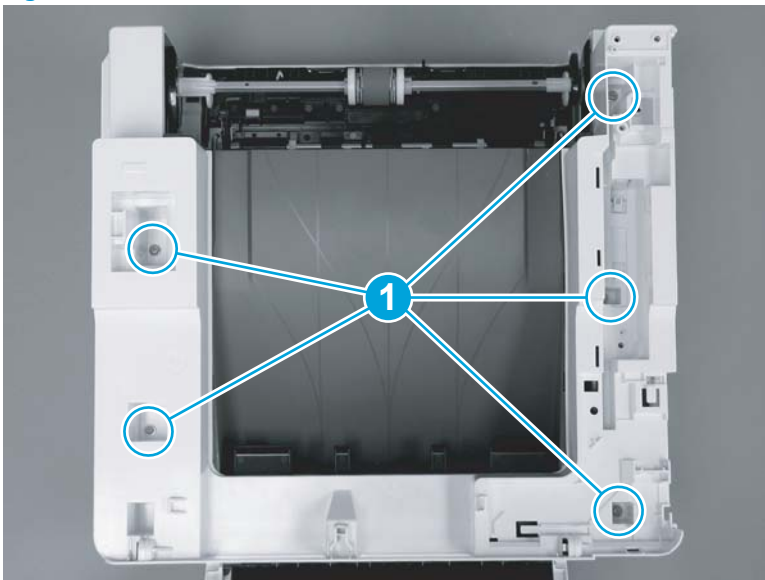

Step 18: Install the control panel (M427/M246)

 **NOTE:** The step is for the M427/M426 printer. For the M403/M402, skip this step and go to [Step 20: Install the right cover on page 969](#).

1. Slide the control-panel FFC cover into the slot in the top cover (next to the document feeder support arm) to install it.

Figure 1-1817 Install the control-panel FFC cover

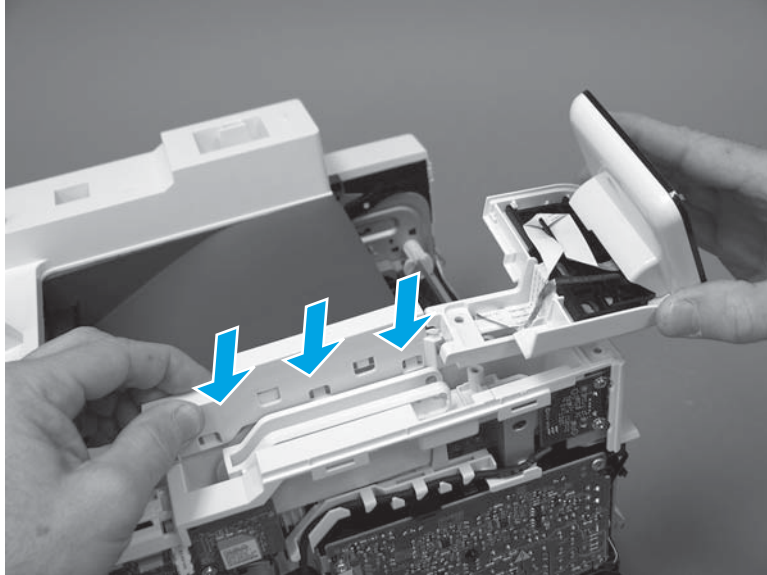

2. Install the control-panel assembly on the top cover.

Figure 1-1818 Install the control-panel assembly

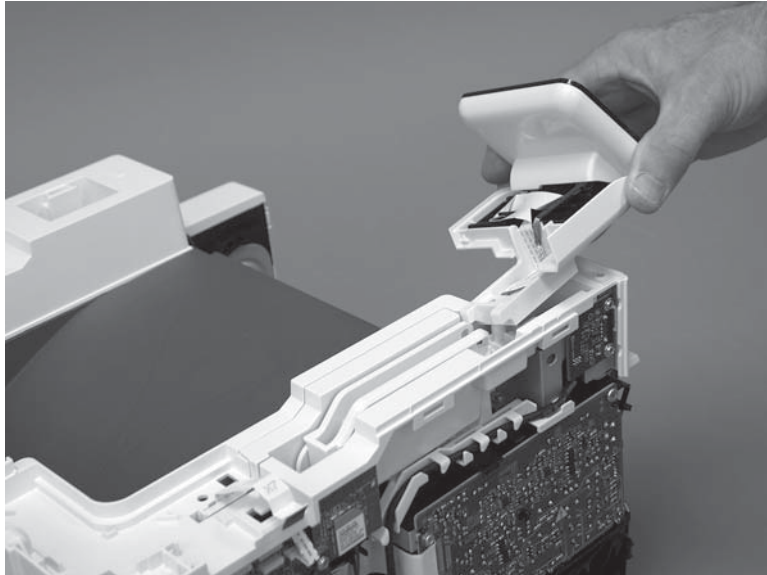

3. Move the FFC out of the way, and then install two screws (callout 1).

Figure 1-1819 Install two screws

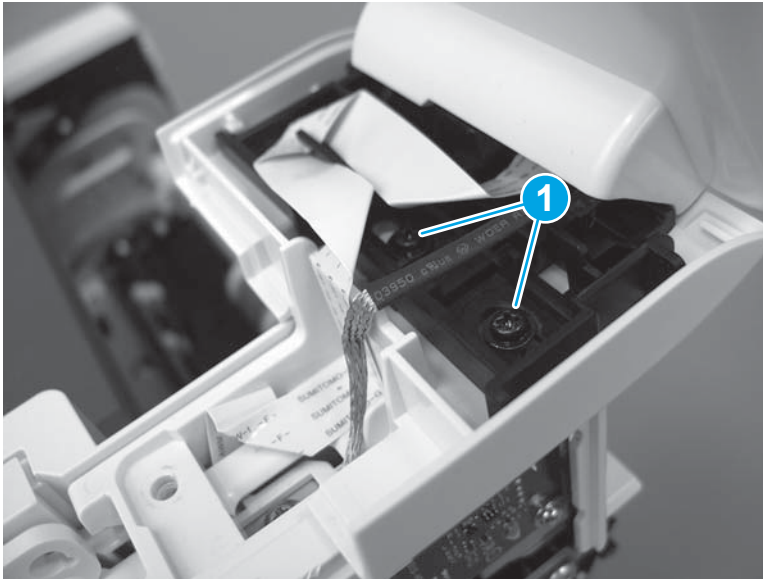

4. Install one grounding screw (callout 1), and then make sure that the ground cable (callout 2) is properly routed.

Figure 1-1820 Remove one screw

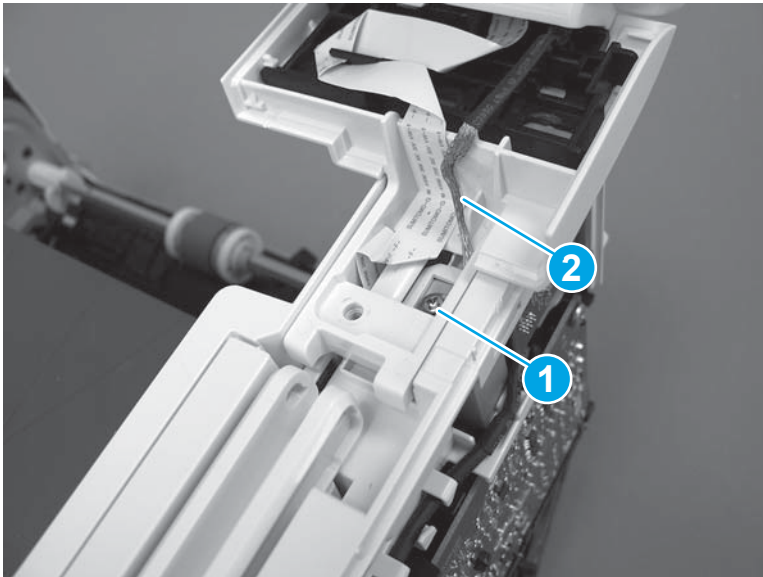

5. Install the control-panel cable cover.

Figure 1-1821 Install the cover

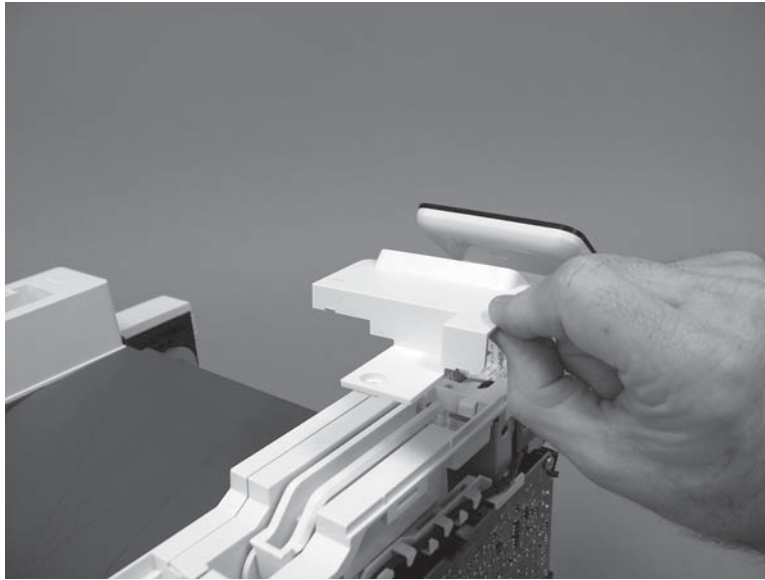

6. Make sure that the two tabs (callout 1) on the cover snap into place.

Figure 1-1822 Engage two tabs

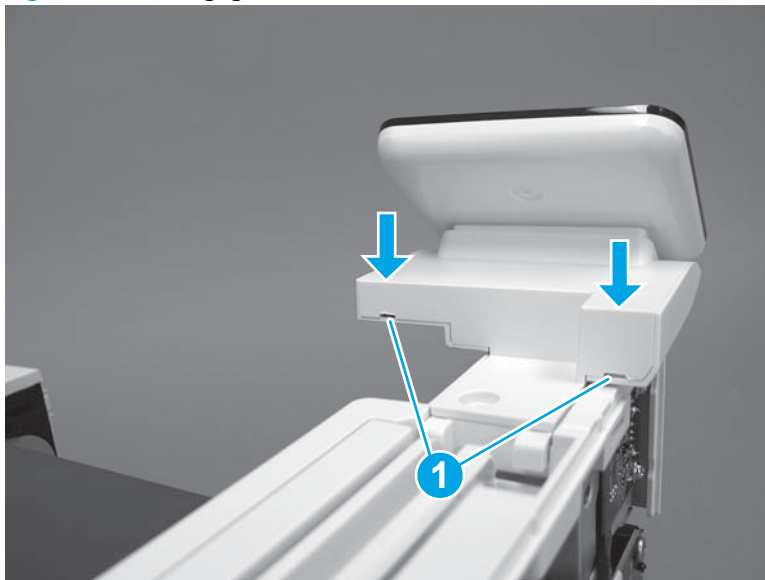

7. Install one screw (callout 1).

Figure 1-1823 Install one screw

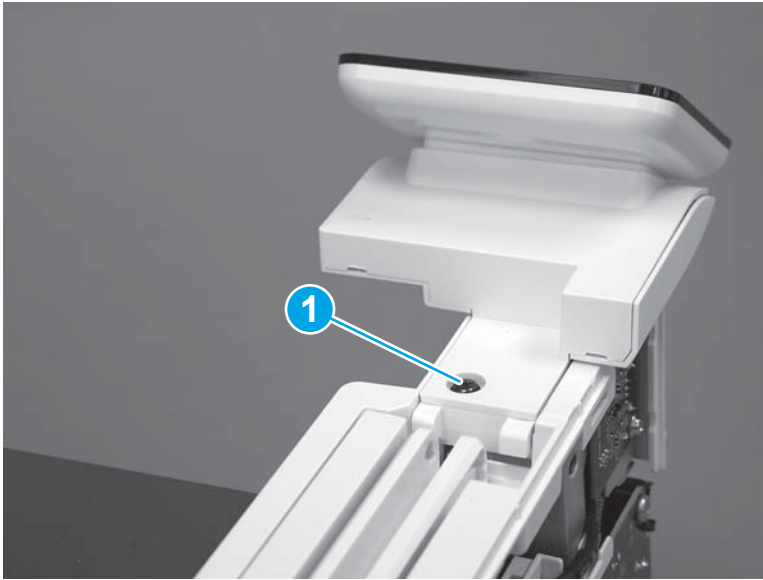

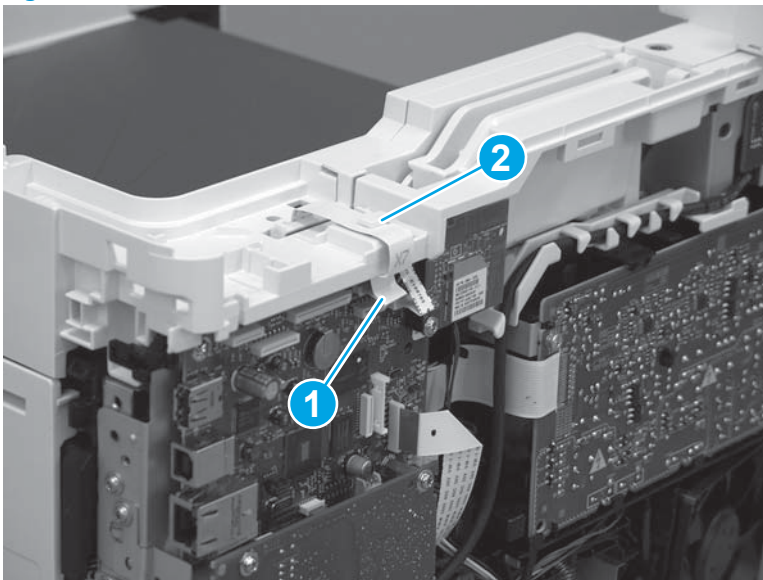

8. Install the FFC in the retainer (callout 1), and then connect one FFC (callout 1; J114).

Figure 1-1824 Connect one connector



Step 19: Install the integrated scanner assembly (M427/M246)

 **NOTE:** The step is for the M427/M426 printer. For the M403/M402, skip this step and go to [Step 20: Install the right cover on page 969](#).

 **NOTE:** M427/M426 models only. The integrated scanner assembly (ISA) includes the sub-scanner assembly (SSA) and the automatic document feeder (ADF).

1. Position the ISA on the printer.

Figure 1-1825 Position the ISA on the printer

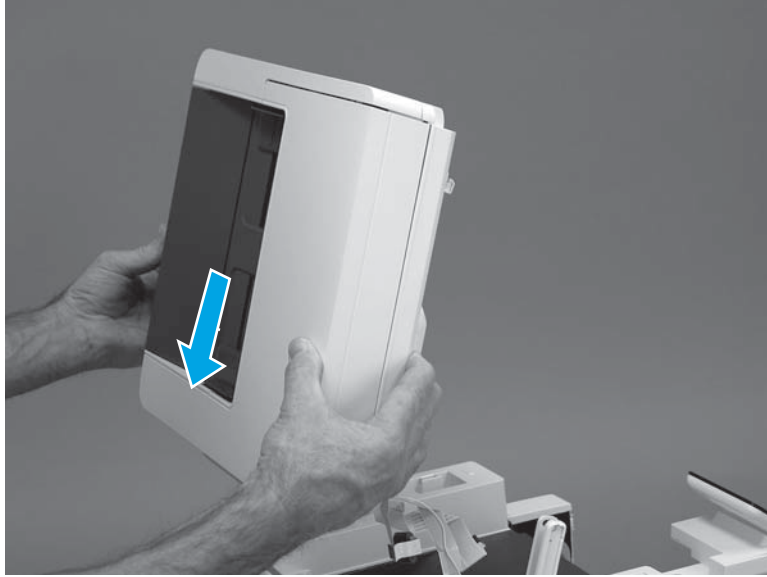

2. Engage the hinge pins on the ISA with the holders in the top cover (callouts 1/2), and then slide the ISA as shown to engage them

Figure 1-1826 Engage the hinge pins with the holders

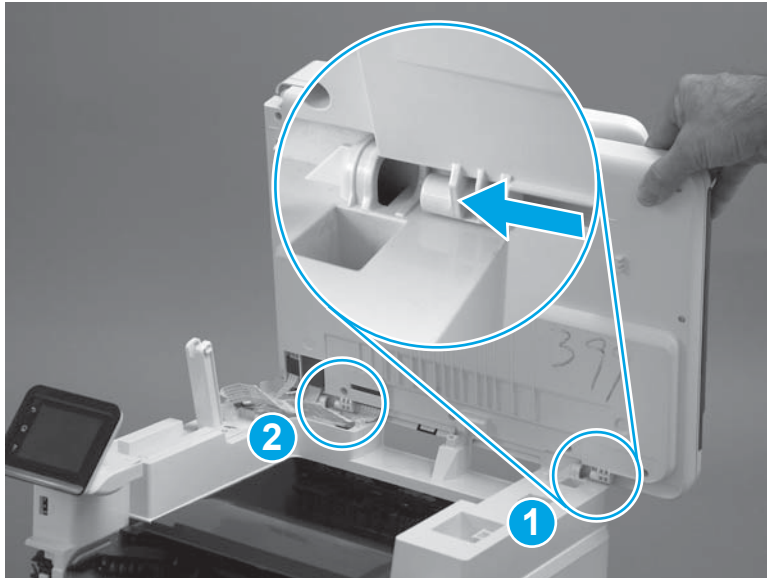

3. Rotate the ISA towards the front of the printer until it rests on the ISA lift assembly (callout 1).

Figure 1-1827 Rotate the ISA towards the front of the printer

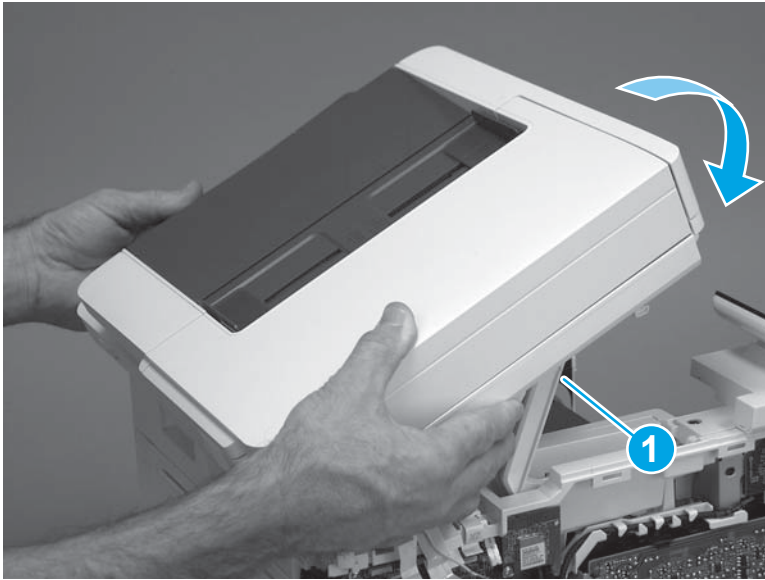

4. Pass the ground wire through the opening in the top cover.

Figure 1-1828 Pass the wire through the opening

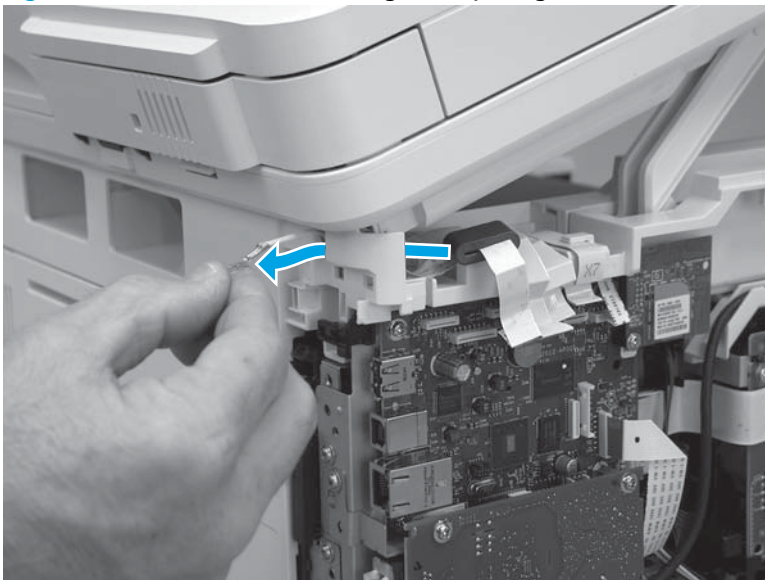

5. Install one screw (callout 1).

Figure 1-1829 Install one screw

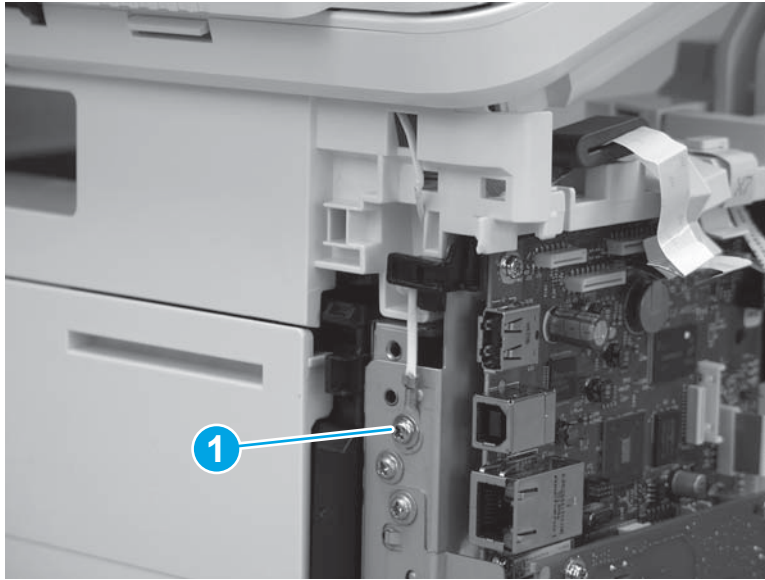

6. Install the ISA lift assembly slider pin.

 **Reinstallation tip:** Align the keyed portion of the locking pin with the slot and hole in the support arm.

Figure 1-1830 Install the slider pin



7. Rotate the slider pin (callout 1) towards the rear of the printer until the tab (callout 2) snap into place.

Figure 1-1831 Secure the slider pin

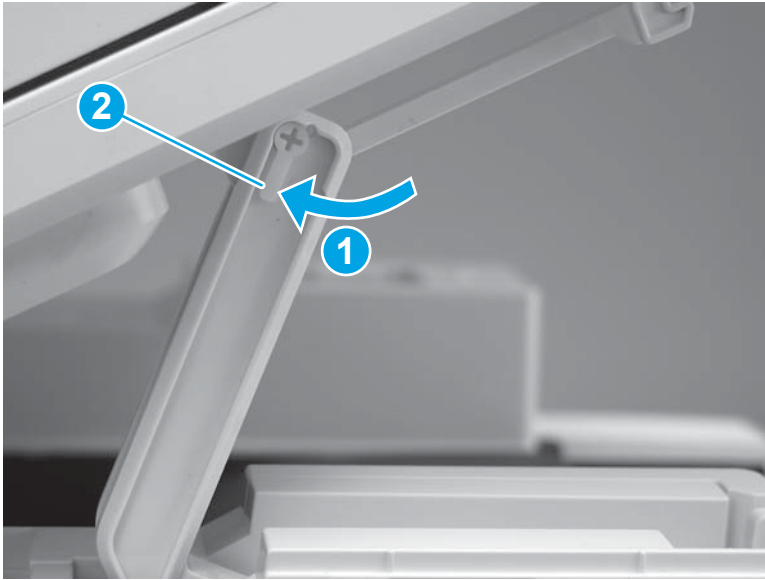

8. Install the ferrite (callout 1) in the holder, and then connect three FFCs (callout 2).

Figure 1-1832 Connect three FFCs

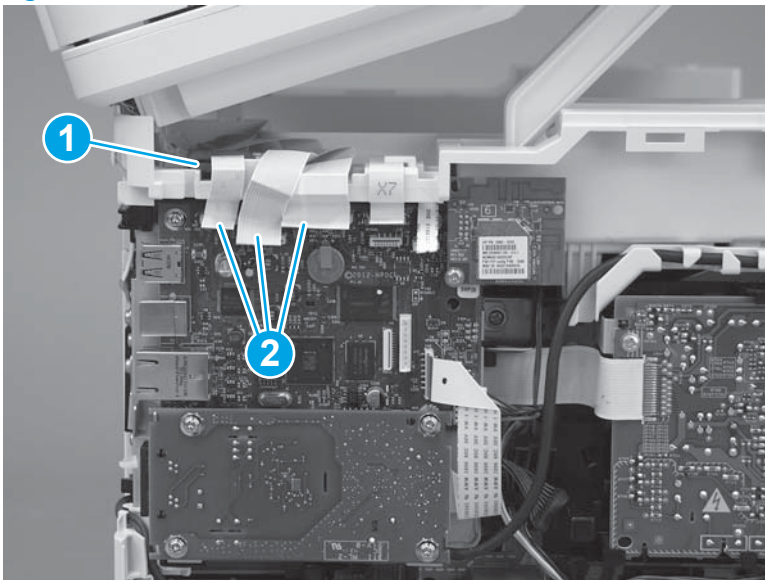

9. Position the rear edge of the ISA flat-flexible cable (FFC) cover on the printer (callout 1) , and then rotate it down (callout 2) until it snaps into place.

Figure 1-1833 Install the ISA FFC cover

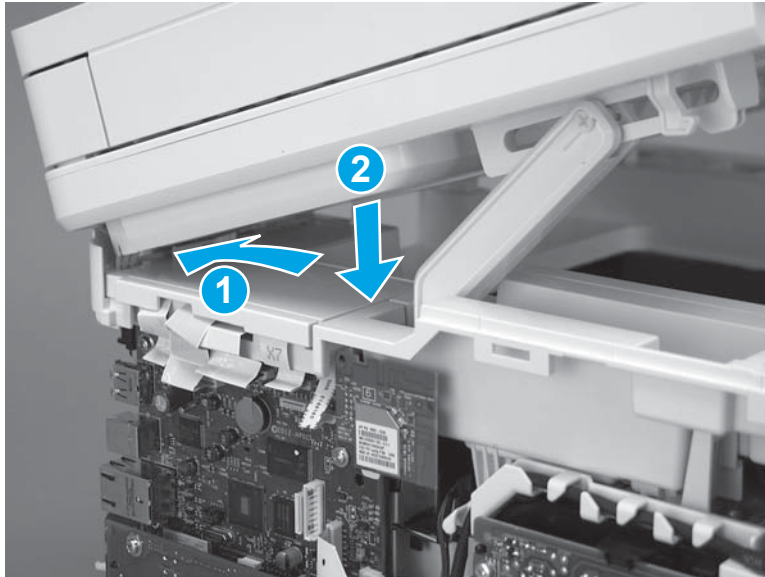

10. Lower the ISA.

Figure 1-1834 Lower the ISA

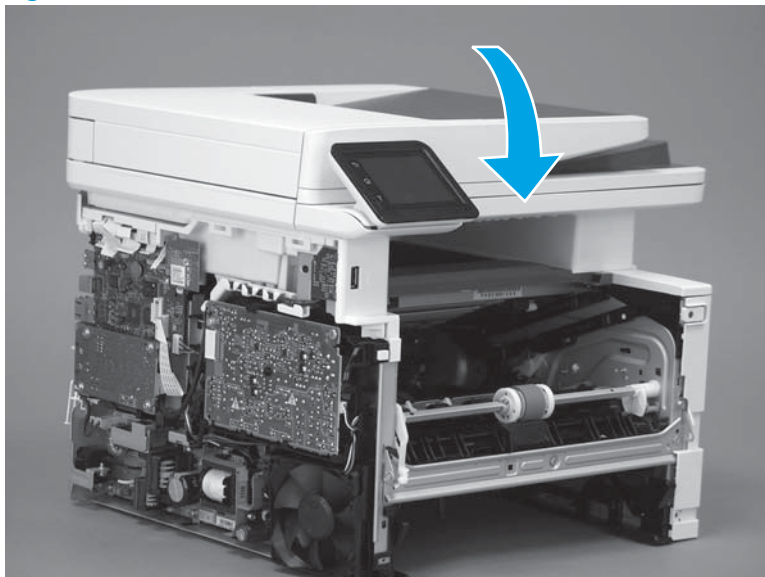

Step 20: Install the right cover

1. Position the cover (callout 1) on the printer, and then engage two bosses (callout 2).

Figure 1-1835 Install the cover

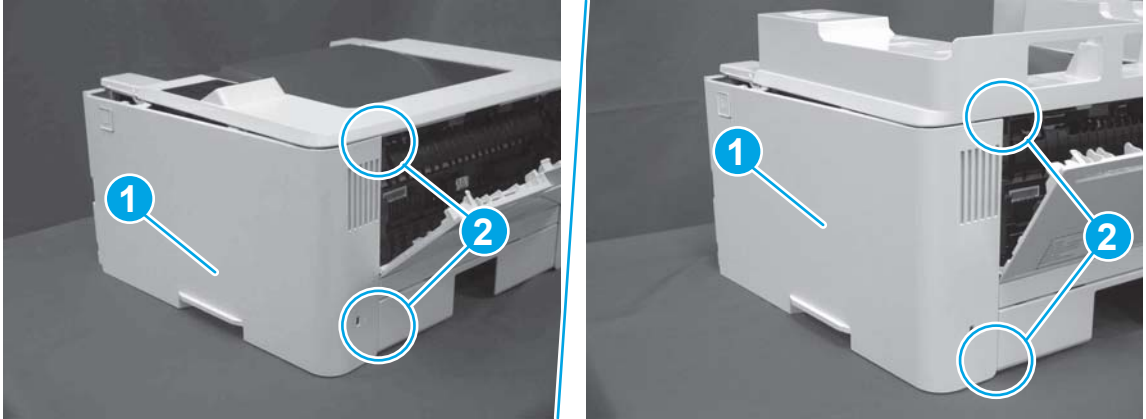

2. Rotate the front of the cover onto the printer (callout 1), engage three (callout 2) tabs, and then engage two bosses (callout 3).

Figure 1-1836 Engage two bosses and one tab

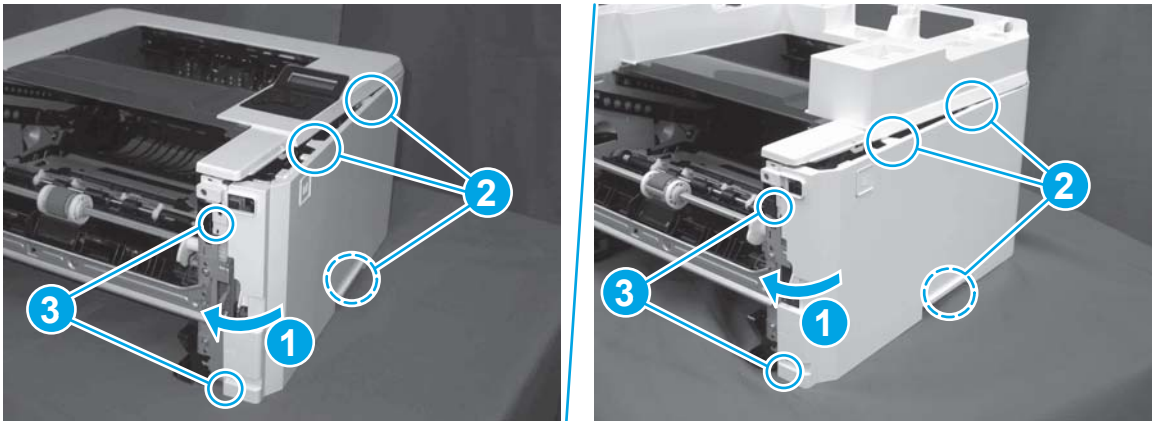

3. Make sure that the power switch (callout 1) and cartridge door assembly button (callout 2) correctly function.

 **NOTE:** Remove, and then reinstall the cover if the switch or button does not correctly function.

Figure 1-1837 Check the power switch and cartridge door assembly button



4. Install one screw (callout 1).

Figure 1-1838 Install one screw

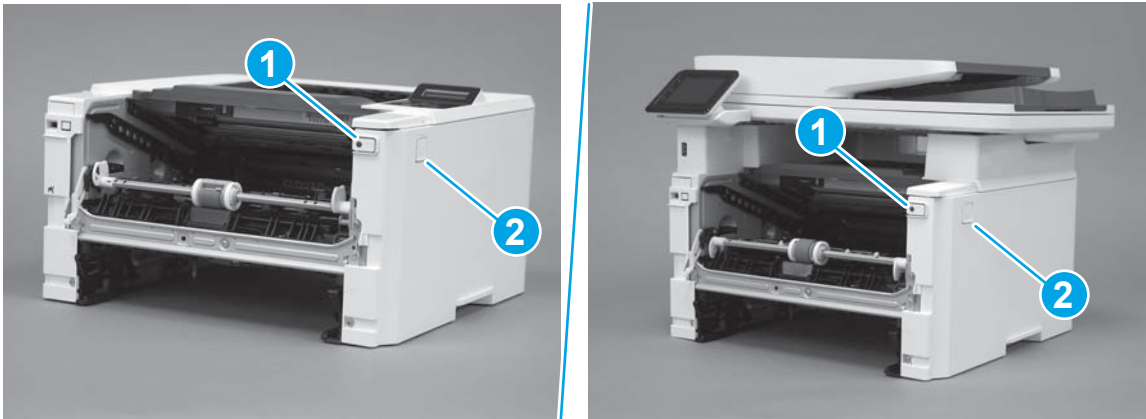

Step 21: Install the left cover

1. At the front of the printer, do one of the following:
 - **M403/M402:** Position the cover on the printer (callout 1), and then engage two bosses (callout 2).
 - **M427/M426:** Position the cover on the printer (callout 3), engage one tab (callout 4), and then engage two bosses (callout 4).

Figure 1-1839 Install the cover

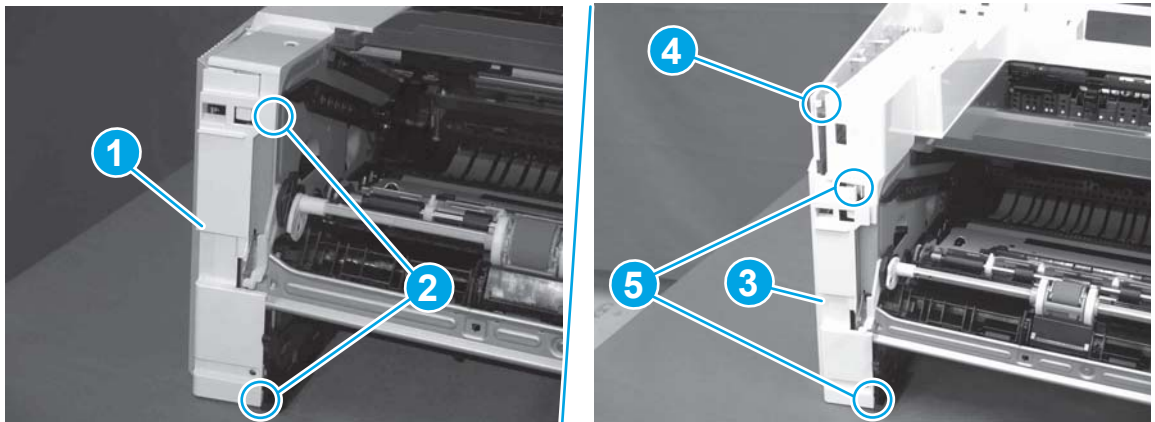

- Carefully rotate the rear of the cover onto the printer (callout 1), engage three tabs (callout 2), and then engage two bosses (callout 3).

Figure 1-1840 Engage three tabs and two bosses

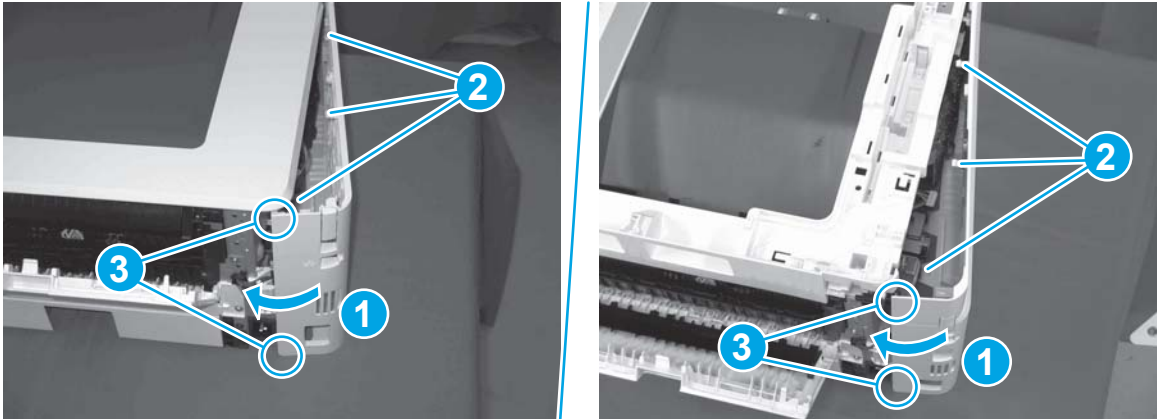

- Install one screw (callout 1).

Figure 1-1841 Install one screw

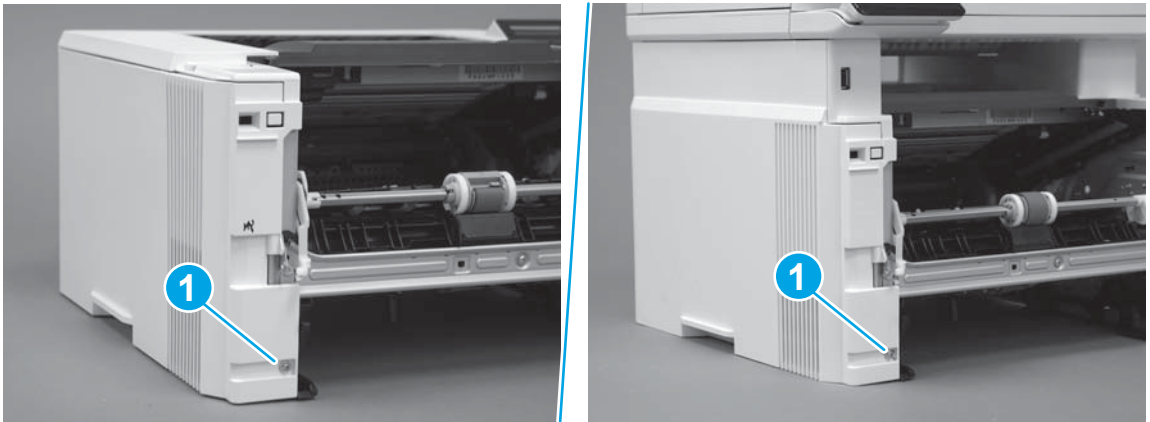

Step 22: Install the cartridge door assembly

 **Reinstallation tip:** After a replacement door is installed, make sure to install the nameplate (supplied in the kit) corresponding to the printer name on the door.

- Position the door close to the printer, and then engage the keyed pin on the left-side retainer arm with the hole in the door.

Figure 1-1842 Engage the left-side retainer arm

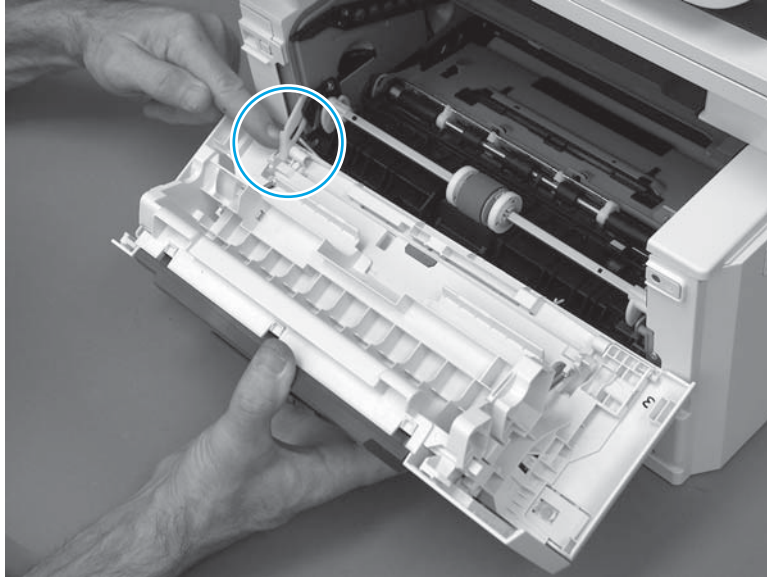

2. Engage the right-side door hinge pin with the hole in the chassis (callout 1).

Figure 1-1843 Install the door

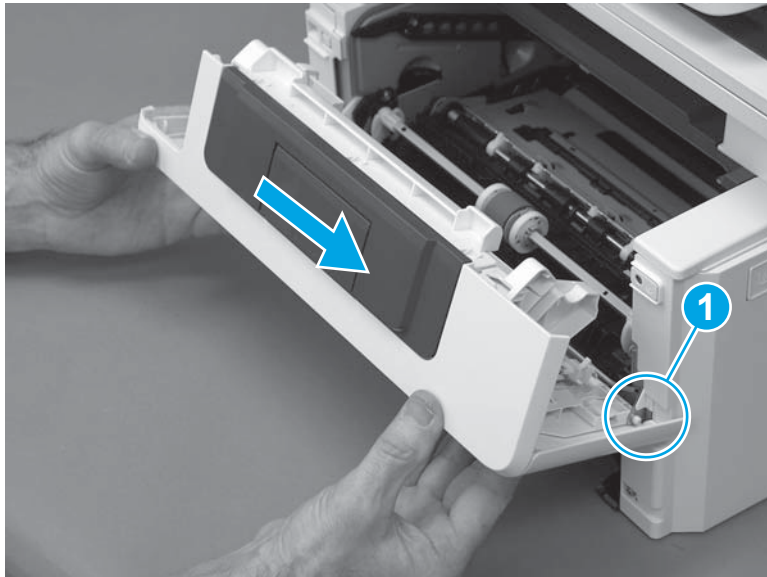

3. Install the link (callout 1).

 **IMPORTANT:** Make sure that the link snaps into place on the arm (callout 2). The link actuates the fuser pressure-release mechanism.

Figure 1-1844 Install the pressure-release link

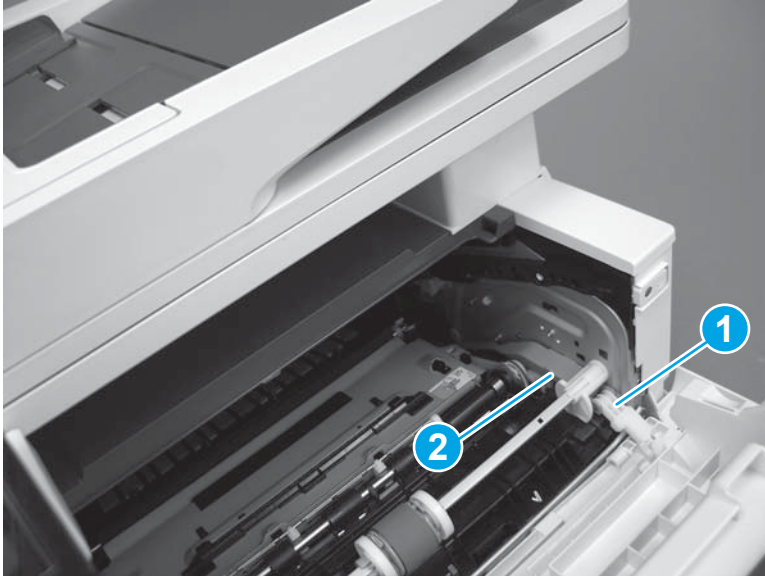

4. Slide the guide into the printer (callout 1), and then make sure that the tab (callout 2) snaps into place to secure the guide to the chassis.

Figure 1-1845 Install the guide

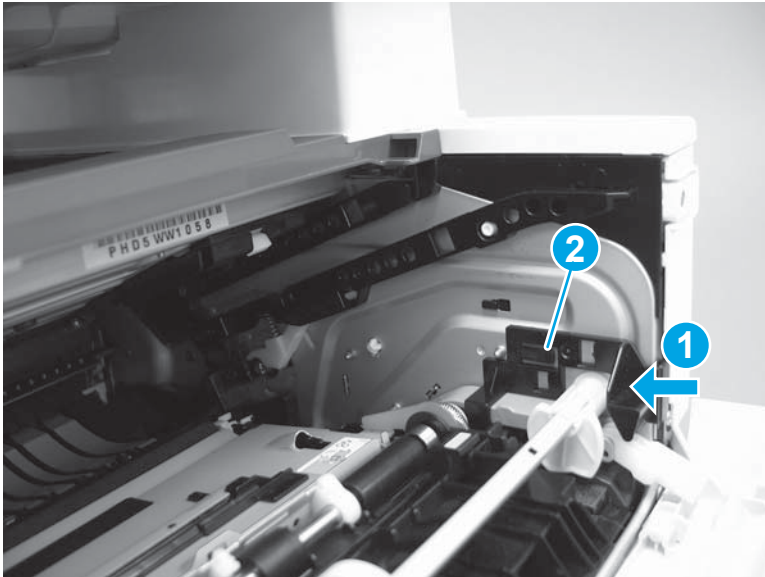

5. Position the shaft on the door, and then align the left-side hinge on the door with the hole in the chassis (callout 1).

Figure 1-1846 Align the hinge

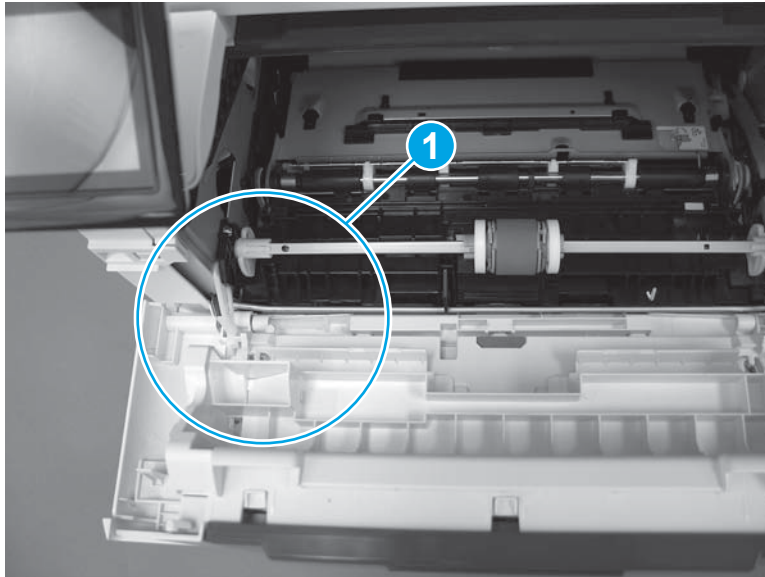

6. Push the shaft towards the left side of the printer to install it (callout 1).

 **Reinstallation tip:** Make sure that the support shaft is fully installed and correctly orientated (callout 2) so that it will not interfere with the door opening and closing.

Figure 1-1847 Install the support shaft



Step 23: Install Tray 2

- ▲ Slide the tray straight into the printer to install it.

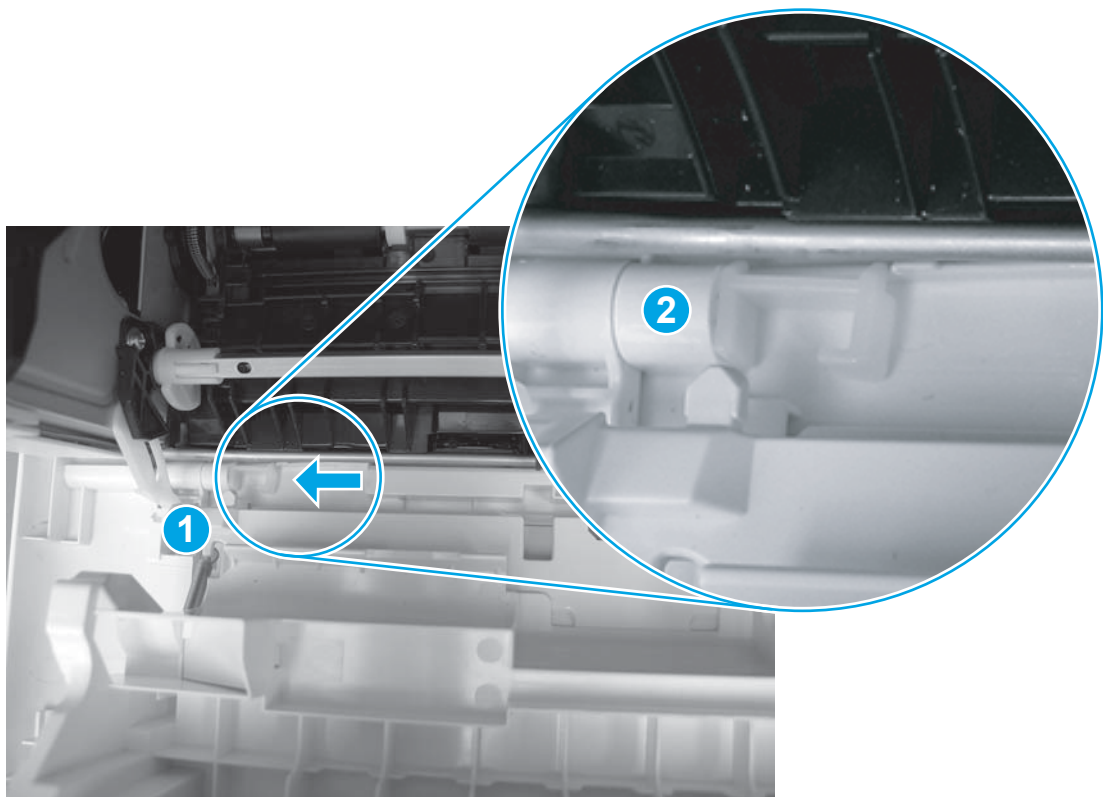
Figure 1-1848 Install the tray



Removal and replacement: Low-voltage power supply

- [Introduction](#)
- [Step 1: Remove Tray 2](#)
- [Step 2: Remove the cartridge door assembly](#)
- [Step 3: Remove the left cover](#)
- [Step 4: Remove the right cover](#)
- [Step 5: Remove the integrated scanner assembly \(M427/M246\)](#)
- [Step 6: Remove the control panel \(M427/M246\)](#)
- [Step 7: Remove the top cover \(M427/M426\)](#)
- [Step 8: Remove the top cover \(M403/M402\)](#)
- [Step 9: Remove the paper delivery tray \(output bin\)](#)
- [Step 10: Remove the fan \(FM1\)](#)
- [Step 11: Remove the sheet-metal formatter bracket and formatter PCA](#)
- [Step 12: Remove the LVPS](#)
- [Step 13: Unpack the replacement assembly](#)
- [Step 14: Install the LVPS](#)
- [Step 15: Install the sheet-metal formatter bracket and formatter PCA](#)
- [Step 16: Install the fan \(FM1\)](#)
- [Step 17: Install the paper delivery tray \(output bin\)](#)
- [Step 18: Install the top cover \(M403/M402\)](#)
- [Step 19: Install the top cover \(M427/M426\)](#)
- [Step 20: Install the control panel \(M427/M246\)](#)
- [Step 21: Install the integrated scanner assembly \(M427/M246\)](#)
- [Step 23: Install the right cover](#)
- [Step 24: Install the left cover](#)
- [Step 25: Install the cartridge door assembly](#)
- [Step 26: Install Tray 2](#)

Introduction

This document provides the procedures to remove and replace the low-voltage power supply (LVPS).

Before performing service

Turn the printer power off

- Disconnect the power cable.

 **WARNING!** To avoid damage to the printer, turn the printer off, wait 30 seconds, and then remove the power cable before attempting to service the printer.

Use the table below to identify the correct part number for your printer. To order the part, go to www.hp.com/buy/parts.

Low-voltage power supply (LVPS) part number	
RM2-8518-000CN	Low-voltage power supply (M427/M426; 110V-127V)
RM2-8519-000CN	Low-voltage power supply (M427/M426; 220V-240V)
RM2-8516-000CN	Low-voltage power supply (M403/M402; 110V-127V)
RM2-8517-000CN	Low-voltage power supply (M403/M402; 220V-240V)

Required tools

- #2 Phillips screwdriver with a magnetic tip.

After performing service

Turn the printer power on

- Connect the power cable.
- Use the power switch to turn the power on.

Post service test

Make sure that the printer initializes to a **Ready** state.

Print a configuration page to make sure that the printer is functioning correctly.

Step 1: Remove Tray 2

- ▲ Pull the tray straight out of the printer to remove it.

Figure 1-1849 Remove the tray



Step 2: Remove the cartridge door assembly

 **NOTE:** If the toner cartridge was not removed prior to servicing the printer, remove it now.

1. Release one tab (callout 1), and then slide shaft (callout 2) in the direction the arrow indicates and remove it.

 **TIP:** It might be easier to release the support shaft by using a small flat-blade screwdriver.

Figure 1-1850 Release the support shaft

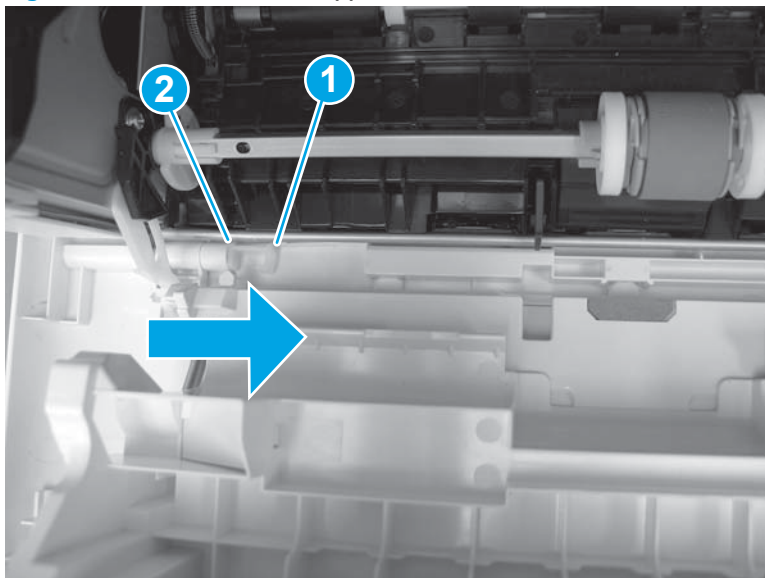

2. Release one tab (callout 1), and then slide the guide (callout 2) in the direction the arrow indicates and remove it.

Figure 1-1851 Remove the guide

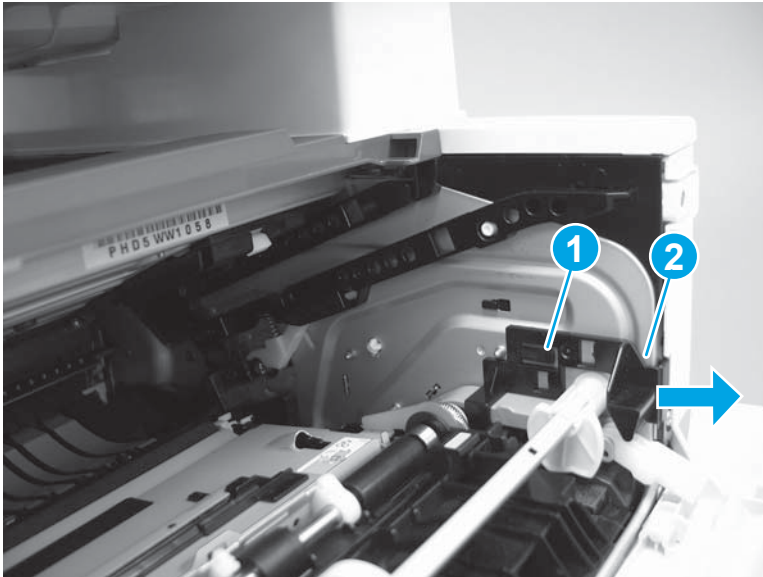

3. Remove the link arm (callout 1).

Figure 1-1852 Remove the link arm

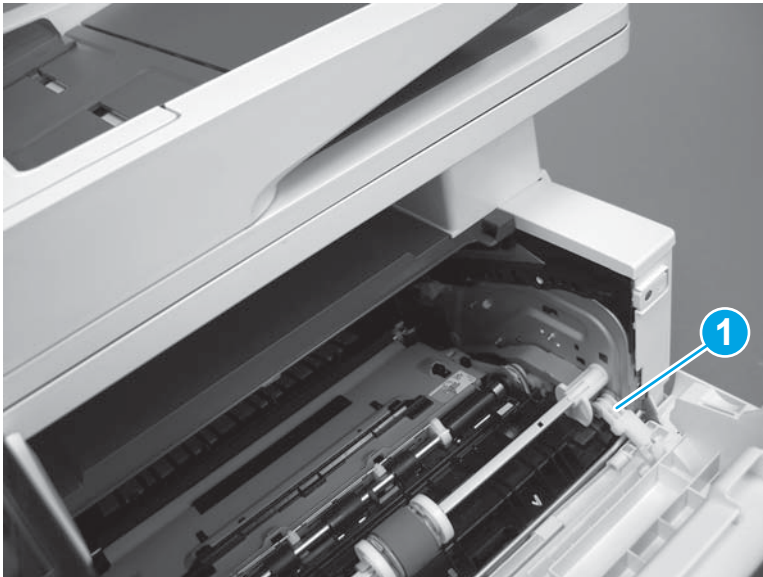

4. Slide the cartridge door assembly (callout 1) in the direction the arrow indicates and remove it.

Figure 1-1853 Remove the door

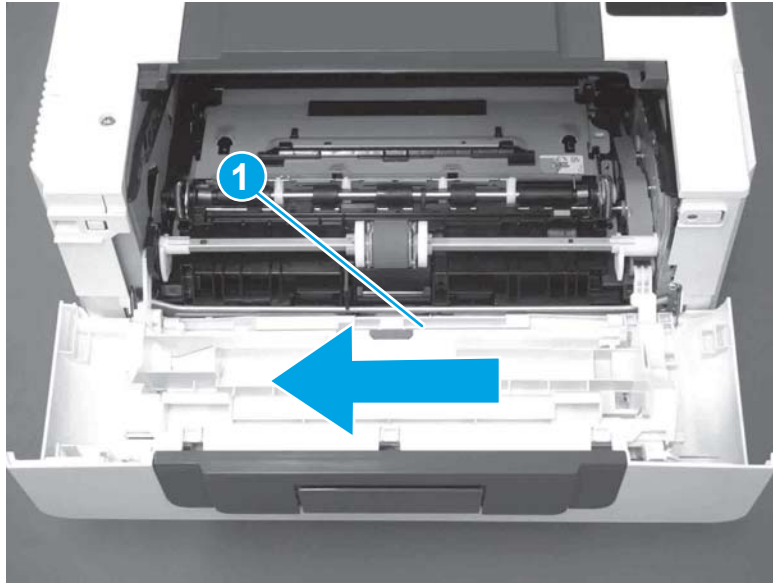

5. Remove the link (callout 1) from the cartridge door assembly (callout 2).

Figure 1-1854 Release the left-side retainer arm

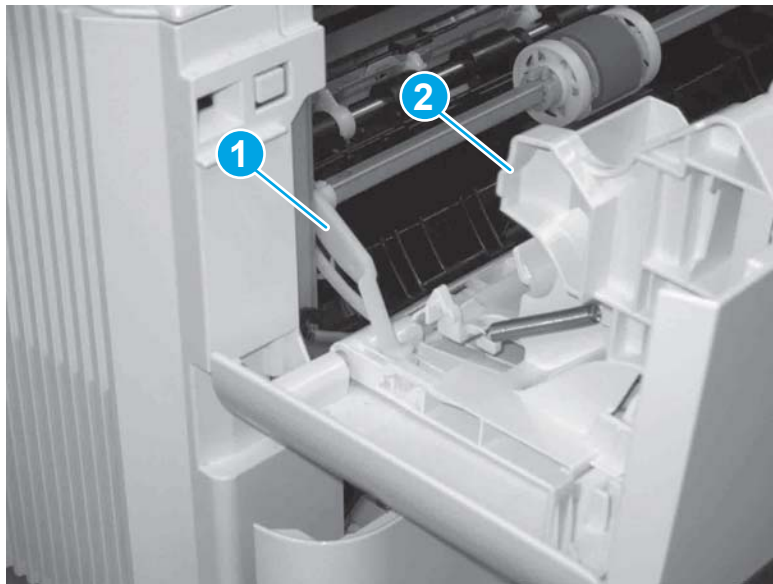

Step 3: Remove the left cover

1. Remove one screw (callout 1).

Figure 1-1855 Remove one screw



2. Open the rear door, release two bosses (callout 1), and then release three tabs (callout 2).

Figure 1-1856 Release two bosses and three tabs

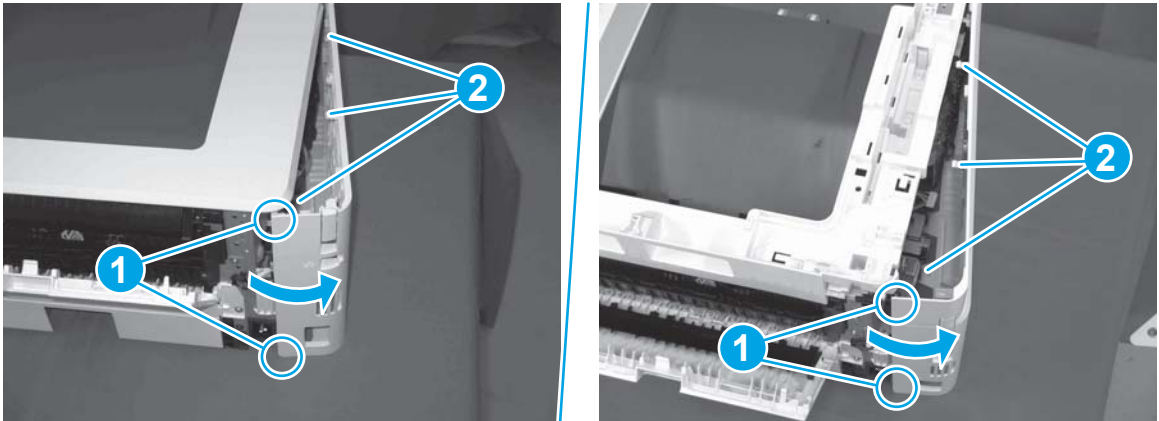

3. At the front of the printer, do one of the following:
 - **M403/M402:** Release two bosses (callout 1), and then remove the cover (callout 2).
 - **M427/M426:** Release one tab (callout 3), two bosses (callout 4), and then remove the cover (callout 5).

CAUTION: Be careful when releasing the upper bosses on the M427/M426 cover. One portion of the cover (callout 6) is fragile and is easily broken.

Figure 1-1857 Remove the cover

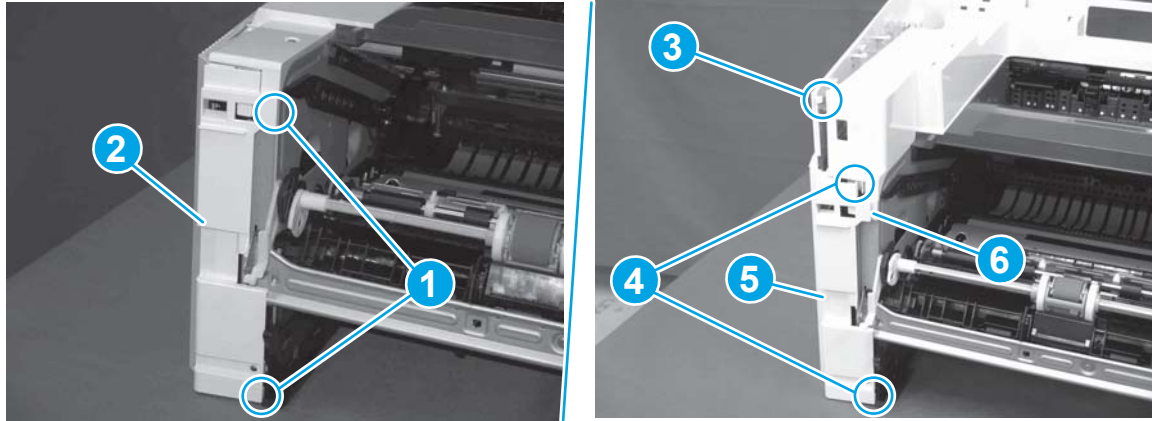

Step 4: Remove the right cover

1. Remove one screw (callout 1).

Figure 1-1858 Remove one screw



2. At the front of the printer, release two bosses (callout 1), and then release three tabs (callout 2).

Figure 1-1859 Release two bosses and three tabs

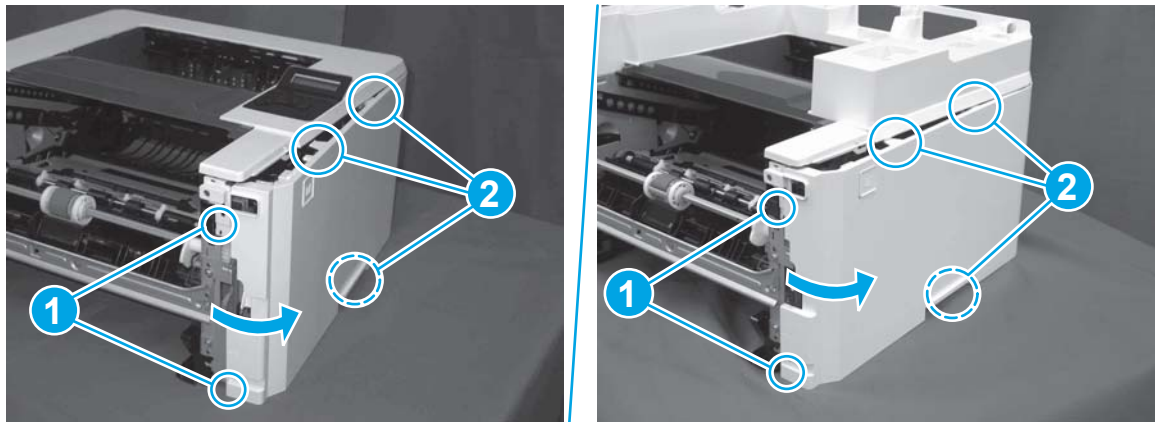

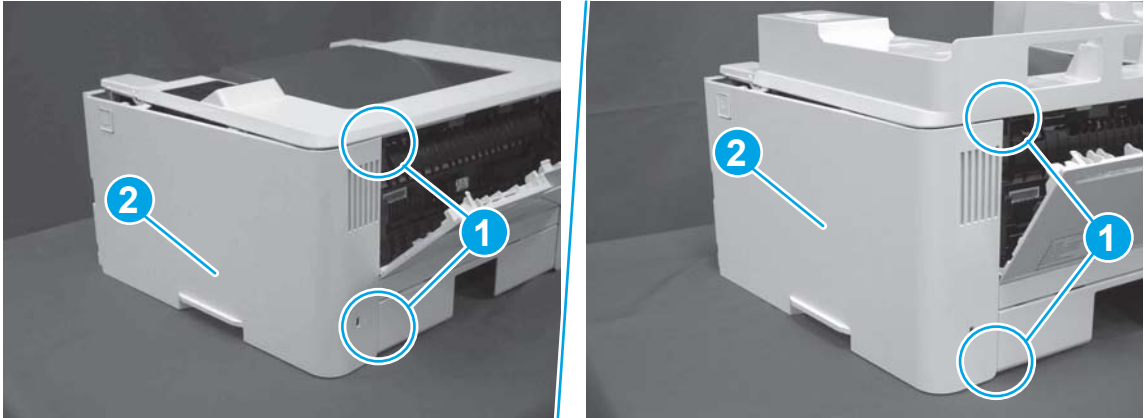

3. Open the rear door, release two bosses (callout 1), and then remove the cover (callout 2).

Figure 1-1860 Remove the cover



Step 5: Remove the integrated scanner assembly (M427/M246)

 **NOTE:** The step is for the M427/M426 printer. For the M403/M402, skip this step and go to [Step 8: Remove the top cover \(M403/M402\) on page 994](#).

 **NOTE:** M427/M426 models only. The integrated scanner assembly (ISA) includes the sub-scanner assembly (SSA) and the automatic document feeder (ADF).

1. Raise the ISA.

Figure 1-1861 Raise the ISA

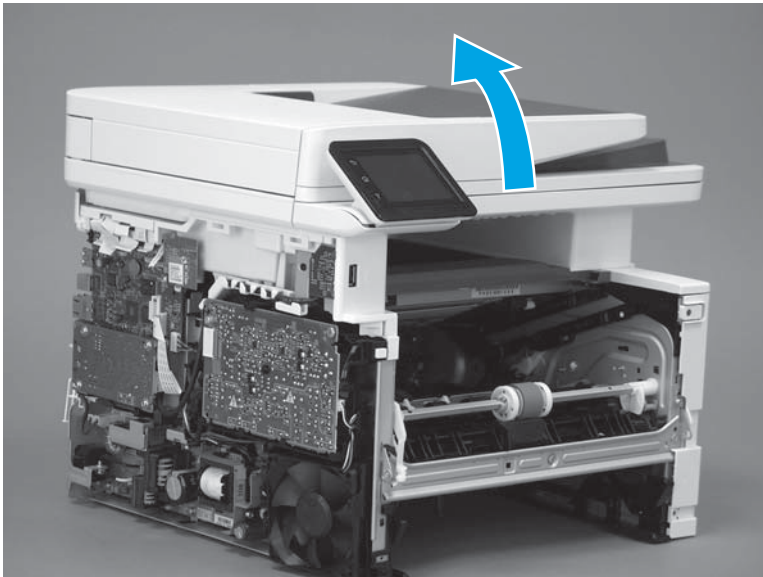

2. Release the ISA flat-flexible cable (FFC) cover (callout 1), and then remove it (callout 2).

Figure 1-1862 Remove the ISA FFC cover

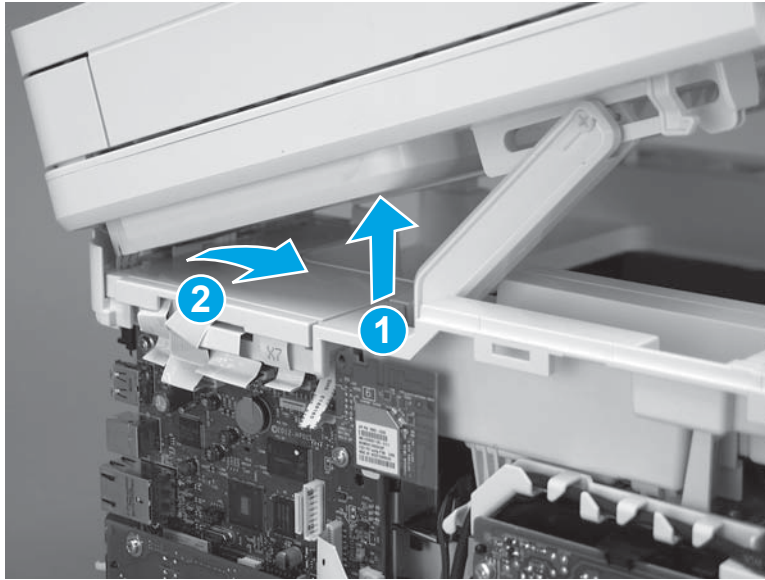

3. Disconnect three FFCs (callout 1), and then remove the ferrite (callout 2) from the holder.

CAUTION: The ferrite is not captive on the FFC. Do not lose the ferrite while handling the ISA.

Figure 1-1863 Disconnect three FFCs

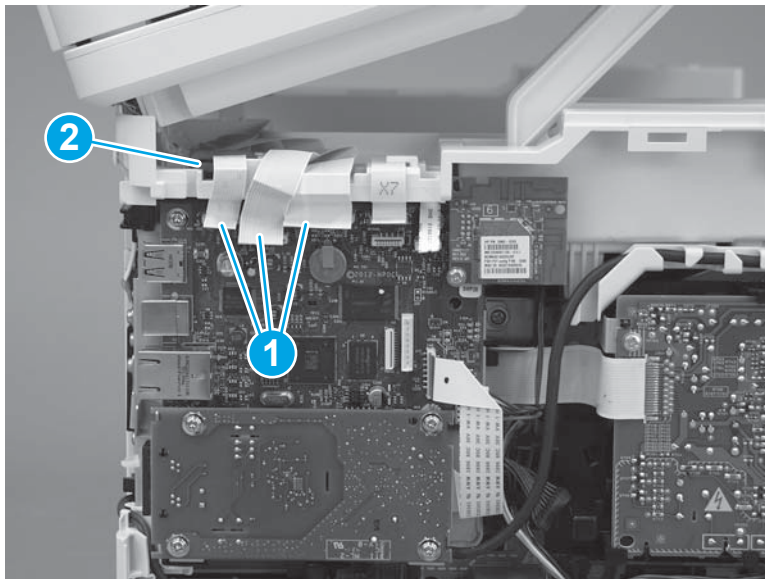

4. Remove one screw (callout 1).

Figure 1-1864 Remove one screw

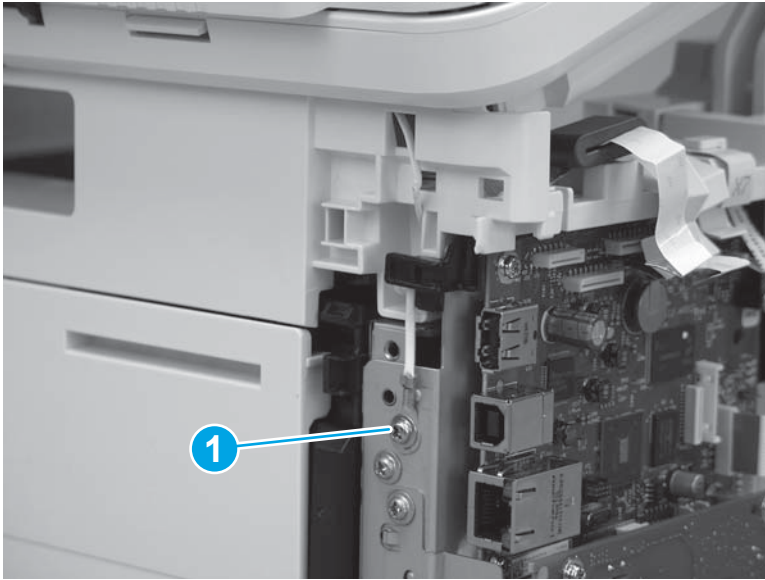

5. Pass the ground wire through the opening in the top cover.

Figure 1-1865 Pass the wire through the opening

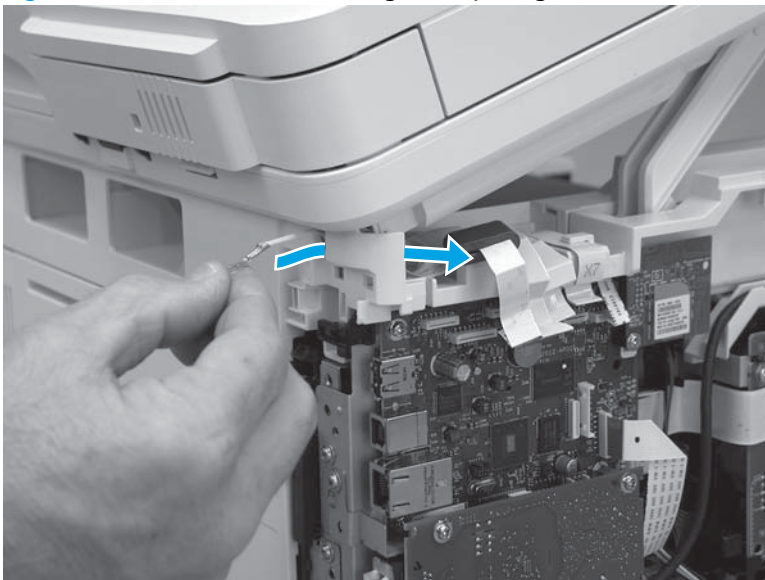

6. Release one tab (callout 1), and then rotate the ISA slider pin (callout 2) towards the front of the printer to release it.

Figure 1-1866 Release one tab and rotate the slider pin

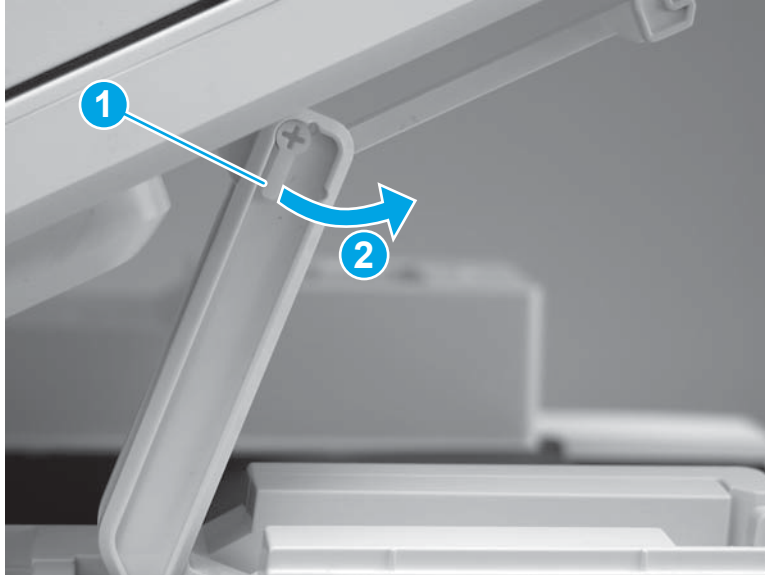

7. Remove the slider pin.

Figure 1-1867 Remove the slider pin

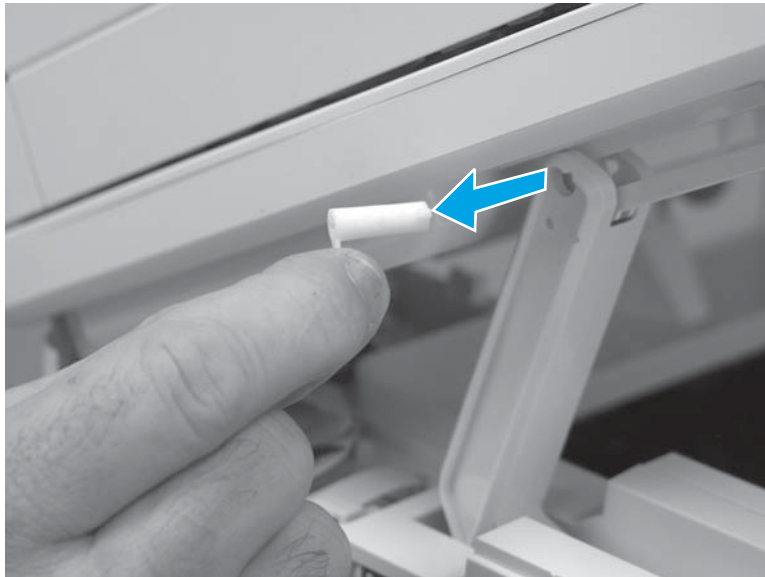

8. Rotate the ISA towards the rear of the printer until it stops.

Figure 1-1868 Rotate the ISA towards the rear of the printer



9. Slide the ISA as shown to release it.

Figure 1-1869 Release the ISA

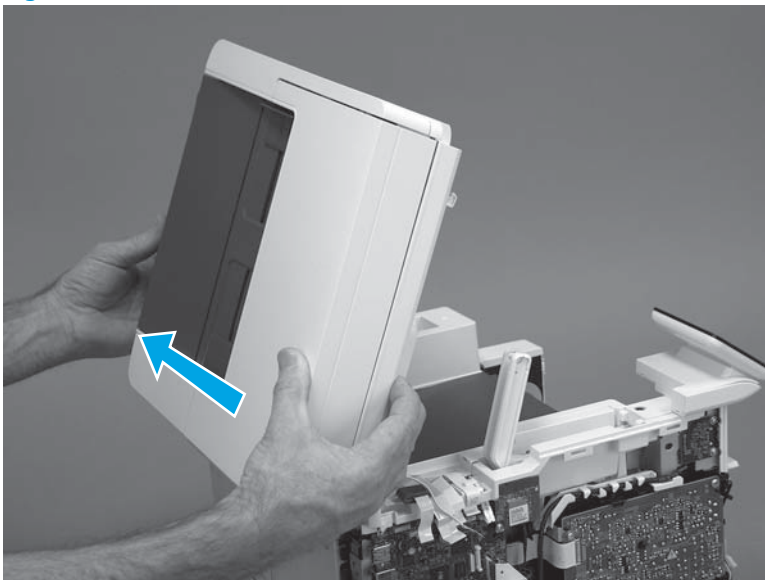

10. Remove the ISA.

Figure 1-1870 Remove the ISA

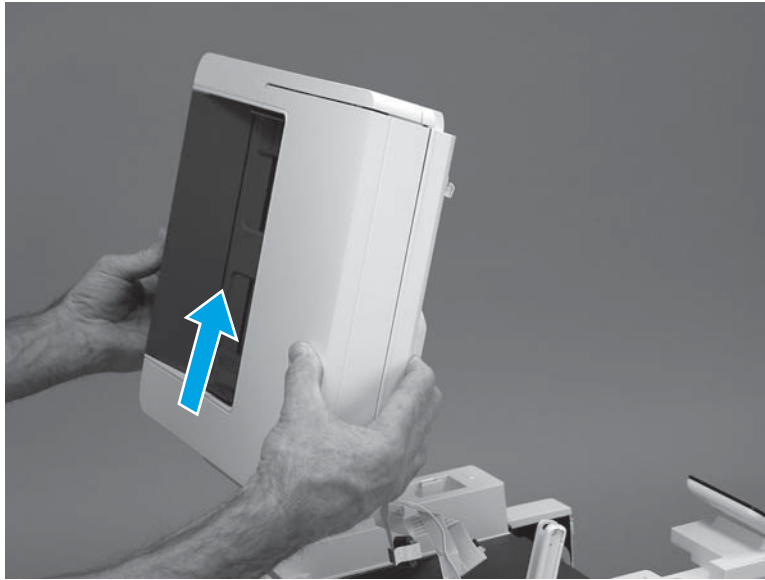

Step 6: Remove the control panel (M427/M246)

 **NOTE:** The step is for the M427/M426 printer. For the M403/M402, skip this step and go to [Step 8: Remove the top cover \(M403/M402\) on page 994](#).

1. Disconnect one FFC (callout 1; J114), and then release the FFC from the retainer (callout 2).

Figure 1-1871 Disconnect one connector

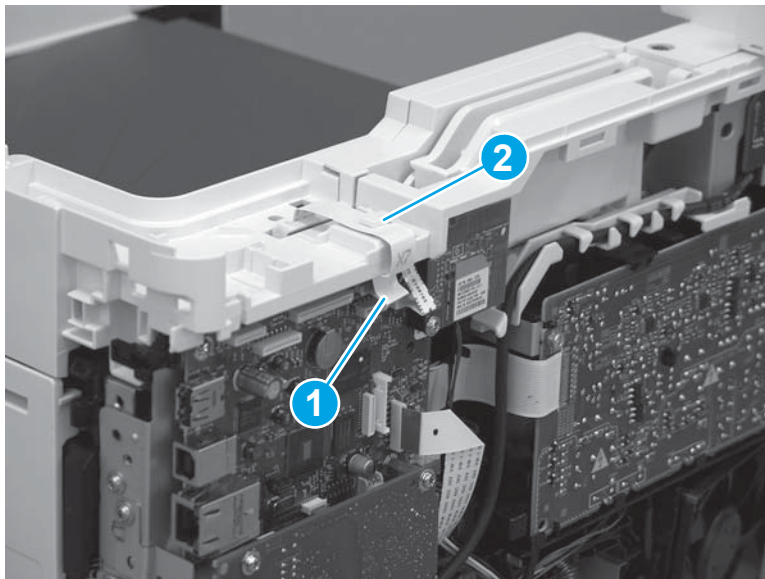

2. Remove one screw (callout 1).

Figure 1-1872 Remove one screw

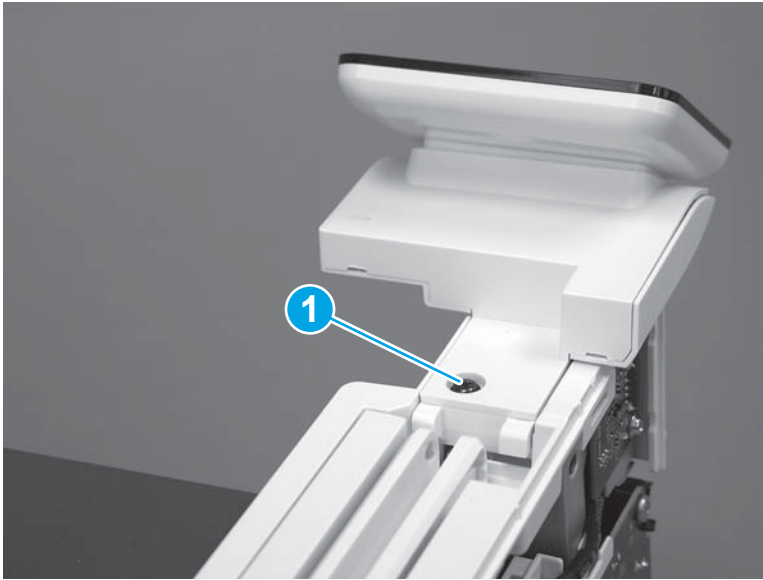

3. Use a small flat-blade screwdriver to release two tabs (callout 1) on the control-panel cable cover.

Figure 1-1873 Release two tabs

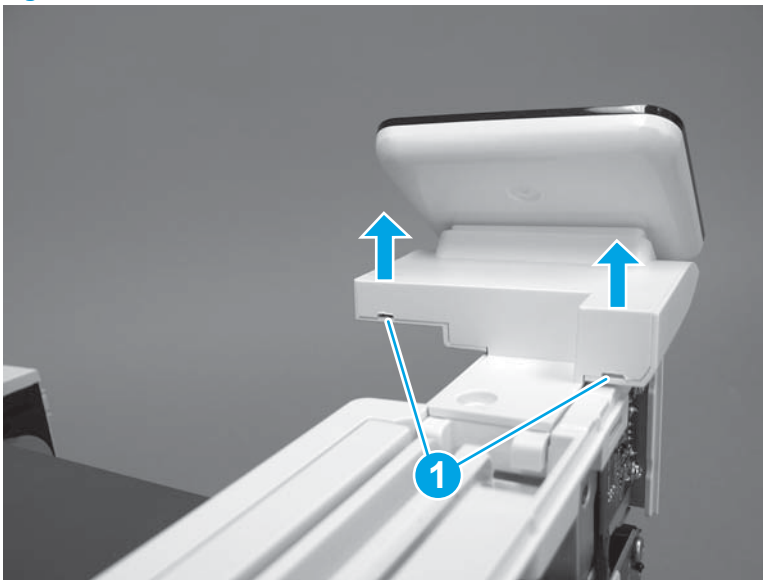

4. Remove the control-panel cable cover.

Figure 1-1874 Remove the cover

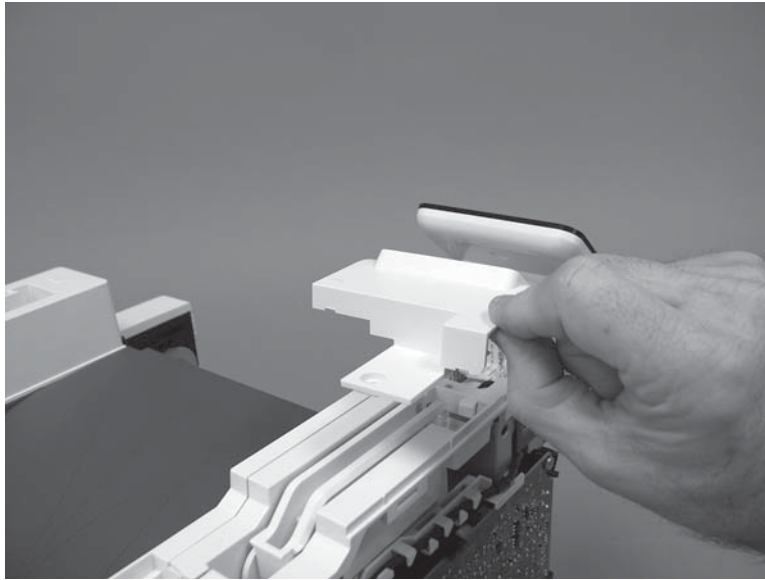

5. Remove one grounding screw (callout 1), and then move the ground cable (callout 2) out of the way.

Figure 1-1875 Remove one screw

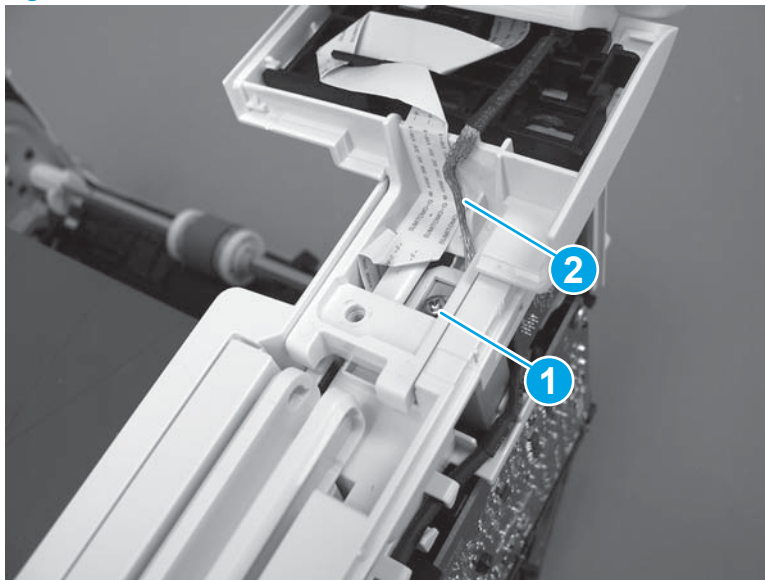

6. Move the FFC out of the way, and then remove two screws (callout 1).

Figure 1-1876 Remove two screws

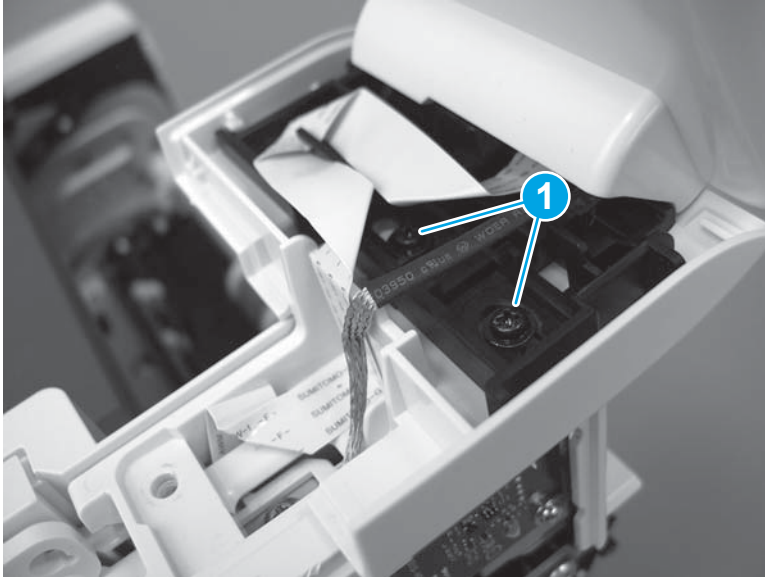

7. Slightly lift up the control-panel assembly to separate it from the top cover.

CAUTION: The control panel assembly is still connected to the printer by the FFC. Do not attempt to completely remove the assembly.

Figure 1-1877 Lift up the control-panel assembly

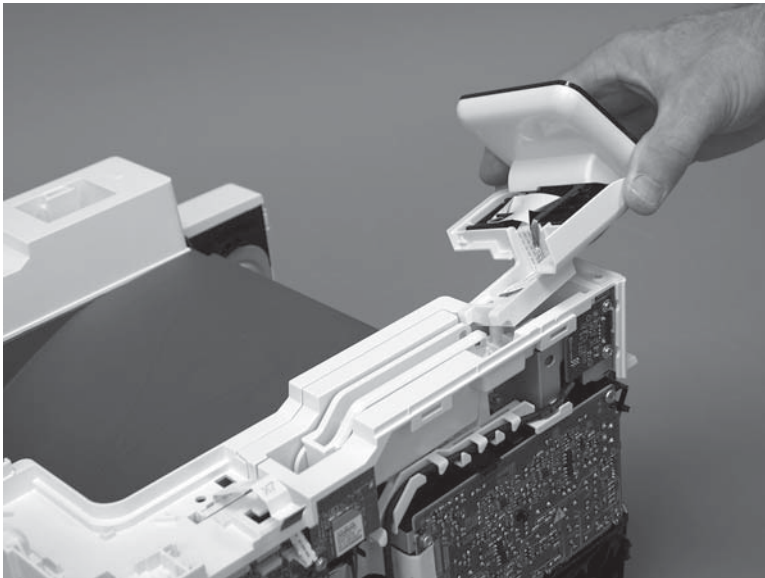

8. Lift up the control-panel FFC cover to remove the control-panel assembly.

Figure 1-1878 Remove the control-panel assembly

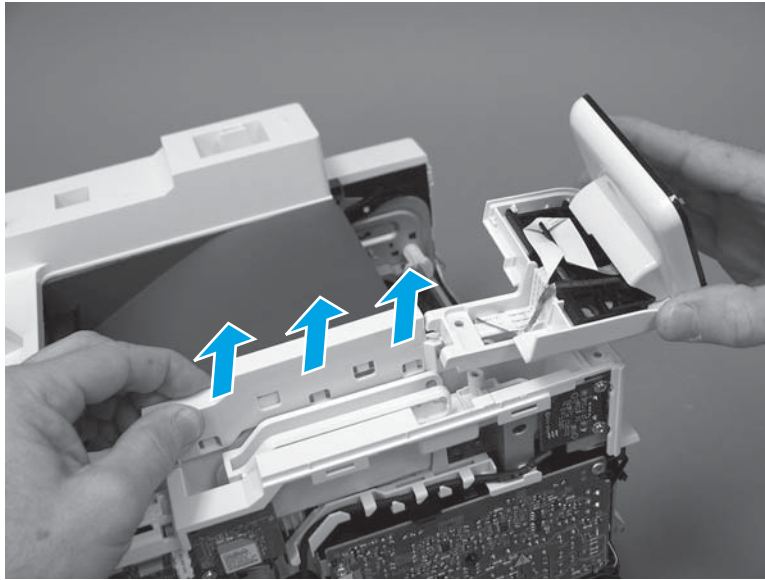

Step 7: Remove the top cover (M427/M426)

 **NOTE:** The step is for the M427/M426 printer. For the M403/M402, skip this step and go to [Step 8: Remove the top cover \(M403/M402\) on page 994](#).

1. Release the USB cable (callout 1) from the cable guide.

Figure 1-1879 Remove the USB cable

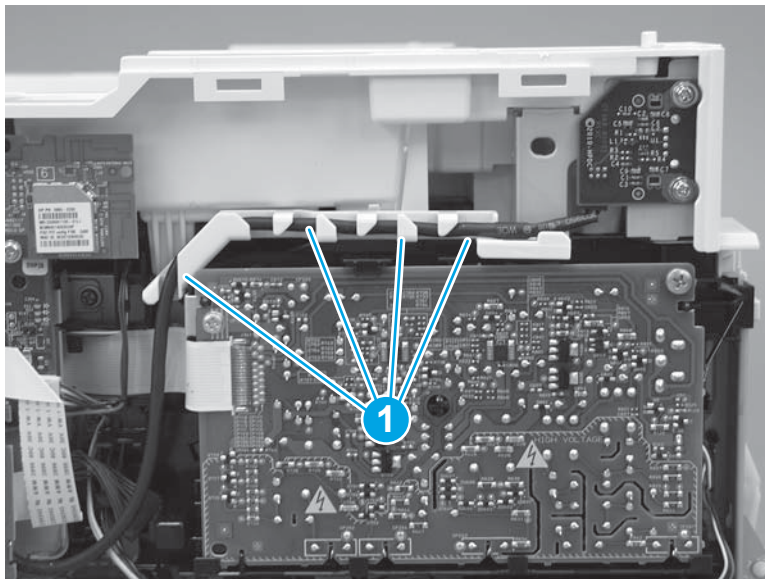

2. Remove five screws (callout 1), release four bosses (callout 2), and then remove the top cover (callout 3).

Figure 1-1880 Remove the cover

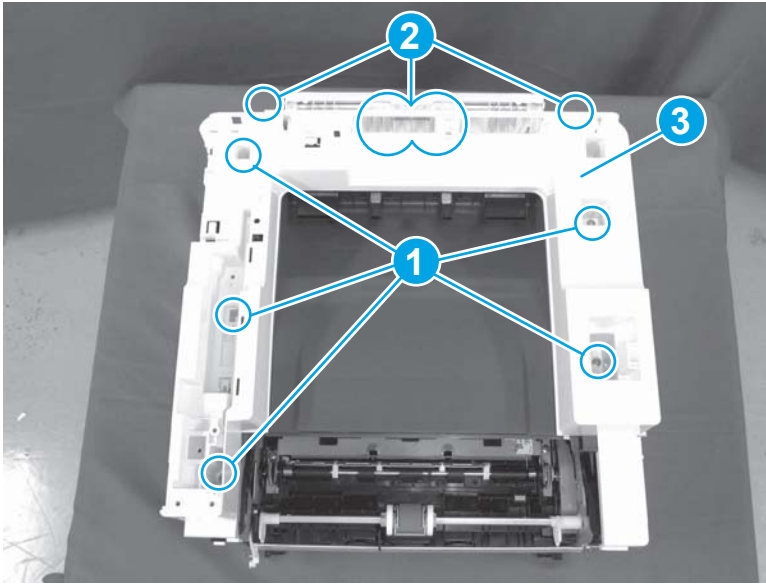

Step 8: Remove the top cover (M403/M402)

 **NOTE:** The step is for the M403/M402 printer. For the M427/M426, skip this step and go to [Step 9: Remove the paper delivery tray \(output bin\) on page 995](#).

1. Remove one screw (callout 1).

Figure 1-1881 Remove one screw



2. At the right side of the printer, release the one boss (callout 1), and then release one tab (callout 2).

Figure 1-1882 Release one boss and one tab

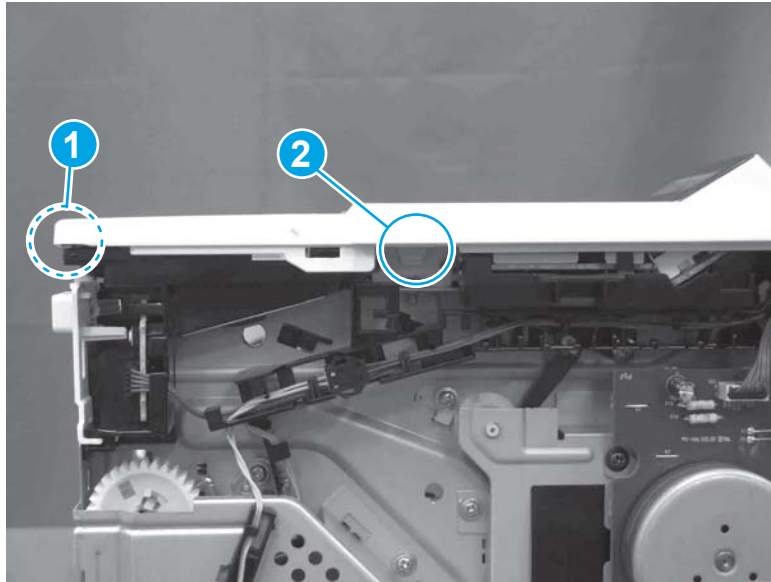

3. Release four tabs (callout 1), release four bosses (callout 2), and then remove the top cover (callout 3).



 **TIP:** Open the rear door to make releasing the bosses (callout 3) easier.

Figure 1-1883 Remove the cover

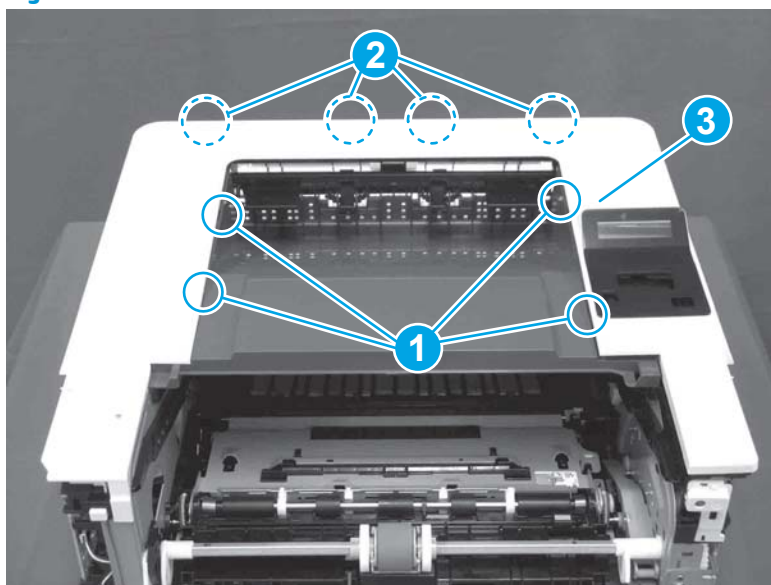

Step 9: Remove the paper delivery tray (output bin)

 **NOTE:** This procedure shows the M403/M402 model, however, the paper delivery tray (output bin) removal is similar for the M427/M426 printer.

- ▲ Release two bosses (callout 1), release two tabs (callout 2), and then remove the paper delivery tray (output bin; callout 3).

Figure 1-1884 Release two tabs

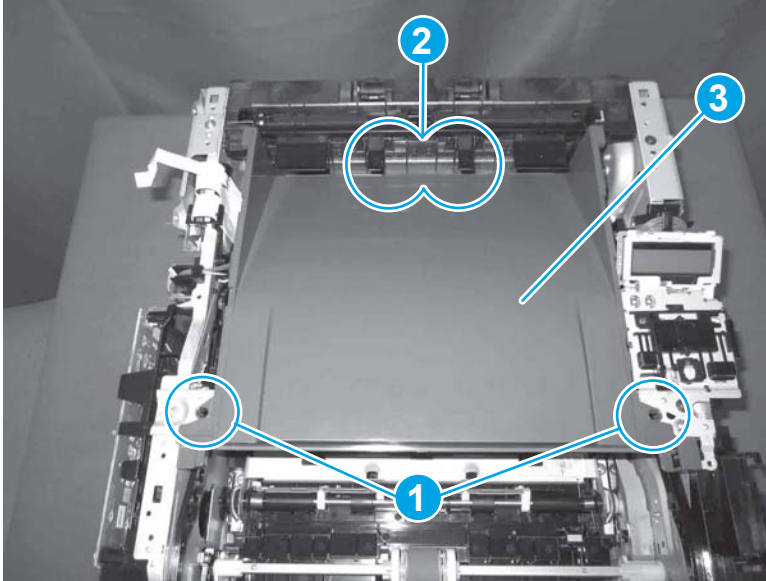

Step 10: Remove the fan (FM1)

1. Disconnect one connector (callout 1), and then release the wire harness from the retainer (callout 2).

Figure 1-1885 Disconnect one connector

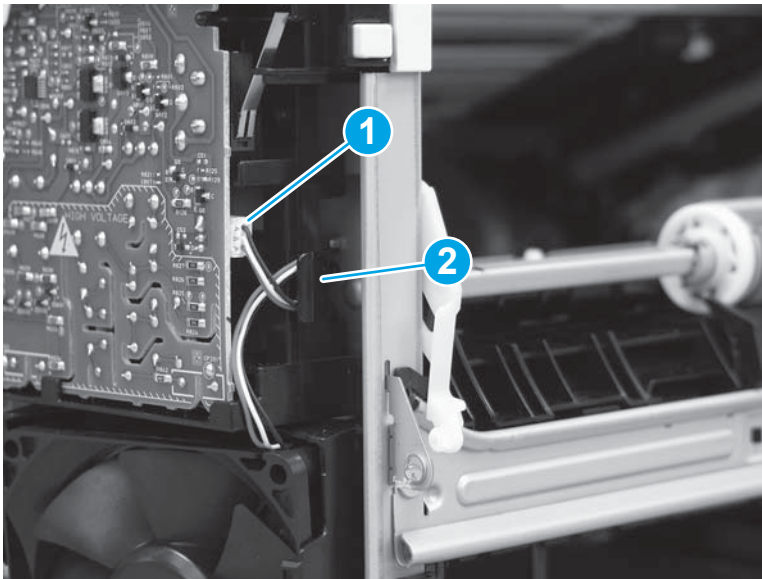

2. Release two tabs (callout 1).

Figure 1-1886 Release two tabs

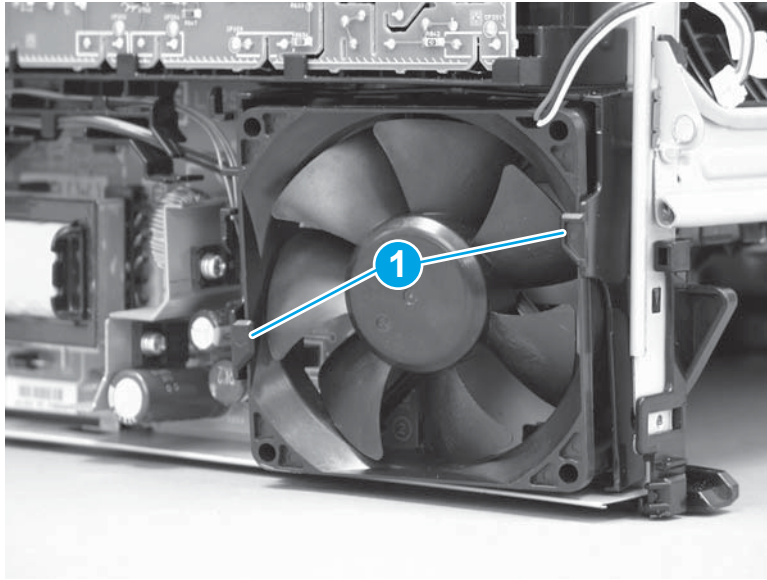

3. Remove the fan.

Figure 1-1887 Remove the fan

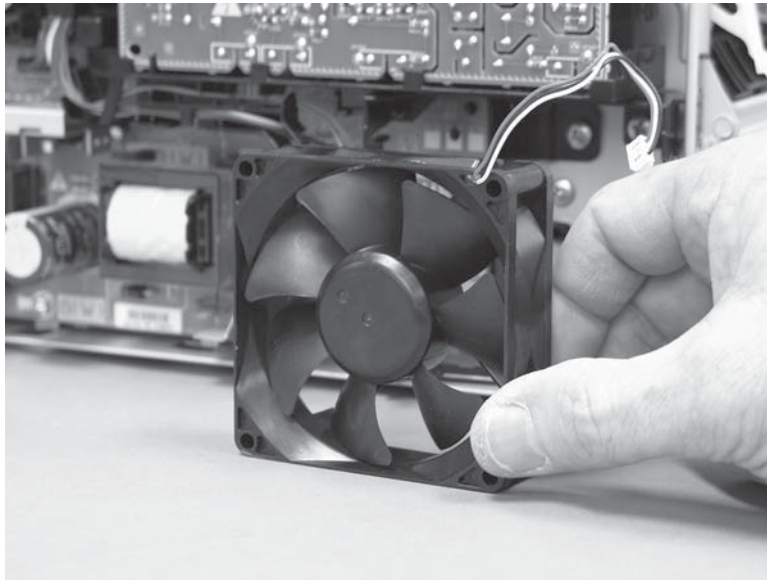

Step 11: Remove the sheet-metal formatter bracket and formatter PCA

 **NOTE:** Disconnect any remaining formatter PCA FFCs or wire-harness connectors.

1. **M427/M426 only:** Remove the guide (callout 1).

Figure 1-1888 Remove the guide

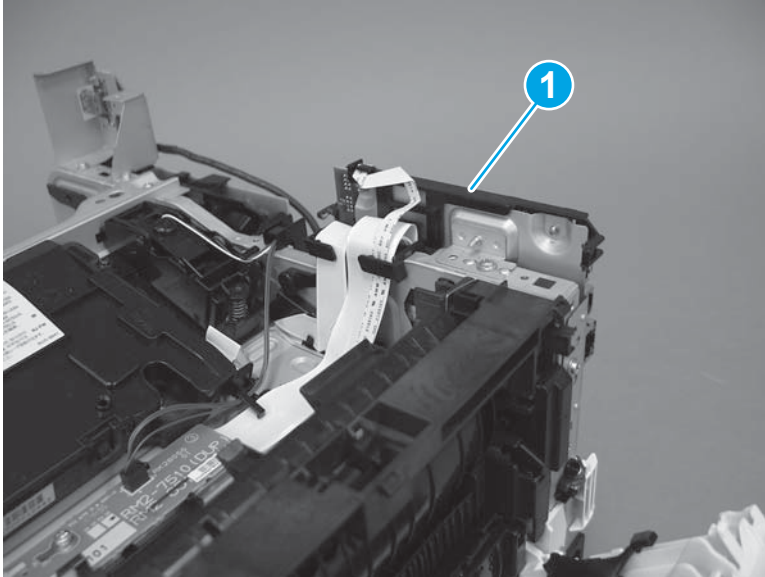

2. Remove two screws (callout 1).

Figure 1-1889 Remove two screws

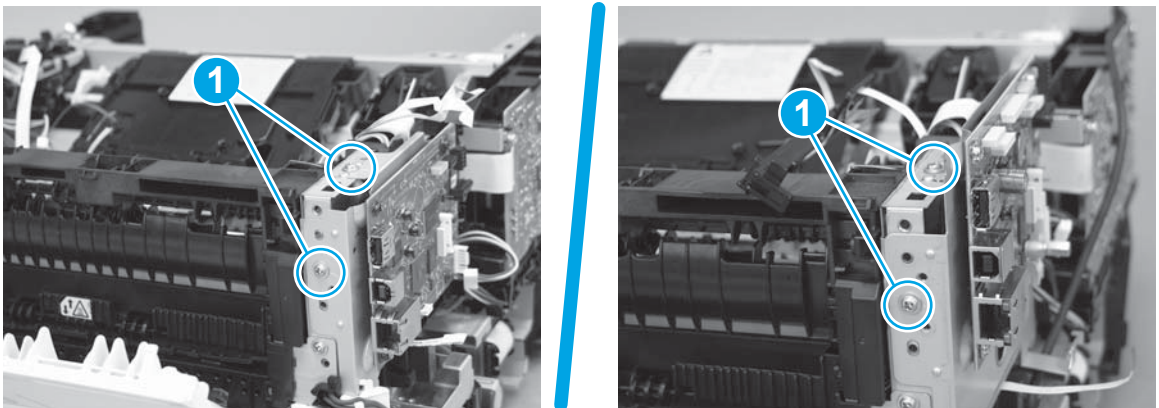

3. Disconnect one connector (callout 1), and then release the wire harness from the guide (callout 2).

Figure 1-1890 Disconnect one connector

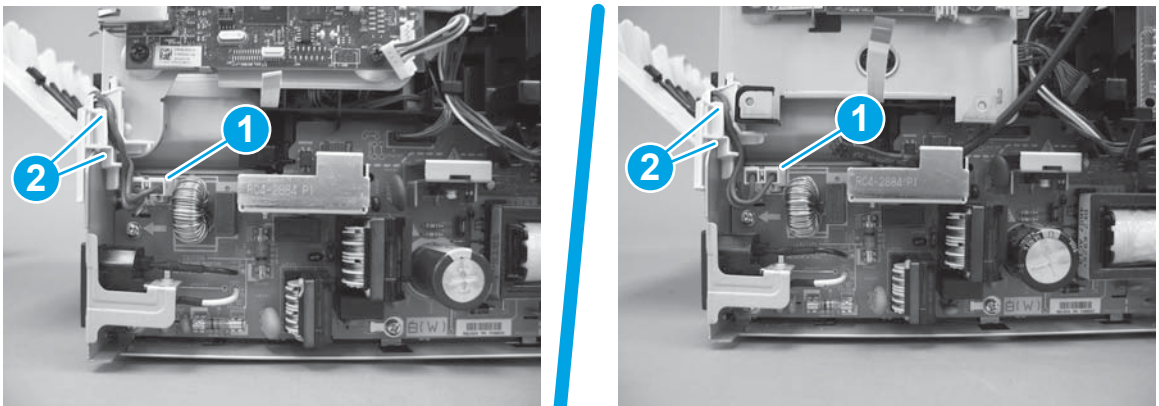

4. Remove the guide (callout 1).

Figure 1-1891 Remove the guide

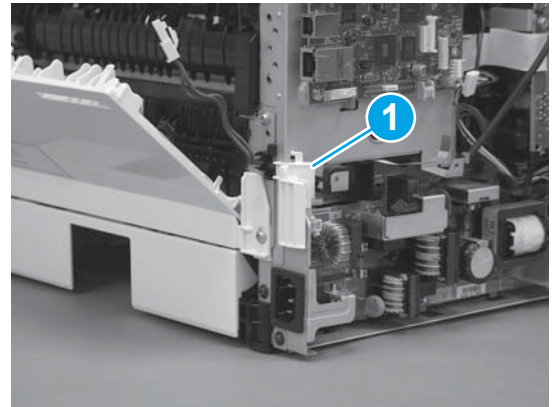
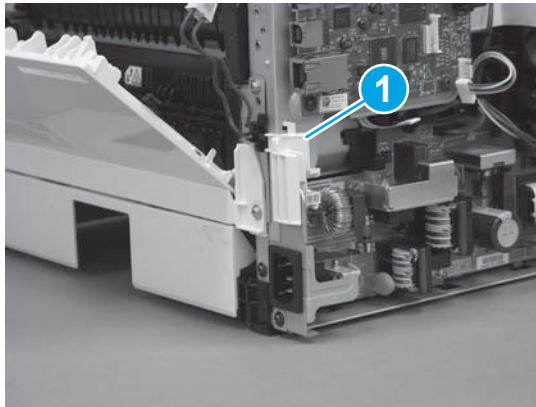

5. Remove three screws (callout 1).

Figure 1-1892 Remove three screws

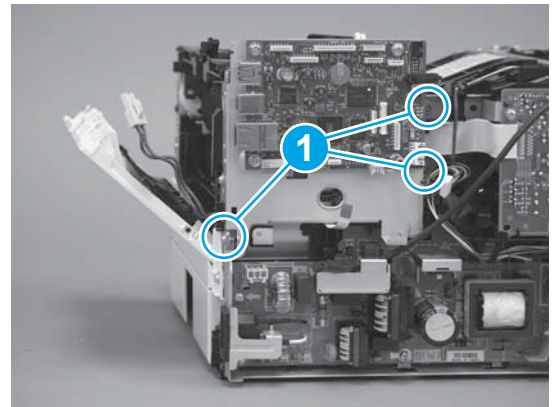
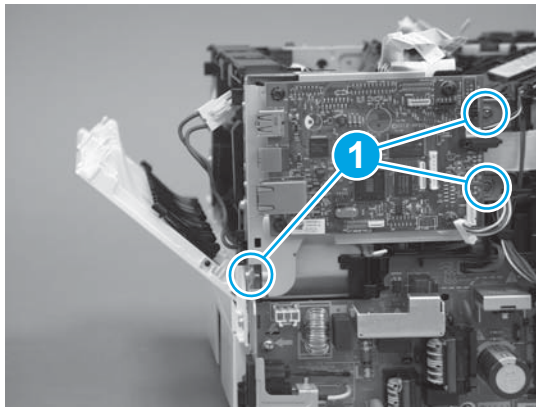

6. Remove the sheet-metal bracket and formatter PCA.

Figure 1-1893 Remove the bracket

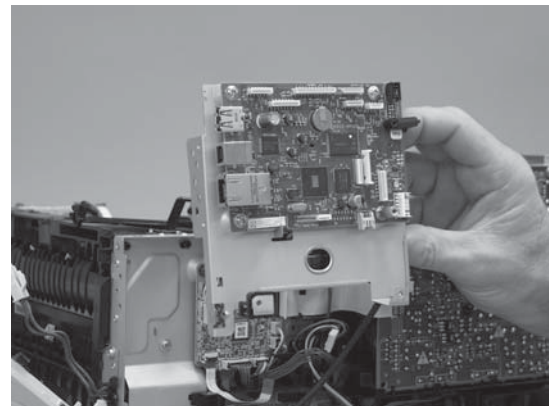
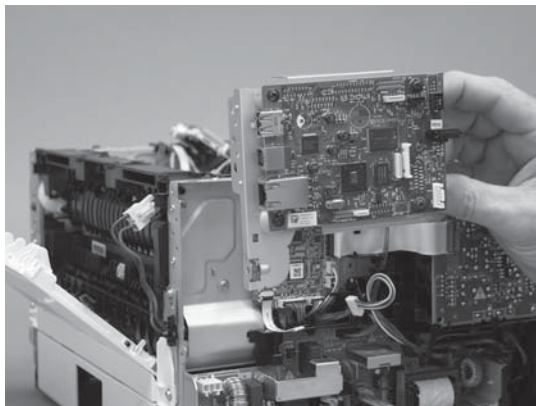

Step 12: Remove the LVPS

1. Disconnect two connectors (callout 1) on the LVPS, and then release the wire harnesses from the guides (callout 2).

Figure 1-1894 Disconnect two connectors

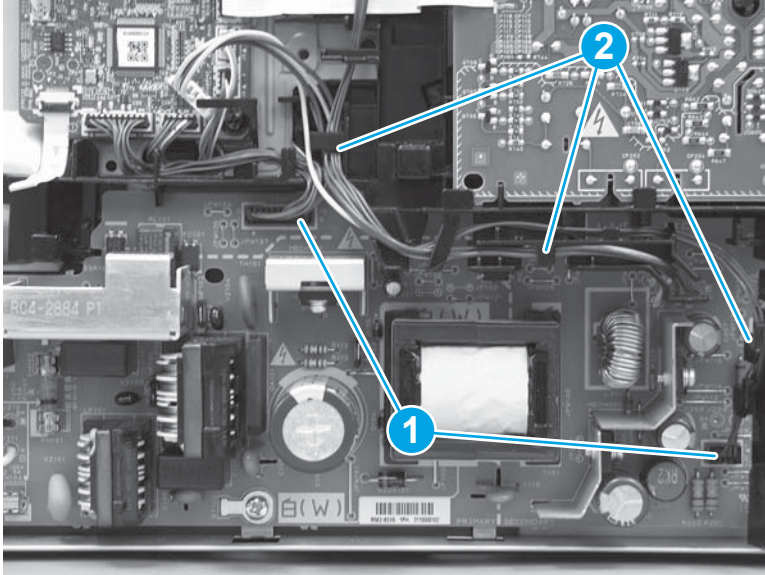

2. Remove one screw (callout 1).

Figure 1-1895 Remove one screw

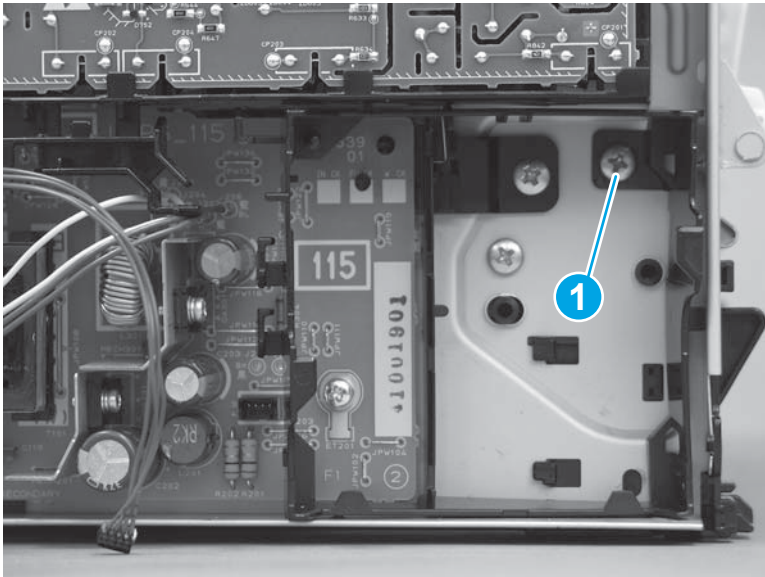

3. Release one tab at the top-left side of the fan holder (callout 1), and then rotate the top-left side corner of the holder away from the printer.

 **Reinstallation tip:** Use a flat-blade screwdriver to slightly flex the top of the holder down to make it easier to disengage this tab.

Figure 1-1896 Release one tab



4. Slightly flex the right side of the holder to release one tab (callout 1), and then rotate the top of the holder away from the printer (callout 2).

Figure 1-1897 Release one tab

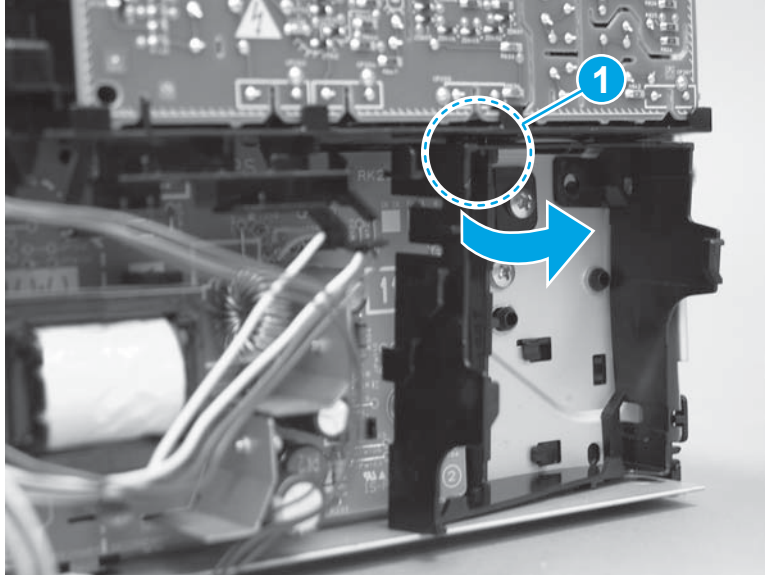
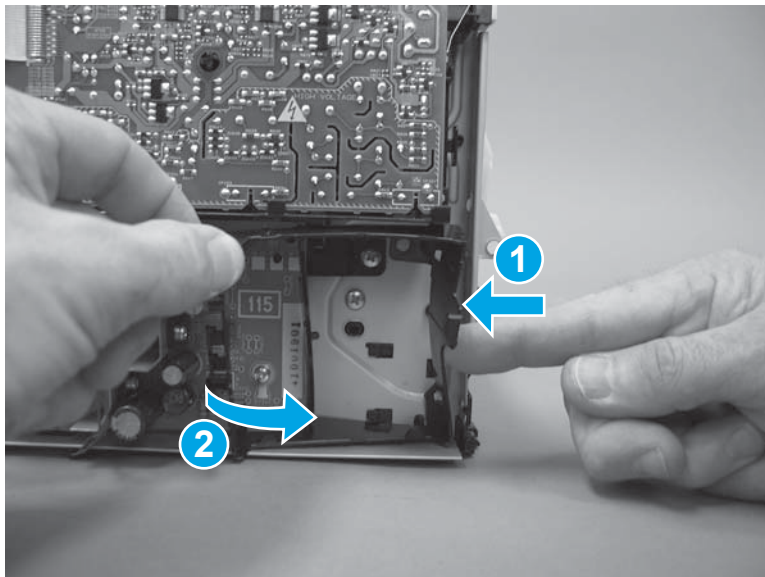

5. Lift the holder up to release two alignment tabs on the bottom of the holder, and then remove the holder.

Figure 1-1898 Remove the holder

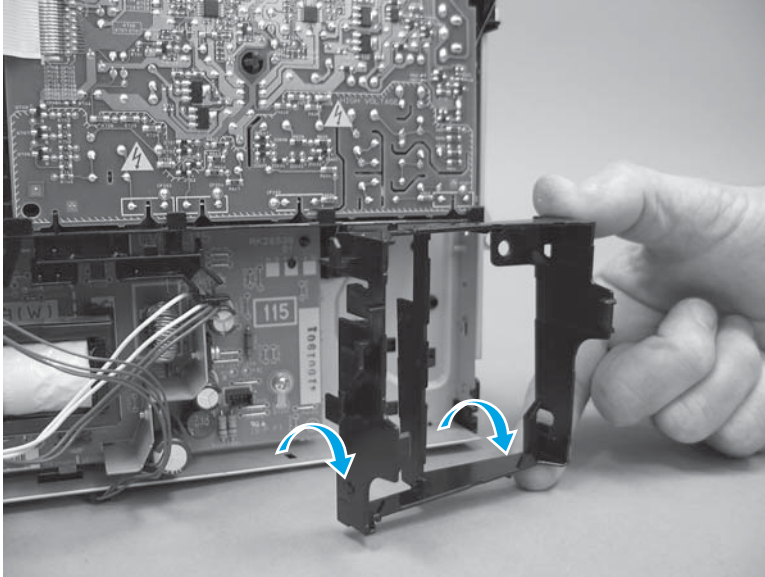

6. Remove two screws (callout 1).

Figure 1-1899 Remove two screws

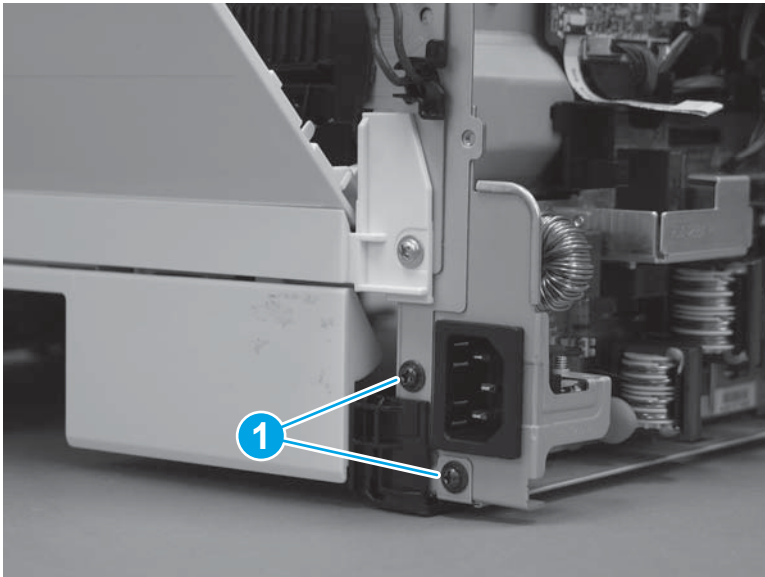

7. Remove three screws (callout 1).

Figure 1-1900 Remove three screws

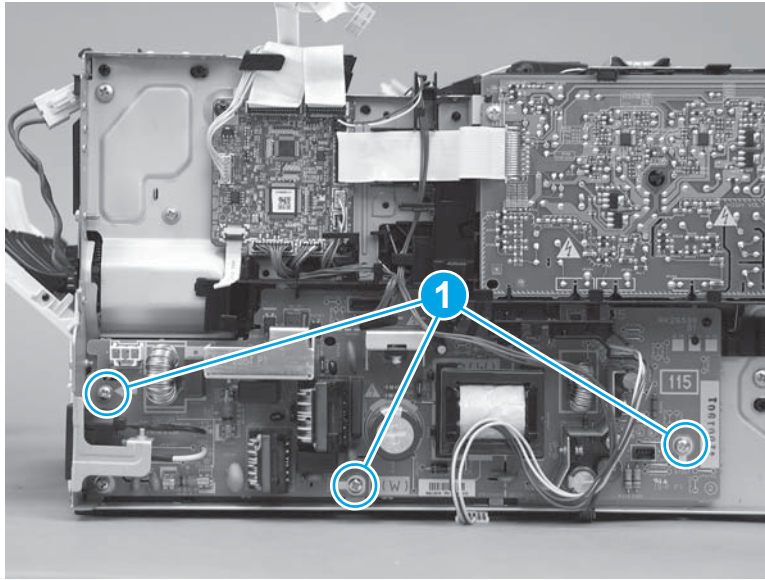

8. Rotate the bottom of the LVPS away from the printer, and then remove the LVPS.

Figure 1-1901 Remove the LVPS

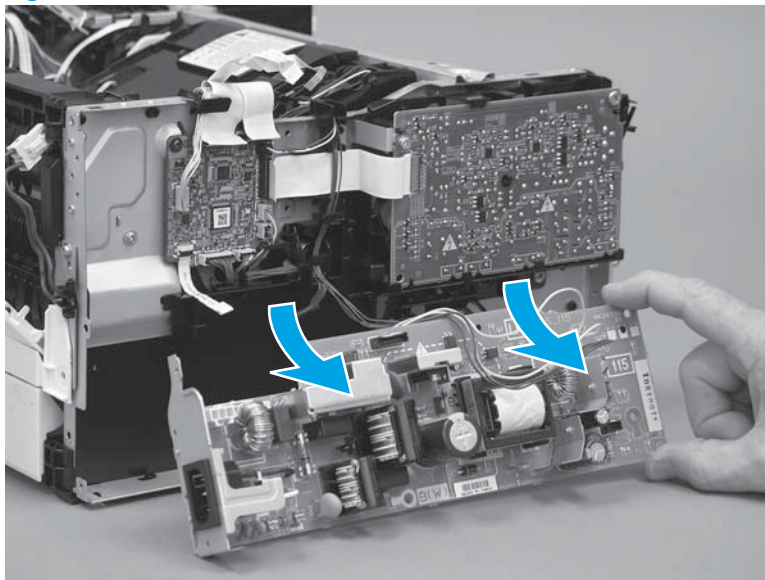

Step 13: Unpack the replacement assembly

Unpack the replacement part from the packaging.

<http://www8.hp.com/us/en/hp-information/environment/product-recycling.html>

 **NOTE:** HP recommends responsible disposal of the defective part.

Figure 1-1902 Recycle and unpack

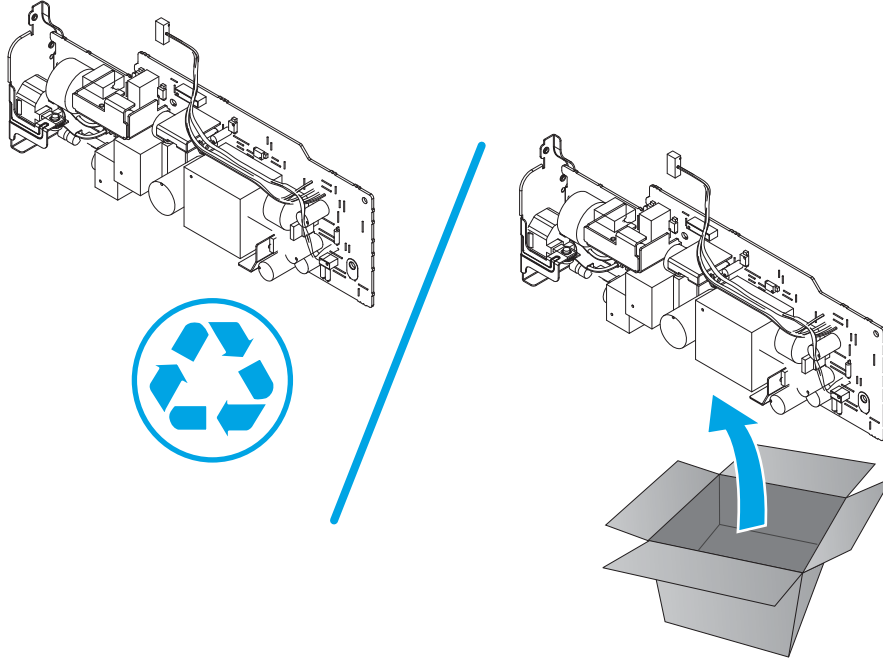

Step 14: Install the LVPS

1. Position the top of LVPS in the printer, and then rotate the bottom toward the printer to install the LVPS.

Figure 1-1903 Install the LVPS

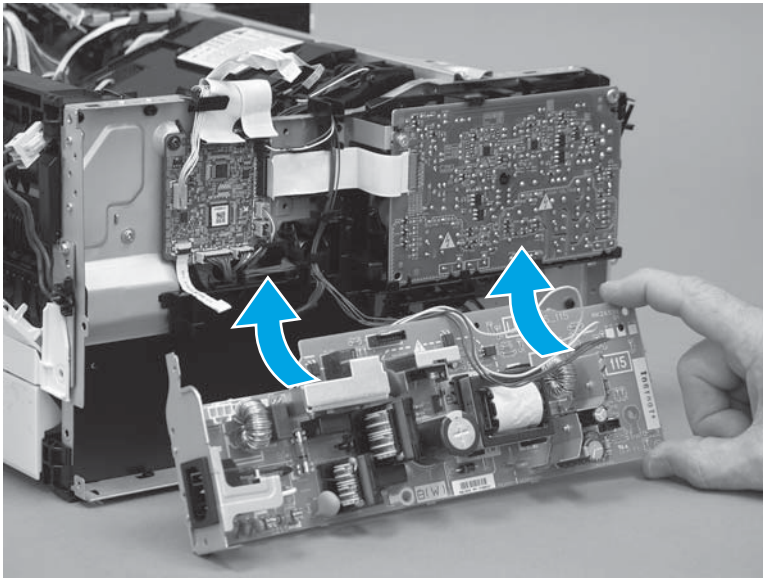

2. Install three screws (callout 1).

Figure 1-1904 Install three screws

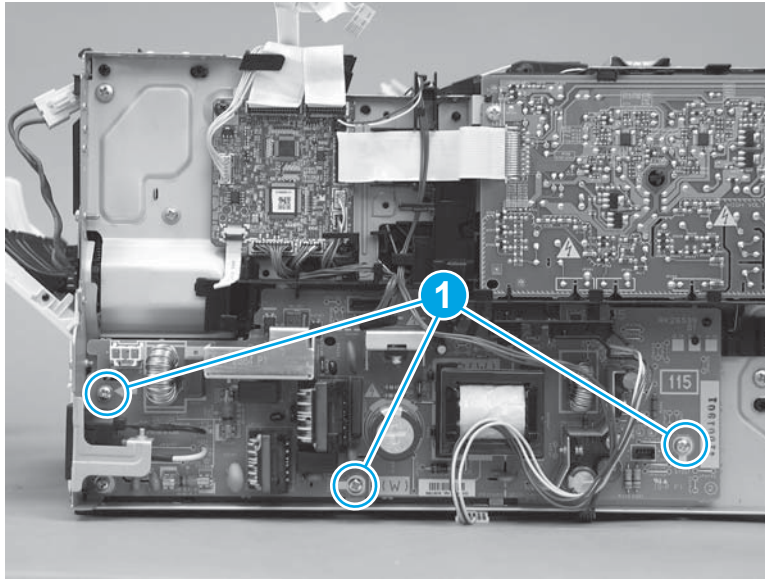

3. Install two screws (callout 1).

Figure 1-1905 Install two screws

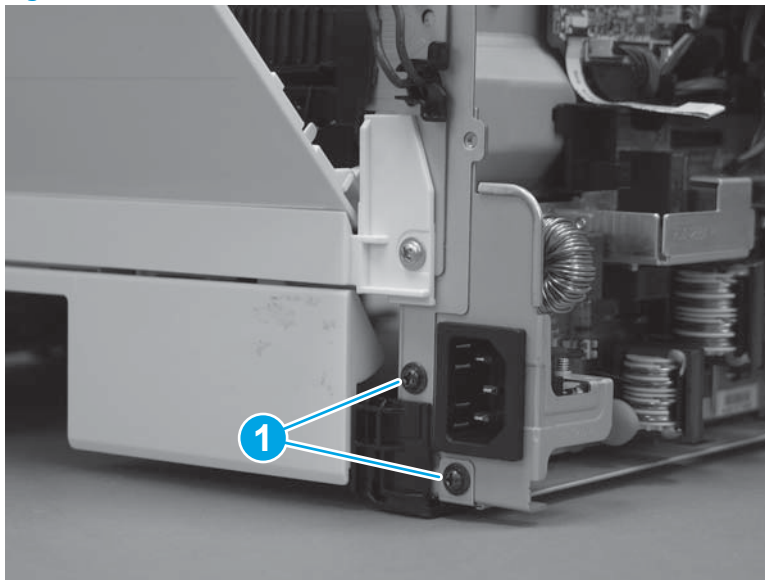

4. Position the bottom edge of the holder on the chassis—engage the two alignment tabs on the bottom of the holder with the slots in the chassis.

Figure 1-1906 Install the holder

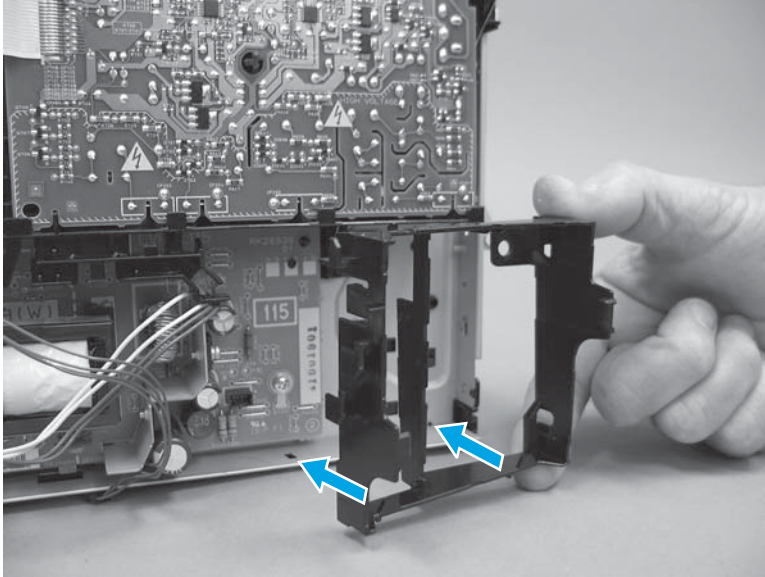

5. Rotate the top of the holder toward the printer (callout 1), and then engage one tab on the right side of the holder (callout 2).

Figure 1-1907 Engage one tab

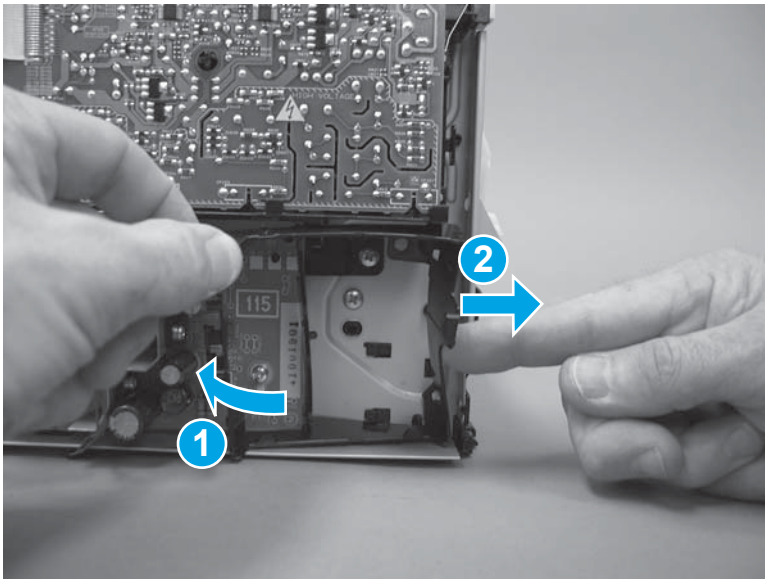

6. Rotate the top-left side corner of the holder toward the printer, and then engage one tab on the holder (callout 1).

 **Reinstallation tip:** Use a flat-blade screwdriver to slightly flex the top of the holder down to make it easier to engage this tab.

Figure 1-1908 Engage one tab



7. Install one screw (callout 1).

Figure 1-1909 Install one screw

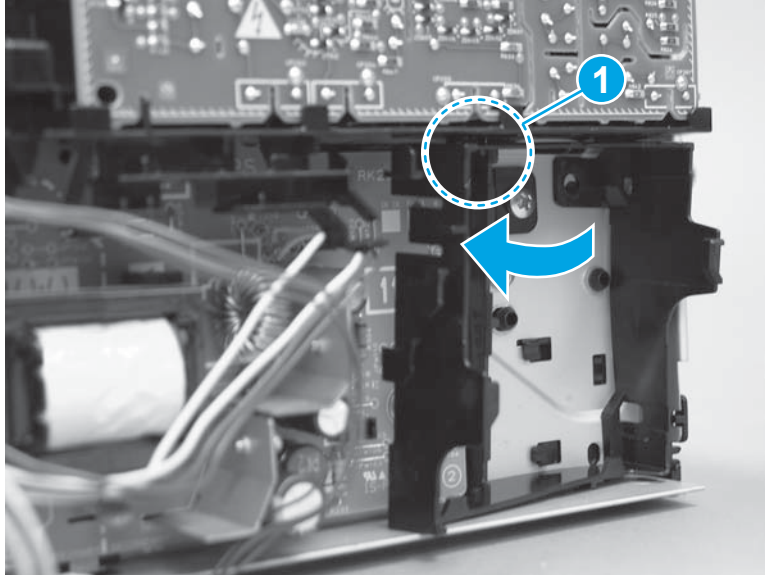
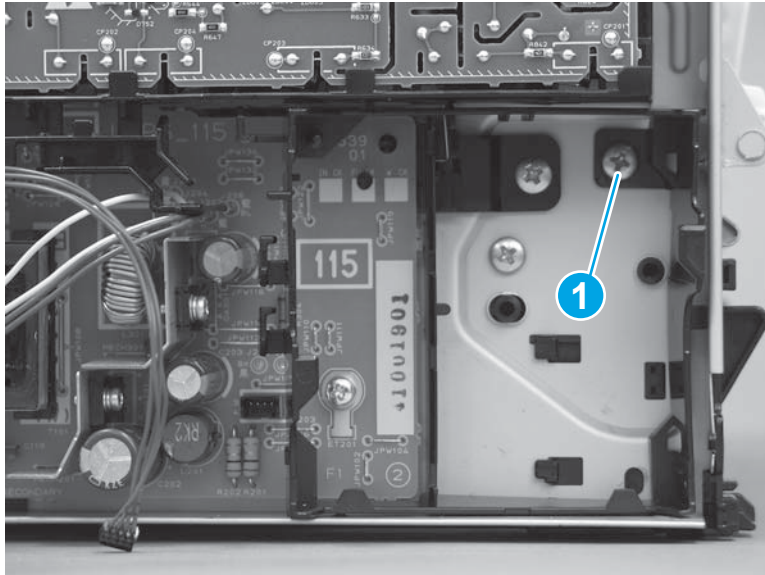

8. Install the wire harnesses in the guides (callout 1), and then connect two connectors (callout 2).

Figure 1-1910 Connect two connectors

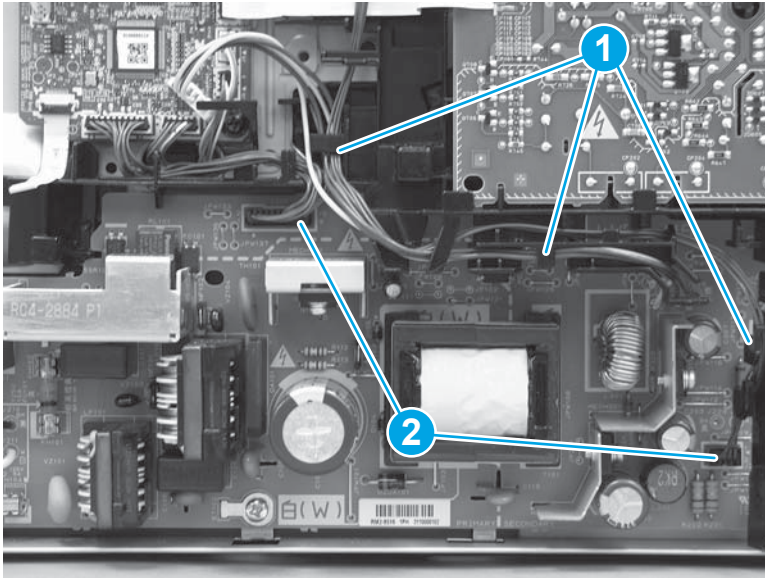

Step 15: Install the sheet-metal formatter bracket and formatter PCA



NOTE: Do not forget to connect any formatter PCA FFCs or wire-harness connectors that were disconnected when the bracket was removed.

1. Position the sheet-metal bracket and formatter PCA on the printer.

Figure 1-1911 Install the bracket

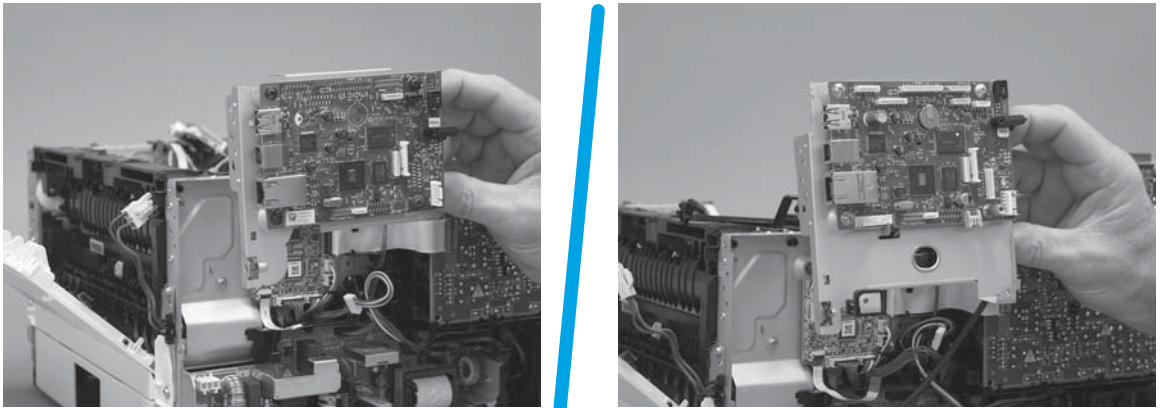

2. Install three screws (callout 1).

Figure 1-1912 Install three screws

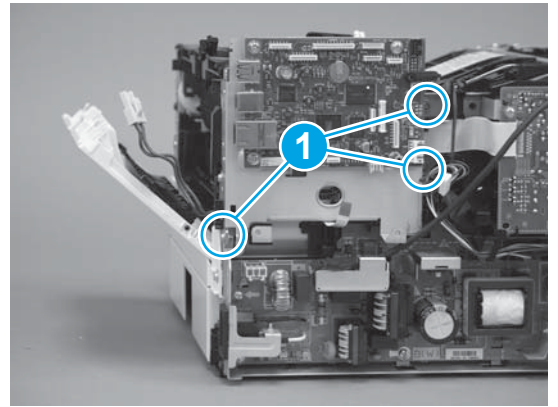
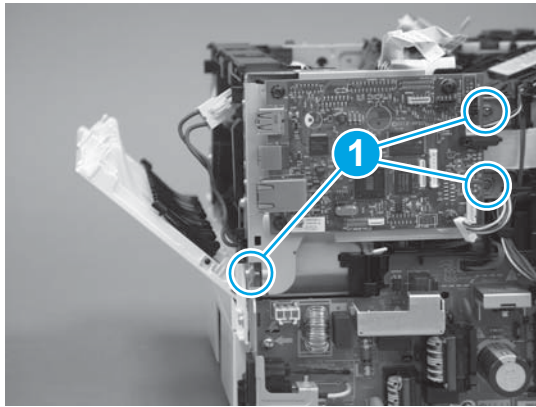

3. Install the guide (callout 1).

Figure 1-1913 Install the guide

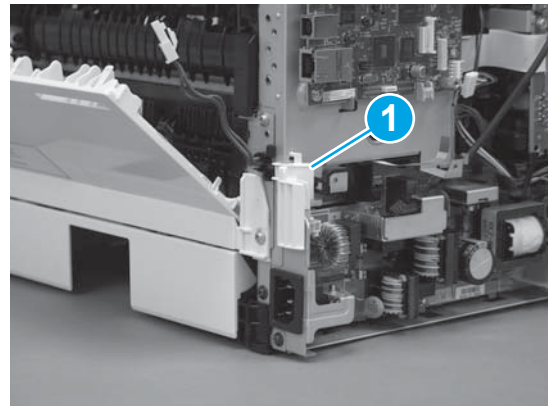
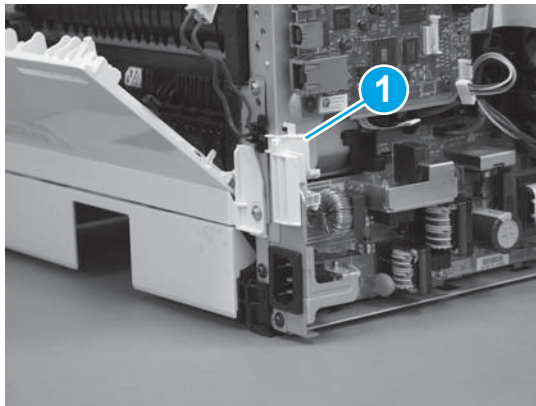

4. Connect one connector (callout 1), and then install the wire harness in the guide (callout 2).

Figure 1-1914 Connect one connector

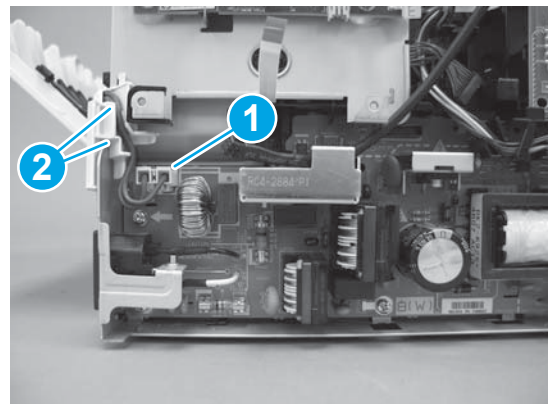
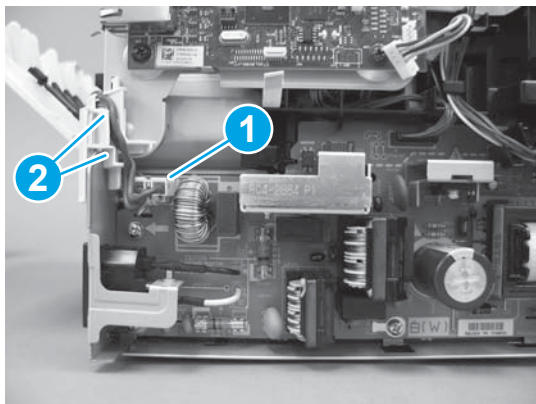

5. Install two screws (callout 1).

Figure 1-1915 Install two screws

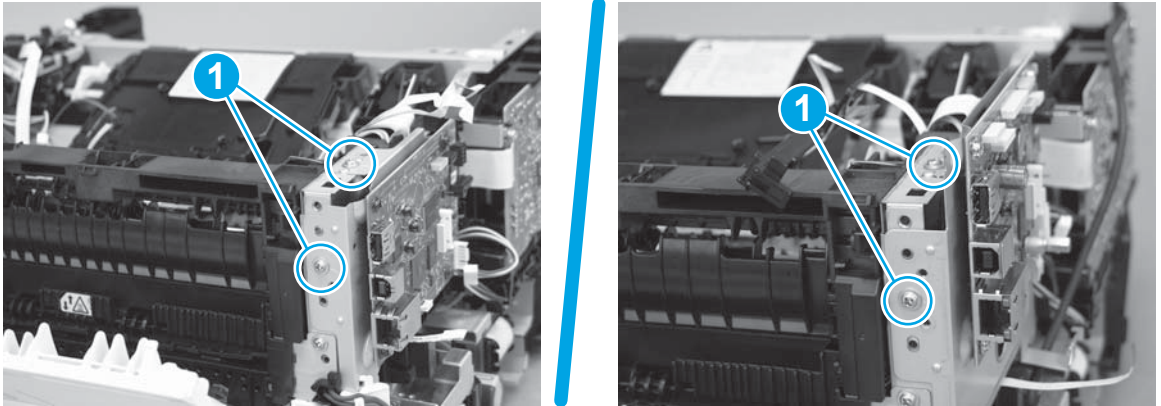

6. **M427/M426 only:** Install the guide (callout 1).

Figure 1-1916 Install the guide

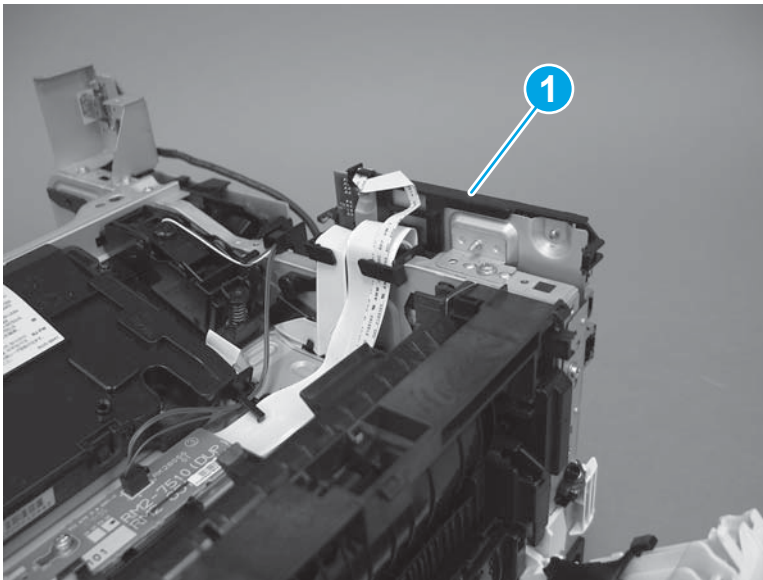

Step 16: Install the fan (FM1)

1. Position the fan in the holder. Make sure that the two tabs (callout 1) snap into place on the fan.

CAUTION: The fan must be correctly installed so that air is drawn into the printer. Make sure that the two arrows embossed on the right-side of the fan body—which indicate air flow direction—face upward and into the printer.

Figure 1-1917 Install the fan

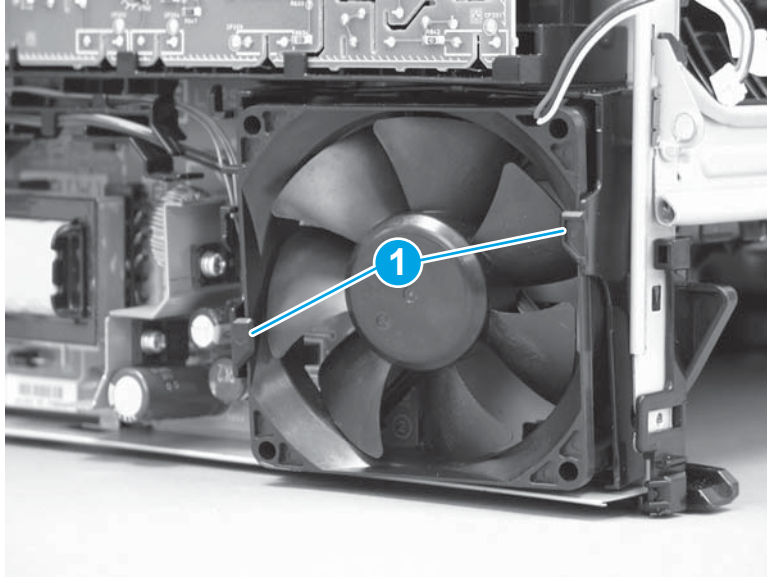

2. Install the wire harness on the retainer (callout 2), and then connect one connector (callout 2).

Figure 1-1918 Connect one connector

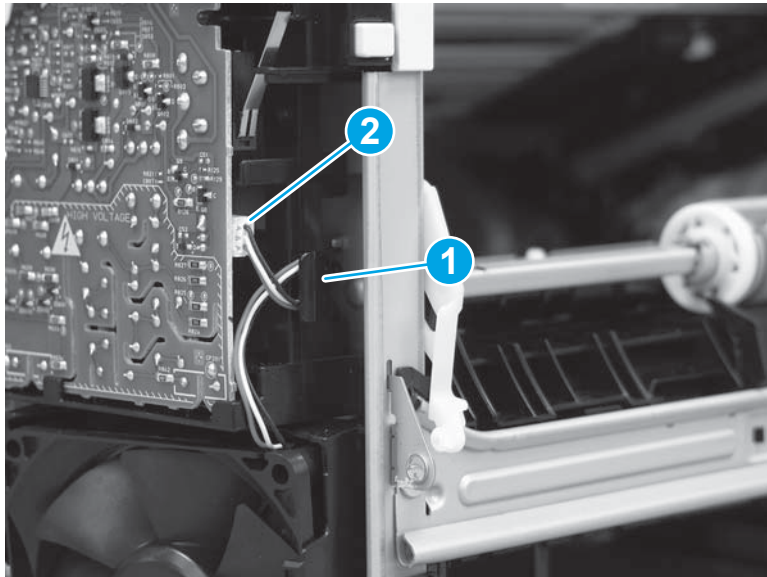

Step 17: Install the paper delivery tray (output bin)

 **NOTE:** This procedure shows the M403/M402 model, however, the paper delivery tray (output bin) removal is similar for the M427/M426 printer.

- ▲ Position the remove the paper delivery tray (output bin; callout 1) on the printer, engage two tabs (callout 2), and then engage two bosses (callout 3).

Figure 1-1919 Engage two tabs

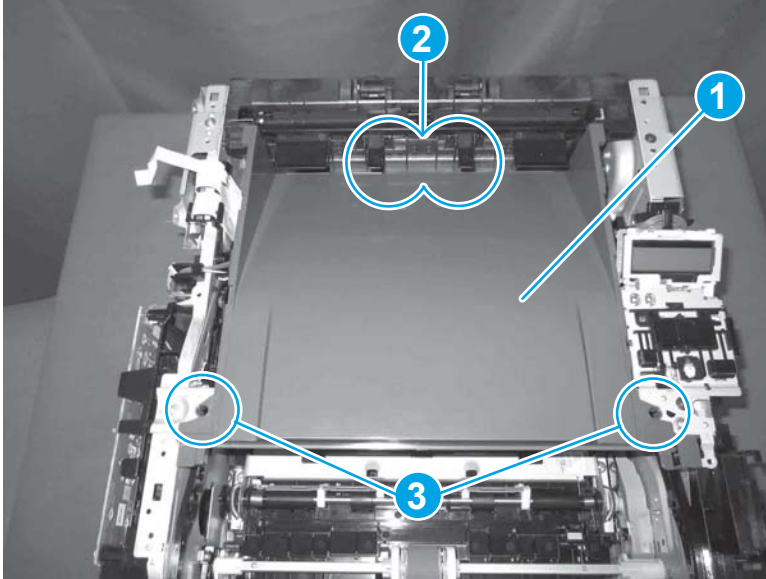

Step 18: Install the top cover (M403/M402)

 **NOTE:** The step is for the M403/M402 printer. For the M427/M426, skip this step and go to [Step 19: Install the top cover \(M427/M426\) on page 1014](#).

1. Position the rear edge of the cover on the printer.

Figure 1-1920 Install the cover

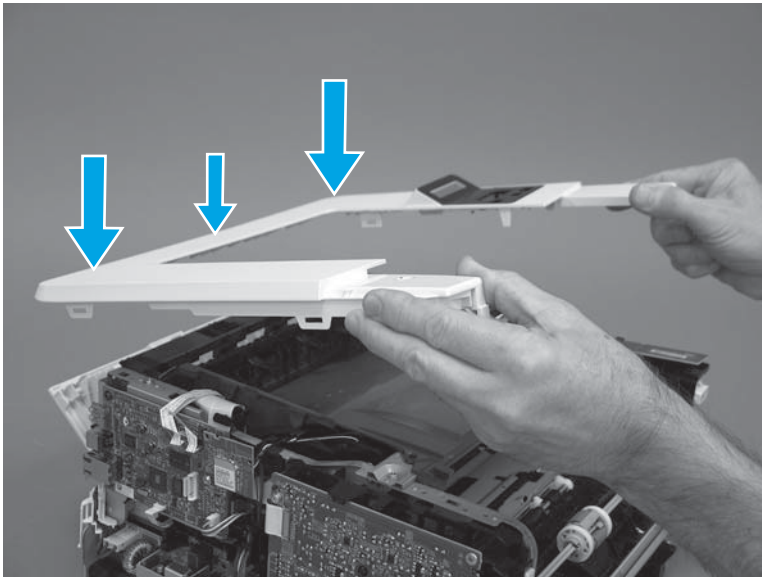

- Engage four bosses (callout 1), rotate the front of the cover down (callout 2) and onto from the printer, and then engage four tabs (callout 3).

Figure 1-1921 Engage four bosses and tabs

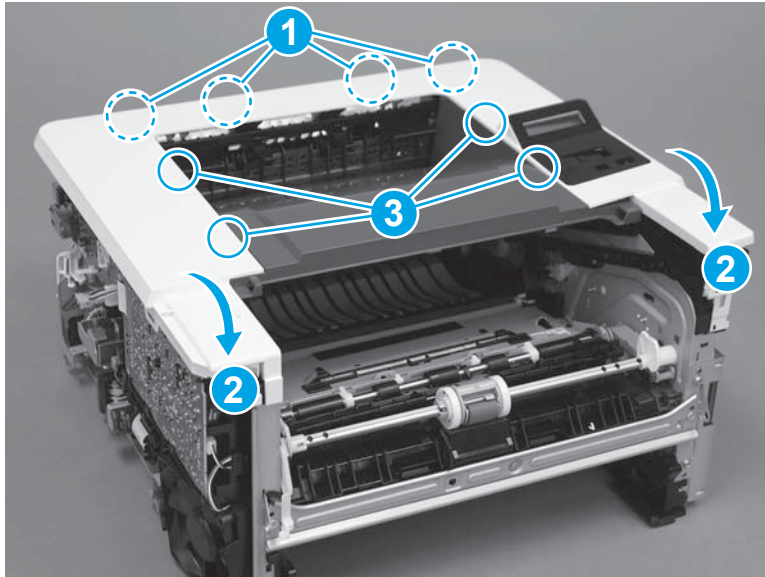

- At the right side of the printer, engage the one boss and one tab (callout 1).

Figure 1-1922 Engage one boss and one tab

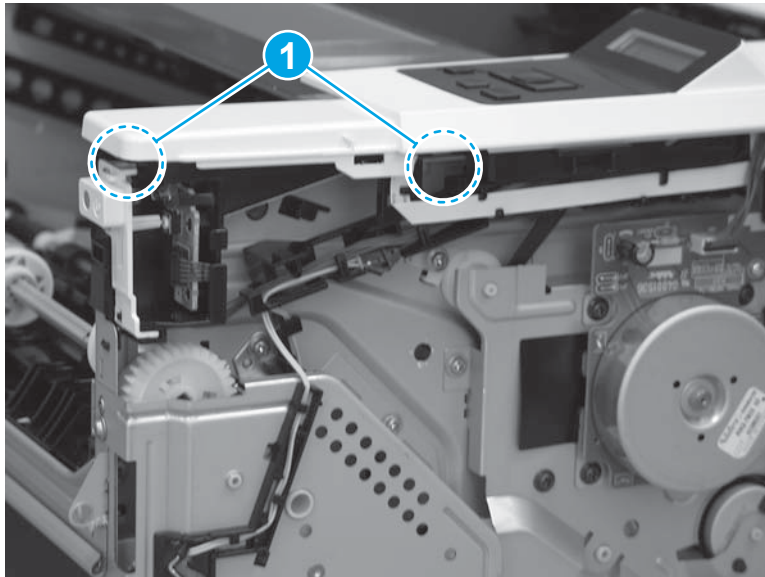

4. Install one screw (callout 1).

Figure 1-1923 Install one screw

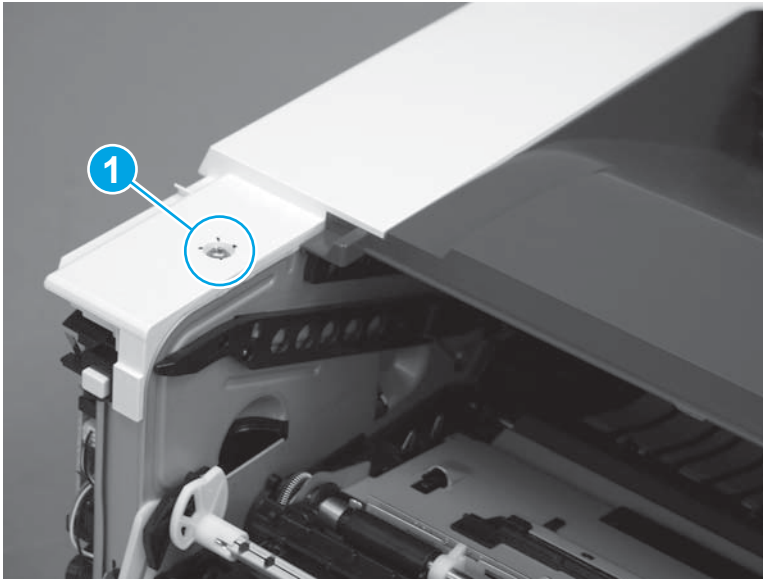

Step 19: Install the top cover (M427/M426)

 **NOTE:** The step is for the M427/M426 printer. For the M403/M402, skip this step and go to [Step 23: Install the right cover on page 1025](#).

1. Position the rear edge of the top cover on the printer.

Figure 1-1924 Install the cover

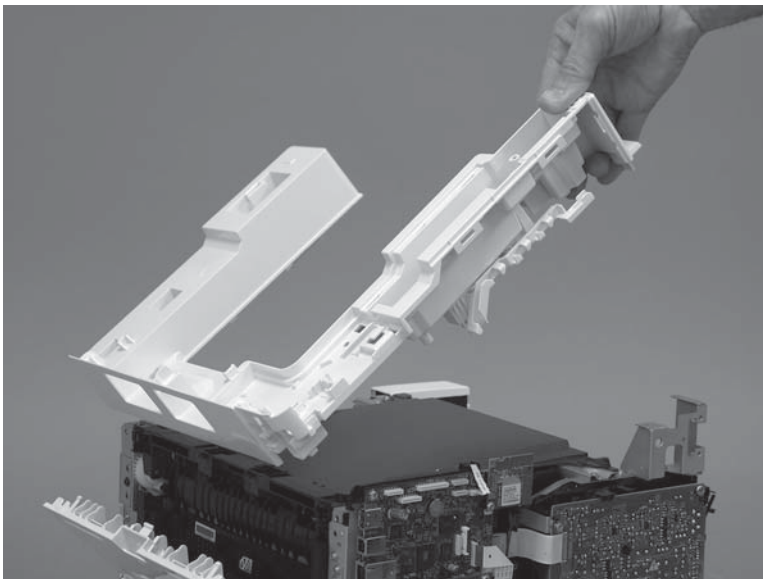

2. Engage four bosses (callout 1).

Figure 1-1925 Engage four bosses

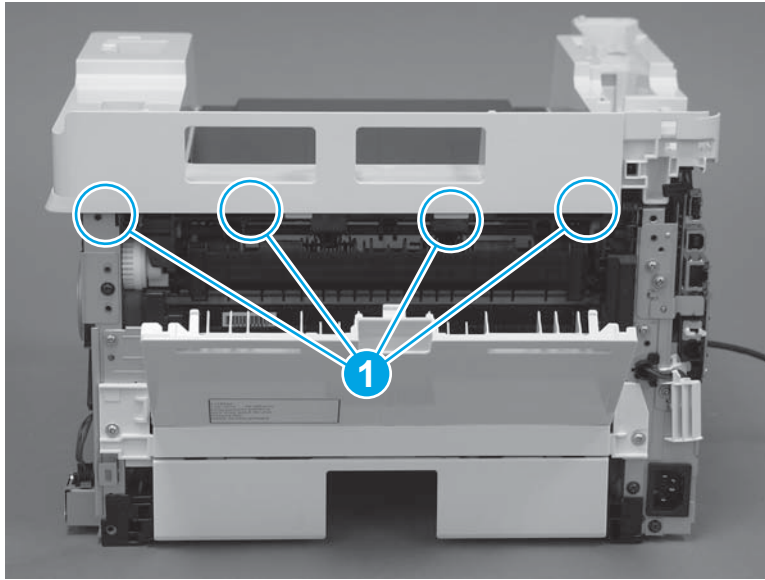

3. Rotate the front edge of the cover down.

Figure 1-1926 Rotate the front edge of the cover down

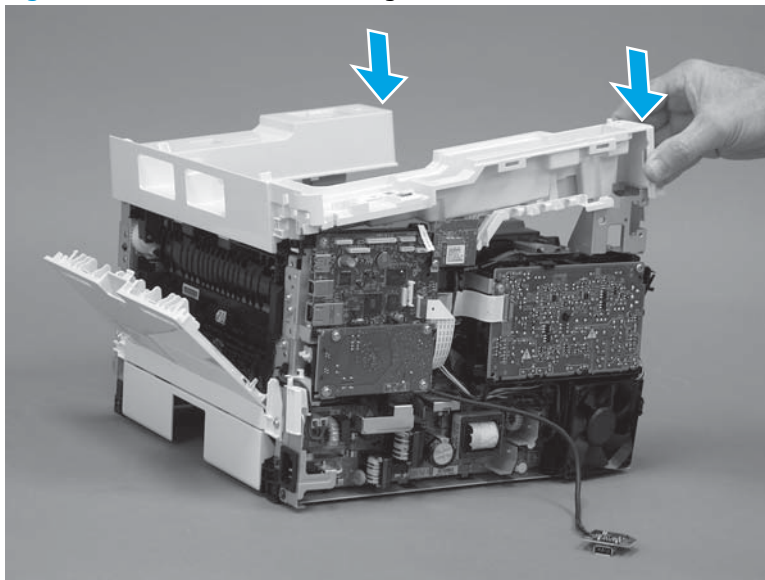

4. Install the USB cable (callout 1) in the guide.

Figure 1-1927 Install the USB PCA

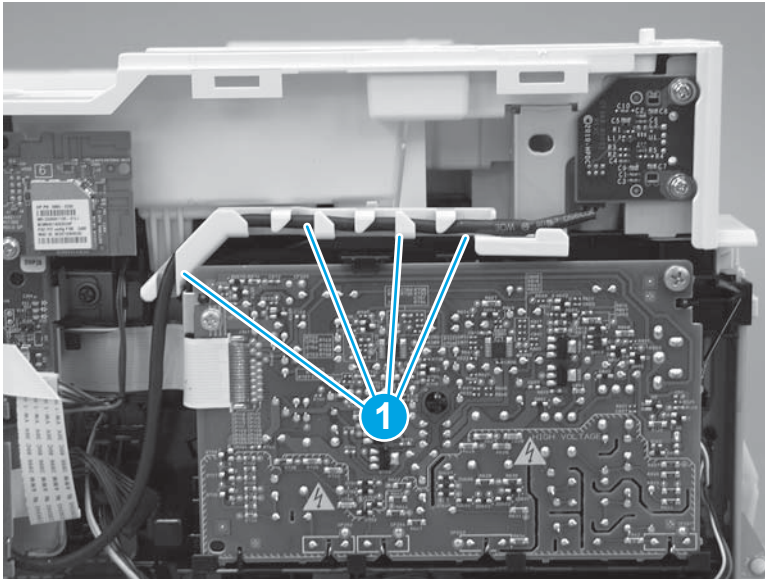

5. Install five screws (callout 1).

Figure 1-1928 Install five screws

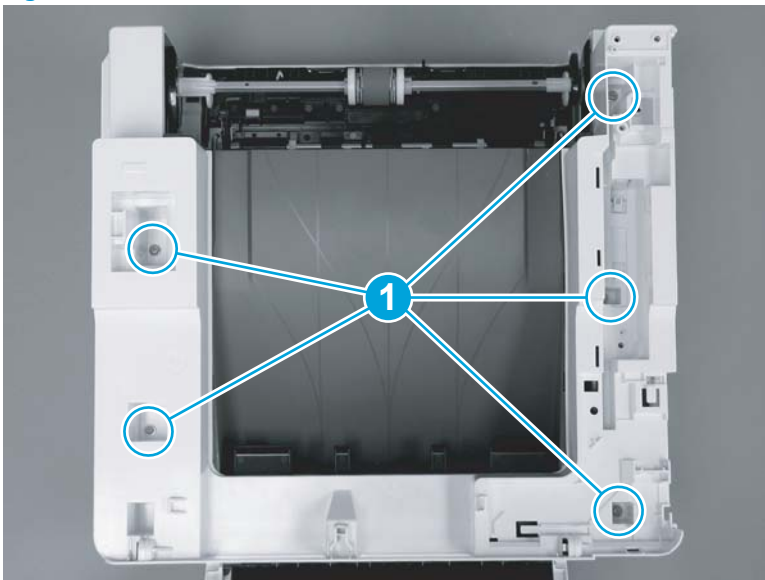

Step 20: Install the control panel (M427/M246)

 **NOTE:** The step is for the M427/M426 printer. For the M403/M402, skip this step and go to [Step 23: Install the right cover on page 1025](#).

1. Slide the control-panel FFC cover into the slot in the top cover (next to the document feeder support arm) to install it.

Figure 1-1929 Install the control-panel FFC cover

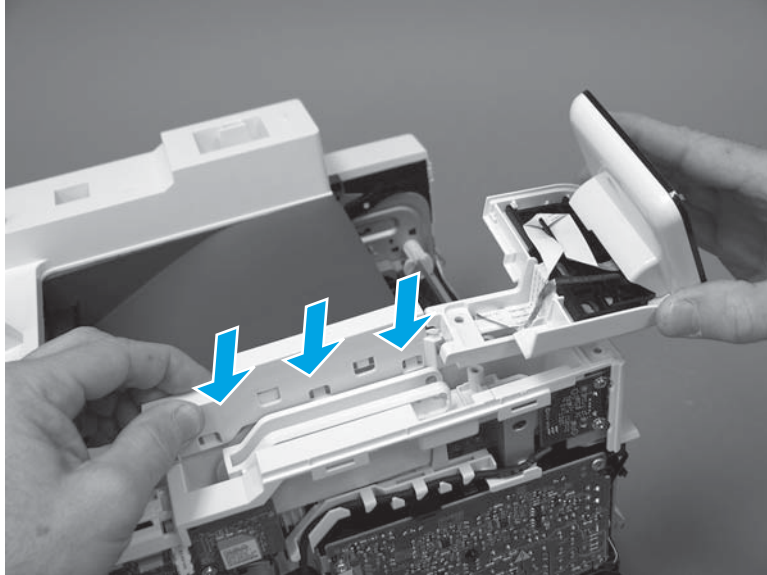

2. Install the control-panel assembly on the top cover.

Figure 1-1930 Install the control-panel assembly

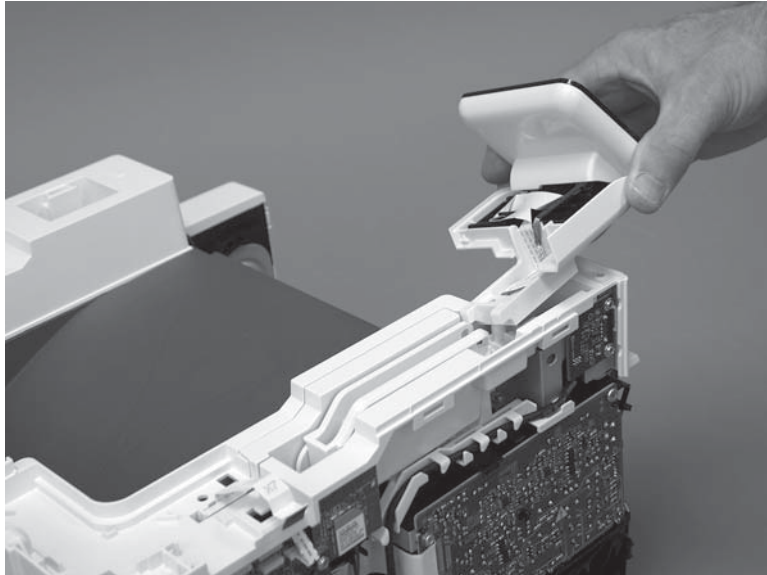

3. Move the FFC out of the way, and then install two screws (callout 1).

Figure 1-1931 Install two screws

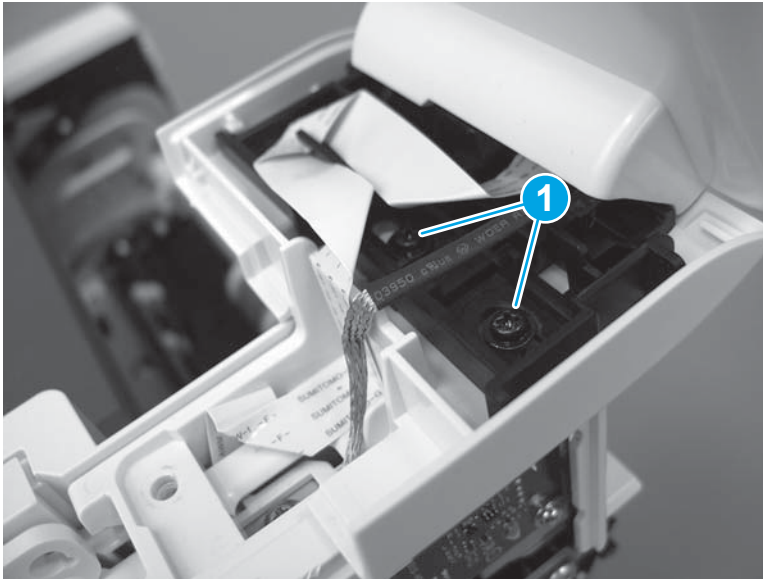

4. Install one grounding screw (callout 1), and then make sure that the ground cable (callout 2) is properly routed.

Figure 1-1932 Remove one screw

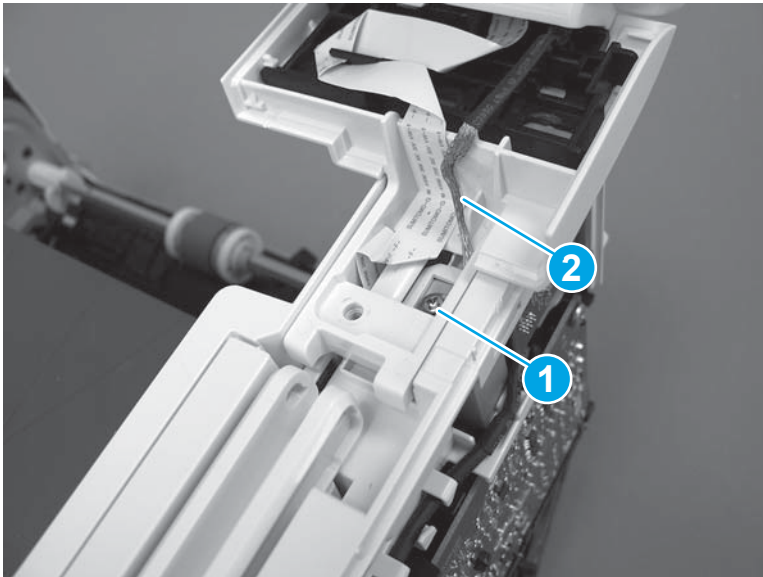

5. Install the control-panel cable cover.

Figure 1-1933 Install the cover

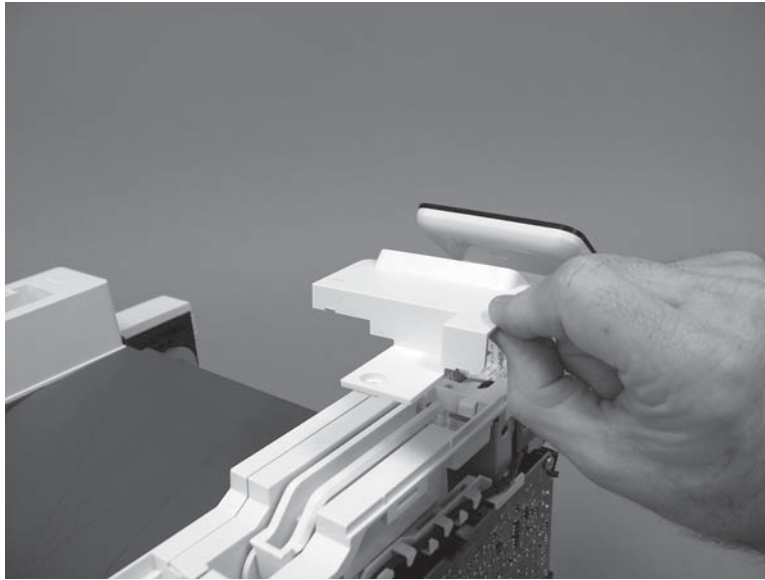

6. Make sure that the two tabs (callout 1) on the cover snap into place.

Figure 1-1934 Engage two tabs

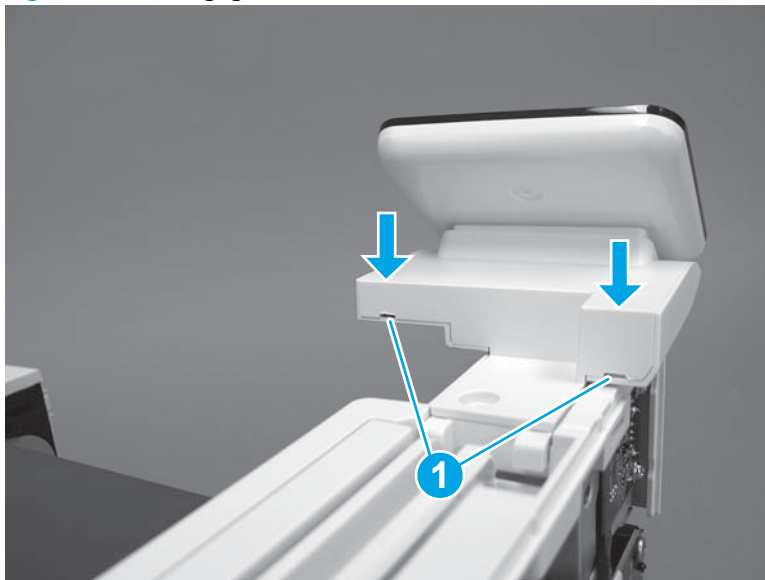

7. Install one screw (callout 1).

Figure 1-1935 Install one screw

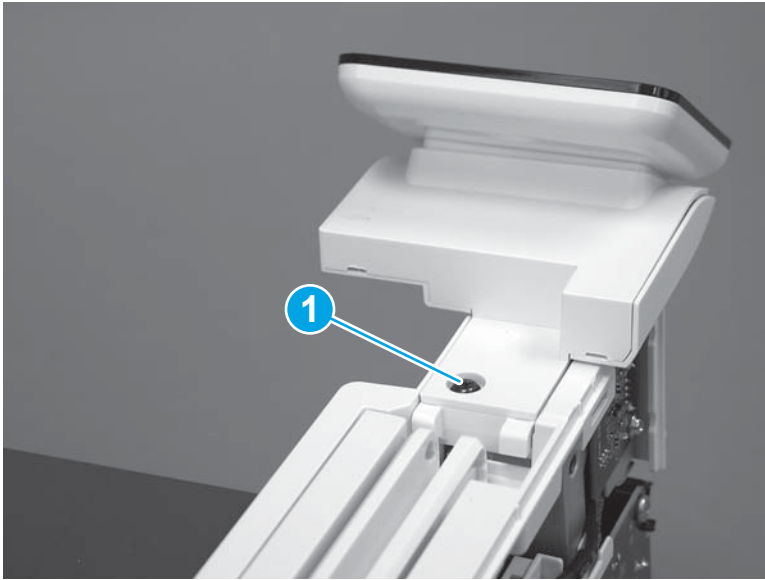

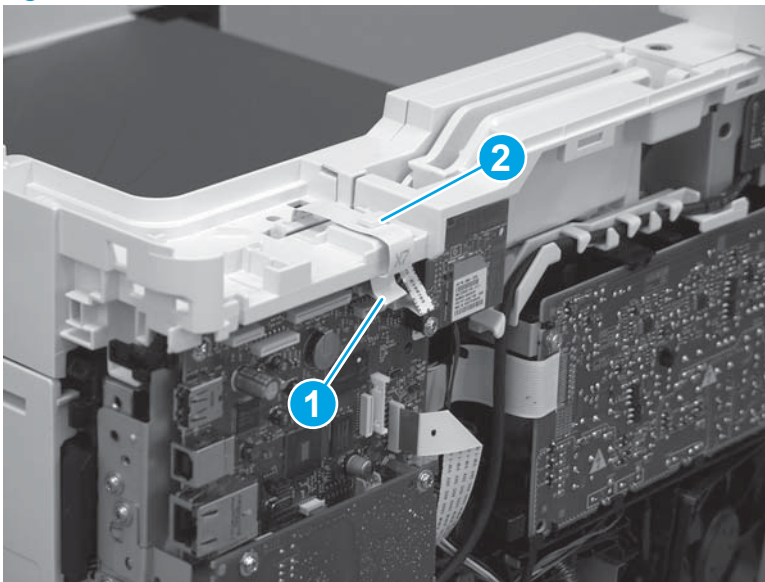

8. Install the FFC in the retainer (callout 1), and then connect one FFC (callout 1; J114).

Figure 1-1936 Connect one connector



Step 21: Install the integrated scanner assembly (M427/M246)

 **NOTE:** The step is for the M427/M426 printer. For the M403/M402, skip this step and go to [Step 23: Install the right cover on page 1025](#).

 **NOTE:** M427/M426 models only. The integrated scanner assembly (ISA) includes the sub-scanner assembly (SSA) and the automatic document feeder (ADF).

1. Position the ISA on the printer.

Figure 1-1937 Position the ISA on the printer

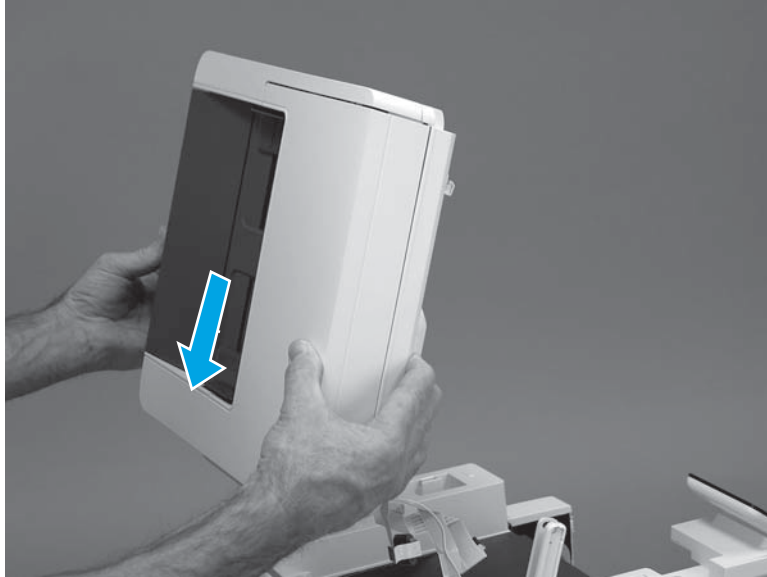

2. Engage the hinge pins on the ISA with the holders in the top cover (callouts 1/2), and then slide the ISA as shown to engage them

Figure 1-1938 Engage the hinge pins with the holders

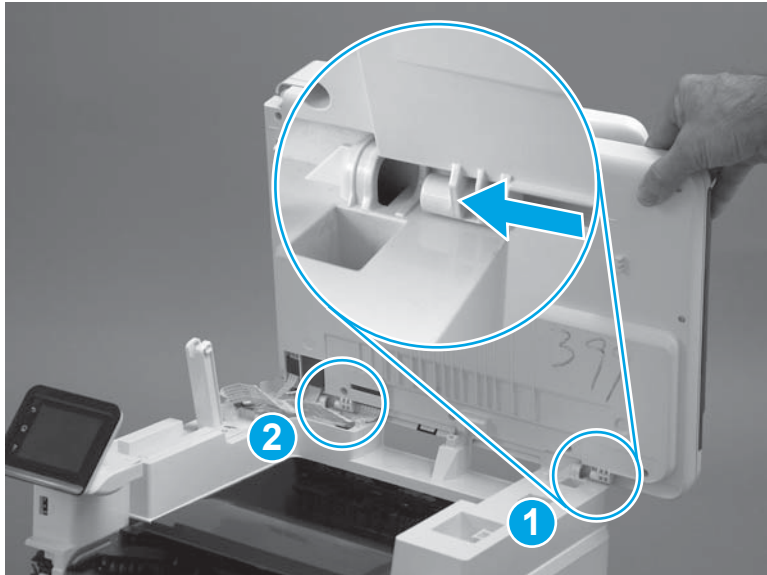

3. Rotate the ISA towards the front of the printer until it rests on the ISA lift assembly (callout 1).

Figure 1-1939 Rotate the ISA towards the front of the printer

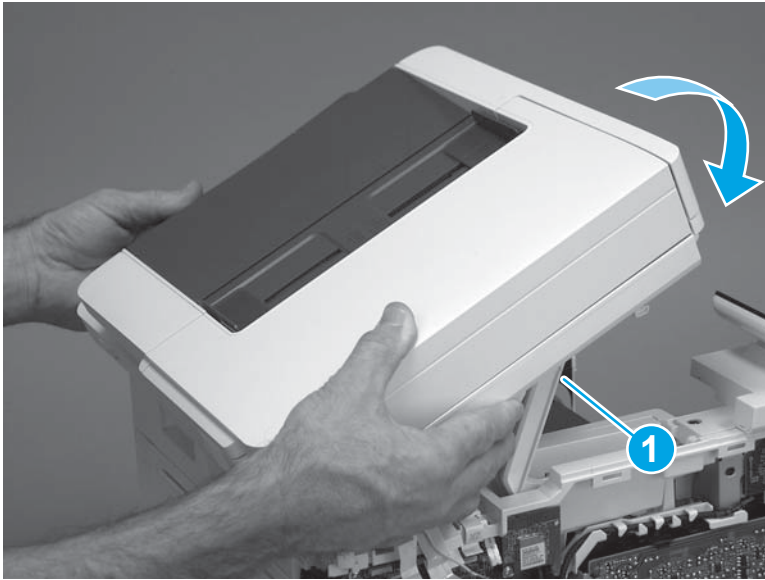

4. Pass the ground wire through the opening in the top cover.

Figure 1-1940 Pass the wire through the opening

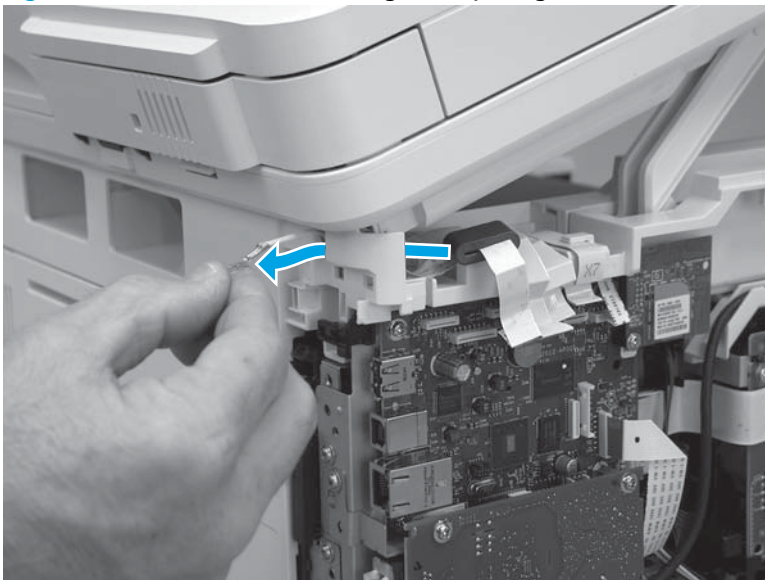

5. Install one screw (callout 1).

Figure 1-1941 Install one screw

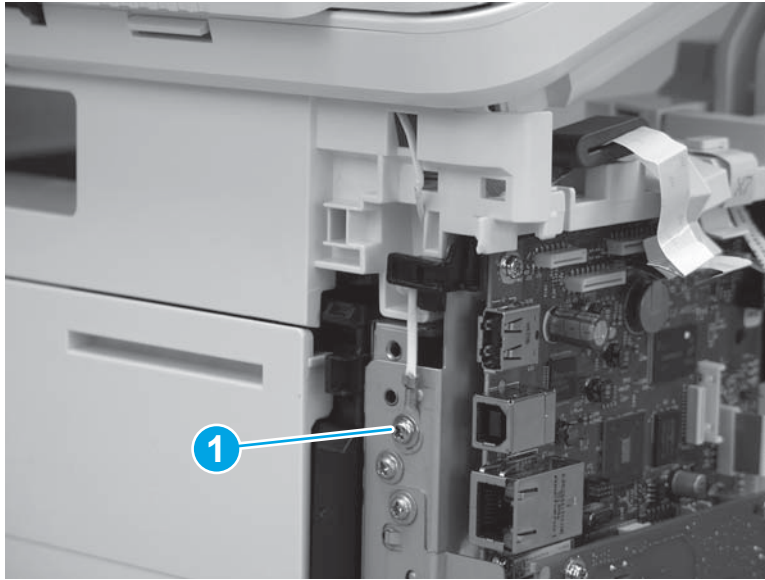

6. Install the ISA lift assembly slider pin.

 **Reinstallation tip:** Align the keyed portion of the locking pin with the slot and hole in the support arm.

Figure 1-1942 Install the slider pin



7. Rotate the slider pin (callout 1) towards the rear of the printer until the tab (callout 2) snap into place.

Figure 1-1943 Secure the slider pin

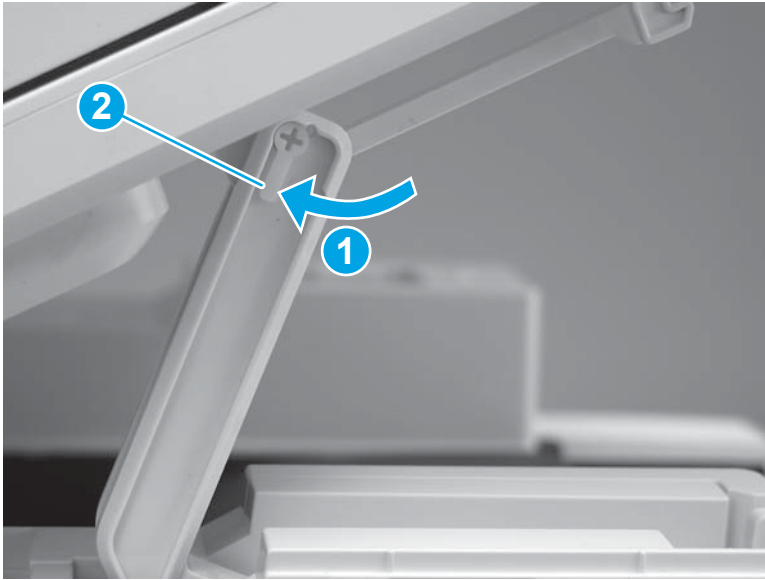

8. Install the ferrite (callout 1) in the holder, and then connect three FFCs (callout 2).

Figure 1-1944 Connect three FFCs

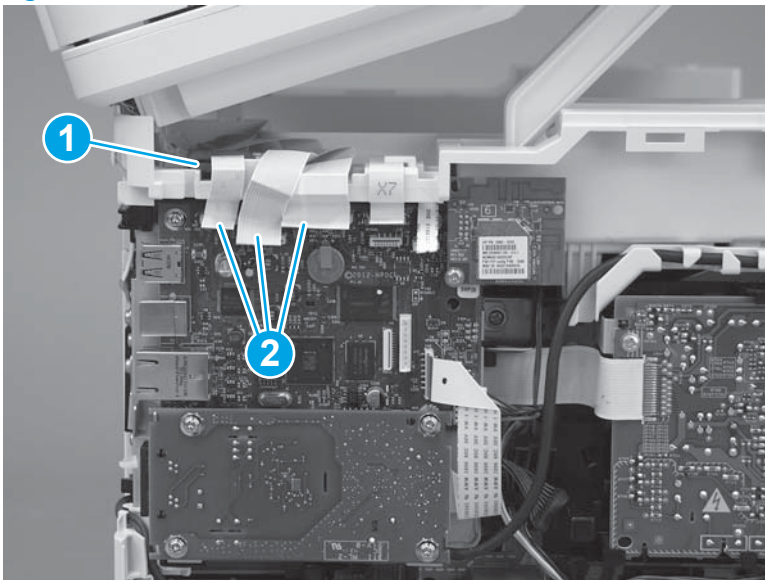

9. Position the rear edge of the ISA flat-flexible cable (FFC) cover on the printer (callout 1) , and then rotate it down (callout 2) until it snaps into place.

Figure 1-1945 Install the ISA FFC cover

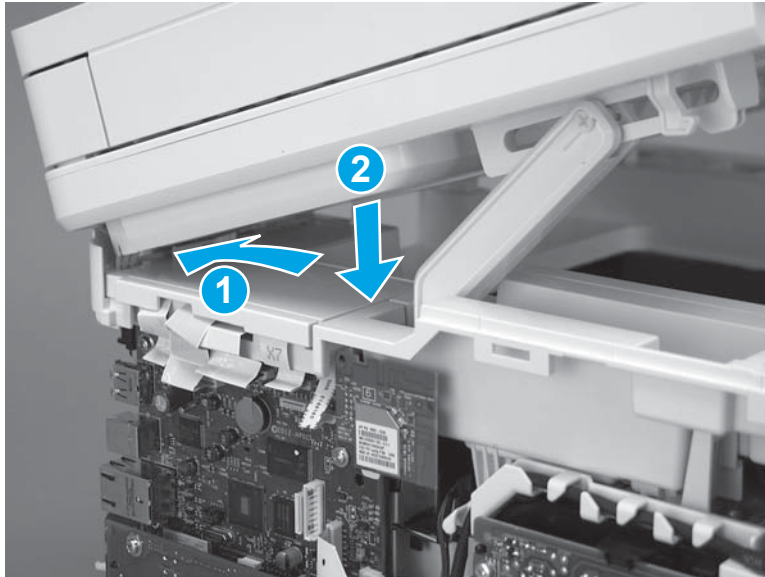

10. Lower the ISA.

Figure 1-1946 Lower the ISA

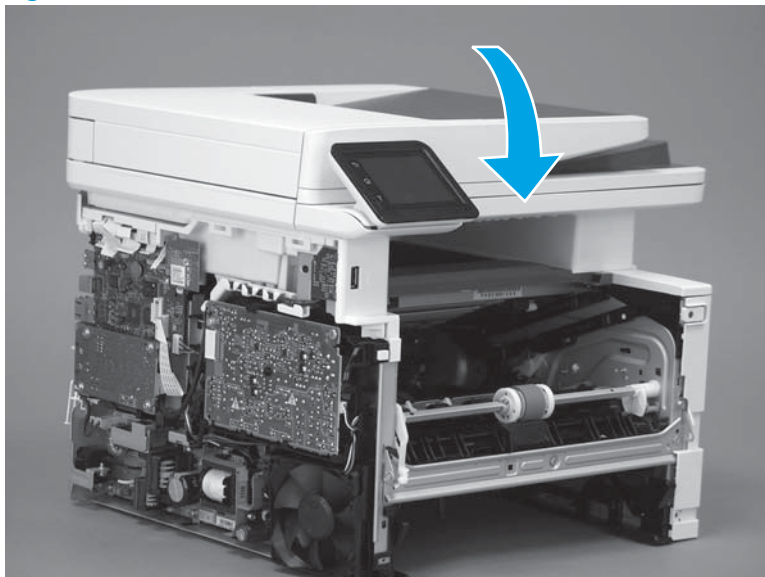

Step 23: Install the right cover

1. Position the cover (callout 1) on the printer, and then engage two bosses (callout 2).

Figure 1-1947 Install the cover

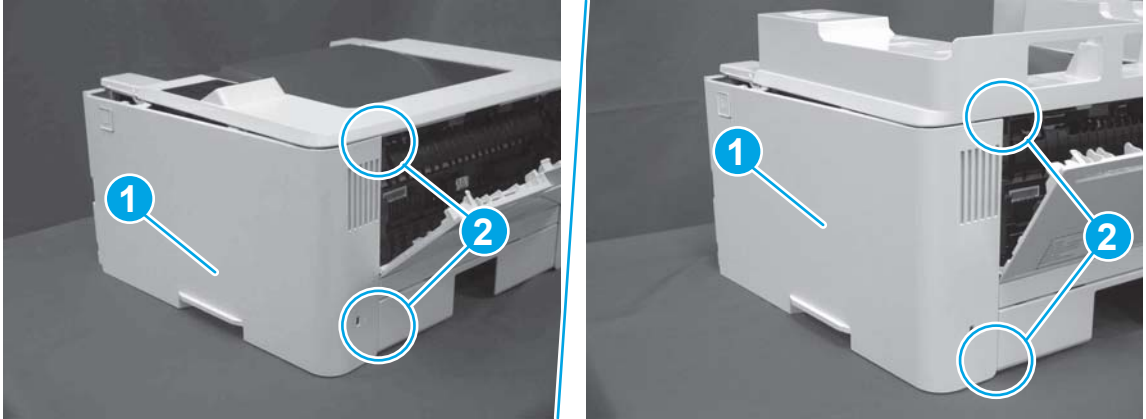

2. Rotate the front of the cover onto the printer (callout 1), engage three (callout 2) tabs, and then engage two bosses (callout 3).

Figure 1-1948 Engage two bosses and one tab

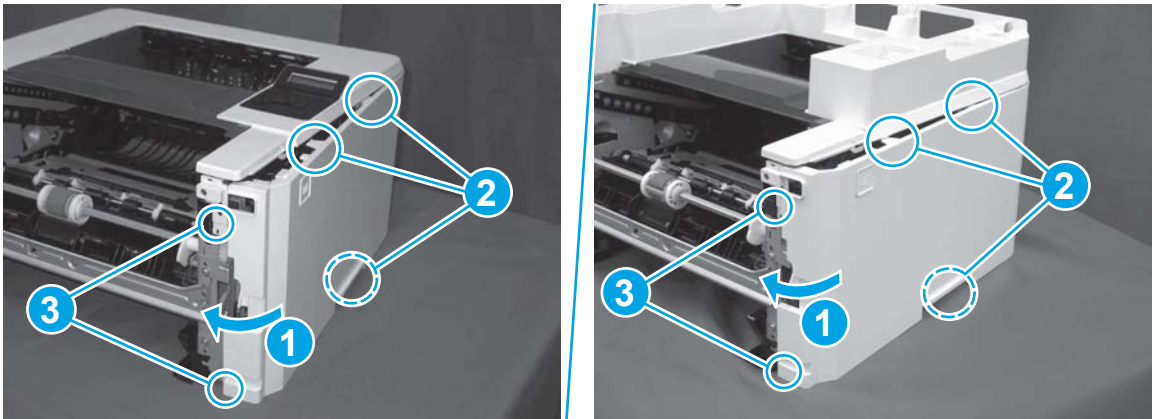

3. Make sure that the power switch (callout 1) and cartridge door assembly button (callout 2) correctly function.

 **NOTE:** Remove, and then reinstall the cover if the switch or button does not correctly function.

Figure 1-1949 Check the power switch and cartridge door assembly button



4. Install one screw (callout 1).

Figure 1-1950 Install one screw

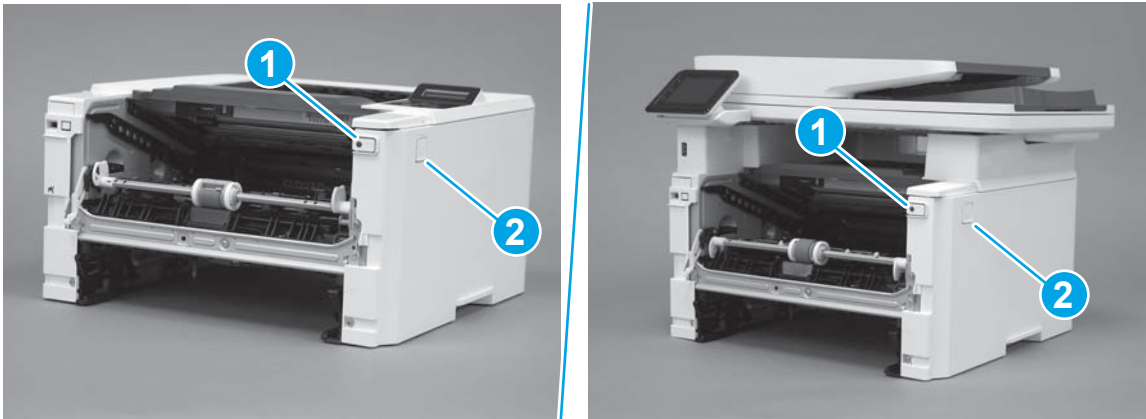

Step 24: Install the left cover

1. At the front of the printer, do one of the following:
 - **M403/M402:** Position the cover on the printer (callout 1), and then engage two bosses (callout 2).
 - **M427/M426:** Position the cover on the printer (callout 3), engage one tab (callout 4), and then engage two bosses (callout 4).

Figure 1-1951 Install the cover

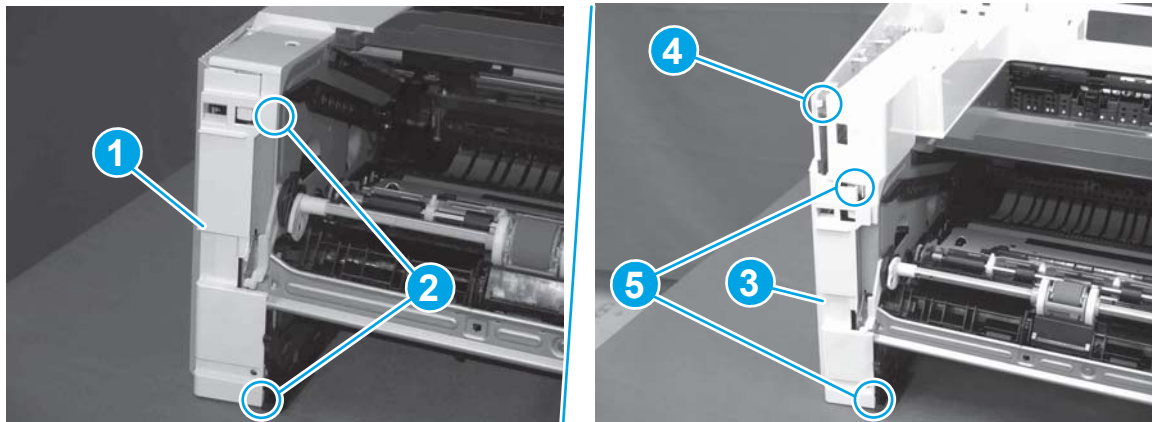

- Carefully rotate the rear of the cover onto the printer (callout 1), engage three tabs (callout 2), and then engage two bosses (callout 3).

Figure 1-1952 Engage three tabs and two bosses

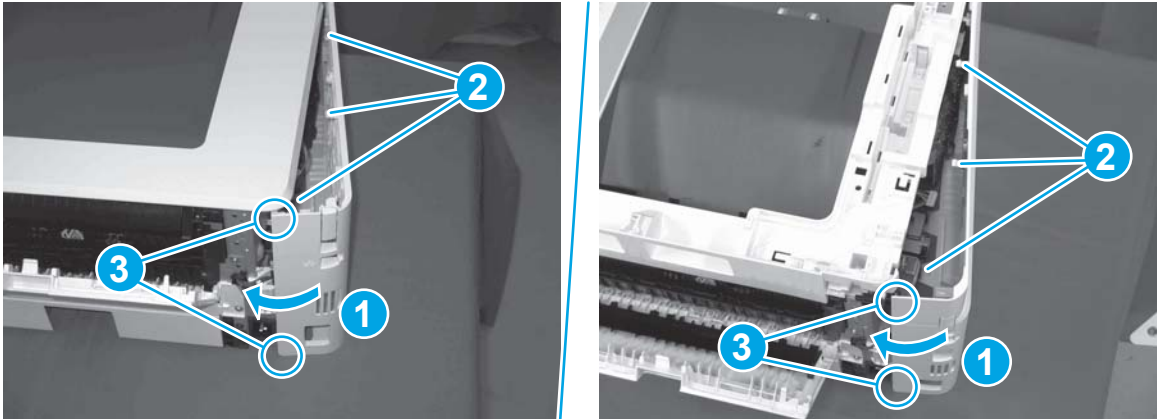

- Install one screw (callout 1).

Figure 1-1953 Install one screw

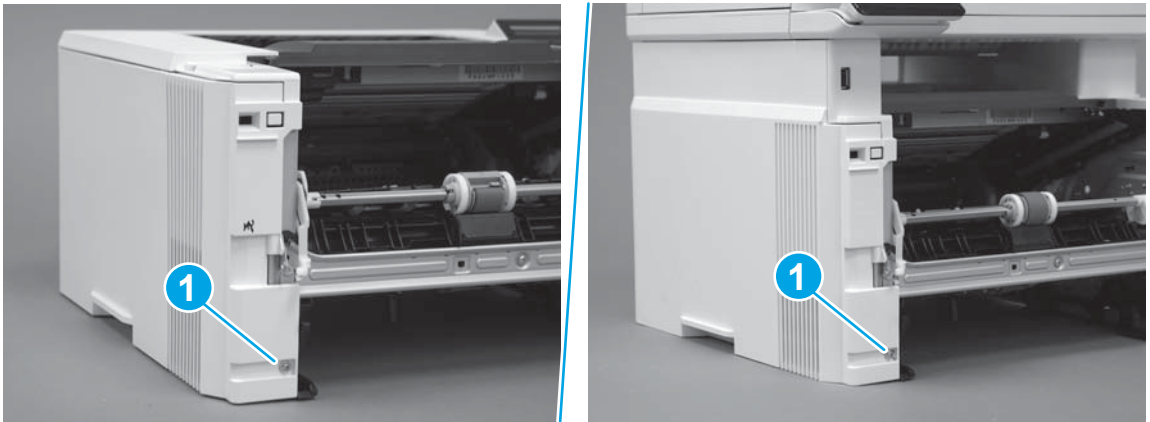

Step 25: Install the cartridge door assembly

 **Reinstallation tip:** After a replacement door is installed, make sure to install the nameplate (supplied in the kit) corresponding to the printer name on the door.

- Position the door close to the printer, and then engage the keyed pin on the left-side retainer arm with the hole in the door.

Figure 1-1954 Engage the left-side retainer arm

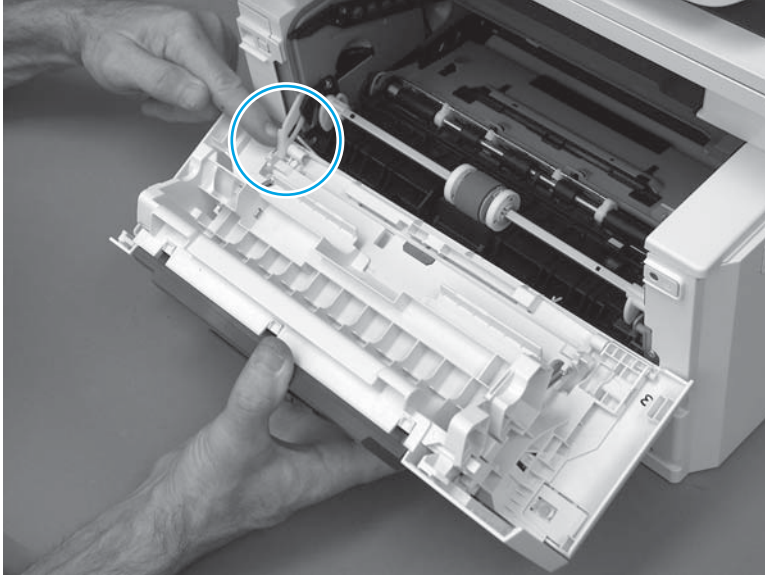

2. Engage the right-side door hinge pin with the hole in the chassis (callout 1).

Figure 1-1955 Install the door

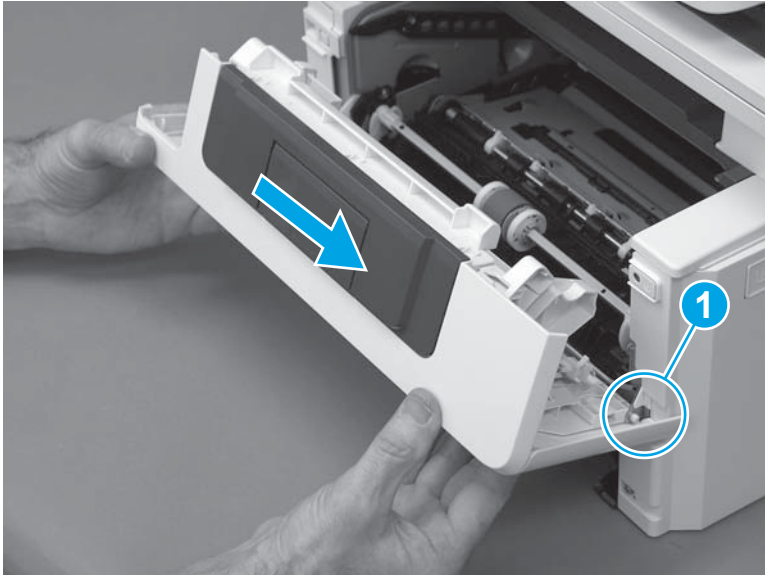

3. Install the link (callout 1).

 **IMPORTANT:** Make sure that the link snaps into place on the arm (callout 2). The link actuates the fuser pressure-release mechanism.

Figure 1-1956 Install the pressure-release link

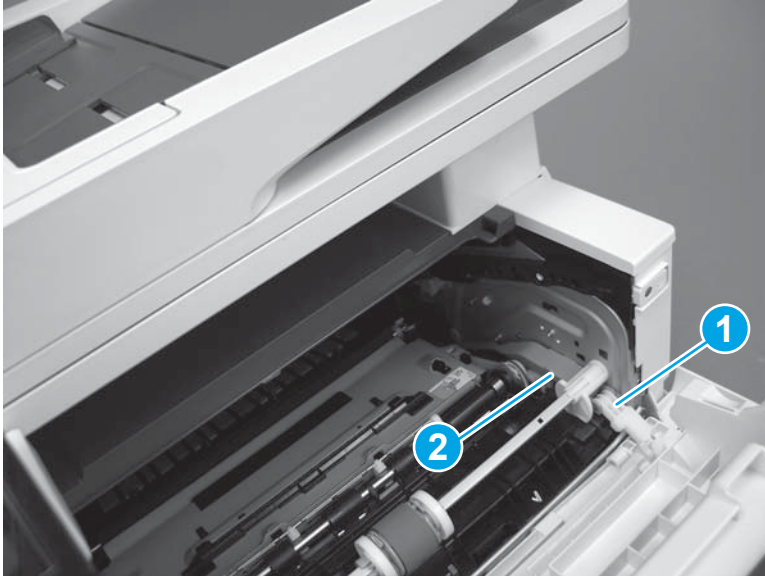

4. Slide the guide into the printer (callout 1), and then make sure that the tab (callout 2) snaps into place to secure the guide to the chassis.

Figure 1-1957 Install the guide

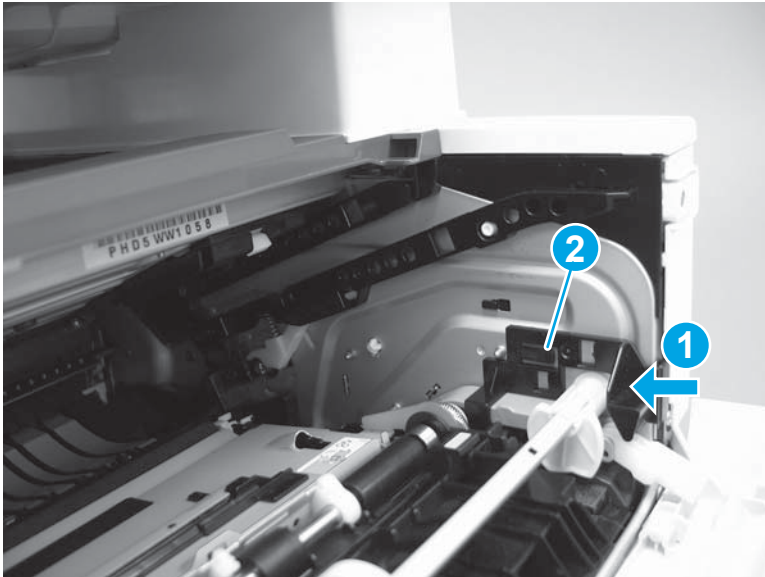

5. Position the shaft on the door, and then align the left-side hinge on the door with the hole in the chassis (callout 1).

Figure 1-1958 Align the hinge

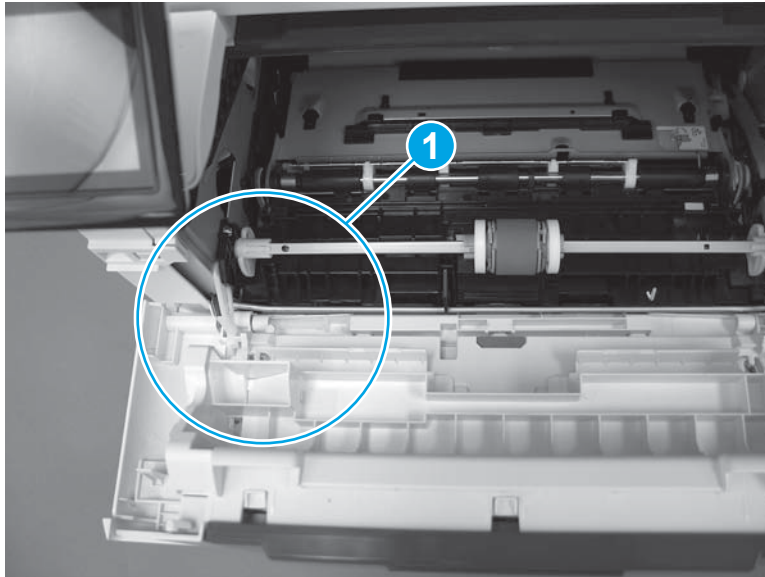

6. Push the shaft towards the left side of the printer to install it (callout 1).

 **Reinstallation tip:** Make sure that the support shaft is fully installed and correctly orientated (callout 2) so that it will not interfere with the door opening and closing.

Figure 1-1959 Install the support shaft



Step 26: Install Tray 2

- ▲ Slide the tray straight into the printer to install it.

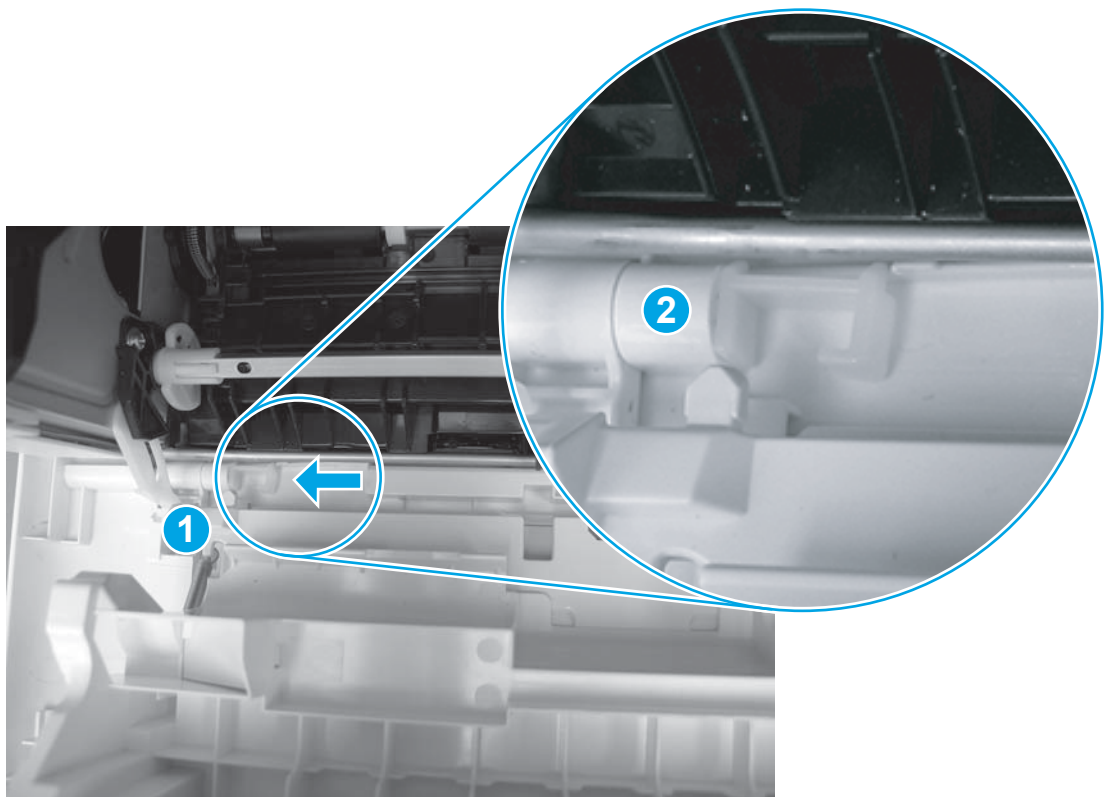
Figure 1-1960 Install the tray



Removal and replacement: NFC cover (M427/M426)



NOTE: M427/M426 models only.

- [Introduction](#)
- [Step 1: Remove Tray 2](#)
- [Step 2: Remove the cartridge door assembly](#)
- [Step 3: Remove the left cover](#)
- [Step 4: Remove the right cover](#)
- [Step 6: Remove the integrated scanner assembly \(M427/M246\)](#)
- [Step 5: Remove the control panel \(M427/M426\)](#)
- [Step 7: Remove the top cover \(M427/M426\)](#)
- [Step 8: Remove the NFC cover \(M427/M426\)](#)
- [Step 9: Unpack the replacement assembly](#)
- [Step 10: Install the NFC cover \(M427/M426\)](#)
- [Step 11: Install the top cover \(M427/M426\)](#)
- [Step 12: install the control panel \(M427/M426\)](#)
- [Step 12: Install the integrated scanner assembly \(M427/M246\)](#)
- [Step 13: Install the right cover](#)
- [Step 14: Install the left cover](#)
- [Step 15: Remove the cartridge door assembly](#)
- [Step 16: Install Tray 2](#)

Introduction

This document provides the procedures to remove and replace the near field communication (NFC) cover.

Before performing service

Turn the printer power off

- Disconnect the power cable.



WARNING! To avoid damage to the printer, turn the printer off, wait 30 seconds, and then remove the power cable before attempting to service the printer.

Use the table below to identify the correct part number for your printer. To order the part, go to www.hp.com/buy/parts.

NFC cover part number	
RC4-2961-000CN	NFC cover

Required tools

- #2 Phillips screwdriver with a magnetic tip.

After performing service

Turn the printer power on

- Connect the power cable.
- Use the power switch to turn the power on.

Post service test

Make sure that the printer initializes to a **Ready** state.

Use a NFC enabled device to print a job from the printer.

Step 1: Remove Tray 2

- ▲ Pull the tray straight out of the printer to remove it.

Figure 1-1961 Remove the tray



Step 2: Remove the cartridge door assembly

 **NOTE:** If the toner cartridge was not removed prior to servicing the printer, remove it now.

1. Release one tab (callout 1), and then slide shaft (callout 2) in the direction the arrow indicates and remove it.

 **TIP:** It might be easier to release the support shaft by using a small flat-blade screwdriver.

Figure 1-1962 Release the support shaft

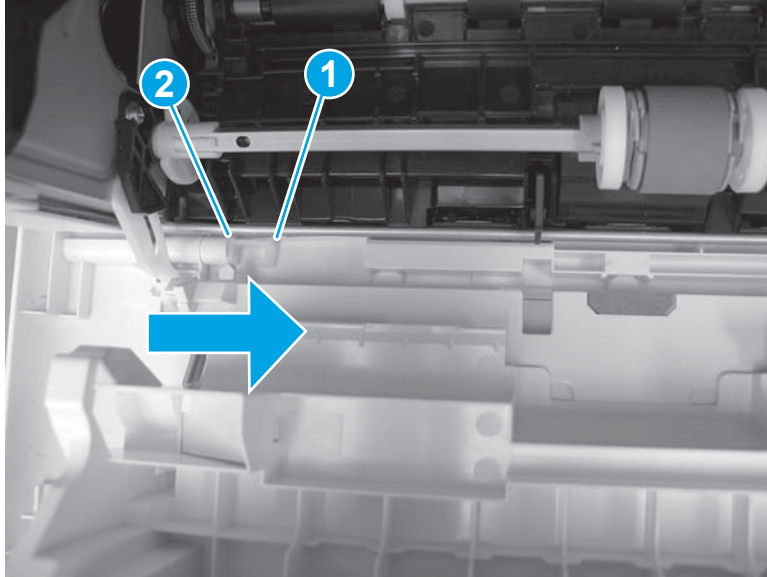

2. Release one tab (callout 1), and then slide the guide (callout 2) in the direction the arrow indicates and remove it.

Figure 1-1963 Remove the guide

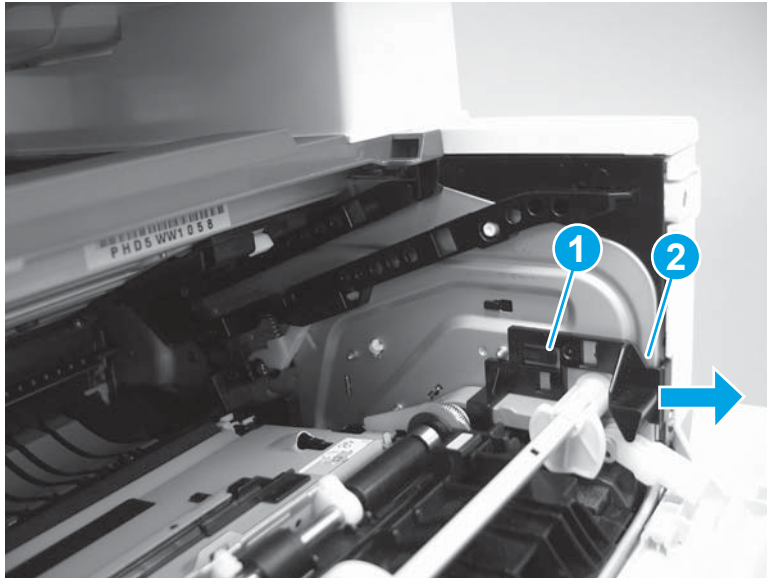

3. Remove the link arm (callout 1).

Figure 1-1964 Remove the link arm

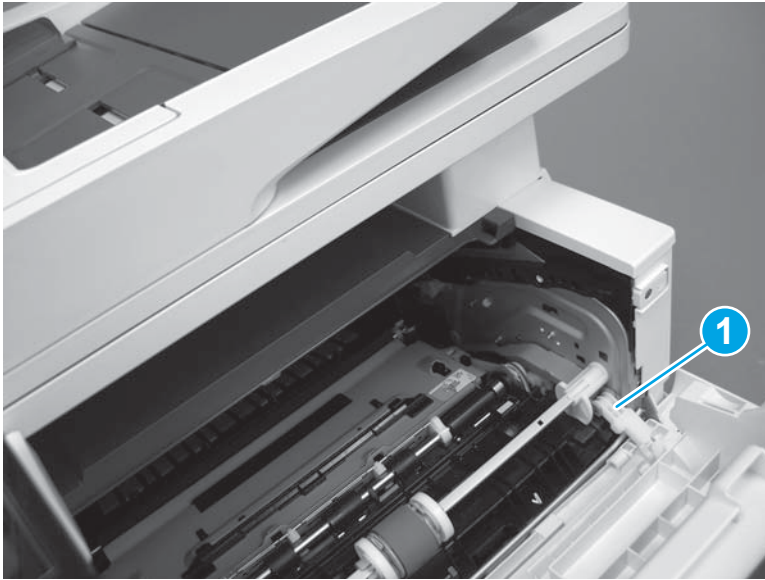

4. Slide the cartridge door assembly (callout 1) in the direction the arrow indicates and remove it.

Figure 1-1965 Remove the door

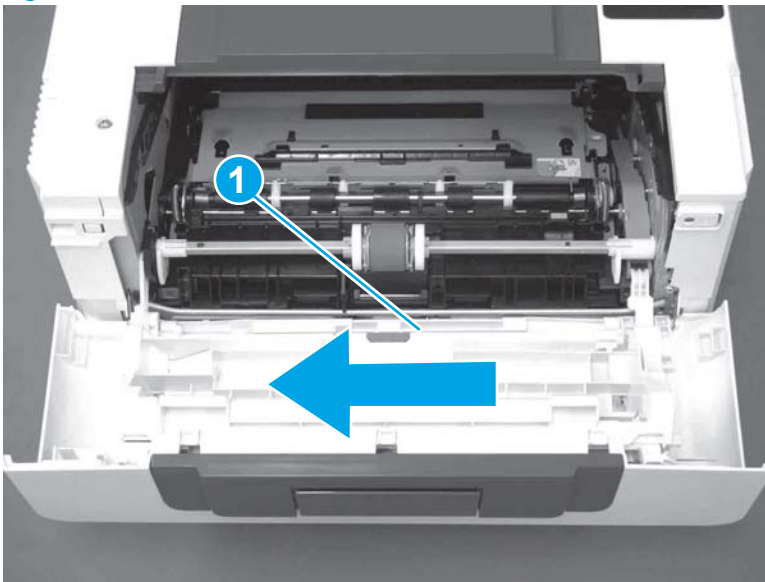

5. Remove the link (callout 1) from the cartridge door assembly (callout 2).

Figure 1-1966 Release the left-side retainer arm

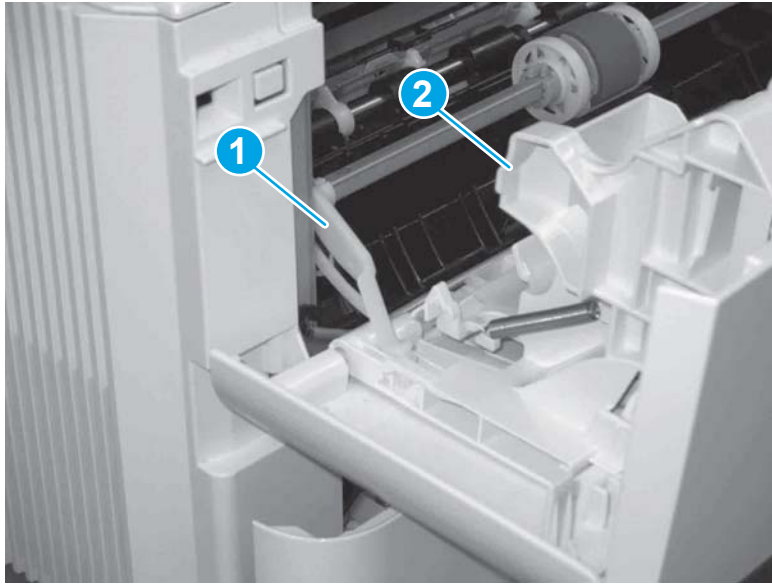

Step 3: Remove the left cover

1. Remove one screw (callout 1).

Figure 1-1967 Remove one screw

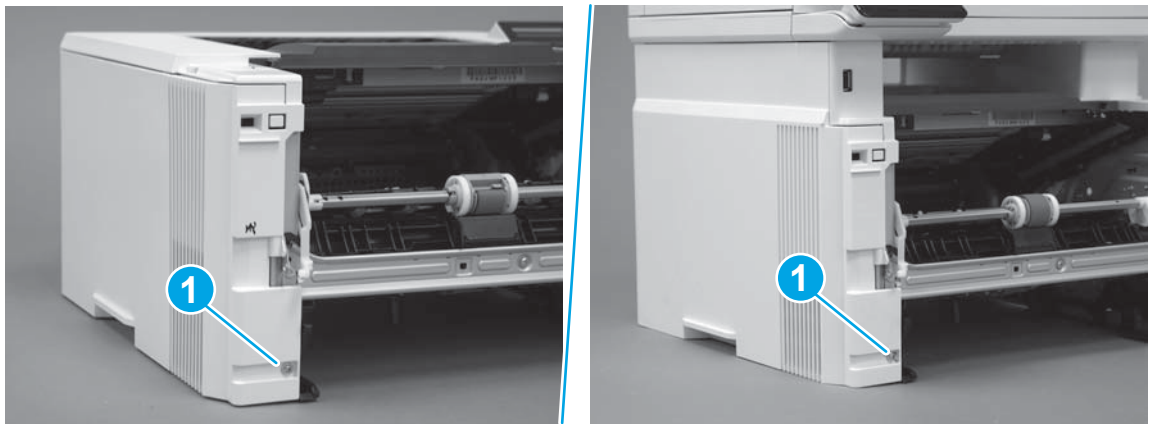

2. Open the rear door, release two bosses (callout 1), and then release three tabs (callout 2).

Figure 1-1968 Release two bosses and three tabs

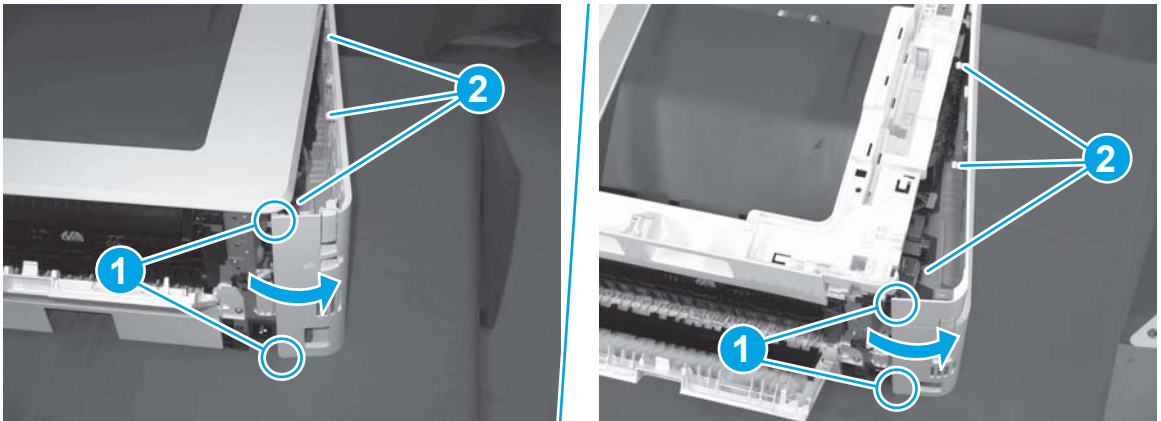

3. At the front of the printer, do one of the following:
 - **M403/M402:** Release two bosses (callout 1), and then remove the cover (callout 2).
 - **M427/M426:** Release one tab (callout 3), two bosses (callout 4), and then remove the cover (callout 5).

CAUTION: Be careful when releasing the upper bosses on the M427/M426 cover. One portion of the cover (callout 6) is fragile and is easily broken.

Figure 1-1969 Remove the cover

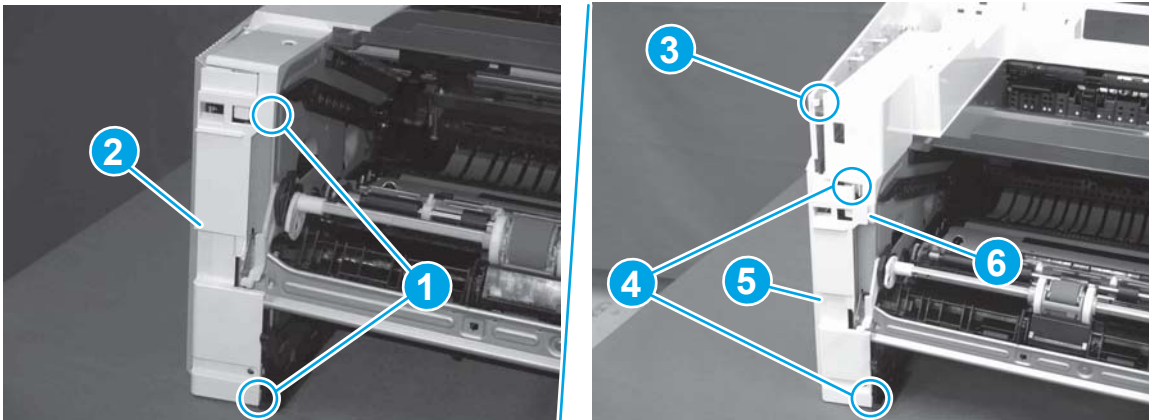

Step 4: Remove the right cover

1. Remove one screw (callout 1).

Figure 1-1970 Remove one screw

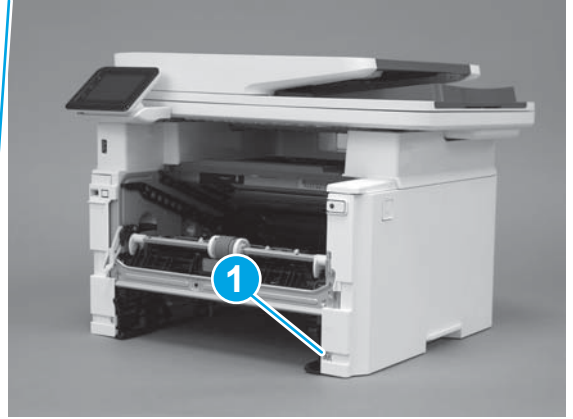
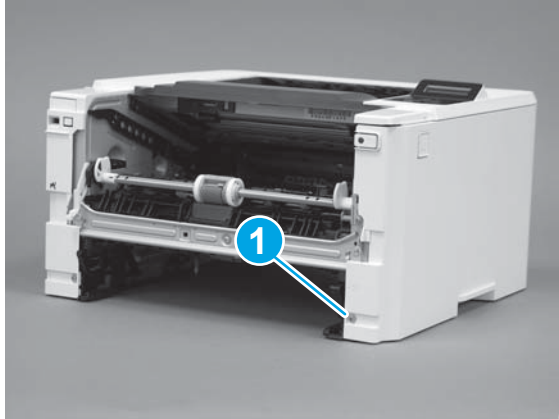

2. At the front of the printer, release two bosses (callout 1), and then release three tabs (callout 2).

Figure 1-1971 Release two bosses and three tabs

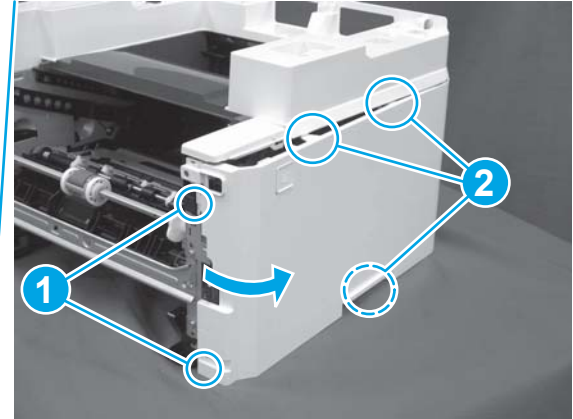
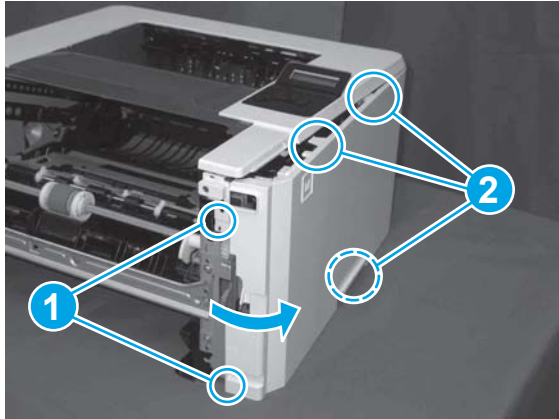

3. Open the rear door, release two bosses (callout 1), and then remove the cover (callout 2).

Figure 1-1972 Remove the cover

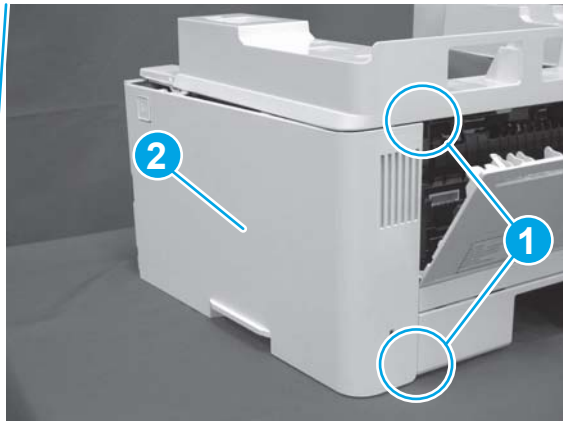
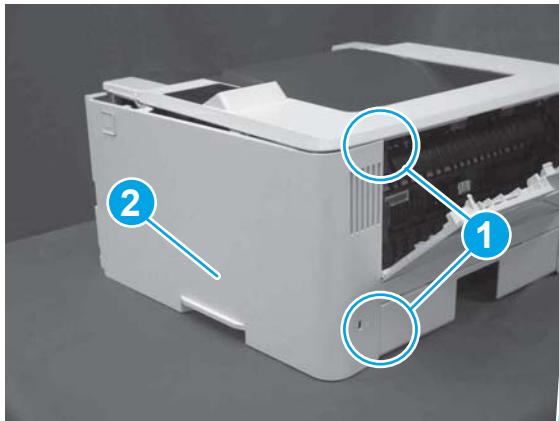

Step 6: Remove the integrated scanner assembly (M427/M246)

 **NOTE:** M427/M426 models only. The integrated scanner assembly (ISA) includes the sub-scanner assembly (SSA) and the automatic document feeder (ADF).

1. Raise the ISA.

Figure 1-1973 Raise the ISA

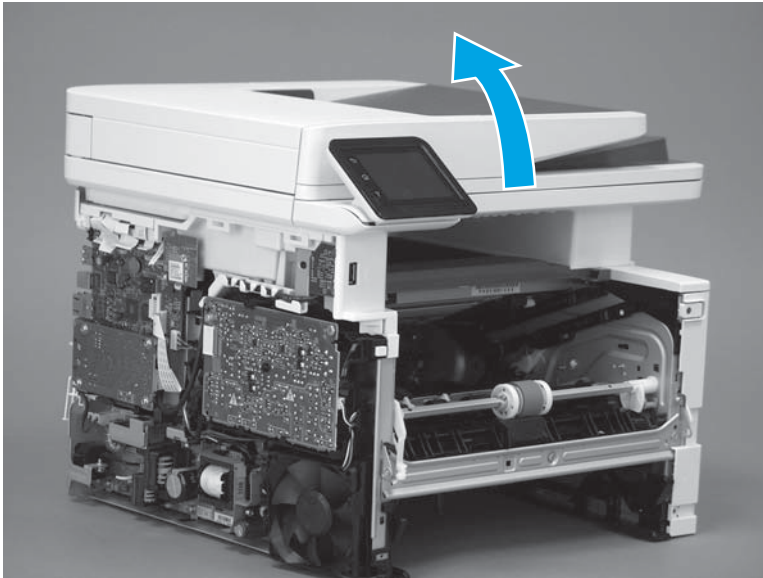

2. Release the ISA flat-flexible cable (FFC) cover (callout 1), and then remove it (callout 2).

Figure 1-1974 Remove the ISA FFC cover

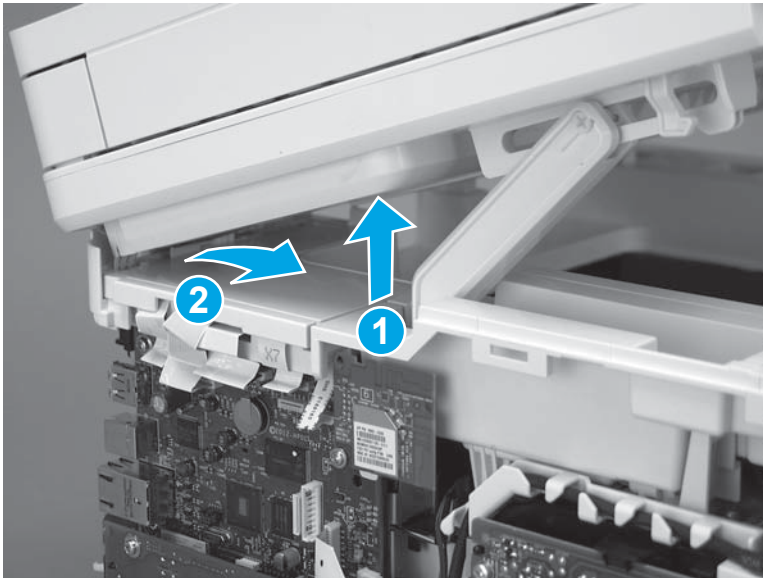

3. Disconnect three FFCs (callout 1), and then remove the ferrite (callout 2) from the holder.

CAUTION: The ferrite is not captive on the FFC. Do not lose the ferrite while handling the ISA.

Figure 1-1975 Disconnect three FFCs

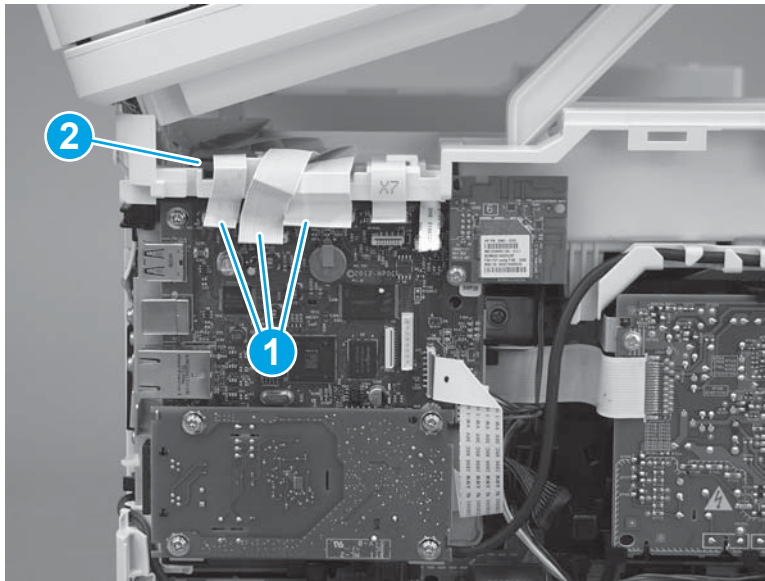

4. Remove one screw (callout 1).

Figure 1-1976 Remove one screw

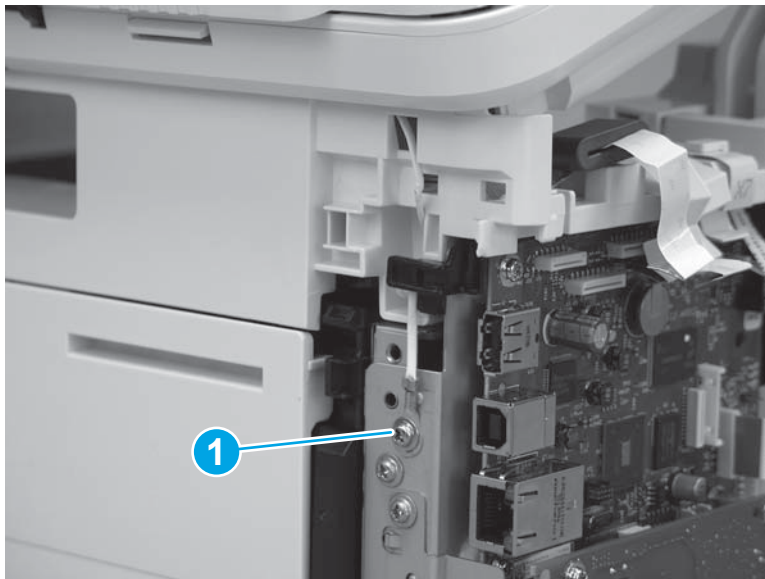

5. Pass the ground wire through the opening in the top cover.

Figure 1-1977 Pass the wire through the opening

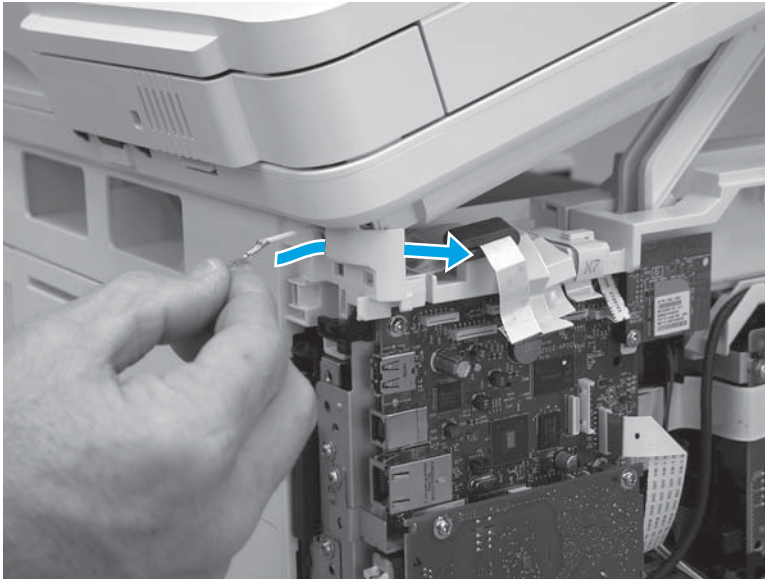

6. Release one tab (callout 1), and then rotate the ISA slider pin (callout 2) towards the front of the printer to release it.

Figure 1-1978 Release one tab and rotate the slider pin

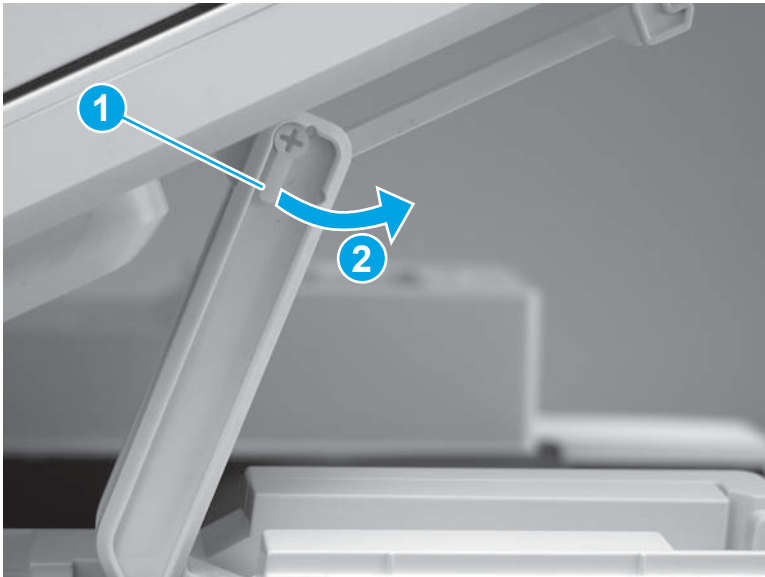

7. Remove the slider pin.

Figure 1-1979 Remove the slider pin

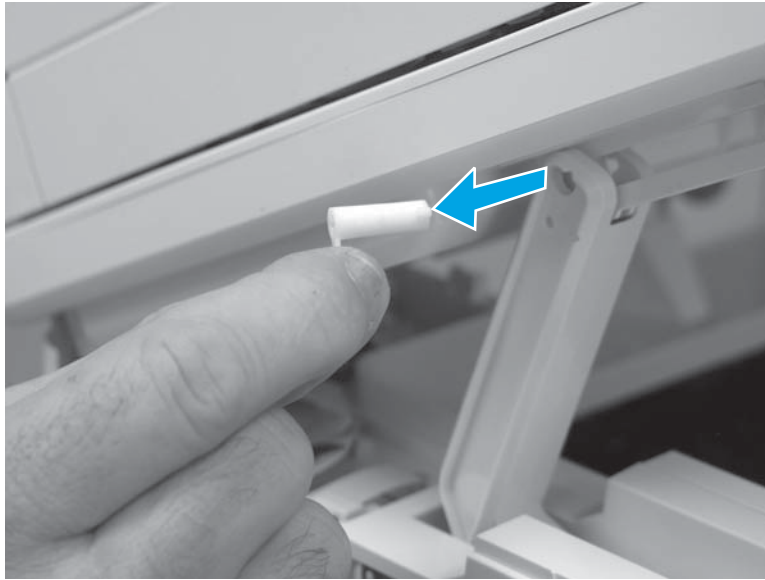

8. Rotate the ISA towards the rear of the printer until it stops.

Figure 1-1980 Rotate the ISA towards the rear of the printer



9. Slide the ISA as shown to release it.

Figure 1-1981 Release the ISA

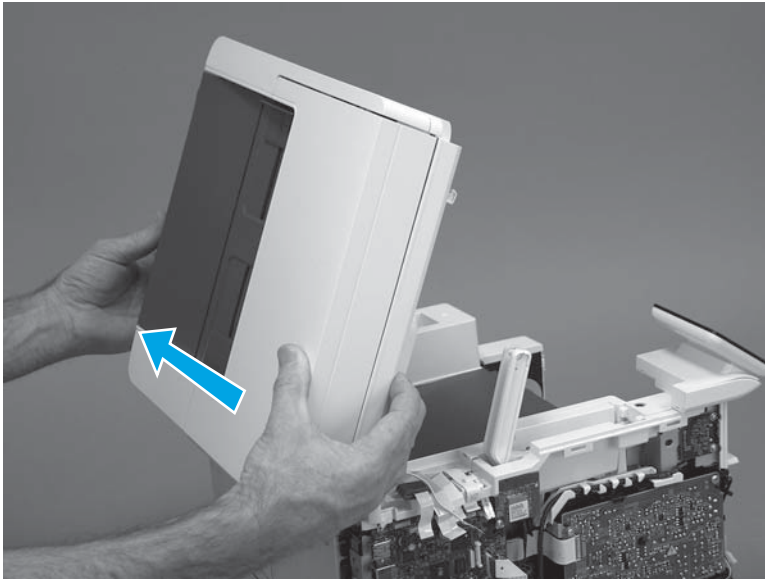

10. Remove the ISA.

Figure 1-1982 Remove the ISA

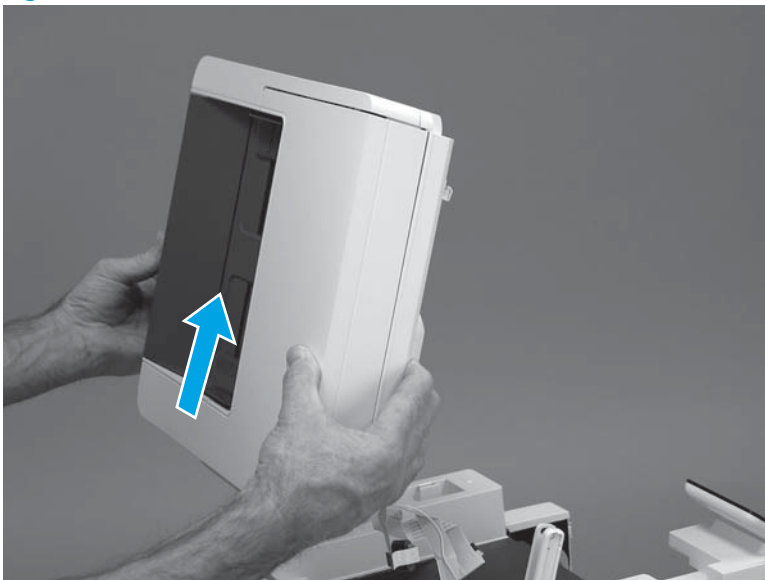

Step 5: Remove the control panel (M427/M426)

1. Disconnect one FFC (callout 1; J114), and then release the FFC from the retainer (callout 2).

Figure 1-1983 Disconnect one connector

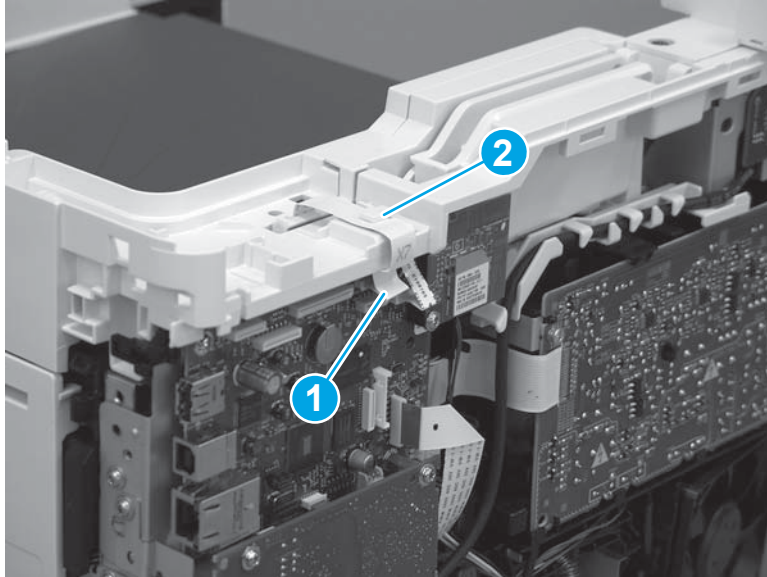

2. Remove one screw (callout 1).

Figure 1-1984 Remove one screw

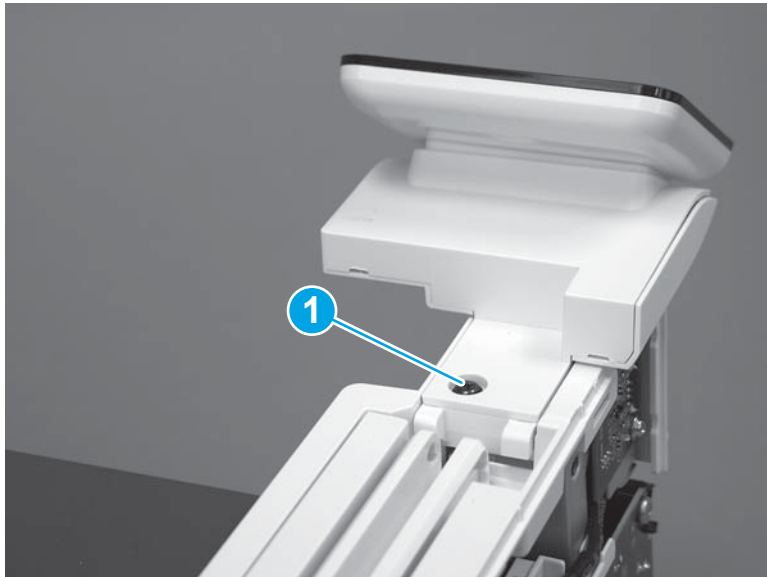

3. Use a small flat-blade screwdriver to release two tabs (callout 1) on the control-panel cable cover.

Figure 1-1985 Release two tabs

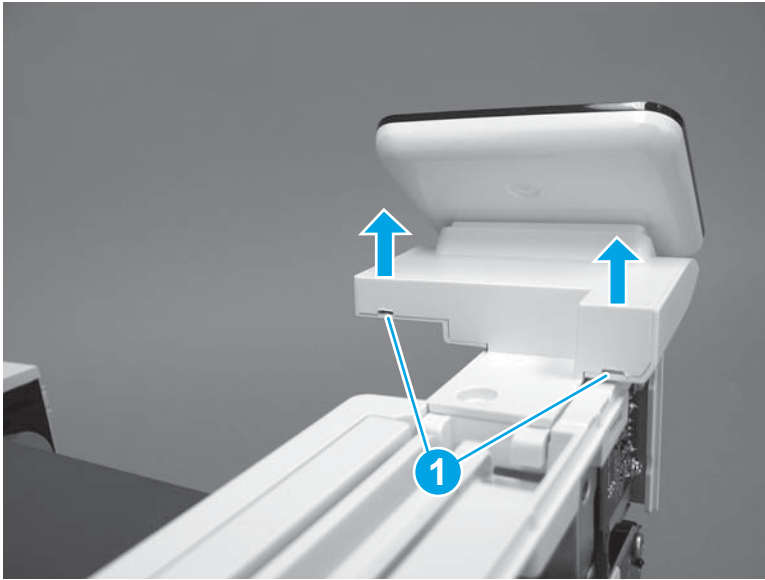

4. Remove the control-panel cable cover.

Figure 1-1986 Remove the cover

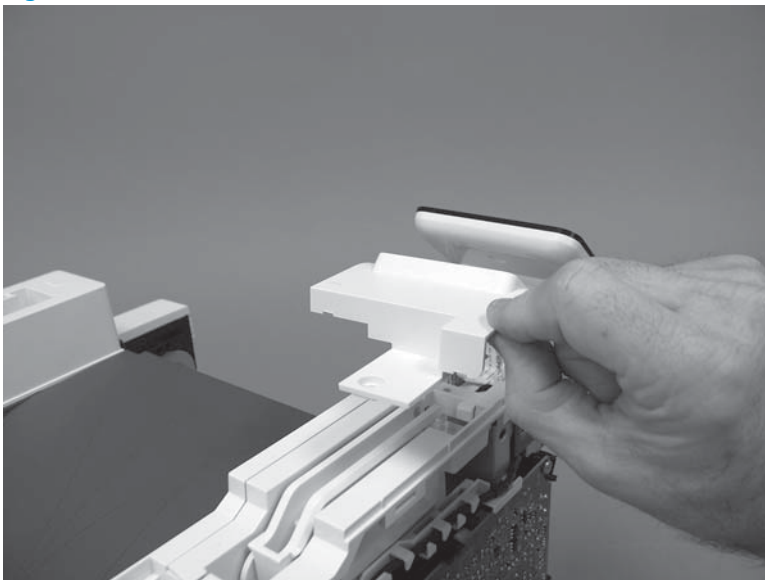

5. Remove one grounding screw (callout 1), and then move the ground cable (callout 2) out of the way.

Figure 1-1987 Remove one screw

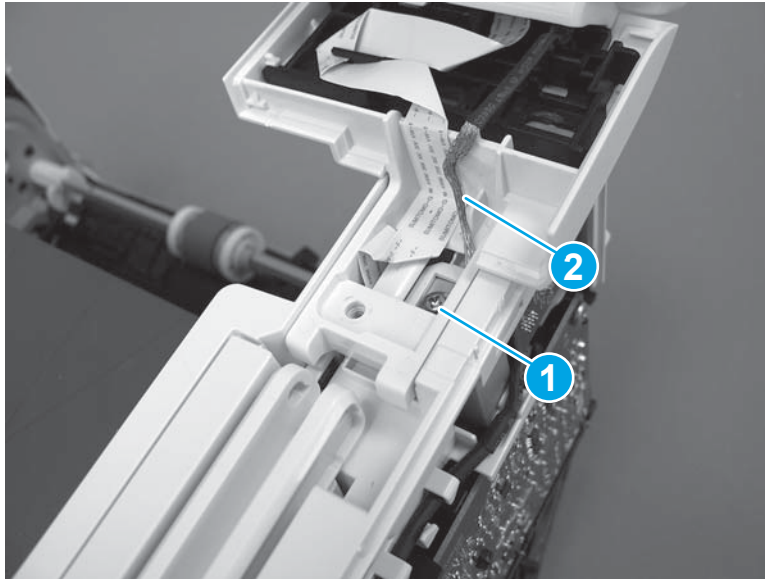

6. Move the FFC out of the way, and then remove two screws (callout 1).

Figure 1-1988 Remove two screws

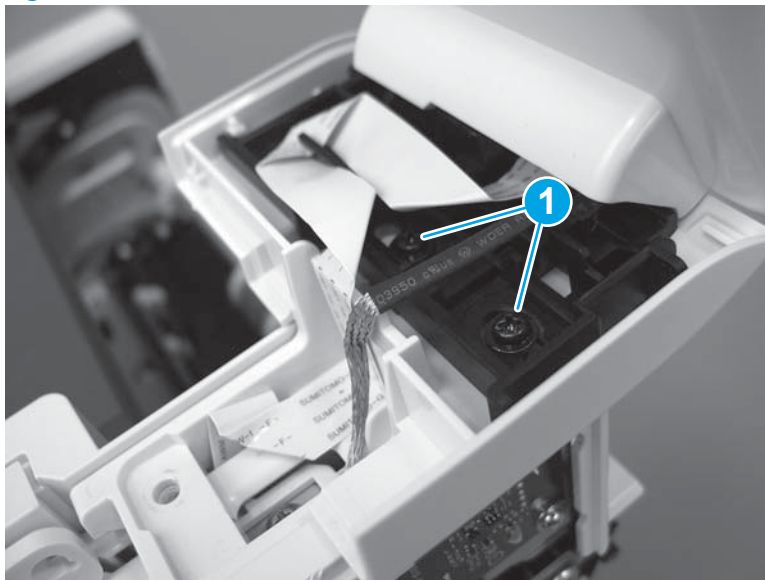

7. Slightly lift up the control-panel assembly to separate it from the top cover.

⚠ CAUTION: The control panel assembly is still connected to the printer by the FFC. Do not attempt to completely remove the assembly.

Figure 1-1989 Lift up the control-panel assembly

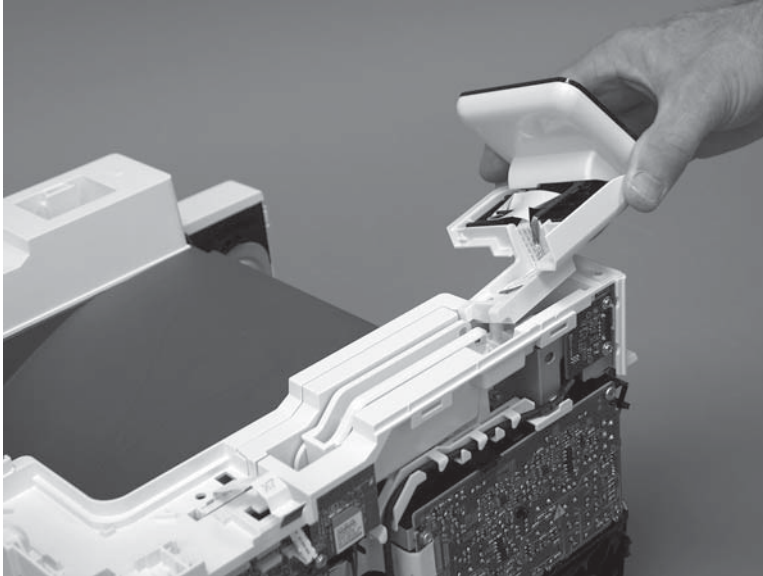

8. Lift up the control-panel FFC cover to remove the control-panel assembly.

Figure 1-1990 Remove the control-panel assembly

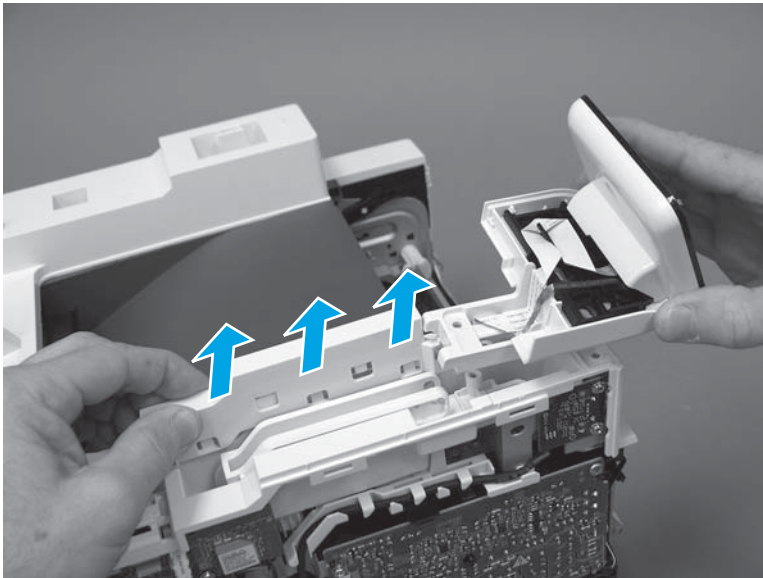

Step 7: Remove the top cover (M427/M426)

1. Release the USB cable (callout 1) from the cable guide.

Figure 1-1991 Remove the USB cable

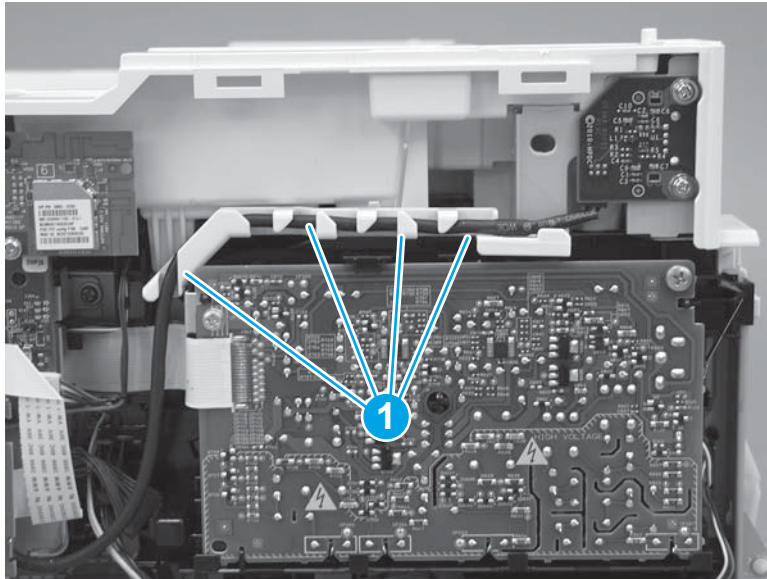

2. Remove five screws (callout 1), release four bosses (callout 2), and then remove the top cover (callout 3).

Figure 1-1992 Remove the cover

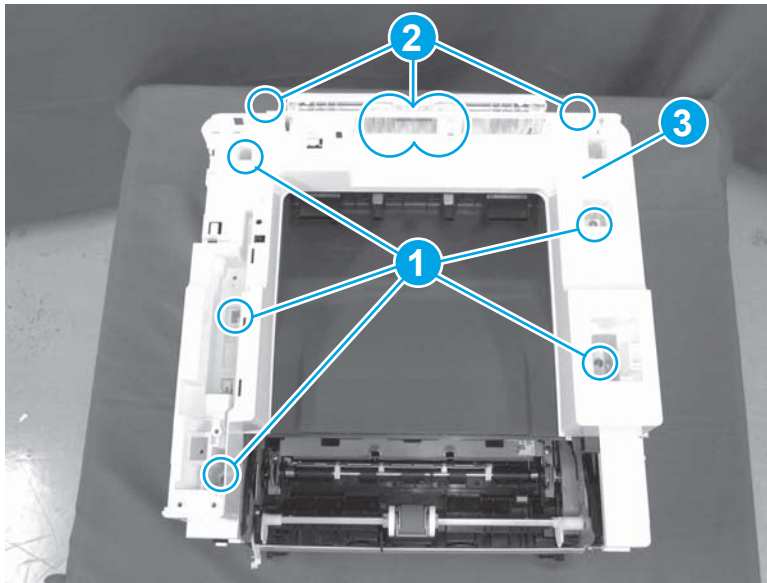

Step 8: Remove the NFC cover (M427/M426)

- ▲ Carefully pull up on the NFC cover (callout 1) to remove it.

⚠ CAUTION: Do not damage the NFC PCA when removing the cover.

Figure 1-1993 Remove the cover

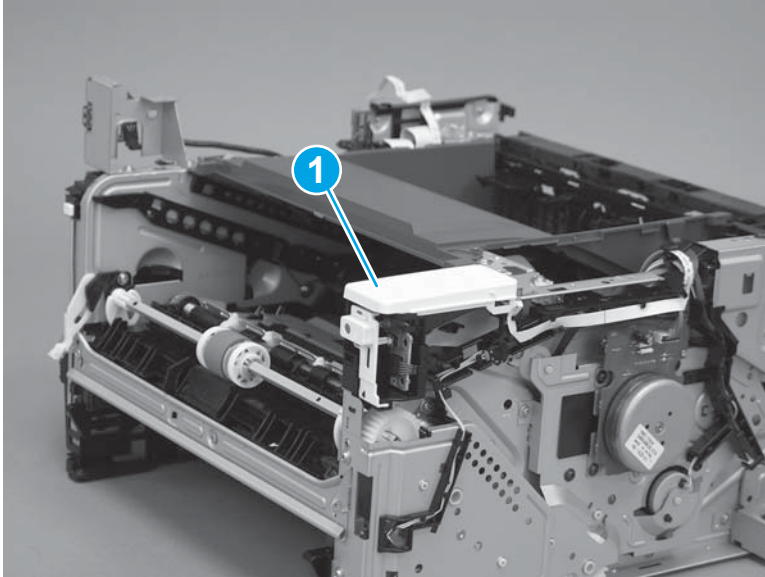

Step 9: Unpack the replacement assembly

Unpack the replacement part from the packaging.

<http://www8.hp.com/us/en/hp-information/environment/product-recycling.html>

 **NOTE:** HP recommends responsible disposal of the defective part.

Figure 1-1994 Recycle and unpack

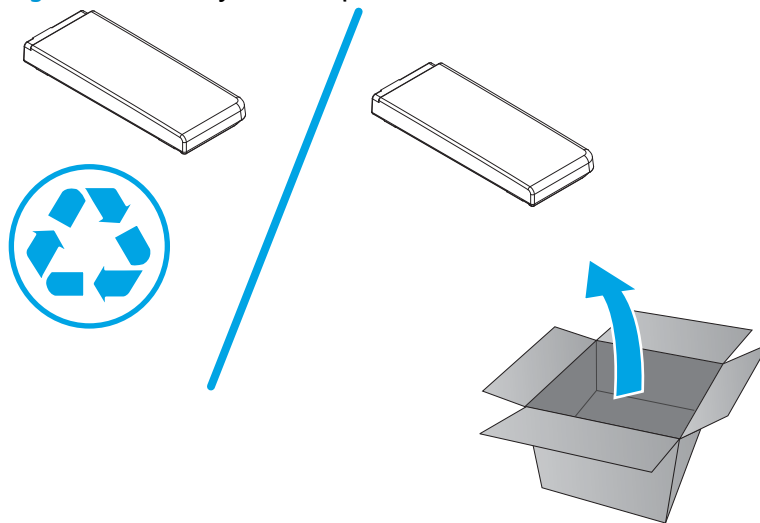

Step 10: Install the NFC cover (M427/M426)

▲ Carefully install the NFC cover on the printer.

 **CAUTION:** Do not damage the NFC PCA when installing the cover.

Figure 1-1995 Remove the cover

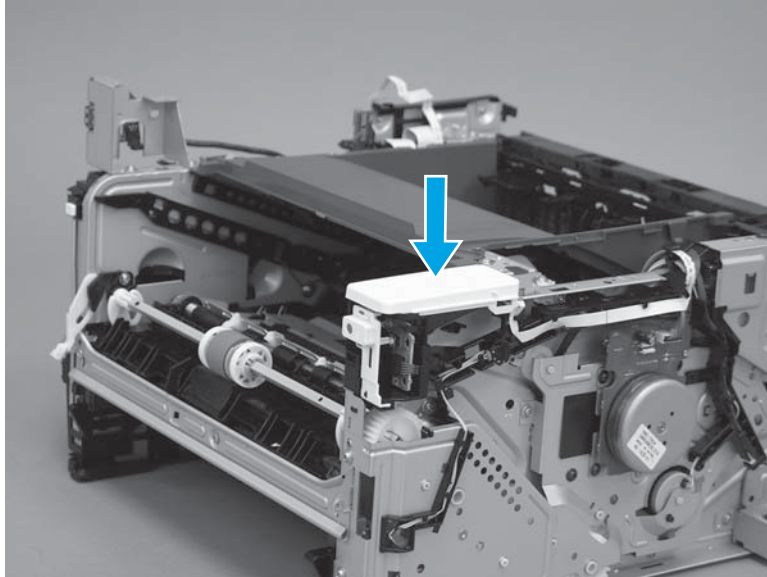

Step 11: Install the top cover (M427/M426)

1. Position the rear edge of the top cover on the printer.

Figure 1-1996 Install the cover

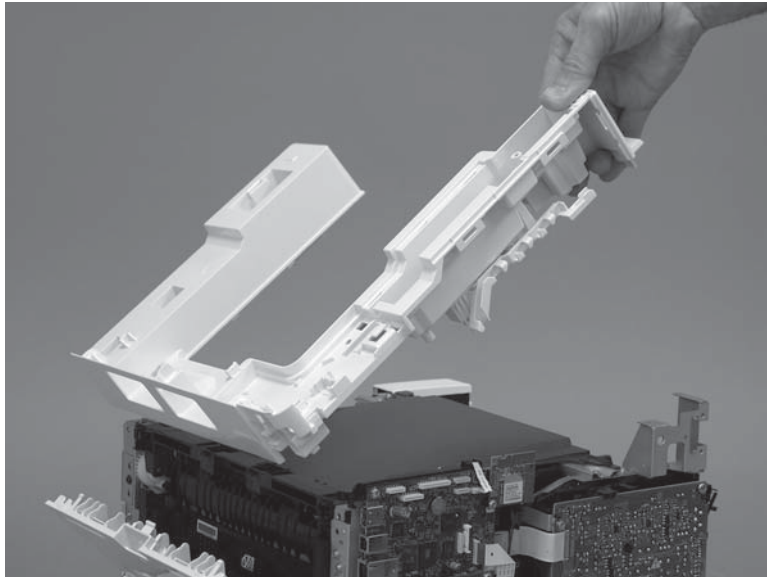

2. Engage four bosses (callout 1).

Figure 1-1997 Engage four bosses

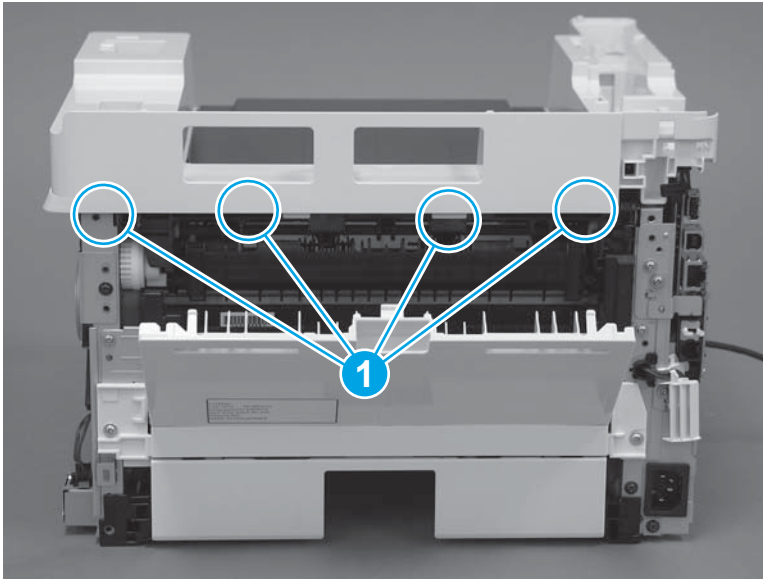

3. Rotate the front edge of the cover down.

Figure 1-1998 Rotate the front edge of the cover down

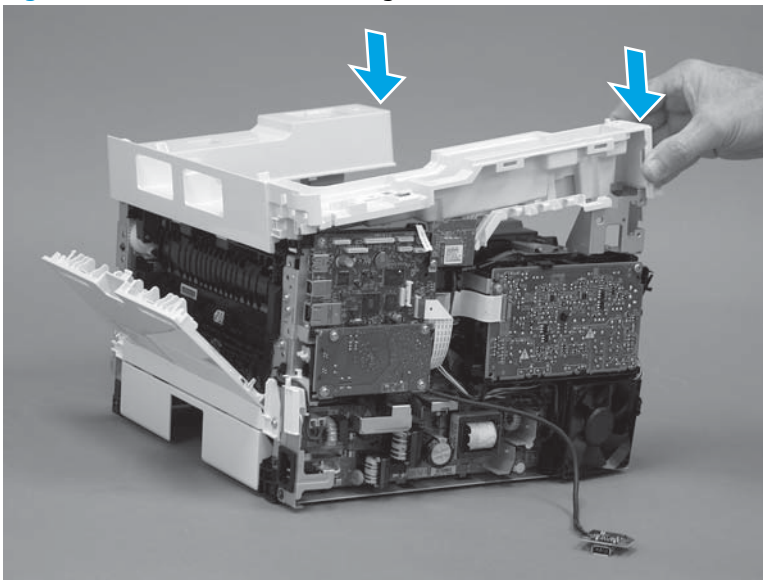

4. Install the USB cable (callout 1) in the guide.

Figure 1-1999 Install the USB PCA

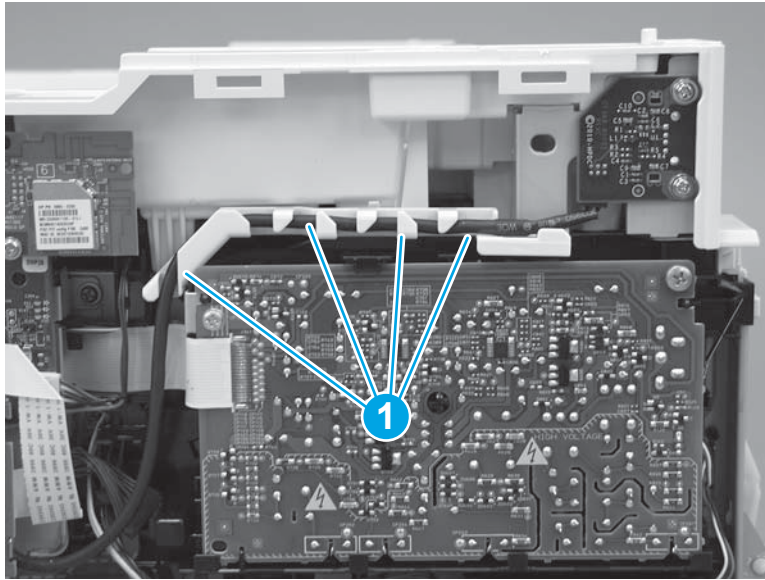

5. Install five screws (callout 1).

Figure 1-2000 Install five screws

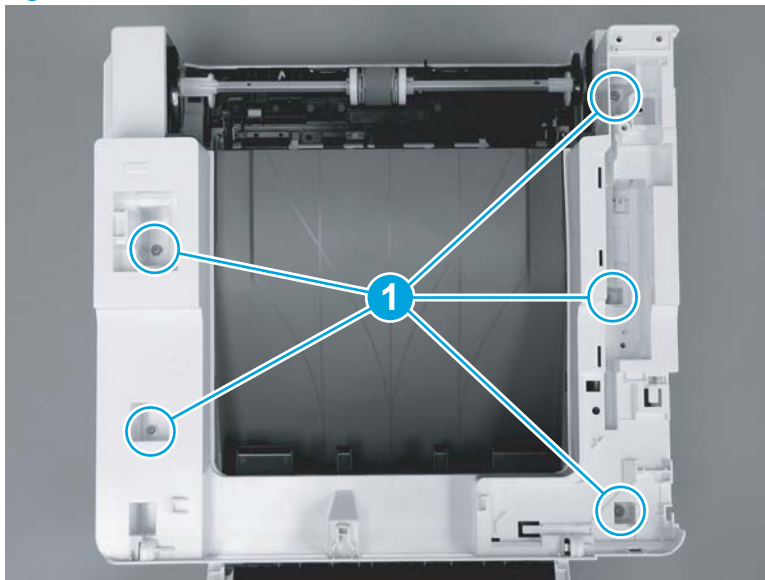

Step 12: install the control panel (M427/M426)

1. Slide the control-panel FFC cover into the slot in the top cover (next to the document feeder support arm) to install it.

Figure 1-2001 Install the control-panel FFC cover

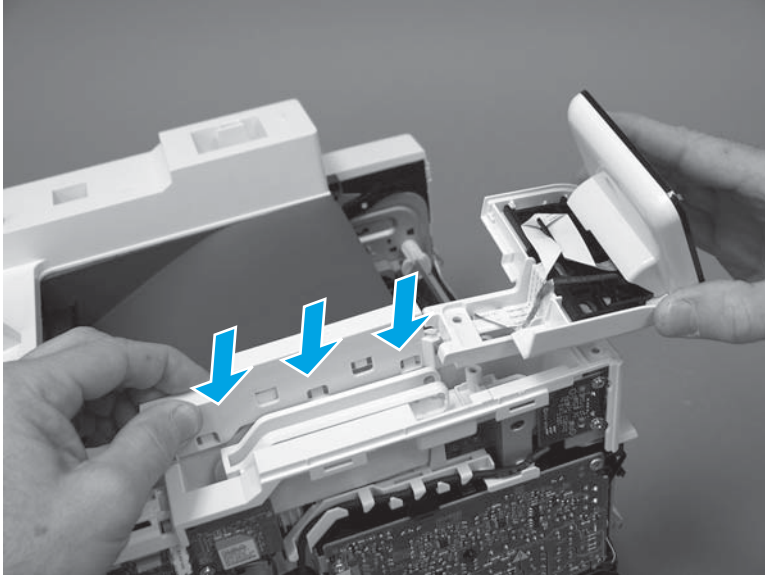

2. Install the control-panel assembly on the top cover.

Figure 1-2002 Install the control-panel assembly

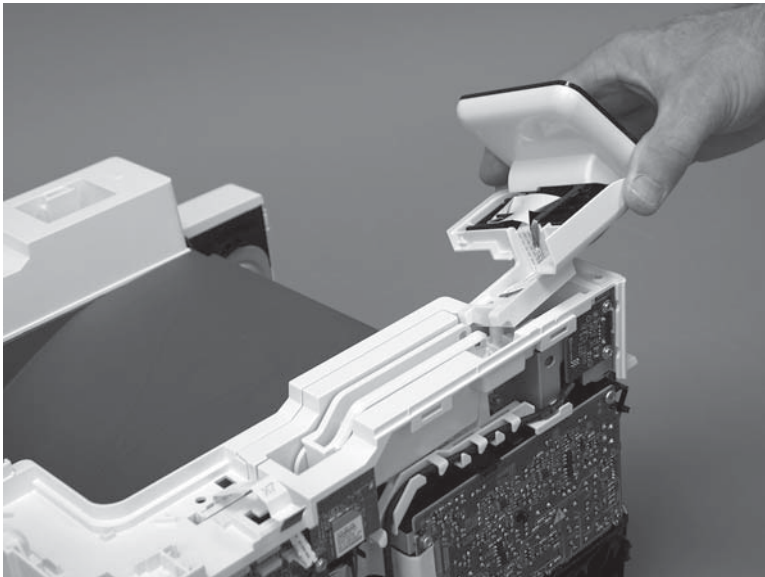

3. Move the FFC out of the way, and then install two screws (callout 1).

Figure 1-2003 Install two screws

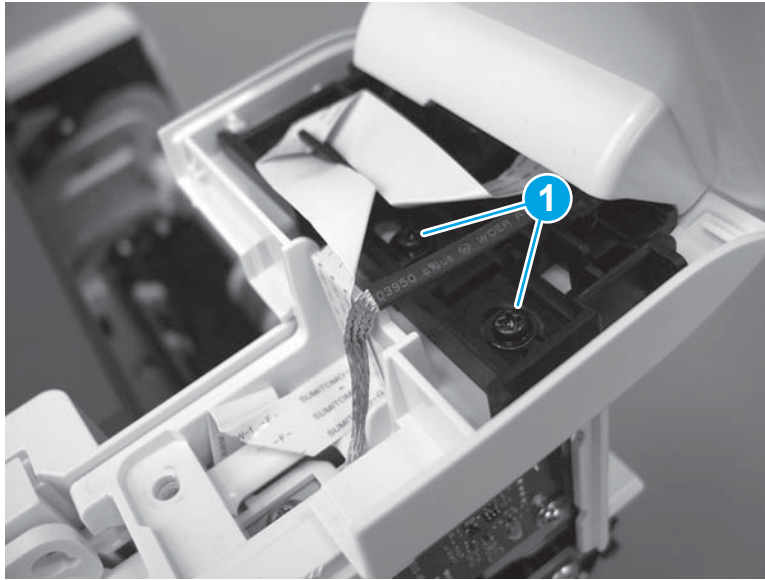

4. Install one grounding screw (callout 1), and then make sure that the ground cable (callout 2) is properly routed.

Figure 1-2004 Remove one screw

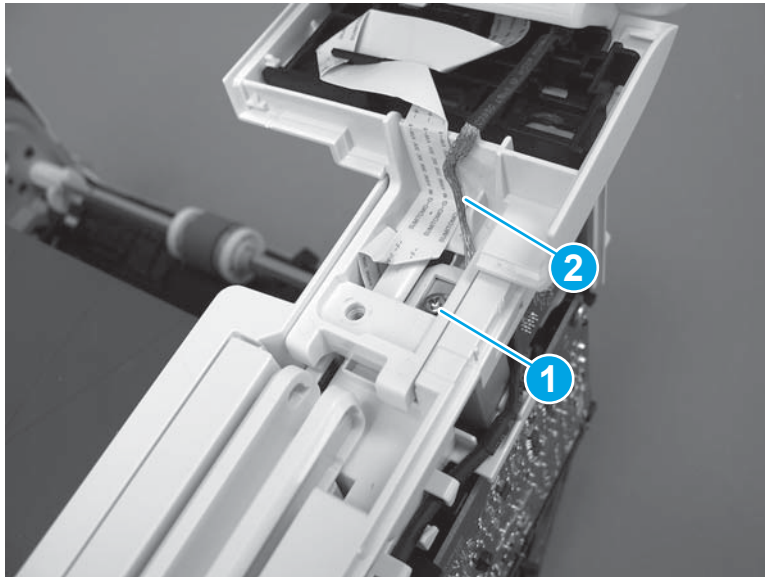

5. Install the control-panel cable cover.

Figure 1-2005 Install the cover

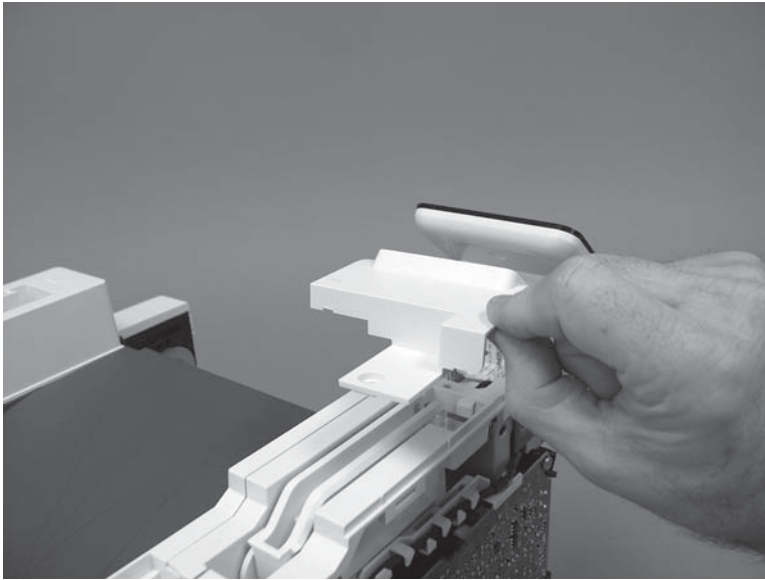

6. Make sure that the two tabs (callout 1) on the cover snap into place.

Figure 1-2006 Engage two tabs

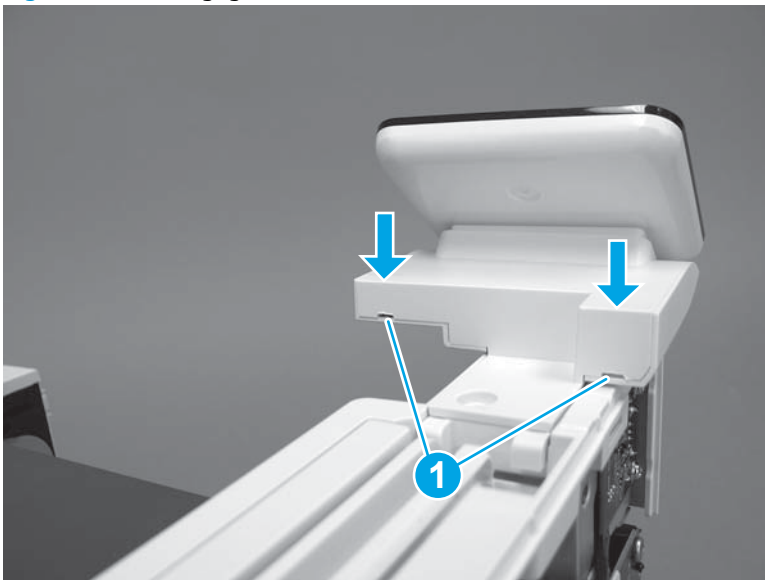

7. Install one screw (callout 1).

Figure 1-2007 Install one screw

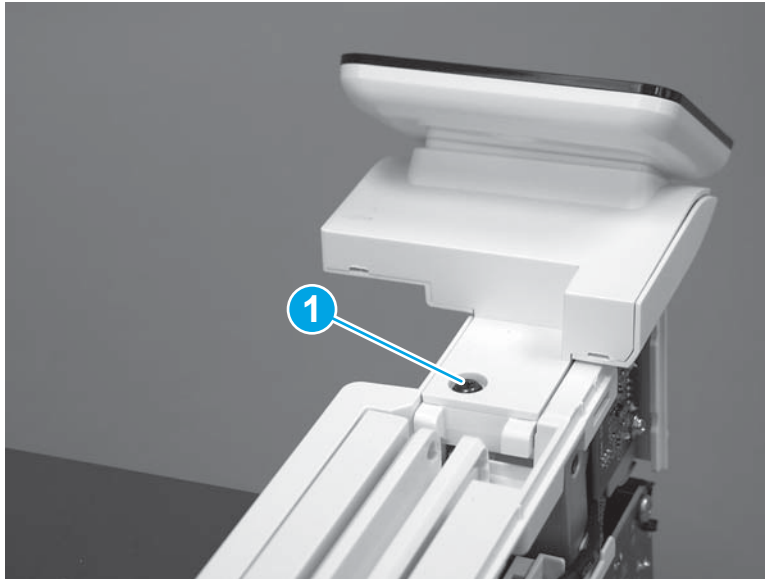

8. Install the FFC in the retainer (callout 1), and then connect one FFC (callout 1; J114).

Figure 1-2008 Connect one connector

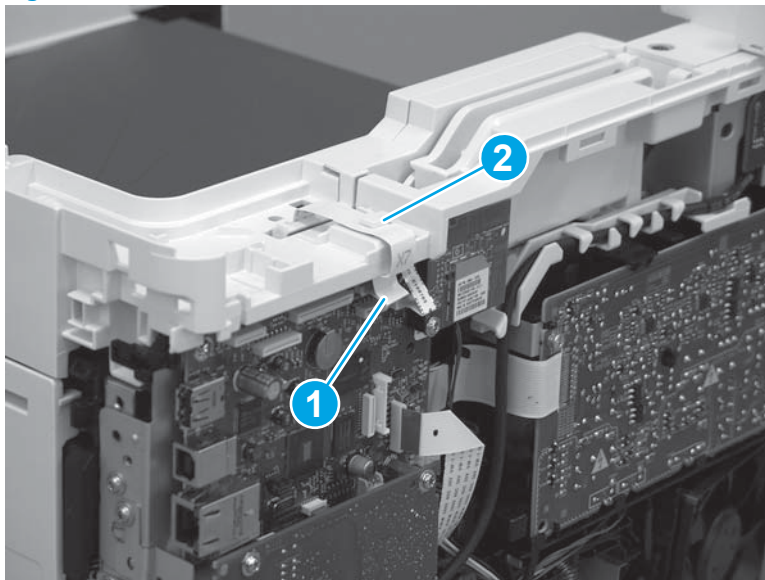

Step 12: Install the integrated scanner assembly (M427/M246)

 **NOTE:** M427/M426 models only. The integrated scanner assembly (ISA) includes the sub-scanner assembly (SSA) and the automatic document feeder (ADF).

1. Position the ISA on the printer.

Figure 1-2009 Position the ISA on the printer

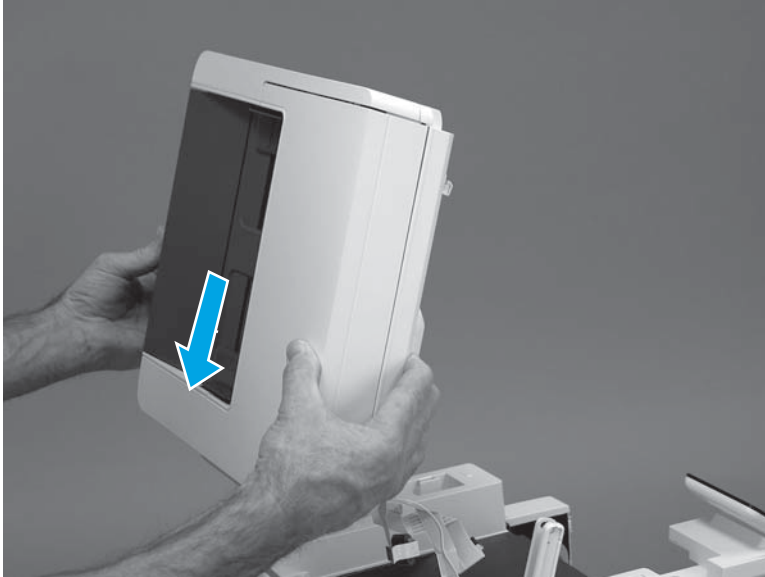

2. Engage the hinge pins on the ISA with the holders in the top cover (callouts 1/2), and then slide the ISA as shown to engage them

Figure 1-2010 Engage the hinge pins with the holders

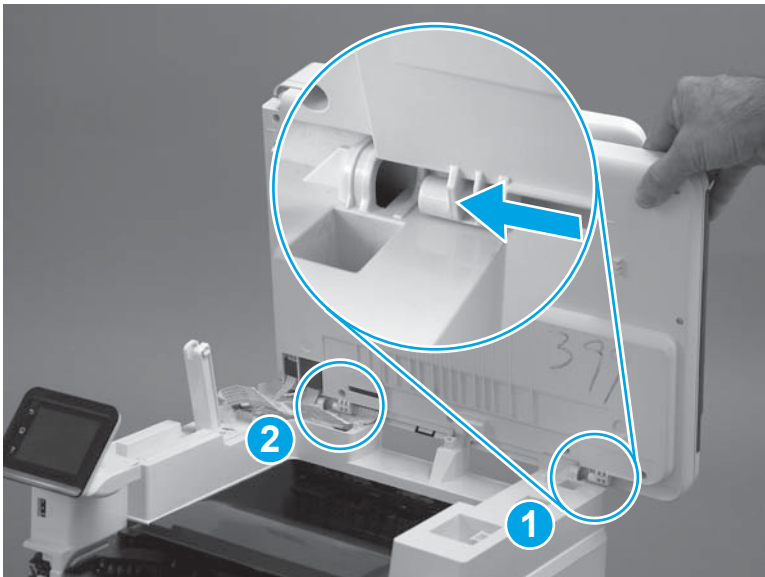

3. Rotate the ISA towards the front of the printer until it rests on the ISA lift assembly (callout 1).

Figure 1-2011 Rotate the ISA towards the front of the printer

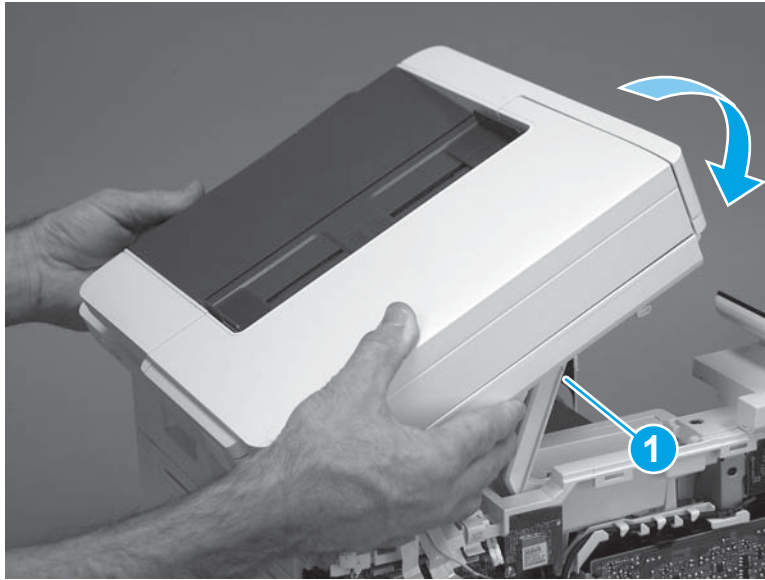

4. Pass the ground wire through the opening in the top cover.

Figure 1-2012 Pass the wire through the opening

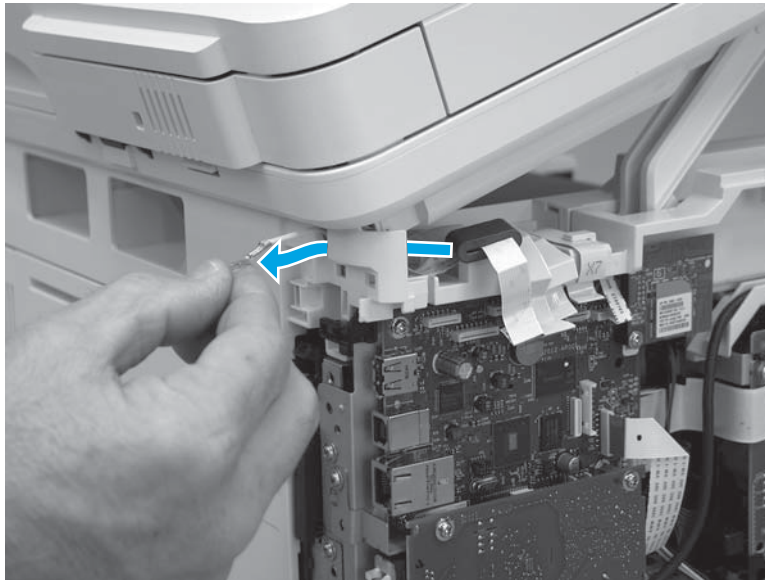

5. Install one screw (callout 1).

Figure 1-2013 Install one screw

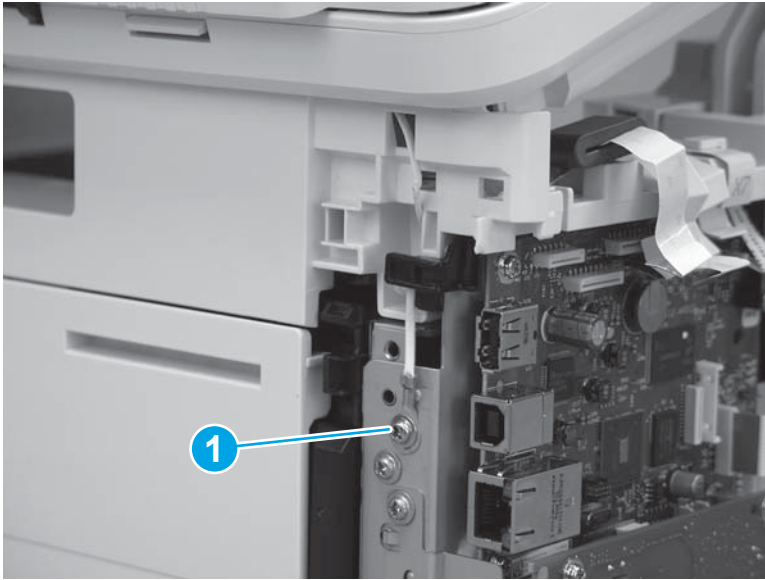

6. Install the ISA lift assembly slider pin.

 **Reinstallation tip:** Align the keyed portion of the locking pin with the slot and hole in the support arm.

Figure 1-2014 Install the slider pin



7. Rotate the slider pin (callout 1) towards the rear of the printer until the tab (callout 2) snap into place.

Figure 1-2015 Secure the slider pin

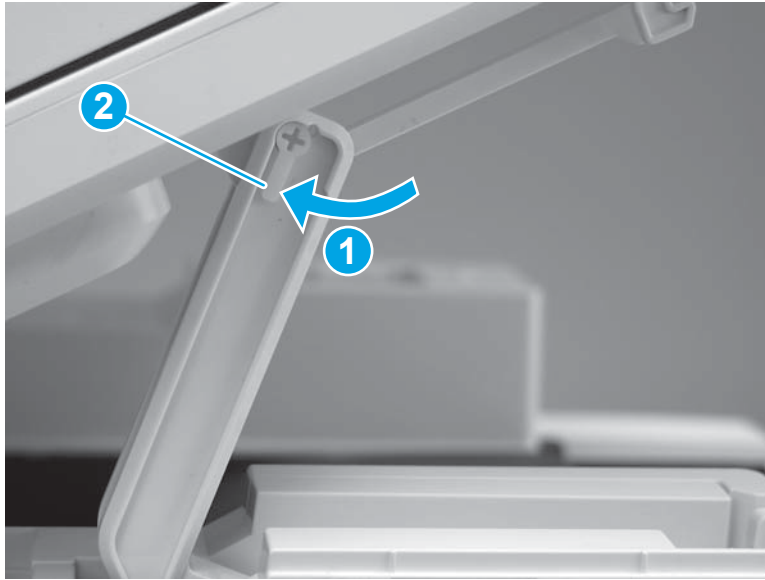

8. Install the ferrite (callout 1) in the holder, and then connect three FFCs (callout 2).

Figure 1-2016 Connect three FFCs

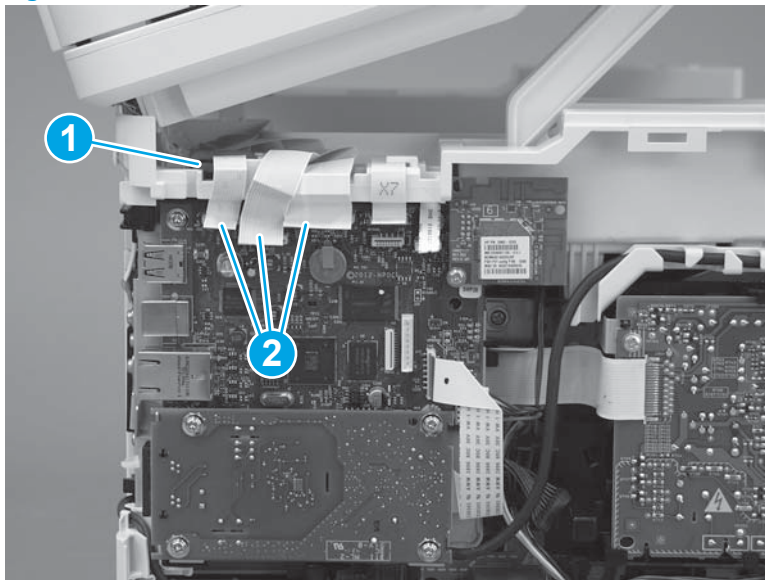

9. Position the rear edge of the ISA flat-flexible cable (FFC) cover on the printer (callout 1) , and then rotate it down (callout 2) until it snaps into place.

Figure 1-2017 Install the ISA FFC cover

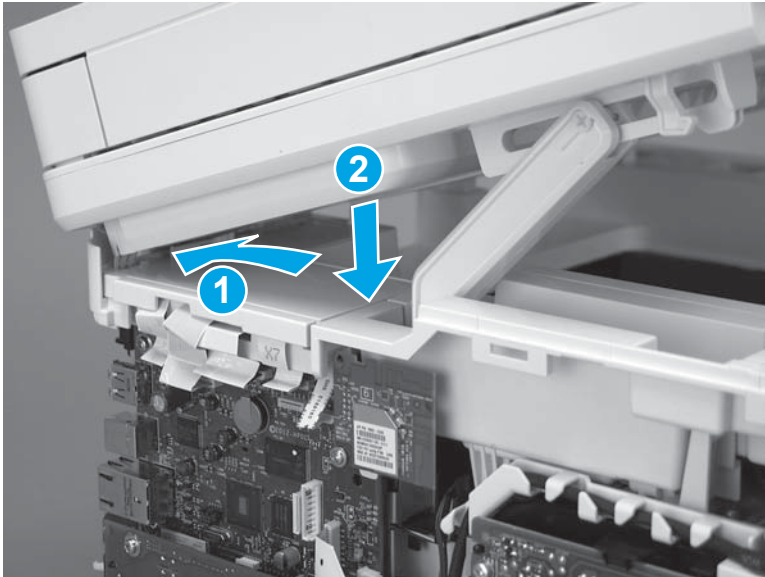

10. Lower the ISA.

Figure 1-2018 Lower the ISA

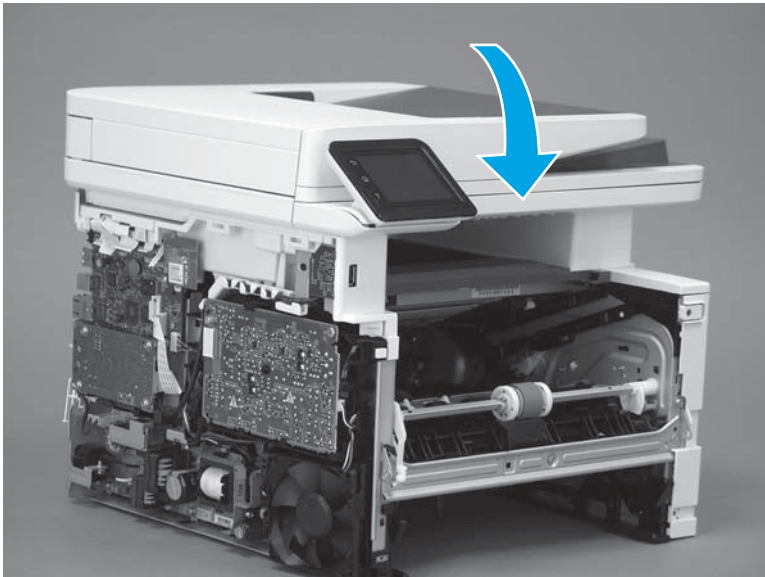

Step 13: Install the right cover

1. Position the cover (callout 1) on the printer, and then engage two bosses (callout 2).

Figure 1-2019 Install the cover

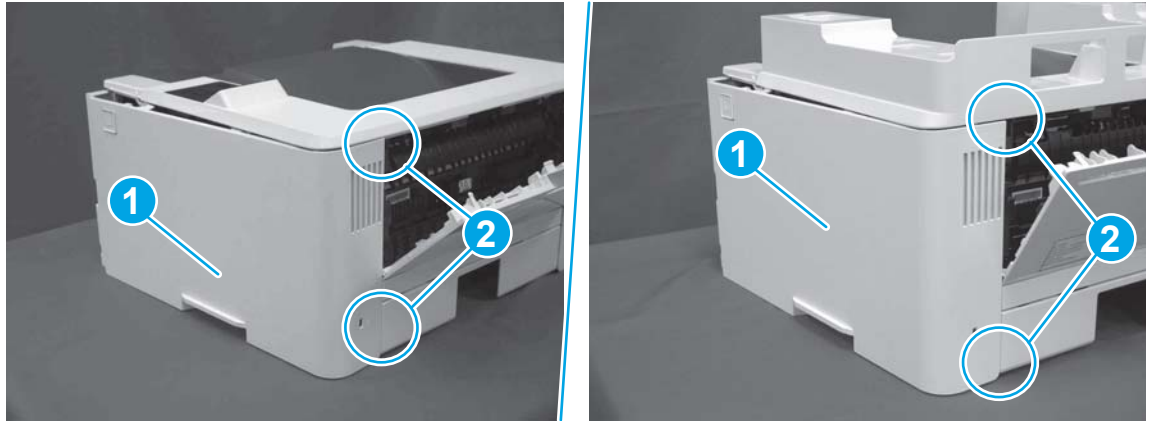

2. Rotate the front of the cover onto the printer (callout 1), engage three (callout 2) tabs, and then engage two bosses (callout 3).

Figure 1-2020 Engage two bosses and one tab

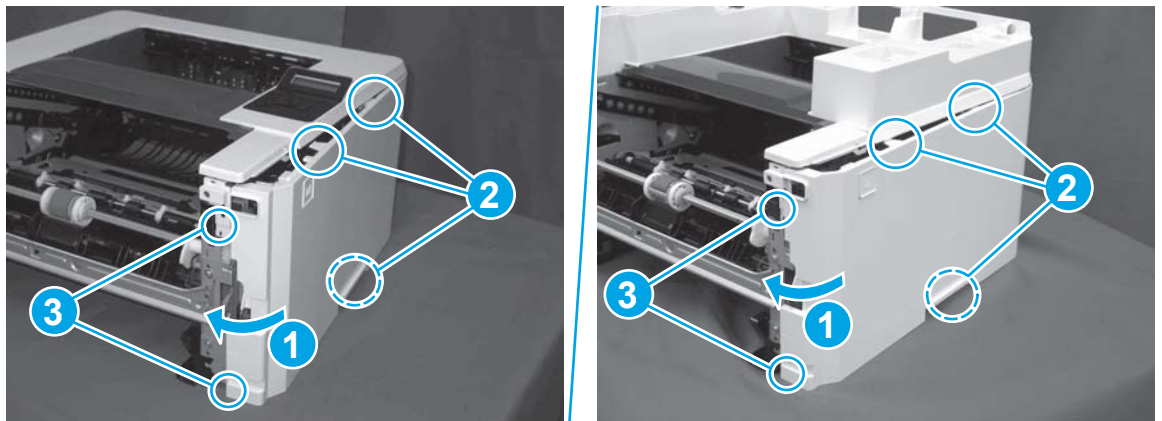

3. Make sure that the power switch (callout 1) and cartridge door assembly button (callout 2) correctly function.

 **NOTE:** Remove, and then reinstall the cover if the switch or button does not correctly function.

Figure 1-2021 Check the power switch and cartridge door assembly button

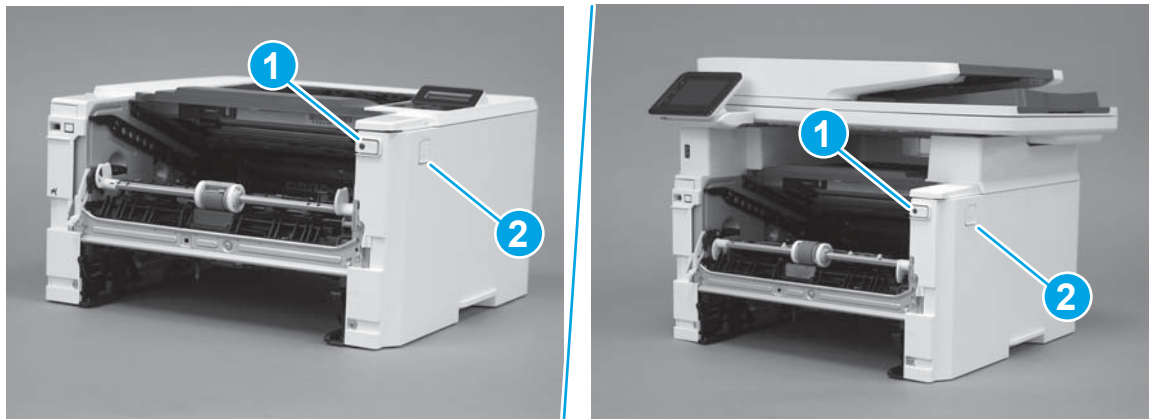

4. Install one screw (callout 1).

Figure 1-2022 Install one screw



Step 14: Install the left cover

1. At the front of the printer, do one of the following:
 - **M403/M402:** Position the cover on the printer (callout 1), and then engage two bosses (callout 2).
 - **M427/M426:** Position the cover on the printer (callout 3), engage one tab (callout 4), and then engage two bosses (callout 4).

Figure 1-2023 Install the cover

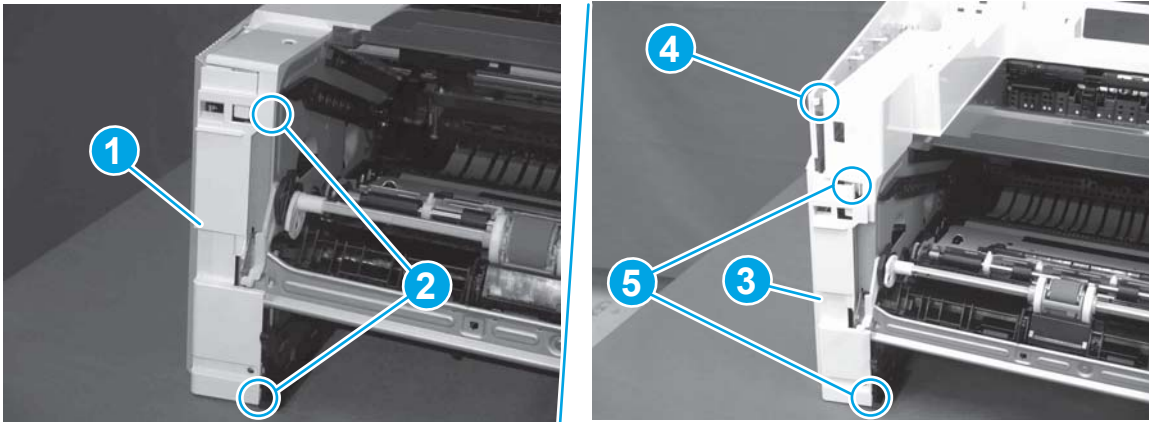

- Carefully rotate the rear of the cover onto the printer (callout 1), engage three tabs (callout 2), and then engage two bosses (callout 3).

Figure 1-2024 Engage three tabs and two bosses

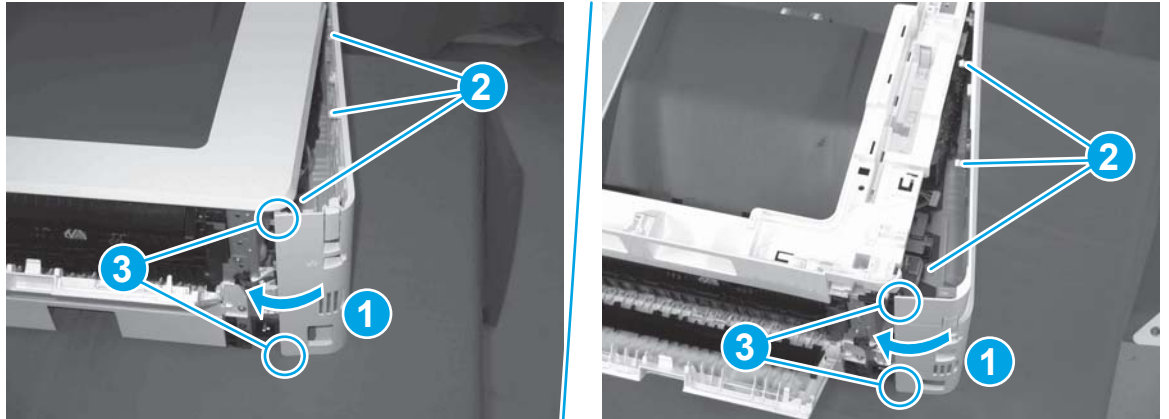

- Install one screw (callout 1).

Figure 1-2025 Install one screw

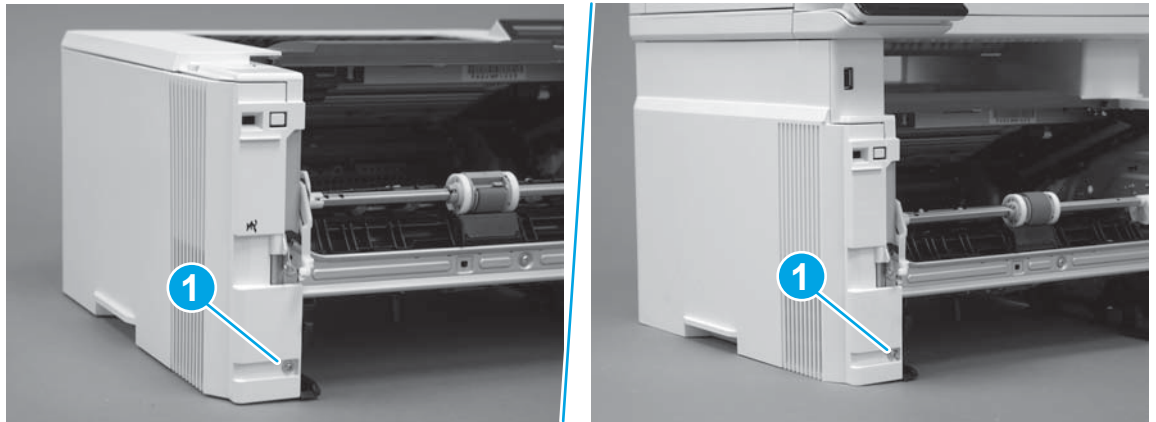

Step 15: Remove the cartridge door assembly

Reinstallation tip: After a replacement door is installed, make sure to install the nameplate (supplied in the kit) corresponding to the printer name on the door.

- Position the door close to the printer, and then engage the keyed pin on the left-side retainer arm with the hole in the door.

Figure 1-2026 Engage the left-side retainer arm

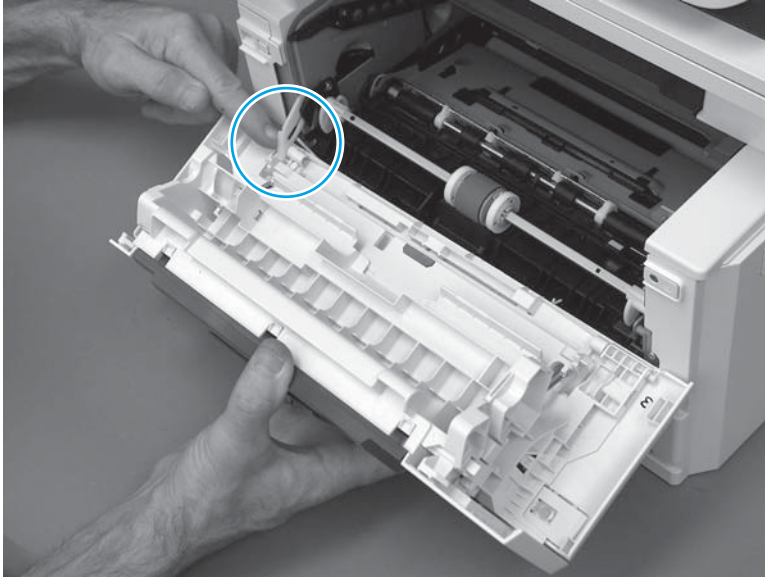

2. Engage the right-side door hinge pin with the hole in the chassis (callout 1).

Figure 1-2027 Install the door

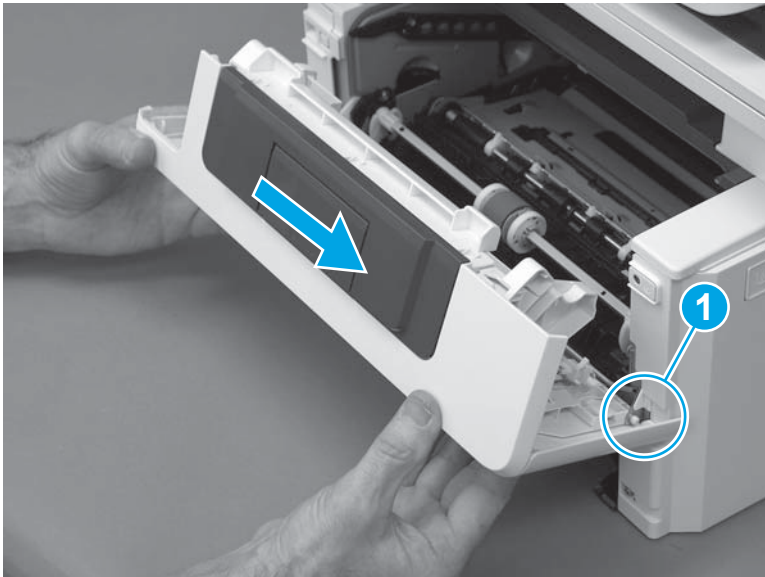

3. Install the link (callout 1).

 **IMPORTANT:** Make sure that the link snaps into place on the arm (callout 2). The link actuates the fuser pressure-release mechanism.

Figure 1-2028 Install the pressure-release link

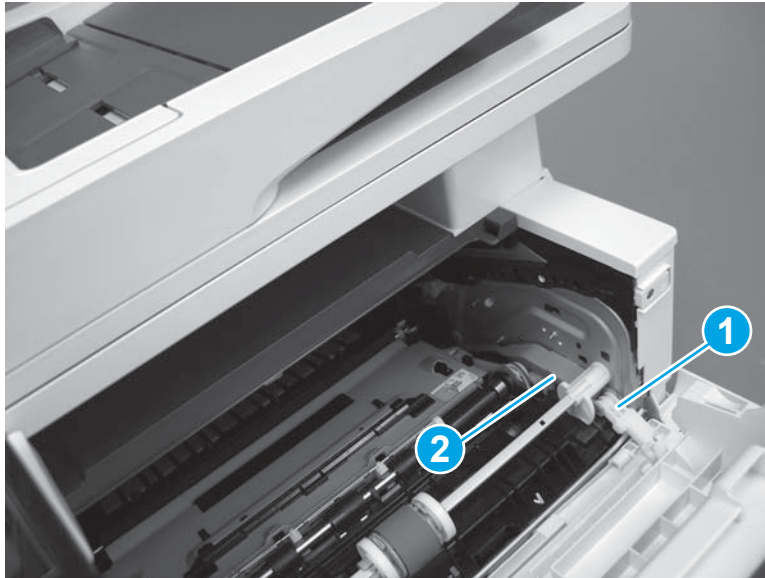

4. Slide the guide into the printer (callout 1), and then make sure that the tab (callout 2) snaps into place to secure the guide to the chassis.

Figure 1-2029 Install the guide

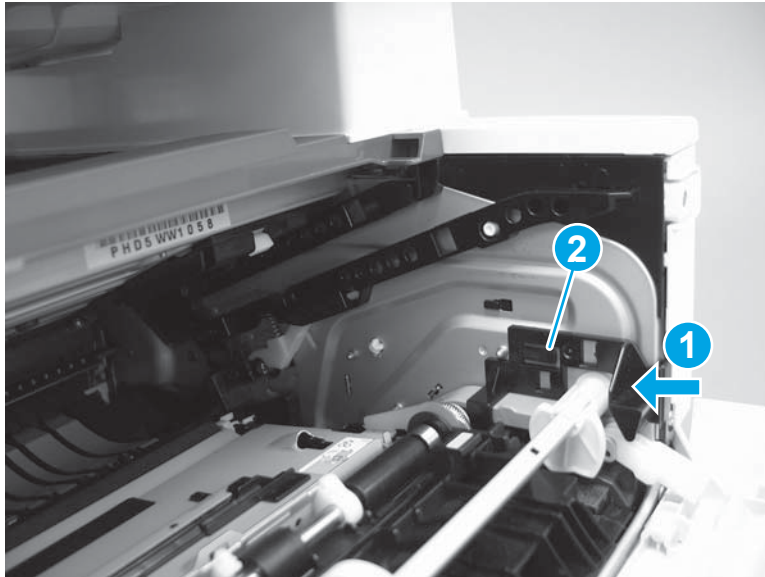

5. Position the shaft on the door, and then align the left-side hinge on the door with the hole in the chassis (callout 1).

Figure 1-2030 Align the hinge

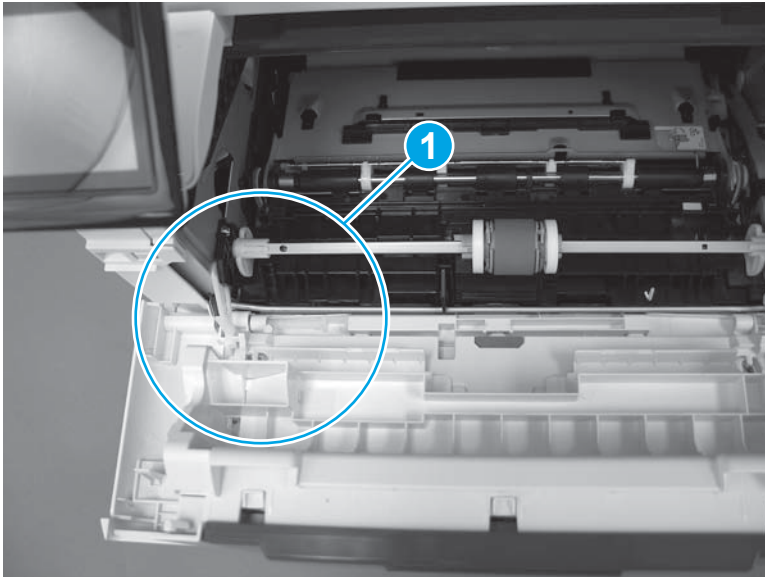

6. Push the shaft towards the left side of the printer to install it (callout 1).

 **Reinstallation tip:** Make sure that the support shaft is fully installed and correctly orientated (callout 2) so that it will not interfere with the door opening and closing.

Figure 1-2031 Install the support shaft



Step 16: Install Tray 2

- ▲ Slide the tray straight into the printer to install it.

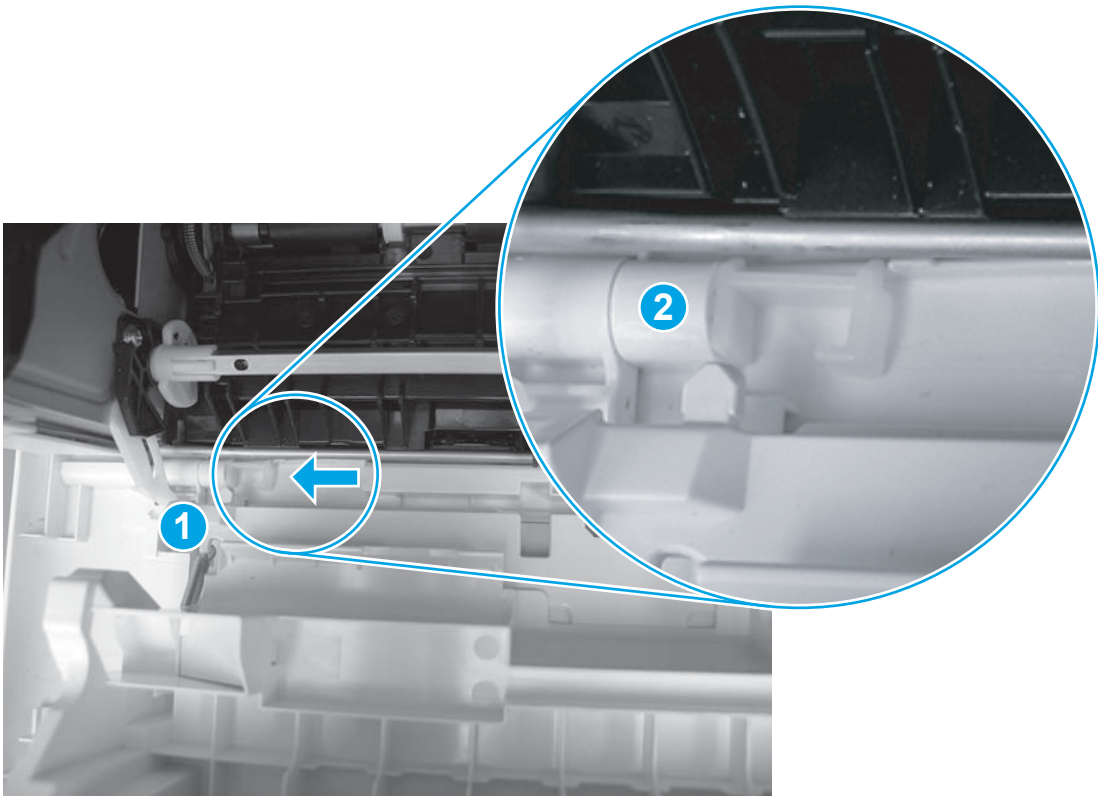
Figure 1-2032 Install the tray



Removal and replacement: NFC PCA



NOTE: M427fdw/M426fdw/M402dw/M403dw models only.

- [Introduction](#)
- [Step 1: Remove Tray 2](#)
- [Step 2: Remove the cartridge door assembly](#)
- [Step 3: Remove the left cover](#)
- [Step 4: Remove the right cover](#)
- [Step 5: Remove the integrated scanner assembly \(M427/M246\)](#)
- [Step 6: Remove the control panel \(M427/M426\)](#)
- [Step 7: Remove the top cover \(M427/M426\)](#)
- [Step 8: Remove the NFC cover \(M427/M426\)](#)
- [Step 9: Remove the top cover \(M403/M402\)](#)
- [Step 10: Remove the NFC PCA](#)
- [Step 11: Unpack the replacement assembly](#)
- [Step 12: Install the NFC PCA](#)
- [Step 13: Install the top cover \(M403/M402\)](#)
- [Step 14: Install the NFC cover \(M427/M426\)](#)
- [Step 15: Install the top cover \(M427/M426\)](#)
- [Step 16: Install the control panel \(M427/M426\)](#)
- [Step 17: Install the integrated scanner assembly \(M427/M246\)](#)
- [Step 18: Install the right cover](#)
- [Step 19: Install the left cover](#)
- [Step 20: Remove the cartridge door assembly](#)
- [Step 21: Install Tray 2](#)

Introduction

This document provides the procedures to remove and replace the near field communication (NFC) printed circuit assembly (PCA; M426fdw/M403dn models only).

Before performing service

Turn the printer power off

- Disconnect the power cable.

⚠ WARNING! To avoid damage to the printer, turn the printer off, wait 30 seconds, and then remove the power cable before attempting to service the printer.

Use the table below to identify the correct part number for your printer. To order the part, go to www.hp.com/buy/parts.

NFC PCA part number	
B4K93-60001	NFC PCA ¹

¹ M427fdw/M426fdw/M402dw/M403dw models only.

Required tools

- #2 Phillips screwdriver with a magnetic tip.

After performing service

Turn the printer power on

- Connect the power cable.
- Use the power switch to turn the power on.

Post service test

Make sure that the printer initializes to a **Ready** state.

Use a NFC enabled device to print a job from the printer.

Step 1: Remove Tray 2

- ▲ Pull the tray straight out of the printer to remove it.

Figure 1-2033 Remove the tray



Step 2: Remove the cartridge door assembly

 **NOTE:** If the toner cartridge was not removed prior to servicing the printer, remove it now.

1. Release one tab (callout 1), and then slide shaft (callout 2) in the direction the arrow indicates and remove it.

 **TIP:** It might be easier to release the support shaft by using a small flat-blade screwdriver.

Figure 1-2034 Release the support shaft

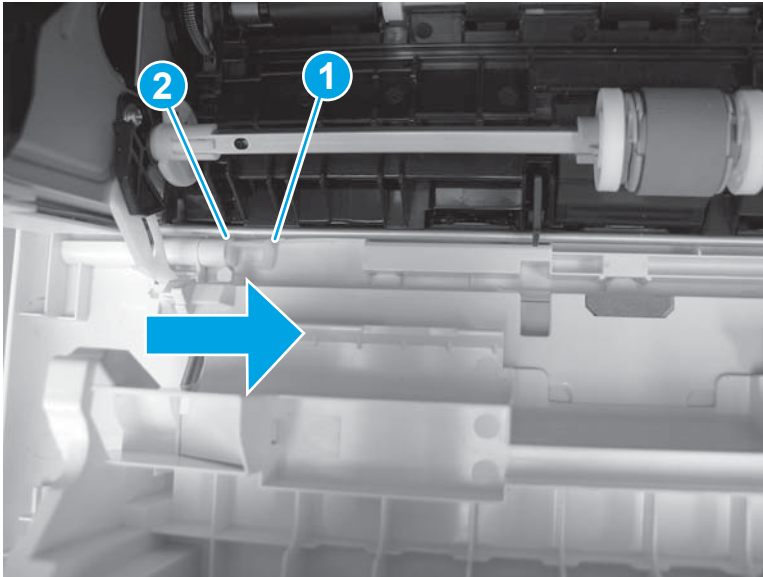

2. Release one tab (callout 1), and then slide the guide (callout 2) in the direction the arrow indicates and remove it.

Figure 1-2035 Remove the guide

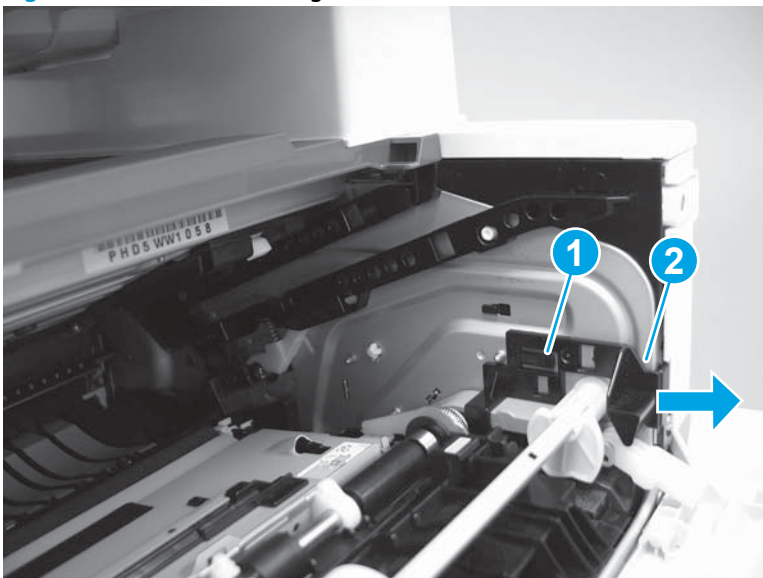

3. Remove the link arm (callout 1).

Figure 1-2036 Remove the link arm

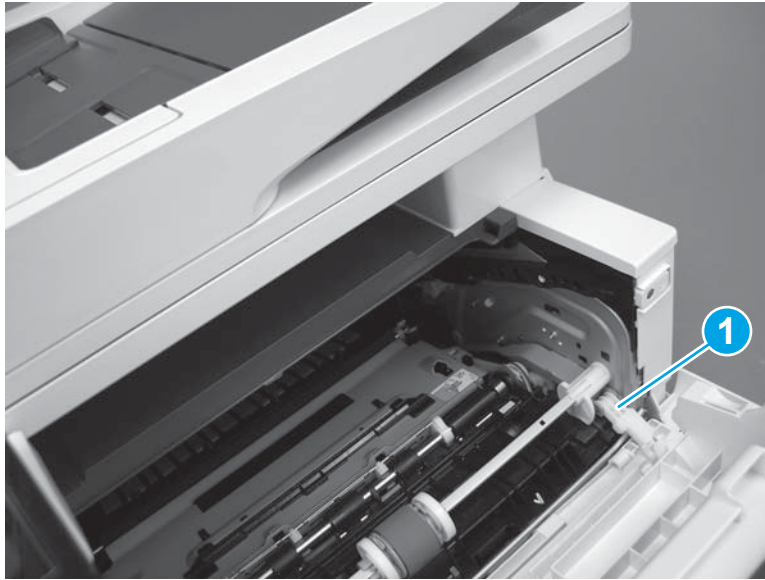

4. Slide the cartridge door assembly (callout 1) in the direction the arrow indicates and remove it.

Figure 1-2037 Remove the door

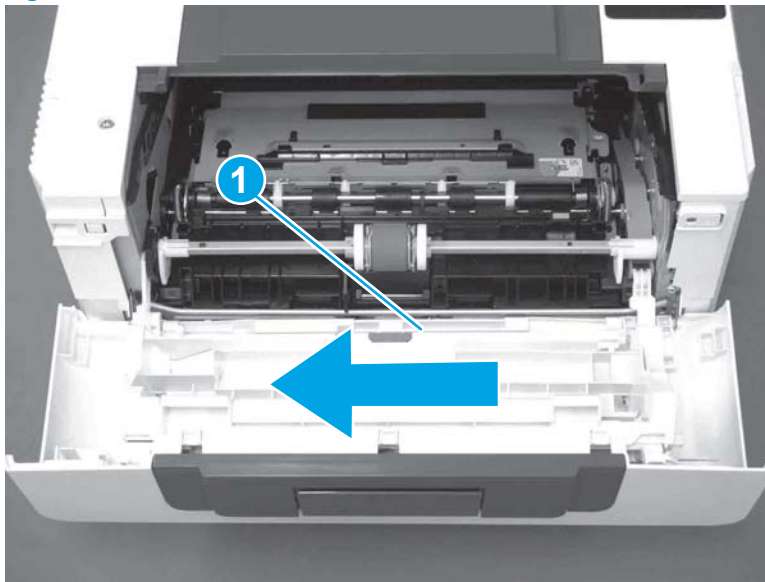

5. Remove the link (callout 1) from the cartridge door assembly (callout 2).

Figure 1-2038 Release the left-side retainer arm

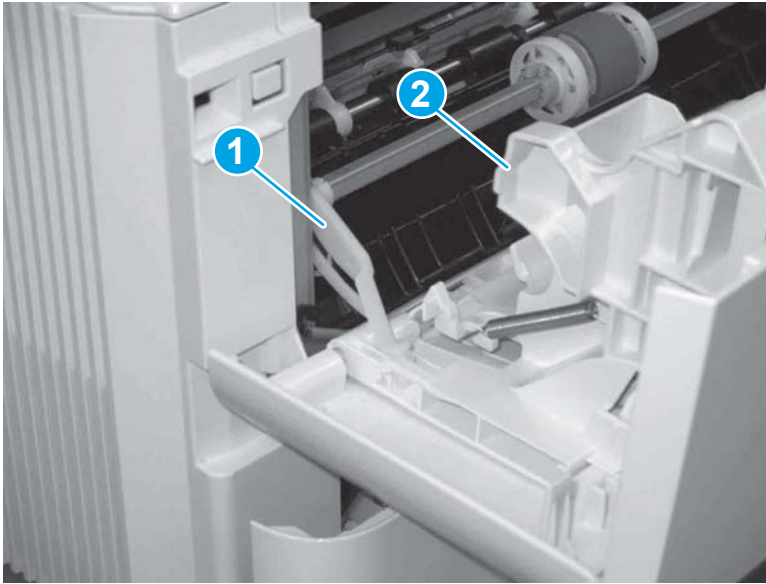

Step 3: Remove the left cover

1. Remove one screw (callout 1).

Figure 1-2039 Remove one screw

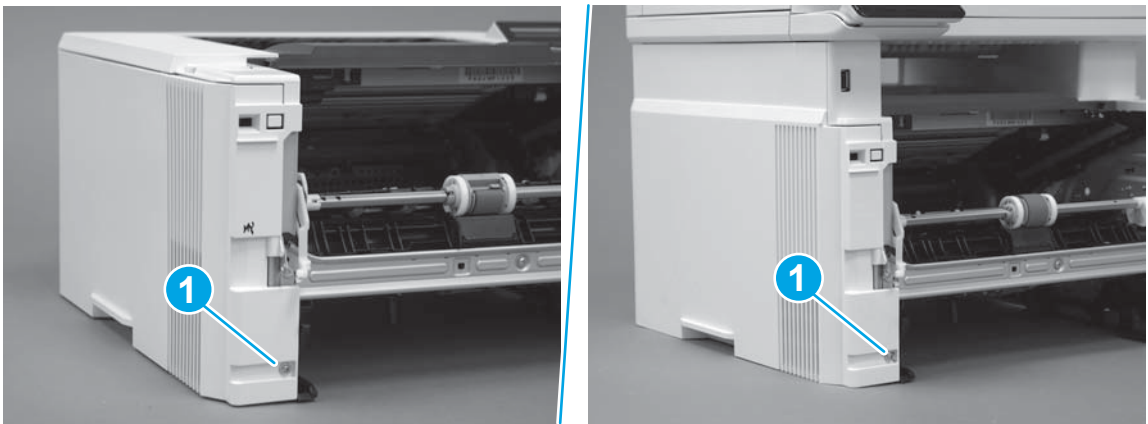

2. Open the rear door, release two bosses (callout 1), and then release three tabs (callout 2).

Figure 1-2040 Release two bosses and three tabs

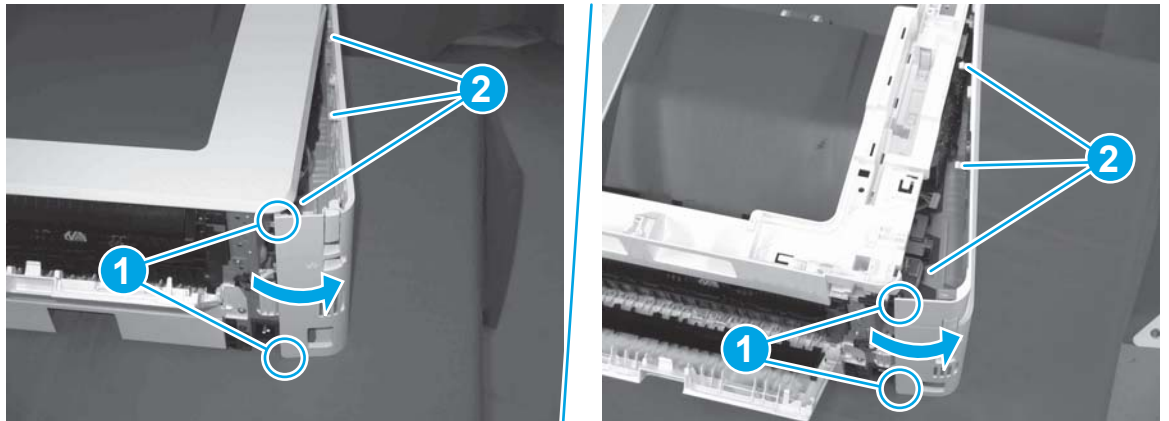

3. At the front of the printer, do one of the following:

- **M403/M402:** Release two bosses (callout 1), and then remove the cover (callout 2).
- **M427/M426:** Release one tab (callout 3), two bosses (callout 4), and then remove the cover (callout 5).

CAUTION: Be careful when releasing the upper bosses on the M427/M426 cover. One portion of the cover (callout 6) is fragile and is easily broken.

Figure 1-2041 Remove the cover

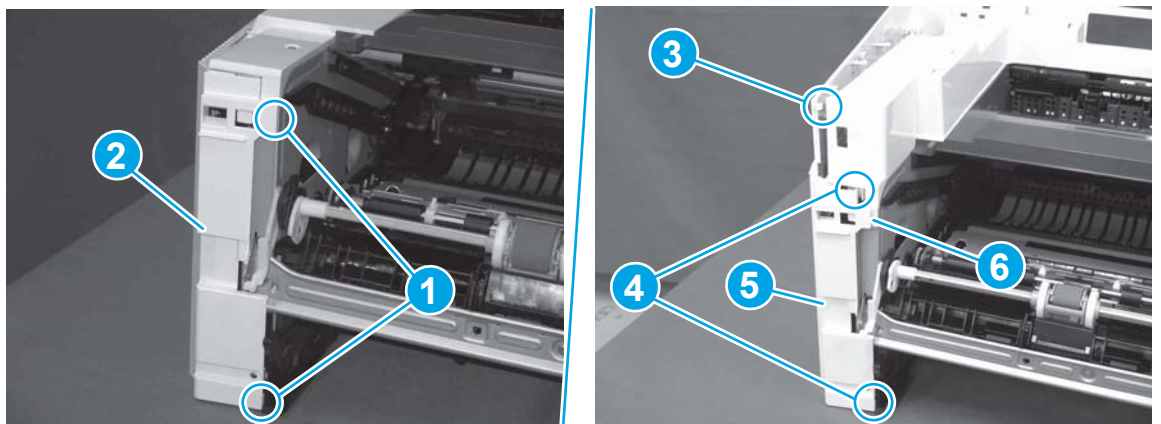

Step 4: Remove the right cover

1. Remove one screw (callout 1).

Figure 1-2042 Remove one screw

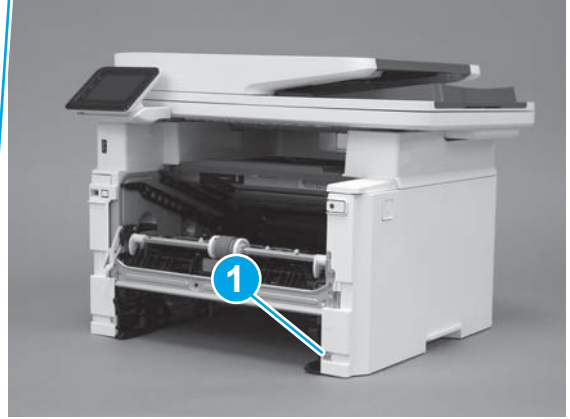
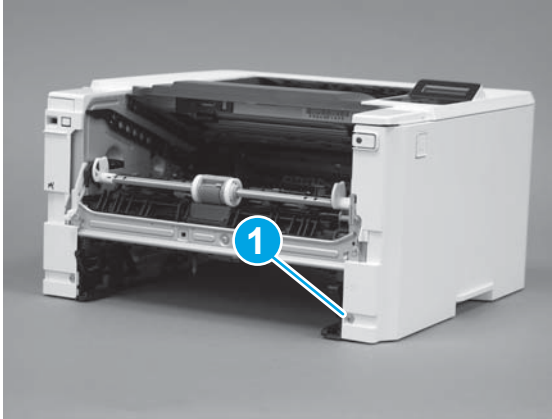

2. At the front of the printer, release two bosses (callout 1), and then release three tabs (callout 2).

Figure 1-2043 Release two bosses and three tabs

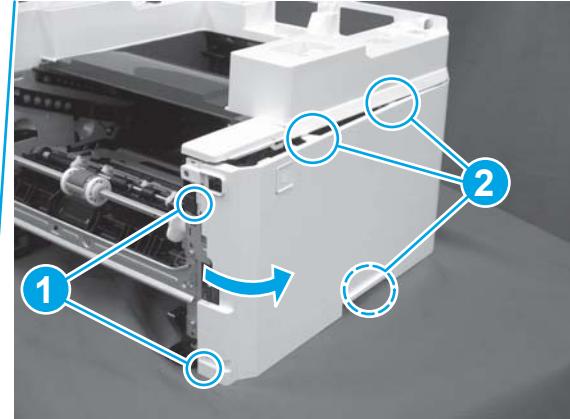
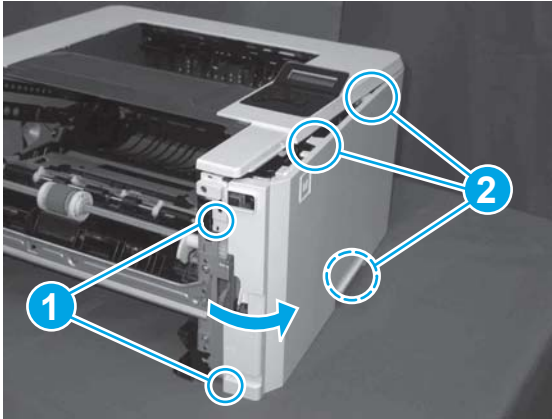

3. Open the rear door, release two bosses (callout 1), and then remove the cover (callout 2).

Figure 1-2044 Remove the cover

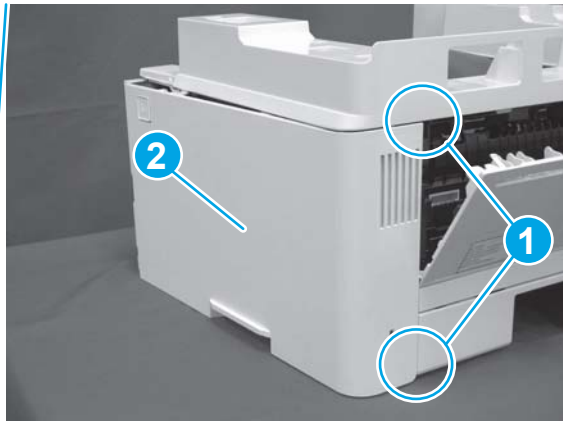
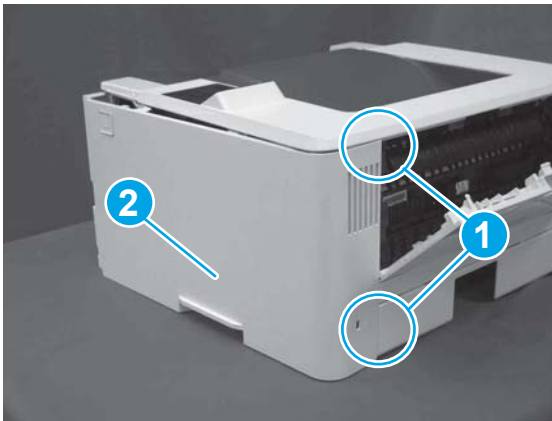

Step 5: Remove the integrated scanner assembly (M427/M246)



NOTE: The step is for the M427/M426 printer. For the M403/M402, skip this step and go to [Step 9: Remove the top cover \(M403/M402\) on page 1087](#).

 **NOTE:** M427/M426 models only. The integrated scanner assembly (ISA) includes the sub-scanner assembly (SSA) and the automatic document feeder (ADF).

1. Raise the ISA.

Figure 1-2045 Raise the ISA

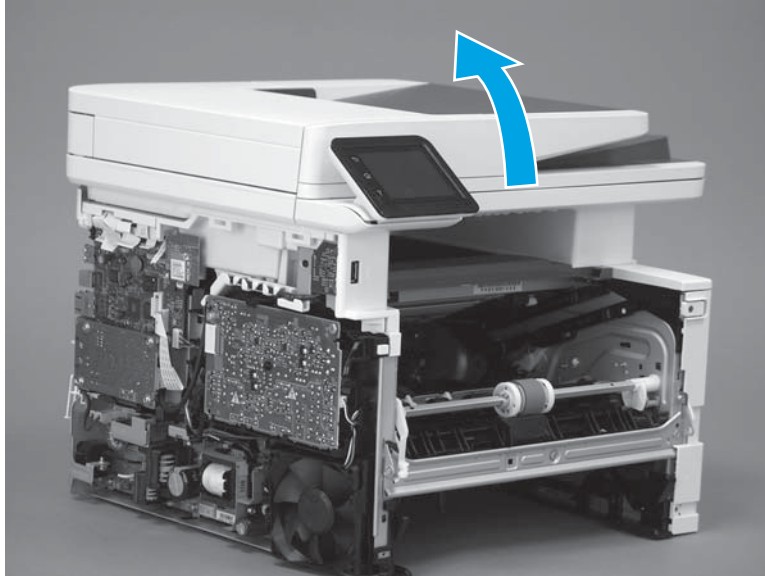

2. Release the ISA flat-flexible cable (FFC) cover (callout 1), and then remove it (callout 2).

Figure 1-2046 Remove the ISA FFC cover

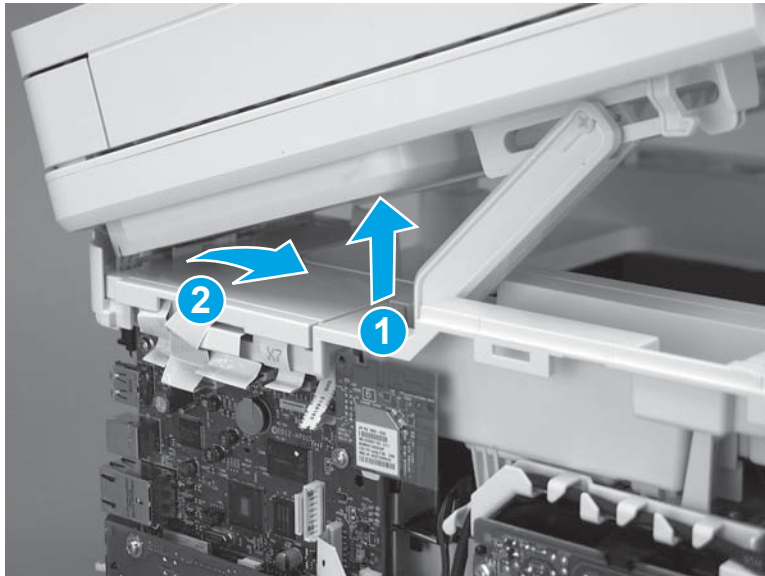

3. Disconnect three FFCs (callout 1), and then remove the ferrite (callout 2) from the holder.

⚠ CAUTION: The ferrite is not captive on the FFC. Do not lose the ferrite while handling the ISA.

Figure 1-2047 Disconnect three FFCs

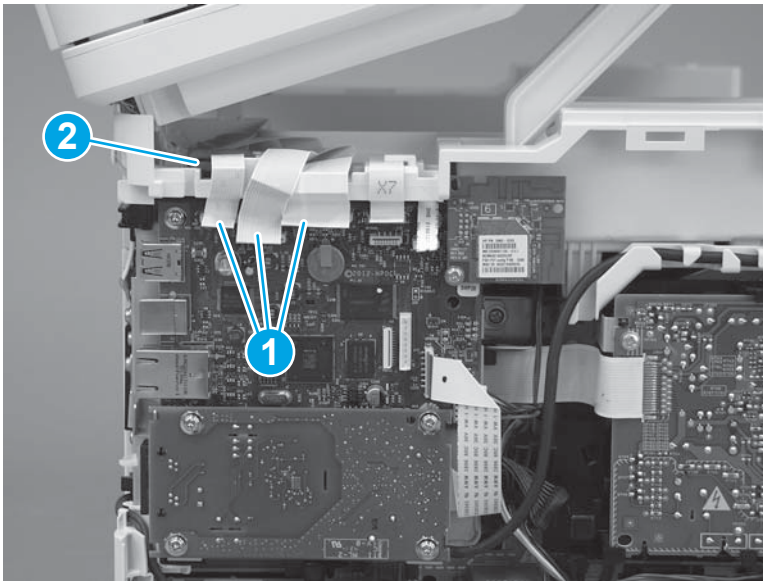

4. Remove one screw (callout 1).

Figure 1-2048 Remove one screw

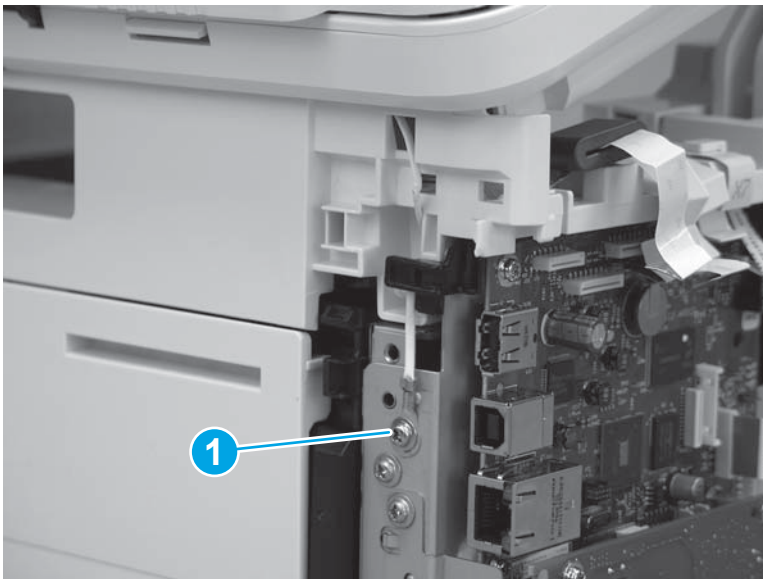

5. Pass the ground wire through the opening in the top cover.

Figure 1-2049 Pass the wire through the opening

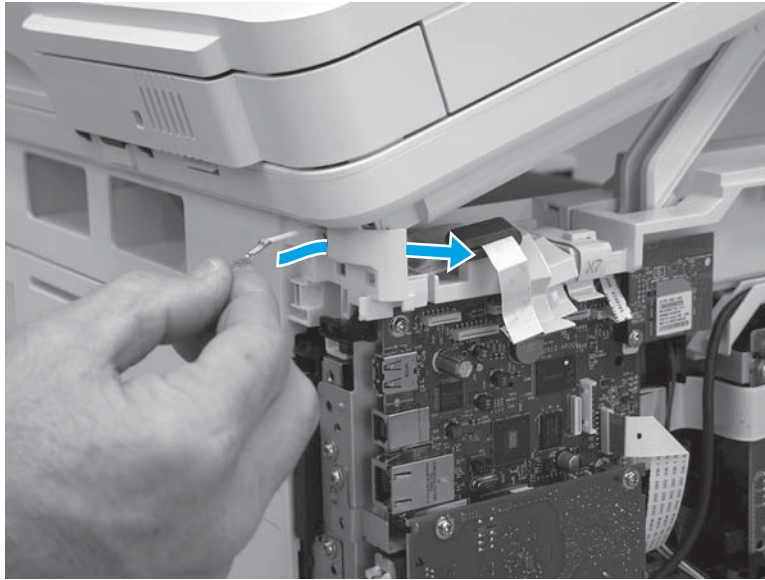

6. Release one tab (callout 1), and then rotate the ISA slider pin (callout 2) towards the front of the printer to release it.

Figure 1-2050 Release one tab and rotate the slider pin

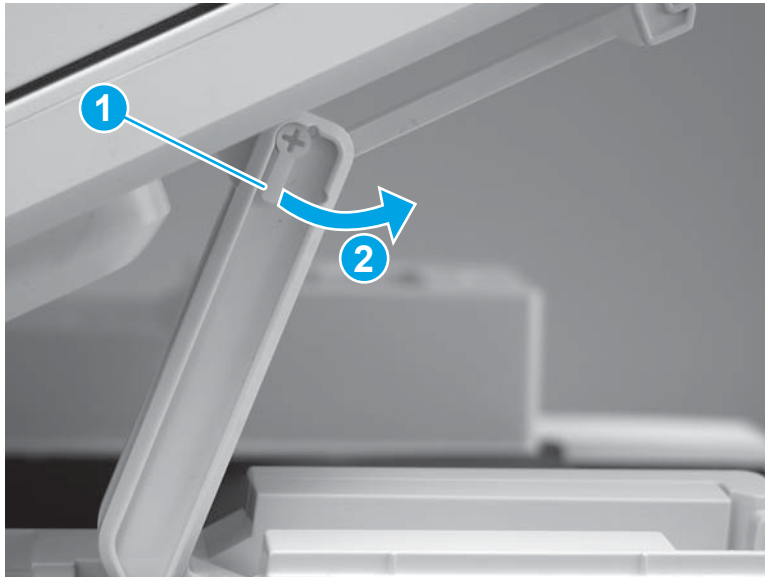

7. Remove the slider pin.

Figure 1-2051 Remove the slider pin

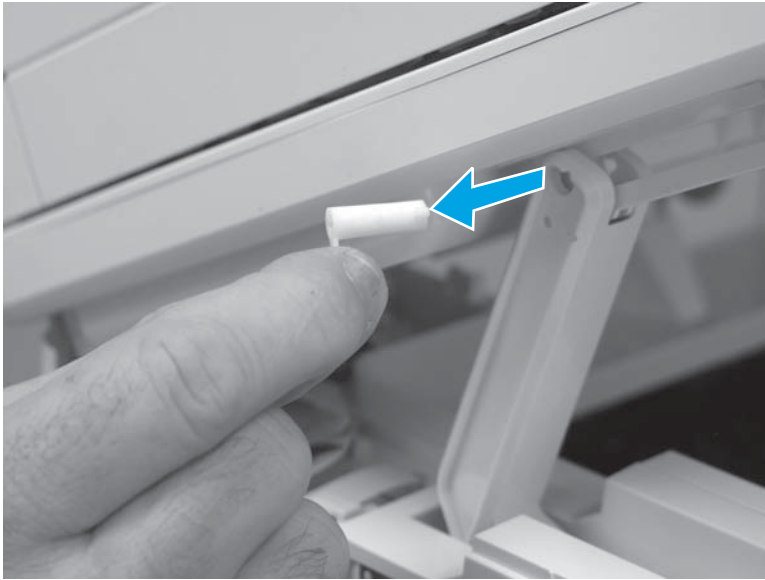

8. Rotate the ISA towards the rear of the printer until it stops.

Figure 1-2052 Rotate the ISA towards the rear of the printer



- Slide the ISA as shown to release it.

Figure 1-2053 Release the ISA

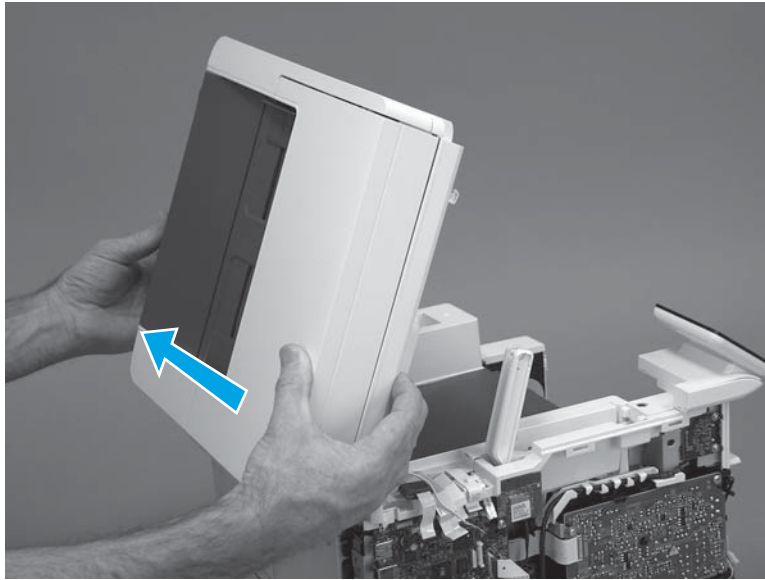

- Remove the ISA.

Figure 1-2054 Remove the ISA

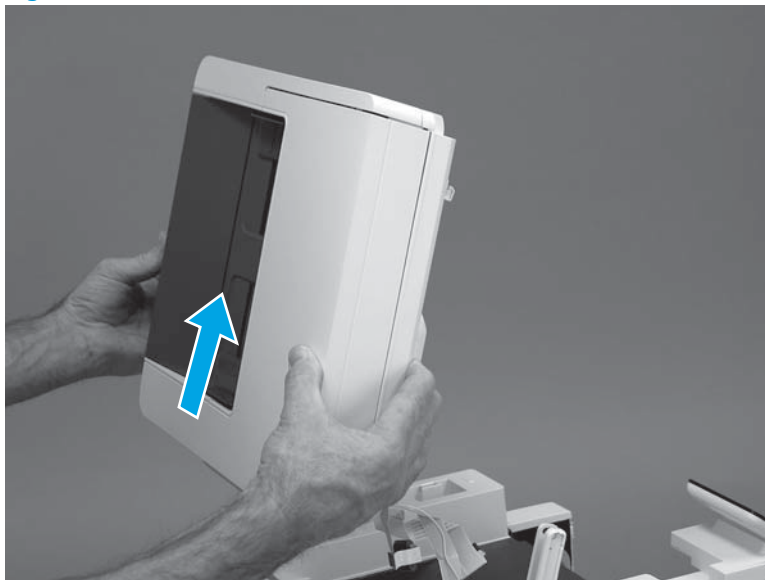

Step 6: Remove the control panel (M427/M426)

 **NOTE:** The step is for the M427/M426 printer. For the M403/M402, skip this step and go to [Step 9: Remove the top cover \(M403/M402\) on page 1087](#).

- Disconnect one FFC (callout 1; J114), and then release the FFC from the retainer (callout 2).

Figure 1-2055 Disconnect one connector

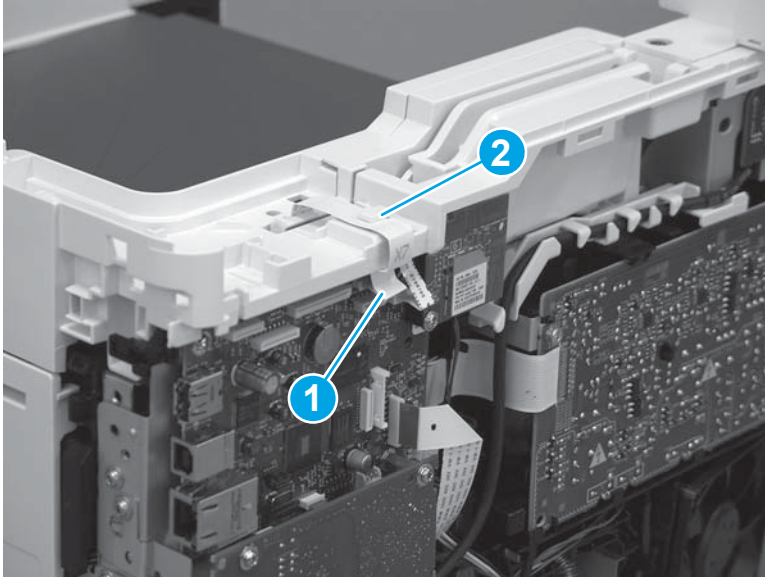

2. Remove one screw (callout 1).

Figure 1-2056 Remove one screw

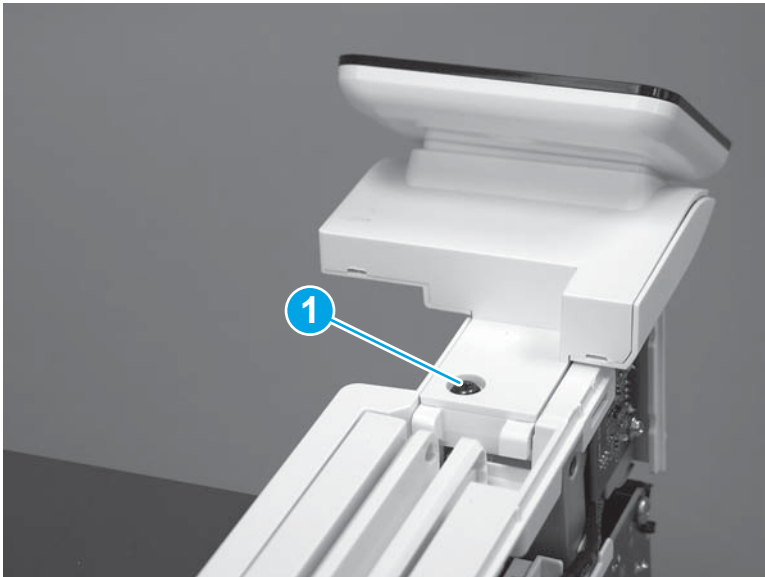

3. Use a small flat-blade screwdriver to release two tabs (callout 1) on the control-panel cable cover.

Figure 1-2057 Release two tabs

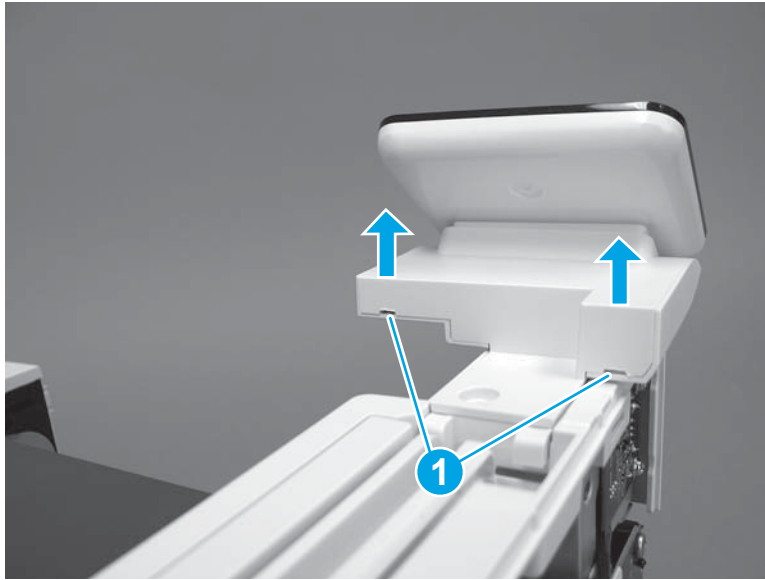

4. Remove the control-panel cable cover.

Figure 1-2058 Remove the cover

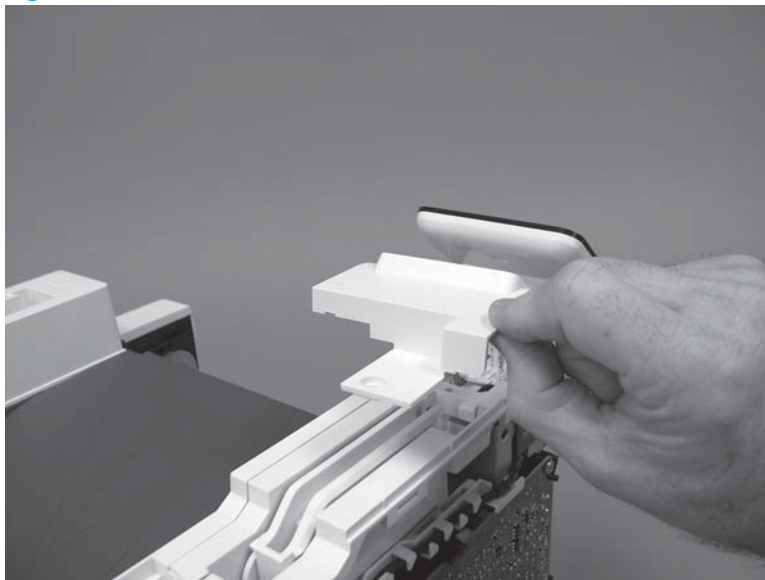

5. Remove one grounding screw (callout 1), and then move the ground cable (callout 2) out of the way.

Figure 1-2059 Remove one screw

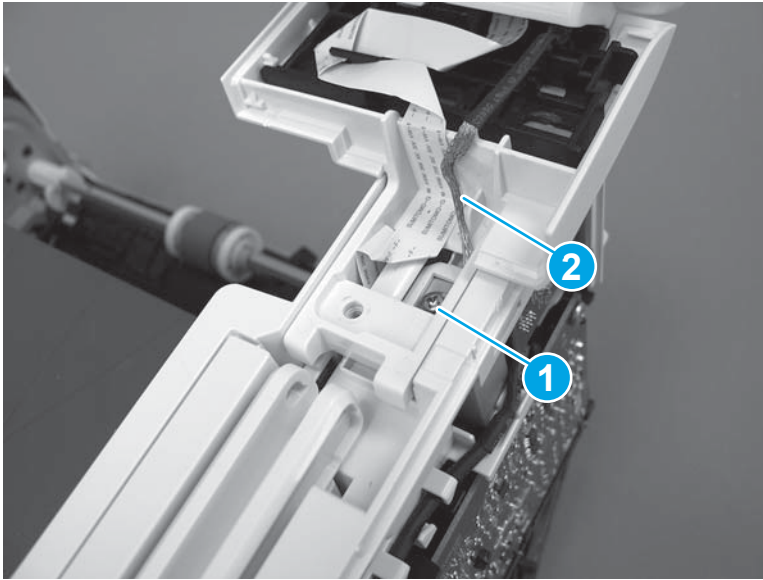

6. Move the FFC out of the way, and then remove two screws (callout 1).

Figure 1-2060 Remove two screws

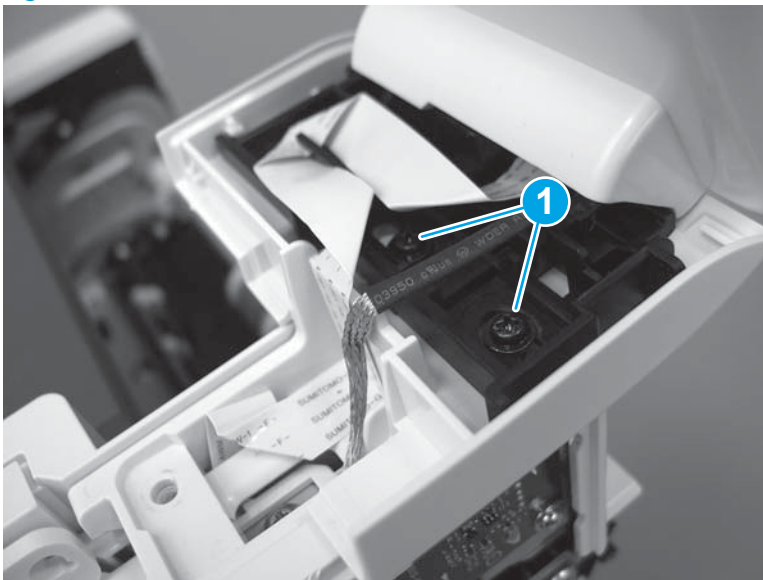

7. Slightly lift up the control-panel assembly to separate it from the top cover.

CAUTION: The control panel assembly is still connected to the printer by the FFC. Do not attempt to completely remove the assembly.

Figure 1-2061 Lift up the control-panel assembly

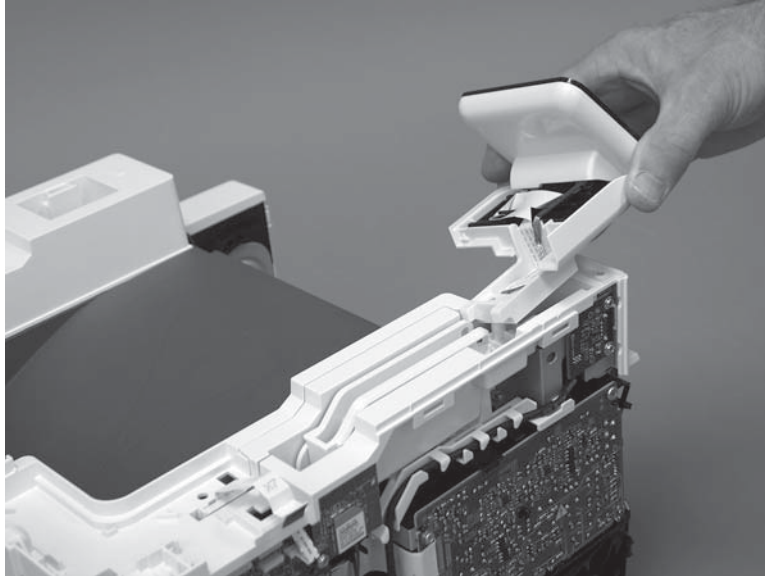

8. Lift up the control-panel FFC cover to remove the control-panel assembly.

Figure 1-2062 Remove the control-panel assembly

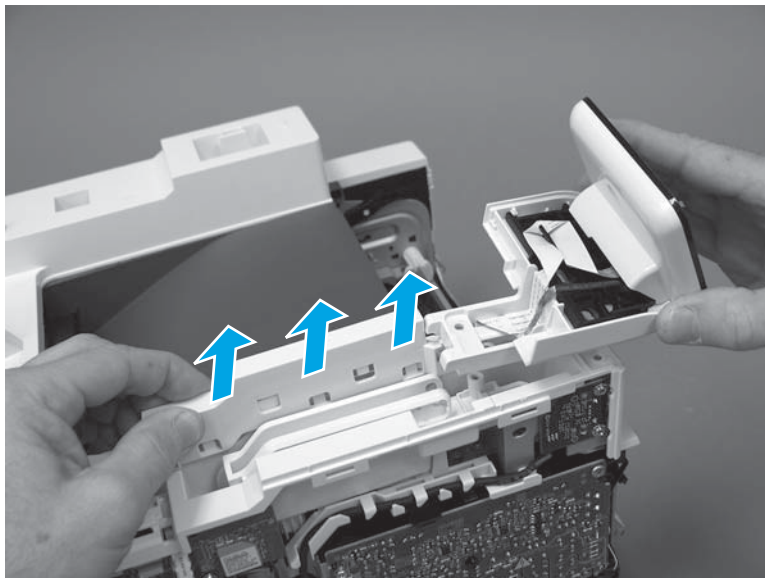

Step 7: Remove the top cover (M427/M426)

NOTE: The step is for the M427/M426 printer. For the M403/M402, skip this step and go to [Step 9: Remove the top cover \(M403/M402\) on page 1087](#).

1. Release the USB cable (callout 1) from the cable guide.

Figure 1-2063 Remove the USB cable

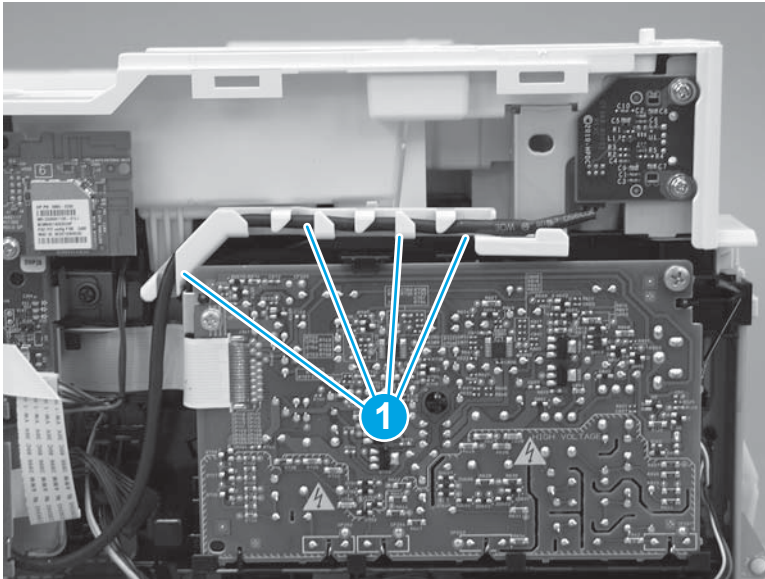

2. Remove five screws (callout 1), release four bosses (callout 2), and then remove the top cover (callout 3).

Figure 1-2064 Remove the cover

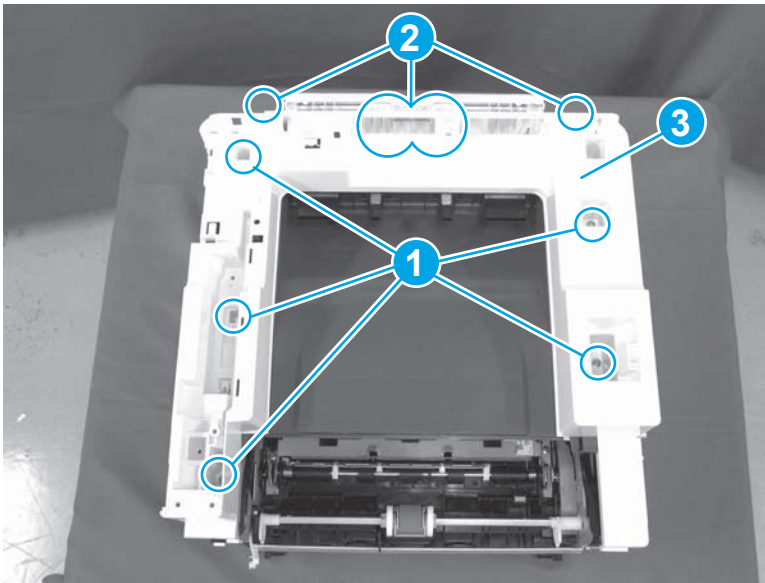

Step 8: Remove the NFC cover (M427/M426)



NOTE: The step is for the M427/M426 printer. For the M403/M402, skip this step and go to [Step 9: Remove the top cover \(M403/M402\) on page 1087](#).

- ▲ Carefully pull up on the NFC cover (callout 1) to remove it.



CAUTION: Do not damage the NFC PCA when removing the cover.

Figure 1-2065 Remove the cover

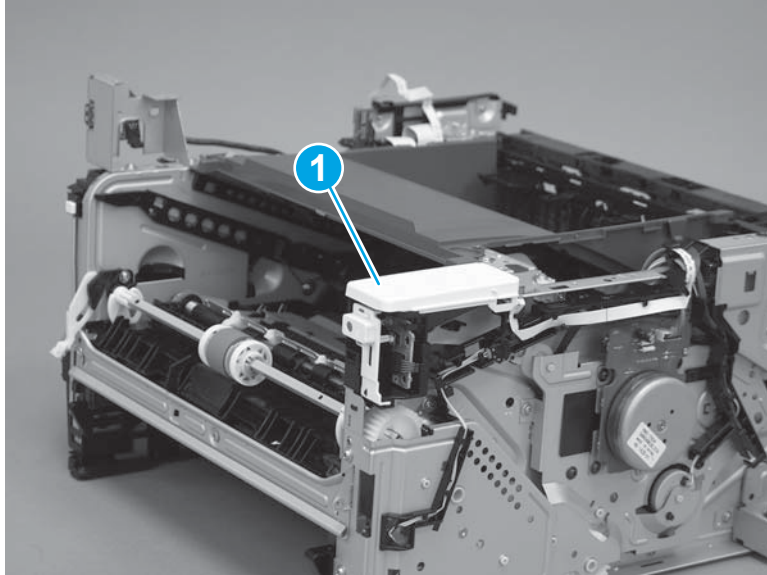

Step 9: Remove the top cover (M403/M402)

 **NOTE:** The step is for the M403/M402 printer. For the M427/M426, skip this step and go to [Step 10: Remove the NFC PCA on page 1088](#).

1. Remove one screw (callout 1).

Figure 1-2066 Remove one screw



2. At the right side of the printer, release the one boss (callout 1), and then release one tab (callout 2).

Figure 1-2067 Release one boss and one tab

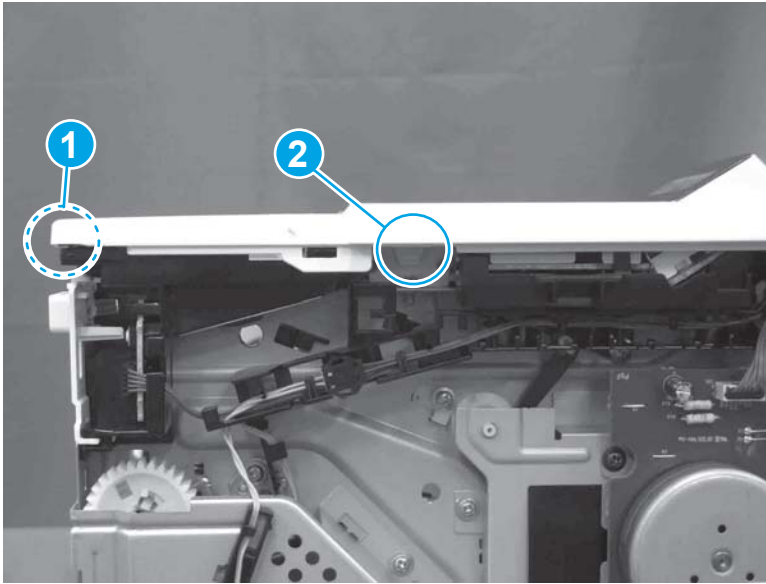

3. Release four tabs (callout 1), release four bosses (callout 2), and then remove the top cover (callout 3).

 **TIP:** Open the rear door to make releasing the bosses (callout 3) easier.

Figure 1-2068 Remove the cover



Step 10: Remove the NFC PCA

 **NOTE:** M427fdw/M426fdw/M402dw/M403dw models only.

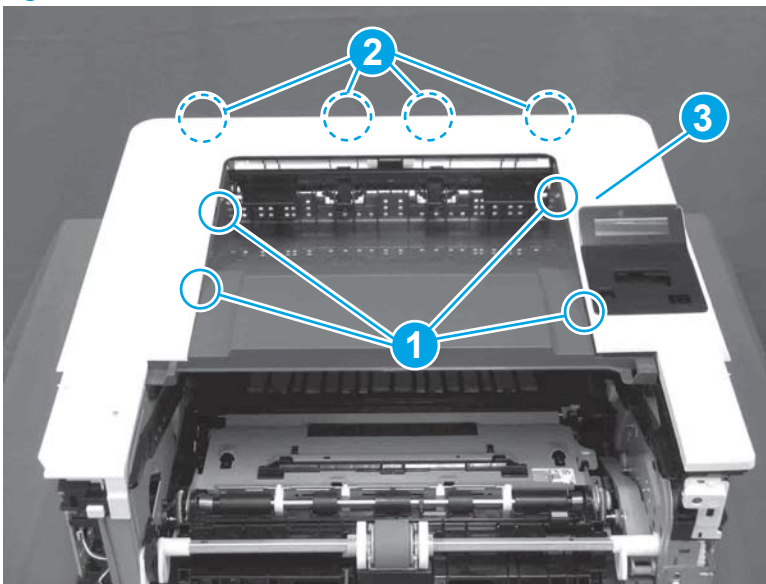
The M403 printer is shown in this procedure. However, the procedure is valid for the M427/M426/M402 printers.

1. Remove one screw (callout 1).

Figure 1-2069 Remove one screw

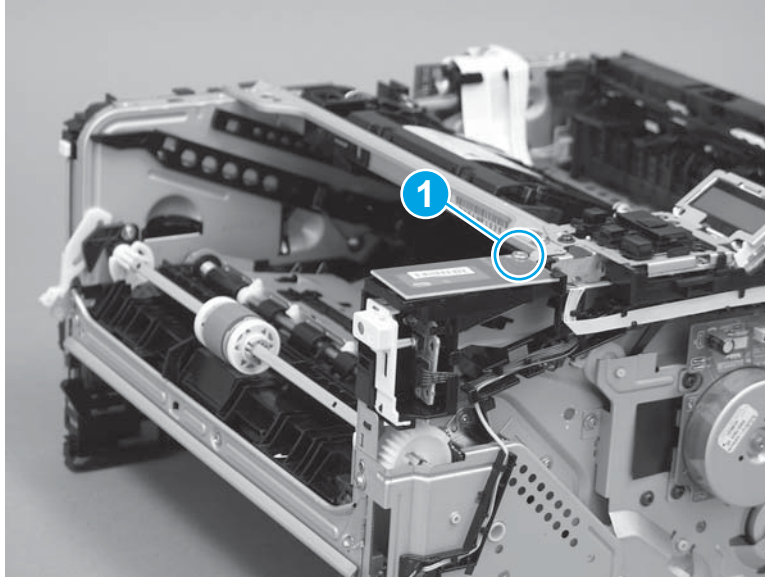

2. Turn the NFC PCA over to access the bottom side, disconnect one FFC (callout 1), and then remove the NFC PCA.

Figure 1-2070 Remove the NFC PCA

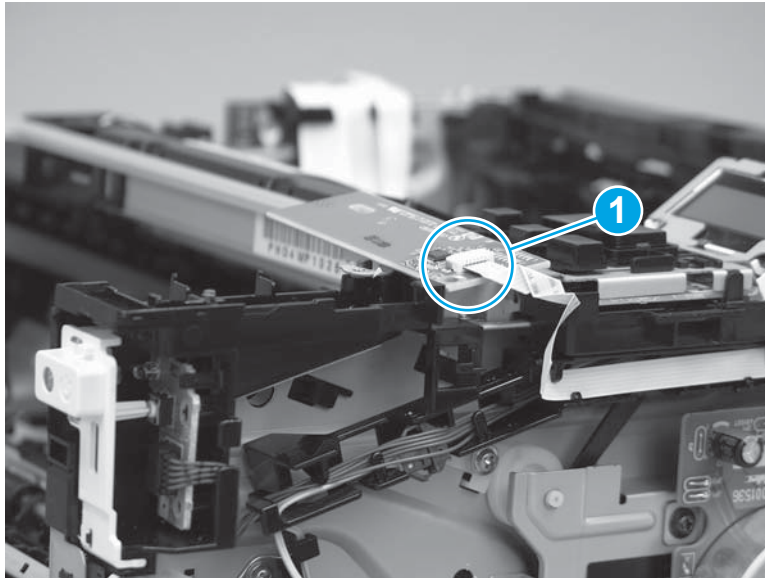

Step 11: Unpack the replacement assembly

Unpack the replacement part from the packaging.

<http://www8.hp.com/us/en/hp-information/environment/product-recycling.html>

 **NOTE:** HP recommends responsible disposal of the defective part.

Figure 1-2071 Recycle and unpack

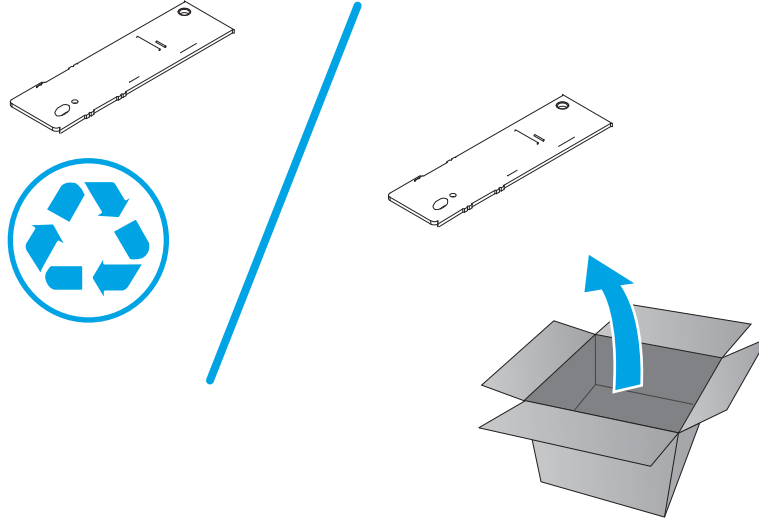

Step 12: Install the NFC PCA

 **NOTE:** M427fdw/M426fdw/M402dw/M403dw models only.

The M403dw printer is shown in this procedure. However, the procedure is valid for the M427/M426/M402 printers.

1. Connect one FFC (callout 1).

Figure 1-2072 Connect one FFC

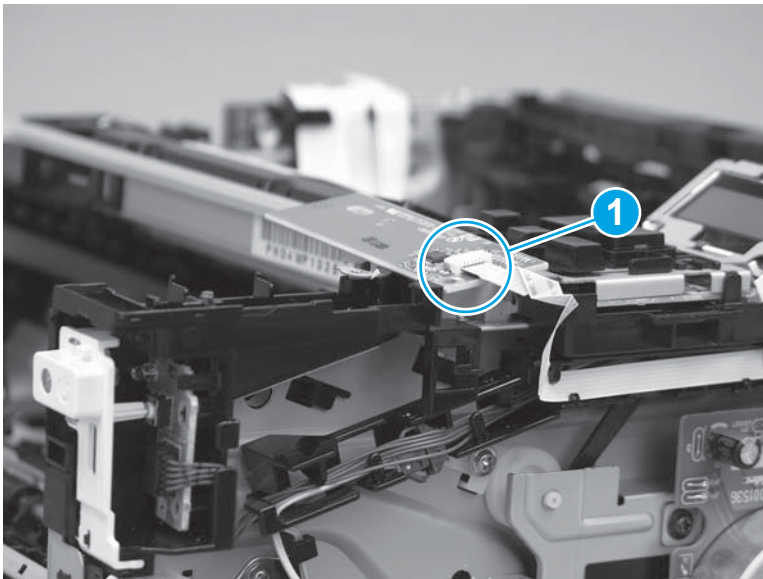

2. Position the NFC PCA on the holder.

CAUTION: Make sure that the NFC PCA is correctly positioned on the holder. One corner (callout 1) is under a tab on the holder, and the alignment pins on the holder fit in the hole and slot in the PCA (callout 2).

To avoid damage to the PCA, it must be installed flat on the holder **before** installing the mounting screw.

Figure 1-2073 Install the NFC PCA

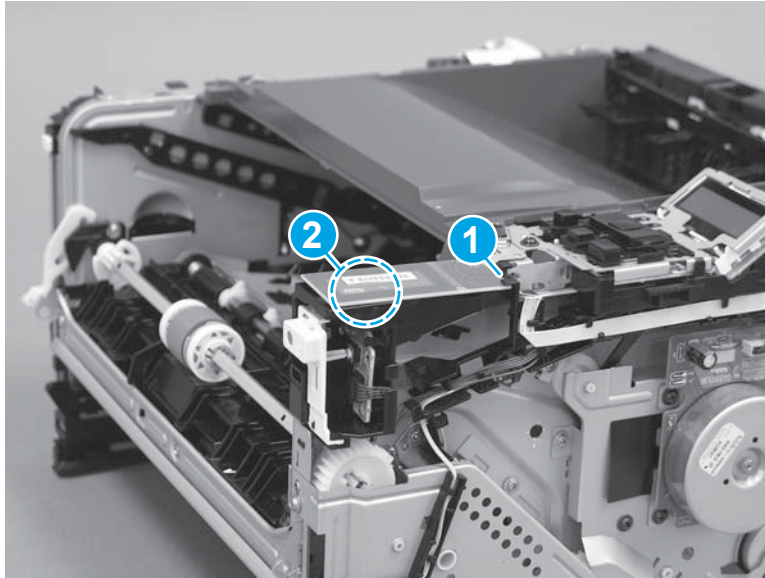

3. Install one screw (callout 1).

Figure 1-2074 Install one screw

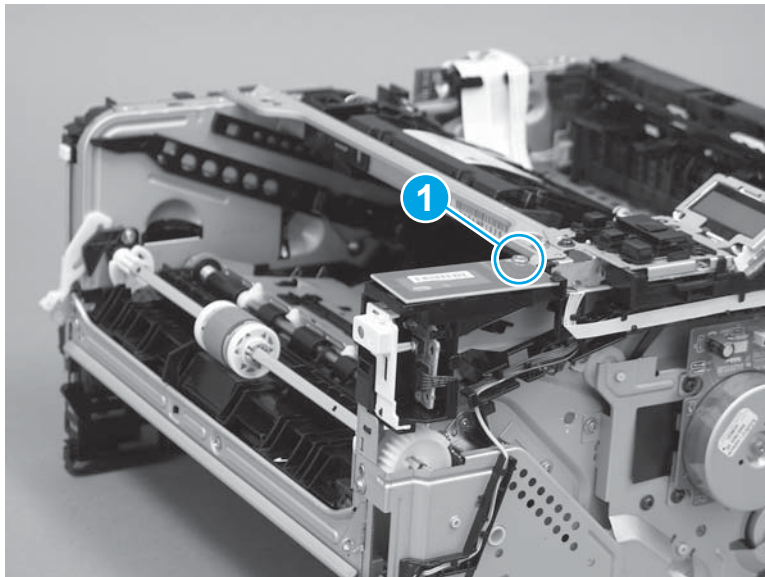

Step 13: Install the top cover (M403/M402)

NOTE: The step is for the M403/M402 printer. For the M427/M426, skip this step and go to [Step 18: Install the right cover on page 1105](#).

1. Position the rear edge of the cover on the printer.

Figure 1-2075 Install the cover

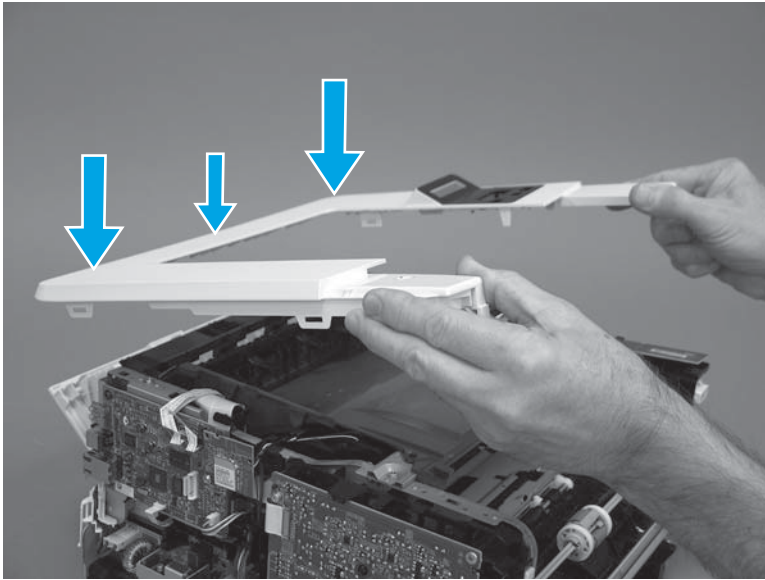

2. Engage four bosses (callout 1), rotate the front of the cover down (callout 2) and onto from the printer, and then engage four tabs (callout 3).

Figure 1-2076 Engage four bosses and tabs

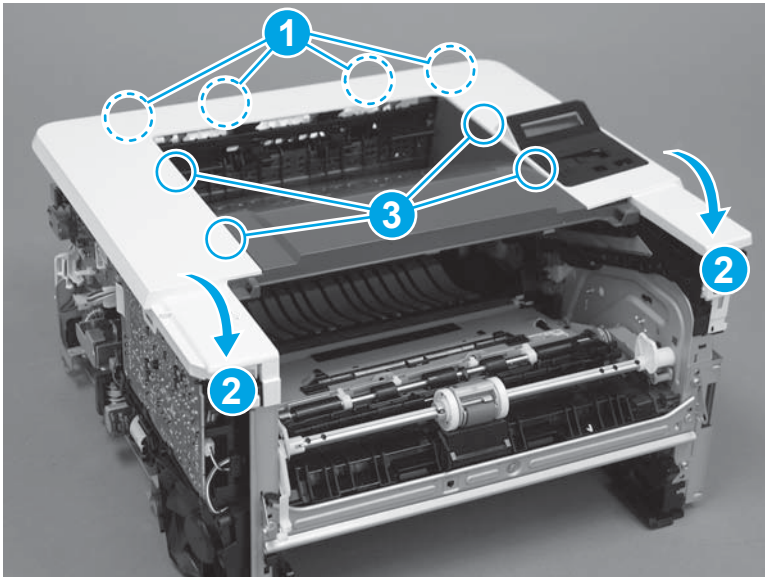

3. At the right side of the printer, engage the one boss and one tab (callout 1).

Figure 1-2077 Engage one boss and one tab

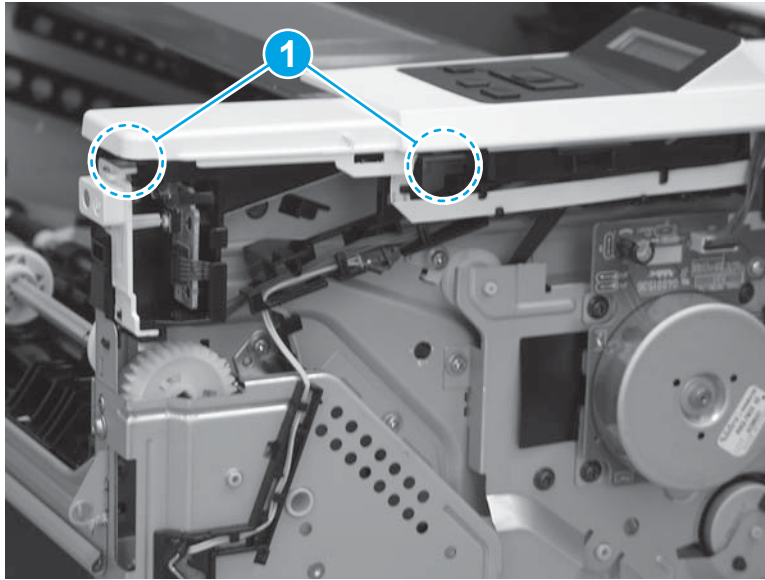

4. Install one screw (callout 1).

Figure 1-2078 Install one screw



Step 14: Install the NFC cover (M427/M426)

 **NOTE:** The step is for the (M427/M426) printer. For the M403/M402, skip this step and go to [Step 18: Install the right cover on page 1105](#).

- ▲ Carefully install the NFC cover on the printer.

 **CAUTION:** Do not damage the NFC PCA when installing the cover.

Figure 1-2079 Remove the cover

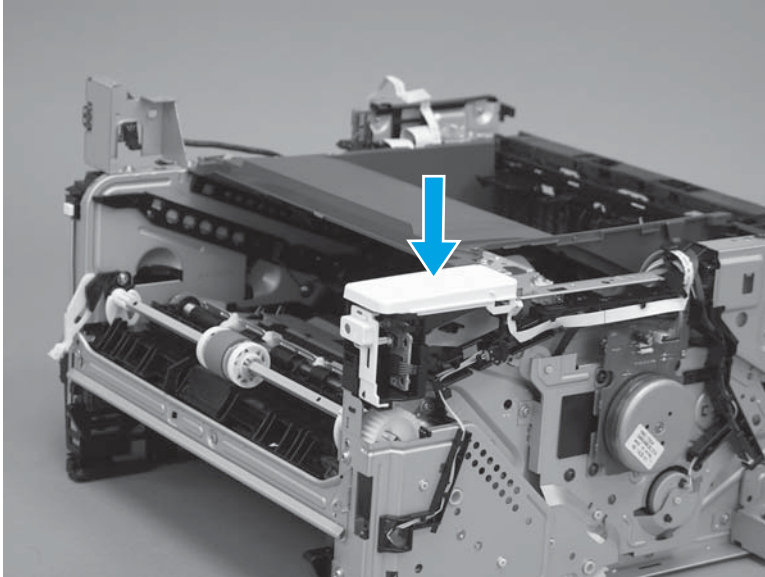

Step 15: Install the top cover (M427/M426)

 **NOTE:** The step is for the M427/M426 printer. For the M403/M402, skip this step and go to [Step 18: Install the right cover on page 1105](#).

1. Position the rear edge of the top cover on the printer.

Figure 1-2080 Install the cover

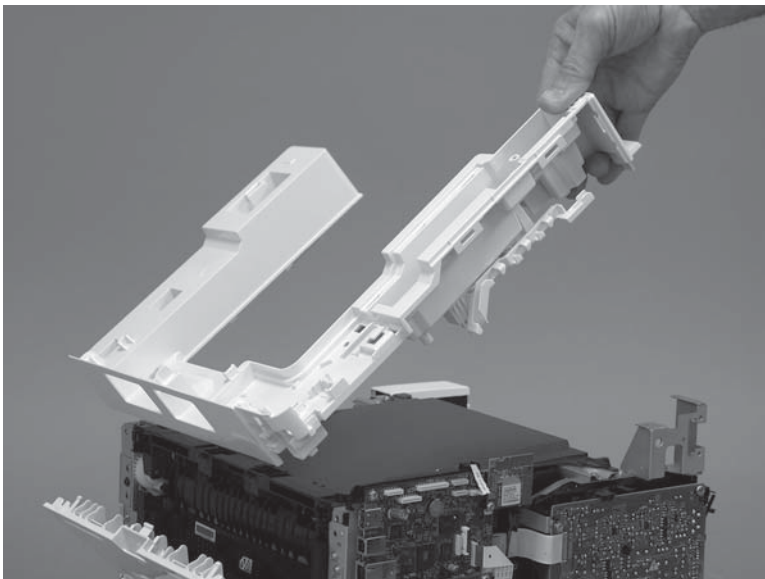

2. Engage four bosses (callout 1).

Figure 1-2081 Engage four bosses

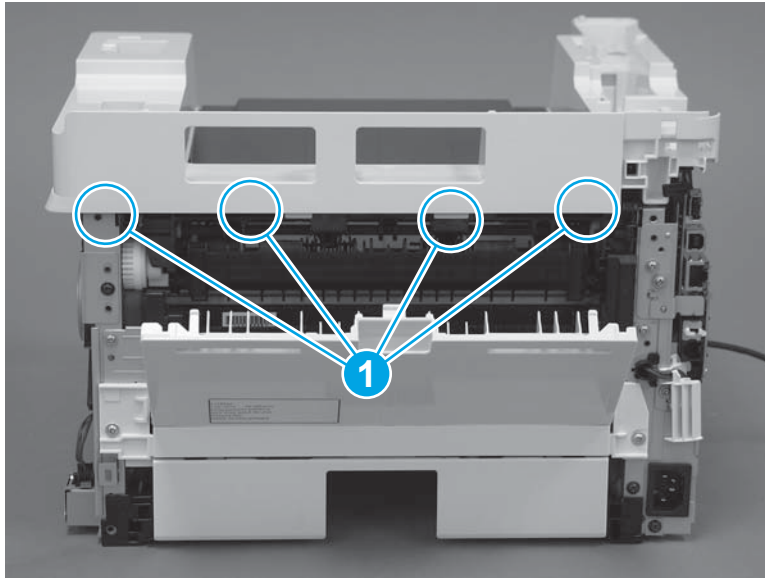

3. Rotate the front edge of the cover down.

Figure 1-2082 Rotate the front edge of the cover down

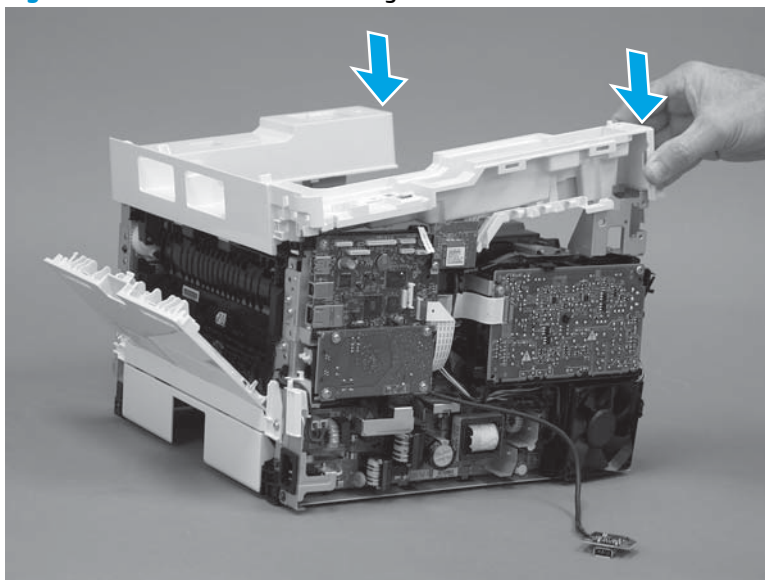

4. Install the USB cable (callout 1) in the guide.

Figure 1-2083 Install the USB PCA

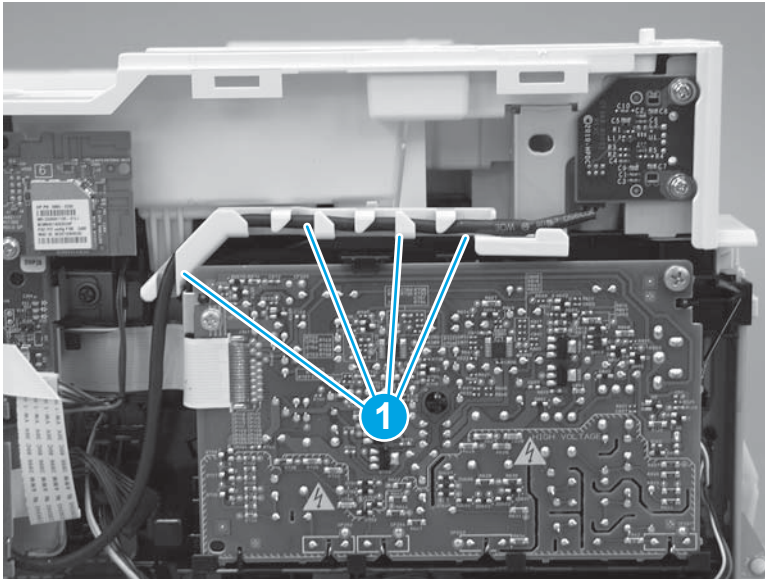

5. Install five screws (callout 1).

Figure 1-2084 Install five screws

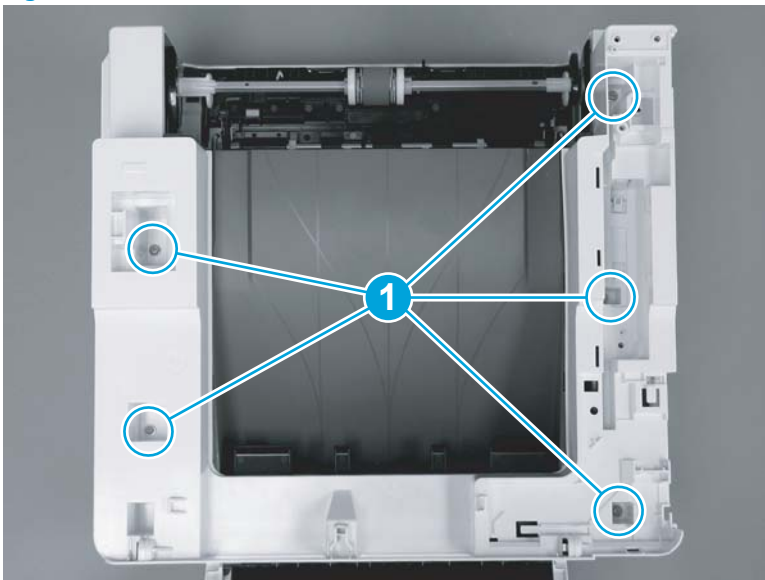

Step 16: Install the control panel (M427/M426)

 **NOTE:** The step is for the M427/M426 printer. For the M403/M402, skip this step and go to [Step 18: Install the right cover on page 1105](#).

1. Slide the control-panel FFC cover into the slot in the top cover (next to the document feeder support arm) to install it.

Figure 1-2085 Install the control-panel FFC cover

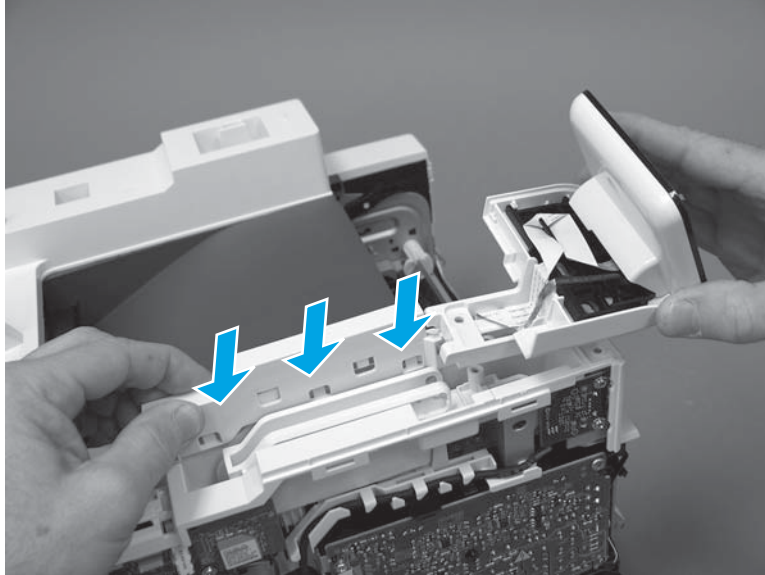

2. Install the control-panel assembly on the top cover.

Figure 1-2086 Install the control-panel assembly

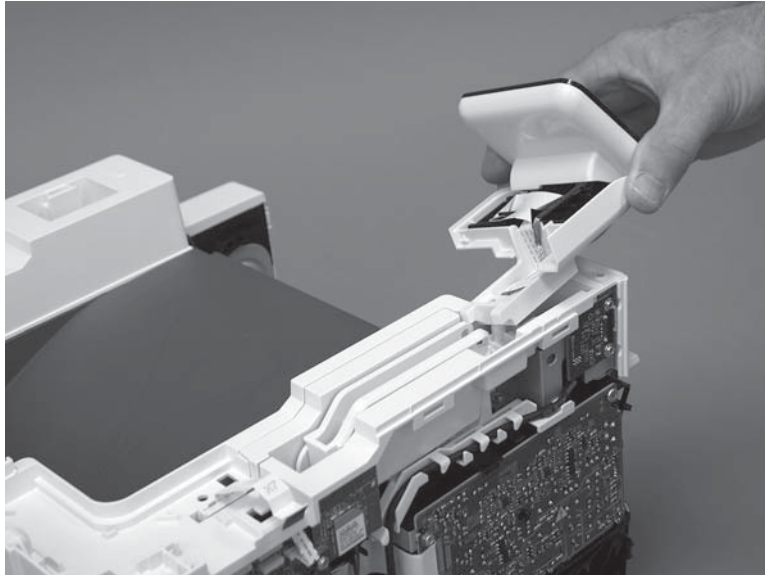

3. Move the FFC out of the way, and then install two screws (callout 1).

Figure 1-2087 Install two screws

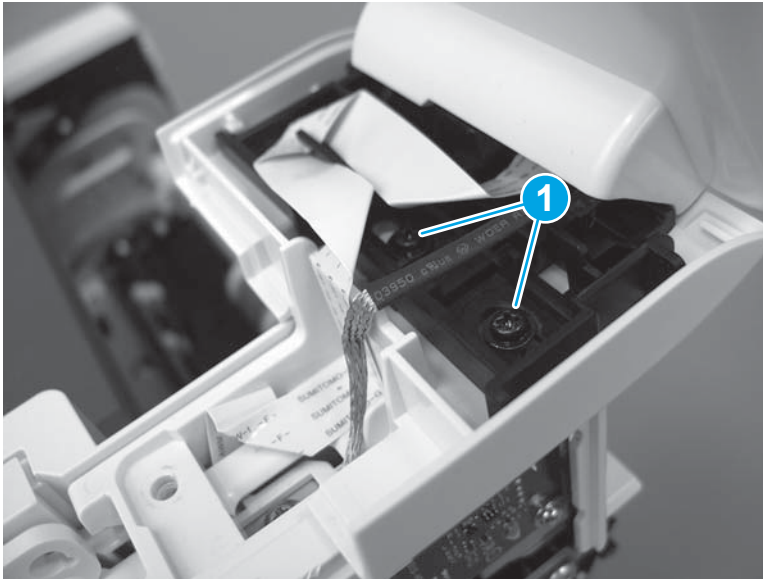

4. Install one grounding screw (callout 1), and then make sure that the ground cable (callout 2) is properly routed.

Figure 1-2088 Remove one screw

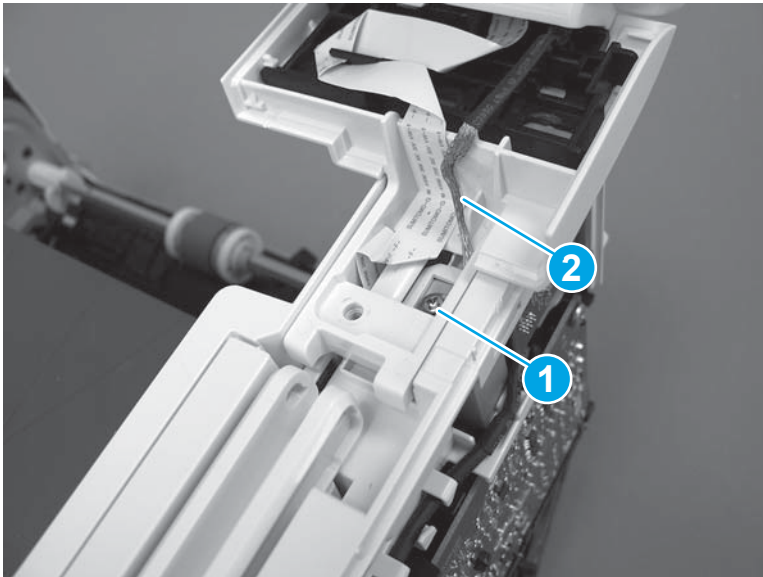

5. Install the control-panel cable cover.

Figure 1-2089 Install the cover

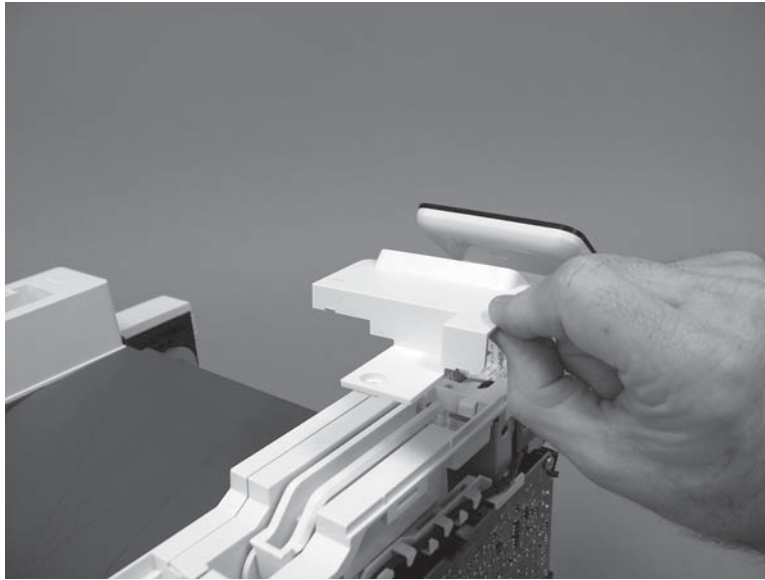

6. Make sure that the two tabs (callout 1) on the cover snap into place.

Figure 1-2090 Engage two tabs

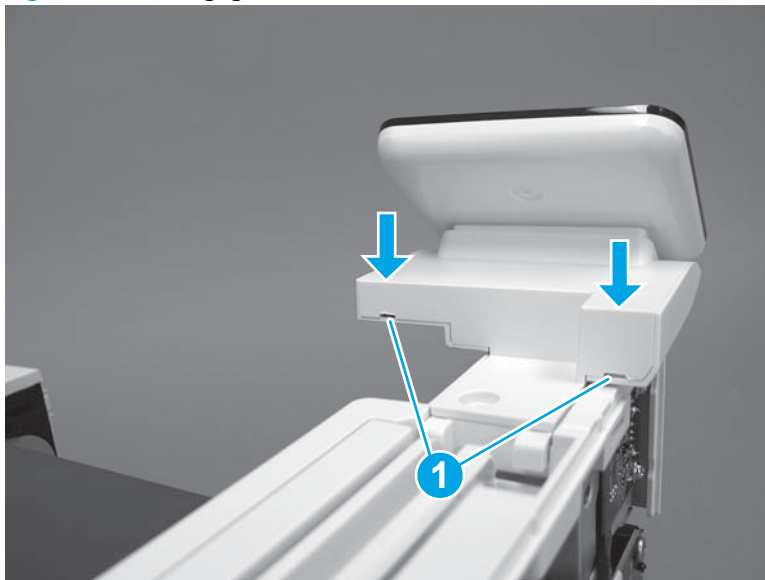

7. Install one screw (callout 1).

Figure 1-2091 Install one screw

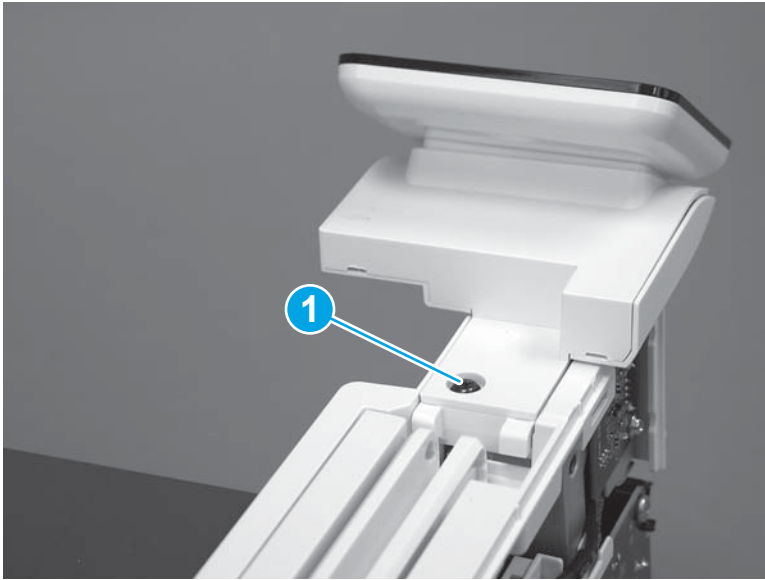

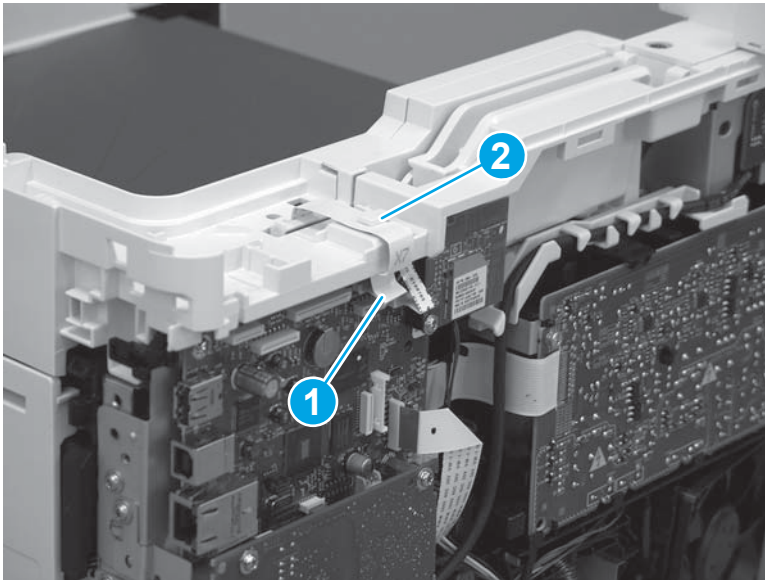

8. Install the FFC in the retainer (callout 1), and then connect one FFC (callout 1; J114).

Figure 1-2092 Connect one connector



Step 17: Install the integrated scanner assembly (M427/M246)

 **NOTE:** The step is for the M427/M426 printer. For the M403/M402, skip this step and go to [Step 18: Install the right cover on page 1105](#).

 **NOTE:** M427/M426 models only. The integrated scanner assembly (ISA) includes the sub-scanner assembly (SSA) and the automatic document feeder (ADF).

1. Position the ISA on the printer.

Figure 1-2093 Position the ISA on the printer

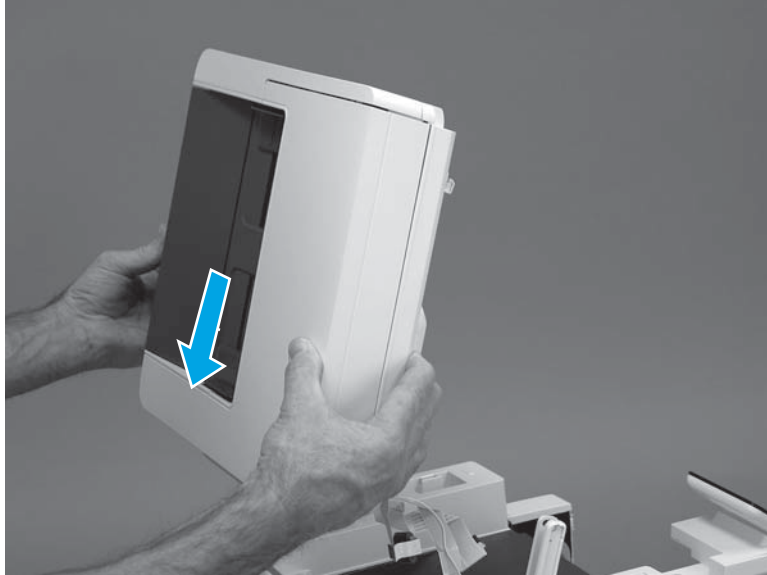

2. Engage the hinge pins on the ISA with the holders in the top cover (callouts 1/2), and then slide the ISA as shown to engage them

Figure 1-2094 Engage the hinge pins with the holders

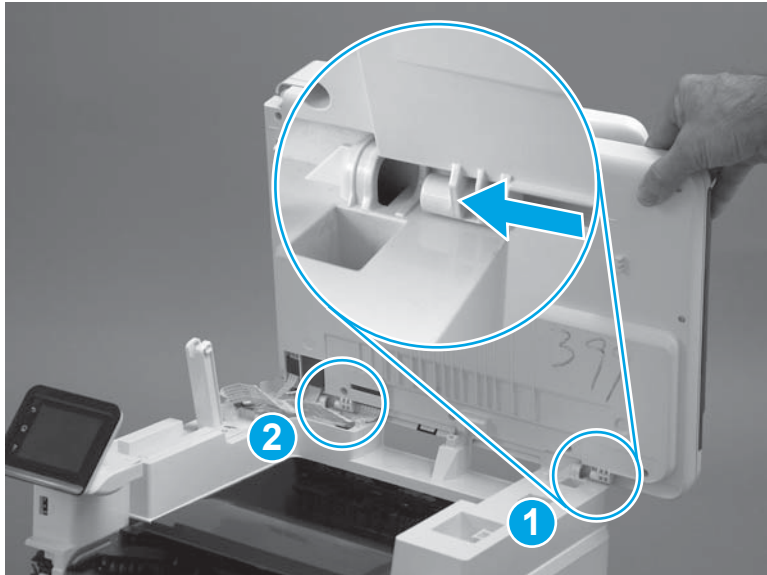

3. Rotate the ISA towards the front of the printer until it rests on the ISA lift assembly (callout 1).

Figure 1-2095 Rotate the ISA towards the front of the printer

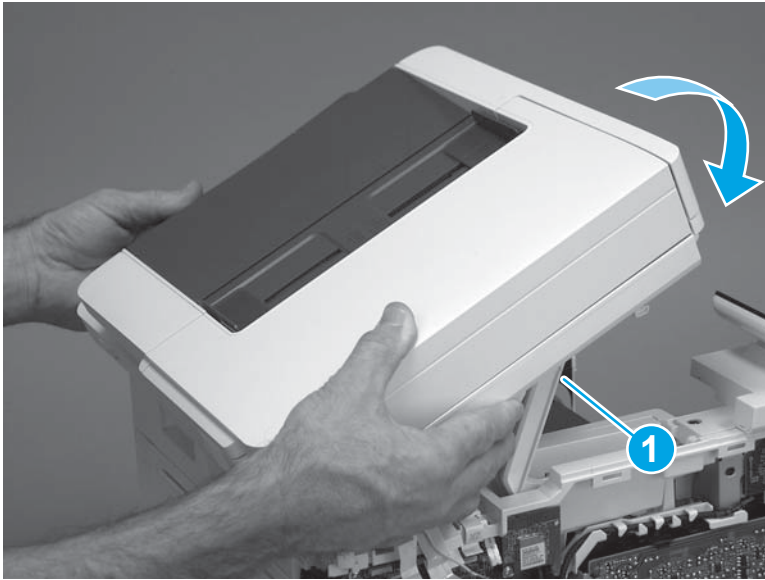

4. Pass the ground wire through the opening in the top cover.

Figure 1-2096 Pass the wire through the opening

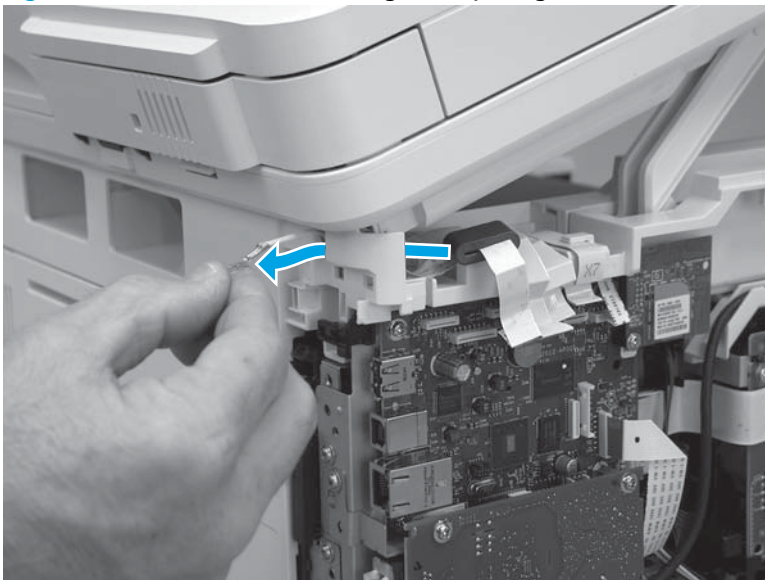

5. Install one screw (callout 1).

Figure 1-2097 Install one screw

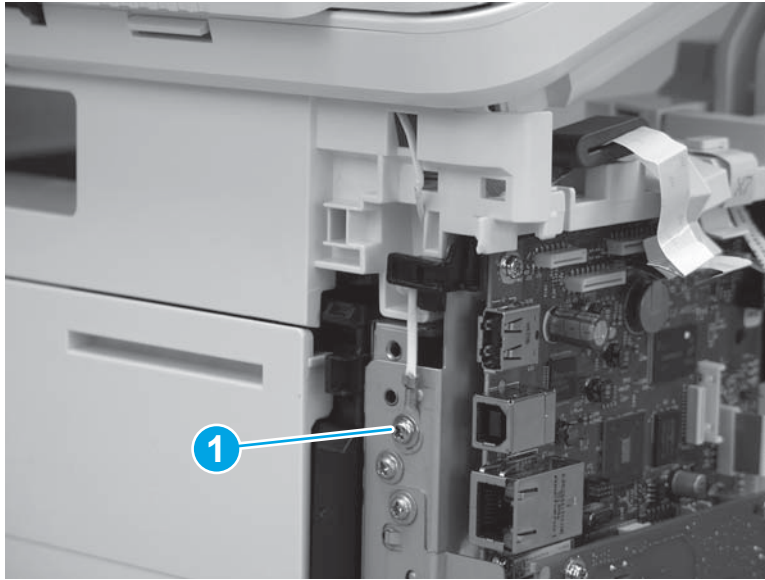

6. Install the ISA lift assembly slider pin.

 **Reinstallation tip:** Align the keyed portion of the locking pin with the slot and hole in the support arm.

Figure 1-2098 Install the slider pin



7. Rotate the slider pin (callout 1) towards the rear of the printer until the tab (callout 2) snap into place.

Figure 1-2099 Secure the slider pin

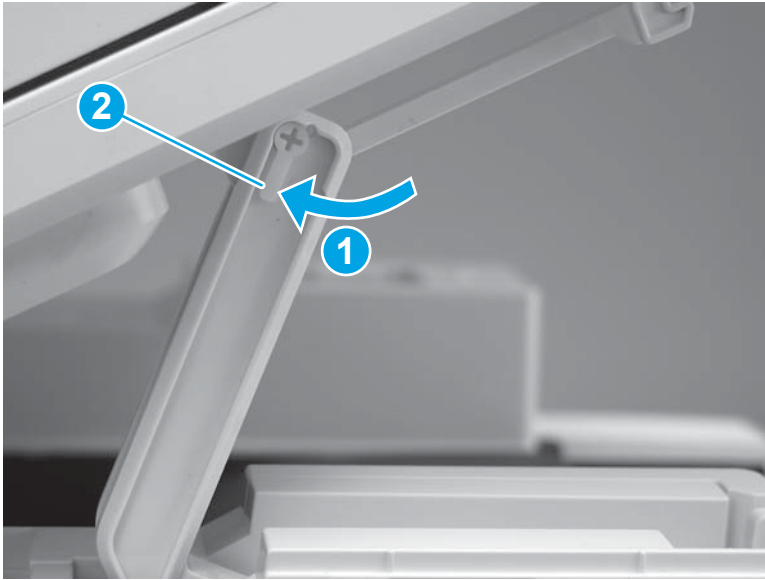

8. Install the ferrite (callout 1) in the holder, and then connect three FFCs (callout 2).

Figure 1-2100 Connect three FFCs

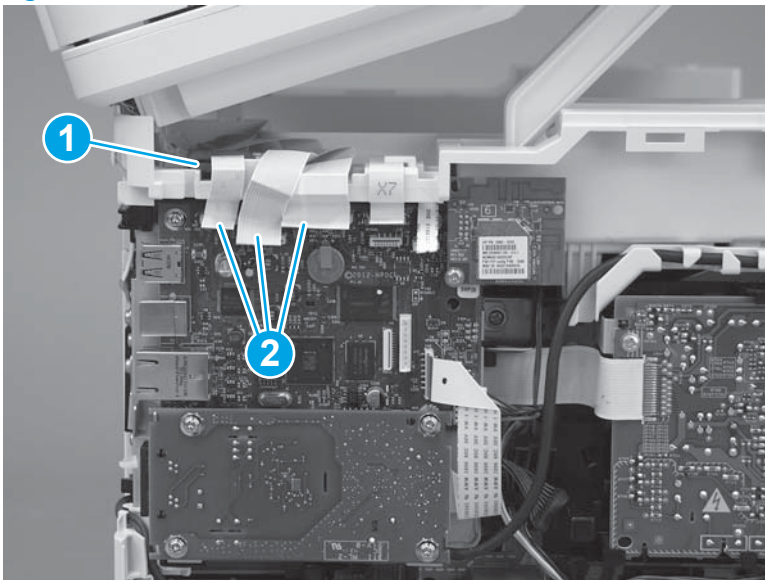

9. Position the rear edge of the ISA flat-flexible cable (FFC) cover on the printer (callout 1) , and then rotate it down (callout 2) until it snaps into place.

Figure 1-2101 Install the ISA FFC cover

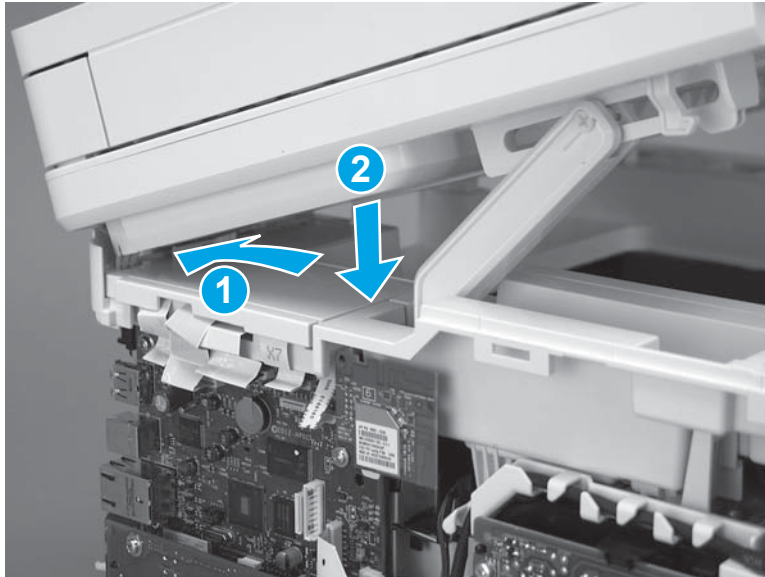

10. Lower the ISA.

Figure 1-2102 Lower the ISA

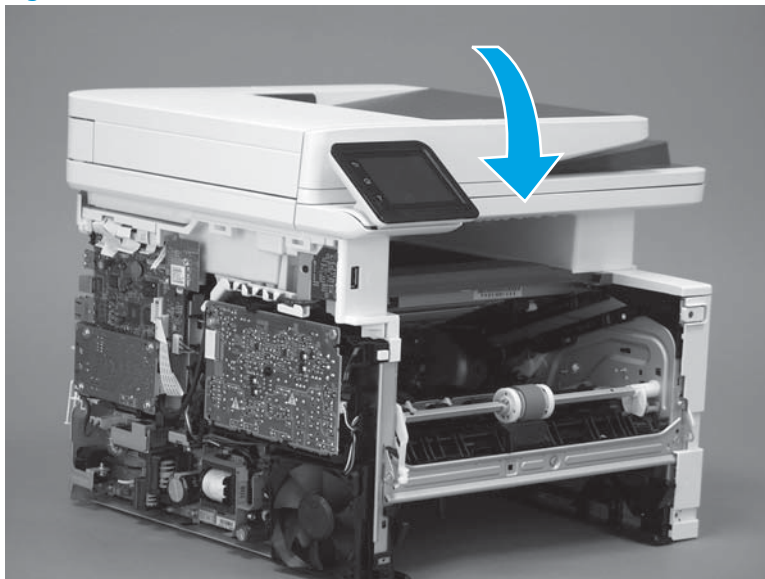

Step 18: Install the right cover

1. Position the cover (callout 1) on the printer, and then engage two bosses (callout 2).

Figure 1-2103 Install the cover

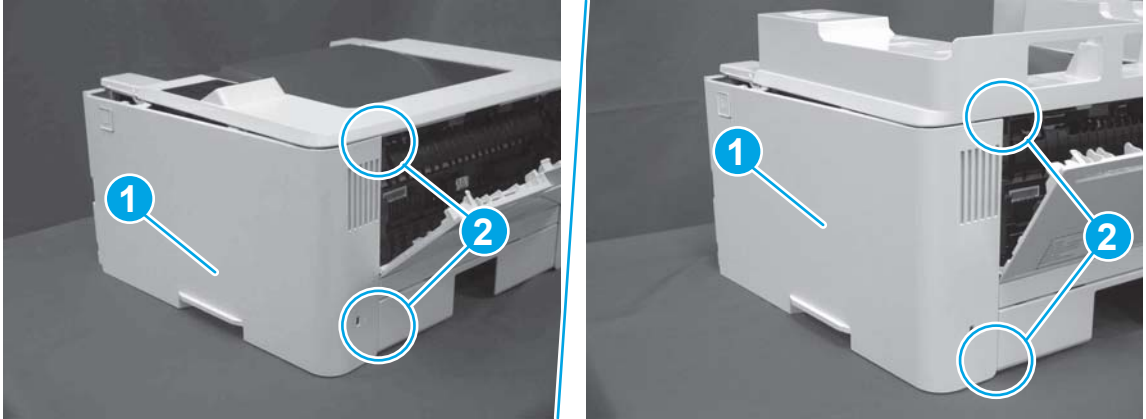

2. Rotate the front of the cover onto the printer (callout 1), engage three (callout 2) tabs, and then engage two bosses (callout 3).

Figure 1-2104 Engage two bosses and one tab

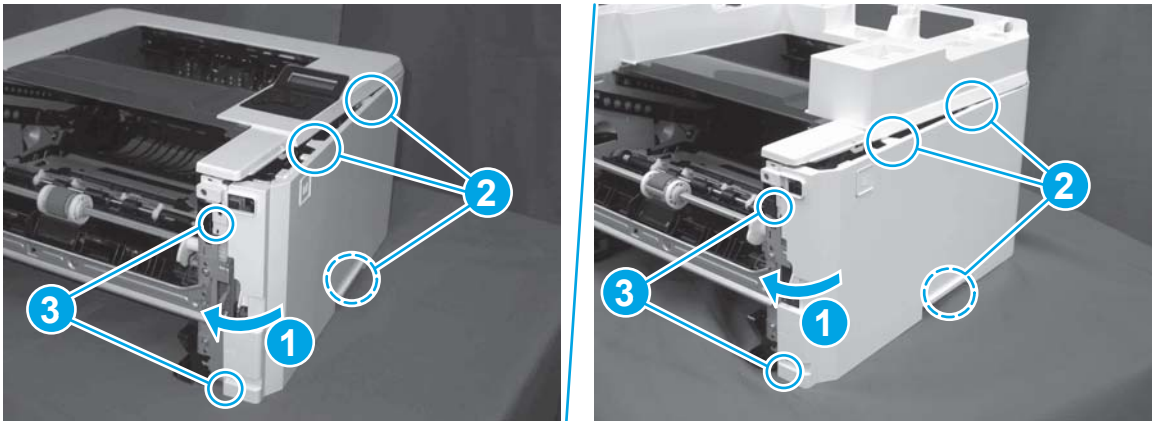

3. Make sure that the power switch (callout 1) and cartridge door assembly button (callout 2) correctly function.

 **NOTE:** Remove, and then reinstall the cover if the switch or button does not correctly function.

Figure 1-2105 Check the power switch and cartridge door assembly button



4. Install one screw (callout 1).

Figure 1-2106 Install one screw

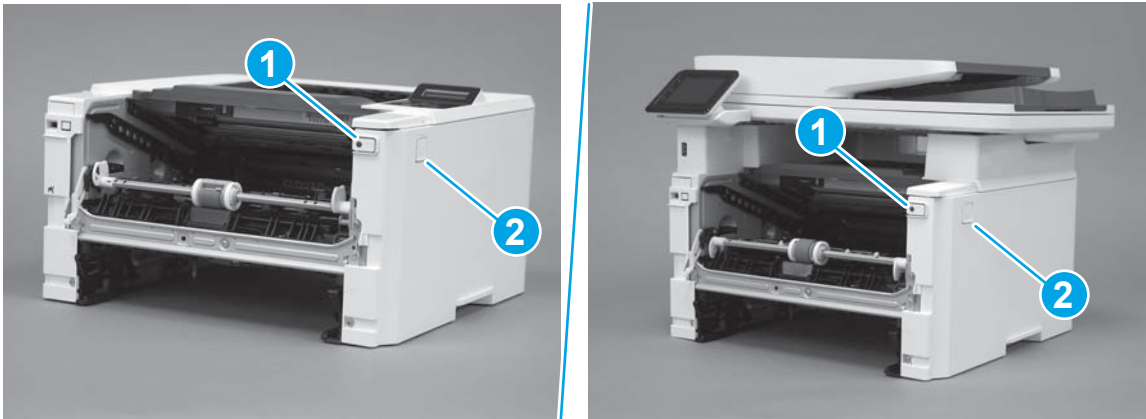

Step 19: Install the left cover

1. At the front of the printer, do one of the following:
 - **M403/M402:** Position the cover on the printer (callout 1), and then engage two bosses (callout 2).
 - **M427/M426:** Position the cover on the printer (callout 3), engage one tab (callout 4), and then engage two bosses (callout 4).

Figure 1-2107 Install the cover

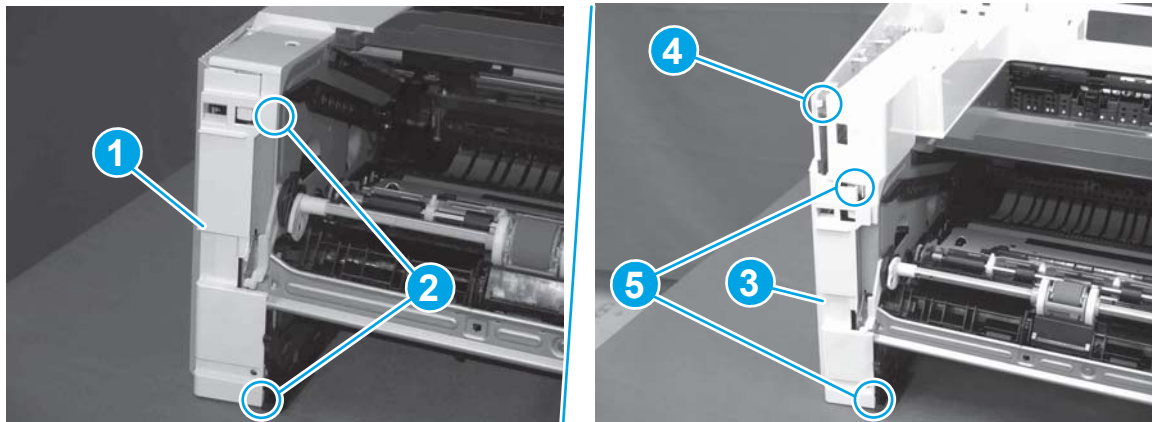

- Carefully rotate the rear of the cover onto the printer (callout 1), engage three tabs (callout 2), and then engage two bosses (callout 3).

Figure 1-2108 Engage three tabs and two bosses

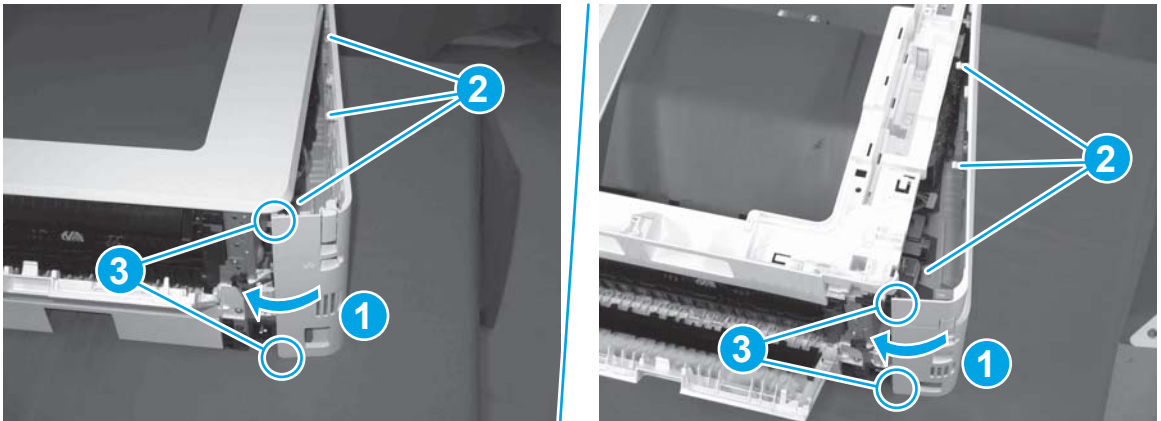

- Install one screw (callout 1).

Figure 1-2109 Install one screw

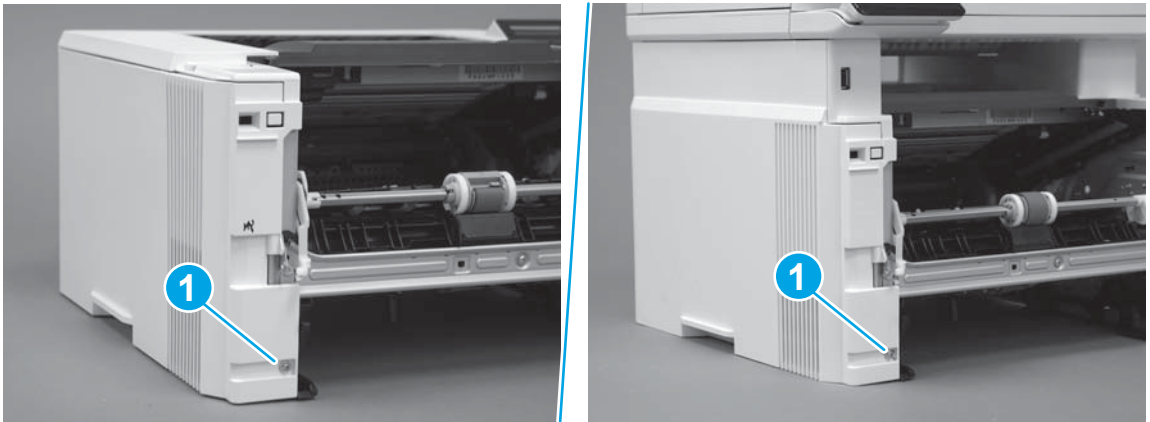

Step 20: Remove the cartridge door assembly

 **Reinstallation tip:** After a replacement door is installed, make sure to install the nameplate (supplied in the kit) corresponding to the printer name on the door.

- Position the door close to the printer, and then engage the keyed pin on the left-side retainer arm with the hole in the door.

Figure 1-2110 Engage the left-side retainer arm

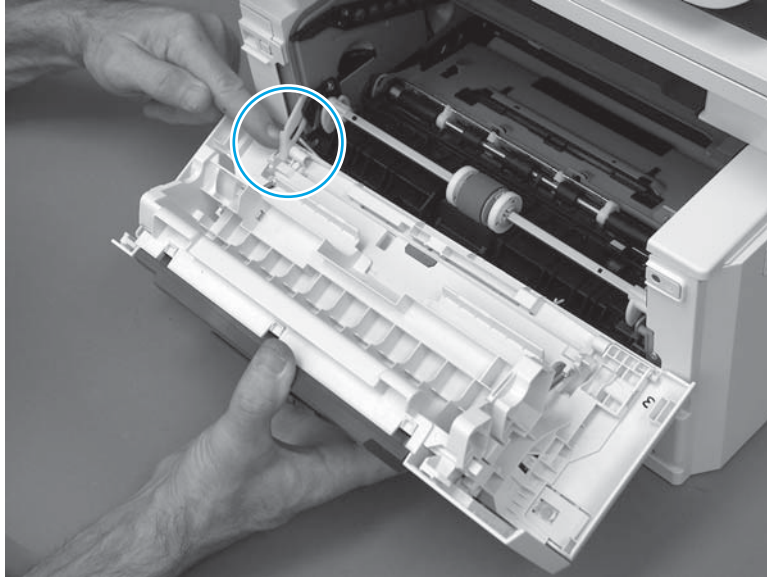

2. Engage the right-side door hinge pin with the hole in the chassis (callout 1).

Figure 1-2111 Install the door

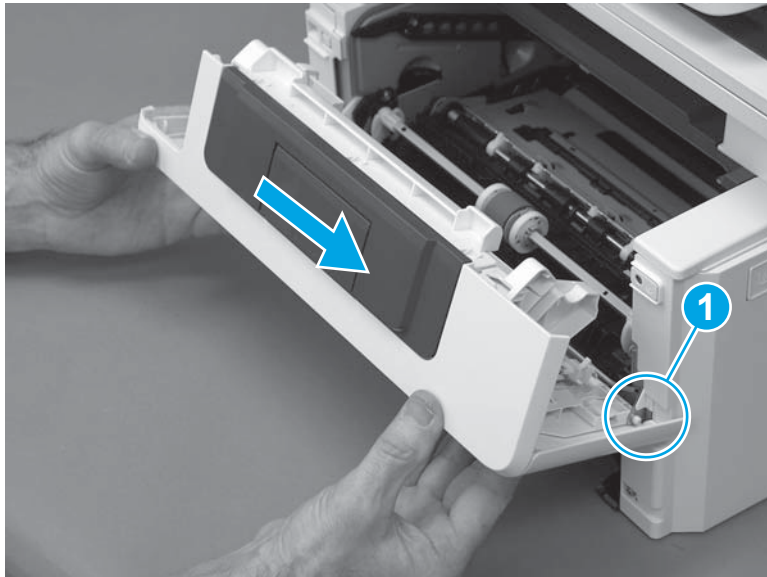

3. Install the link (callout 1).

 **IMPORTANT:** Make sure that the link snaps into place on the arm (callout 2). The link actuates the fuser pressure-release mechanism.

Figure 1-2112 Install the pressure-release link

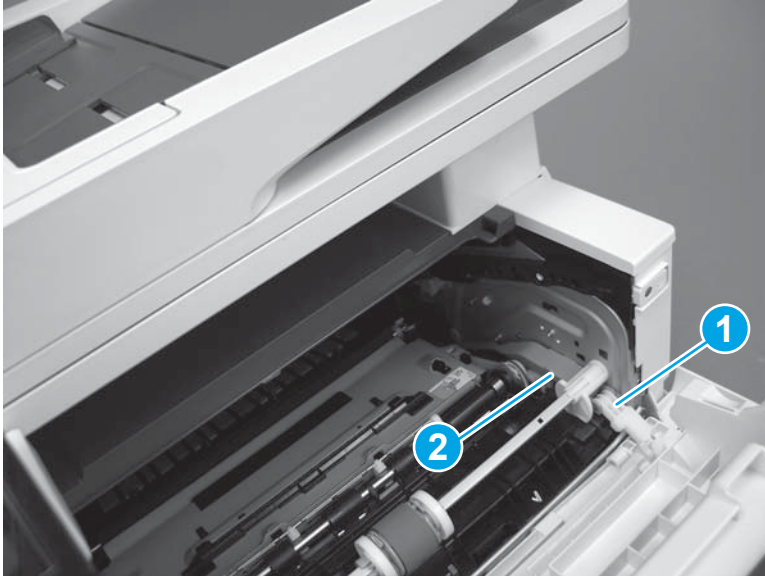

4. Slide the guide into the printer (callout 1), and then make sure that the tab (callout 2) snaps into place to secure the guide to the chassis.

Figure 1-2113 Install the guide

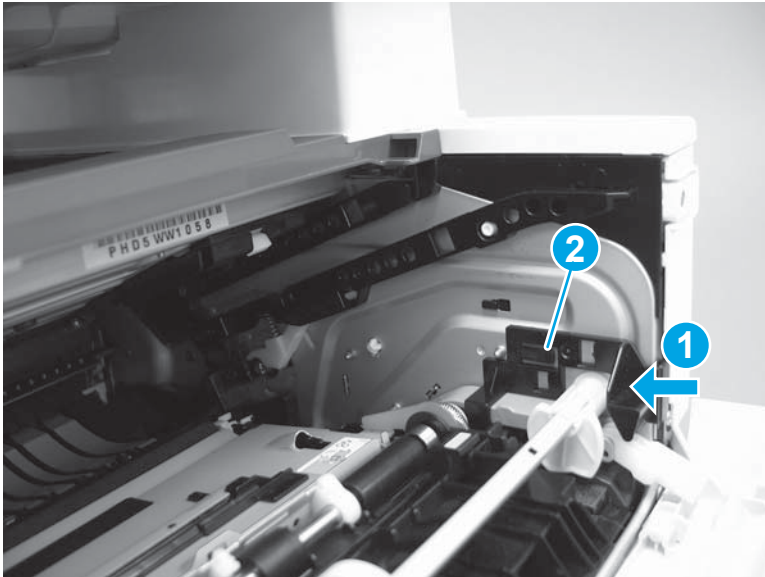

5. Position the shaft on the door, and then align the left-side hinge on the door with the hole in the chassis (callout 1).

Figure 1-2114 Align the hinge

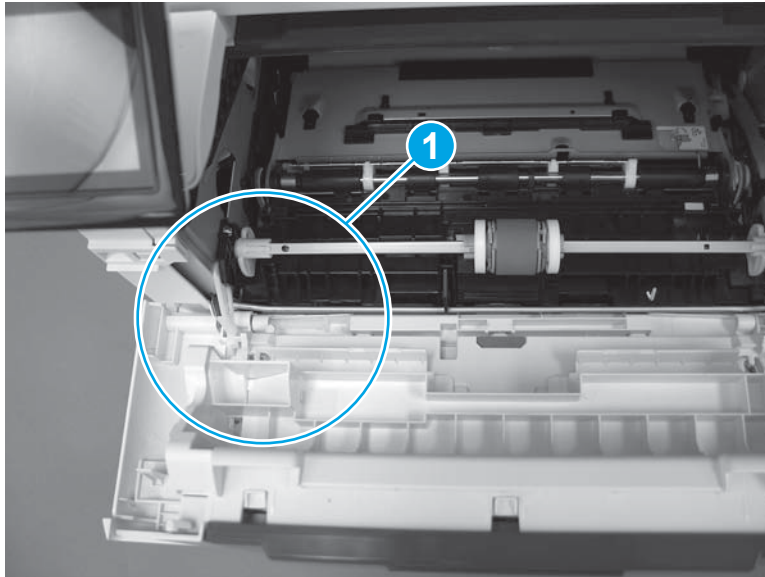

6. Push the shaft towards the left side of the printer to install it (callout 1).

 **Reinstallation tip:** Make sure that the support shaft is fully installed and correctly orientated (callout 2) so that it will not interfere with the door opening and closing.

Figure 1-2115 Install the support shaft



Step 21: Install Tray 2

- ▲ Slide the tray straight into the printer to install it.

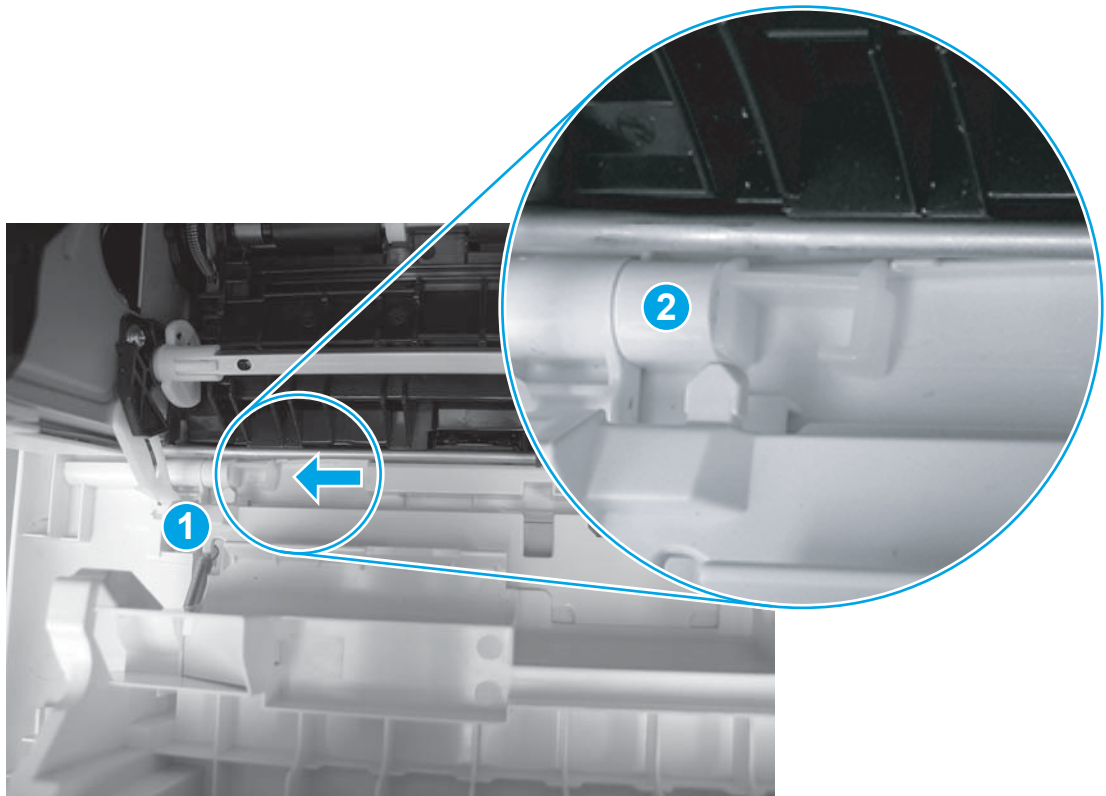
Figure 1-2116 Install the tray



Removal and replacement: Control-panel assembly (M403/M402)

- [Introduction](#)
- [Step 1: Remove Tray 2](#)
- [Step 2: Remove the cartridge door assembly](#)
- [Step 3: Remove the left cover](#)
- [Step 4: Remove the right cover](#)
- [Step 5: Remove the top cover \(M403/M402\)](#)
- [Step 6: Remove the paper delivery tray \(output bin\)](#)
- [Step 7: Remove the control-panel assembly \(M403/M402\)](#)
- [Step 8: Unpack the replacement assembly](#)
- [Step 9: Install the control-panel assembly \(M403/M402\)](#)
- [Step 10: Install the paper delivery tray \(output bin\)](#)
- [Step 11: Install the top cover \(M403/M402\)](#)
- [Step 12: Install the right cover](#)
- [Step 13: Install the left cover](#)
- [Step 14: Install the cartridge door assembly](#)
- [Step 15: Install Tray 2](#)

Introduction

This document provides the procedures to remove and replace the control-panel assembly (M403/M402).

Before performing service

Turn the printer power off

- Disconnect the power cable.

 **WARNING!** To avoid damage to the printer, turn the printer off, wait 30 seconds, and then remove the power cable before attempting to service the printer.

Use the table below to identify the correct part number for your printer. To order the part, go to www.hp.com/buy/parts.

Control-panel assembly (M403/M402) part number	
RM2-5391-000CN	Control-panel assembly (M403/M402)
RM2-5424-000CN	Control-panel assembly (M403/M402; wireless model)

Required tools

- #2 Phillips screwdriver with a magnetic tip.

After performing service

Turn the printer power on

- Connect the power cable.
- Use the power switch to turn the power on.

Post service test

Make sure that the printer initializes to a **Ready** state.

Print a configuration page to make sure that the printer is functioning correctly.

Step 1: Remove Tray 2

- ▲ Pull the tray straight out of the printer to remove it.

Figure 1-2117 Remove the tray



Step 2: Remove the cartridge door assembly

 **NOTE:** If the toner cartridge was not removed prior to servicing the printer, remove it now.

1. Release one tab (callout 1), and then slide shaft (callout 2) in the direction the arrow indicates and remove it.

 **TIP:** It might be easier to release the support shaft by using a small flat-blade screwdriver.

Figure 1-2118 Release the support shaft

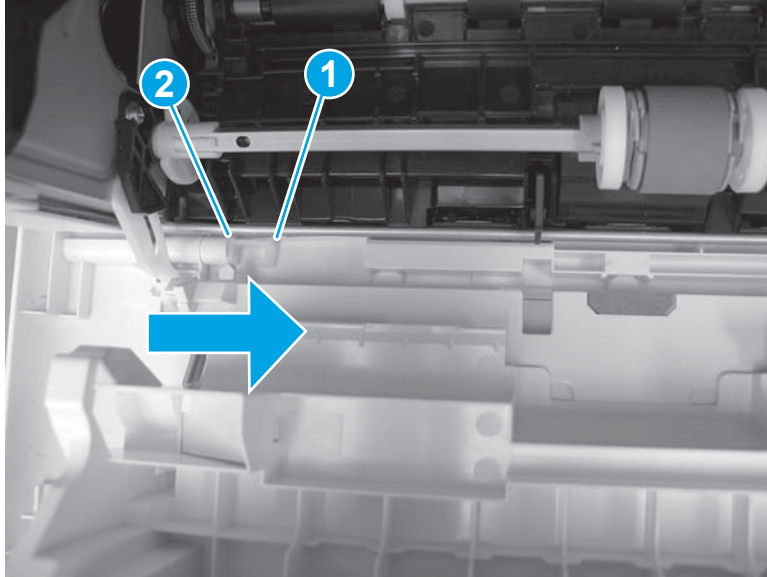

2. Release one tab (callout 1), and then slide the guide (callout 2) in the direction the arrow indicates and remove it.

Figure 1-2119 Remove the guide

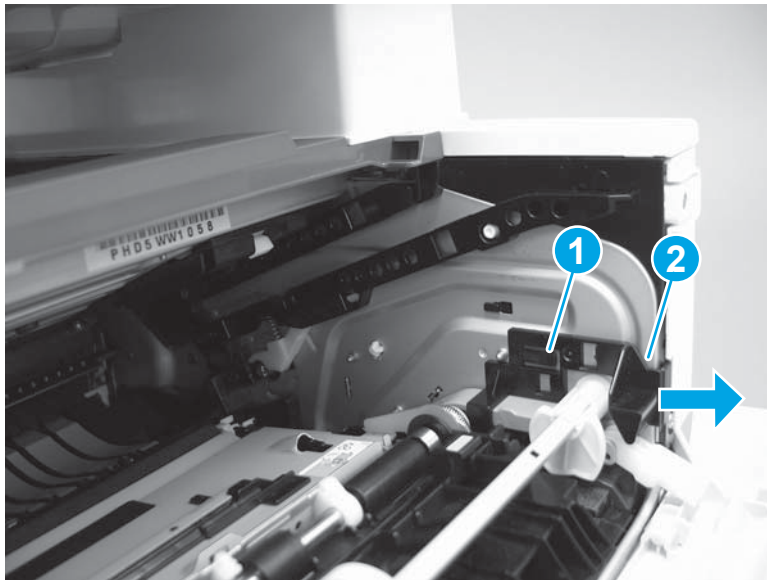

3. Remove the link arm (callout 1).

Figure 1-2120 Remove the link arm

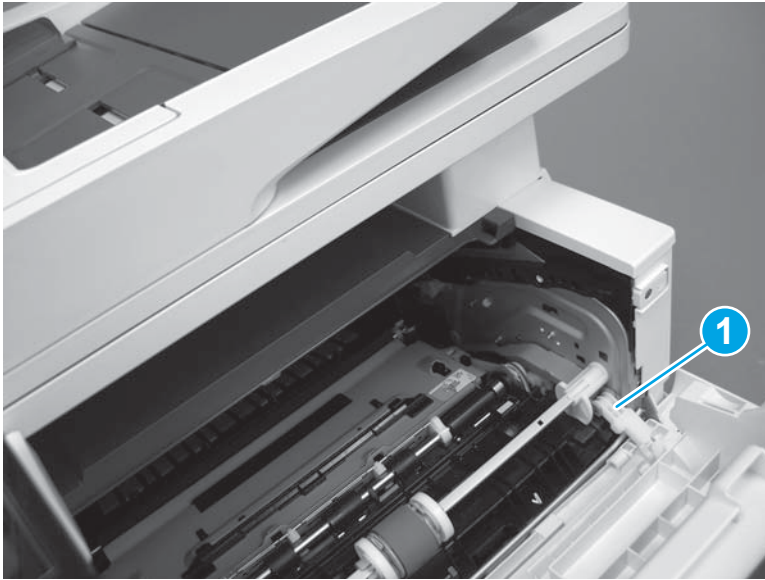

4. Slide the cartridge door assembly (callout 1) in the direction the arrow indicates and remove it.

Figure 1-2121 Remove the door

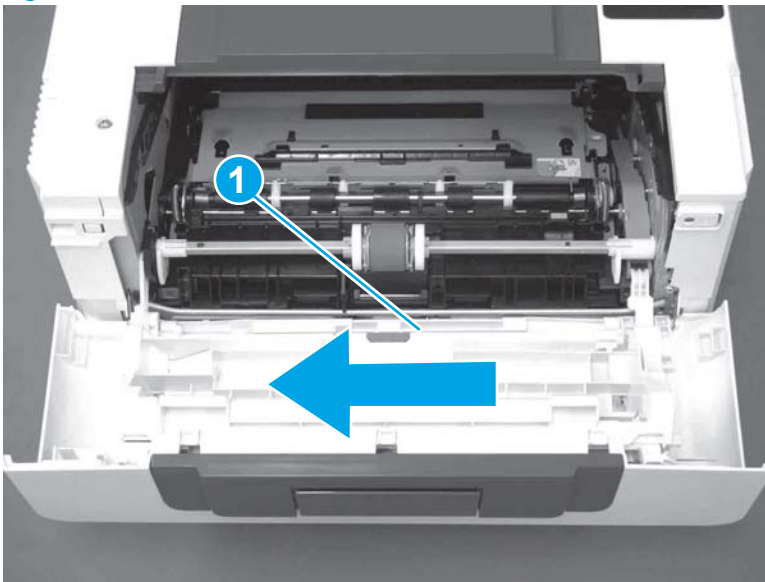

5. Remove the link (callout 1) from the cartridge door assembly (callout 2).

Figure 1-2122 Release the left-side retainer arm

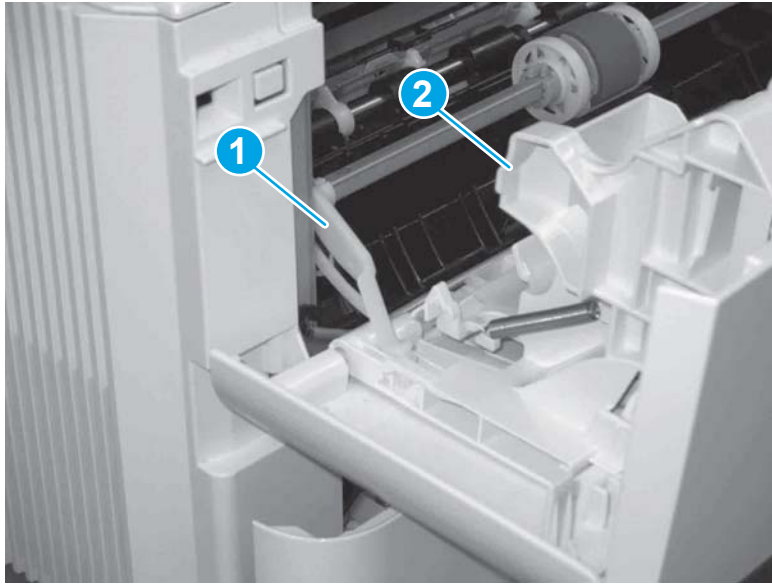

Step 3: Remove the left cover

1. Remove one screw (callout 1).

Figure 1-2123 Remove one screw

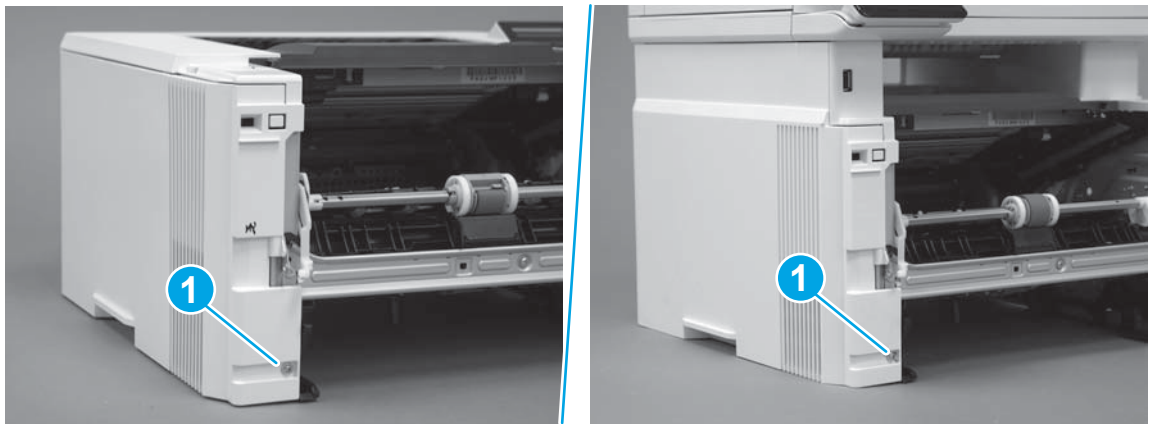

2. Open the rear door, release two bosses (callout 1), and then release three tabs (callout 2).

Figure 1-2124 Release two bosses and three tabs

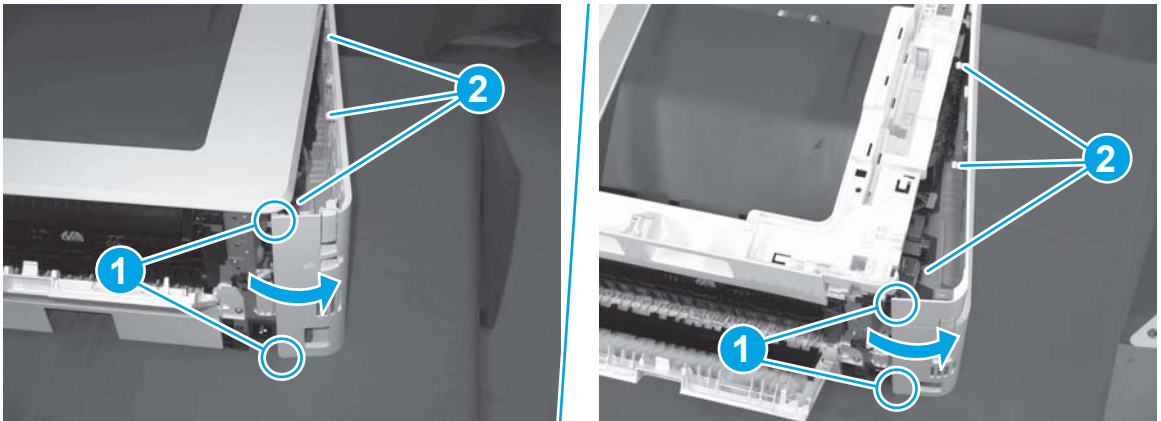

3. At the front of the printer, do one of the following:
 - **M403/M402:** Release two bosses (callout 1), and then remove the cover (callout 2).
 - **M427/M426:** Release one tab (callout 3), two bosses (callout 4), and then remove the cover (callout 5).

CAUTION: Be careful when releasing the upper bosses on the M427/M426 cover. One portion of the cover (callout 6) is fragile and is easily broken.

Figure 1-2125 Remove the cover

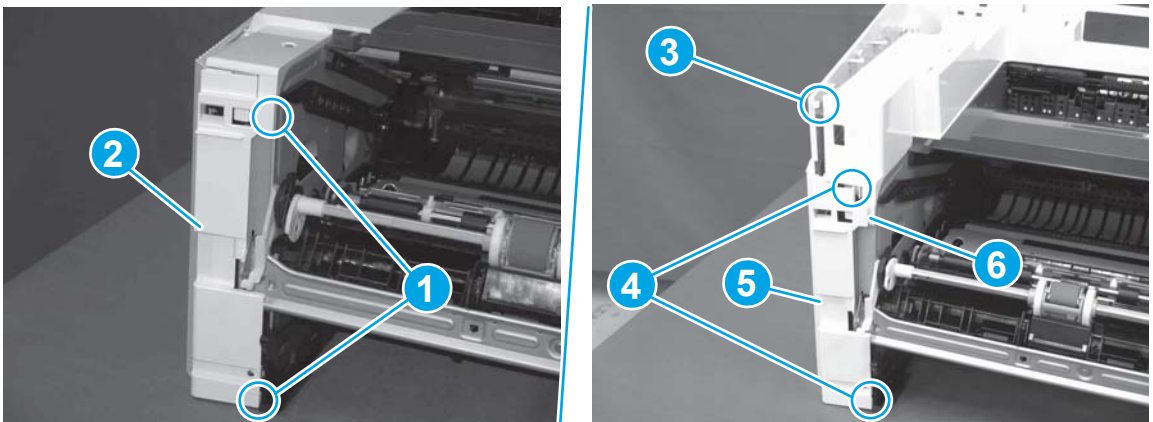

Step 4: Remove the right cover

1. Remove one screw (callout 1).

Figure 1-2126 Remove one screw

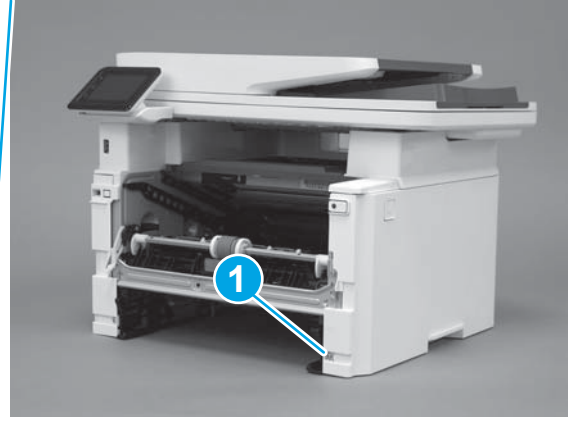
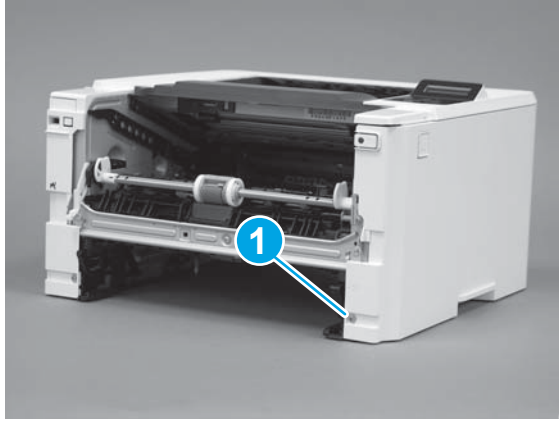

2. At the front of the printer, release two bosses (callout 1), and then release three tabs (callout 2).

Figure 1-2127 Release two bosses and three tabs

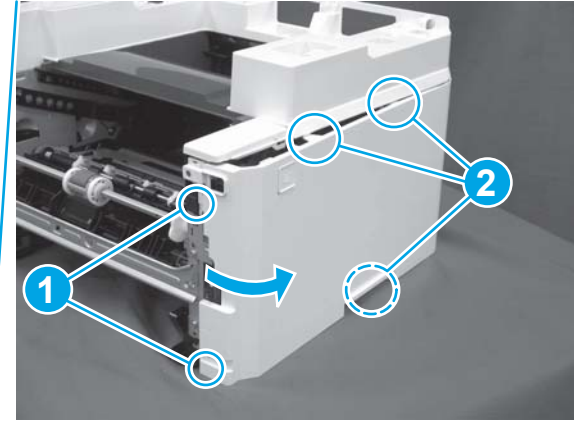
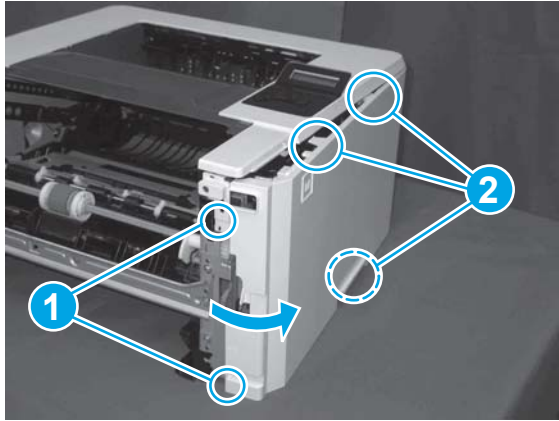

3. Open the rear door, release two bosses (callout 1), and then remove the cover (callout 2).

Figure 1-2128 Remove the cover

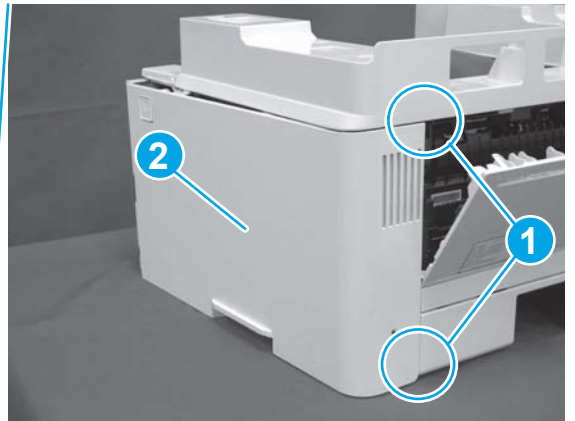
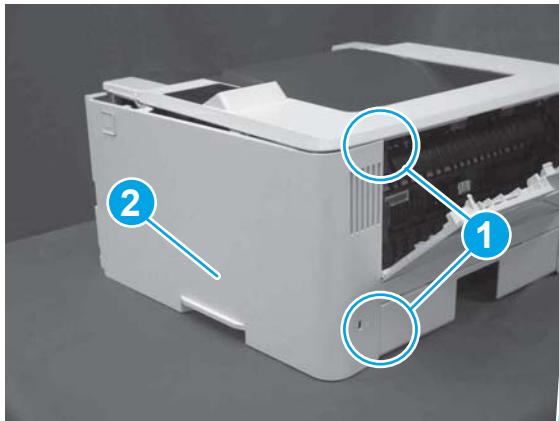

Step 5: Remove the top cover (M403/M402)

1. Remove one screw (callout 1).

Figure 1-2129 Remove one screw



2. At the right side of the printer, release the one boss (callout 1), and then release one tab (callout 2).

Figure 1-2130 Release one boss and one tab

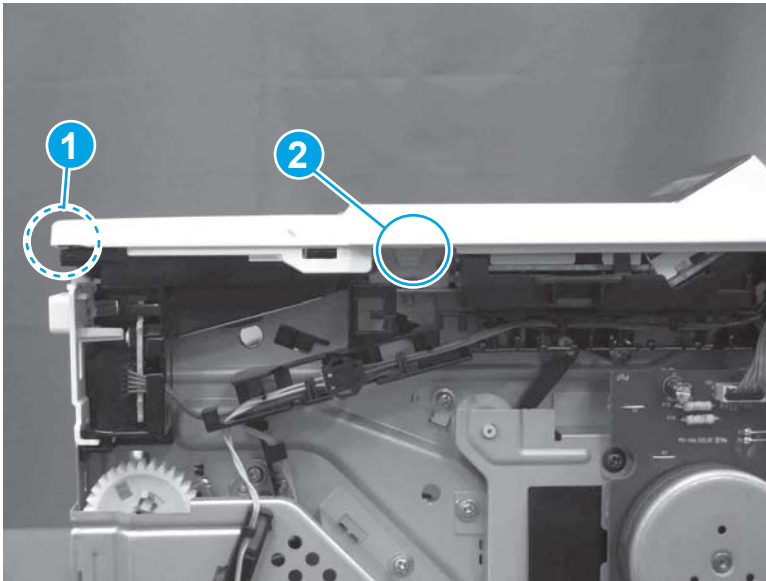

3. Release four tabs (callout 1), release four bosses (callout 2), and then remove the top cover (callout 3).



 **TIP:** Open the rear door to make releasing the bosses (callout 3) easier.

Figure 1-2131 Remove the cover

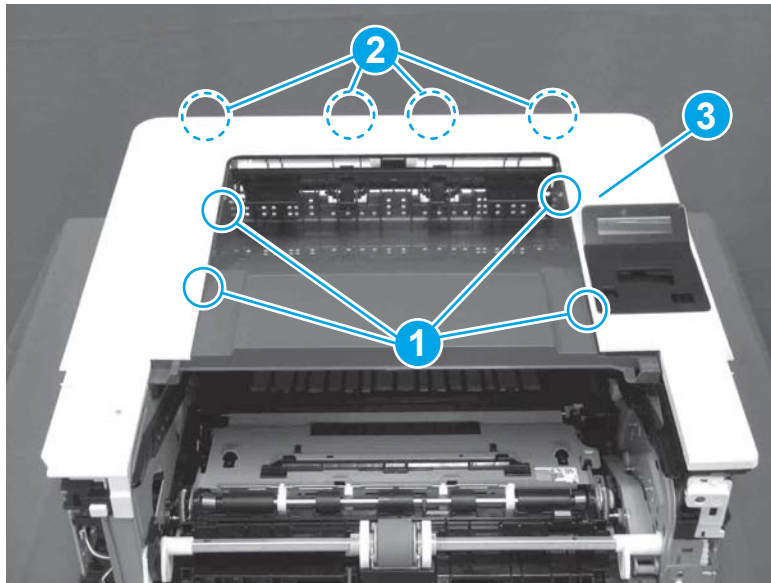

Step 6: Remove the paper delivery tray (output bin)

 **NOTE:** This procedure shows the M403/M402 model, however, the paper delivery tray (output bin) removal is similar for the M427/M426 printer.

- ▲ Release two bosses (callout 1), release two tabs (callout 2), and then remove the paper delivery tray (output bin; callout 3).

Figure 1-2132 Release two tabs

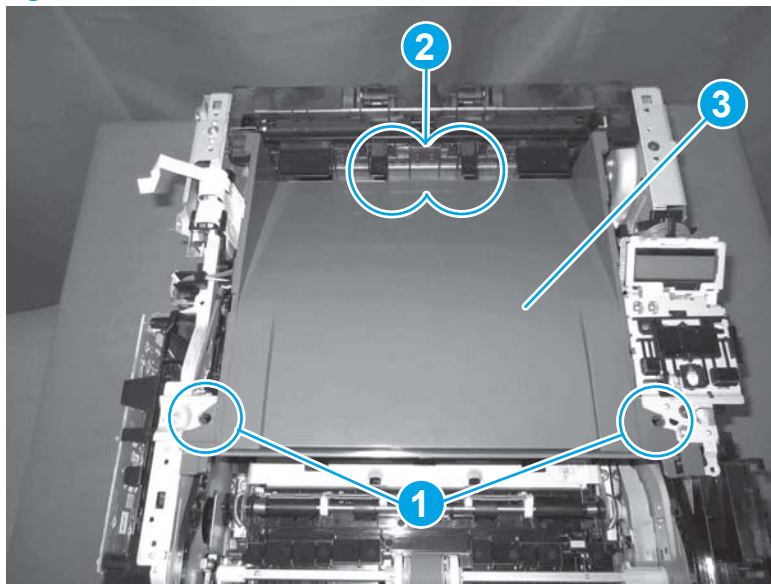

Step 7: Remove the control-panel assembly (M403/M402)

1. Disconnect one FFC (callout 1).

Figure 1-2133 Disconnect one FFC

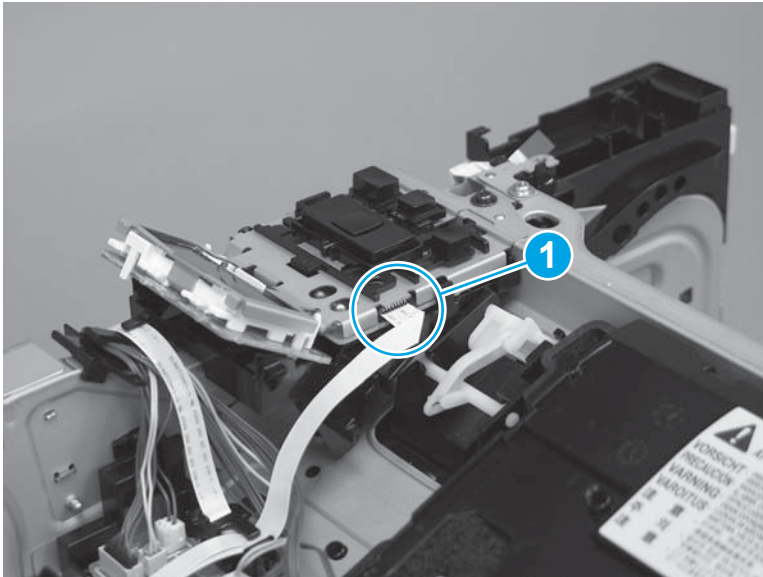

2. Remove one screw (callout 1), and then remove the control panel.

Figure 1-2134 Remove one screw and the control panel

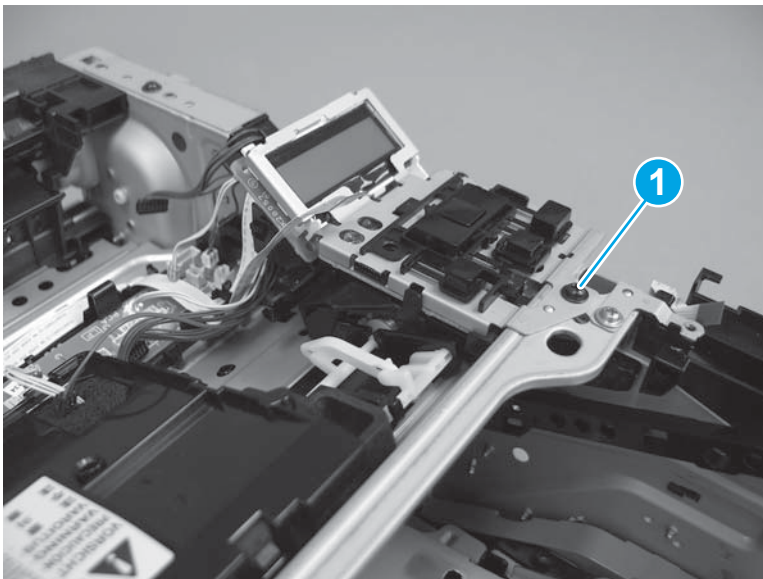

Step 8: Unpack the replacement assembly

Unpack the replacement part from the packaging.

<http://www8.hp.com/us/en/hp-information/environment/product-recycling.html>

 **NOTE:** HP recommends responsible disposal of the defective part.

Figure 1-2135 Recycle and unpack

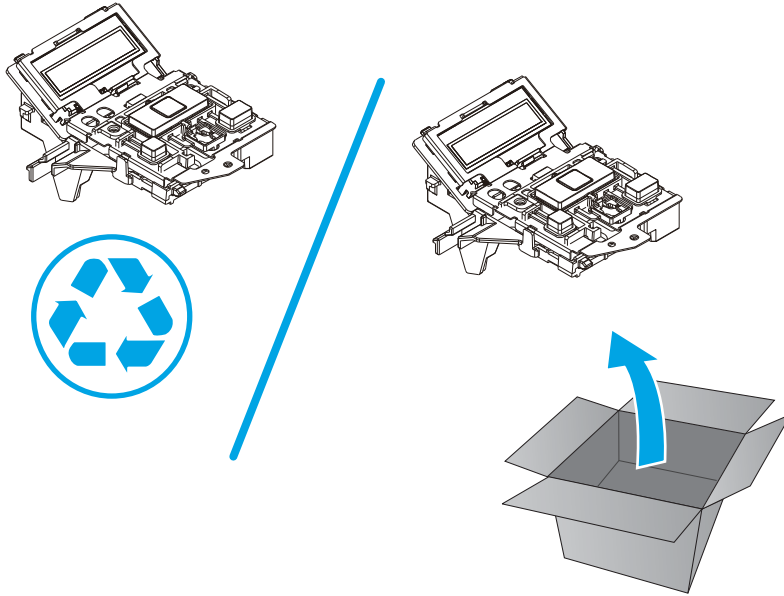

Step 9: Install the control-panel assembly (M403/M402)

1. Position the control panel on the chassis, and then install one screw (callout 1).

Figure 1-2136 Install the control panel and one screw

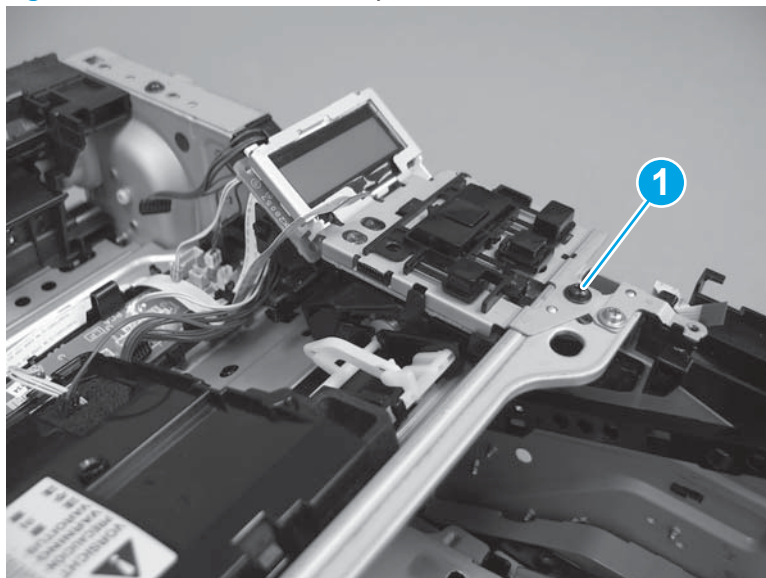

2. Connect one FFC (callout 1).

Figure 1-2137 Connect one FFC

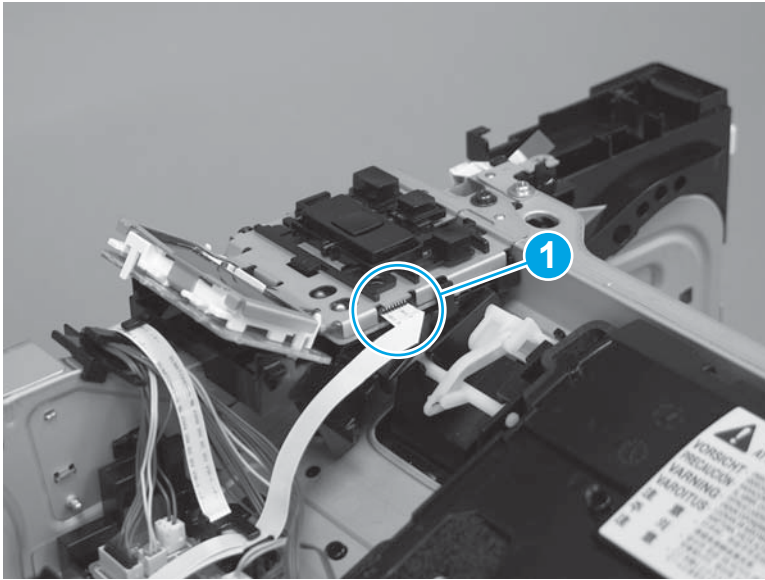

Step 10: Install the paper delivery tray (output bin)

 **NOTE:** This procedure shows the M403/M402 model, however, the paper delivery tray (output bin) removal is similar for the M427/M426 printer.

- ▲ Position the remove the paper delivery tray (output bin; callout 1) on the printer, engage two tabs (callout 2), and then engage two bosses (callout 3).

Figure 1-2138 Engage two tabs

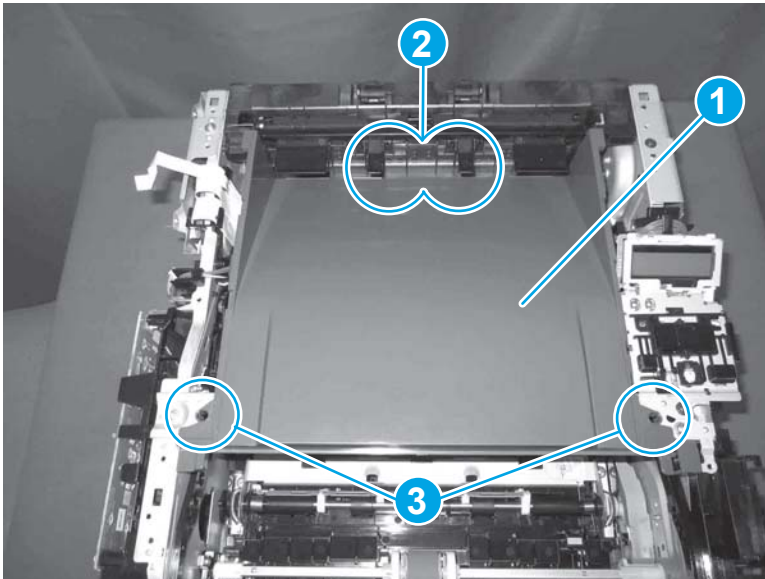

Step 11: Install the top cover (M403/M402)

1. Position the rear edge of the cover on the printer.

Figure 1-2139 Install the cover

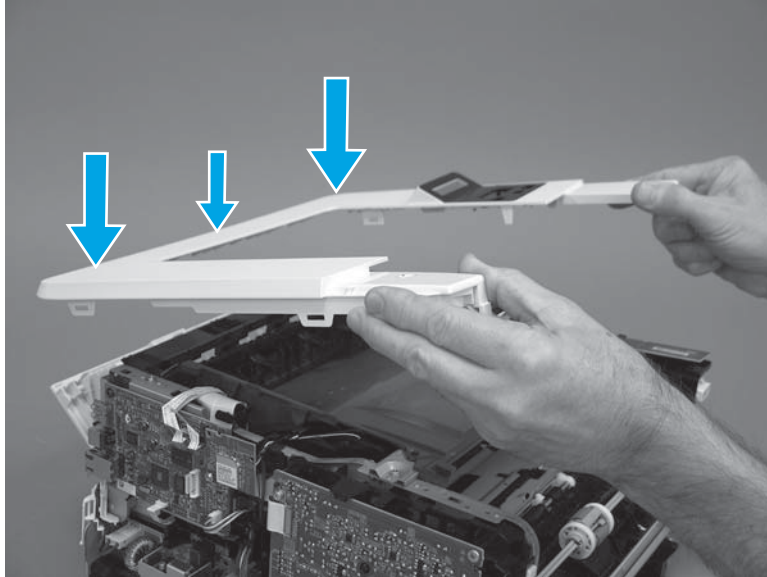

2. Engage four bosses (callout 1), rotate the front of the cover down (callout 2) and onto from the printer, and then engage four tabs (callout 3).

Figure 1-2140 Engage four bosses and tabs

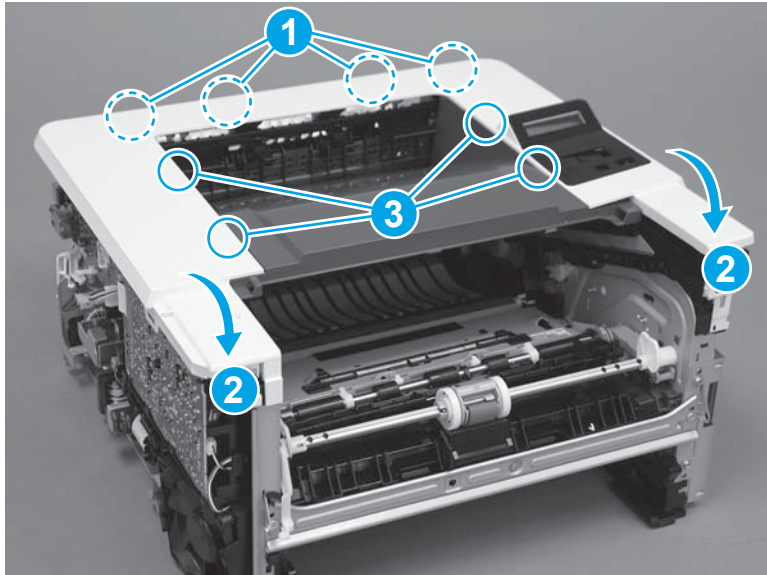

3. At the right side of the printer, engage the one boss and one tab (callout 1).

Figure 1-2141 Engage one boss and one tab

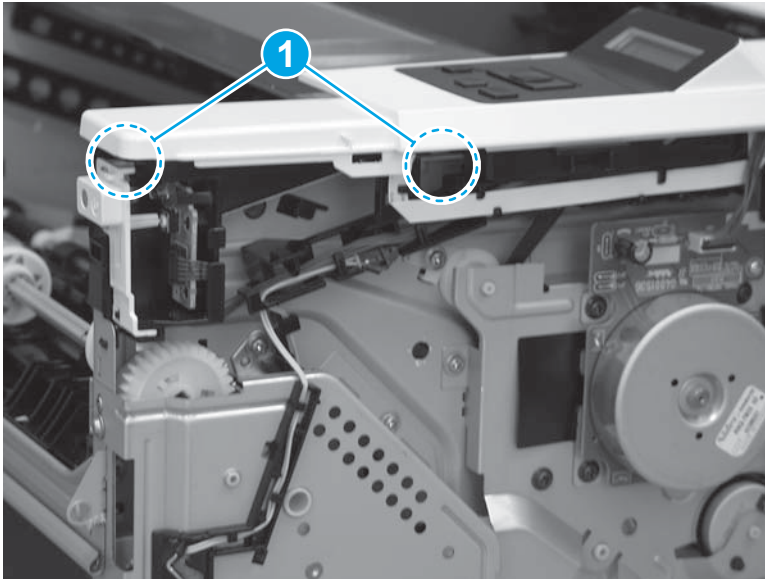

4. Install one screw (callout 1).

Figure 1-2142 Install one screw

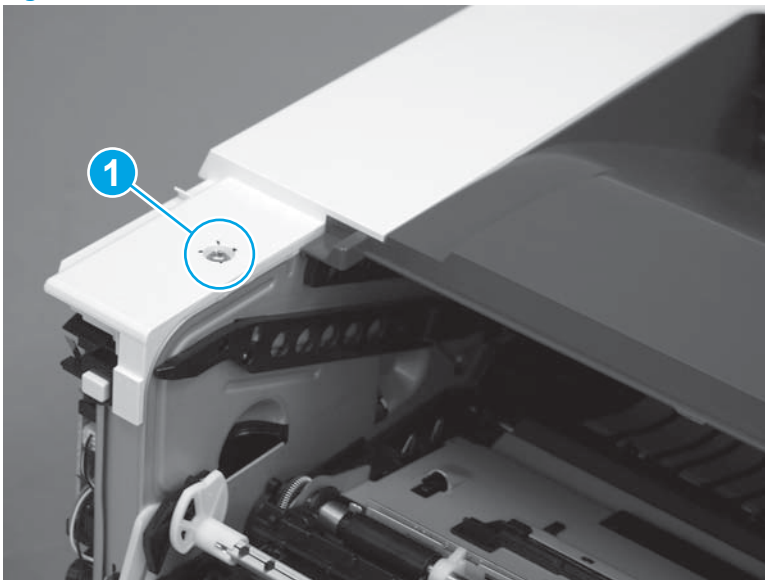

Step 12: Install the right cover

1. Position the cover (callout 1) on the printer, and then engage two bosses (callout 2).

Figure 1-2143 Install the cover

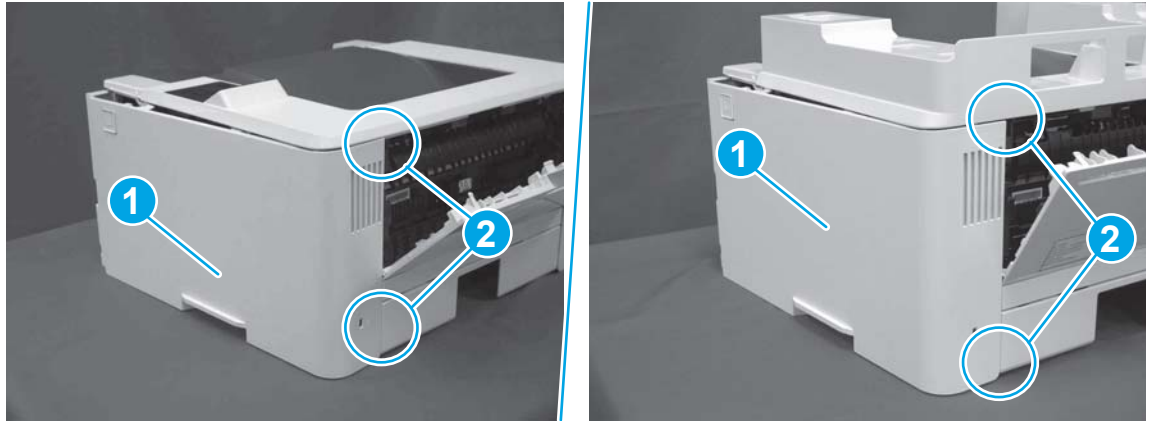

2. Rotate the front of the cover onto the printer (callout 1), engage three (callout 2) tabs, and then engage two bosses (callout 3).

Figure 1-2144 Engage two bosses and one tab

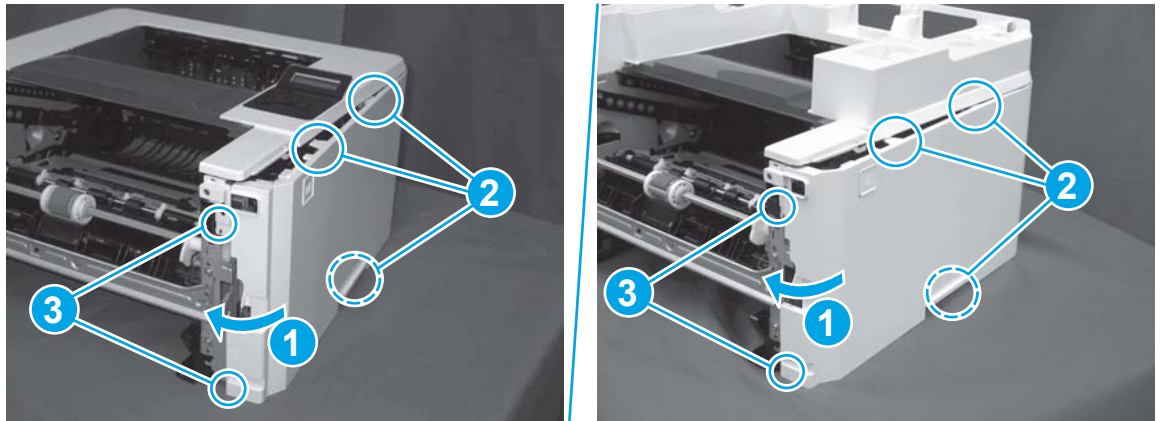

3. Make sure that the power switch (callout 1) and cartridge door assembly button (callout 2) correctly function.



NOTE: Remove, and then reinstall the cover if the switch or button does not correctly function.

Figure 1-2145 Check the power switch and cartridge door assembly button

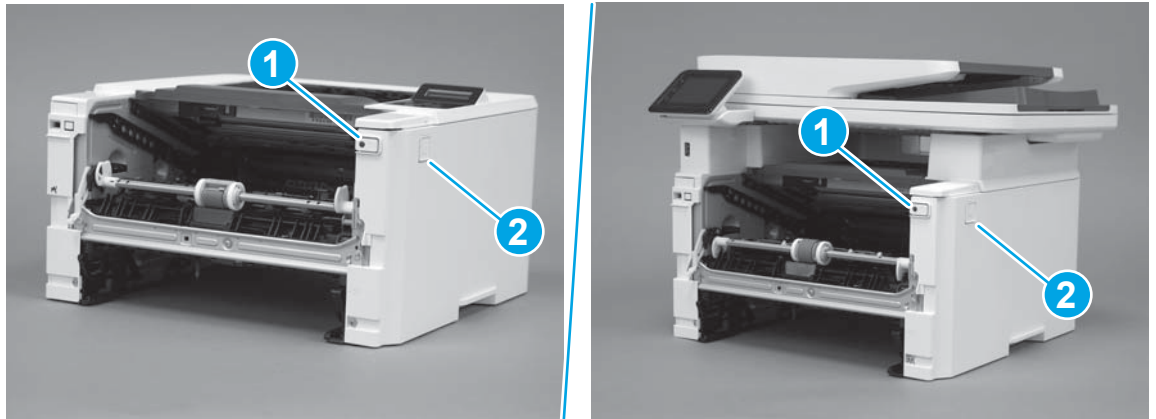

4. Install one screw (callout 1).

Figure 1-2146 Install one screw



Step 13: Install the left cover

1. At the front of the printer, do one of the following:
 - **M403/M402:** Position the cover on the printer (callout 1), and then engage two bosses (callout 2).
 - **M427/M426:** Position the cover on the printer (callout 3), engage one tab (callout 4), and then engage two bosses (callout 4).

Figure 1-2147 Install the cover

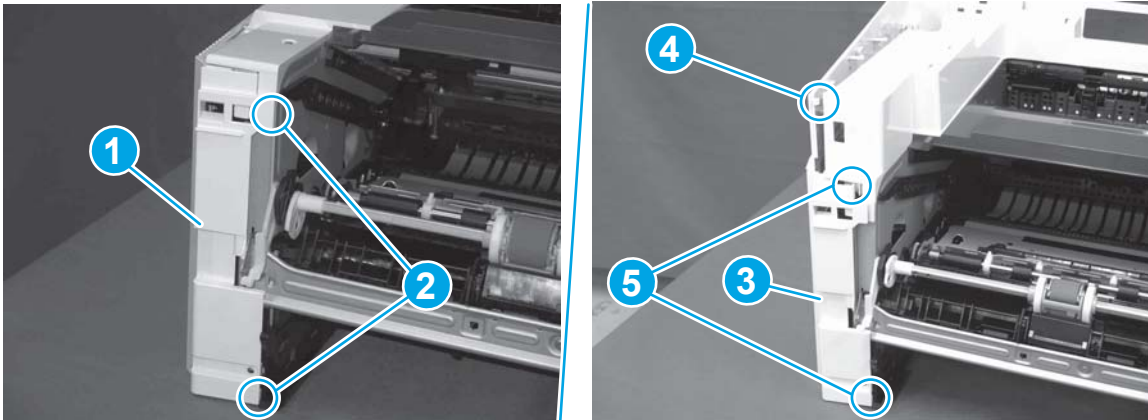

- Carefully rotate the rear of the cover onto the printer (callout 1), engage three tabs (callout 2), and then engage two bosses (callout 3).

Figure 1-2148 Engage three tabs and two bosses

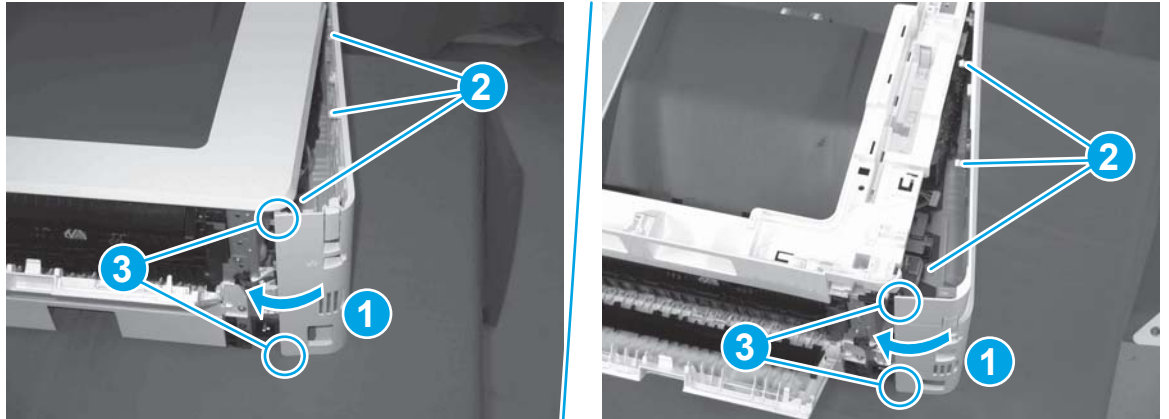

- Install one screw (callout 1).

Figure 1-2149 Install one screw

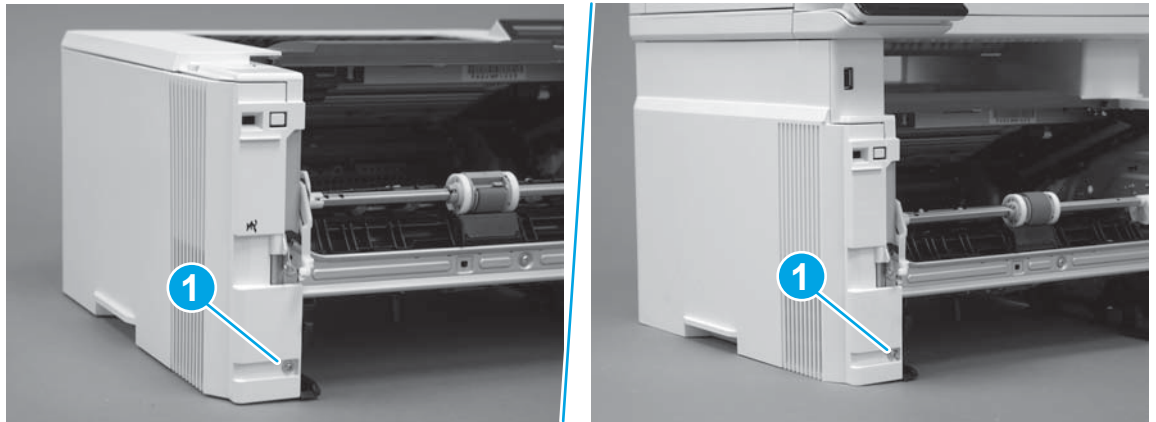

Step 14: Install the cartridge door assembly

 **Reinstallation tip:** After a replacement door is installed, make sure to install the nameplate (supplied in the kit) corresponding to the printer name on the door.

- Position the door close to the printer, and then engage the keyed pin on the left-side retainer arm with the hole in the door.

Figure 1-2150 Engage the left-side retainer arm

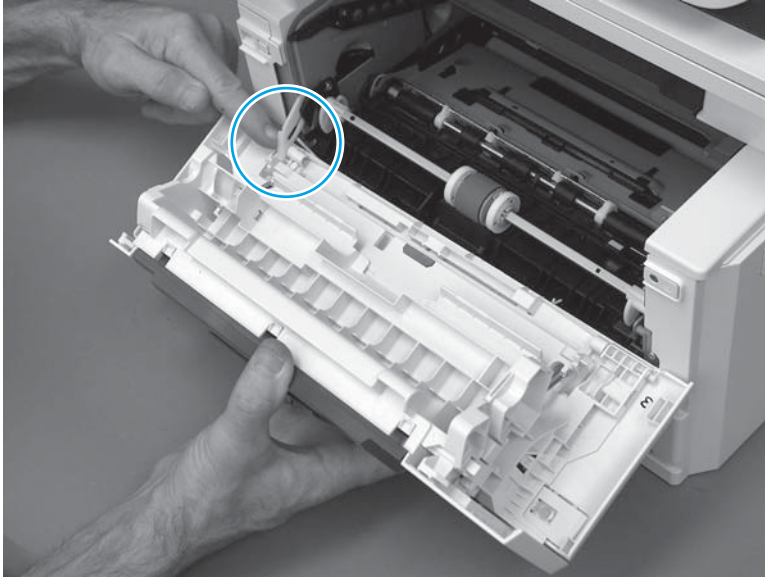

2. Engage the right-side door hinge pin with the hole in the chassis (callout 1).

Figure 1-2151 Install the door

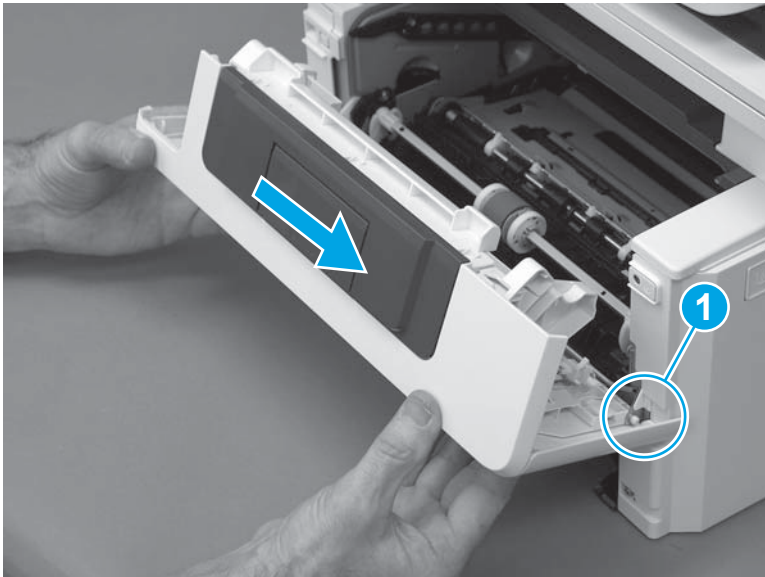

3. Install the link (callout 1).

 **IMPORTANT:** Make sure that the link snaps into place on the arm (callout 2). The link actuates the fuser pressure-release mechanism.

Figure 1-2152 Install the pressure-release link

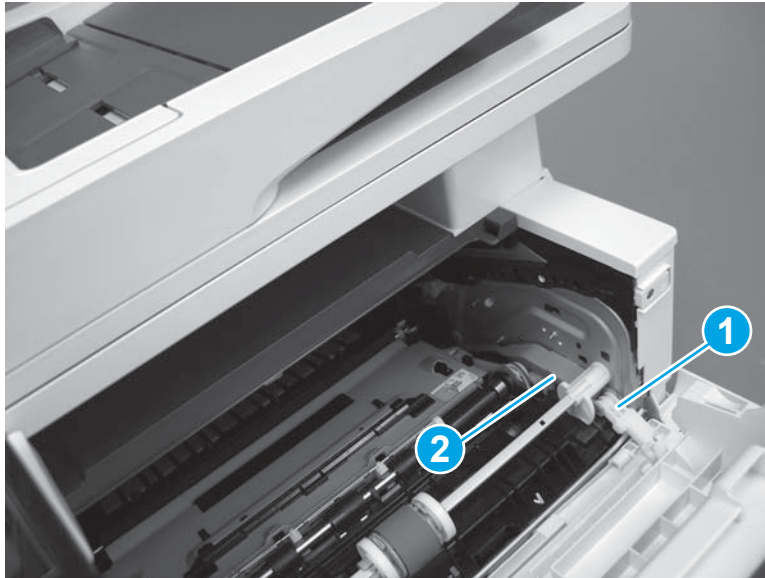

4. Slide the guide into the printer (callout 1), and then make sure that the tab (callout 2) snaps into place to secure the guide to the chassis.

Figure 1-2153 Install the guide

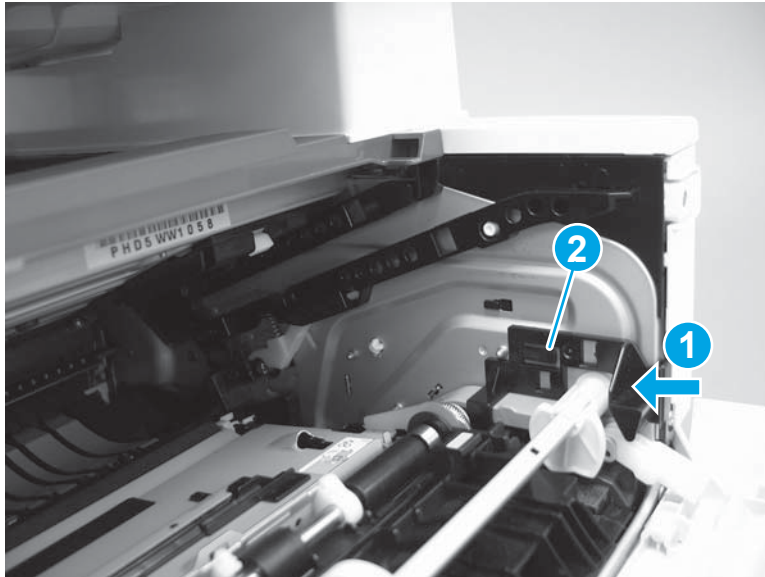

5. Position the shaft on the door, and then align the left-side hinge on the door with the hole in the chassis (callout 1).

Figure 1-2154 Align the hinge

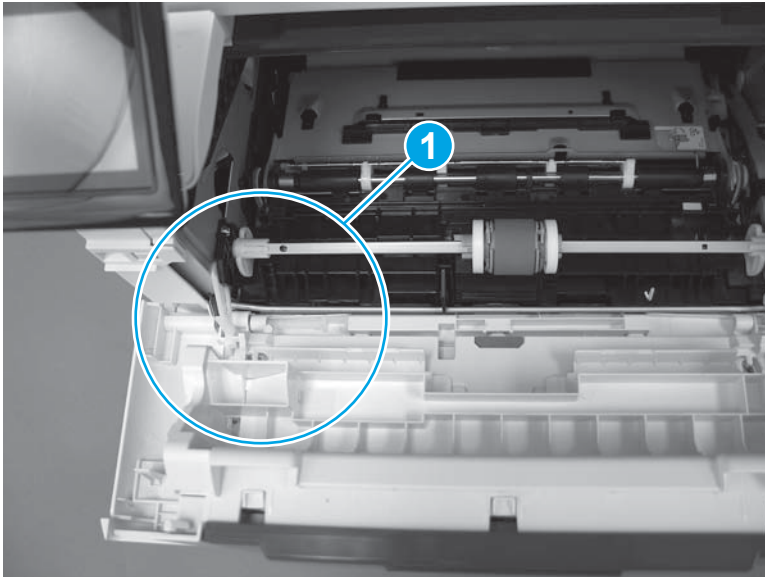

6. Push the shaft towards the left side of the printer to install it (callout 1).

 **Reinstallation tip:** Make sure that the support shaft is fully installed and correctly orientated (callout 2) so that it will not interfere with the door opening and closing.

Figure 1-2155 Install the support shaft



Step 15: Install Tray 2

- ▲ Slide the tray straight into the printer to install it.

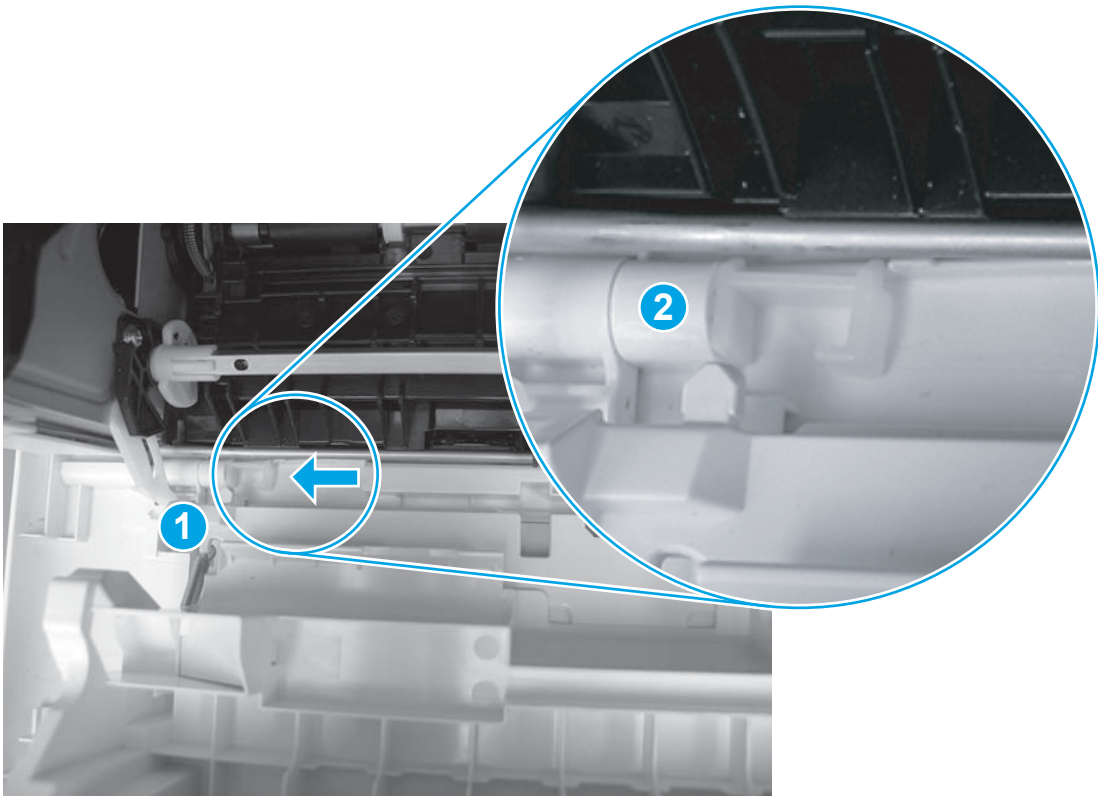
Figure 1-2156 Install the tray



Removal and replacement: Control panel (M427/M426) and control panel sub assemblies

- [Introduction](#)
- [Step 1: Remove the control panel mount cover \(M427/M426\)](#)
- [Step 2: Remove the control panel \(M427/M426\)](#)
- [Step 3: Remove the control panel mount base \(M427/M426\)](#)
- [Step 4: Remove the control panel mount chassis assembly \(M427/M426\)](#)
- [Step 5: Remove Tray 2](#)
- [Step 6: Remove the cartridge door assembly](#)
- [Step 7: Remove the left cover](#)
- [Step 8: Remove the control panel 22-pin FFC \(M427/M426\)](#)
- [Step 9: Unpack the replacement assembly](#)
- [Step 10: Install the control panel 22-pin FFC \(M427/M426\)](#)
- [Step 11: Install the left cover](#)
- [Step 12: Install the cartridge door assembly](#)
- [Step 13: Install Tray 2](#)
- [Step 14: Install the control panel mount chassis assembly \(M427/M426\)](#)
- [Step 15: Install the control panel mount base \(M427/M426\)](#)
- [Step 16: Install the control panel \(M427/M426\)](#)
- [Step 17: Install the control panel mount cover \(M427/M426\)](#)

Introduction

This document provides the procedures to remove and replace the M427/M426 control panel, control panel mount cover, control panel base, control panel mount chassis assembly, and the control panel 22-pin flat flexible cable (FFC).

Before performing service

Turn the printer power off

- Disconnect the power cable.

 **WARNING!** To avoid damage to the printer, turn the printer off, wait 30 seconds, and then remove the power cable before attempting to service the printer.

Use the table below to identify the correct part number for your printer. To order the part, go to www.hp.com/buy/parts.

Control panel (M427/M426) part numbers

B3Q10-60139	Control panel (M427/M426; 76.2 mm (3.0 in))
B3Q10-40056	Cover, back control panel (M427/M426)
B3Q11-40002	Control panel mount cover (M427/M426)
B3Q11-40001	Control panel mount base (M427/M426)
B3Q10-60145	Control panel mount chassis (M427/M426)
C5F98-60104	Control panel 22-pin FFC (M427/M426)

NOTE: If the control panel is damaged, order the following parts and assemble them together.

- B3Q10-60139
 - B3Q10-40056
-

Required tools

- #2 Phillips screwdriver with a magnetic tip.

After performing service

Turn the printer power on

- Connect the power cable.
- Use the power switch to turn the power on.

Post service test

Make sure that the printer initializes to a **Ready** state.

Navigate the control-panel menus to make sure that the control panel is correctly functioning.

 **TIP:** If the control panel is not functioning, check the FFC connections at the formatter and control panel. See [Step 10: Install the control panel 22-pin FFC \(M427/M426\) on page 1150](#) and [Step 16: Install the control panel \(M427/M426\) on page 1159](#).

Step 1: Remove the control panel mount cover (M427/M426)

1. Open the integrated scanner assembly (ISA).

 **NOTE:** If the control panel is not fully tilted forward, tilt it forward now until it stops.

Figure 1-2157 Open the ISA



2. Remove one screw (callout 1).

Figure 1-2158 Remove one screw

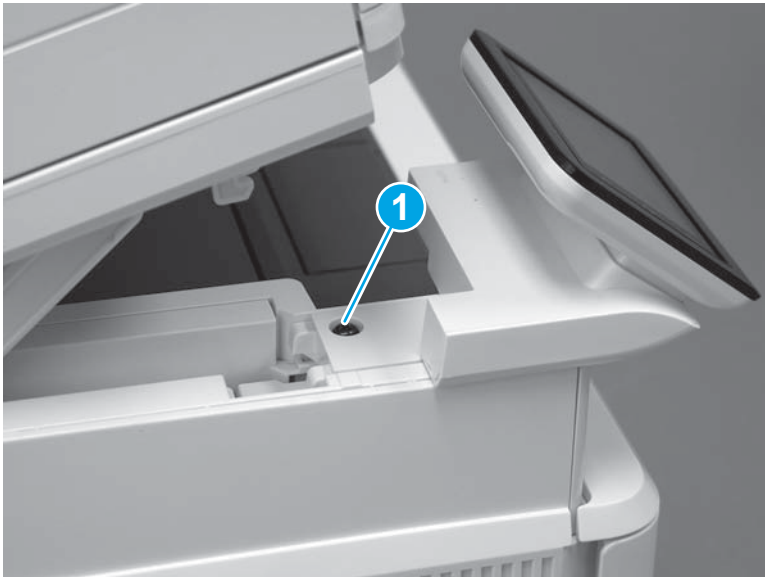

3. Use a small flat-blade screwdriver to release two tabs (callout 1) on the control-panel cable cover.

Figure 1-2159 Release two tabs



4. Rotate the control-panel cable cover up towards the control panel to release it, and then remove the cover.

Figure 1-2160 Remove the cover



Step 2: Remove the control panel (M427/M426)

1. Remove one ground screw (callout 1).

Figure 1-2161 Remove one screw

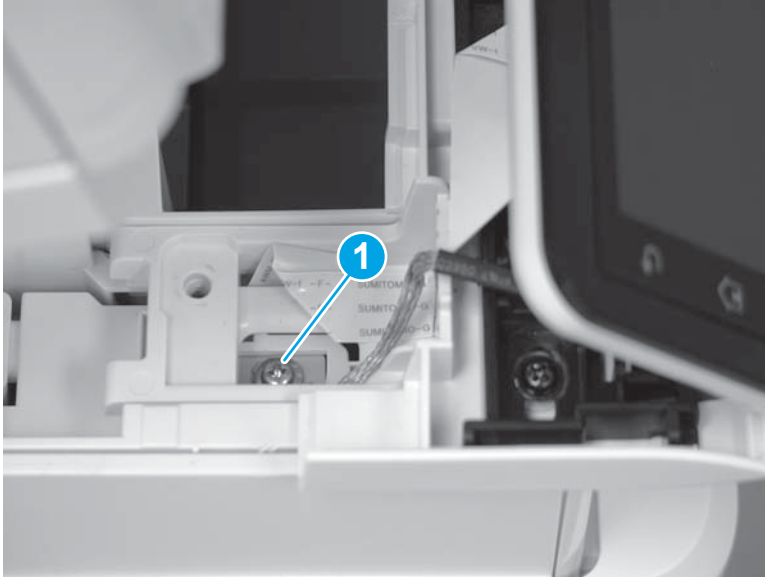

2. Gently tilt the control panel farther forward about 3.18 mm (.125 in).

⚠ CAUTION: Do not use excessive force. The black-plastic mounting retainer (callout 1) for the control-panel hinge pin is easily broken

Figure 1-2162 Tilt the control panel farther forward



3. Slightly shift the control panel in the direction of the arrow about 6.35 mm (.25 in) to remove it.

⚠ CAUTION: Do not twist the control panel. The black-plastic mounting retainer (callout 1) for the control-panel hinge pin is easily broken

Figure 1-2163 Release the control panel

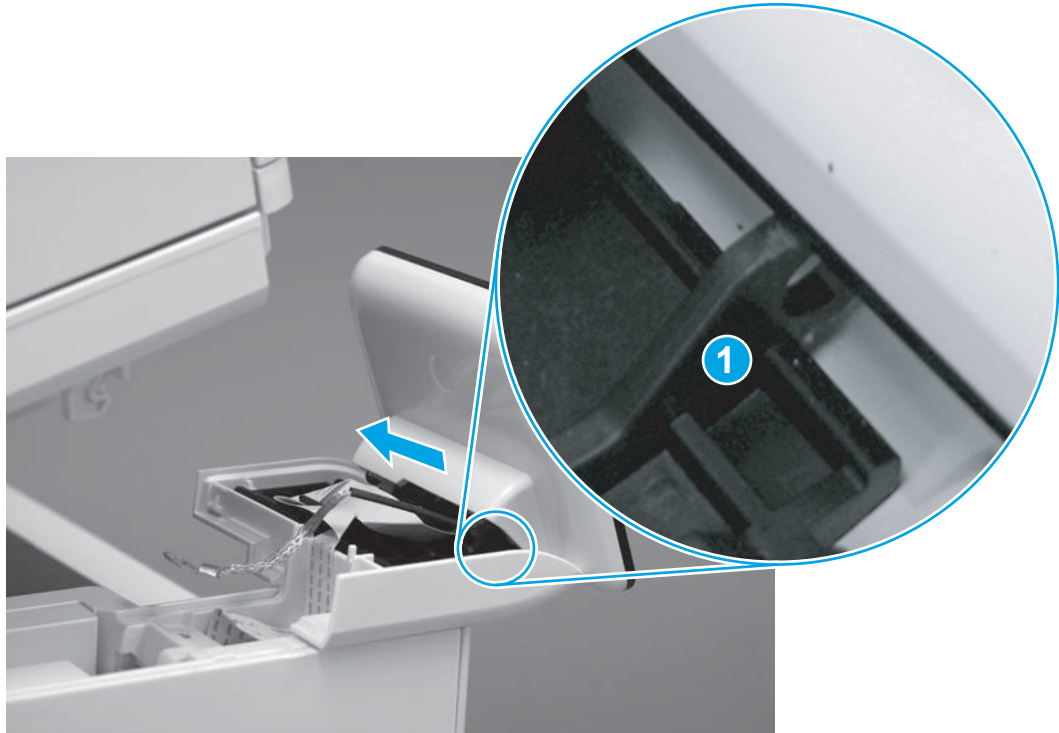

4. Separate the control panel from the printer.

⚠ CAUTION: The control panel is still connected to the mounting printer by a FFC. Do not attempt to completely remove the control panel.

Figure 1-2164 Separate the control panel from the printer

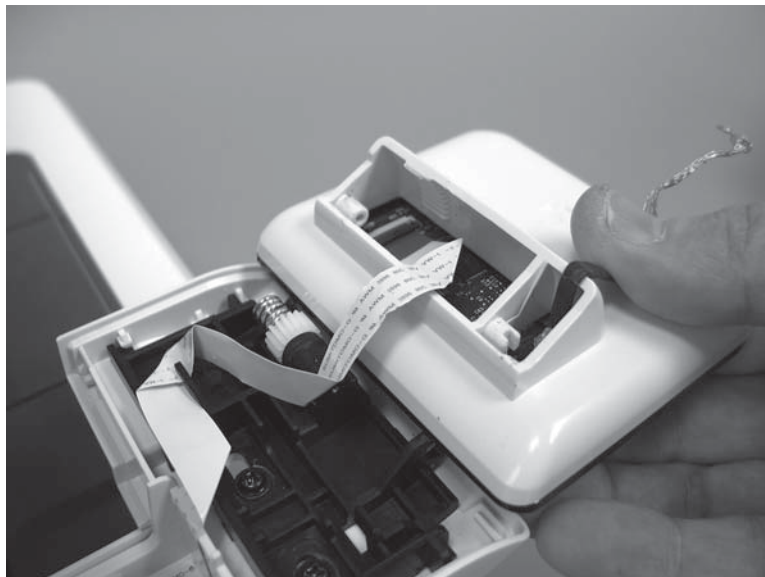

5. Open the hinged latch to release the FFC, and then remove the control panel.

⚠ CAUTION: Be careful. Do not dislodge the latch from the connector.

Figure 1-2165 Release the FFC and remove the control panel

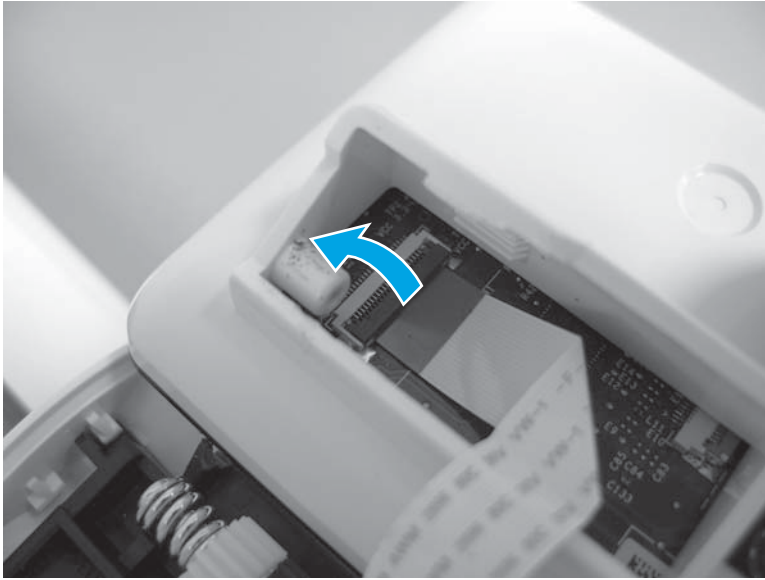

Step 3: Remove the control panel mount base (M427/M426)

1. Remove two screws (callout 1).

Figure 1-2166 Remove two screws

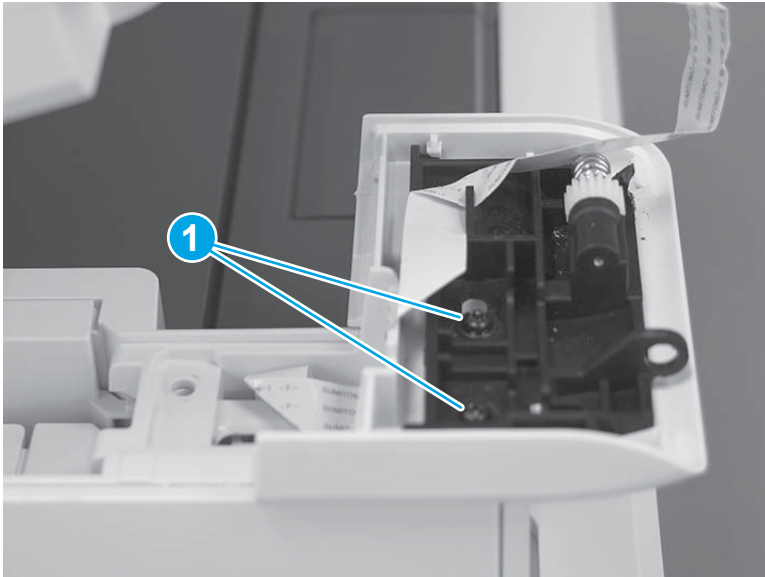

2. Release the FFC from the retainer (callout 1), and then gently remove the FFC from mount base (callout 2).

CAUTION: The FFC is adhered to the mount base with two-sided tape (callout 2). Do not damage the FFC when removing it from the mount base.

Figure 1-2167 Remove the FFC

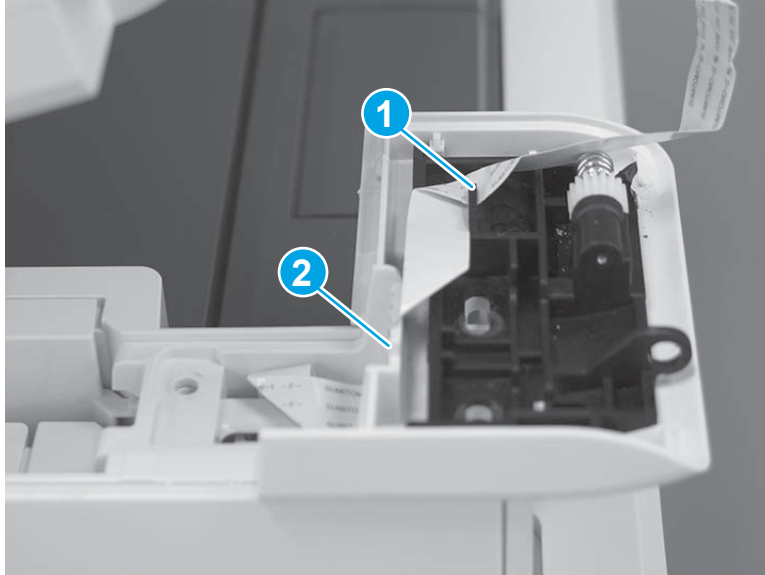

3. Remove the control panel mount base.

Figure 1-2168 Release the control panel mount base



Step 4: Remove the control panel mount chassis assembly (M427/M426)

1. Slide the mount chassis assembly as shown (callout 1) to release it from four bosses (callout 2).

Figure 1-2169 Release the mount chassis assembly

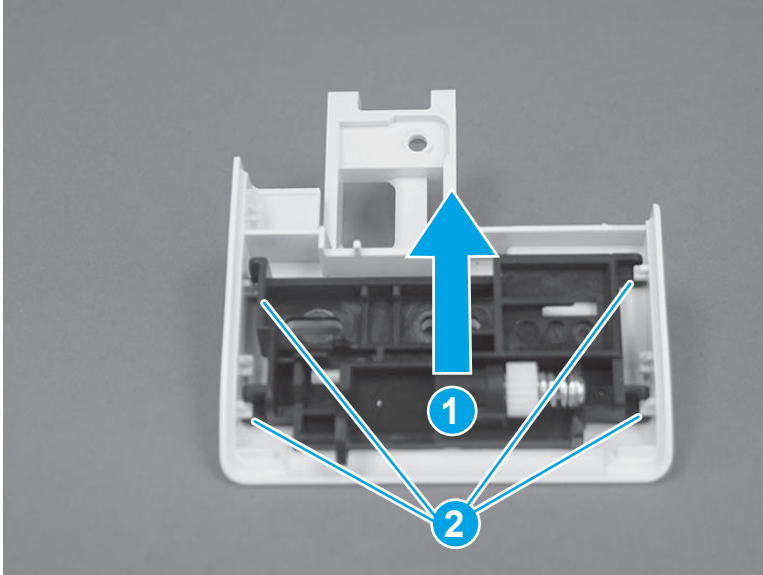

2. Separate the mount chassis assembly from the mount base.

Figure 1-2170 Remove the mount chassis assembly

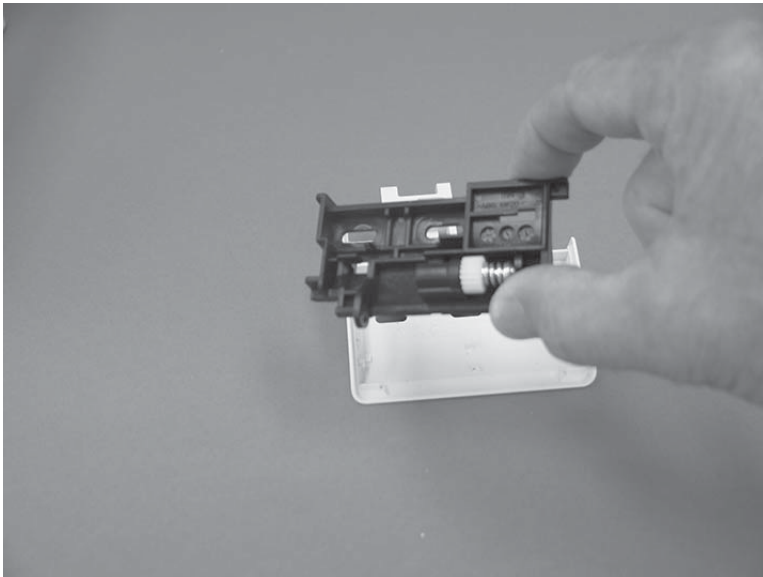

Step 5: Remove Tray 2



NOTE: If the 22-pin control panel FFC does not need to be removed and replaced, skip this step and go to [Step 9: Unpack the replacement assembly on page 1149](#).

- ▲ Pull the tray straight out of the printer to remove it.

Figure 1-2171 Remove the tray



Step 6: Remove the cartridge door assembly

 **NOTE:** If the 22-pin control panel FFC does not need to be removed and replaced, skip this step and go to [Step 9: Unpack the replacement assembly on page 1149](#).

 **NOTE:** If the toner cartridge was not removed prior to servicing the printer, remove it now.

1. Release one tab (callout 1), and then slide shaft (callout 2) in the direction the arrow indicates and remove it.

 **TIP:** It might be easier to release the support shaft by using a small flat-blade screwdriver.

Figure 1-2172 Release the support shaft

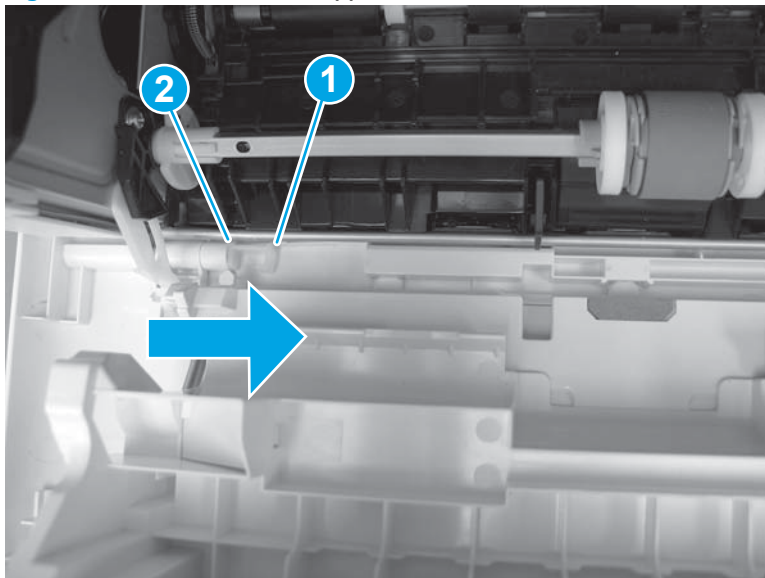

2. Release one tab (callout 1), and then slide the guide (callout 2) in the direction the arrow indicates and remove it.

Figure 1-2173 Remove the guide

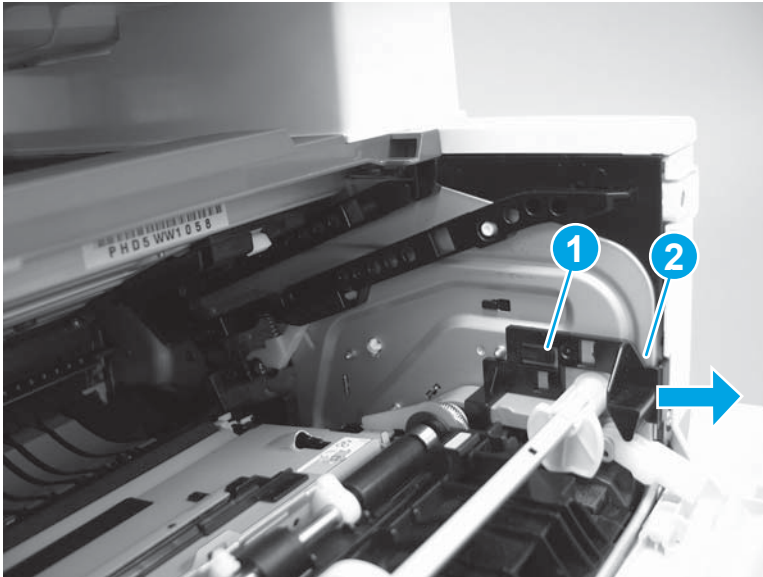

3. Remove the link arm (callout 1).

Figure 1-2174 Remove the link arm

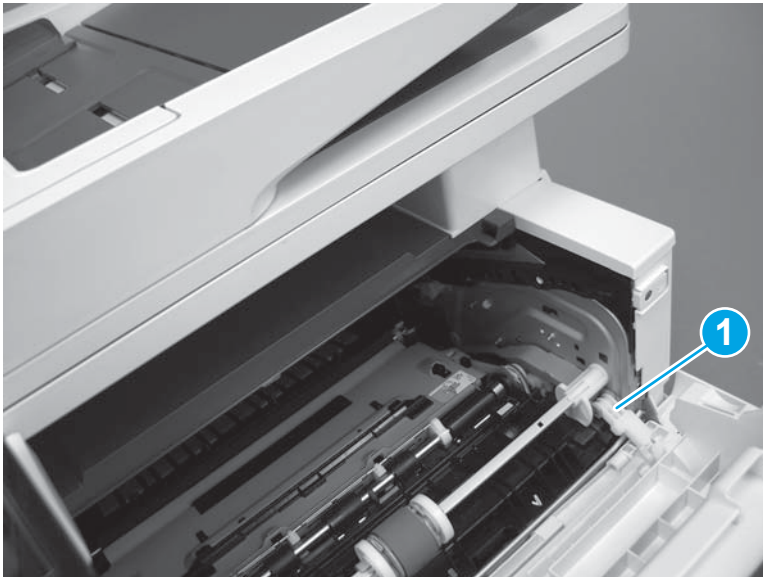

4. Slide the cartridge door assembly (callout 1) in the direction the arrow indicates and remove it.

Figure 1-2175 Remove the door

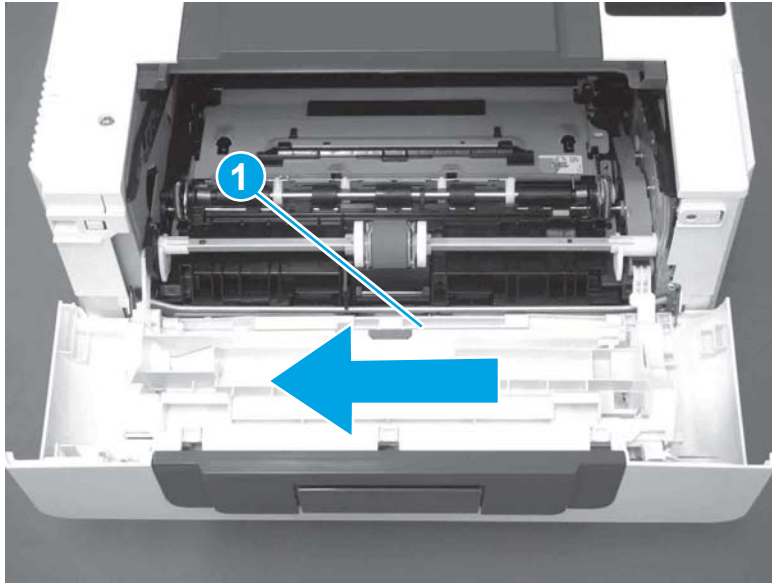

5. Remove the link (callout 1) from the cartridge door assembly (callout 2).

Figure 1-2176 Release the left-side retainer arm

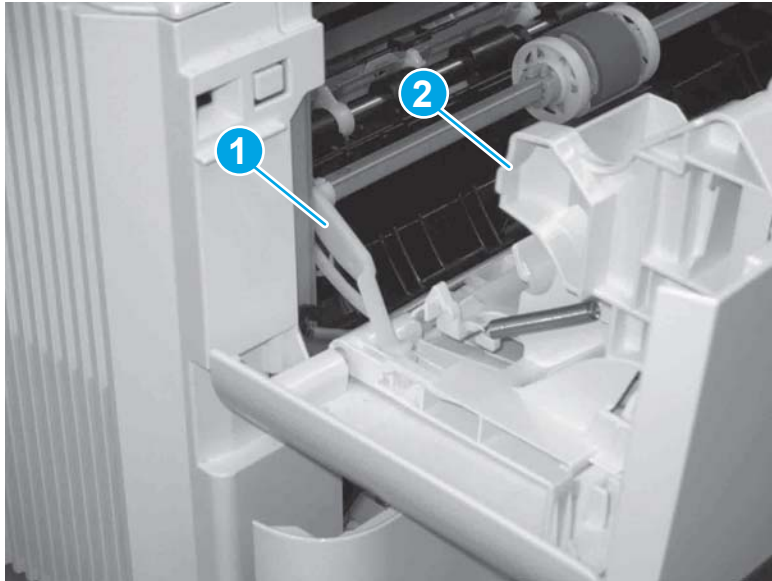

Step 7: Remove the left cover

 **NOTE:** If the 22-pin control panel FFC does not need to be removed and replaced, skip this step and go to [Step 9: Unpack the replacement assembly on page 1149.](#)

1. Remove one screw (callout 1).

Figure 1-2177 Remove one screw

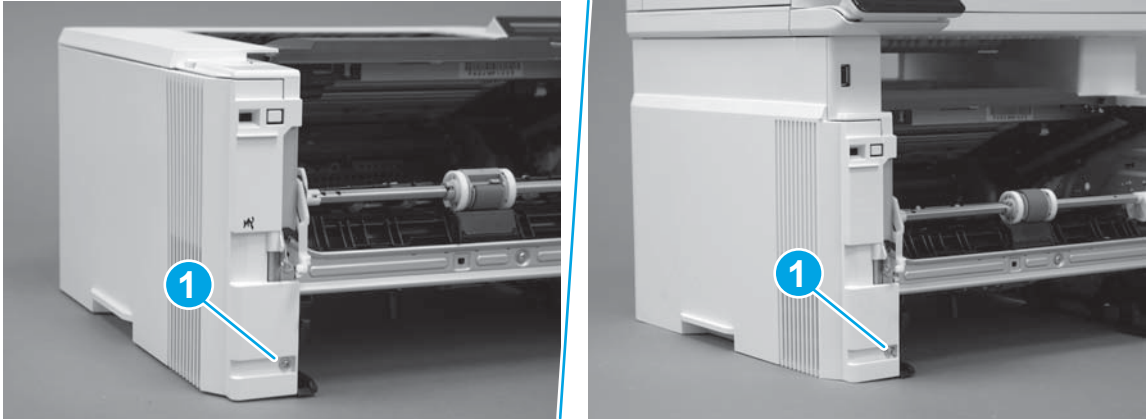

2. Open the rear door, release two bosses (callout 1), and then release three tabs (callout 2).

Figure 1-2178 Release two bosses and three tabs

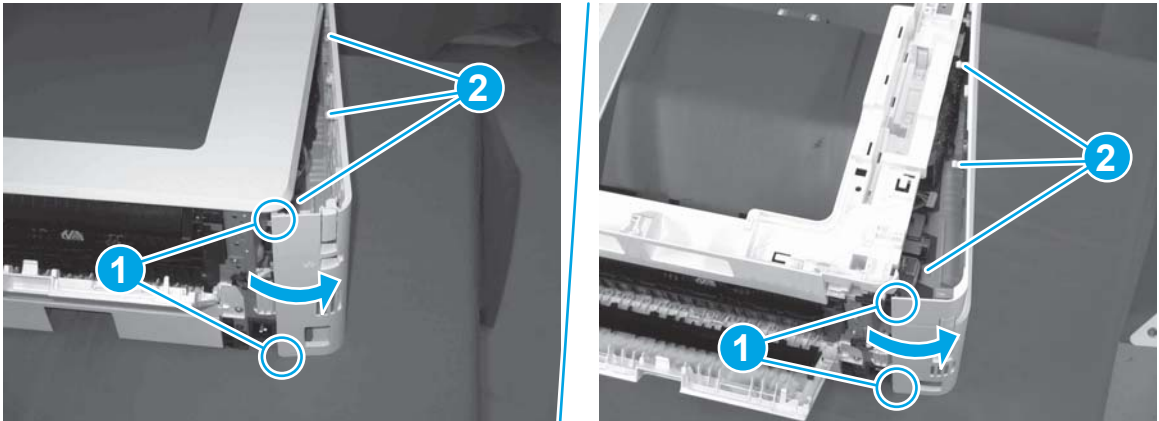

3. At the front of the printer, do one of the following:
 - **M403/M402:** Release two bosses (callout 1), and then remove the cover (callout 2).
 - **M427/M426:** Release one tab (callout 3), two bosses (callout 4), and then remove the cover (callout 5).

CAUTION: Be careful when releasing the upper bosses on the M427/M426 cover. One portion of the cover (callout 6) is fragile and is easily broken.

Figure 1-2179 Remove the cover

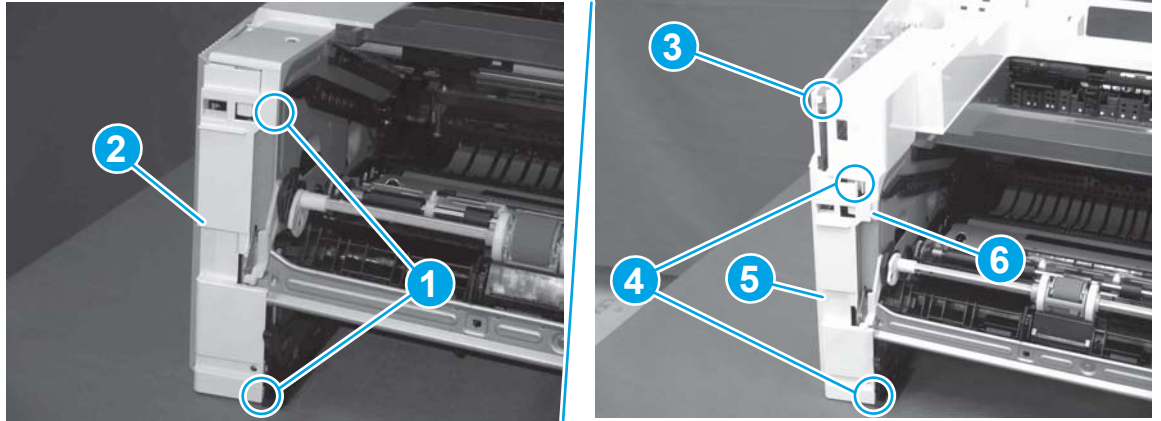

Step 8: Remove the control panel 22-pin FFC (M427/M426)

 **NOTE:** If the 22-pin control panel FFC does not need to be removed and replaced, skip this step and go to [Step 9: Unpack the replacement assembly on page 1149](#).

1. Release the ISA flat-flexible cable (FFC) cover (callout 1), and then remove it (callout 2).

Figure 1-2180 Remove the ISA FFC cover

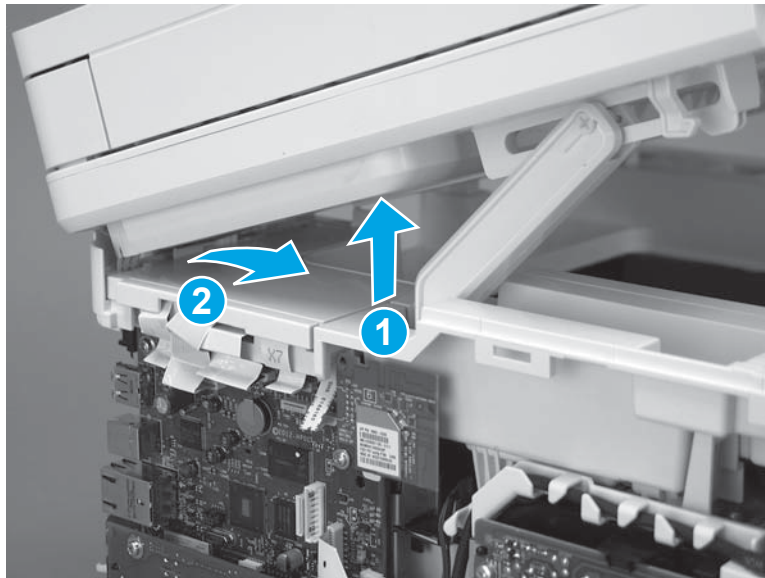

2. Disconnect one FFC (callout 1).

Figure 1-2181 Disconnect one FFC

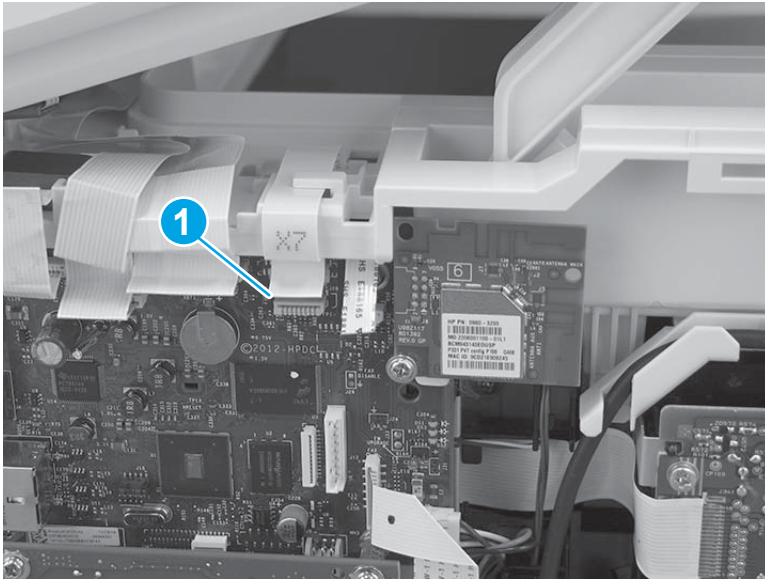

3. Lift up the control-panel FFC cover to release it.

Figure 1-2182 Release the control-panel FFC cover

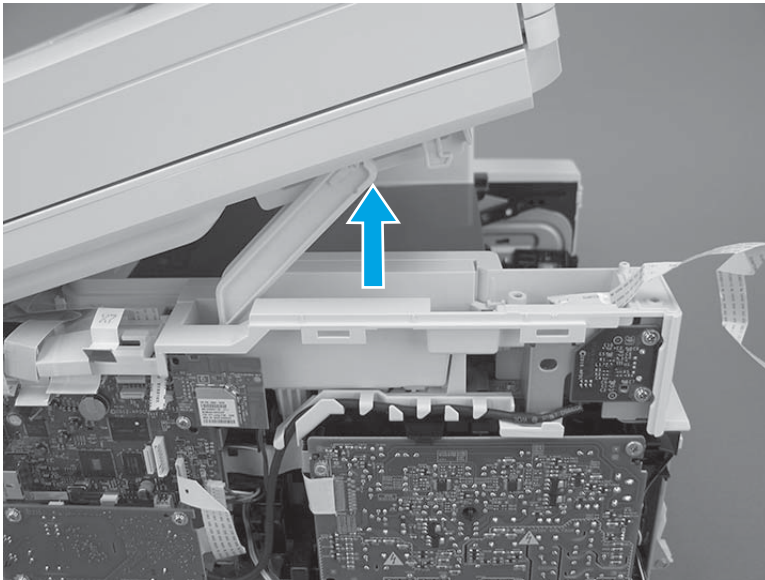

4. Remove the cover and FFC.

Figure 1-2183 Remove the cover and FFC

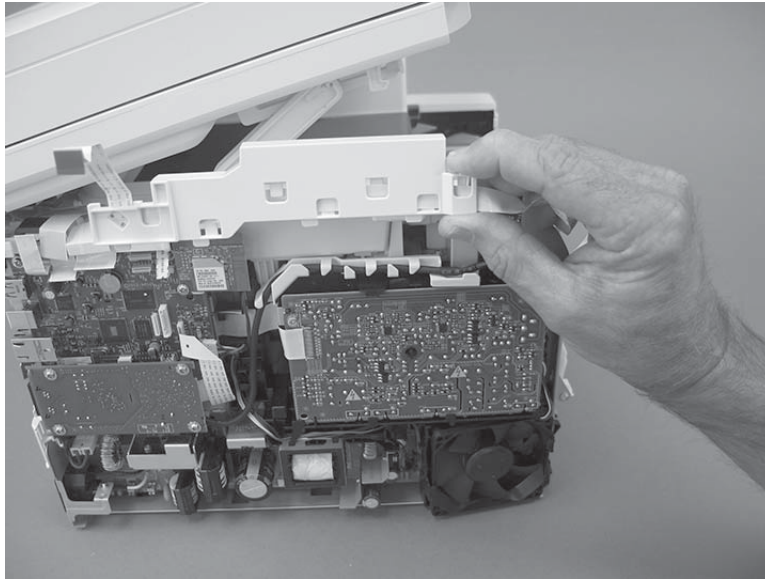

5. Release the FFC from the retainers (callout 1) on the cover to remove it.

 **Reinstallation tip:** Take note of how the FFC is installed on the cover. Make sure that the replacement FFC is installed with the pre-folds in the FFC correctly positioned to reach the formatter and the control panel.

Figure 1-2184 Remove the FFC



Step 9: Unpack the replacement assembly

Unpack the replacement part from the packaging.

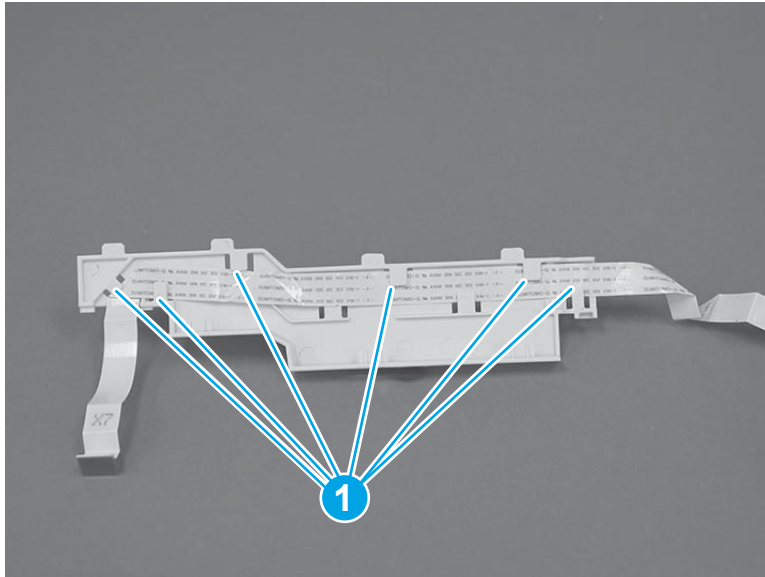
 **NOTE:** Unpack the appropriate assembly that is being replaced. The control panel is shown below.

<http://www8.hp.com/us/en/hp-information/environment/product-recycling.html>

 **NOTE:** HP recommends responsible disposal of the defective part.

Figure 1-2185 Recycle and unpack

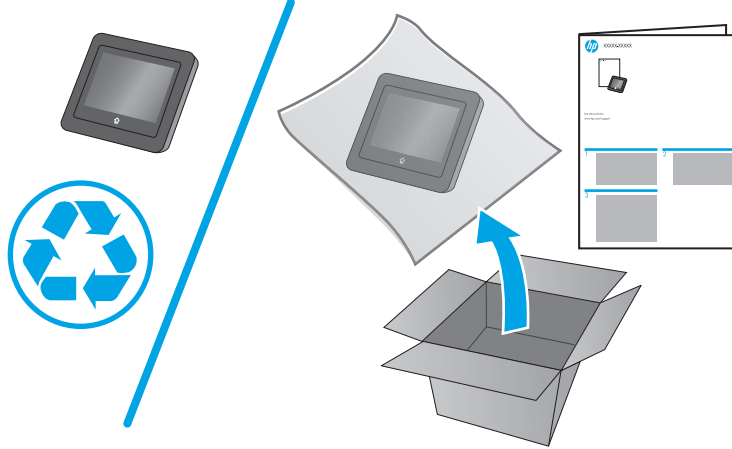

Step 10: Install the control panel 22-pin FFC (M427/M426)

 **NOTE:** If the 22-pin control panel FFC does not need to be removed and replaced, skip this step and go to [Step 14: Install the control panel mount chassis assembly \(M427/M426\) on page 1157.](#)

1. Install the FFC in the retainers (callout 1) on the control-panel FFC.

 **Reinstallation tip:** Make sure that the replacement FFC is installed with the pre-folds in the FFC correctly positioned to reach the formatter and the control panel.

Figure 1-2186 Install the FFC on the cover



2. Position the cover on the printer, and then push down to install it.

Figure 1-2187 Install the cover

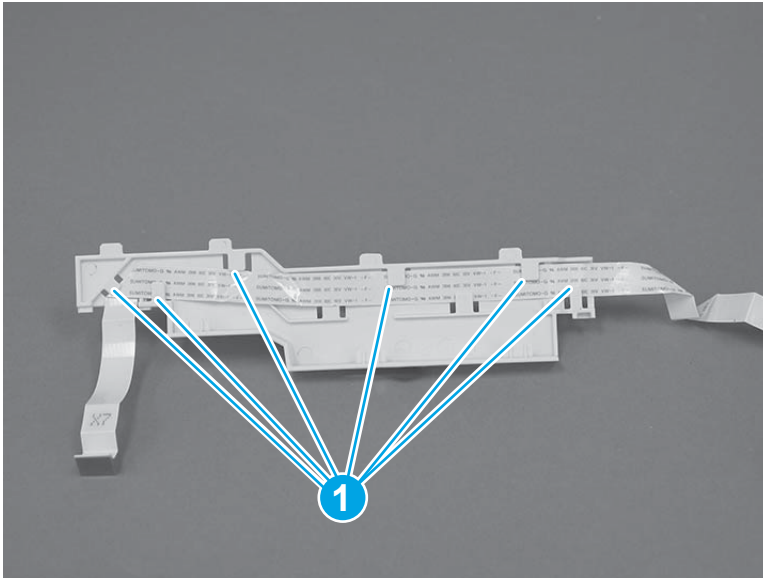
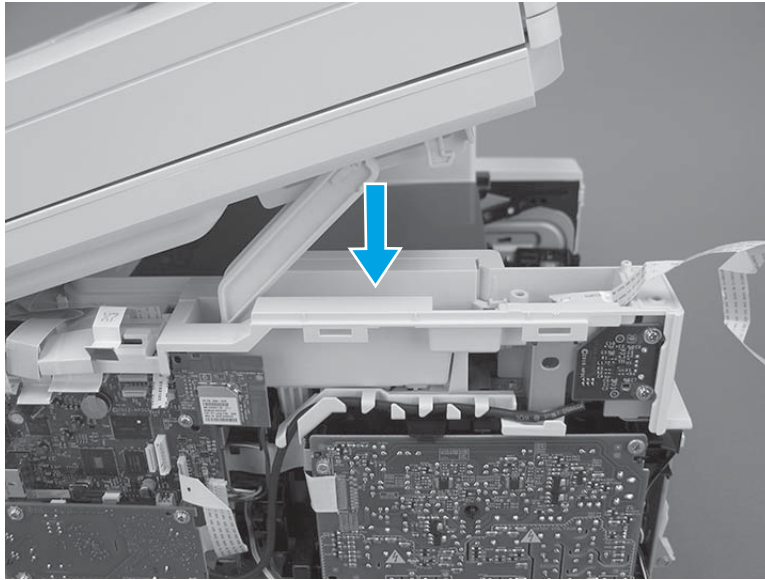

3. Connect one FFC (callout 1).

Figure 1-2188 Connect one FFC

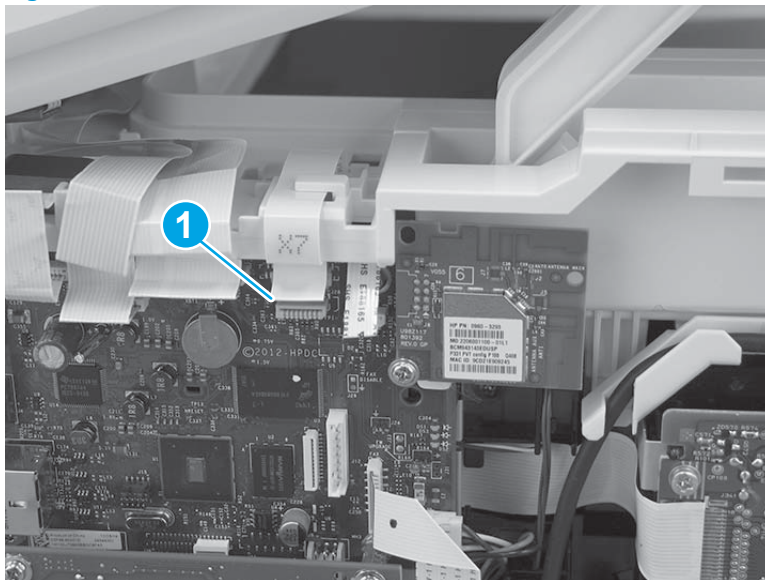

4. Position the rear edge of the ISA flat-flexible cable (FFC) cover on the printer (callout 1), and then rotate it down (callout 2) until it snaps into place.

Figure 1-2189 Install the ISA FFC cover

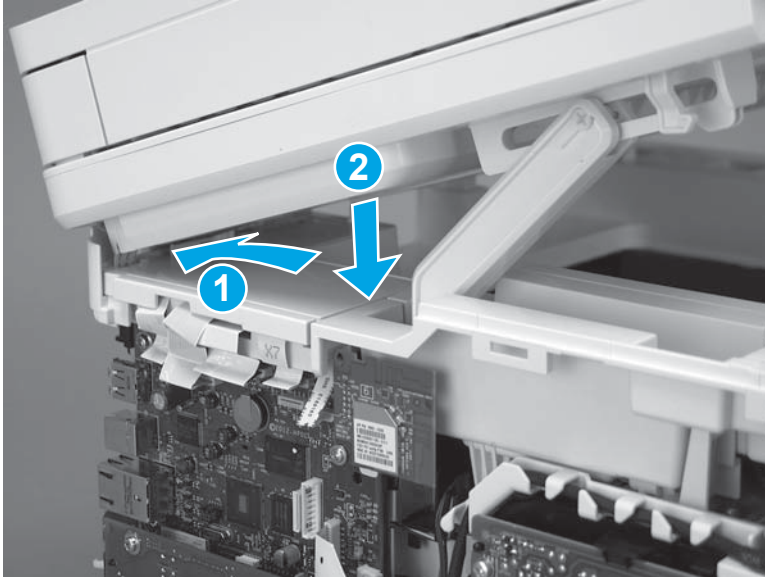

Step 11: Install the left cover

 **NOTE:** If the 22-pin control panel FFC was not replaced, skip this step and go to [Step 14: Install the control panel mount chassis assembly \(M427/M426\) on page 1157](#).

1. At the front of the printer, do one of the following:
 - **M403/M402:** Position the cover on the printer (callout 1), and then engage two bosses (callout 2).
 - **M427/M426:** Position the cover on the printer (callout 3), engage one tab (callout 4), and then engage two bosses (callout 5).

Figure 1-2190 Install the cover

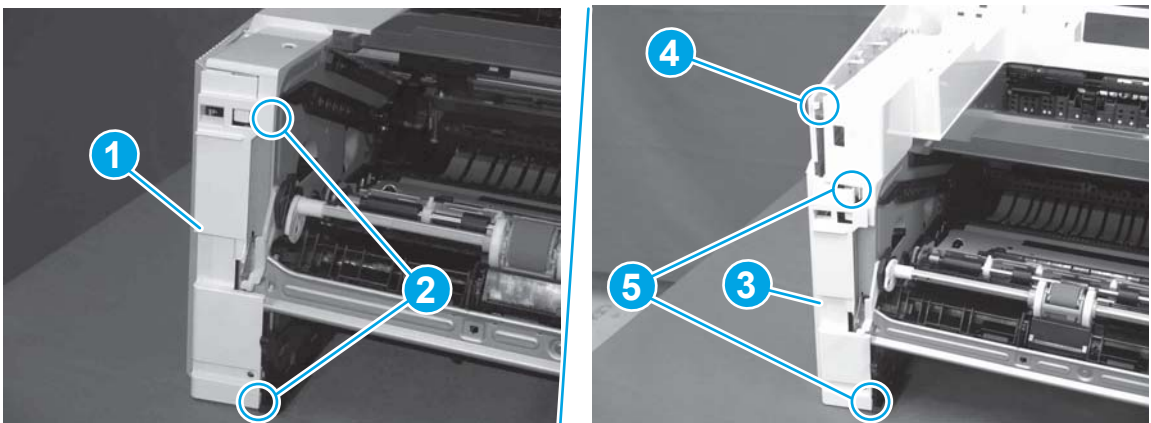

2. Carefully rotate the rear of the cover onto the printer (callout 1), engage three tabs (callout 2), and then engage two bosses (callout 3).

Figure 1-2191 Engage three tabs and two bosses

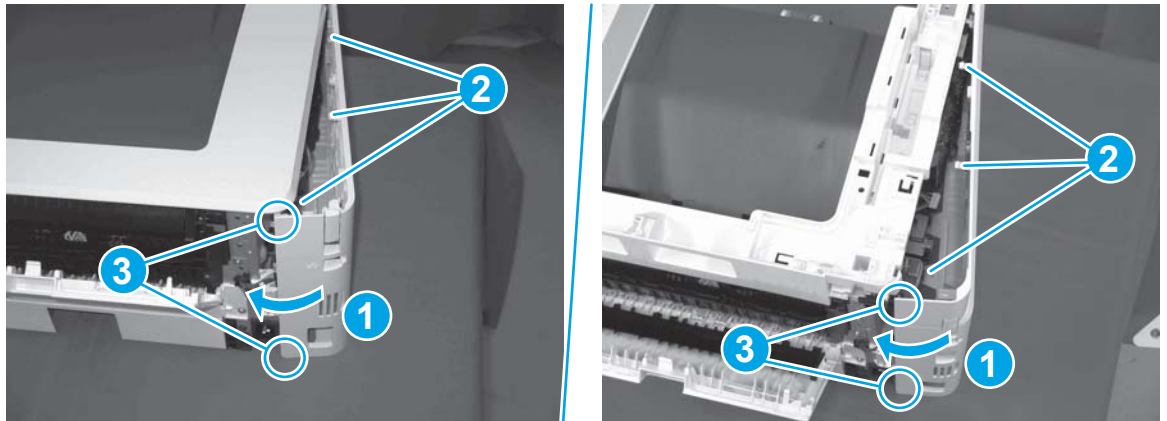

3. Install one screw (callout 1).

Figure 1-2192 Install one screw

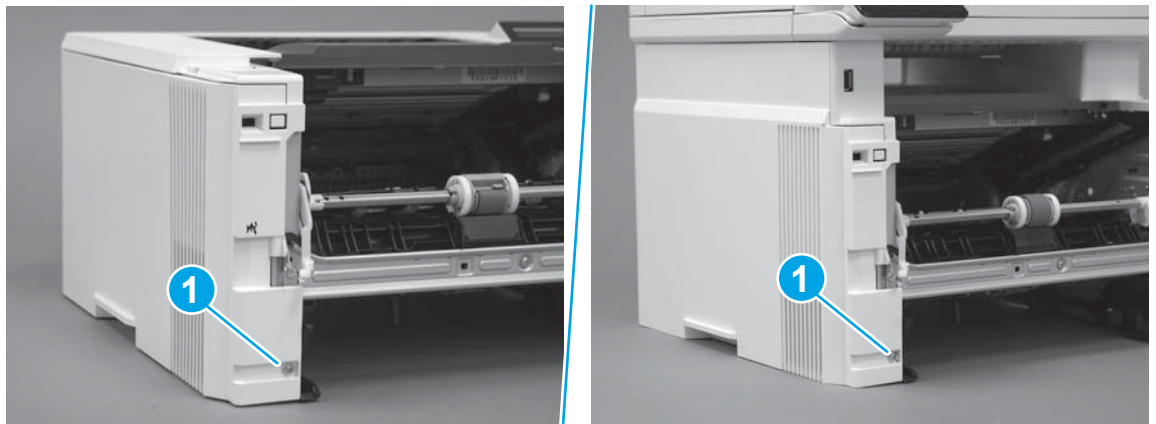

Step 12: Install the cartridge door assembly

 **NOTE:** If the 22-pin control panel FFC was not replaced, skip this step and go to [Step 14: Install the control panel mount chassis assembly \(M427/M426\)](#) on page 1157.

 **Reinstallation tip:** After a replacement door is installed, make sure to install the nameplate (supplied in the kit) corresponding to the printer name on the door.

1. Position the door close to the printer, and then engage the keyed pin on the left-side retainer arm with the hole in the door.

Figure 1-2193 Engage the left-side retainer arm

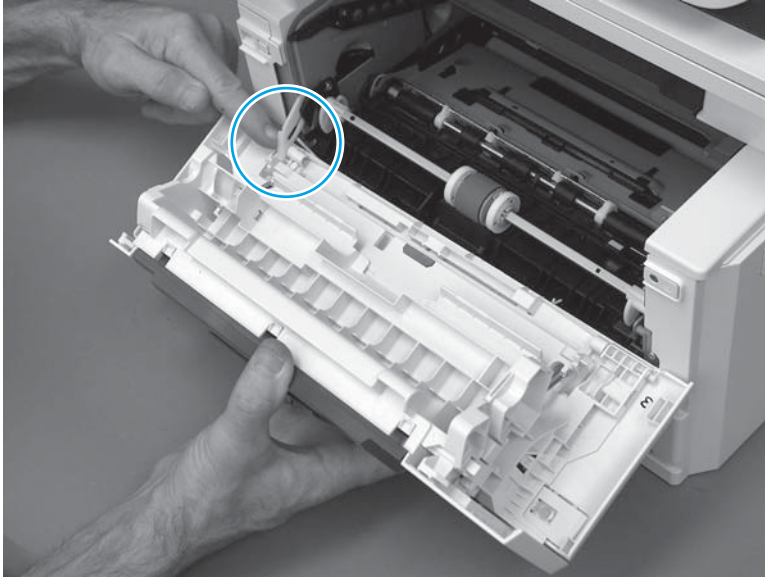

2. Engage the right-side door hinge pin with the hole in the chassis (callout 1).

Figure 1-2194 Install the door

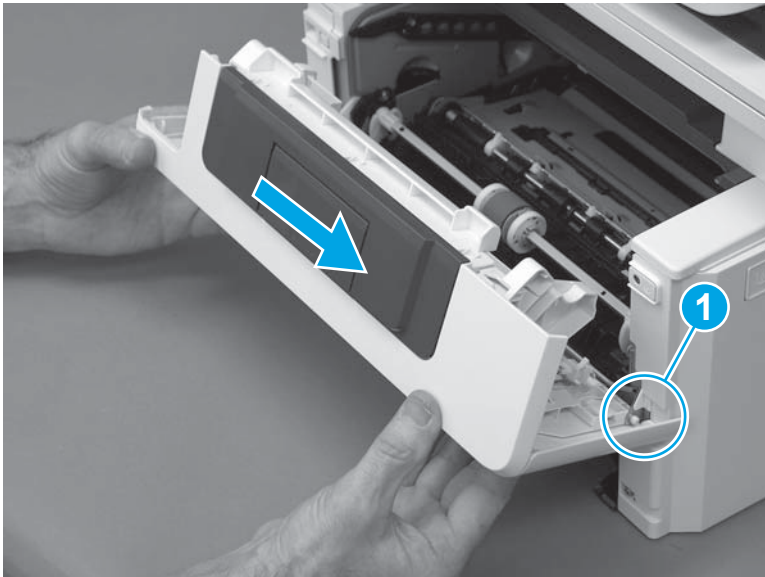

3. Install the link (callout 1).

 **IMPORTANT:** Make sure that the link snaps into place on the arm (callout 2). The link actuates the fuser pressure-release mechanism.

Figure 1-2195 Install the pressure-release link

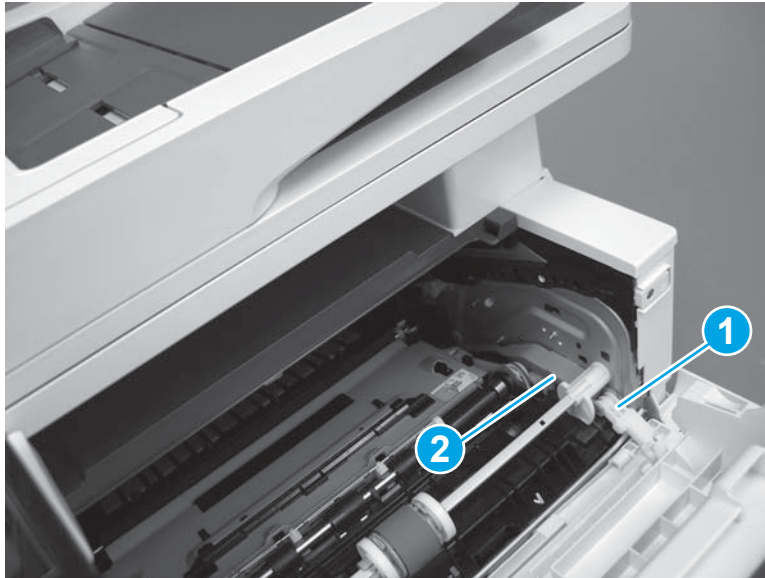

4. Slide the guide into the printer (callout 1), and then make sure that the tab (callout 2) snaps into place to secure the guide to the chassis.

Figure 1-2196 Install the guide

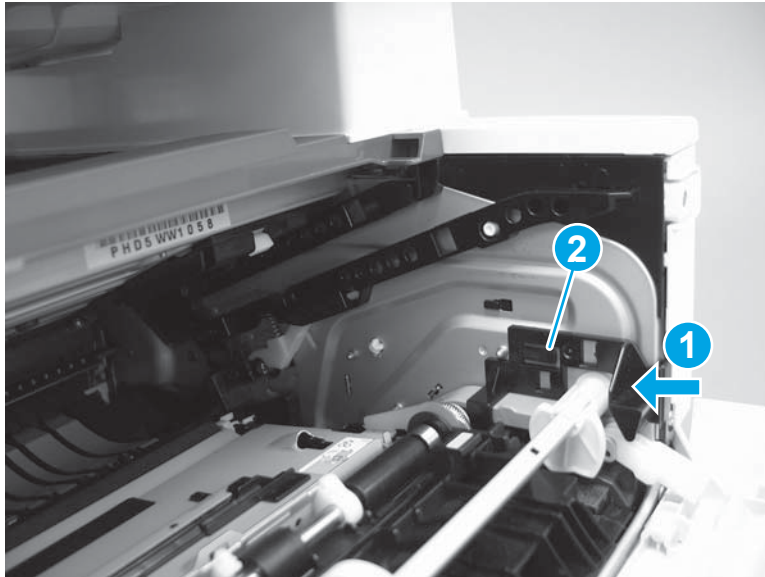

5. Position the shaft on the door, and then align the left-side hinge on the door with the hole in the chassis (callout 1).

Figure 1-2197 Align the hinge

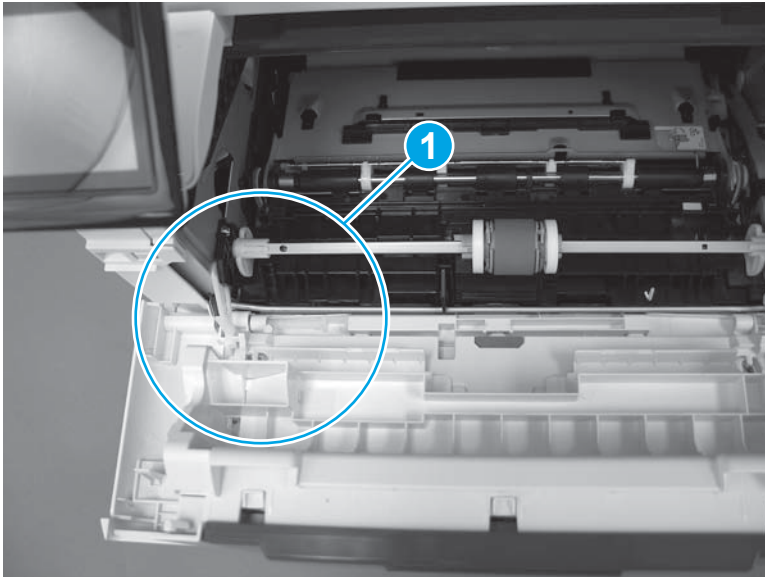

6. Push the shaft towards the left side of the printer to install it (callout 1).

 **Reinstallation tip:** Make sure that the support shaft is fully installed and correctly orientated (callout 2) so that it will not interfere with the door opening and closing.

Figure 1-2198 Install the support shaft



Step 13: Install Tray 2

 **NOTE:** If the 22-pin control panel FFC was not replaced, skip this step and go to [Step 14: Install the control panel mount chassis assembly \(M427/M426\) on page 1157](#).

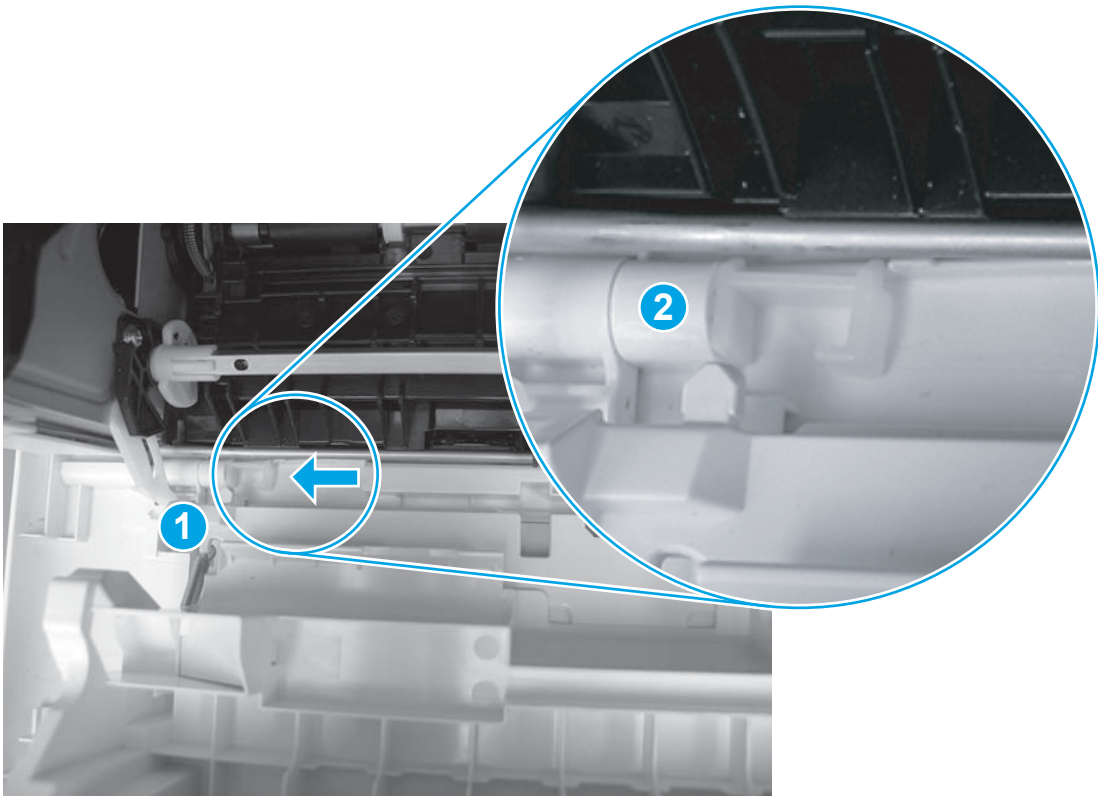
- ▲ Slide the tray straight into the printer to install it.

Figure 1-2199 Install the tray



Step 14: Install the control panel mount chassis assembly (M427/M426)

1. Position the mount chassis assembly on the mount base.

Figure 1-2200 Install the mount chassis assembly

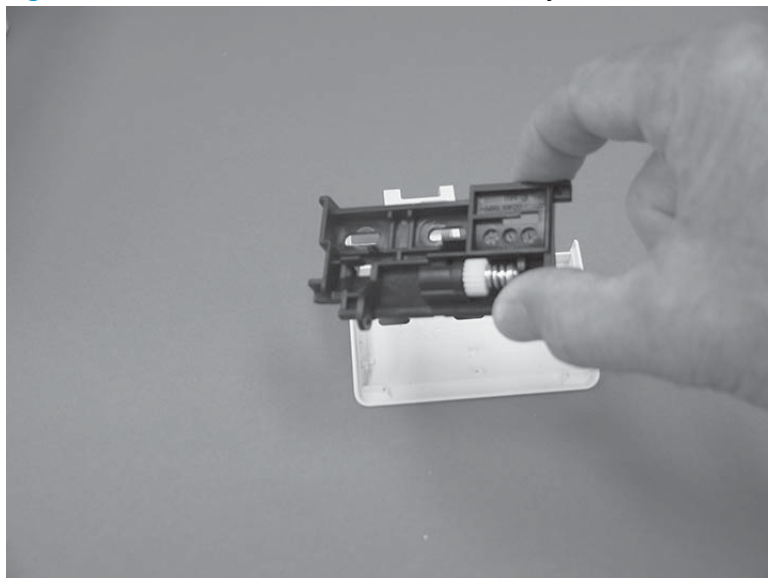

2. Slide the mount chassis assembly as shown (callout 1) to engage it with four bosses (callout 2) on the mount base.

Figure 1-2201 Release the mount chassis assembly

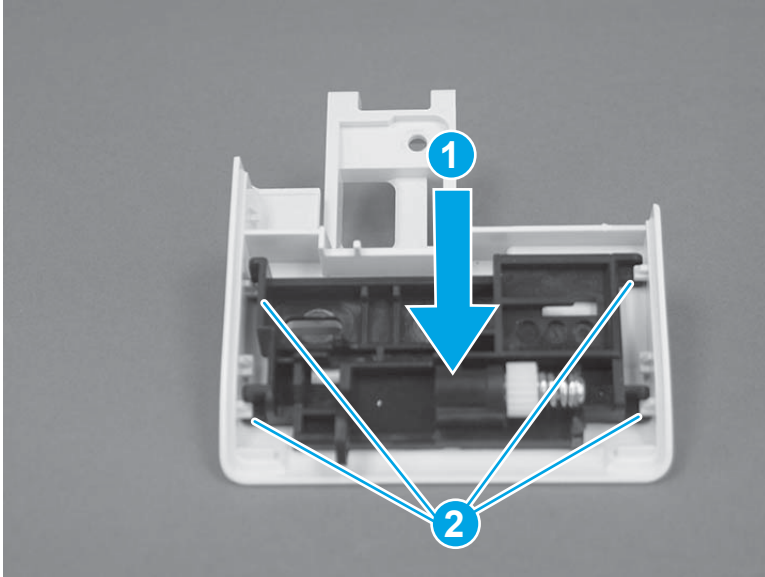

Step 15: Install the control panel mount base (M427/M426)

1. Install the control panel mount base on the printer.

Figure 1-2202 Install the control panel mount base



2. Install two screws (callout 1).

Figure 1-2203 Install two screws

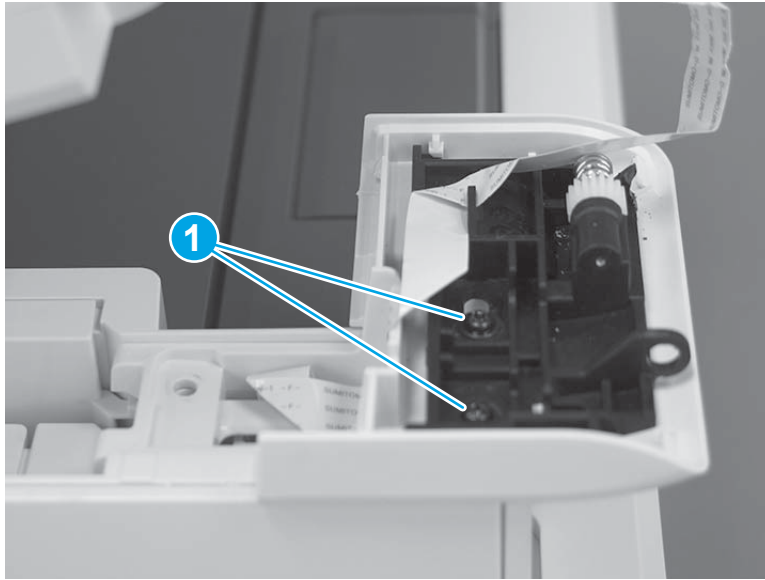

3. Install the FFC in the retainer (callout 1).

 **NOTE:** Remove the protective film from the two-sided tape on the replacement FFC to expose the sticky side of the tape.

Make sure to press the FFC against the mount base (callout 2) to adhere it to the mount base.

Figure 1-2204 Install the FFC

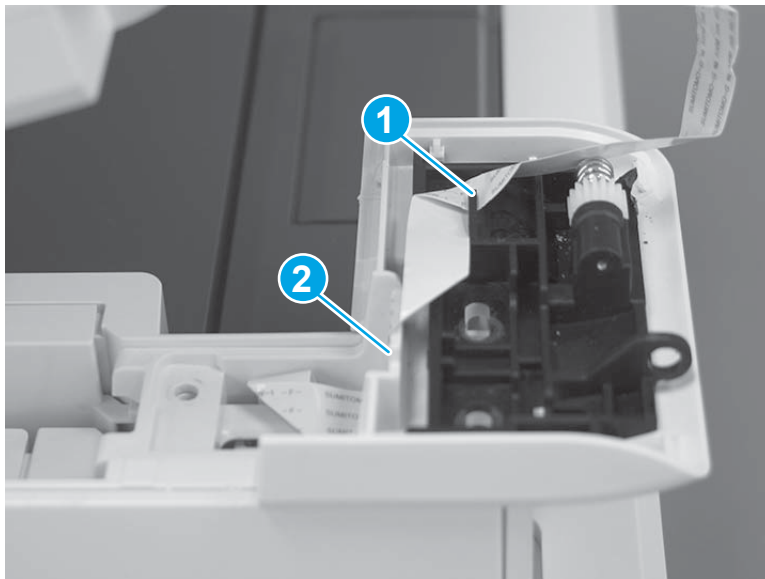

Step 16: Install the control panel (M427/M426)

1. Insert the FFC in the connector (the contact portion of the FFC must face towards the PCA), and then close the latch to secure it.

 **CAUTION:** Be careful. Do not dislodge the latch from the connector.

 **Reinstallation tip:** Gently pull on the FFC to make sure it is fully seated and secured by the latch on the connector. Do not forcibly pull on the FFC, a gentle tug is all that is required.

Figure 1-2205 Connect the FFC



2. Align the control-panel hinge pins (callout 1) with the mounting retainers (callout 2) on the printer.

Figure 1-2206 Align the control-panel hinge pins

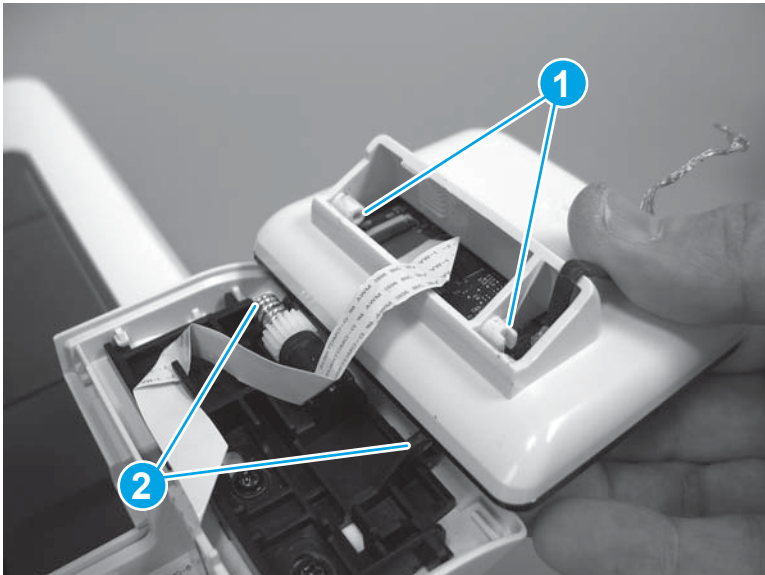

3. Slightly shift the control panel in the direction of the arrow about 6.35 mm (.25 in) to engage the hinge pins.

⚠ CAUTION: Do not twist the control panel. The black-plastic mounting retainer (callout 1) for the control-panel hinge pin is easily broken

Figure 1-2207 Engage the control panel

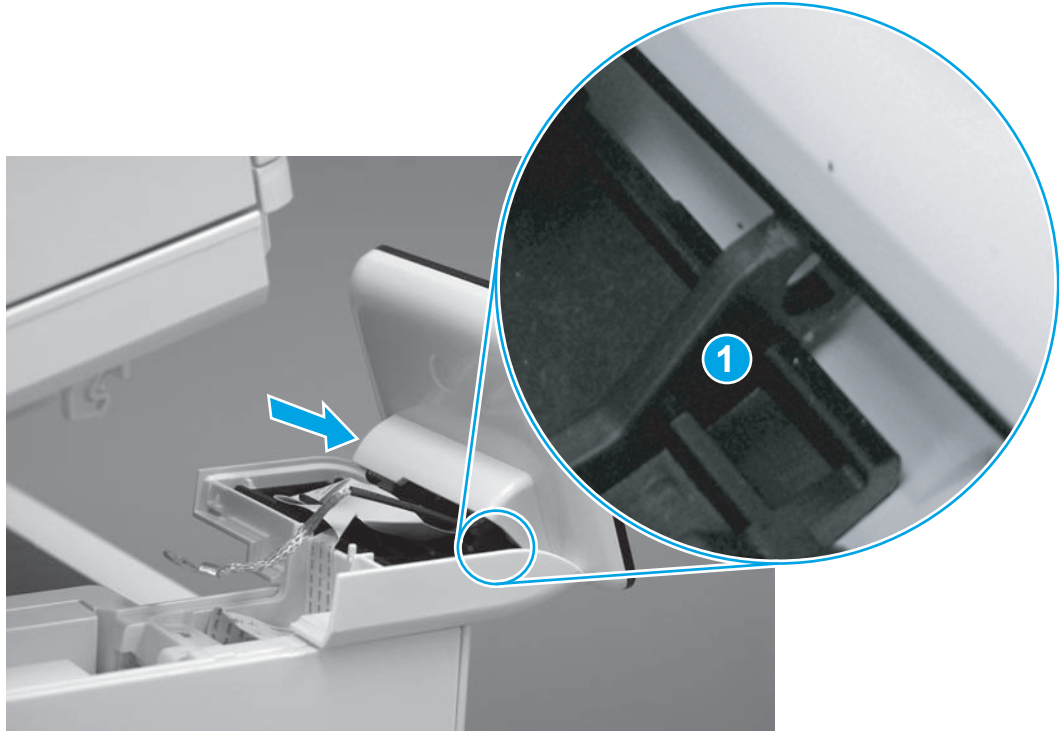

4. With the hinge pins engaged, gently tilt the control panel backward about 3.18 mm (.125 in).

⚠ CAUTION: Do not use excessive force. The black-plastic mounting retainer (callout 1) for the control-panel hinge pin is easily broken

Figure 1-2208 Tilt the control-panel assembly backward

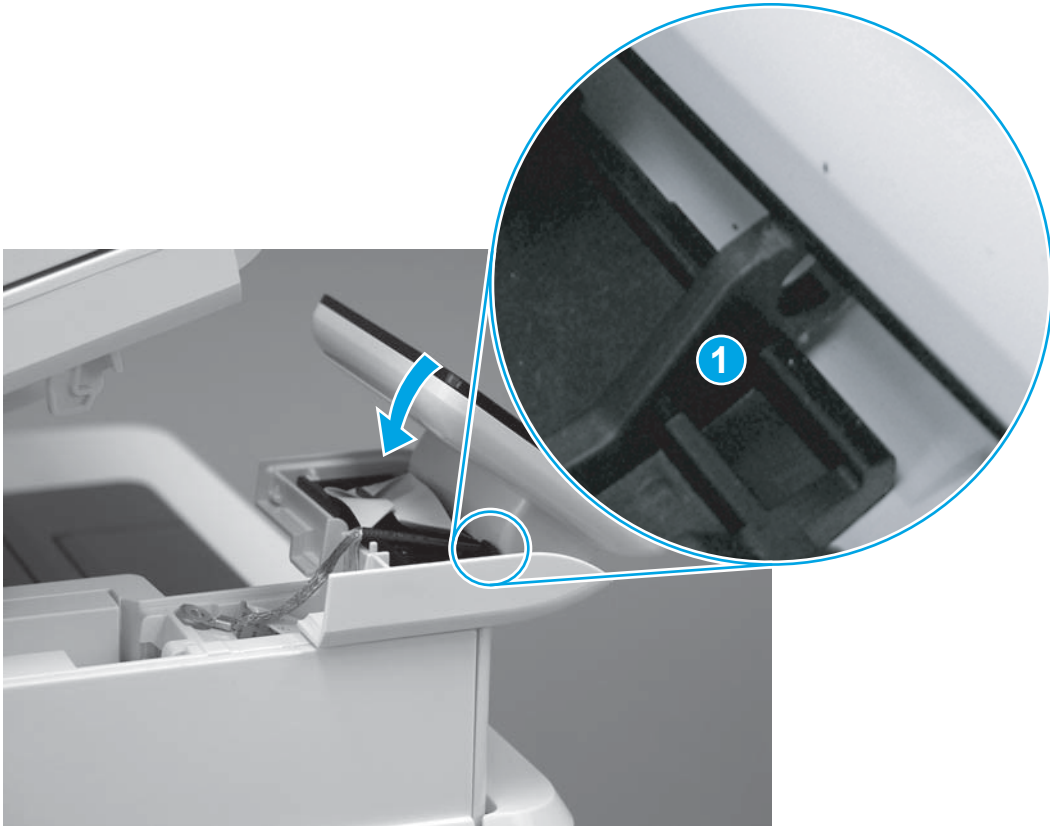

5. Install one ground screw (callout 1).

Figure 1-2209 Install one screw

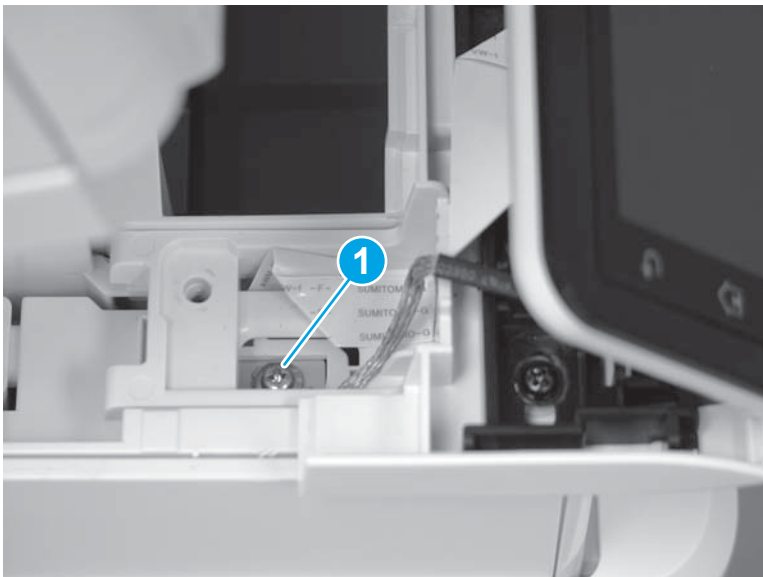

Step 17: Install the control panel mount cover (M427/M426)

1. Position the front edge of the control-panel cable cover at the base of the control panel (callout 1), and then rotate it down to install it (callout 2).

Figure 1-2210 Install the control-panel cable cover



2. Make sure that the two tabs (callout 1) on the cover snap into place.

Figure 1-2211 Check two tabs



3. Install one screw (callout 1).

Figure 1-2212 Install one screw

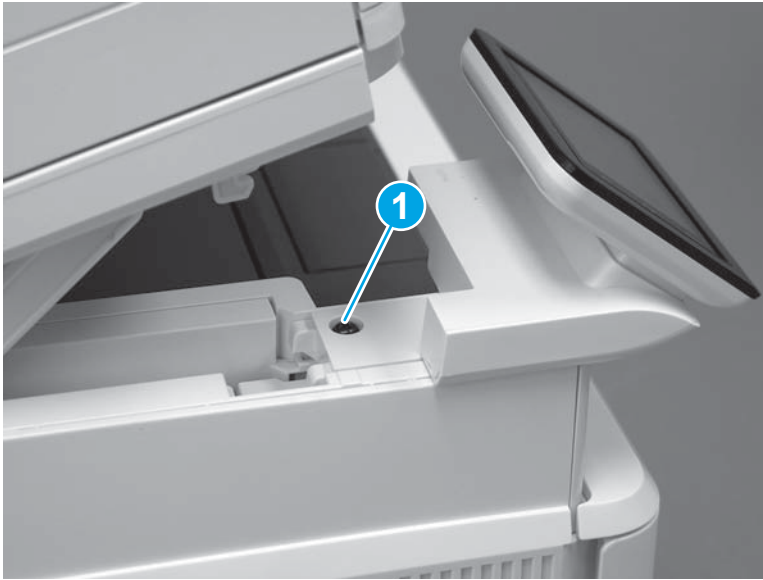

4. Close the ISA.

Figure 1-2213 Close the ISA



Removal and replacement: Trays

- [Removal and replacement: Tray 2](#)

Removal and replacement: Tray 2

- [RM2-5392-000CN 250-sheet paper input tray](#)
- [RM2-5452-000CN Tray 2 paper pickup roller assembly](#)
- [RM2-5397-000CN Tray 2 separation roller assembly](#)

RM2-5392-000CN 250-sheet paper input tray

- [Introduction](#)
- [Step 1: Remove Tray 2](#)
- [Step 2: Unpack the replacement assembly](#)
- [Step 3: Install Tray 2](#)

Introduction

This document provides the procedures to remove and replace Tray 2.

Before performing service

Turn the printer power off

- Disconnect the power cable.

 **WARNING!** To avoid damage to the printer, turn the printer off, wait 30 seconds, and then remove the power cable before attempting to service the printer.

Use the table below to identify the correct part number for your printer. To order the part, go to www.hp.com/buy/parts.

Tray 2 part number	
RM2-5392-000CN	Cassette (Tray 2) assembly

Required tools

- No special tools are required to remove this part.

After performing service

Turn the printer power on

- Connect the power cable.
- Use the power switch to turn the power on.

Post service test

Make sure that the printer initializes to a **Ready** state.

Print a configuration page (from Tray 2) to make sure that the printer is functioning correctly.

Step 1: Remove Tray 2

- ▲ Pull the tray straight out of the printer to remove it.

Figure 1-2214 Remove the tray



Step 2: Unpack the replacement assembly

Unpack the replacement part from the packaging.

<http://www8.hp.com/us/en/hp-information/environment/product-recycling.html>

 **NOTE:** HP recommends responsible disposal of the defective part.

Figure 1-2215 Recycle and unpack

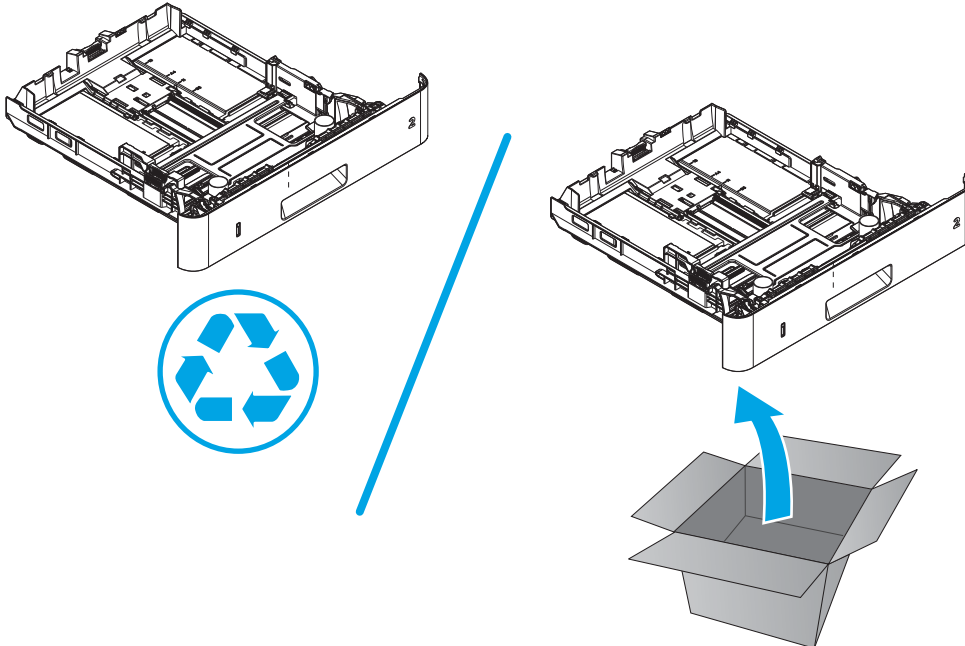

Step 3: Install Tray 2

- ▲ Slide the tray straight into the printer to install it.

Figure 1-2216 Install the tray



RM2-5452-000CN Tray 2 paper pickup roller assembly

- [Introduction](#)
- [Step 1: Remove Tray 2](#)
- [Step 2: Remove the pickup roller assembly \(Tray 2\)](#)
- [Step 3: Unpack the replacement assembly](#)
- [Step 4: Install the pickup roller assembly \(Tray 2\)](#)
- [Step 5: Install Tray 2](#)

Introduction

This document provides the procedures to remove and replace the paper pickup roller assembly (Tray 2).

Before performing service

Turn the printer power off

- Disconnect the power cable.

⚠ WARNING! To avoid damage to the printer, turn the printer off, wait 30 seconds, and then remove the power cable before attempting to service the printer.

Use the table below to identify the correct part number for your printer. To order the part, go to www.hp.com/buy/parts.

Paper pickup roller assembly (Tray 2) part number	
RM2-5452-000CN	Paper pickup roller assembly (Tray 2)

Required tools

- No special tools are required to remove this part.

After performing service

Turn the printer power on

- Connect the power cable.
- Use the power switch to turn the power on.

Post service test

Make sure that the printer initializes to a **Ready** state.

Print a page from Tray 2 to make sure that the printer is functioning correctly.

Step 1: Remove Tray 2

- ▲ Pull the tray straight out of the printer to remove it.

Figure 1-2217 Remove the tray



Step 2: Remove the pickup roller assembly (Tray 2)

CAUTION: When handling the roller holder, do not touch the gray spongy portion of the rollers. Skin oils on the rollers can cause paper handling problems.

NOTE: The M403/M402 printer is shown in this procedure. However, the procedure is valid for the M427/M426 printers.

1. Carefully rotate the printer backward.

CAUTION: To avoid damage to the rear cassette cover, keep it in the closed position.

Figure 1-2218 Tilt the printer backward

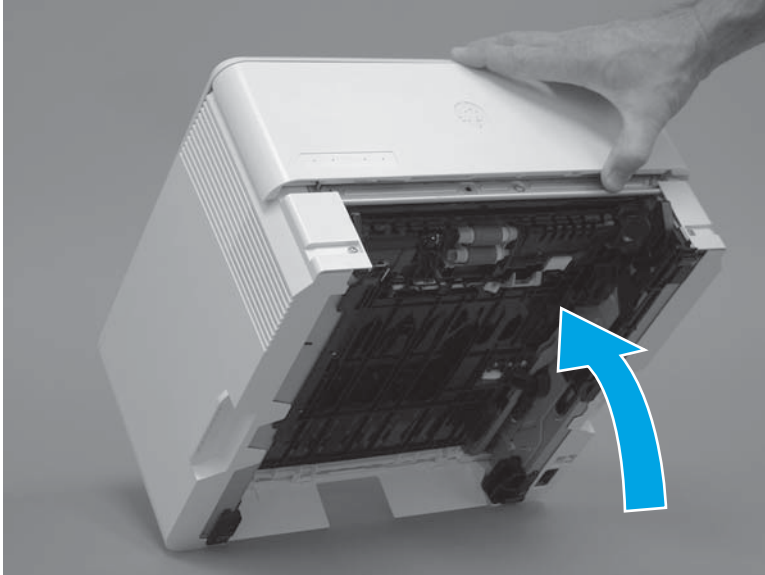

2. Continue rotate the printer backward until it rests on the rear cover, bottom-side face forward.

⚠ CAUTION: **M427/M426:** The integrated scanner assembly (ISA) is not captive, and can unexpectedly open when the printer is tilted back.

Figure 1-2219 Place the printer bottom-side face forward

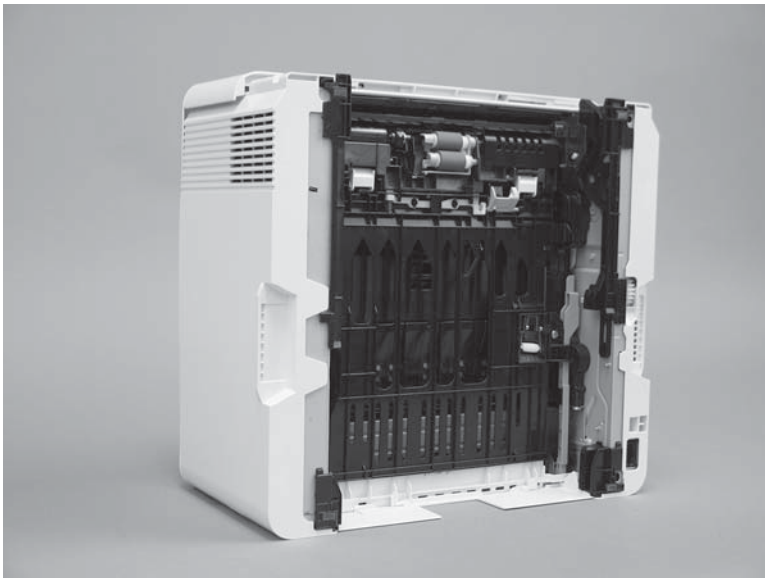

3. Release one tab (callout 1), and then slide the roller holder toward the left side of the printer to release it.

Figure 1-2220 Release one tab

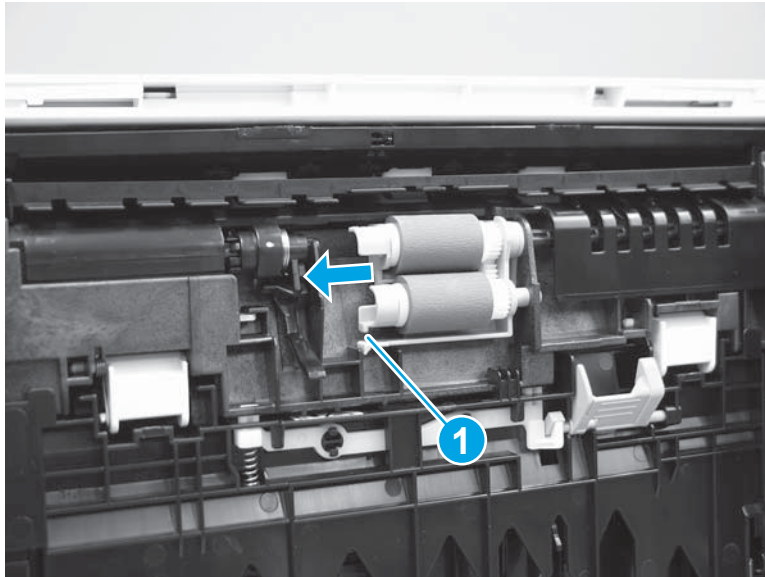

4. Remove the roller holder.

Figure 1-2221 Remove the roller holder

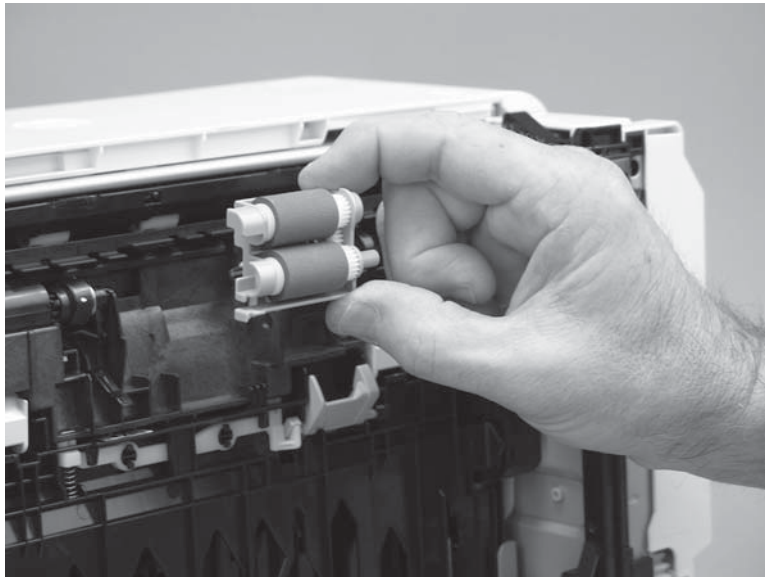

Step 3: Unpack the replacement assembly

Unpack the replacement part from the packaging.

<http://www8.hp.com/us/en/hp-information/environment/product-recycling.html>

CAUTION: When handling the roller holder, do not touch the gray spongy portion of the rollers. Skin oils on the rollers can cause paper handling problems.

NOTE: HP recommends responsible disposal of the defective part.

Figure 1-2222 Recycle and unpack

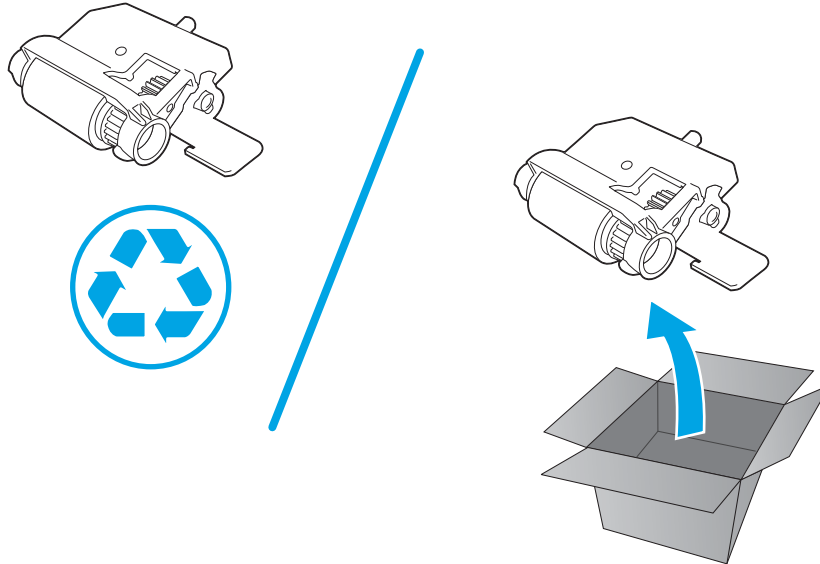

Step 4: Install the pickup roller assembly (Tray 2)

CAUTION: When handling the roller holder, do not touch the gray spongy portion of the rollers. Skin oils on the rollers can cause paper handling problems.

NOTE: The M403/M402 printer is shown in this procedure. However, the procedure is valid for the M427/M426 printers.

1. Position the roller holder assembly in the printer as shown, and then slide it toward the right side of the printer.

Figure 1-2223 Install the roller holder

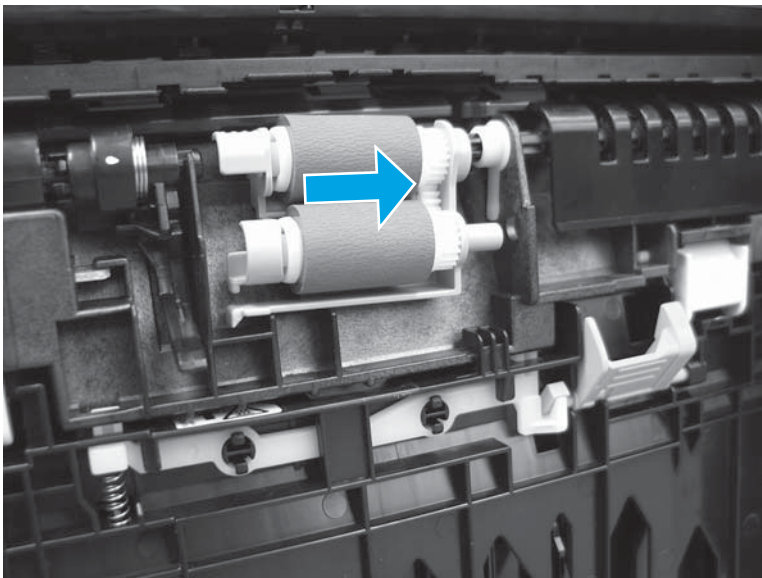

2. Make sure that the tab snaps into place.

Figure 1-2224 Check the tab

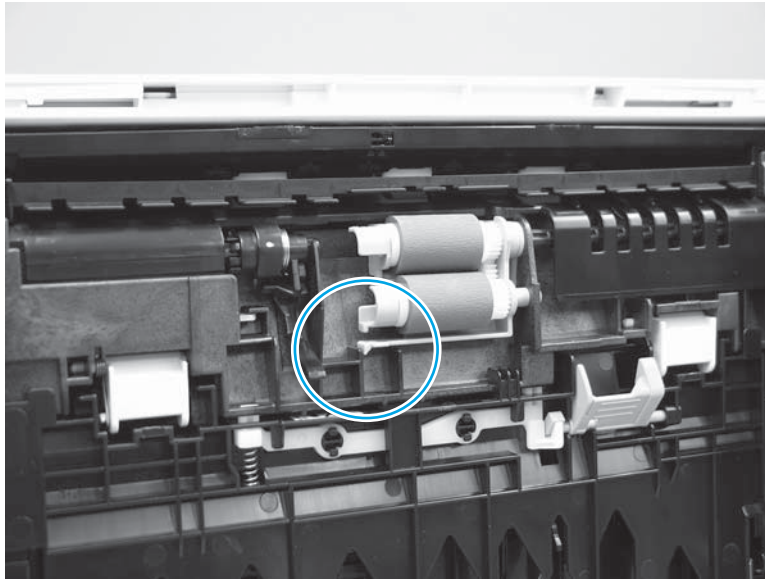

3. Carefully rotate the printer forward.

Figure 1-2225 Rotate the printer forward

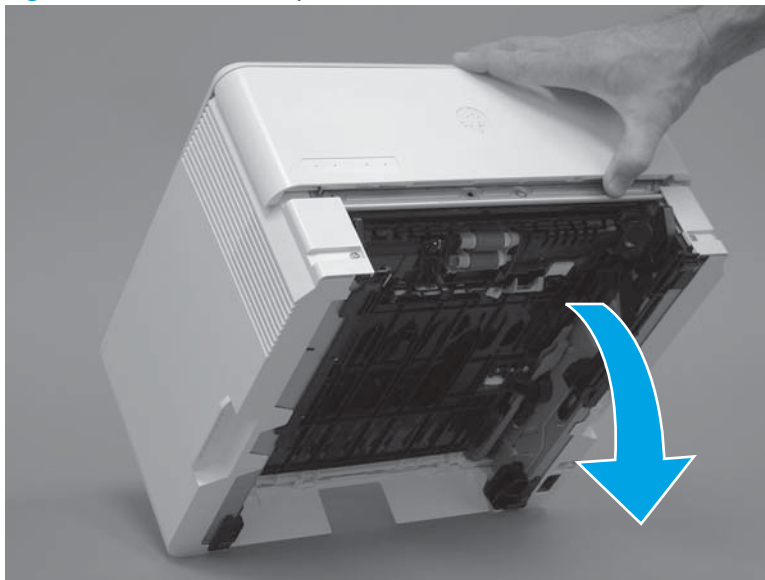

4. Continue rotate the printer forward until it rests in the operational position.

Figure 1-2226 Place the printer in the operational position



Step 5: Install Tray 2

- ▲ Slide the tray straight into the printer to install it.

Figure 1-2227 Install the tray



RM2-5397-000CN Tray 2 separation roller assembly

- [Introduction](#)
- [Step 1: Remove Tray 2](#)
- [Step 2: Remove the separation pad roller assembly \(Tray 2\)](#)
- [Step 3: Unpack the replacement assembly](#)
- [Step 4: Install the separation pad roller assembly \(Tray 2\)](#)
- [Step 5: Install Tray 2](#)

Introduction

This document provides the procedures to remove and replace the separation roller assembly (Tray 2).

Before performing service

Turn the printer power off

- Disconnect the power cable.

 **WARNING!** To avoid damage to the printer, turn the printer off, wait 30 seconds, and then remove the power cable before attempting to service the printer.

Use the table below to identify the correct part number for your printer. To order the part, go to www.hp.com/buy/parts.

Separation roller assembly (Tray 2) part number	
RM2-5397-000CN	Separation roller assembly (Tray 2)

Required tools

- No special tools are required to install this kit.

After performing service

Turn the printer power on

- Connect the power cable.
- Use the power switch to turn the power on.

Post service test

Make sure that the printer initializes to a **Ready** state.

Print a configuration page to make sure that the printer is functioning correctly.

Step 1: Remove Tray 2

- ▲ Pull the tray straight out of the printer to remove it.

Figure 1-2228 Remove the tray



Step 2: Remove the separation pad roller assembly (Tray 2)

1. Pull the separation pad assembly straight up to release it.

Figure 1-2229 Release the assembly

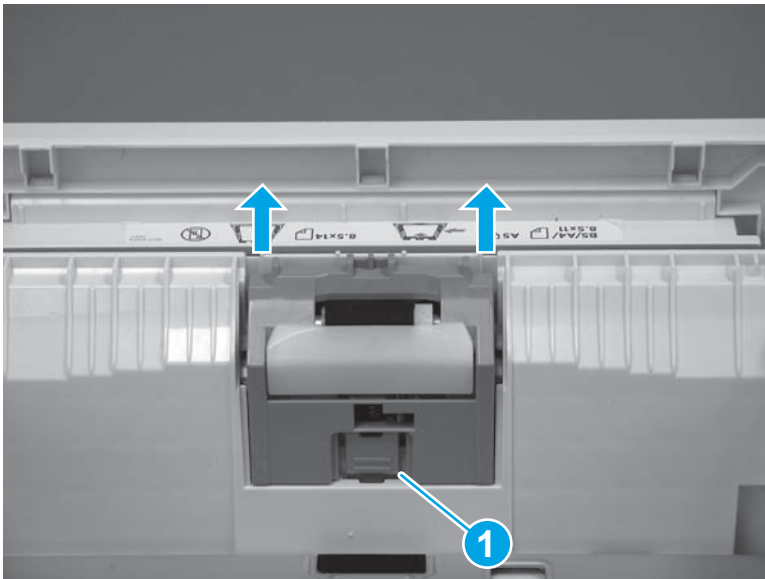

2. Remove the assembly.

Figure 1-2230 Remove the assembly

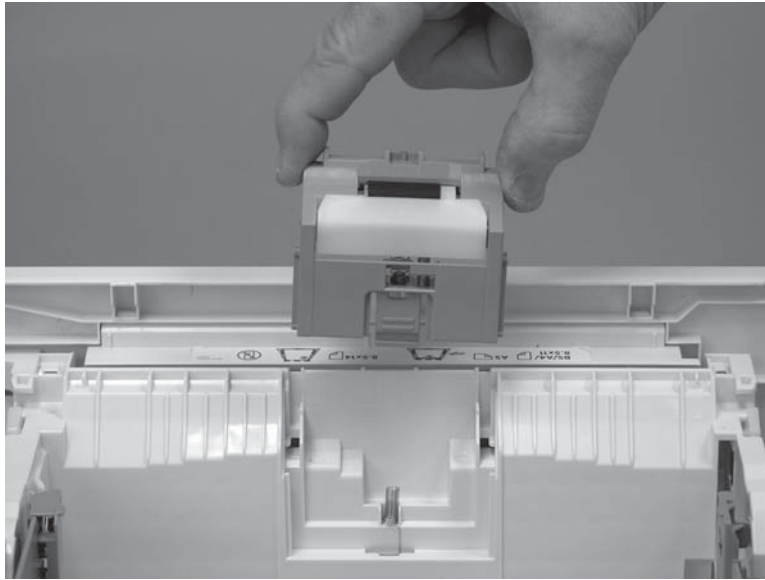

Step 3: Unpack the replacement assembly

Unpack the replacement part from the packaging.

<http://www8.hp.com/us/en/hp-information/environment/product-recycling.html>

 **NOTE:** HP recommends responsible disposal of the defective part.

Figure 1-2231 Recycle and unpack

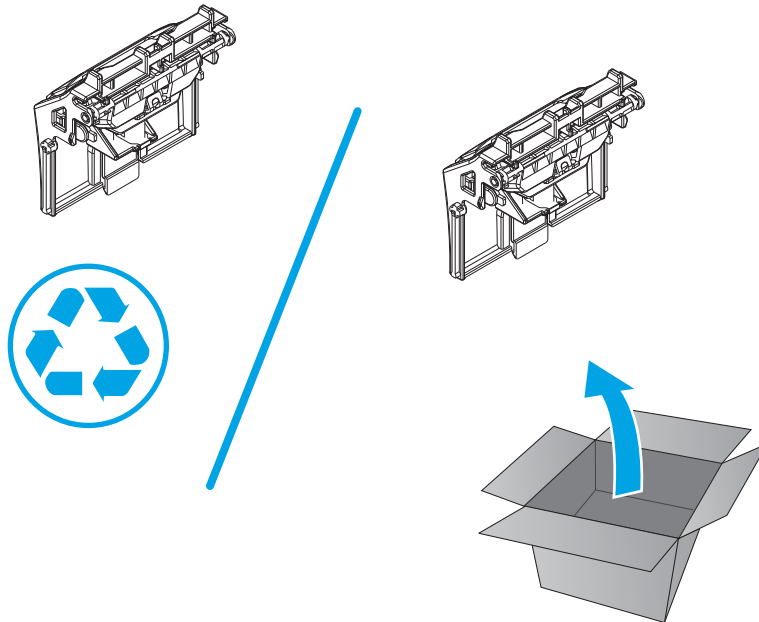

Step 4: Install the separation pad roller assembly (Tray 2)

1. Install the assembly in the slot in the cassette.

Figure 1-2232 Install the assembly

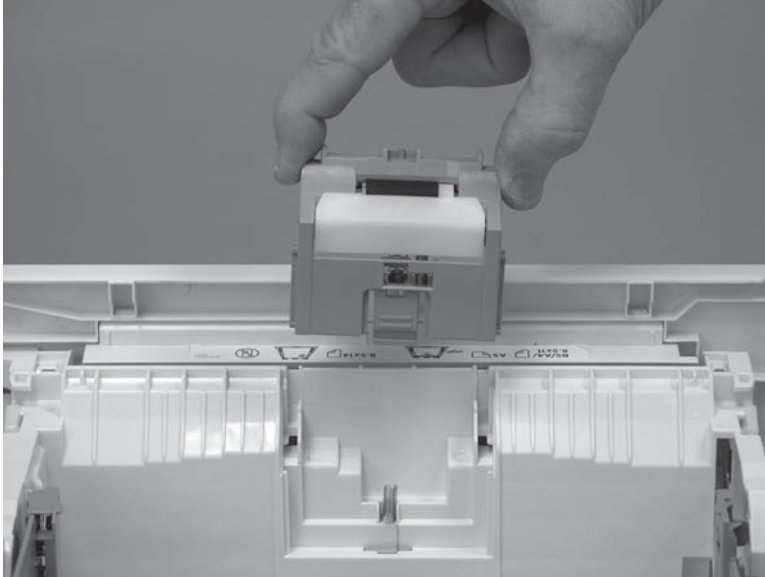

2. Push the separation pad assembly straight down until it snaps into place.

Figure 1-2233 Release the assembly

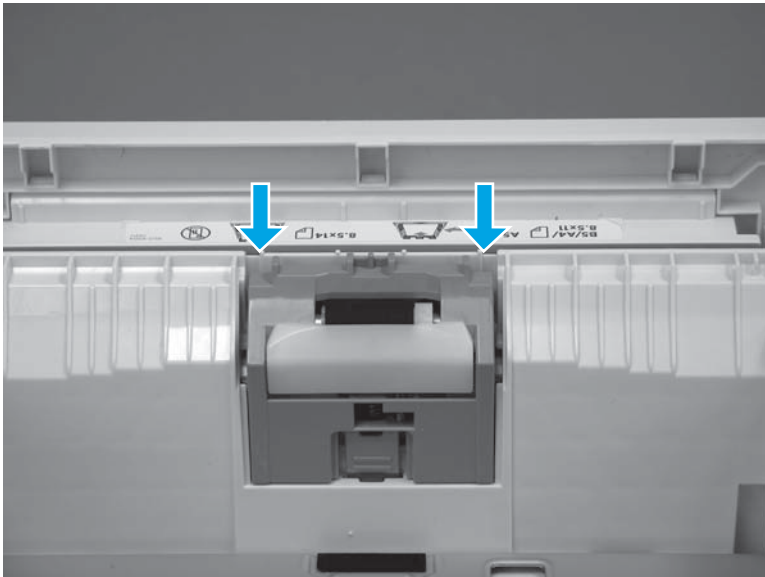

Step 5: Install Tray 2

- ▲ Slide the tray straight into the printer to install it.

Figure 1-2234 Install the tray



Removal and replacement: Accessories

- [550-sheet paper feeder](#)

550-sheet paper feeder



NOTE: HP recommends removing the accessory from the product before servicing them.

- [C5F97-69001 optional 550-sheet paper feeder](#)
- [RM2-5413-000CN optional Tray 3](#)
- [RM2-5741-000CN optional Tray 3 paper pickup roller assembly](#)
- [RM2-5745-000CN optional Tray 3 separation roller assembly](#)

C5F97-69001 optional 550-sheet paper feeder

- [Introduction](#)
- [Step 1: Remove the optional 550-sheet feeder Tray 3](#)
- [Step 2: Unpack the replacement optional paper feeder](#)
- [Step 3: Install the optional 550-sheet feeder Tray 3](#)

Introduction

This document provides the procedures to remove and replace the optional 550-sheet paper feeder.

Before performing service

Turn the printer power off

- Disconnect the power cable.

 **WARNING!** To avoid damage to the printer, turn the printer off, wait 30 seconds, and then remove the power cable before attempting to service the printer.

Use the table below to identify the correct part number for your printer. To order the part, go to www.hp.com/buy/parts.

Optional 550-sheet paper feeder part number	
C5F697-69001	Optional 550-sheet paper feeder (optional Tray 3)

Required tools

- No special tools are required to remove this part.

After performing service

Turn the printer power on

- Connect the power cable.
- Use the power switch to turn the power on.

Post service test

Make sure that the printer initializes to a **Ready** state.

Print a page from the optional Tray 3 to make sure that the paper feeder is functioning correctly.

Step 1: Remove the optional 550-sheet feeder Tray 3

- ▲ Carefully lift the printer off of the paper feeder assembly.

Figure 1-2235 Remove the printer

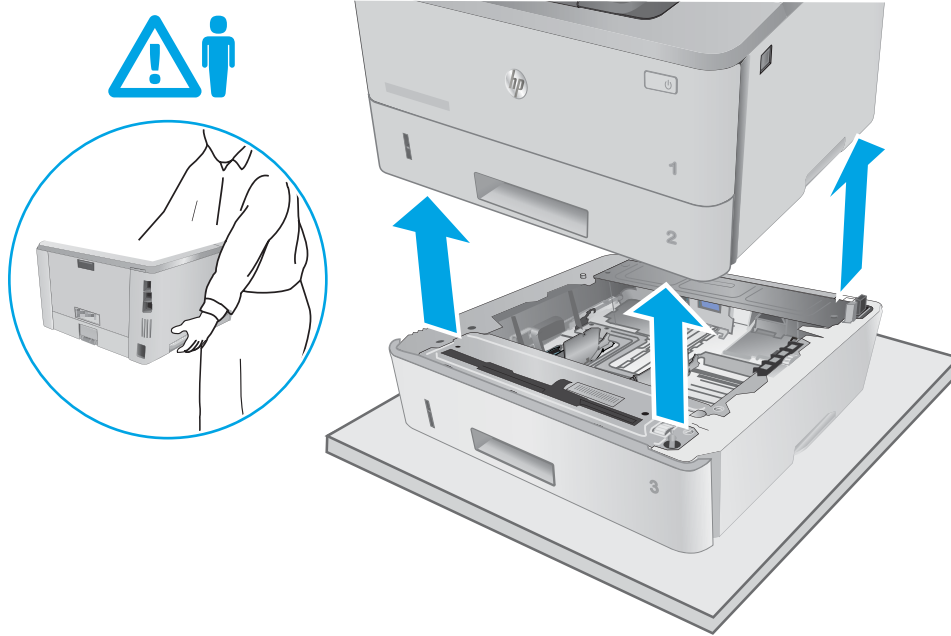

Step 2: Unpack the replacement optional paper feeder

Unpack the replacement part from the packaging.

<http://www8.hp.com/us/en/hp-information/environment/product-recycling.html>

 **NOTE:** HP recommends responsible disposal of the defective part.

Figure 1-2236 Recycle and unpack



Step 3: Install the optional 550-sheet feeder Tray 3

1. Remove the orange shipping tape.

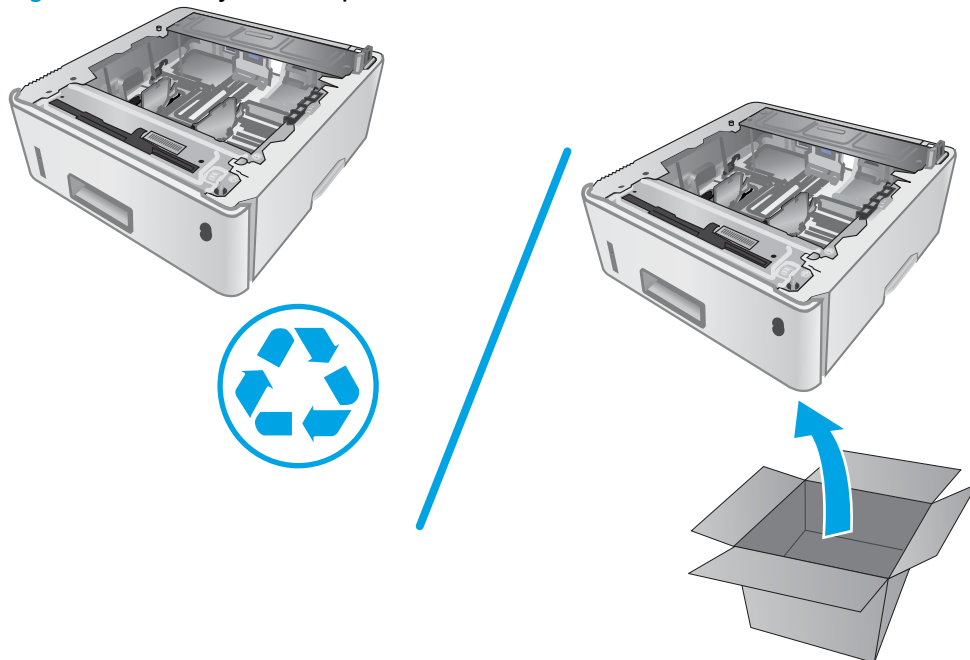
Figure 1-2237 Remove shipping tape

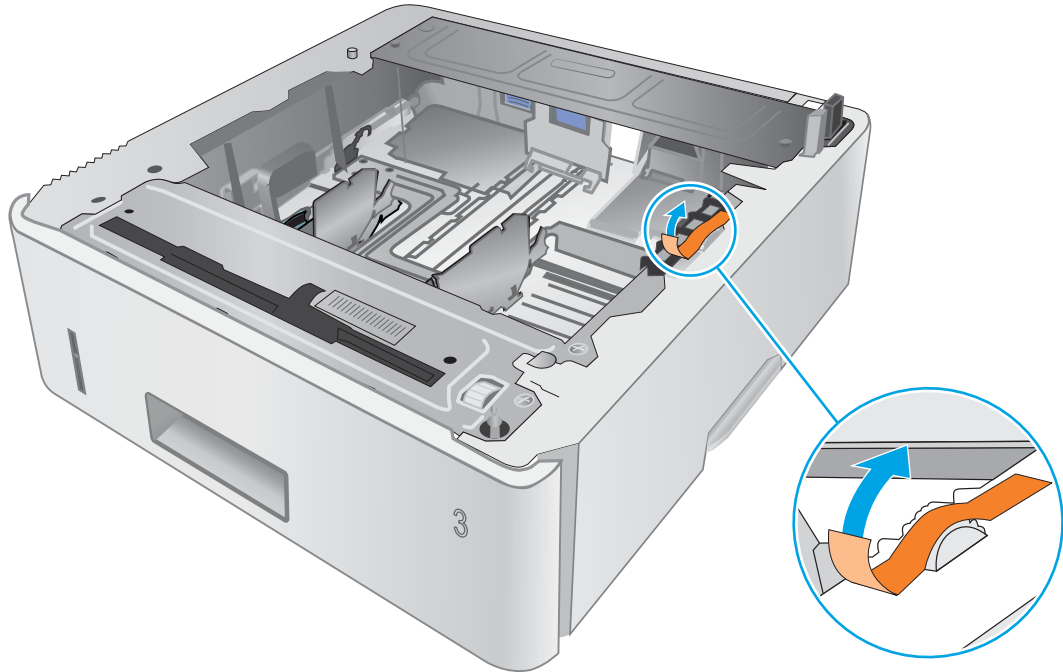

2. Carefully place the printer on the paper feeder assembly.

Figure 1-2238 Install the printer

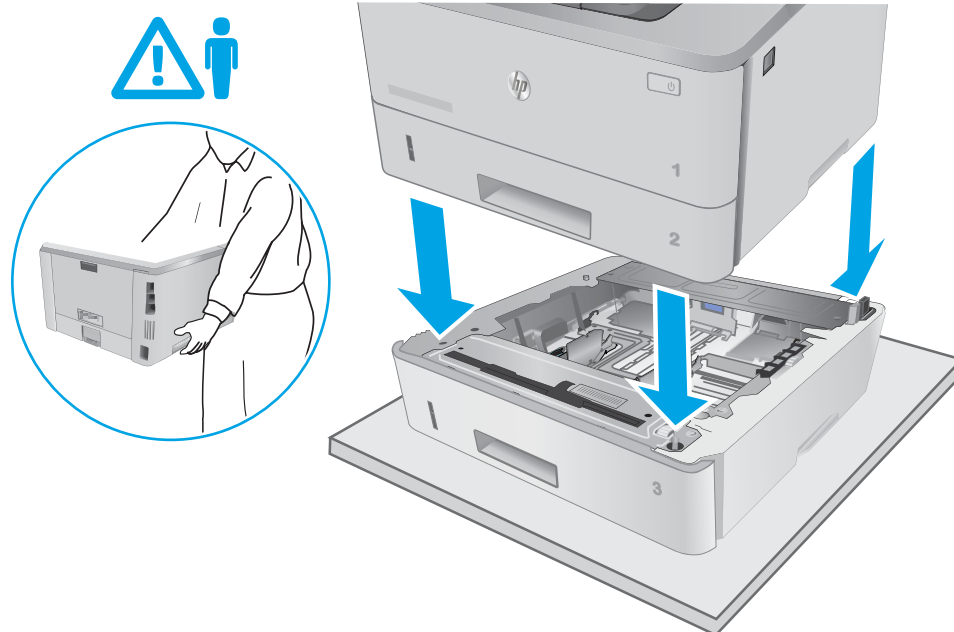

3. Pull Tray 3 out of the paper feeder assembly to remove it.

Figure 1-2239 Remove Tray 3

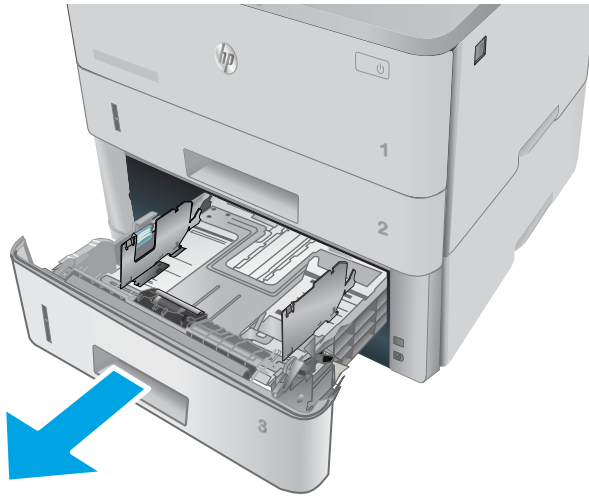

4. Adjust the Tray 3 sliding paper guides.

Figure 1-2240 Adjust the paper guides

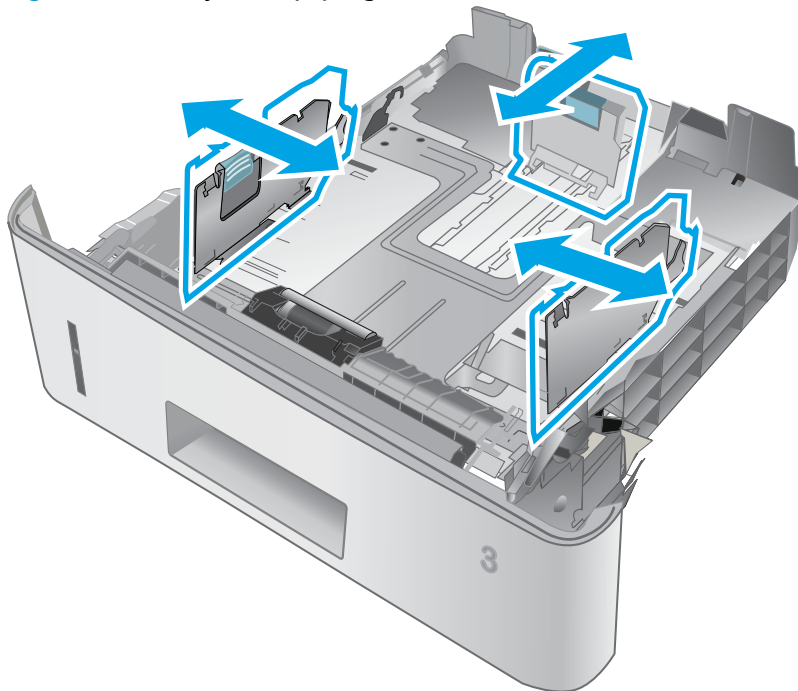

5. Load paper in Tray 3.

Figure 1-2241 Load paper

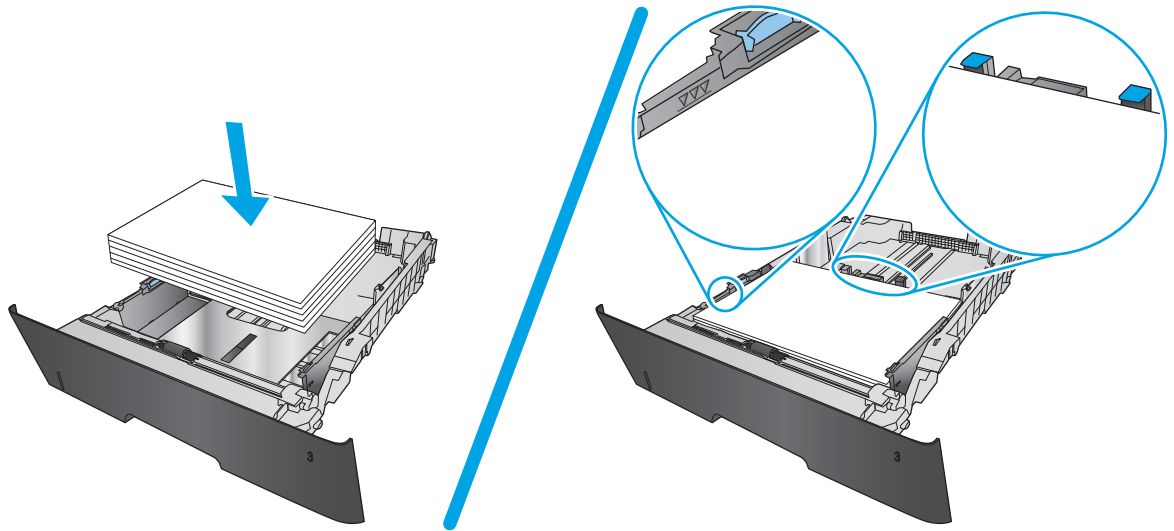

6. Slide Tray 3 into the paper feeder assembly to install it.

Figure 1-2242 Install



RM2-5413-000CN optional Tray 3

- [Introduction](#)
- [Step 1: Remove optional Tray 3](#)
- [Step 2: Unpack the replacement assembly](#)
- [Step 3: Install optional Tray 3](#)

Introduction

This document provides the procedures to remove and replace the optional Tray 3.

Before performing service

Turn the printer power off

- Disconnect the power cable.

 **WARNING!** To avoid damage to the printer, turn the printer off, wait 30 seconds, and then remove the power cable before attempting to service the printer.

Use the table below to identify the correct part number for your printer. To order the part, go to www.hp.com/buy/parts.

Tray 3 part number	
RM2-5413-000CN	550-sheet paper feeder cassette (optional Tray 3)

Required tools

- No special tools are required to remove this part.

After performing service

Turn the printer power on

- Connect the power cable.
- Use the power switch to turn the power on.

Post service test

Make sure that the printer initializes to a **Ready** state.

Print a page from Tray 3 to make sure that the paper feeder is functioning correctly.

Step 1: Remove optional Tray 3

1. Pull the tray straight out of the printer until it stops.

Figure 1-2243 Pull the tray out of the printer

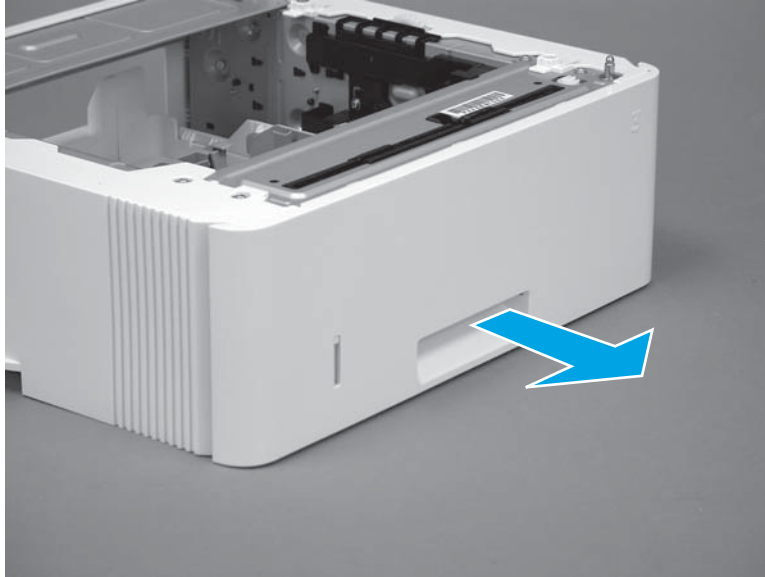

2. Slightly lift up on the front of the tray to release it, and then continue to pull the tray out of the accessory to remove it.

Figure 1-2244 Release and remove the tray

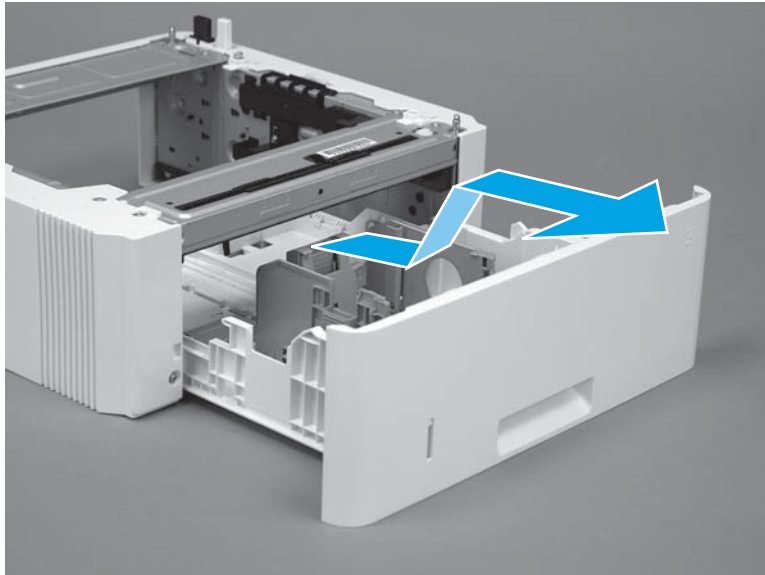

Step 2: Unpack the replacement assembly

Unpack the replacement part from the packaging.

<http://www8.hp.com/us/en/hp-information/environment/product-recycling.html>



NOTE: HP recommends responsible disposal of the defective part.

Figure 1-2245 Recycle and unpack

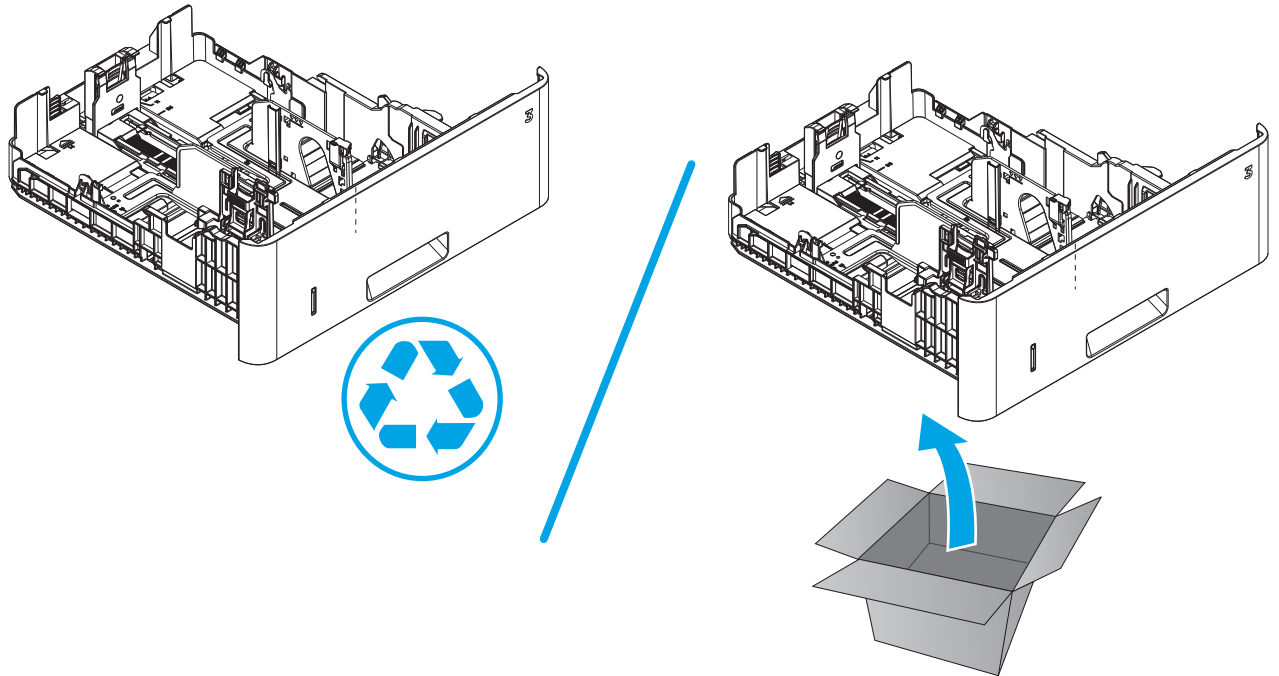

Step 3: Install optional Tray 3

1. With the tray at a slight angle, align the sides of the tray with the rails in the accessory, and then partially slide the tray into the accessory.

Figure 1-2246 Install the tray

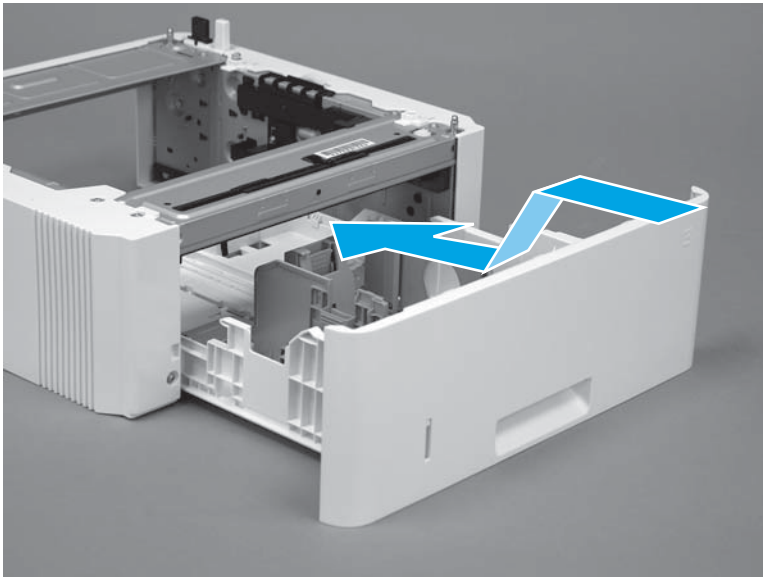

2. Push the tray straight into the accessory to close it.

Figure 1-2247 Close the tray

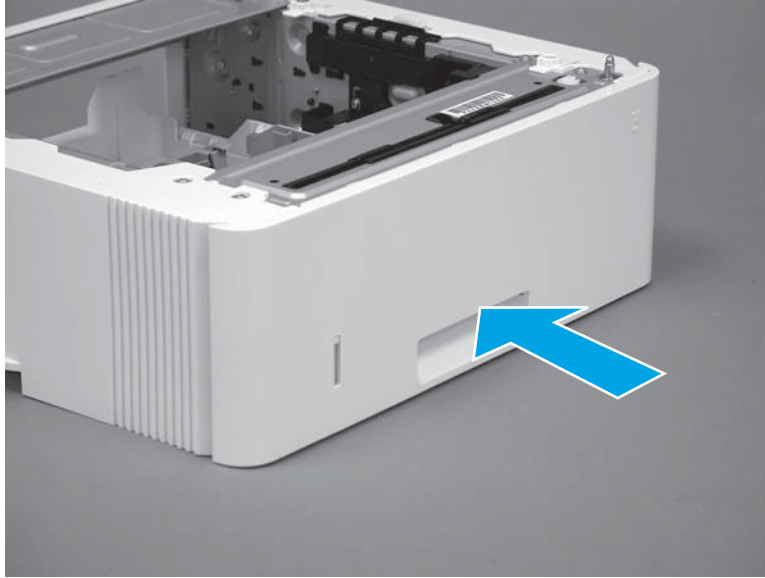

RM2-5741-000CN optional Tray 3 paper pickup roller assembly

- [Introduction](#)
- [Step 1: Remove optional Tray 3](#)
- [Step 2: Remove the paper pickup roller assembly \(Tray 3\)](#)
- [Step 3: Unpack the replacement assembly](#)
- [Step 4: Install the paper pickup roller assembly \(Tray 3\)](#)
- [Step 5: Install optional Tray 3](#)

Introduction

This document provides the procedures to remove and replace the paper pickup roller assembly (Tray 3).

Before performing service

Turn the printer power off

- Disconnect the power cable.

 **WARNING!** To avoid damage to the printer, turn the printer off, wait 30 seconds, and then remove the power cable before attempting to service the printer.

Use the table below to identify the correct part number for your printer. To order the part, go to www.hp.com/buy/parts.

Paper pickup roller assembly (Tray 3) part number	
---	--

RM2-5741-000N	Paper pickup roller assembly (Tray 3)
---------------	---------------------------------------

Required tools

- No special tools are required to remove this part.

After performing service

Turn the printer power on

- Connect the power cable.
- Use the power switch to turn the power on.

Post service test

Make sure that the printer initializes to a **Ready** state.

Print a page from the accessory to make sure that the printer is functioning correctly.

Step 1: Remove optional Tray 3

1. Pull the tray straight out of the printer until it stops.

Figure 1-2248 Pull the tray out of the printer

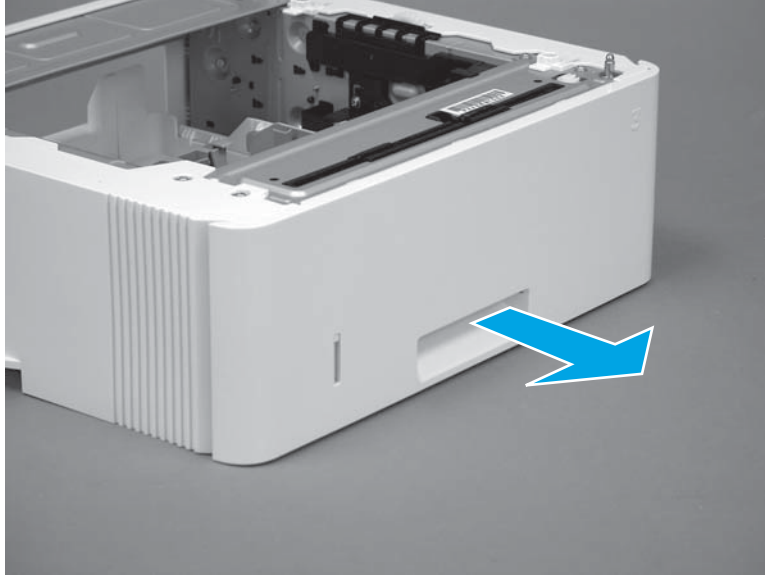

2. Slightly lift up on the front of the tray to release it, and then continue to pull the tray out of the accessory to remove it.

Figure 1-2249 Release and remove the tray

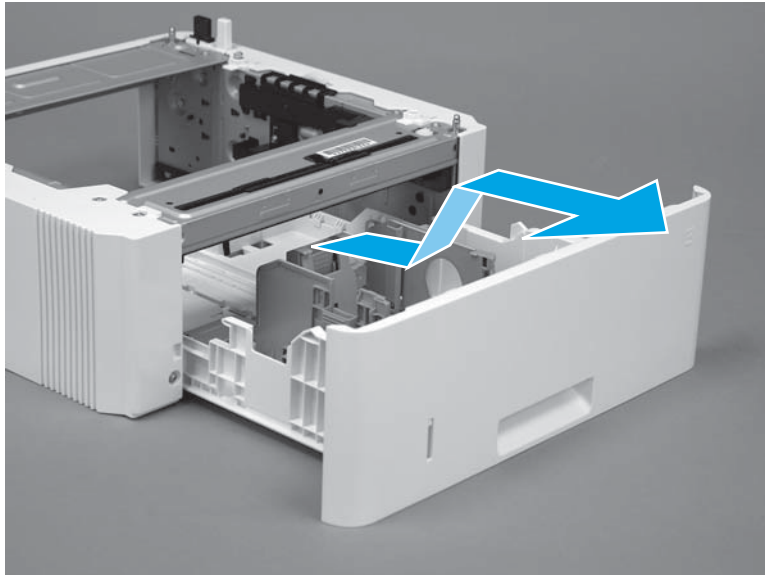

Step 2: Remove the paper pickup roller assembly (Tray 3)

CAUTION: When handling the roller holder, do not touch the gray spongy portion of the rollers. Skin oils on the rollers can cause paper handling problems.

1. Carefully turn the accessory over to expose the roller assembly.

Figure 1-2250 Turn the accessory over

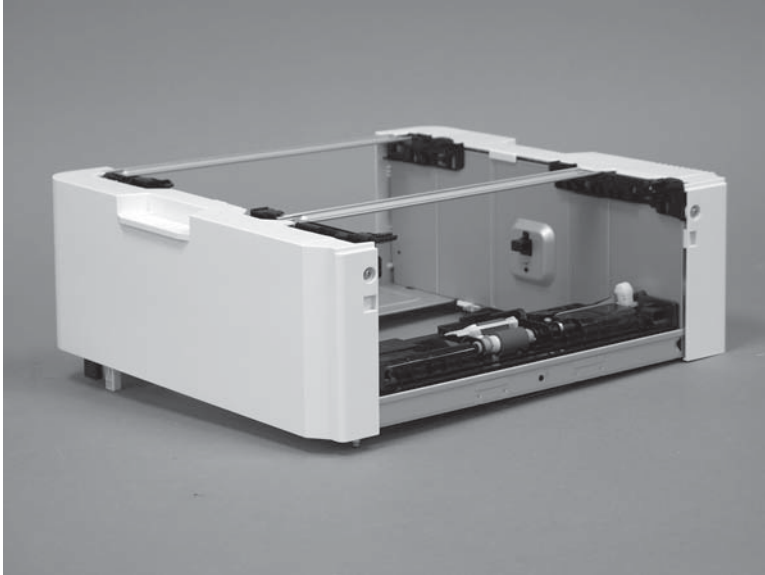

2. Slide the roller holder to the right to compress the spring-loaded shaft and release the assembly.

Figure 1-2251 Release the assembly

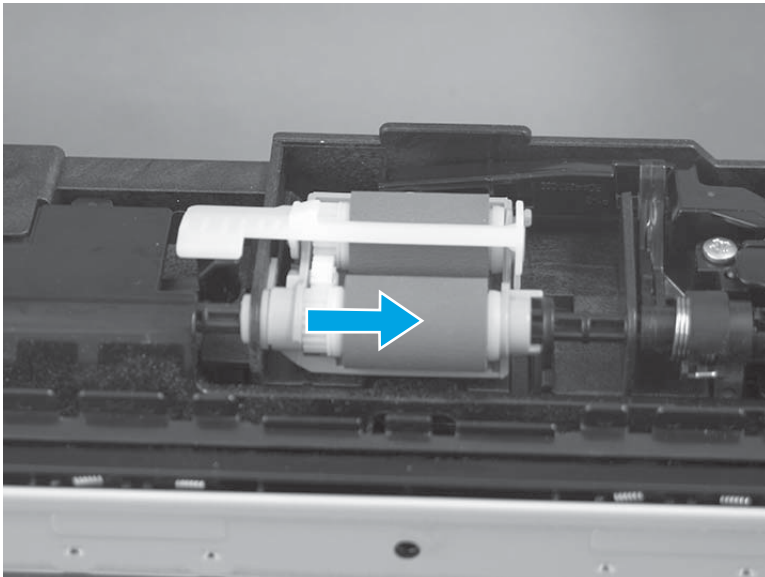

3. Rotate the end of the assembly up and away from the accessory.

Figure 1-2252 Rotate the assembly up

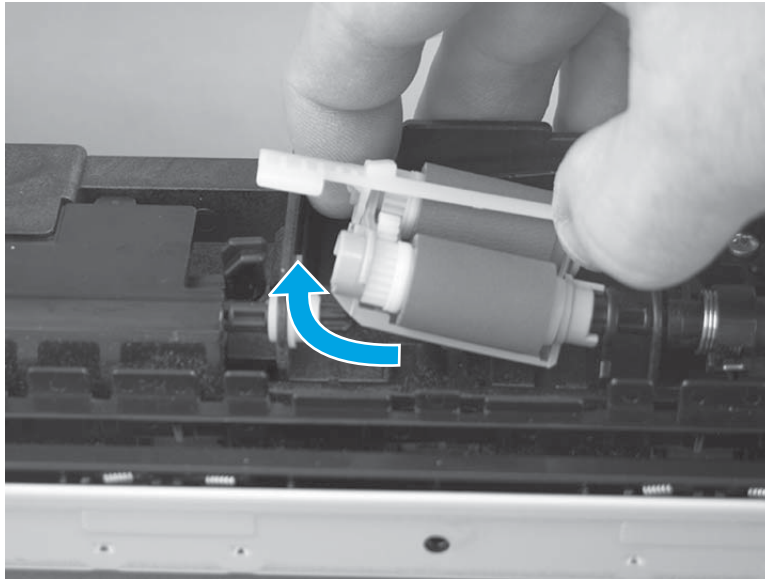

4. Remove the roller assembly.

Figure 1-2253 Remove the assembly

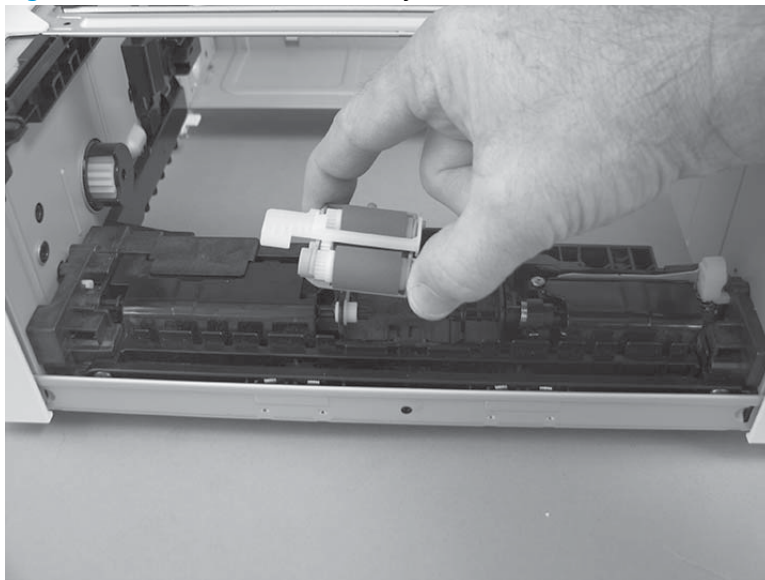

Step 3: Unpack the replacement assembly

Unpack the replacement part from the packaging.

<http://www8.hp.com/us/en/hp-information/environment/product-recycling.html>

CAUTION: When handling the roller holder, do not touch the gray spongy portion of the rollers. Skin oils on the rollers can cause paper handling problems.

NOTE: HP recommends responsible disposal of the defective part.

Figure 1-2254 Recycle and unpack

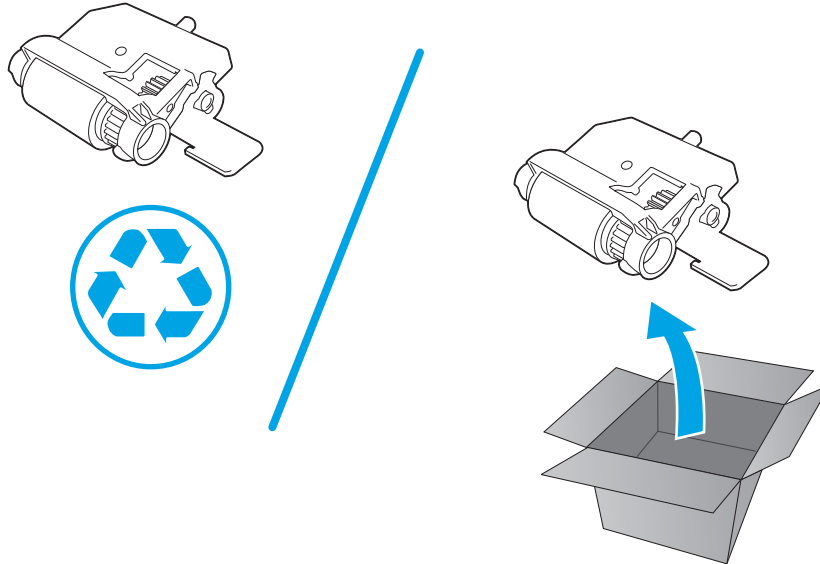

Step 4: Install the paper pickup roller assembly (Tray 3)

CAUTION: When handling the roller holder, do not touch the gray spongy portion of the rollers. Skin oils on the rollers can cause paper handling problems.

1. Install the right end of the assembly on the spring-loaded shaft (callout 1), and then slide it to the right to compress the shaft (callout 2).

IMPORTANT: Make sure that the pin on the back of the holder (callout 3) is inserted in the slot (callout 4) in the lever arm. If the pin is not correctly installed, the accessory will not pick paper.

Figure 1-2255 Install the roller assembly

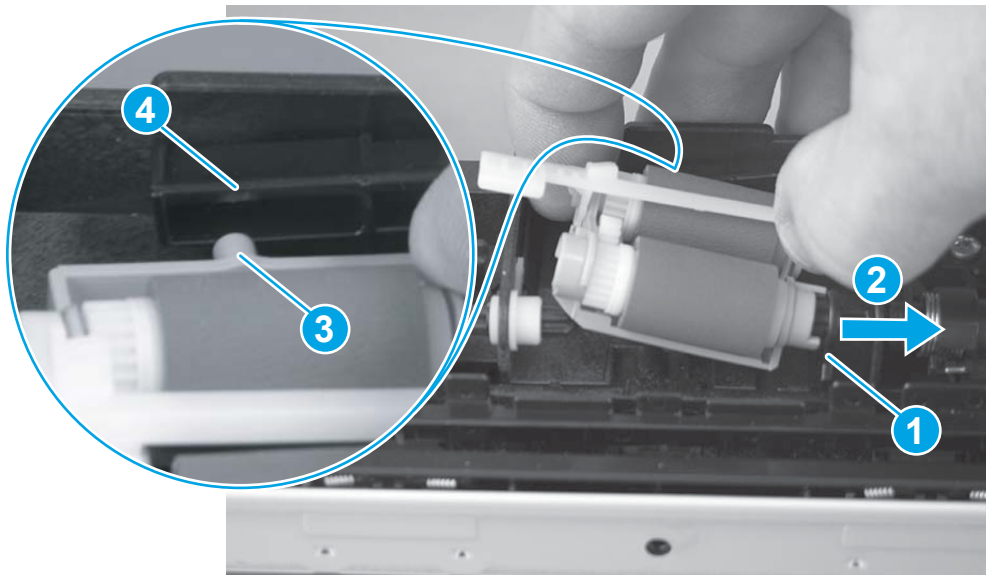

2. Rotate the left end of the assembly down and into place (callout 1), and then slide the assembly to the left (callout 2) to engage the drive end of the assembly with the drive shaft (callout 3).

Figure 1-2256 Release the assembly

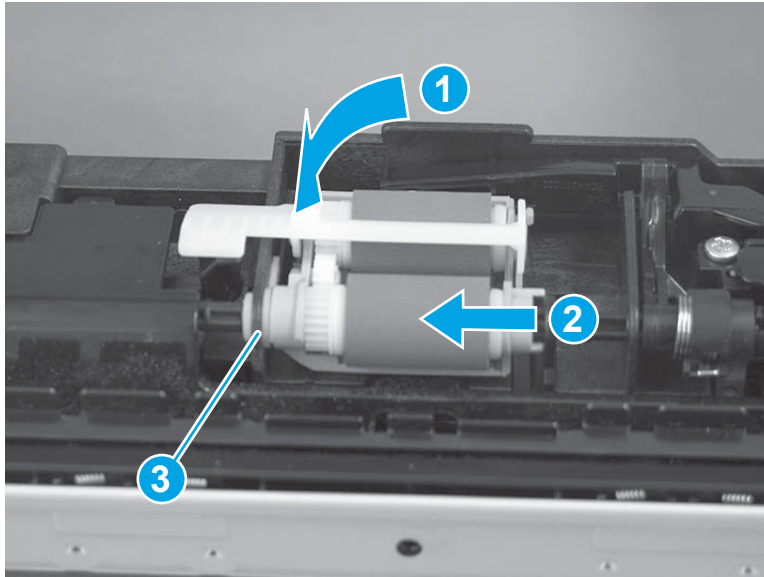

3. Push down and then release the tray-roller actuator (callout 1) and observe the roller assembly. It should move up and down (callout 2) in response to the actuator.

 **NOTE:** If it does not, remove the roller assembly and reinstall it making sure that the pin on the back of the assembly is in the lever arm. See [Figure 1-35 Install the roller assembly on page 31](#).

Figure 1-2257 Check the installation



Step 5: Install optional Tray 3

1. With the tray at a slight angle, align the sides of the tray with the rails in the accessory, and then partially slide the tray into the accessory.

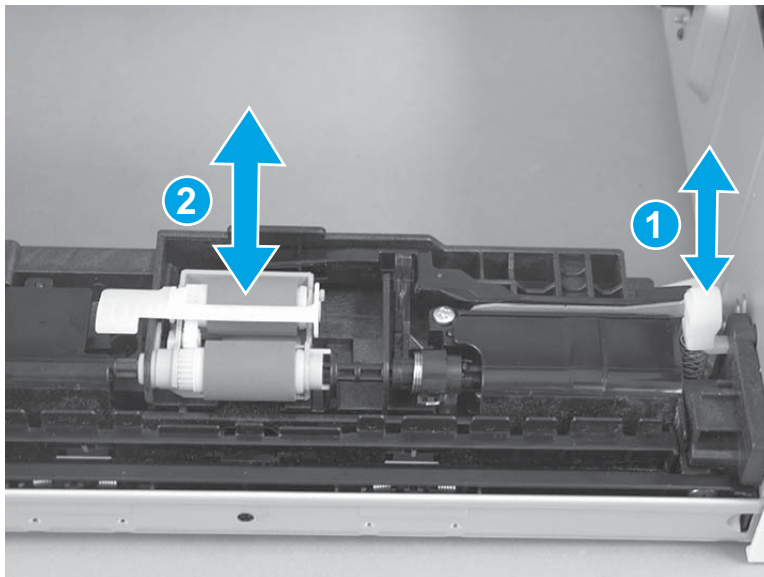
Figure 1-2258 Install the tray

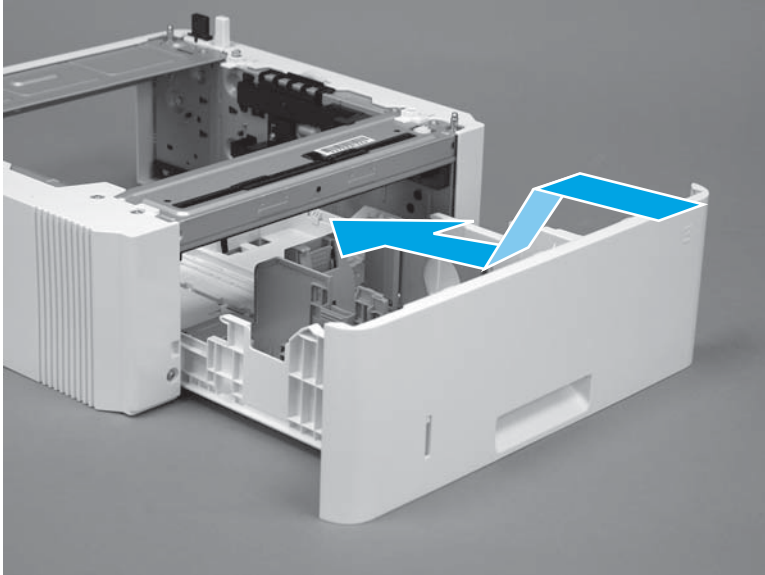

2. Push the tray straight into the accessory to close it.

Figure 1-2259 Close the tray

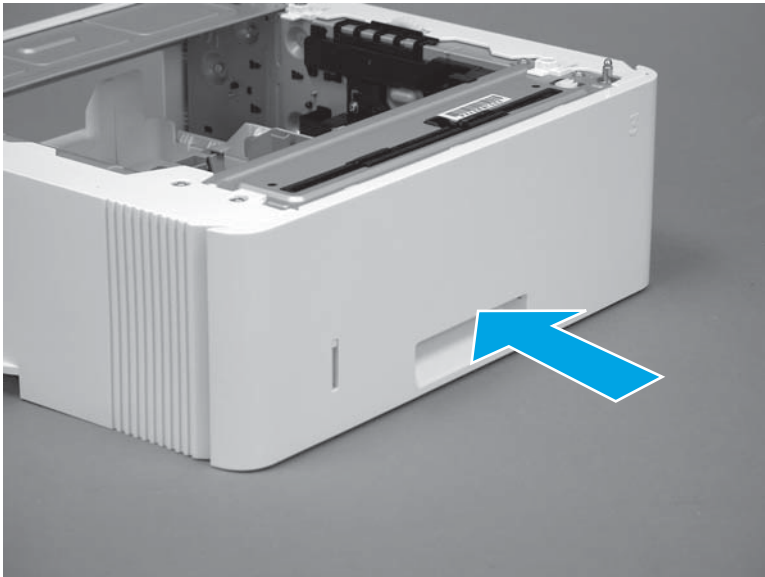

RM2-5745-000CN optional Tray 3 separation roller assembly

- [Introduction](#)
- [Step 1: Remove optional Tray 3](#)
- [Step 2: Remove the separation pad assembly \(550-sheet feeder\)](#)
- [Step 3: Unpack the replacement assembly](#)
- [Step 4: Install the separation pad assembly \(550-sheet feeder\)](#)
- [Step 5: Install optional Tray 3](#)

Introduction

This document provides the procedures to remove and replace the separation roller assembly (500-sheet feeder).

Before performing service

Turn the printer power off

- Disconnect the power cable.

 **WARNING!** To avoid damage to the printer, turn the printer off, wait 30 seconds, and then remove the power cable before attempting to service the printer.

Use the table below to identify the correct part number for your printer. To order the part, go to www.hp.com/buy/parts.

Separation roller assembly (550-sheet feeder) part number	
RM2-5745-000CN	Separation roller assembly (550-sheet feeder)

Required tools

- No special tools are required to install this kit.

After performing service

Turn the printer power on

- Connect the power cable.
- Use the power switch to turn the power on.

Post service test

Make sure that the printer initializes to a **Ready** state.

Print a page from the accessory to make sure that the accessory is functioning correctly.

Step 1: Remove optional Tray 3

1. Pull the tray straight out of the printer until it stops.

Figure 1-2260 Pull the tray out of the printer

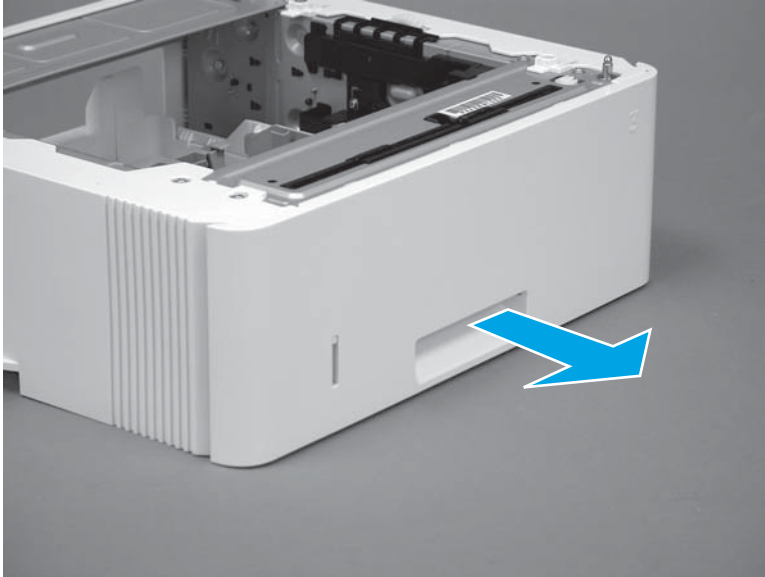

2. Slightly lift up on the front of the tray to release it, and then continue to pull the tray out of the accessory to remove it.

Figure 1-2261 Release and remove the tray

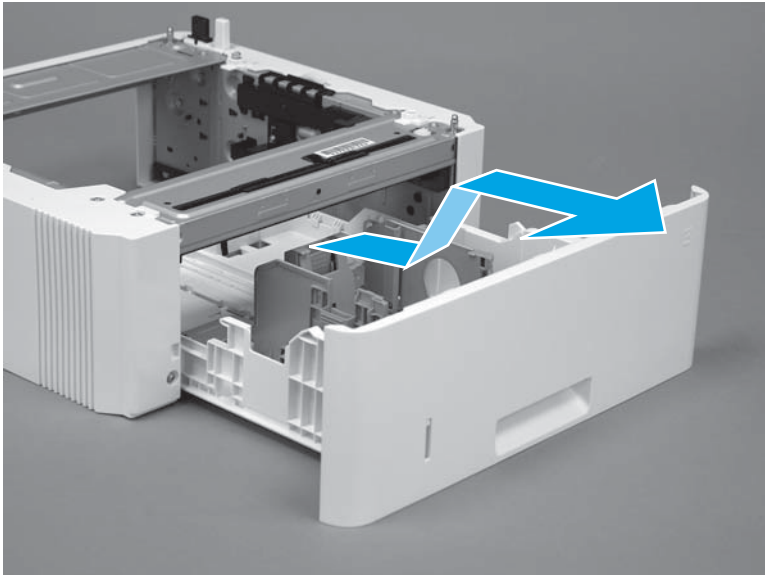

Step 2: Remove the separation pad assembly (550-sheet feeder)

1. Press the locking lever (callout 1), and then pull the separation roller assembly straight up to release it.

Figure 1-2262 Release the assembly

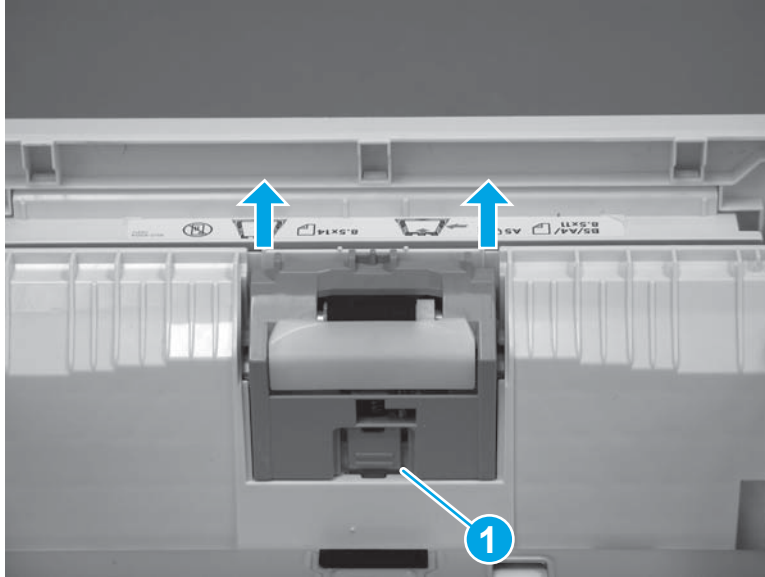

2. Remove the assembly.

Figure 1-2263 Remove the assembly

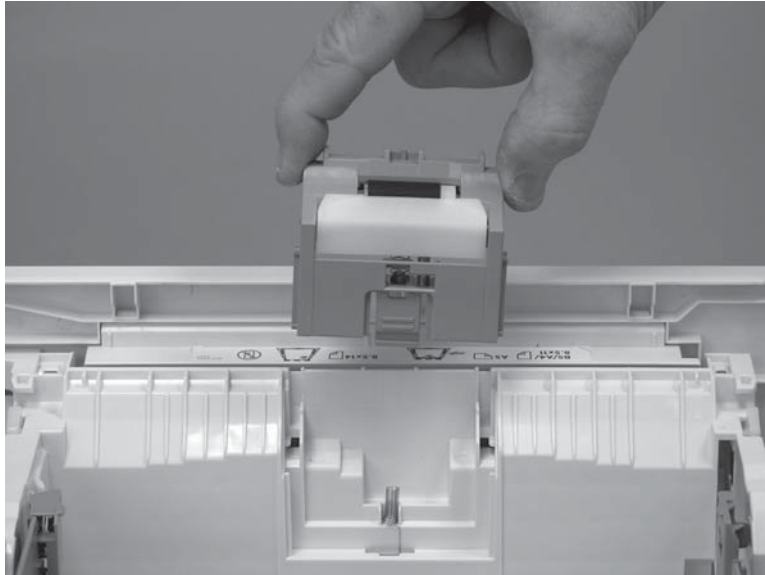

Step 3: Unpack the replacement assembly

Unpack the replacement part from the packaging.

<http://www8.hp.com/us/en/hp-information/environment/product-recycling.html>



NOTE: HP recommends responsible disposal of the defective part.

Figure 1-2264 Recycle and unpack

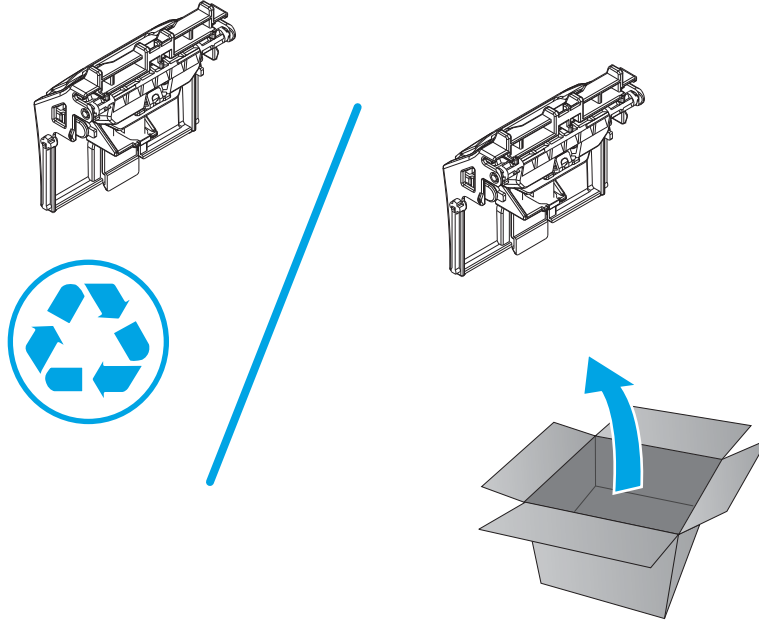

Step 4: Install the separation pad assembly (550-sheet feeder)

1. Install the assembly in the slots in the cassette.

Figure 1-2265 Install the assembly

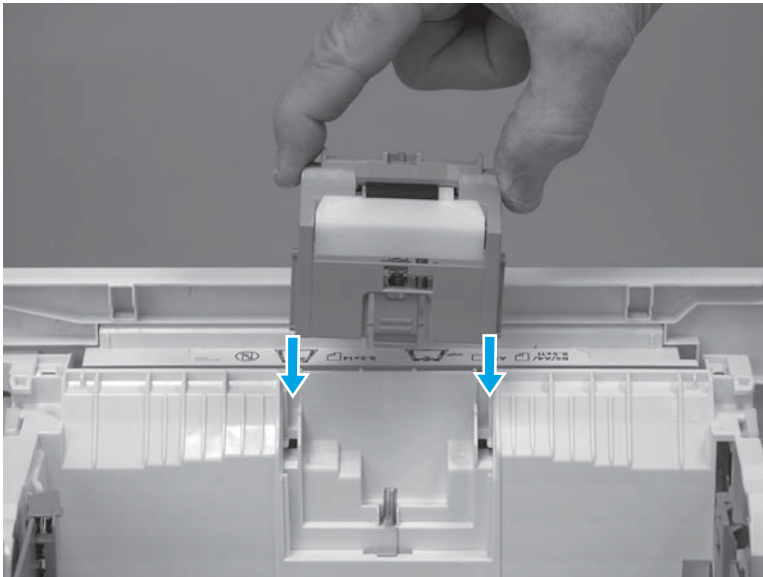

2. Push the separation roller assembly straight down until it snaps into place.

Figure 1-2266 Release the assembly

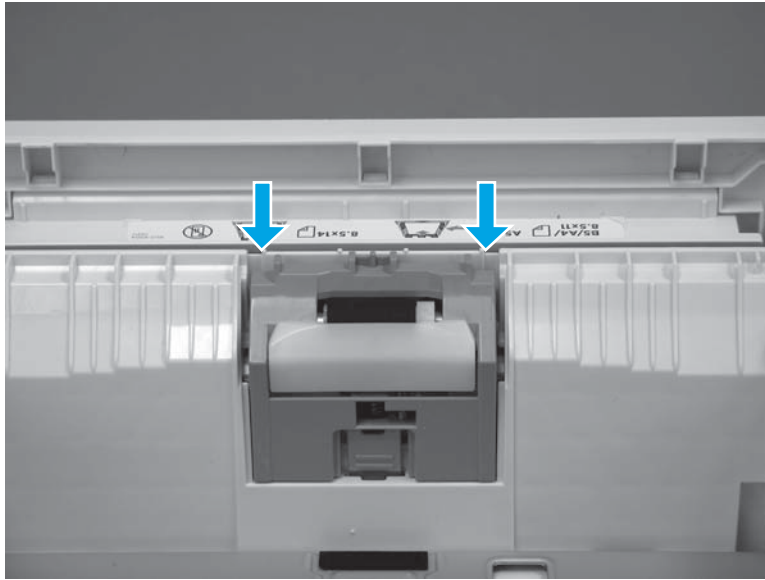

Step 5: Install optional Tray 3

1. With the tray at a slight angle, align the sides of the tray with the rails in the accessory, and then partially slide the tray into the accessory.

Figure 1-2267 Install the tray

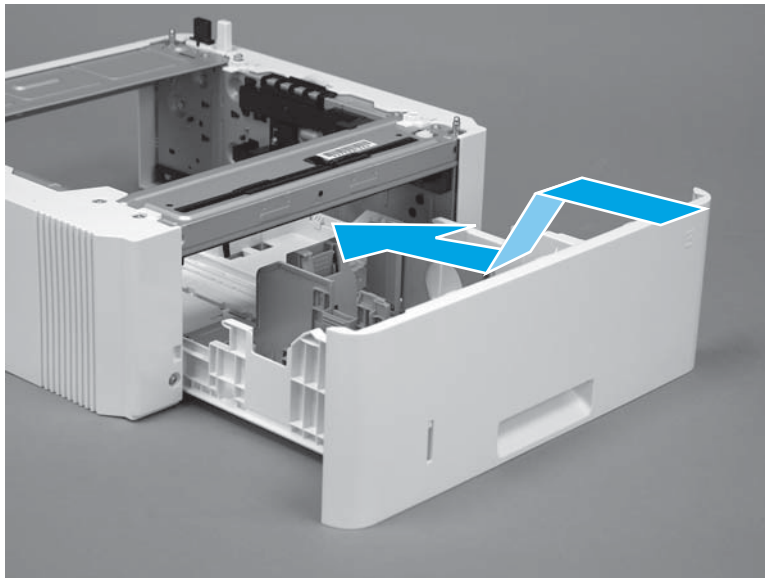

2. Push the tray straight into the accessory to close it.

Figure 1-2268 Close the tray

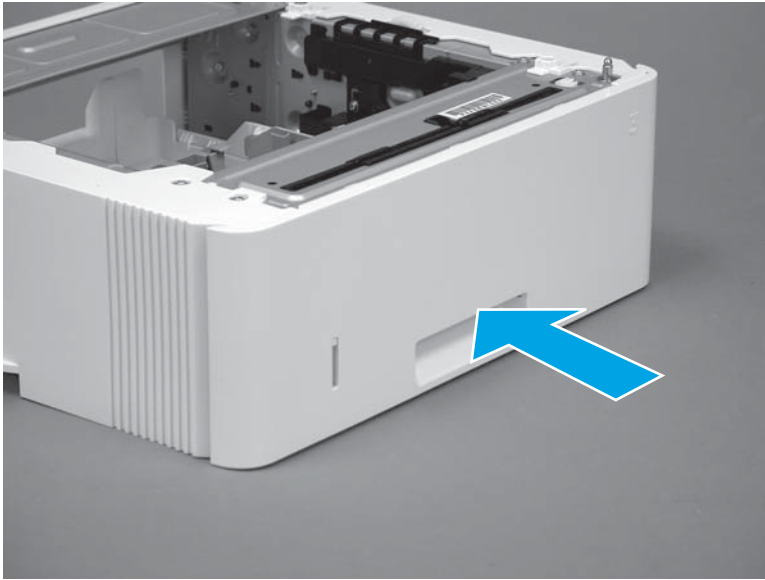

2 Parts and diagrams

- [For additional service and support](#)
- [Order parts, accessories, and supplies](#)
- [How to use the parts lists and diagrams](#)
- [Document feeder and image scanner](#)
- [Covers, printer base](#)
- [Internal components, printer base](#)
- [550-sheet paper feeder](#)
- [Alphabetical parts list](#)
- [Numerical parts list](#)

For additional service and support

HP service personnel, go to the Service Access Work Bench (SAW) at <http://h41302.www4.hp.com/km/saw/home.do>.

Channel partners, go to HP Channel Services Network (CSN) at <https://h30125.www3.hp.com/hpcsn>.

- To access HP PartSurfer information from any mobile device, go to <http://partsurfermobile.hp.com/> or scan the Quick Response (QR) code below.



- Install and configure
- Printer specifications
- Up-to-date control panel message (CPMD) troubleshooting
- Solutions for printer issues and emerging issues
- Remove and replace part instructions and videos
- Service advisories
- Warranty and regulatory information

Order parts, accessories, and supplies

Ordering

Order supplies and paper	www.hp.com/go/suresupply
Order genuine HP parts or accessories	www.hp.com/buy/parts or partsurfer.hp.com
Order through service or support providers	Contact an HP-authorized service or support provider.
Order using the HP Embedded Web Server (EWS)	To access, in a supported Web browser on your computer, enter the printer IP address or host name in the address/URL field. The EWS contains a link to the HP SureSupply Web site, which provides options for purchasing Original HP supplies.

Orderable parts

Not all of the parts shown in the diagrams in this chapter can be ordered. Refer to the table following the diagram or the parts lists at the end of this chapter to determine if a part is orderable.

Supplies

Following are the part numbers for the supplies available for the printers.

Table 2-1 Supplies

Item	Description	Cartridge number	Part number
Supplies			
HP 26A Black Original LaserJet Toner Cartridge	Standard-capacity replacement black toner cartridge	26A	CF226A
NOTE: M402 and M426 models only			
HP 28A Black Original LaserJet Toner Cartridge	Standard-capacity replacement black toner cartridge	28A	CF228A
NOTE: M403 and M427 models only			
HP 26X High Yield Black Original LaserJet Toner Cartridge	High-capacity replacement black toner cartridge	26X	CF226X
NOTE: M402 and M426 models only			
HP 28X High Yield Black Original LaserJet Toner Cartridge)	High-capacity replacement black toner cartridge	28X	CF228X
NOTE: M403 and M427 models only			

Accessories

Following are the part numbers for the accessories available for the printer.

Table 2-2 Accessories

Item	Part number
550-sheet paper feeder (optional Tray 3)	C5F97-69001

Customer self-repair parts

Customer Self-Repair (CSR) parts are available for many HP LaserJet printers to reduce repair time. More information about the CSR program and benefits can be found at www.hp.com/go/csr-support and www.hp.com/go/csr-faq.

Genuine HP replacement parts can be ordered at www.hp.com/buy/parts or by contacting an HP-authorized service or support provider. When ordering, one of the following will be needed: part number, serial number (found on back of printer), printer number, or printer name.

- Parts listed as **Mandatory** self-replacement are to be installed by customers, unless you are willing to pay HP service personnel to perform the repair. For these parts, on-site or return-to-depot support is not provided under the HP printer warranty.
- Parts listed as **Optional** self-replacement can be installed by HP service personnel at your request for no additional charge during the printer warranty period.

Item	Description	Self-replacement options	Part number
250-sheet paper input tray	Replacement cassette for Tray 2	Mandatory	RM2-5392-000CN
Optional 550-sheet accessory tray	Replacement cassette for Tray 3	Mandatory	RM2-5413-000CN
Tray 2 separation roller assembly	Tray 2 separation roller	Mandatory	RM2-5397-000CN
Optional Tray 3 separation roller assembly	Optional Tray 3 separation roller	Mandatory	RM2-5745-000CN
Multipurpose roller	Multipurpose roller	Mandatory	RL2-0656-000CN
Tray 2 paper pickup roller assembly	Tray 2 pickup roller	Mandatory	RM2-5452-000CN
Optional Tray 3 paper pickup roller assembly	Optional Tray 3 pickup roller	Mandatory	RM2-5741-000CN

How to use the parts lists and diagrams

The figures in this chapter show the major subassemblies in the printer and their component parts. A parts list table follows each exploded view assembly diagram. Each table lists the item number, the associated part number, and the description of each part. If a part is not listed in the table, then it is not a field replacement unit (FRU).

 **CAUTION:** Be sure to order the correct part. When looking for part numbers for electrical components, pay careful attention to the voltage that is listed in the description column. Doing so will ensure that the part number selected is for the correct model.

 **NOTE:** In this manual, the abbreviation “PCA” stands for “printed circuit-board assembly.” Components described as a PCA might consist of a single circuit board or a circuit board plus other parts, such as cables and sensors.

Document feeder and image scanner

 **NOTE:** Parts listed in this section are for the M426 and M427 printers.

Main assemblies

Figure 2-1 Main assemblies (document feeder and image scanner)

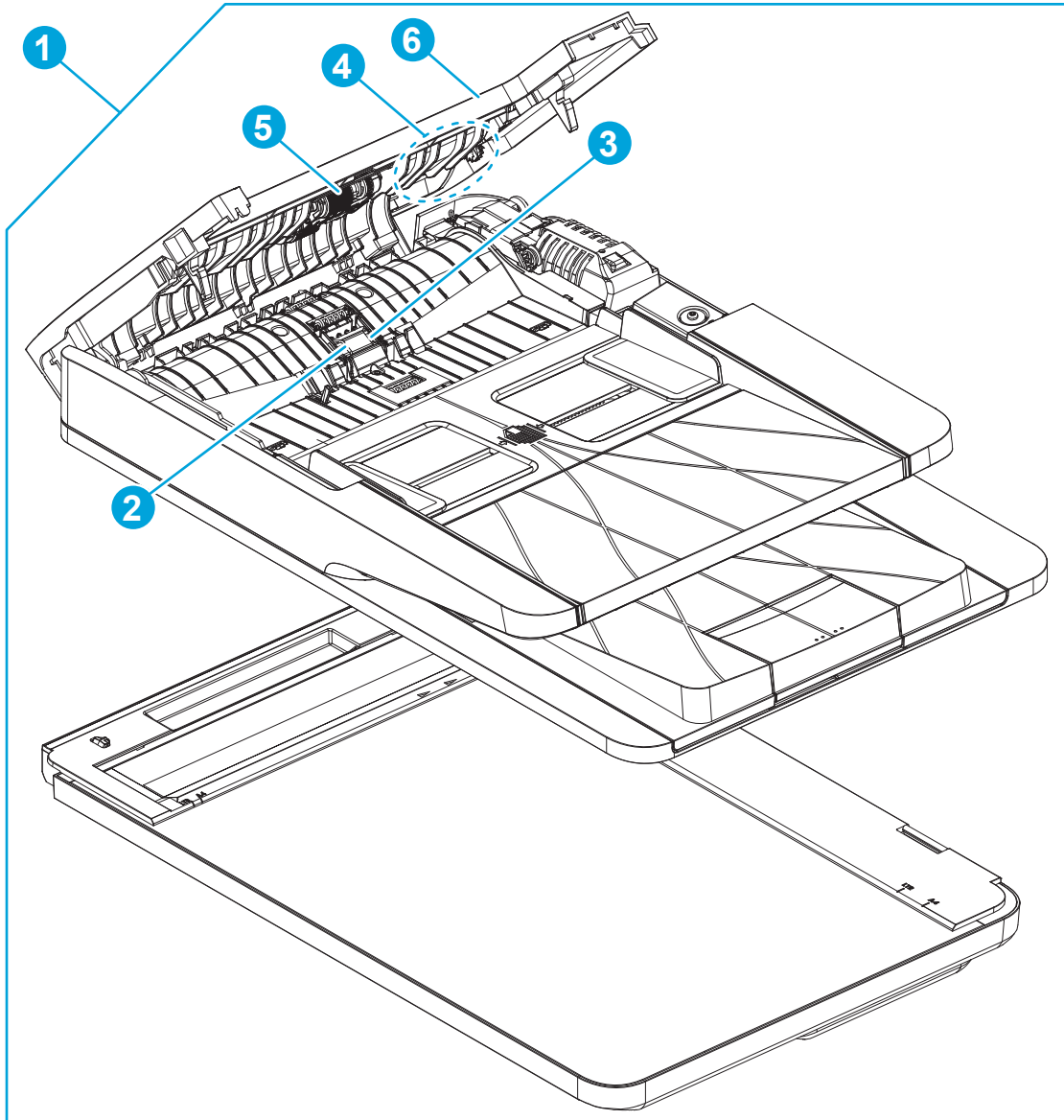

Table 2-3 Main assemblies (document feeder and image scanner)

Ref	Description	Part number	Qty
1	Document feeder and image scanner assembly (simplex models M426/M427)	C5F98-60109	1
1	Document feeder and image scanner assembly (duplex models M426/M427)	C5F98-60110	1
2	ADF separation pad	B3Q10-40080	1
3	Support, ADF separation pad	B3Q10-40079	1
Not shown	Spring, ADF separation pad (under the separation pad)	B3Q10-00019	1
4	Shaft, ADF pick extension	B3Q10-40081	1
5	ADF pick roller assembly	B3Q10-60105	1
6	Cover, ADF outer	B3Q10-40013	1
Not shown	Cover, ADF inner (under the out cover)	B3Q10-40012	1
Not shown	Ferrite ISA (M426fdn; M426fdw; M427fdn; M427fdw)	9170-2664	1
Not shown	Ferrite, ISA	9170-2437	1
Not shown	Ferrite, motor	9170-2659	1
Not shown	Cover, FFC	C5F98-40002	1
Not shown	Cover, core	C5F98-40003	1
Not shown	ISA lift	B3Q10-60128	1
Not shown	Slider pin, ISA lift	B3Q10-40041	1

Covers, printer base

Covers, M402 and M403

Figure 2-2 Covers, M402 and M403

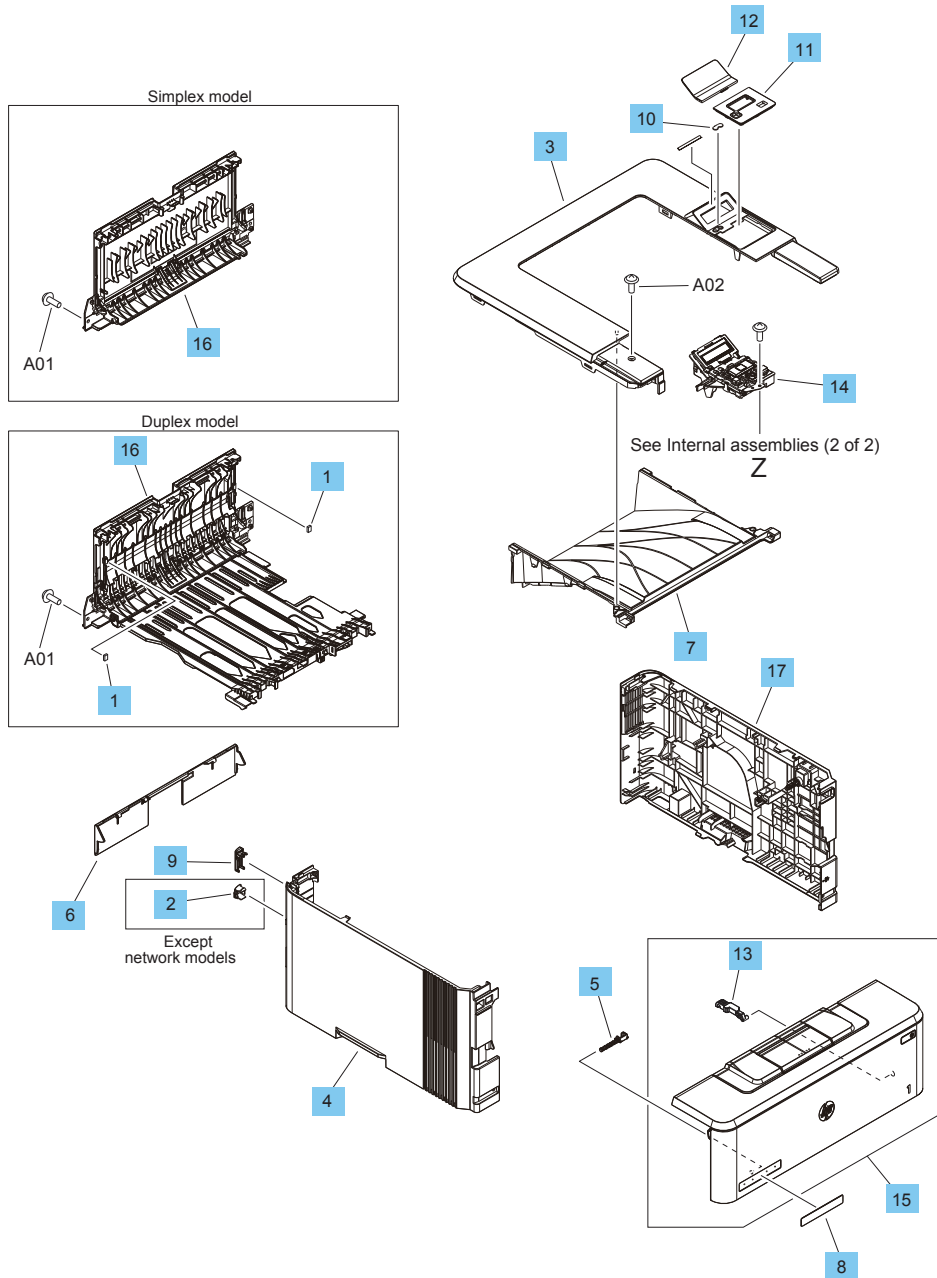

Table 2-4 Covers, M402 and M403

Ref	Description	Part number	Qty
1	Sheet, damper (duplex models only)	RC2-6075-000CN	2
2	Cover, network (non-network models M402/M403)	RC4-2907-000CN	1
3	Cover, top (M402/M403)	RC4-2956-000CN	1
4	Cover, left (M402/M403)	RL2-0673-000CN	1
5	Shaft, support	RC4-3002-000CN	1
6	Cover, cassette rear	RC4-3082-000CN	1
7	Tray, paper delivery	RC4-3231-000CN	1
8	Plate, name M402d	RC4-3288-000CN	1
8	Plate, name M402n	RC4-3270-000CN	1
8	Plate, name M403n	RC4-3267-000CN	1
8	Plate, name M403d	RC4-3266-000CN	1
8	Plate, name M402dn	RC4-3264-000CN	1
8	Plate, name M403dn	RC4-3268-000CN	1
8	Plate, name M402dw	RC4-3265-000CN	1
8	Plate, name M403dw	RC4-3269-000CN	1
9	Cover, rear USB (M402/M403)	RC4-3298-000CN	1
10	Guide, LED light	RC4-3311-000CN	1
11	Cover, operation (non-wireless models M402/M403)	RC4-3312-000CN	1
11	Cover, operation (wireless models M402/M403)	RC4-3322-000CN	1
12	Cover, indication	RL2-0675-000CN	1
13	Link, pressure release	RC4-4479-000CN	1
14	Control-panel assembly (non-wireless models M402/M403)	RM2-5391-000CN	1
14	Control-panel assembly (wireless models M402/M403)	RM2-5424-000CN	1
15	Cartridge door assembly (non-NFC models M402/M403)	RM2-5390-000CN	1
15	Cartridge door assembly (NFC models M402/M403)	RM2-5436-000CN	1
16	Door, rear assembly (simplex models M402/M403)	RM2-5430-000CN	1
16	Door, rear assembly (duplex models only)	RM2-5405-000CN	1
17	Cover, right assembly	RM2-5434-000CN	1
Not shown	HP logo jewel	7121-8686	1

Covers, M426 and M427

Figure 2-3 Covers, M426 and M427

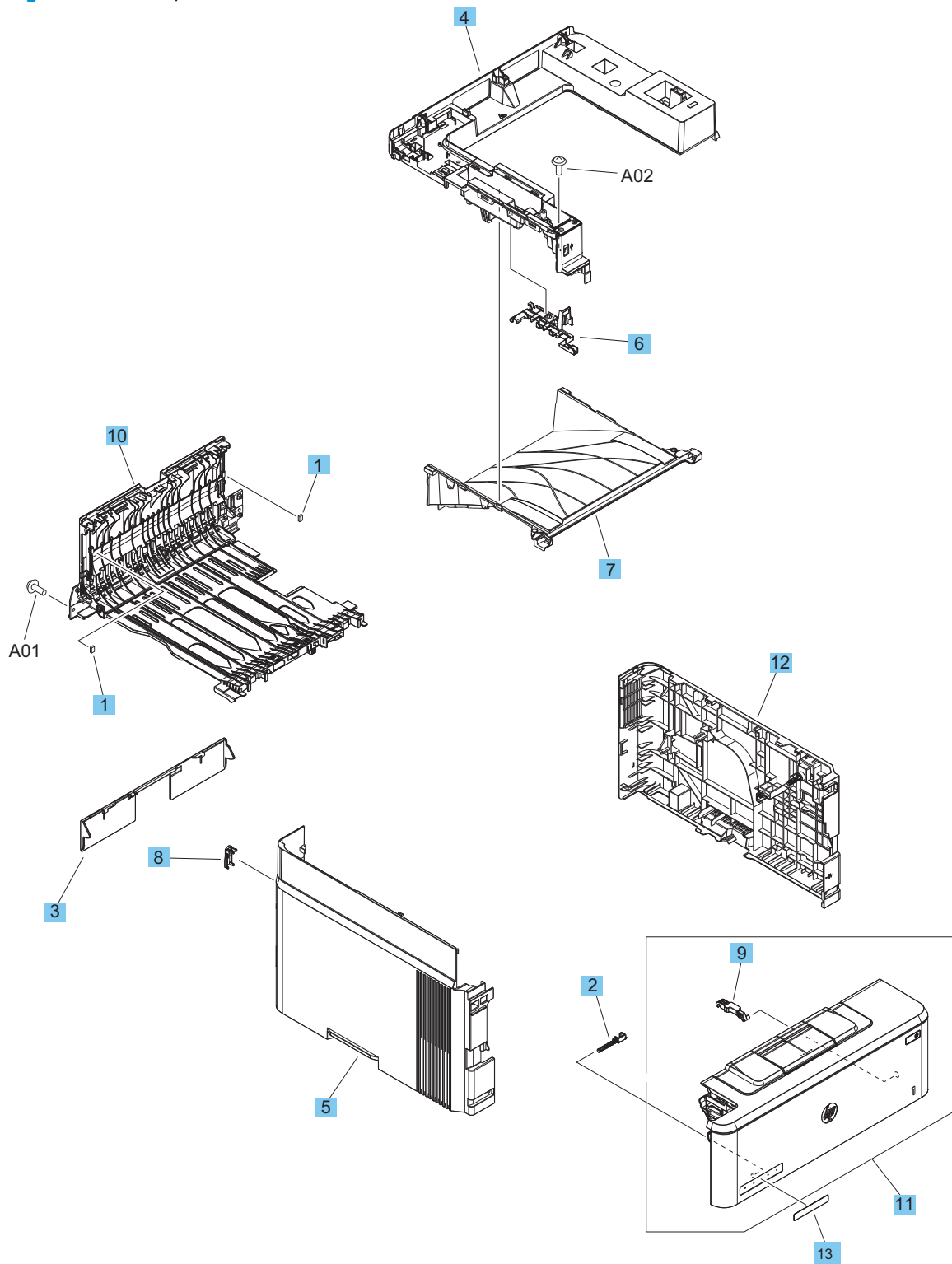

Table 2-5 Covers, M426 and M427

Ref	Description	Part number	Qty
1	Sheet, damper	RC2-6075-000CN	2
2	Shaft, support	RC4-3002-000CN	1
3	Cover, cassette rear	RC4-3082-000CN	1
4	Cover, top (M426/M427)	RC4-3207-000CN	1
5	Cover, left (M426/M427)	RL2-0674-000CN	1
6	Guide, cable	RC4-3217-000CN	1
7	Tray, paper delivery	RC4-3231-000CN	1
8	Cover, rear USB (M426 and M427)	RC4-3299-000CN	1
9	Link, pressure release	RC4-4479-000CN	1
10	Door, rear (duplex models only)	RM2-5405-000CN	1
11	Door, cartridge assembly (non-NFC models M426/M427)	RM2-5408-000CN	1
11	Door, cartridge assembly (NFC models M426/M427)	RM2-5435-000CN	1
12	Cover, right assembly	RM2-5434-000CN	1
13	Name plate M427dw	C5F97-40001	1
13	Name plate M427dn	C5F98-40004	1
13	Name plate M427fdw	C5F99-40002	1
13	Name plate M426dw	F6W13-40002	1
13	Name plate M426fdn	F6W14-40002	1
13	Name plate M426fdw	F6W15-40002	1
Not shown	Control panel (M426/M427)	B3Q10-60139	1
Not shown	Control panel mount cover	B3Q11-40002	1
Not shown	Control panel mount base	B3Q11-40001	1
Not shown	Control panel mount chassis assembly	B3Q10-60145	1
Not shown	Control panel 22-pin FFC	C5F98-60104	1
Not shown	Cover, fax port (M426fdn; M426fdw; 427fdn; M427fdw)	C5F99-40003	1
Not shown	HP logo jewel	7121-8686	1

Internal components, printer base

Internal components, printer base (1 of 3)

Figure 2-4 Internal components, printer base (1 of 5)

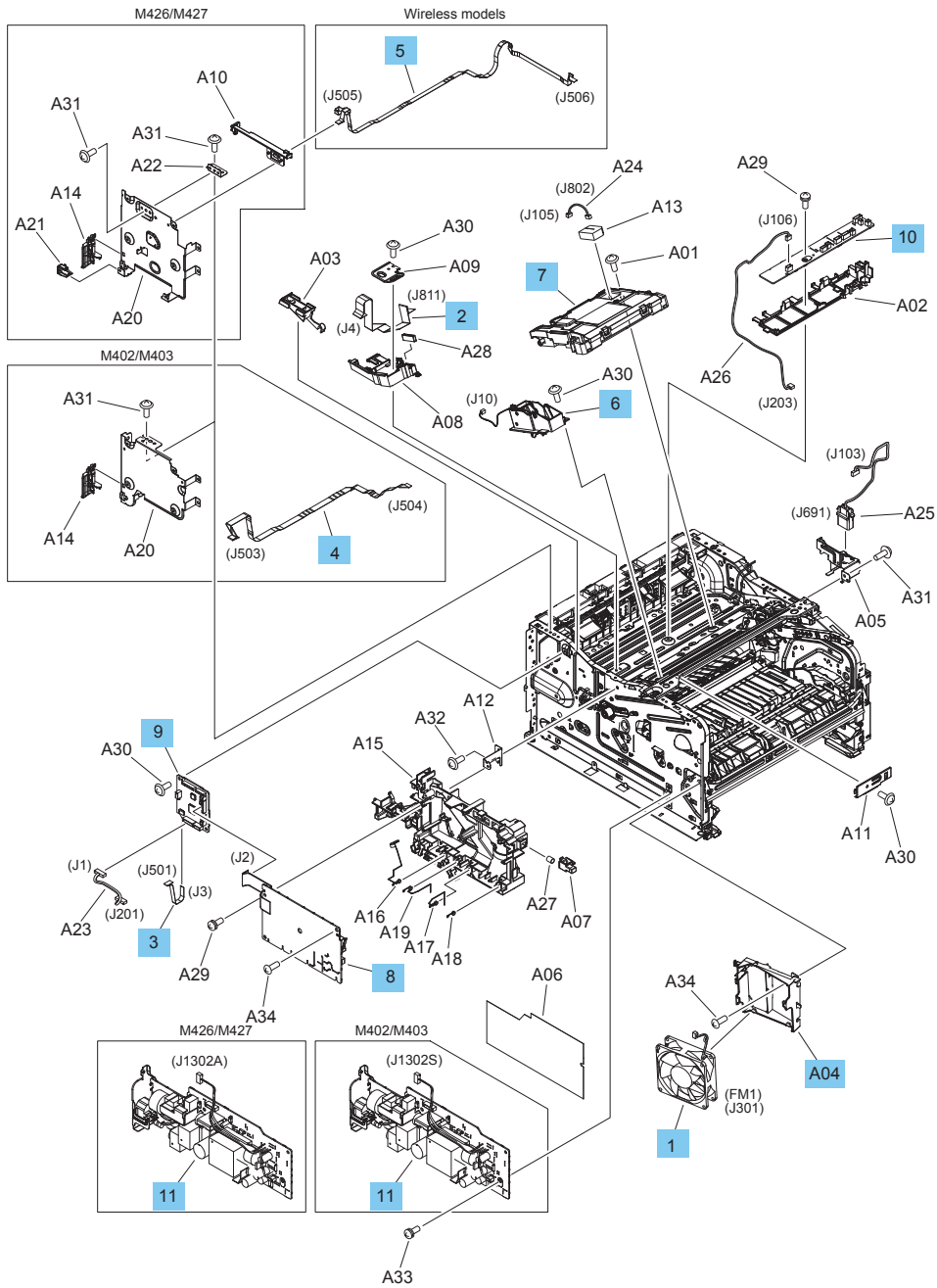

Table 2-6 Internal components, printer base (1 of 3)

Ref	Description	Part number	Qty
1	Fan, FM1	RK2-8068-000CN	1
2	Cable, laser-scanner FFC	RK2-6919-000CN	1
3	Cable, formatter FFC (M246/M247)	RK2-6931-000CN	1
3	Cable, formatter FFC (M402/M403)	RK2-6920-000CN	1
4	Cable, panel FFC (M402/M403)	RK2-6943-000CN	1
5	Cable, Near field communication (NFC) FFC (wireless models M402/M403)	RK2-6947-000CN	1
5	Cable, Near field communication (NFC) FFC (wireless models M426/M427)	RK2-6949-000CN	1
6	Cable, tag assembly	RM2-5426-000CN	1
7	Laser-scanner assembly	RM2-5528-000CN	1
8	High-voltage power supply (HVPS) PCA	RM2-7508-000CN	1
9	DC controller PCA	RM2-8680-000CN	1
10	Connecting PCA (duplex models)	RM2-7510-000CN	1
10	Connecting PCA (simplex models)	RM2-8510-000CN	1
11	Low-voltage power supply (LVPS) PCA (110–127 V M426/M427)	RM2-8518-000CN	1
11	Low-voltage power supply (LVPS) PCA (220–240 V M426/M427)	RM2-8519-000CN	1
11	Low-voltage power supply (LVPS) PCA (110–127 V M402/M403)	RM2-8517-000CN	1
11	Low-voltage power supply (LVPS) PCA (220–240 V M402/M403)	RM2-8516-000CN	1
A04	Duct, fan	RC4-2891-000CN	1
Not shown	Duplex release button	RC2-6075-000CN	1
Not shown	Pad, thermal transfer	5851-6550	1
Not shown	Formatter PCA (M426dw; M427dw)	C5F99-60001	1
Not shown	Formatter PCA (M426fdn; M426fdw; M427fdn; M427fdw)	C5F98-60001	1
Not shown	Formatter PCA (M402d; M403d)	C5F92-60001	1
Not shown	Formatter PCA (M402n; M402dn; M403n; M403dn)	C5F93-60001	1
Not shown	Formatter PCA (M402dw; M403dw)	C5F94-60001	1
Not shown	Fax PCA (US/AP; M426fdn; M426fdw; 427fdn; M427fdw)	CF206-60001	1
Not shown	Fax PCA (Euro; M426fdn; M426fdw; 427fdn; M427fdw)	CF207-60001	1
Not shown	Fax PCA (Brazil; M426fdn; M426fdw; 427fdn; M427fdw)	CF208-60001	1
Not shown	Spacer, hexagonal fax (M426fdn; M426fdw; 427fdn; M427fdw)	C5F98-20001	1
Not shown	Wireless module	0960-3293	1
Not shown	Wireless holder	B3Q10-40054	1

Internal components, printer base (2 of 3)

Figure 2-5 Internal components, printer base (2 of 3)

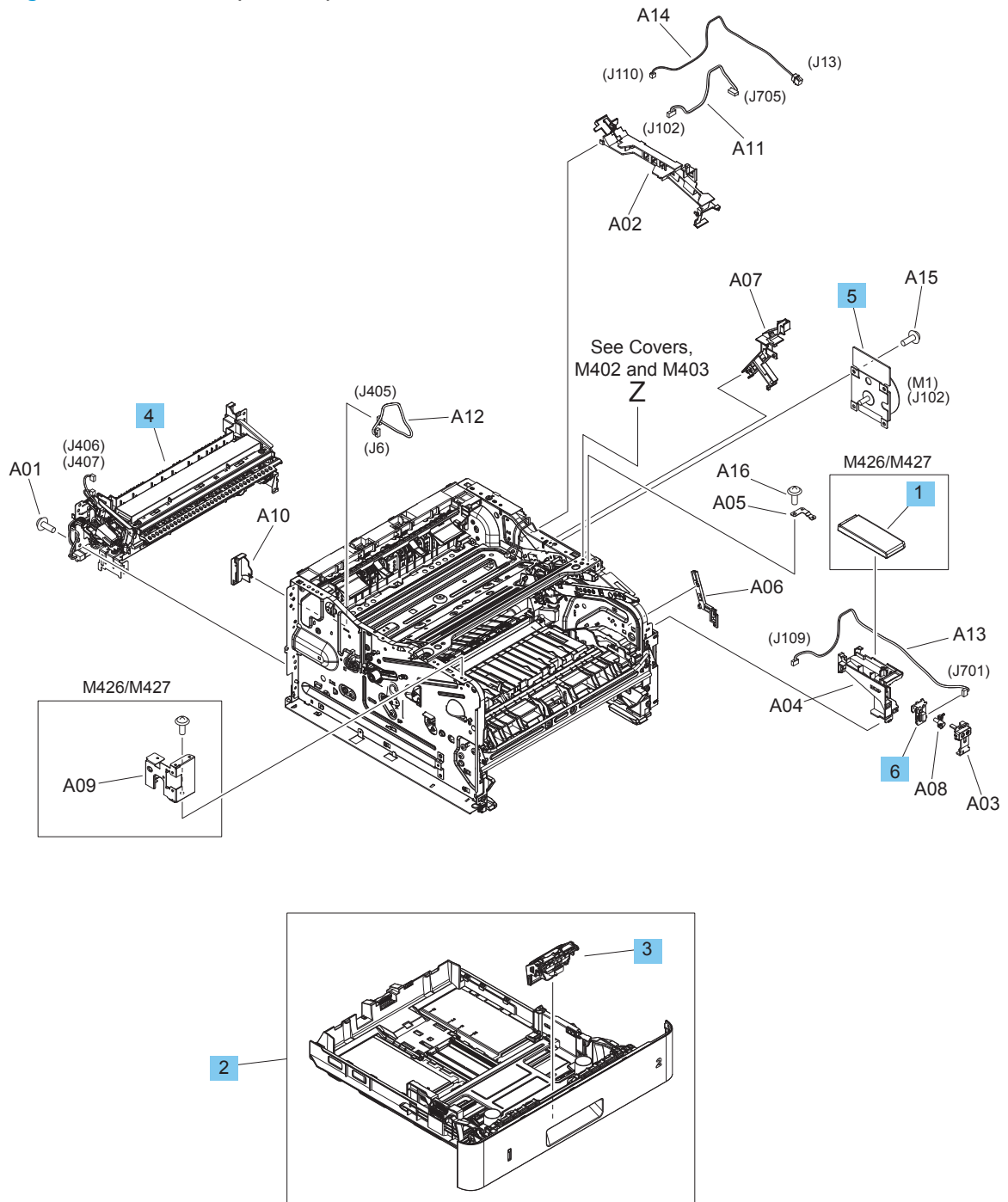

Table 2-7 Internal components, printer base (2 of 3)

Ref	Description	Part number	Qty
1	Cover, Near field communication (NFC) (M426/M427)	RC4-2961-000CN	1
2	Cassette (Tray 2) assembly	RM2-5392-000CN	1
3	Roller, separation assembly	RM2-5397-000CN	1
4	Fixing (fuser) assembly (110-127 V)	RM2-5399-000CN	1
4	Fixing (fuser) assembly (220-240 V)	RM2-5425-000CN	1
5	Main motor assembly	RM2-8684-000CN	1
6	Switch, power PCA	RM2-8506-000CN	1
Not shown	Ferrite, motor	9170-2659	1
Not shown	Walkup USB PCA (M426/M427)	CF368-60001	1
Not shown	Cable, walkup USB (M426/M427)	C5F98-60105	1
Not shown	NFC module	B4K93-60001	1

Internal components, printer base (3 of 3)

Figure 2-6 Internal components, printer base (3 of 3)

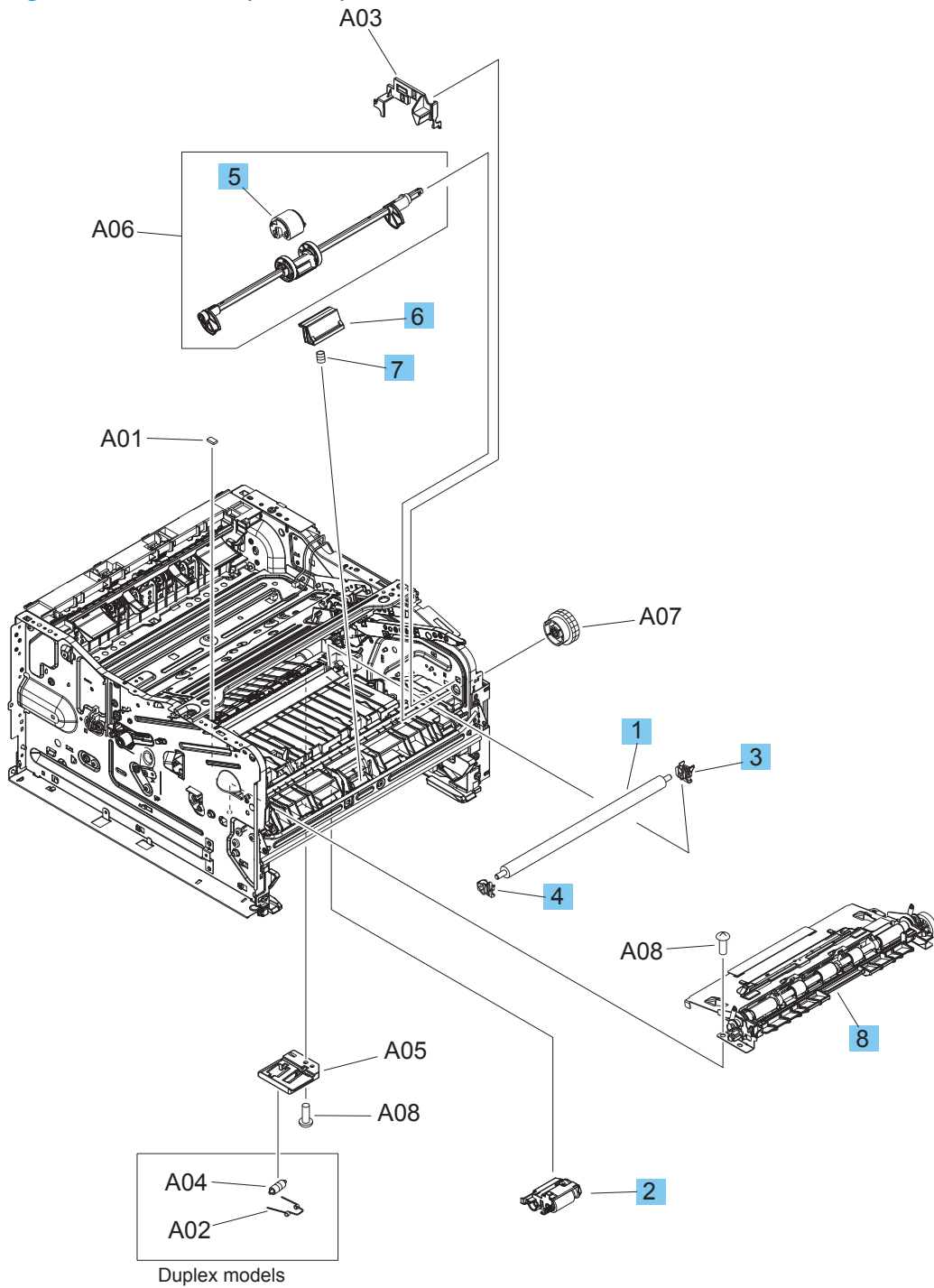

Table 2-8 Internal components, printer base (3 of 3)

Ref	Description	Part number	Qty
1	Roller, transfer	RM1-4023-000CN	1
2	Roller, paper pickup assembly	RM2-5452-000CN	1
3	Holder, transfer roller right	RC4-3133-000CN	1
4	Holder, transfer roller left	RC4-3134-000CN	1
5	Roller, multi-purpose (Tray 1)	RL2-0656-000CN	1
6	Pad, multi-purpose (Tray 1) separation	RL2-0657-000CN	1
7	Spring, compression	RU8-2935-000CN	1
8	Registration assembly	RM2-5671-000CN	1

550-sheet paper feeder

Covers, 550-sheet paper feeder

Figure 2-7 Covers, 550-sheet paper feeder

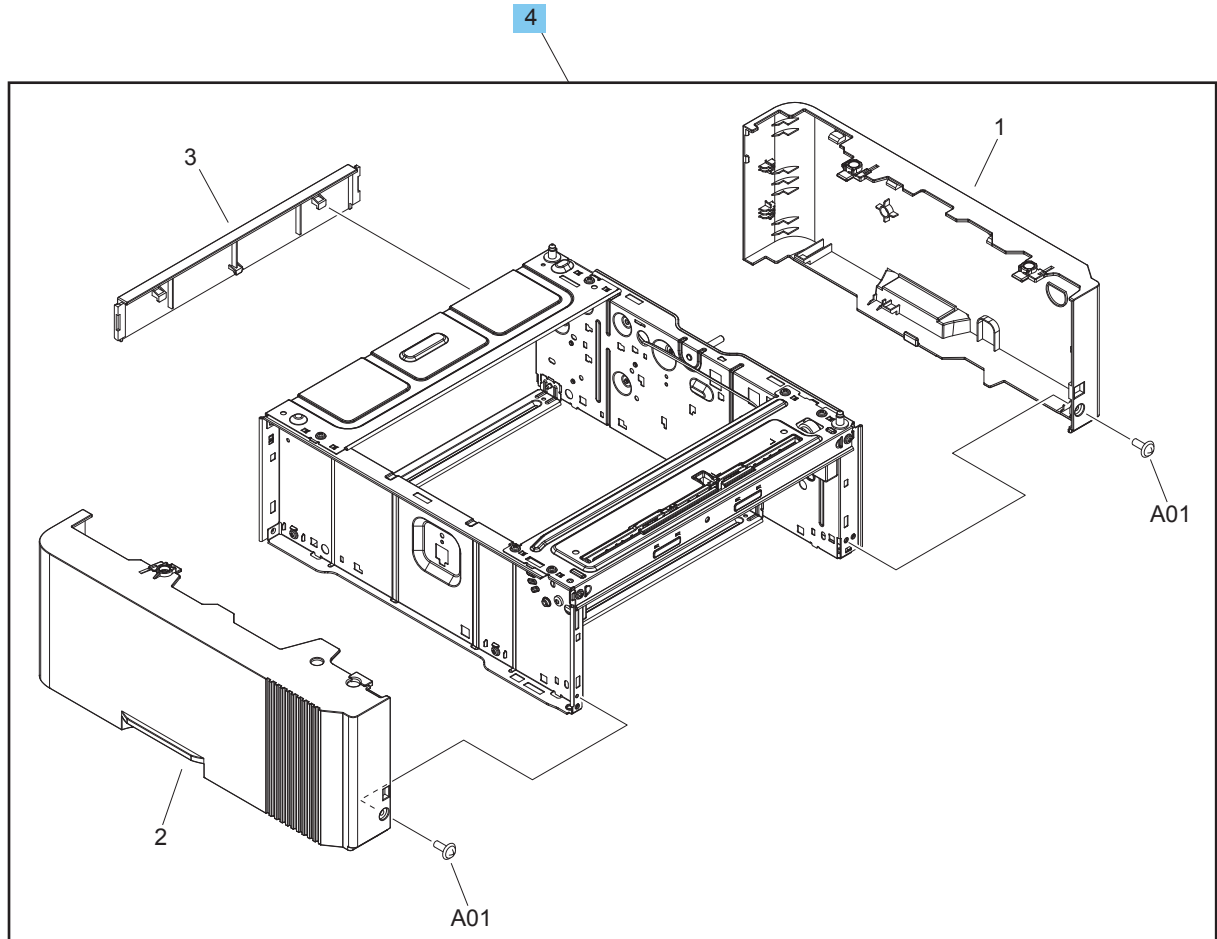

Table 2-9 Covers, 550-sheet paper feeder

Ref	Description	Part number	Qty
4	Paper feeder, 550-sheet assembly (whole unit)	C5F97-69001	1

Main body, 550-sheet paper feeder

Figure 2-8 Main body, 550-sheet paper feeder

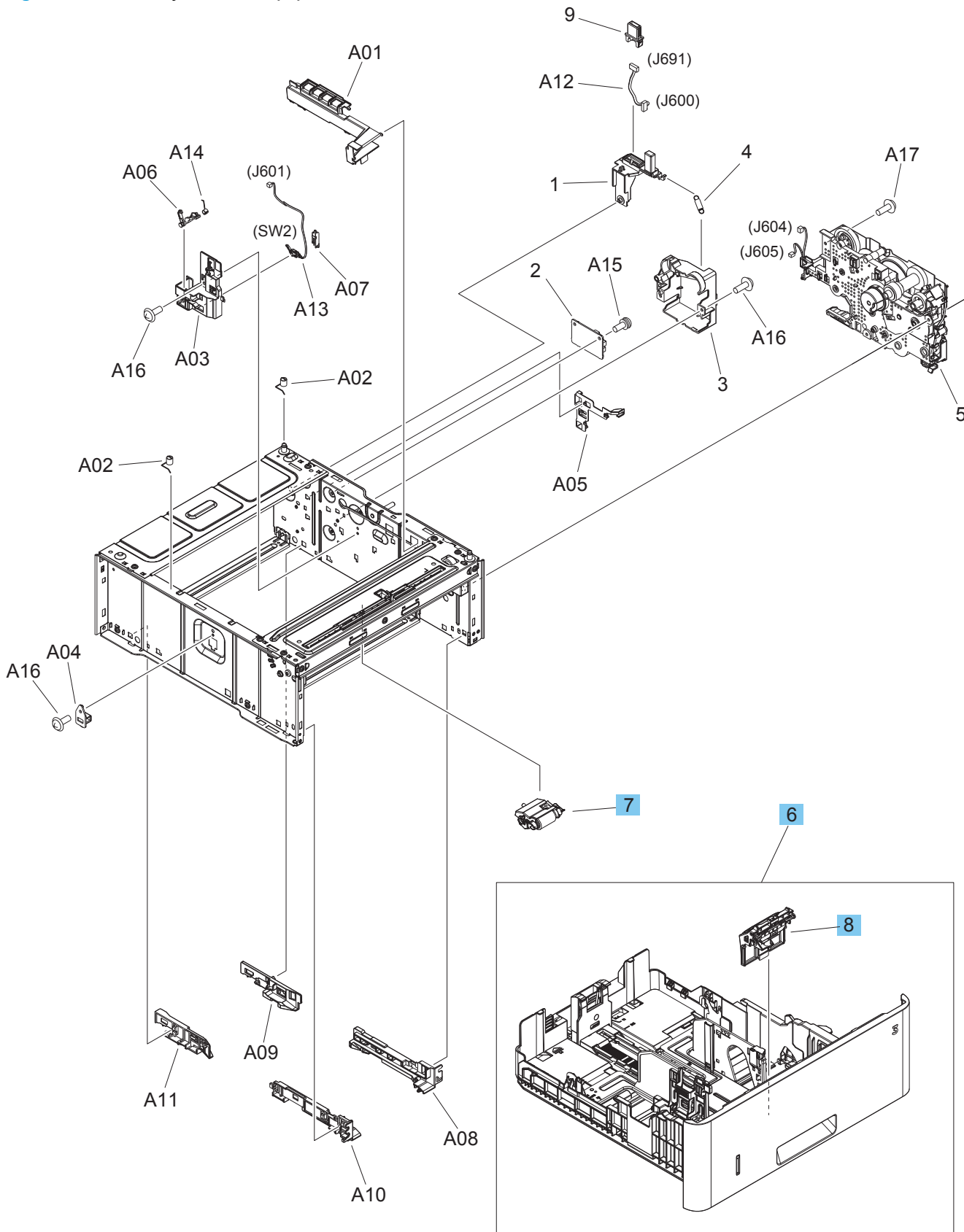

Table 2-10 Main body, 550-sheet paper feeder

Ref	Description	Part number	Qty
6	Cassette assembly (550-sheet feeder)	RM2-5413-000CN	1
7	Roller, paper pickup assembly (550-sheet feeder)	RM2-5741-000CN	1
8	Roller, separation assembly (550-sheet feeder)	RM2-5745-000CN	1

Alphabetical parts list

Table 2-11 Alphabetical parts list

Description	Part number	Table and page
ADF pick roller assembly	B3Q10-60105	Main assemblies (document feeder and image scanner) on page 1209
ADF separation pad	B3Q10-40080	Main assemblies (document feeder and image scanner) on page 1209
Cable, formatter FFC (M246/M247)	RK2-6931-000CN	Internal components, printer base (1 of 3) on page 1215
Cable, formatter FFC (M402/M403)	RK2-6920-000CN	Internal components, printer base (1 of 3) on page 1215
Cable, laser-scanner FFC	RK2-6919-000CN	Internal components, printer base (1 of 3) on page 1215
Cable, Near field communication (NFC) FFC (wireless models M402/M403)	RK2-6947-000CN	Internal components, printer base (1 of 3) on page 1215
Cable, Near field communication (NFC) FFC (wireless models M426/M427)	RK2-6949-000CN	Internal components, printer base (1 of 3) on page 1215
Cable, panel FFC (M402/M403)	RK2-6943-000CN	Internal components, printer base (1 of 3) on page 1215
Cable, tag assembly	RM2-5426-000CN	Internal components, printer base (1 of 3) on page 1215
Cable, walkup USB (M426/M427)	C5F98-60105	Internal components, printer base (2 of 3) on page 1217
Cartridge door assembly (NFC models M402/M403)	RM2-5436-000CN	Covers, M402 and M403 on page 1211
Cartridge door assembly (non-NFC models M402/M403)	RM2-5390-000CN	Covers, M402 and M403 on page 1211
Cassette (Tray 2) assembly	RM2-5392-000CN	Internal components, printer base (2 of 3) on page 1217
Cassette assembly (550-sheet feeder)	RM2-5413-000CN	Main body, 550-sheet paper feeder on page 1223
Connecting PCA (duplex models)	RM2-7510-000CN	Internal components, printer base (1 of 3) on page 1215
Connecting PCA (simplex models)	RM2-8510-000CN	Internal components, printer base (1 of 3) on page 1215
Control panel (M426/M427)	B3Q10-60139	Covers, M426 and M427 on page 1213
Control panel 22-pin FFC	C5F98-60104	Covers, M426 and M427 on page 1213
Control panel mount base	B3Q11-40001	Covers, M426 and M427 on page 1213
Control panel mount chassis assembly	B3Q10-60145	Covers, M426 and M427 on page 1213

Table 2-11 Alphabetical parts list (continued)

Description	Part number	Table and page
Control panel mount cover	B3Q11-40002	Covers, M426 and M427 on page 1213
Control-panel assembly (non-wireless models M402/M403)	RM2-5391-000CN	Covers, M402 and M403 on page 1211
Control-panel assembly (wireless models M402/M403)	RM2-5424-000CN	Covers, M402 and M403 on page 1211
Cover, ADF inner (under the out cover)	B3Q10-40012	Main assemblies (document feeder and image scanner) on page 1209
Cover, ADF outer	B3Q10-40013	Main assemblies (document feeder and image scanner) on page 1209
Cover, cassette rear	RC4-3082-000CN	Covers, M402 and M403 on page 1211
Cover, cassette rear	RC4-3082-000CN	Covers, M426 and M427 on page 1213
Cover, core	C5F98-40003	Main assemblies (document feeder and image scanner) on page 1209
Cover, fax port (M426fdn; M426fdw; 427fdn; M427fdw)	C5F99-40003	Covers, M426 and M427 on page 1213
Cover, FFC	C5F98-40002	Main assemblies (document feeder and image scanner) on page 1209
Cover, indication	RL2-0675-000CN	Covers, M402 and M403 on page 1211
Cover, left (M402/M403)	RL2-0673-000CN	Covers, M402 and M403 on page 1211
Cover, left (M426/M427)	RL2-0674-000CN	Covers, M426 and M427 on page 1213
Cover, Near field communication (NFC) (M426/M427)	RC4-2961-000CN	Internal components, printer base (2 of 3) on page 1217
Cover, network (non-network models M402/M403)	RC4-2907-000CN	Covers, M402 and M403 on page 1211
Cover, operation (non-wireless models M402/M403)	RC4-3312-000CN	Covers, M402 and M403 on page 1211
Cover, operation (wireless models M402/M403)	RC4-3322-000CN	Covers, M402 and M403 on page 1211
Cover, rear USB (M402/M403)	RC4-3298-000CN	Covers, M402 and M403 on page 1211
Cover, rear USB (M426 and M427)	RC4-3299-000CN	Covers, M426 and M427 on page 1213
Cover, right assembly	RM2-5434-000CN	Covers, M402 and M403 on page 1211

Table 2-11 Alphabetical parts list (continued)

Description	Part number	Table and page
Cover, right assembly	RM2-5434-000CN	Covers, M426 and M427 on page 1213
Cover, top (M402/M403)	RC4-2956-000CN	Covers, M402 and M403 on page 1211
Cover, top (M426/M427)	RC4-3207-000CN	Covers, M426 and M427 on page 1213
DC controller PCA	RM2-8680-000CN	Internal components, printer base (1 of 3) on page 1215
Document feeder and image scanner assembly (duplex models M426/M427)	C5F98-60110	Main assemblies (document feeder and image scanner) on page 1209
Document feeder and image scanner assembly (simplex models M426/M427)	C5F98-60109	Main assemblies (document feeder and image scanner) on page 1209
Door, cartridge assembly (NFC models M426/M427)	RM2-5435-000CN	Covers, M426 and M427 on page 1213
Door, cartridge assembly (non-NFC models M426/M427)	RM2-5408-000CN	Covers, M426 and M427 on page 1213
Door, rear (duplex models only)	RM2-5405-000CN	Covers, M426 and M427 on page 1213
Door, rear assembly (duplex models only)	RM2-5405-000CN	Covers, M402 and M403 on page 1211
Door, rear assembly (simplex models M402/M403)	RM2-5430-000CN	Covers, M402 and M403 on page 1211
Duct, fan	RC4-2891-000CN	Internal components, printer base (1 of 3) on page 1215
Duplex release button	RC2-6075-000CN	Internal components, printer base (1 of 3) on page 1215
Fan, FM1	RK2-8068-000CN	Internal components, printer base (1 of 3) on page 1215
Fax PCA (Brazil; M426fdn; M426fdw; 427fdn; M427fdw)	CF208-60001	Internal components, printer base (1 of 3) on page 1215
Fax PCA (Euro; M426fdn; M426fdw; 427fdn; M427fdw)	CF207-60001	Internal components, printer base (1 of 3) on page 1215
Fax PCA (US/AP; M426fdn; M426fdw; 427fdn; M427fdw)	CF206-60001	Internal components, printer base (1 of 3) on page 1215
Ferrite ISA (M426fdn; M426fdw; M427fdn; M427fdw)	9170-2664	Main assemblies (document feeder and image scanner) on page 1209
Ferrite, ISA	9170-2437	Main assemblies (document feeder and image scanner) on page 1209
Ferrite, motor	9170-2659	Main assemblies (document feeder and image scanner) on page 1209

Table 2-11 Alphabetical parts list (continued)

Description	Part number	Table and page
Ferrite, motor	9170-2659	Internal components, printer base (2 of 3) on page 1217
Fixing (fuser) assembly (110-127 V)	RM2-5399-000CN	Internal components, printer base (2 of 3) on page 1217
Fixing (fuser) assembly (220-240 V)	RM2-5425-000CN	Internal components, printer base (2 of 3) on page 1217
Formatter PCA (M402d; M403d)	C5F92-60001	Internal components, printer base (1 of 3) on page 1215
Formatter PCA (M402dw; M403dw)	C5F94-60001	Internal components, printer base (1 of 3) on page 1215
Formatter PCA (M402n; M402dn; M403n; M403dn)	C5F93-60001	Internal components, printer base (1 of 3) on page 1215
Formatter PCA (M426dw; M427dw)	C5F99-60001	Internal components, printer base (1 of 3) on page 1215
Formatter PCA (M426fdn; M426fdw; M427fdn; M427fdw)	C5F98-60001	Internal components, printer base (1 of 3) on page 1215
Guide, cable	RC4-3217-000CN	Covers, M426 and M427 on page 1213
Guide, LED light	RC4-3311-000CN	Covers, M402 and M403 on page 1211
High-voltage power supply (HVPS) PCA	RM2-7508-000CN	Internal components, printer base (1 of 3) on page 1215
Holder, transfer roller left	RC4-3134-000CN	Internal components, printer base (3 of 3) on page 1219
Holder, transfer roller right	RC4-3133-000CN	Internal components, printer base (3 of 3) on page 1219
HP logo jewel	7121-8686	Covers, M402 and M403 on page 1211
HP logo jewel	7121-8686	Covers, M426 and M427 on page 1213
ISA lift	B3Q10-60128	Main assemblies (document feeder and image scanner) on page 1209
Laser-scanner assembly	RM2-5528-000CN	Internal components, printer base (1 of 3) on page 1215
Link, pressure release	RC4-4479-000CN	Covers, M402 and M403 on page 1211
Link, pressure release	RC4-4479-000CN	Covers, M426 and M427 on page 1213
Low-voltage power supply (LVPS) PCA (110-127 V M402/M403)	RM2-8517-000CN	Internal components, printer base (1 of 3) on page 1215
Low-voltage power supply (LVPS) PCA (110-127 V M426/M427)	RM2-8518-000CN	Internal components, printer base (1 of 3) on page 1215

Table 2-11 Alphabetical parts list (continued)

Description	Part number	Table and page
Low-voltage power supply (LVPS) PCA (220–240 V M402/M403)	RM2-8516-000CN	Internal components, printer base (1 of 3) on page 1215
Low-voltage power supply (LVPS) PCA (220–240 V M426/M427)	RM2-8519-000CN	Internal components, printer base (1 of 3) on page 1215
Main motor assembly	RM2-8684-000CN	Internal components, printer base (2 of 3) on page 1217
Name plate M426dw	F6W13-40002	Covers, M426 and M427 on page 1213
Name plate M426fdn	F6W14-40002	Covers, M426 and M427 on page 1213
Name plate M426fdw	F6W15-40002	Covers, M426 and M427 on page 1213
Name plate M427dn	C5F98-40004	Covers, M426 and M427 on page 1213
Name plate M427dw	C5F97-40001	Covers, M426 and M427 on page 1213
Name plate M427fdw	C5F99-40002	Covers, M426 and M427 on page 1213
NFC module	B4K93-60001	Internal components, printer base (2 of 3) on page 1217
Pad, multi-purpose (Tray 1) separation	RL2-0657-000CN	Internal components, printer base (3 of 3) on page 1219
Pad, thermal transfer	5851-6550	Internal components, printer base (1 of 3) on page 1215
Paper feeder, 550-sheet assembly (whole unit)	C5F97-69001	Covers, 550-sheet paper feeder on page 1221
Plate, name M402d	RC4-3288-000CN	Covers, M402 and M403 on page 1211
Plate, name M402dn	RC4-3264-000CN	Covers, M402 and M403 on page 1211
Plate, name M402dw	RC4-3265-000CN	Covers, M402 and M403 on page 1211
Plate, name M402n	RC4-3270-000CN	Covers, M402 and M403 on page 1211
Plate, name M403d	RC4-3266-000CN	Covers, M402 and M403 on page 1211
Plate, name M403dn	RC4-3268-000CN	Covers, M402 and M403 on page 1211
Plate, name M403dw	RC4-3269-000CN	Covers, M402 and M403 on page 1211
Plate, name M403n	RC4-3267-000CN	Covers, M402 and M403 on page 1211

Table 2-11 Alphabetical parts list (continued)

Description	Part number	Table and page
Registration assembly	RM2-5671-000CN	Internal components, printer base (3 of 3) on page 1219
Roller, multi-purpose (Tray 1)	RL2-0656-000CN	Internal components, printer base (3 of 3) on page 1219
Roller, paper pickup assembly	RM2-5452-000CN	Internal components, printer base (3 of 3) on page 1219
Roller, paper pickup assembly (550-sheet feeder)	RM2-5741-000CN	Main body, 550-sheet paper feeder on page 1223
Roller, separation assembly	RM2-5397-000CN	Internal components, printer base (2 of 3) on page 1217
Roller, separation assembly (550-sheet feeder)	RM2-5745-000CN	Main body, 550-sheet paper feeder on page 1223
Roller, transfer	RM1-4023-000CN	Internal components, printer base (3 of 3) on page 1219
Shaft, ADF pick extension	B3Q10-40081	Main assemblies (document feeder and image scanner) on page 1209
Shaft, support	RC4-3002-000CN	Covers, M402 and M403 on page 1211
Shaft, support	RC4-3002-000CN	Covers, M426 and M427 on page 1213
Sheet, damper	RC2-6075-000CN	Covers, M426 and M427 on page 1213
Sheet, damper (duplex models only)	RC2-6075-000CN	Covers, M402 and M403 on page 1211
Slider pin, ISA lift	B3Q10-40041	Main assemblies (document feeder and image scanner) on page 1209
Spacer, hexagonal fax (M426fdn; M426fdw; 427fdn; M427fdw)	C5F98-20001	Internal components, printer base (1 of 3) on page 1215
Spring, ADF separation pad (under the separation pad)	B3Q10-00019	Main assemblies (document feeder and image scanner) on page 1209
Spring, compression	RU8-2935-000CN	Internal components, printer base (3 of 3) on page 1219
Support, ADF separation pad	B3Q10-40079	Main assemblies (document feeder and image scanner) on page 1209
Switch, power PCA	RM2-8506-000CN	Internal components, printer base (2 of 3) on page 1217
Tray, paper delivery	RC4-3231-000CN	Covers, M402 and M403 on page 1211
Tray, paper delivery	RC4-3231-000CN	Covers, M426 and M427 on page 1213

Table 2-11 Alphabetical parts list (continued)

Description	Part number	Table and page
Walkup USB PCA (M426/M427)	CF368-60001	Internal components, printer base (2 of 3) on page 1217
Wireless holder	B3Q10-40054	Internal components, printer base (1 of 3) on page 1215
Wireless module	0960-3293	Internal components, printer base (1 of 3) on page 1215

Numerical parts list

Table 2-12 Numerical parts list

Part number	Description	Table and page
0960-3293	Wireless module	Internal components, printer base (1 of 3) on page 1215
5851-6550	Pad, thermal transfer	Internal components, printer base (1 of 3) on page 1215
7121-8686	HP logo jewel	Covers, M402 and M403 on page 1211
7121-8686	HP logo jewel	Covers, M426 and M427 on page 1213
9170-2437	Ferrite, ISA	Main assemblies (document feeder and image scanner) on page 1209
9170-2659	Ferrite, motor	Main assemblies (document feeder and image scanner) on page 1209
9170-2659	Ferrite, motor	Internal components, printer base (2 of 3) on page 1217
9170-2664	Ferrite ISA (M426fdn; M426fdw; M427fdn; M427fdw)	Main assemblies (document feeder and image scanner) on page 1209
B3Q10-00019	Spring, ADF separation pad (under the separation pad)	Main assemblies (document feeder and image scanner) on page 1209
B3Q10-40012	Cover, ADF inner (under the out cover)	Main assemblies (document feeder and image scanner) on page 1209
B3Q10-40013	Cover, ADF outer	Main assemblies (document feeder and image scanner) on page 1209
B3Q10-40041	Slider pin, ISA lift	Main assemblies (document feeder and image scanner) on page 1209
B3Q10-40054	Wireless holder	Internal components, printer base (1 of 3) on page 1215
B3Q10-40079	Support, ADF separation pad	Main assemblies (document feeder and image scanner) on page 1209
B3Q10-40080	ADF separation pad	Main assemblies (document feeder and image scanner) on page 1209
B3Q10-40081	Shaft, ADF pick extension	Main assemblies (document feeder and image scanner) on page 1209
B3Q10-60105	ADF pick roller assembly	Main assemblies (document feeder and image scanner) on page 1209

Table 2-12 Numerical parts list (continued)

Part number	Description	Table and page
B3Q10-60128	ISA lift	Main assemblies (document feeder and image scanner) on page 1209
B3Q10-60139	Control panel (M426/M427)	Covers, M426 and M427 on page 1213
B3Q10-60145	Control panel mount chassis assembly	Covers, M426 and M427 on page 1213
B3Q11-40001	Control panel mount base	Covers, M426 and M427 on page 1213
B3Q11-40002	Control panel mount cover	Covers, M426 and M427 on page 1213
B4K93-60001	NFC module	Internal components, printer base (2 of 3) on page 1217
C5F92-60001	Formatter PCA (M402d; M403d)	Internal components, printer base (1 of 3) on page 1215
C5F93-60001	Formatter PCA (M402n; M402dn; M403n; M403dn)	Internal components, printer base (1 of 3) on page 1215
C5F94-60001	Formatter PCA (M402dw; M403dw)	Internal components, printer base (1 of 3) on page 1215
C5F97-40001	Name plate M427dw	Covers, M426 and M427 on page 1213
C5F97-69001	Paper feeder, 550-sheet assembly (whole unit)	Covers, 550-sheet paper feeder on page 1221
C5F98-20001	Spacer, hexagonal fax (M426fdn; M426fdw; 427fdn; M427fdw)	Internal components, printer base (1 of 3) on page 1215
C5F98-40002	Cover, FFC	Main assemblies (document feeder and image scanner) on page 1209
C5F98-40003	Cover, core	Main assemblies (document feeder and image scanner) on page 1209
C5F98-40004	Name plate M427dn	Covers, M426 and M427 on page 1213
C5F98-60001	Formatter PCA (M426fdn; M426fdw; M427fdn; M427fdw)	Internal components, printer base (1 of 3) on page 1215
C5F98-60104	Control panel 22-pin FFC	Covers, M426 and M427 on page 1213
C5F98-60105	Cable, walkup USB (M426/M427)	Internal components, printer base (2 of 3) on page 1217
C5F98-60109	Document feeder and image scanner assembly (simplex models M426/M427)	Main assemblies (document feeder and image scanner) on page 1209
C5F98-60110	Document feeder and image scanner assembly (duplex models M426/M427)	Main assemblies (document feeder and image scanner) on page 1209

Table 2-12 Numerical parts list (continued)

Part number	Description	Table and page
C5F99-40002	Name plate M427fdw	Covers, M426 and M427 on page 1213
C5F99-40003	Cover, fax port (M426fdn; M426fdw; 427fdn; M427fdw)	Covers, M426 and M427 on page 1213
C5F99-60001	Formatter PCA (M426dw; M427dw)	Internal components, printer base (1 of 3) on page 1215
CF206-60001	Fax PCA (US/AP; M426fdn; M426fdw; 427fdn; M427fdw)	Internal components, printer base (1 of 3) on page 1215
CF207-60001	Fax PCA (Euro; M426fdn; M426fdw; 427fdn; M427fdw)	Internal components, printer base (1 of 3) on page 1215
CF208-60001	Fax PCA (Brazil; M426fdn; M426fdw; 427fdn; M427fdw)	Internal components, printer base (1 of 3) on page 1215
CF368-60001	Walkup USB PCA (M426/M427)	Internal components, printer base (2 of 3) on page 1217
F6W13-40002	Name plate M426dw	Covers, M426 and M427 on page 1213
F6W14-40002	Name plate M426fdn	Covers, M426 and M427 on page 1213
F6W15-40002	Name plate M426fdw	Covers, M426 and M427 on page 1213
RC2-6075-000CN	Sheet, damper (duplex models only)	Covers, M402 and M403 on page 1211
RC2-6075-000CN	Sheet, damper	Covers, M426 and M427 on page 1213
RC2-6075-000CN	Duplex release button	Internal components, printer base (1 of 3) on page 1215
RC4-2891-000CN	Duct, fan	Internal components, printer base (1 of 3) on page 1215
RC4-2907-000CN	Cover, network (non-network models M402/M403)	Covers, M402 and M403 on page 1211
RC4-2956-000CN	Cover, top (M402/M403)	Covers, M402 and M403 on page 1211
RC4-2961-000CN	Cover, Near field communication (NFC) (M426/M427)	Internal components, printer base (2 of 3) on page 1217
RC4-3002-000CN	Shaft, support	Covers, M402 and M403 on page 1211
RC4-3002-000CN	Shaft, support	Covers, M426 and M427 on page 1213
RC4-3082-000CN	Cover, cassette rear	Covers, M402 and M403 on page 1211
RC4-3082-000CN	Cover, cassette rear	Covers, M426 and M427 on page 1213

Table 2-12 Numerical parts list (continued)

Part number	Description	Table and page
RC4-3133-000CN	Holder, transfer roller right	Internal components, printer base (3 of 3) on page 1219
RC4-3134-000CN	Holder, transfer roller left	Internal components, printer base (3 of 3) on page 1219
RC4-3207-000CN	Cover, top (M426/M427)	Covers, M426 and M427 on page 1213
RC4-3217-000CN	Guide, cable	Covers, M426 and M427 on page 1213
RC4-3231-000CN	Tray, paper delivery	Covers, M402 and M403 on page 1211
RC4-3231-000CN	Tray, paper delivery	Covers, M426 and M427 on page 1213
RC4-3264-000CN	Plate, name M402dn	Covers, M402 and M403 on page 1211
RC4-3265-000CN	Plate, name M402dw	Covers, M402 and M403 on page 1211
RC4-3266-000CN	Plate, name M403d	Covers, M402 and M403 on page 1211
RC4-3267-000CN	Plate, name M403n	Covers, M402 and M403 on page 1211
RC4-3268-000CN	Plate, name M403dn	Covers, M402 and M403 on page 1211
RC4-3269-000CN	Plate, name M403dw	Covers, M402 and M403 on page 1211
RC4-3270-000CN	Plate, name M402n	Covers, M402 and M403 on page 1211
RC4-3288-000CN	Plate, name M402d	Covers, M402 and M403 on page 1211
RC4-3298-000CN	Cover, rear USB (M402/M403)	Covers, M402 and M403 on page 1211
RC4-3299-000CN	Cover, rear USB (M426 and M427)	Covers, M426 and M427 on page 1213
RC4-3311-000CN	Guide, LED light	Covers, M402 and M403 on page 1211
RC4-3312-000CN	Cover, operation (non-wireless models M402/M403)	Covers, M402 and M403 on page 1211
RC4-3322-000CN	Cover, operation (wireless models M402/M403)	Covers, M402 and M403 on page 1211
RC4-4479-000CN	Link, pressure release	Covers, M402 and M403 on page 1211
RC4-4479-000CN	Link, pressure release	Covers, M426 and M427 on page 1213

Table 2-12 Numerical parts list (continued)

Part number	Description	Table and page
RK2-6919-000CN	Cable, laser-scanner FFC	Internal components, printer base (1 of 3) on page 1215
RK2-6920-000CN	Cable, formatter FFC (M402/M403)	Internal components, printer base (1 of 3) on page 1215
RK2-6931-000CN	Cable, formatter FFC (M246/M247)	Internal components, printer base (1 of 3) on page 1215
RK2-6943-000CN	Cable, panel FFC (M402/M403)	Internal components, printer base (1 of 3) on page 1215
RK2-6947-000CN	Cable, Near field communication (NFC) FFC (wireless models M402/M403)	Internal components, printer base (1 of 3) on page 1215
RK2-6949-000CN	Cable, Near field communication (NFC) FFC (wireless models M426/M427)	Internal components, printer base (1 of 3) on page 1215
RK2-8068-000CN	Fan, FM1	Internal components, printer base (1 of 3) on page 1215
RL2-0656-000CN	Roller, multi-purpose (Tray 1)	Internal components, printer base (3 of 3) on page 1219
RL2-0657-000CN	Pad, multi-purpose (Tray 1) separation	Internal components, printer base (3 of 3) on page 1219
RL2-0673-000CN	Cover, left (M402/M403)	Covers, M402 and M403 on page 1211
RL2-0674-000CN	Cover, left (M426/M427)	Covers, M426 and M427 on page 1213
RL2-0675-000CN	Cover, indication	Covers, M402 and M403 on page 1211
RM1-4023-000CN	Roller, transfer	Internal components, printer base (3 of 3) on page 1219
RM2-5390-000CN	Cartridge door assembly (non-NFC models M402/M403)	Covers, M402 and M403 on page 1211
RM2-5391-000CN	Control-panel assembly (non-wireless models M402/M403)	Covers, M402 and M403 on page 1211
RM2-5392-000CN	Cassette (Tray 2) assembly	Internal components, printer base (2 of 3) on page 1217
RM2-5397-000CN	Roller, separation assembly	Internal components, printer base (2 of 3) on page 1217
RM2-5399-000CN	Fixing (fuser) assembly (110-127 V)	Internal components, printer base (2 of 3) on page 1217
RM2-5405-000CN	Door, rear assembly (duplex models only)	Covers, M402 and M403 on page 1211
RM2-5405-000CN	Door, rear (duplex models only)	Covers, M426 and M427 on page 1213
RM2-5408-000CN	Door, cartridge assembly (non-NFC models M426/M427)	Covers, M426 and M427 on page 1213

Table 2-12 Numerical parts list (continued)

Part number	Description	Table and page
RM2-5413-000CN	Cassette assembly (550-sheet feeder)	Main body, 550-sheet paper feeder on page 1223
RM2-5424-000CN	Control-panel assembly (wireless models M402/M403)	Covers, M402 and M403 on page 1211
RM2-5425-000CN	Fixing (fuser) assembly (220–240 V)	Internal components, printer base (2 of 3) on page 1217
RM2-5426-000CN	Cable, tag assembly	Internal components, printer base (1 of 3) on page 1215
RM2-5430-000CN	Door, rear assembly (simplex models M402/M403)	Covers, M402 and M403 on page 1211
RM2-5434-000CN	Cover, right assembly	Covers, M402 and M403 on page 1211
RM2-5434-000CN	Cover, right assembly	Covers, M426 and M427 on page 1213
RM2-5435-000CN	Door, cartridge assembly (NFC models M426/M427)	Covers, M426 and M427 on page 1213
RM2-5436-000CN	Cartridge door assembly (NFC models M402/M403)	Covers, M402 and M403 on page 1211
RM2-5452-000CN	Roller, paper pickup assembly	Internal components, printer base (3 of 3) on page 1219
RM2-5528-000CN	Laser-scanner assembly	Internal components, printer base (1 of 3) on page 1215
RM2-5671-000CN	Registration assembly	Internal components, printer base (3 of 3) on page 1219
RM2-5741-000CN	Roller, paper pickup assembly (550-sheet feeder)	Main body, 550-sheet paper feeder on page 1223
RM2-5745-000CN	Roller, separation assembly (550-sheet feeder)	Main body, 550-sheet paper feeder on page 1223
RM2-7508-000CN	High-voltage power supply (HVPS) PCA	Internal components, printer base (1 of 3) on page 1215
RM2-7510-000CN	Connecting PCA (duplex models)	Internal components, printer base (1 of 3) on page 1215
RM2-8506-000CN	Switch, power PCA	Internal components, printer base (2 of 3) on page 1217
RM2-8510-000CN	Connecting PCA (simplex models)	Internal components, printer base (1 of 3) on page 1215
RM2-8516-000CN	Low-voltage power supply (LVPS) PCA (220–240 V M402/M403)	Internal components, printer base (1 of 3) on page 1215
RM2-8517-000CN	Low-voltage power supply (LVPS) PCA (110–127 V M402/M403)	Internal components, printer base (1 of 3) on page 1215
RM2-8518-000CN	Low-voltage power supply (LVPS) PCA (110–127 V M426/M427)	Internal components, printer base (1 of 3) on page 1215

Table 2-12 Numerical parts list (continued)

Part number	Description	Table and page
RM2-8519-000CN	Low-voltage power supply (LVPS) PCA (220–240 V M426/M427)	Internal components, printer base (1 of 3) on page 1215
RM2-8680-000CN	DC controller PCA	Internal components, printer base (1 of 3) on page 1215
RM2-8684-000CN	Main motor assembly	Internal components, printer base (2 of 3) on page 1217
RU8-2935-000CN	Spring, compression	Internal components, printer base (3 of 3) on page 1219

Index

Symbols/Numerics

- 2-line LCD operator and indication covers (M403/M402)
 - removing and replacing 232
- 2-line LCD operator and indication covers (M403/M402), removing and replacing 232
- 500-sheet feeder
 - parts lists and diagrams 1220
- 550-sheet paper feeder
 - removing and replacing 1181
- 550-sheet paper feeder, removing and replacing 1181

A

- accessories
 - part numbers 1206
- after-service checklist 6

C

- cable guide (M427/M426)
 - removing and replacing 172
- cable guide (M427/M426), removing and replacing 172
- cartridge-door assembly
 - removing and replacing 57
- cartridge-door assembly, removing and replacing 57
- cartridges
 - ordering 1205
 - part numbers 1205
- cassette rear cover
 - removing and replacing 114
- cassette rear cover, removing and replacing 114
- cautions iii
- checklists
 - preservice 6

- connecting PCA
 - removing and replacing 824
- connecting PCA, removing and replacing 824
- control panel (M427/M426)
 - removing and replacing 1134
- control panel 22-pin FFC (M427/M426)
 - removing and replacing 1134
- control panel and control panel 22-pin FFC (M427/M426), removing and replacing 1134
- control panel and control panel sub assemblies (M427/M426), removing and replacing 1134
- control panel FFC (M403/M402)
 - removing and replacing 656
- control panel FFC (M403/M402), removing and replacing 656
- control panel mount base (M427/M426)
 - removing and replacing 1134
- control panel mount base (M427/M426), removing and replacing 1134
- control panel mount chassis assembly (M427/M426)
 - removing and replacing 1134
- control panel mount chassis assembly (M427/M426), removing and replacing 1134
- control panel mount cover (M427/M426)
 - removing and replacing 1134
- control panel mount cover (M427/M426), removing and replacing 1134
- conventions, document iii

- cover NFC
 - removing and replacing 1033
- cover NFC, removing and replacing 1033
- covers, printer base
 - parts lists and diagrams 1210

D

- damper sheets
 - removing and replacing 46
- damper sheets, removing and replacing 46
- DC controller
 - removing and replacing 724
- DC controller, removing and replacing 724
- document conventions iii
- document feeder
 - parts lists and diagrams 1208
- document feeder and image scanner
 - parts lists and diagrams 1208

E

- electrostatic discharge (ESD) 4
- ESD electrostatic discharge (ESD) 4

F

- fan (FM1)
 - removing and replacing 493
- fan (FM1), removing and replacing 493
- fan holder (FM1)
 - removing and replacing 507
- fan holder (FM1), removing and replacing 507
- fax PCA
 - removing and replacing 429
- FCC NFC
 - removing and replacing 609

- FCC NFC , removing and replacing 609
- FFC control panel (M403/M402)
 - removing and replacing 656
- FFC control panel (M403/M402), removing and replacing 656
- FFC laser scanner
 - removing and replacing 873
- FFC laser scanner, removing and replacing 873
- FFC, formatter
 - removing and replacing 678
- FFC, formatter, removing and replacing 678
- field-replaceable units (FRUs)
 - replacing 3
- flat-flexible cable, control panel (M403/M402)
 - removing and replacing 656
- flat-flexible cable, control panel (M403/M402), removing and replacing 656
- flat-flexible cable, formatter
 - removing and replacing 678
- flat-flexible cable, formatter, removing and replacing 678
- flat-flexible cable, laser scanner
 - removing and replacing 873
- flat-flexible cable, laser scanner, removing and replacing 873
- flat-flexible cable, near field communication
 - removing and replacing 609
- flat-flexible cable, removing and replacing 609
- formatter FFC
 - removing and replacing 678
- formatter FFC, removing and replacing 678
- formatter PCA
 - removing and replacing 474
- formatter PCA, removing and replacing 474
- FRUs (field-replaceable units)
 - replacing 3
- fuser
 - removing and replacing 325
- fuser, removing and replacing 325

- H**
- high-voltage power supply
 - removing and replacing 927
- high-voltage power supply, removing and replacing 927
- holder fan (FM1)
 - removing and replacing 507
- holder fan (FM1), removing and replacing 507
- HVPS
 - removing and replacing 927
- HVPS, removing and replacing 927
- I**
- I/O cover
 - removing and replacing 49
- I/O cover, removing and replacing 49
- image scanner
 - parts lists and diagrams 1208
- input/output cover
 - removing and replacing 49
- input/output cover, removing and replacing 49
- installation 5
 - screws 5
 - See also* replacing parts
- integrated scanner assembly (M427/M426)
 - removing and replacing 294
- integrated scanner assembly (M427/M426), removing and replacing 294
- internal components, printer
 - parts lists and diagrams 1214
- ISA
 - removing and replacing 294
- ISA (M427/M426), removing and replacing 294
- ISA lift assembly and slider pin
 - removing and replacing 316
- ISA lift assembly and slider pin (M427/M426)
 - removing and replacing 316
- ISA lift assembly and slider pin (M427/M426), removing and replacing 316

- L**
- laser scanner
 - warnings for servicing 3
- laser scanner assembly
 - removing and replacing 525
- laser scanner assembly, removing and replacing 525
- laser scanner FFC
 - removing and replacing 873
- laser scanner FFC, removing and replacing 873
- left cover
 - removing and replacing 73
- left cover, removing and replacing 73
- low-voltage power supply
 - removing and replacing 977
- low-voltage power supply, removing and replacing 977
- LVPS
 - removing and replacing 977
- LVPS, removing and replacing 977
- M**
- main motor (M1)
 - removing and replacing 402
- main motor (M1), removing and replacing 402
- maintenance kits
 - part numbers 1206
- multipurpose tray (Tray 1) roller
 - removing and replacing 8
- multipurpose tray (Tray 1) roller, removing and replacing 8
- N**
- near field communication PCA
 - removing and replacing 1070
- near field communication PCA cover
 - removing and replacing 1033
- near field communication PCA cover, removing and replacing 1033
- near field communication PCA, removing and replacing 1070
- NFC
 - removing and replacing 1070
- NFC FCC, removing and replacing 609
- NFC, removing and replacing 1070
- notes iii

O

optional Tray 3 paper pickup roller assembly (Tray 3), removing and replacing 27, 1190
 ordering
 toner cartridges and accessories 1205
 output bin
 removing and replacing 253
 output bin, removing and replacing 253

P

paper delivery tray (output bin)
 removing and replacing 253
 paper delivery tray (output bin), removing and replacing 253
 paper pickup roller assembly (Tray 2)
 removing and replacing 20, 1168
 paper pickup roller assembly (Tray 2), removing and replacing 20, 1168
 paper pickup roller assembly (Tray 3)
 removing and replacing 27, 1190
 paper pickup roller assembly (Tray 3), removing and replacing 27, 1190
 part numbers
 accessories 1206
 replacement parts 1206
 staple cartridges 1206
 supplies 1206
 toner cartridge 1206
 toner cartridges 1205
 parts lists and diagrams 1203
 500-sheet feeder 1220
 covers, printer base 1210
 document feeder and image scanner 1208
 internal components, printer 1214
 using 1207
 PCA connecting
 removing and replacing 824
 PCA connecting, removing and replacing 824
 PCA power switch
 removing and replacing 414
 PCA power switch, removing and replacing 414

post-service tests 6
 power switch printed circuit assembly
 removing and replacing 414
 power switch printed circuit assembly, removing and replacing 414
 preservice checklist 6
 pressure-release link
 removing and replacing 64
 pressure-release link, removing and replacing 64
 print quality
 test 6

R

rear door assembly
 removing and replacing 98
 rear door assembly, removing and replacing 98
 registration assembly
 removing and replacing 347
 registration assembly, removing and replacing 347
 removal strategy
 removing and replacing 3
 removing and replacing
 2-line LCD operator and indication covers (M403/M402) 232
 550-sheet paper feeder 1181
 cable guide (M427/M426) 172
 cartridge-door assembly 57
 cassette rear cover 114
 connecting PCA 824
 control panel and control panel sub assemblies (M427/M426) 1134
 control panel FFC (M403/M402) 656
 cover NFC 1033
 damper sheets 46
 DC controller 724
 fan (FM1) 493
 fan holder (FM1) 507
 fax PCA 429
 FFC control panel (M403/M402) 656
 FFC laser scanner 873
 FFC, formatter 678
 flat-flexible cable, control panel (M403/M402) 656

flat-flexible cable, formatter 678
 flat-flexible cable, laser scanner 873
 flat-flexible cable, near field communication 609
 formatter FFC 678
 formatter PCA 474
 fuser 325
 high-voltage power supply 927
 HVPS 927
 I/O cover 49
 input/output cover 49
 integrated scanner assembly (M427/M426) 294
 ISA (M427/M426) 294
 ISA lift assembly and slider pin (M427/M426) 316
 laser scanner assembly 525
 laser scanner FFC 873
 left cover 73
 low-voltage power supply 977
 LVPS 977
 main motor (M1) 402
 multipurpose tray (Tray 1) roller 8
 near field communication PCA 1070
 near field communication PCA cover 1033
 NFC 1070
 NFC FCC 609
 output bin 253
 paper delivery tray (output bin) 253
 paper pickup roller assembly (Tray 2) 20, 1168
 paper pickup roller assembly (Tray 3) 27, 1190
 PCA connecting 824
 PCA power switch 414
 power switch printed circuit assembly 414
 pressure-release link 64
 rear door assembly 98
 registration assembly 347
 right cover 87
 roller MP tray (Tray 1) 8
 separation roller assembly (Tray 2) 34, 1175

- separation roller assembly (Tray 3) 39, 1197
- sheet-metal formatter bracket and formatter PCA 567
- support shaft 53
- tag-cable assembly (toner-cartridge memory) 776
- toner-cartridge memory (tag-cable assembly) 776
- top cover (M403/M402) 211
- top cover (M427/M426) 133
- Tray 1 roller 8
- Tray 2 13, 1165, 1166
- Tray 2 paper pickup roller assembly 20, 1168
- Tray 3 16, 1186
- walkup USB PCA 443
- wireless PCA 460
- removing parts
 - after-service checklist 6
 - checklists 6
 - tools, required 4
- replacement parts
 - part numbers 1206
- replacing
 - parts 3
- replacing parts
 - about 3
 - after-service checklist 6
 - screws 5
 - tools, required 4
- right cover
 - removing and replacing 87
- right cover, removing and replacing 87
- roller MP tray (Tray 1)
 - removing and replacing 8
- roller MP tray (Tray 1), removing and replacing 8

S

- screwdrivers, required 4
- screws
 - installing 5
 - replacing 4
 - types of 5
- separation roller assembly (Tray 2)
 - removing and replacing 34, 1175

- separation roller assembly (Tray 2), removing and replacing 34, 1175
- separation roller assembly (Tray 3)
 - removing and replacing 39, 1197
- separation roller assembly (Tray 3), removing and replacing 39, 1197
- service and support information v, 2, 1204
- service approach
 - removing and replacing 6
- sheet-metal formatter bracket and formatter PCA
 - removing and replacing 567
- sheet-metal formatter bracket and formatter PCA, removing and replacing 567
- staple cartridges
 - part numbers 1206
- static, precautions for 4
- supplies
 - part numbers 1206
- support shaft
 - removing and replacing 53
- support shaft, removing and replacing 53

T

- tag-cable assembly (toner-cartridge memory)
 - removing and replacing 776
- tag-cable assembly (toner-cartridge memory), removing and replacing 776
- tests
 - post-service 6
 - print-quality 6
- tips iii
- toner cartridge
 - part numbers 1206
- toner cartridges
 - ordering 1205
 - part numbers 1205
- toner-cartridge memory (tag-cable assembly)
 - removing and replacing 776
- toner-cartridge memory (tag-cable assembly), removing and replacing 776
- tools, required 4

- top cover (M403/M402)
 - removing and replacing 211
- top cover (M403/M402), removing and replacing 211
- top cover (M427/M426)
 - removing and replacing 133
- top cover (M427/M426), removing and replacing 133
- Tray 1 roller
 - removing and replacing 8
- Tray 1 roller, removing and replacing 8
- Tray 2
 - removing and replacing 13, 1165, 1166
- Tray 2 paper pickup roller assembly
 - removing and replacing 20, 1168
- Tray 2 paper pickup roller assembly, removing and replacing 20, 1168
- Tray 2, removing and replacing 13, 1165, 1166
- Tray 3
 - removing and replacing 16, 1186
- Tray 3, removing and replacing 16, 1186

W

- walkup USB PCA
 - removing and replacing 443
- warnings iii
- wireless PCA
 - removing and replacing 460