



LASERJET PRO 500 COLOR MFP

Repair Manual



M570



HP LaserJet Pro 500 color MFP M570 Printers

Repair Manual

Copyright and License

© 2012 Copyright Hewlett-Packard
Development Company, L.P.

Reproduction, adaptation, or translation
without prior written permission is
prohibited, except as allowed under the
copyright laws.

The information contained herein is subject
to change without notice.

The only warranties for HP products and
services are set forth in the express warranty
statements accompanying such products and
services. Nothing herein should be
construed as constituting an additional
warranty. HP shall not be liable for technical
or editorial errors or omissions contained
herein.

Edition 1, 11/2012

Part number: CZ271-91020

Conventions used in this guide

 **TIP:** Tips provide helpful hints or shortcuts.

 **NOTE:** Notes provide important information to explain a concept or to complete a task.

 **CAUTION:** Cautions indicate procedures that you should follow to avoid losing data or damaging the product.

 **WARNING!** Warnings alert you to specific procedures that you should follow to avoid personal injury, catastrophic loss of data, or extensive damage to the product.

Table of contents

1 Removal and replacement	1
Introduction	2
Removal and replacement strategy	2
General cautions during removal and replacement	2
Electrostatic discharge	3
Required tools	3
Types of screws	4
Service approach	5
Before performing service	5
After performing service	5
Post-service test	6
Print-quality test	6
Copy-quality test	6
DC controller PCA	7
Parts removal order	8
Removal and replacement procedures	9
Customer self repair (CSR) components	9
Toner cartridges	9
Duplex-reverse guide	11
Toner-collection unit	12
Tray 2 and 3	14
Pickup roller and separation pad (Tray 1)	15
Pickup roller (Tray 2)	17
Pickup and feed rollers (Tray 3)	19
Separation roller (Tray 2)	21
Secondary transfer roller	22
Reinstall the transfer roller	23
Intermediate transfer belt (ITB)	24
Front-door assembly	27
Document feeder pickup rollers	28
Document feeder separation pad	31
Control panel	32

Remove the control panel	32
USB PCA	36
Remove the USB PCA	36
Control panel friction mount	38
Remove the control panel friction mount	38
Right door (optional paper feeder)	39
External panels, covers, and doors	41
Identification and location	41
Front-upper cover	42
Remove the front-upper cover	42
Right-door assembly	44
Right-rear cover	48
Left cover	50
Rear-upper cover	53
Left-upper cover	54
Remove the left-upper cover	54
Right-upper rear cover	55
Remove the right-upper cover	55
Rear cover	56
Remove the rear cover	56
Right-front cover	58
Remove the right-front cover	58
Delivery cover	62
Remove the delivery cover	62
Right-top cover	64
Remove the right-top cover	64
Upper-right cover	66
Remove the upper-right cover	66
Front-top cover	69
Remove the front-top cover	69
Rear-top cover	71
Remove the rear-top cover	72
Document feeder and scanner	73
Document feeder	73
Reinstall the document feeder	76
Image scanner	77
Remove the image scanner	77
Reinstall the image scanner	80
Internal assemblies	81
Fuser	81
Formatter PCA	83

Remove the formatter PCA	83
Fax PCA	85
Remove the fax PCA and cable	85
Wireless PCA	87
Remove the wireless PCA	87
Interconnect board (ICB)	88
Remove the ICB	88
DC controller PCA and tray	91
Remove the DC controller PCA and tray	91
Low-voltage power supply (LVPS)	94
Remove the LVPS	94
Delivery fan, cartridge fan, and environmental sensor	99
Remove the delivery fan, cartridge fan, and environmental sensor ...	99
Toner-collection sensor	104
Remove the toner-collection sensor	104
Residual-toner-feed motor	107
Remove the residual-toner-feed motor	107
Secondary transfer assembly	112
Reinstall the secondary transfer assembly	113
Lower pickup guide	114
Remove the lower pickup guide	114
Reinstall the lower pickup guide	116
Registration density (RD) sensor assembly	117
Remove the RD sensor assembly	117
Power-supply fan and fan duct	121
Remove the power-supply fan and fan duct	121
Registration assembly	124
Remove the registration assembly	124
High-voltage power supply lower	129
Remove the high-voltage power supply lower	129
Developing-disengagement motor	132
Remove the developing-disengagement motor	132
Pickup motor	134
Remove the pickup motor	134
Lifter-drive assembly	135
Remove the lifter-drive assembly	135
Tray-pickup drive assembly	137
Remove the tray-pickup drive assembly	137
Tray-pickup assembly	144
Remove the tray-pickup assembly	144
Laser/scanner assembly (Y/M)	146

Remove the laser/scanner assembly (Y/M)	146
Laser/scanner assembly (C/Bk)	153
Remove the laser/scanner assembly (C/Bk)	154
High-voltage power supply upper	161
Remove the high-voltage power supply upper	161
Drum motor 1	165
Remove the drum motor 1	165
Drum motor 2 or drum motor 3	166
Remove the drum motor 2 or drum motor 3	166
Fuser motor	167
Remove the fuser motor	167
Main-drive assembly	168
Remove the main-drive assembly	169
Fuser-drive assembly	179
Remove the fuser-drive assembly	180
Delivery assembly	184
Remove the delivery assembly	185
Duplex-drive assembly	189
Remove the duplex-drive assembly	190
Optional paper feeder assembly (Tray 3)	191
Drawer connector	191

2 Parts and diagrams 193

Order parts, accessories, and supplies	194
Orderable parts	195
Accessories	195
Print cartridges and toner collection unit	196
Customer self repair (CSR) and service kits	197
Whole unit replacement (WUR)	199
Service parts	200
Related documentation and software	202
Fasteners used in this product	202
How to use the parts lists and diagrams	203
Assembly locations	204
Base product (no optional trays or accessories)	204
Base product (optional trays or accessories)	205
Covers	206
Right-door assembly	208
Internal assemblies	210
Internal assemblies (1 of 6)	210
Internal assemblies (2 of 6)	212

Internal assemblies (3 of 6)	214
Internal assemblies (4 of 6)	216
Internal assemblies (5 of 6)	218
Internal assemblies (6 of 6)	220
Assessories	222
1 x 500-sheet paper feeder	222
Paper feeder covers	224
Paper feeder main body	226
Paper feeder tray	228
Paper feeder PCA	230
Alphabetical parts list	232
Numerical parts list	238

Index	245
--------------------	------------

List of tables

Table 1-1	DC controller connectors	7
Table 1-2	Product base, external panels, covers, doors; identification and location	41
Table 2-1	Accessories	195
Table 2-2	LaserJet Pro 500 Color MFP M570dn (WUR)	199
Table 2-3	LaserJet Pro 500 Color MFP M570dw (WUR)	199
Table 2-4	Service parts	200
Table 2-5	Related documentation and software	202
Table 2-6	Common fasteners	202
Table 2-7	Optional 500-sheet input tray	205
Table 2-8	External covers, panels, and doors	207
Table 2-9	Right-door assembly	209
Table 2-10	Internal assemblies (1 of 6)	211
Table 2-11	Internal assemblies (2 of 6)	213
Table 2-12	Internal assemblies (3 of 6)	215
Table 2-13	Internal assemblies (4 of 6)	217
Table 2-14	Internal assemblies (5 of 6)	219
Table 2-15	Internal assemblies (6 of 6)	221
Table 2-16	1 x 500-sheet paper feeder	223
Table 2-17	Paper feeder covers	225
Table 2-18	Paper feeder main body	227
Table 2-19	Tray	229
Table 2-20	Paper feeder PCA	231
Table 2-21	Alphabetical parts list	232
Table 2-22	Numerical parts list	238

List of figures

Figure 1-1	Phillips and Pozidriv screwdriver comparison	3
Figure 1-2	DC controller PCA	7
Figure 1-3	Remove the toner cartridge (1 of 2)	9
Figure 1-4	Remove the toner cartridge (2 of 2)	10
Figure 1-5	Remove the duplex-reverse guide (1 of 2)	11
Figure 1-6	Remove the duplex-reverse guide (2 of 2)	11
Figure 1-7	Remove the toner-collection unit (1 of 4)	12
Figure 1-8	Remove the toner-collection unit (2 of 4)	12
Figure 1-9	Remove the toner-collection unit (3 of 4)	13
Figure 1-10	Remove the toner-collection unit (4 of 4)	13
Figure 1-11	Remove Tray 2 and 3 (1 of 2)	14
Figure 1-12	Remove Tray 2 and 3 (2 of 2)	14
Figure 1-13	Remove the pickup roller and separation pad (Tray 1) (1 of 3)	15
Figure 1-14	Remove the pickup roller and separation pad (Tray 1) (2 of 3)	15
Figure 1-15	Remove the pickup roller and separation pad (Tray 1) (3 of 3)	16
Figure 1-16	Remove the pickup roller (Tray 2) (1 of 4)	17
Figure 1-17	Remove the pickup roller (Tray 2) (2 of 4)	17
Figure 1-18	Remove the pickup roller (Tray 2) (3 of 4)	18
Figure 1-19	Remove the pickup roller (Tray 2) (4 of 4)	18
Figure 1-20	Remove the pickup and feed rollers (Tray 3) (1 of 2)	19
Figure 1-21	Remove the pickup and feed rollers (Tray 3) (2 of 2)	20
Figure 1-22	Remove the separation roller (Tray 2)	21
Figure 1-23	Remove the transfer roller (1 of 3)	22
Figure 1-24	Remove the transfer roller (2 of 3)	22
Figure 1-25	Remove the transfer roller (3 of 3)	23
Figure 1-26	Reinstall the transfer roller	23
Figure 1-27	Remove the intermediate transfer belt (1 of 4)	24
Figure 1-28	Remove the intermediate transfer belt (2 of 4)	24
Figure 1-29	Remove the intermediate transfer belt (3 of 4)	25
Figure 1-30	Remove the intermediate transfer belt (4 of 4)	26
Figure 1-31	Remove the front-door assembly (1 of 2)	27
Figure 1-32	Remove the front-door assembly (2 of 2)	27

Figure 1-33	Remove the document feeder pickup rollers (1 of 5)	28
Figure 1-34	Remove the document feeder pickup rollers (2 of 5)	28
Figure 1-35	Remove the document feeder pickup rollers (3 of 5)	29
Figure 1-36	Remove the document feeder pickup rollers (4 of 5)	29
Figure 1-37	Remove the document feeder pickup rollers (5 of 5)	30
Figure 1-38	Remove the document feeder separation pad (1 of 2)	31
Figure 1-39	Remove the document feeder separation pad (2 of 2)	31
Figure 1-40	Remove the control panel (1 of 6)	32
Figure 1-41	Remove the control panel (2 of 6)	33
Figure 1-42	Remove the control panel (3 of 6)	33
Figure 1-43	Remove the control panel (4 of 6)	34
Figure 1-44	Remove the control panel (5 of 6)	34
Figure 1-45	Remove the control panel (6 of 6)	35
Figure 1-46	Remove the USB PCA (1 of 3)	36
Figure 1-47	Remove the USB PCA (2 of 3)	37
Figure 1-48	Remove the USB PCA (3 of 3)	37
Figure 1-49	Remove the control panel friction mount	38
Figure 1-50	Remove the right door; optional paper feeder (1 of 3)	39
Figure 1-51	Remove the right door; optional paper feeder (2 of 3)	39
Figure 1-52	Remove the right door; optional paper feeder (3 of 3)	40
Figure 1-53	Product base, external panels, covers, doors; identification and location	41
Figure 1-54	Remove the front-upper cover (1 of 4)	42
Figure 1-55	Remove the front-upper cover (2 of 4)	42
Figure 1-56	Remove the front-upper cover (3 of 4)	43
Figure 1-57	Remove the front-upper cover (4 of 4)	43
Figure 1-58	Remove the right-door assembly (1 of 8)	44
Figure 1-59	Remove the right-door assembly (2 of 8)	44
Figure 1-60	Remove the right-door assembly (3 of 8)	45
Figure 1-61	Remove the right-door assembly (4 of 8)	45
Figure 1-62	Remove the right-door assembly (5 of 8)	46
Figure 1-63	Remove the right-door assembly (6 of 8)	46
Figure 1-64	Remove the right-door assembly (7 of 8)	47
Figure 1-65	Remove the right-door assembly (8 of 8)	47
Figure 1-66	Remove the right-rear cover (1 of 3)	48
Figure 1-67	Remove the right-rear cover (2 of 3)	48
Figure 1-68	Remove the right-rear cover (3 of 3)	49
Figure 1-69	Remove the left cover (1 of 5)	50
Figure 1-70	Remove the left cover (2 of 5)	50
Figure 1-71	Remove the left cover (3 of 5)	51
Figure 1-72	Remove the left cover (4 of 5)	51
Figure 1-73	Remove the left cover (5 of 5)	52

Figure 1-74	Remove the rear-upper cover (1 of 2)	53
Figure 1-75	Remove the rear-upper cover (2 of 2)	53
Figure 1-76	Remove the left-upper cover	54
Figure 1-77	Remove the right-upper cover	55
Figure 1-78	Remove the rear cover (1 of 2)	56
Figure 1-79	Remove the rear cover (2 of 2)	57
Figure 1-80	Remove the right-front cover (1 of 5)	58
Figure 1-81	Remove the right-front cover (2 of 5)	59
Figure 1-82	Remove the right-front cover (3 of 5)	59
Figure 1-83	Remove the right-front cover (4 of 5)	60
Figure 1-84	Remove the right-front cover (5 of 5)	60
Figure 1-85	Reinstall the power button	61
Figure 1-86	Remove the delivery cover (1 of 3)	62
Figure 1-87	Remove the delivery cover (2 of 3)	63
Figure 1-88	Remove the delivery cover (3 of 3)	63
Figure 1-89	Remove the right-top cover (1 of 2)	64
Figure 1-90	Remove the right-top cover (2 of 2)	65
Figure 1-91	Remove the upper-right cover (1 of 5)	66
Figure 1-92	Remove the upper-right cover (2 of 5)	67
Figure 1-93	Remove the upper-right cover (3 of 5)	67
Figure 1-94	Remove the upper-right cover (4 of 5)	68
Figure 1-95	Remove the upper-right cover (5 of 5)	68
Figure 1-96	Remove the front-top cover (1 of 2)	69
Figure 1-97	Remove the front-top cover (2 of 2)	70
Figure 1-98	Remove the rear-top cover	72
Figure 1-99	Remove the document feeder assembly (1 of 4)	73
Figure 1-100	Remove the document feeder assembly (2 of 4)	74
Figure 1-101	Remove the document feeder assembly (3 of 4)	74
Figure 1-102	Remove the document feeder assembly (4 of 4)	75
Figure 1-103	Remove the image scanner (1 of 5)	77
Figure 1-104	Remove the image scanner (2 of 5)	78
Figure 1-105	Remove the image scanner (3 of 5)	78
Figure 1-106	Remove the image scanner (4 of 5)	79
Figure 1-107	Remove the image scanner (5 of 5)	79
Figure 1-108	Remove the fuser (1 of 2)	81
Figure 1-109	Remove the fuser (2 of 2)	82
Figure 1-110	Remove the formatter (1 of 2)	83
Figure 1-111	Remove the formatter (2 of 2)	84
Figure 1-112	Remove the fax PCA (1 of 2)	85
Figure 1-113	Remove the fax PCA (2 of 2)	86
Figure 1-114	Remove the wireless PCA	87

Figure 1-115	Remove the ICB (1 of 4)	88
Figure 1-116	Remove the ICB (2 of 4)	89
Figure 1-117	Remove the ICB (3 of 4)	89
Figure 1-118	Remove the ICB (4 of 4)	90
Figure 1-119	Remove the DC controller PCA and tray (1 of 4)	91
Figure 1-120	Remove the DC controller PCA and tray (2 of 4)	92
Figure 1-121	Remove the DC controller PCA and tray (3 of 4)	92
Figure 1-122	Remove the DC controller PCA and tray (4 of 4)	93
Figure 1-123	Remove the LVPS (1 of 8)	94
Figure 1-124	Remove the LVPS (2 of 8)	95
Figure 1-125	Remove the LVPS (3 of 8)	95
Figure 1-126	Remove the LVPS (4 of 8)	96
Figure 1-127	Remove the LVPS (5 of 8)	96
Figure 1-128	Remove the LVPS (6 of 8)	97
Figure 1-129	Remove the LVPS (7 of 8)	97
Figure 1-130	Remove the LVPS (8 of 8)	98
Figure 1-131	Remove the delivery fan, cartridge fan, and environmental sensor (1 of 9)	99
Figure 1-132	Remove the delivery fan, cartridge fan, and environmental sensor (2 of 9)	100
Figure 1-133	Remove the delivery fan, cartridge fan, and environmental sensor (3 of 9)	100
Figure 1-134	Remove the delivery fan, cartridge fan, and environmental sensor (4 of 9)	101
Figure 1-135	Remove the delivery fan, cartridge fan, and environmental sensor (5 of 9)	101
Figure 1-136	Remove the delivery fan, cartridge fan, and environmental sensor (6 of 9)	102
Figure 1-137	Remove the delivery fan, cartridge fan, and environmental sensor (7 of 9)	102
Figure 1-138	Remove the delivery fan, cartridge fan, and environmental sensor (8 of 9)	103
Figure 1-139	Remove the delivery fan, cartridge fan, and environmental sensor (9 of 9)	103
Figure 1-140	Remove the toner-collection sensor (1 of 4)	104
Figure 1-141	Remove the toner-collection sensor (2 of 4)	105
Figure 1-142	Remove the toner-collection sensor (3 of 4)	105
Figure 1-143	Remove the toner-collection sensor (4 of 4)	106
Figure 1-144	Remove the residual-toner-feed motor (1 of 7)	107
Figure 1-145	Remove the residual-toner-feed motor (2 of 7)	108
Figure 1-146	Remove the residual-toner-feed motor (3 of 7)	108
Figure 1-147	Remove the residual-toner-feed motor (4 of 7)	109
Figure 1-148	Remove the residual-toner-feed motor (5 of 7)	109
Figure 1-149	Remove the residual-toner-feed motor (6 of 7)	110
Figure 1-150	Remove the residual-toner-feed motor (7 of 7)	110
Figure 1-151	Reinstall the residual-toner collection door	111
Figure 1-152	Remove the secondary transfer assembly (1 of 3)	112
Figure 1-153	Remove the secondary transfer assembly (2 of 3)	112
Figure 1-154	Remove the secondary transfer assembly (3 of 3)	113
Figure 1-155	Reinstall the secondary transfer assembly	113

Figure 1-156	Remove the lower pickup guide (1 of 4)	114
Figure 1-157	Remove the lower pickup guide (2 of 4)	114
Figure 1-158	Remove the lower pickup guide (3 of 4)	115
Figure 1-159	Remove the lower pickup guide (4 of 4)	115
Figure 1-160	Remove the RD sensor assembly (1 of 6)	117
Figure 1-161	Remove the RD sensor assembly (2 of 6)	118
Figure 1-162	Remove the RD sensor assembly (3 of 6)	118
Figure 1-163	Remove the RD sensor assembly (4 of 6)	119
Figure 1-164	Remove the RD sensor assembly (5 of 6)	119
Figure 1-165	Remove the RD sensor assembly (6 of 6)	120
Figure 1-166	Remove the power-supply fan (1 of 4)	121
Figure 1-167	Remove the power-supply fan (2 of 4)	122
Figure 1-168	Remove the power-supply fan (3 of 4)	122
Figure 1-169	Remove the power-supply fan (4 of 4)	123
Figure 1-170	Remove the registration assembly (1 of 8)	124
Figure 1-171	Remove the registration assembly (2 of 8)	125
Figure 1-172	Remove the registration assembly (3 of 8)	125
Figure 1-173	Remove the registration assembly (4 of 8)	126
Figure 1-174	Remove the registration assembly (5 of 8)	126
Figure 1-175	Remove the registration assembly (6 of 8)	127
Figure 1-176	Remove the registration assembly (7 of 8)	127
Figure 1-177	Remove the registration assembly (8 of 8)	128
Figure 1-178	Remove the high-voltage power supply lower (1 of 4)	129
Figure 1-179	Remove the high-voltage power supply lower (2 of 4)	130
Figure 1-180	Remove the high-voltage power supply lower (3 of 4)	130
Figure 1-181	Remove the high-voltage power supply lower (4 of 4)	131
Figure 1-182	Reinstall the high-voltage power supply lower	131
Figure 1-183	Remove the developing-disengagement motor (1 of 2)	132
Figure 1-184	Remove the developing-disengagement motor (2 of 2)	133
Figure 1-185	Remove the pickup motor	134
Figure 1-186	Remove the lifter-drive assembly (1 of 2)	135
Figure 1-187	Remove the lifter-drive assembly (2 of 2)	136
Figure 1-188	Remove the tray-pickup drive assembly (1 of 10)	137
Figure 1-189	Remove the tray-pickup drive assembly (2 of 10)	138
Figure 1-190	Remove the tray-pickup drive assembly (3 of 10)	138
Figure 1-191	Remove the tray-pickup drive assembly (4 of 10)	139
Figure 1-192	Remove the tray-pickup drive assembly (5 of 10)	139
Figure 1-193	Remove the tray-pickup drive assembly (6 of 10)	140
Figure 1-194	Remove the tray-pickup drive assembly (7 of 10)	140
Figure 1-195	Remove the tray-pickup drive assembly (8 of 10)	141
Figure 1-196	Remove the tray-pickup drive assembly (9 of 10)	141

Figure 1-197	Remove the tray-pickup drive assembly (10 of 10)	142
Figure 1-198	Reinstall the tray-pickup drive assembly (1 of 3)	142
Figure 1-199	Reinstall the tray-pickup drive assembly (2 of 3)	143
Figure 1-200	Reinstall the tray-pickup drive assembly (3 of 3)	143
Figure 1-201	Remove the tray-pickup assembly (1 of 3)	144
Figure 1-202	Remove the tray-pickup assembly (2 of 3)	145
Figure 1-203	Remove the tray-pickup assembly (3 of 3)	145
Figure 1-204	Remove the laser/scanner assembly (Y/M) (1 of 12)	146
Figure 1-205	Remove the laser/scanner assembly (Y/M) (2 of 12)	147
Figure 1-206	Remove the laser/scanner assembly (Y/M) (3 of 12)	147
Figure 1-207	Remove the laser/scanner assembly (Y/M) (4 of 12)	148
Figure 1-208	Remove the laser/scanner assembly (Y/M) (5 of 12)	148
Figure 1-209	Remove the laser/scanner assembly (Y/M) (6 of 12)	149
Figure 1-210	Remove the laser/scanner assembly (Y/M) (7 of 12)	149
Figure 1-211	Remove the laser/scanner assembly (Y/M) (8 of 12)	150
Figure 1-212	Remove the laser/scanner assembly (Y/M) (9 of 12)	150
Figure 1-213	Remove the laser/scanner assembly (Y/M) (10 of 12)	151
Figure 1-214	Remove the laser/scanner assembly (Y/M) (11 of 12)	151
Figure 1-215	Remove the laser/scanner assembly (Y/M) (12 of 12)	152
Figure 1-216	Remove the laser/scanner assembly (C/Bk) (1 of 7)	154
Figure 1-217	Remove the laser/scanner assembly (C/Bk) (2 of 7)	154
Figure 1-218	Remove the laser/scanner assembly (C/Bk) (3 of 7)	155
Figure 1-219	Remove the laser/scanner assembly (C/Bk) (4 of 7)	155
Figure 1-220	Remove the laser/scanner assembly (C/Bk) (5 of 7)	156
Figure 1-221	Remove the laser/scanner assembly (C/Bk) (6 of 7)	157
Figure 1-222	Remove the laser/scanner assembly (C/Bk) (7 of 7)	158
Figure 1-223	Reinstall the PGC actuators (1 of 5)	158
Figure 1-224	Reinstall the PGC actuators (2 of 5)	159
Figure 1-225	Reinstall the PGC actuators (3 of 5)	159
Figure 1-226	Reinstall the PGC actuators (4 of 5)	160
Figure 1-227	Reinstall the PGC actuators (5 of 5)	160
Figure 1-228	Remove the high-voltage power supply upper (1 of 5)	161
Figure 1-229	Remove the high-voltage power supply upper (2 of 5)	162
Figure 1-230	Remove the high-voltage power supply upper (3 of 5)	162
Figure 1-231	Remove the high-voltage power supply upper (4 of 5)	163
Figure 1-232	Remove the high-voltage power supply upper (5 of 5)	163
Figure 1-233	Reinstall the high-voltage power supply upper	164
Figure 1-234	Remove the drum motor 1	165
Figure 1-235	Remove the drum motor 2 or drum motor 3	166
Figure 1-236	Remove the fuser motor	167
Figure 1-237	Remove the main-drive assembly (1 of 7)	169

Figure 1-238	Remove the main-drive assembly (2 of 7)	169
Figure 1-239	Remove the main-drive assembly (3 of 7)	170
Figure 1-240	Remove the main-drive assembly (4 of 7)	170
Figure 1-241	Remove the main-drive assembly (5 of 7)	171
Figure 1-242	Remove the main-drive assembly (6 of 7)	171
Figure 1-243	Remove the main-drive assembly (7 of 7)	172
Figure 1-244	Reinstall the main-drive assembly (1 of 11)	173
Figure 1-245	Reinstall the main-drive assembly (2 of 11)	173
Figure 1-246	Reinstall the main-drive assembly (3 of 11)	174
Figure 1-247	Reinstall the main-drive assembly (4 of 11)	174
Figure 1-248	Reinstall the main-drive assembly (5 of 11)	175
Figure 1-249	Reinstall the main-drive assembly (6 of 11)	176
Figure 1-250	Reinstall the main-drive assembly (7 of 11)	176
Figure 1-251	Reinstall the main-drive assembly (8 of 11)	177
Figure 1-252	Reinstall the main-drive assembly (9 of 11)	177
Figure 1-253	Reinstall the main-drive assembly (10 of 11)	178
Figure 1-254	Reinstall the main-drive assembly (11 of 11)	178
Figure 1-255	Remove the fuser-drive assembly (1 of 6)	180
Figure 1-256	Remove the fuser-drive assembly (2 of 6)	180
Figure 1-257	Remove the fuser-drive assembly (3 of 6)	181
Figure 1-258	Remove the fuser-drive assembly (4 of 6)	181
Figure 1-259	Remove the fuser-drive assembly (5 of 6)	182
Figure 1-260	Remove the fuser-drive assembly (6 of 6)	182
Figure 1-261	Reinstall the fuser-drive assembly	183
Figure 1-262	Remove the delivery assembly (1 of 5)	185
Figure 1-263	Remove the delivery assembly (2 of 5)	185
Figure 1-264	Remove the delivery assembly (3 of 5)	186
Figure 1-265	Remove the delivery assembly (4 of 5)	186
Figure 1-266	Remove the delivery assembly (5 of 5)	187
Figure 1-267	Reinstall the delivery assembly (1 of 2)	188
Figure 1-268	Reinstall the delivery assembly (2 of 2)	188
Figure 1-269	Remove the duplex-drive assembly (1 of 2)	190
Figure 1-270	Remove the duplex-drive assembly (2 of 2)	190
Figure 1-271	Remove the drawer connector; optional paper feeder (1 of 2)	191
Figure 1-272	Remove the drawer connector; optional paper feeder (2 of 2)	192
Figure 2-1	Base product (no optional trays or accessories)	204
Figure 2-2	Base product (optional trays or accessories)	205
Figure 2-3	External covers, panels, and doors	206
Figure 2-4	Right-door assembly	208
Figure 2-5	Internal assemblies (1 of 6)	210
Figure 2-6	Internal assemblies (2 of 6)	212

Figure 2-7	Internal assemblies (3 of 6)	214
Figure 2-8	Internal assemblies (4 of 6)	216
Figure 2-9	Internal assemblies (5 of 6)	218
Figure 2-10	Internal assemblies (6 of 6)	220
Figure 2-11	1 x 500-sheet paper feeder	222
Figure 2-12	Paper feeder covers	224
Figure 2-13	Paper feeder main body	226
Figure 2-14	Tray	228
Figure 2-15	Paper feeder PCA	230

1 Removal and replacement

 **NOTE:** Your product might not appear exactly as the one shown in the photos in this chapter. Although some photos do not show the ADF/scanner unit, the procedures in this chapter are appropriate for your product.

- [Introduction](#)
- [Removal and replacement strategy](#)
- [Service approach](#)
- [Removal and replacement procedures](#)

Introduction

This chapter describes the removal and replacement of field-replaceable units (FRUs) only.

Replacing FRUs is generally the reverse of removal. Occasionally, notes and tips are included to provide directions for difficult or critical replacement procedures.

HP does *not* support repairing individual subassemblies or troubleshooting to the component level.

Note the length, diameter, color, type, and location of each screw. Be sure to return each screw to its original location during reassembly.

Incorrectly routed or loose wire harnesses can interfere with other internal components and can become damaged or broken. Frayed or pinched harness wires can be difficult to find. When replacing wire harnesses, always use the provided wire loops, lance points, or wire-harness guides and retainers.

Removal and replacement strategy

General cautions during removal and replacement

This chapter describes the removal and replacement of field-replaceable units (FRUs) only.

Replacing FRUs is generally the reverse of removal. Occasionally, notes and tips are included to provide directions for difficult or critical replacement procedures.

HP does *not* support repairing individual subassemblies or troubleshooting to the component level.

 **WARNING!** Turn the product off, wait 5 seconds, and then remove the power cable before attempting to service the product. If this warning is not followed, severe injury can result, in addition to damage to the product. The power must be on for certain functional checks during troubleshooting. However, disconnect the power supply during parts removal.

Never operate or service the product with the protective cover removed from the laser scanner assembly. The reflected beam, although invisible, can damage your eyes.

The sheet-metal parts can have sharp edges. Be careful when handling sheet-metal parts.

 **CAUTION:** Do not bend or fold the flat flexible cables (FFCs) during removal or installation. Also, do not straighten prefolds in the FFCs. You *must* fully seat all FFCs in their connectors. Failure to fully seat an FFC into a connector can cause a short circuit in a Printed Circuit Assembly (PCA).



Incorrectly routed or loose wire harnesses can interfere with other internal components and can become damaged or broken. Frayed or pinched harness wires can be difficult to find. When replacing wire harnesses, always use the provided wire loops, lance points, or wire-harness guides and retainers.

 **NOTE:** To install a self-tapping screw, first turn it counterclockwise to align it with the thread pattern, and then carefully turn it clockwise to tighten. Do not overtighten. If a self-tapping screw-hole becomes stripped, repair the screw-hole or replace the affected assembly.

Note the length, diameter, color, type, and location of each screw. Be sure to return each screw to its original location during reassembly.

 **TIP:** For clarity, some photos in this chapter might show components removed that would not be removed to service the product. If necessary, remove the components listed at the beginning of a procedure before proceeding to service the product.

Electrostatic discharge

 **CAUTION:**  Some parts are sensitive to electrostatic discharge (ESD). Look for the ESD reminder when removing product parts. Always perform service work at an ESD-protected workstation or mat, or use an ESD strap. If an ESD workstation, mat, or strap is not available, ground yourself by touching the sheet-metal chassis *before* touching an ESD-sensitive part.

Protect the ESD-sensitive parts by placing them in ESD pouches when they are out of the product.

Required tools

- #1 Phillips screwdriver with a magnetic tip and a 152-mm (6-inch) shaft length
- #2 Phillips screwdriver with a magnetic tip and a 152-mm (6-inch) shaft length
- Small flat blade screwdriver
- Needle-nose pliers
- ESD mat or ESD strap (if one is available)
- Penlight (optional)

 **CAUTION:** Always use a Phillips screwdriver (callout 1). Do not use a Pozidriv® screwdriver (callout 2) or any motorized screwdriver. These can damage screws or screw threads.

Figure 1-1 Phillips and Pozidriv screwdriver comparison



Types of screws



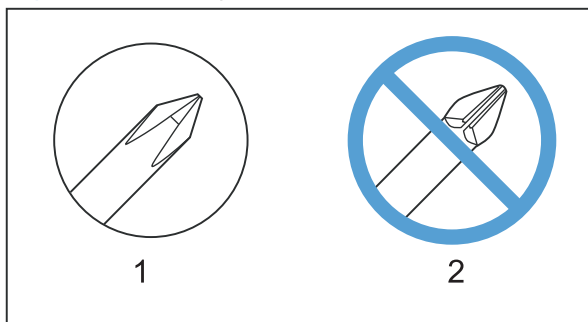

 **NOTE:** The illustrations in this section are for reference only. The screws in your product might look slightly different.

Illustration	Description	Size	Part number	Use
	Screw with washer	M3X6	XB2-7300-000CN	Used to secure metal components to metal components (for example, a ground wire to the frame)
	Screw, tapping	M3X6	XA9-1503-000CN	
	Screw	D-M3X6	XA9-1671-000CN	
	Screw	P-M3X8	XB4-5300-807CN	
	Screw, tapping, truss head	M4X10	XB4-7401-005CN	Used to secure anything to plastic

6 mm 8 mm 10 mm M 3 M 4

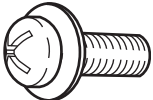
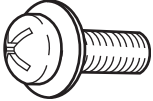
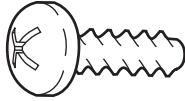

Service approach

Product repair normally begins by using the product internal diagnostics and the following two-step process:

1. Isolate the problem to the major system (for example, the network or server, or the product).
2. Troubleshoot the problem by using the procedures in the solve problems chapter.

After you find a faulty part, the product can usually be repaired at the assembly level by replacing field-replaceable units (FRUs). Some mechanical assemblies might need to be repaired at the subassembly level.

Before performing service

- Remove all media from the product.
- Turn off the power using the power switch.
- Unplug the power cable and interface cable or cables.
- Place the product on an ESD workstation or mat, or use an ESD strap (if one is available). If an ESD workstation, mat, or strap is not available, ground yourself by touching the sheet-metal chassis *before* touching an ESD-sensitive part.
- Remove the toner cartridges. See [Toner cartridges on page 9](#).
- Remove the tray or trays. See [Tray 2 and 3 on page 14](#).

After performing service

- Plug in the power cable.
- Reinstall the toner cartridges.
- Reinstall the tray or trays.
- If the optional paper feeder was installed, place the product on the feeder.



NOTE: Your product might not appear exactly as the one shown in the photos in this chapter. Although some photos do not show the ADF/scanner unit, the procedures in this chapter are appropriate for this product.

Post-service test

Perform the following test to verify that the repair or replacement was successful.



NOTE: Your product might not appear exactly as the one shown in the photos in this chapter. Although some photos do not show the ADF/scanner unit, the procedures in this chapter are appropriate for this product.

Print-quality test

1. Verify that you have completed the necessary reassembly steps.
2. Make sure that the trays contain clean, unmarked paper.
3. Attach the power cord and interface cable or interface cables, and then turn on the product.
4. Verify that the expected startup sounds occur.
5. Print a configuration page, and then verify that the expected printing sounds occur.
6. Print a demo page, and then verify that the print quality is as expected.
7. Send a print job from the host computer, and then verify that the output meets expectations.
8. If necessary, restore any customer-specified settings.
9. Clean the outside of the product with a damp cloth.

Copy-quality test

1. Verify that you have completed the necessary reassembly steps.
2. Ensure that the input tray contains clean, unmarked paper.
3. Attach the power cord, and then turn on the product.
4. Verify that the expected start-up sounds occur.
5. Print a configuration page, and then verify that the expected printing sounds occur.
6. Place the configuration page in the Automatic Document Feeder (ADF).
7. Print a copy job, and then verify the results.
8. Place the configuration page on the scanner glass.
9. Print a copy job, and then verify the results.
10. Clean the outside of the product with a damp cloth.

DC controller PCA

Figure 1-2 DC controller PCA

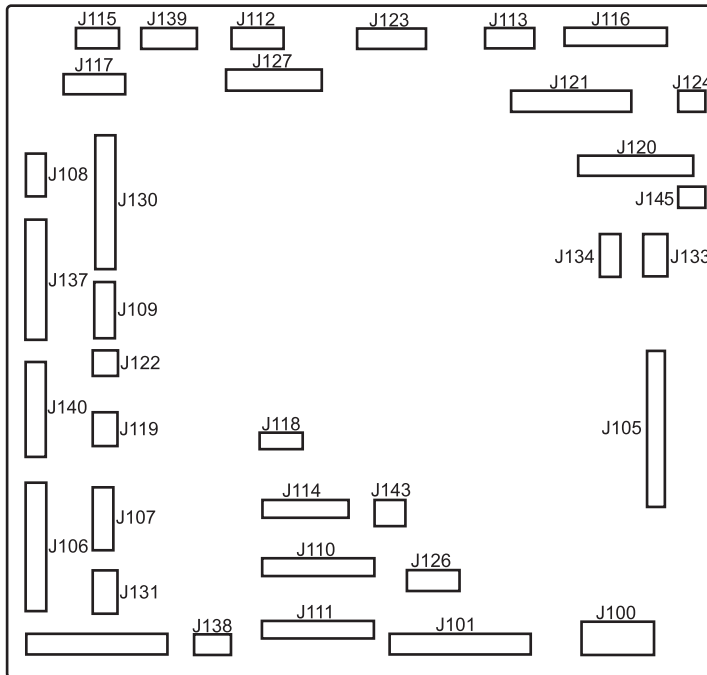

J100: 24 v from low-voltage power supply (LVPS) and interlock	J114: HVPS lower	J126: memory tag connector
J101: LVPS	J115: fuser sensors	J127: pre-exposure LEDs (rear), SR17, SL1
J105: interconnect board (ICB)	J116: HVPS upper	J130: registration density (RD) sensors (front and rear)
J106: 500-sheet feeder, developing home position, laser motors	J117: fuser motor	J131: pickup motor
J107: duplex sensor, tray 1 solenoid, paper present sensor	J118: 5 v interlock	J133: not used
J108: environmental sensor	J119: LVPS fan	J134: not used
J109: duplex clutch, overhead transparency (OHT) in, top-of-page sensor	J120: drum motor 1 and drum motor 2	J137: toner collection unit (TCU) full, TCU motor, toner level detection
J110: YM laser	J121: drum motor 3, drum position 1,2,3	J138: 24 v to HVPS lower
J111: CK laser	J122: OHT out	J139: fuser sensors
J112: pre-exposure LEDs (front)	J123: pressure release, bin full, fuser delivery	J140: lift motor, tray present, stack surface
J113: 24 v to high-voltage power supply (HVPS) upper	J124: 24 v to scanner	J143: 24 v present from LVPS
J145: not used		

Parts removal order

Some procedures in this chapter include a list of assemblies that must be removed prior to beginning a specific removal process. Remove the listed assemblies in the order that they appear in the list.

Removal and replacement procedures

Customer self repair (CSR) components

 **NOTE:** Your product might not appear exactly as the one shown in the photos in this chapter. Although some photos do not show the ADF/scanner unit, the procedures in this chapter are appropriate for this product.

Toner cartridges

 **CAUTION:** If toner gets on your clothing, wipe it off with a dry cloth and wash clothing in cold water. *Hot water sets toner into fabric.*

1. Open the front door. Make sure that the door is completely open.

Figure 1-3 Remove the toner cartridge (1 of 2)



2. Grasp the toner-cartridge handle and pull it out of the product to remove it.

CAUTION: Do not touch the green roller. Doing so can damage the cartridge. Do not expose the cartridge to strong light. Cover the cartridge with a sheet of paper to protect it from light.

Reinstallation tip Align the toner cartridge with its slot and insert the toner cartridge until it clicks into place.

Figure 1-4 Remove the toner cartridge (2 of 2)

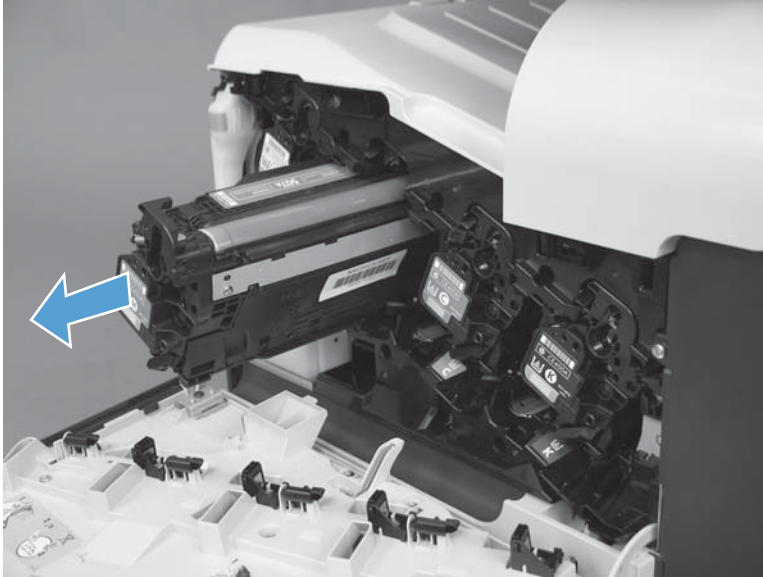

Duplex-reverse guide

1. Grasp the duplex-reverse guide and pull it away from the product to release it.

Figure 1-5 Remove the duplex-reverse guide (1 of 2)

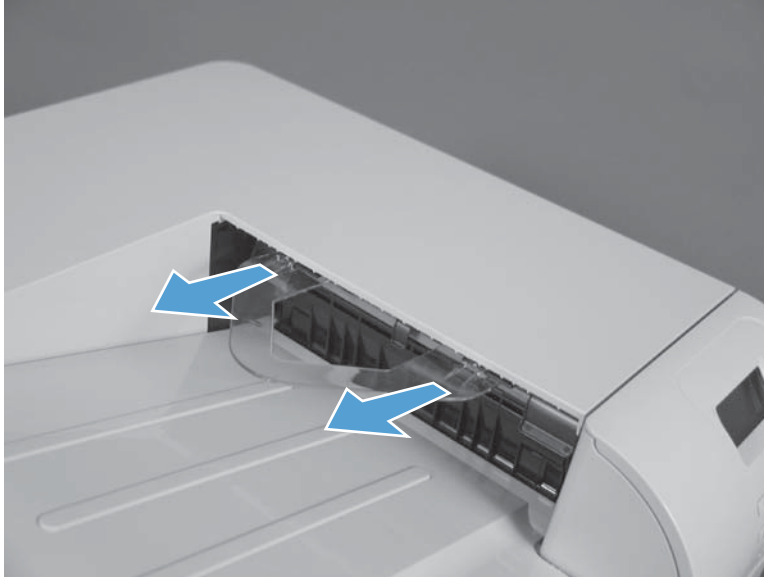

2. Remove the guide.

Figure 1-6 Remove the duplex-reverse guide (2 of 2)



Toner-collection unit

 **NOTE:** The toner-collection unit is designed for a single use. Do not try to empty the toner-collection unit and reuse it. Doing so could cause toner to spill inside the product and result in reduced print quality. For recycling information, see the product user guide.

1. Open the front door. Make sure that the door is completely open.

Figure 1-7 Remove the toner-collection unit (1 of 4)



2. Grasp the blue label at the top of the toner-collection unit and remove it from the product.

 **Reinstallation tip** Insert the bottom of the replacement unit into the product first and then push the top of the unit until it clicks into place. If the toner-collection unit is installed incorrectly, the front door will not close completely.

Figure 1-8 Remove the toner-collection unit (2 of 4)



3. To prevent toner spills, place the blue cap (callout 1) over the blue opening at the top of the unit (callout 2).

Figure 1-9 Remove the toner-collection unit (3 of 4)

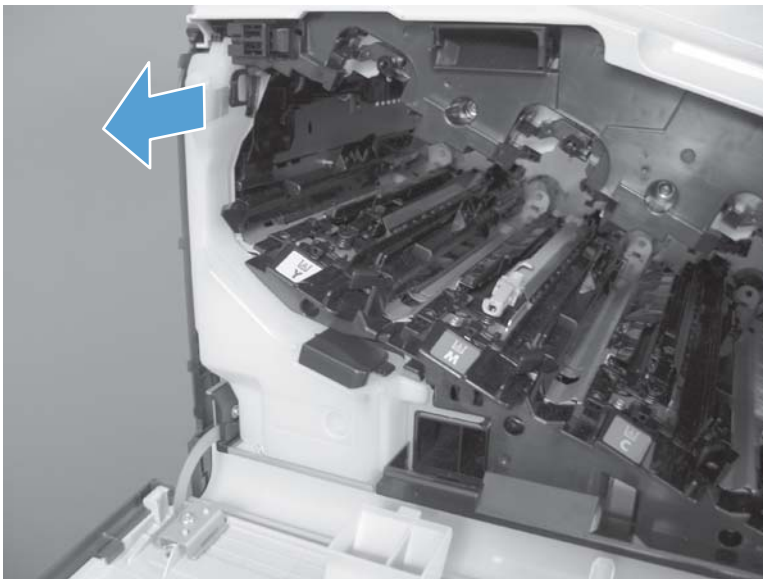

Figure 1-10 Remove the toner-collection unit (4 of 4)



Tray 2 and 3

 **NOTE:** Use this procedure to remove the Tray 2 or optional Tray 3.

1. Pull the tray straight out of the product until it stops.

Figure 1-11 Remove Tray 2 and 3 (1 of 2)

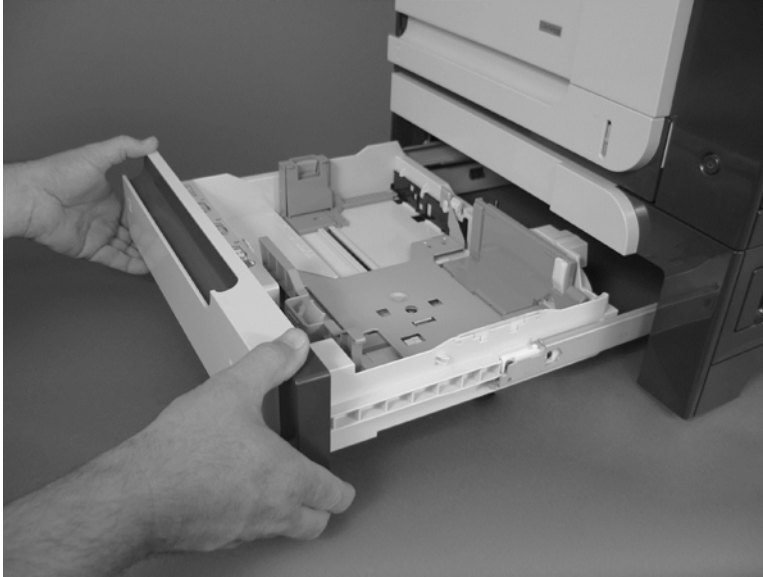

2. Carefully lift up on the tray to release it, and then remove the tray.

Figure 1-12 Remove Tray 2 and 3 (2 of 2)

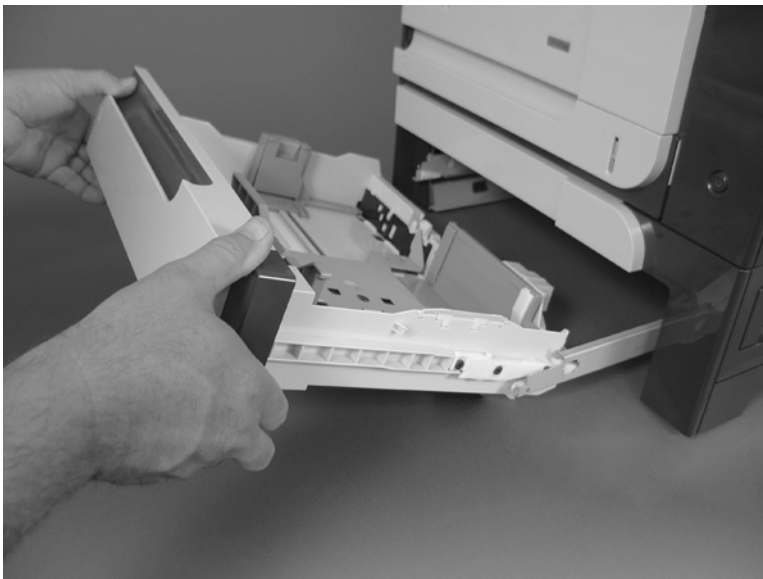

Pickup roller and separation pad (Tray 1)

⚠ CAUTION: Skin oils on the roller or pad can cause paper pickup problems. Wash your hands before handling the assembly.

1. Open Tray 1, release two tabs (callout 1), and then rotate the roller cover away from the product to remove it.

💡 TIP: Push down along the top edge of the cover to easily release the tabs.

Figure 1-13 Remove the pickup roller and separation pad (Tray 1) (1 of 3)

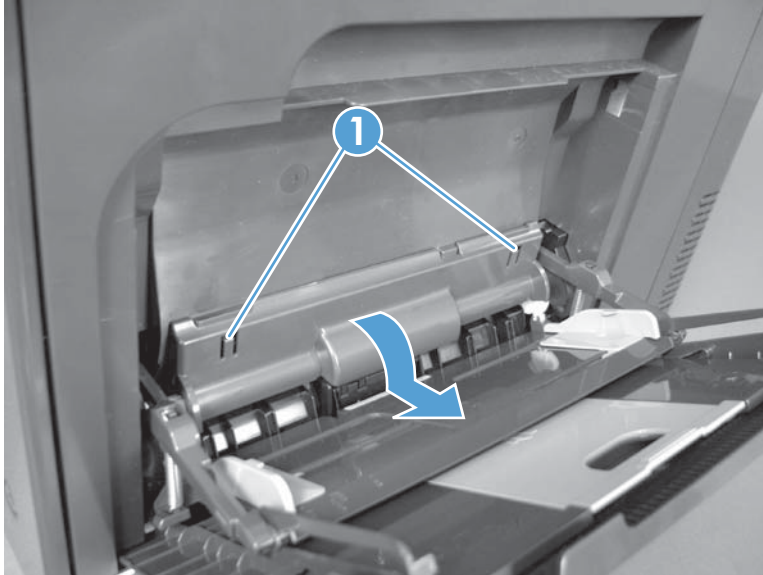

2. Release two tabs and rotate the roller body away from the product to remove it.

Figure 1-14 Remove the pickup roller and separation pad (Tray 1) (2 of 3)

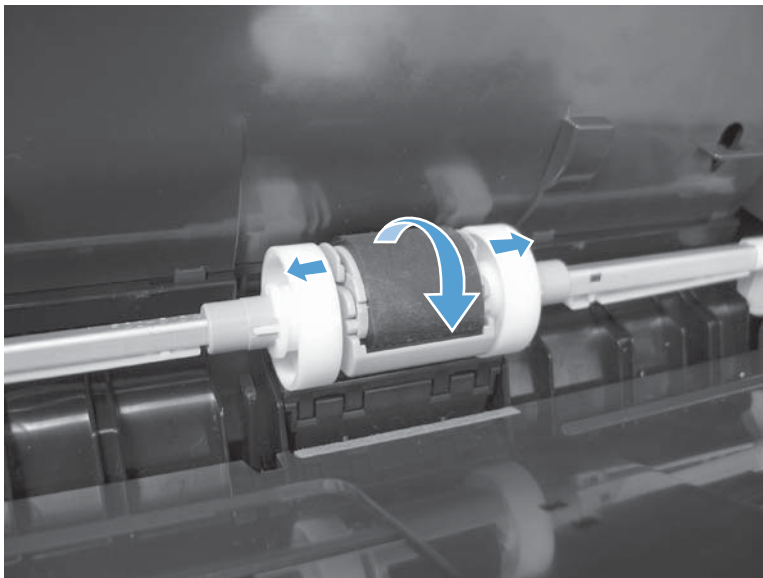

3. Use a small flat blade screwdriver to release two tabs, and then remove the separation pad.

 **TIP:** You might need to slightly depress the spring-loaded separation pad pedestal to remove the separation pad.

Figure 1-15 Remove the pickup roller and separation pad (Tray 1) (3 of 3)



Pickup roller (Tray 2)

⚠ CAUTION: Skin oils on the roller can cause paper pickup problems. Wash your hands before handling the assembly.

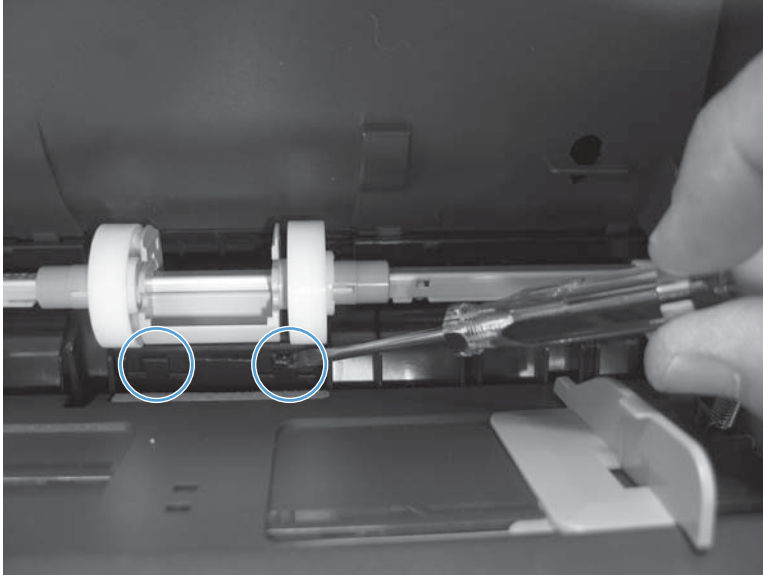
1. Look up into the Tray 2 cavity (where the tray would be installed), and pull down to release the blue roller-locking lever.

💡 Reinstallation tip When the roller is reinstalled, rotate the roller shaft several times to make sure that the shaft correctly engages the drive mechanism. You should hear a click when the shaft engages the drive mechanism.

Figure 1-16 Remove the pickup roller (Tray 2) (1 of 4)

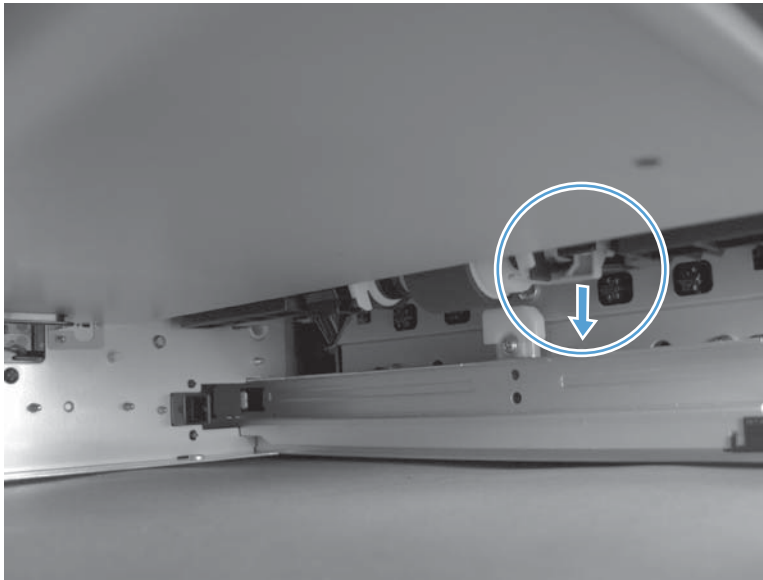

2. Pull the roller toward the front of the product to release the rear of the roller shaft.

Figure 1-17 Remove the pickup roller (Tray 2) (2 of 4)

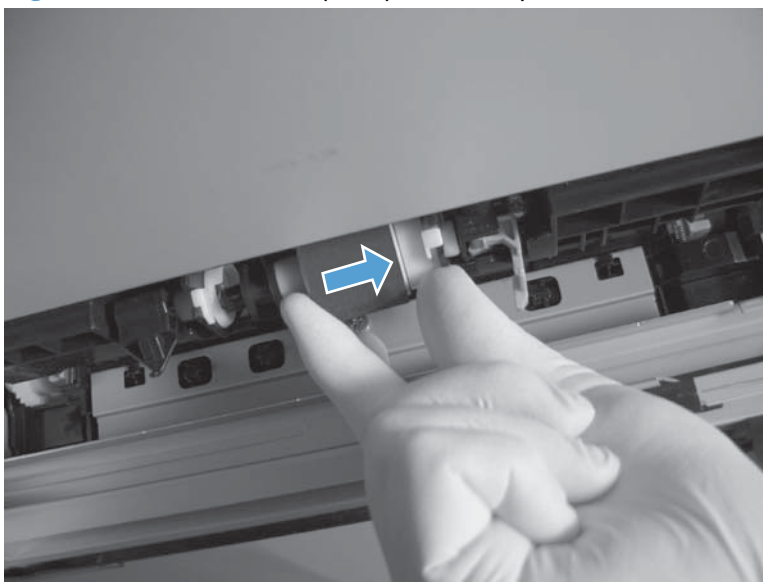

3. Rotate the roller shaft down and away from the product, and then slide the roller toward the rear of the product to release the front of the roller shaft.

Figure 1-18 Remove the pickup roller (Tray 2) (3 of 4)



4. Remove the pickup roller.

 **Reinstallation tip** Make sure that the roller is orientated correctly when it is reinstalled (the large white collar should be positioned toward the front of the product).

Figure 1-19 Remove the pickup roller (Tray 2) (4 of 4)



Pickup and feed rollers (Tray 3)

⚠ CAUTION: Skin oils on the roller can cause paper pickup problems. Wash your hands before handling the assembly.

1. Locate the Tray 3 pickup and feed rollers.

💡 TIP: The feeder is shown front side up in this procedure for clarity. You do not have to separate the product from the feeder to remove these rollers. Remove the tray, and then reach up into the cavity to remove the rollers.

Figure 1-20 Remove the pickup and feed rollers (Tray 3) (1 of 2)

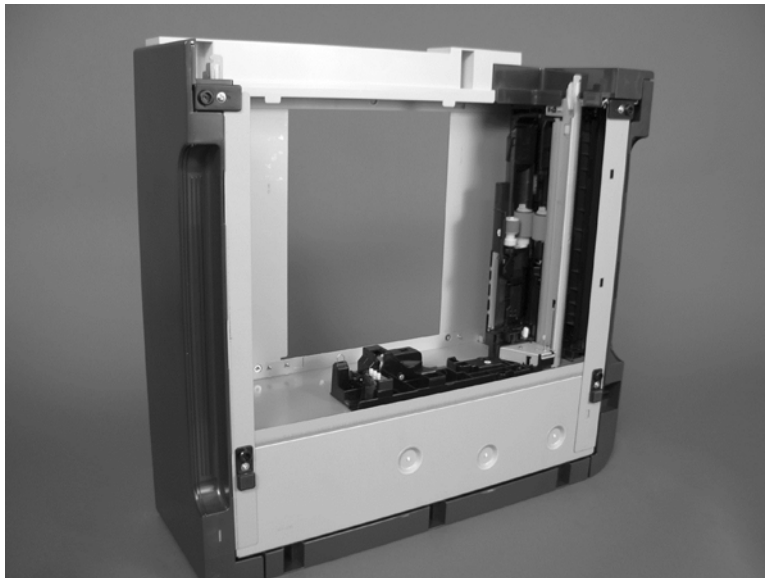

2. Release three tabs (callout 1), and then remove the rollers.

 **Reinstallation tip** When you reinstall the rollers, make sure that the rollers snap into place.

Figure 1-21 Remove the pickup and feed rollers (Tray 3) (2 of 2)



Separation roller (Tray 2)

⚠ CAUTION: Skin oils on the roller can cause paper pickup problems. Wash your hands before handling the assembly.

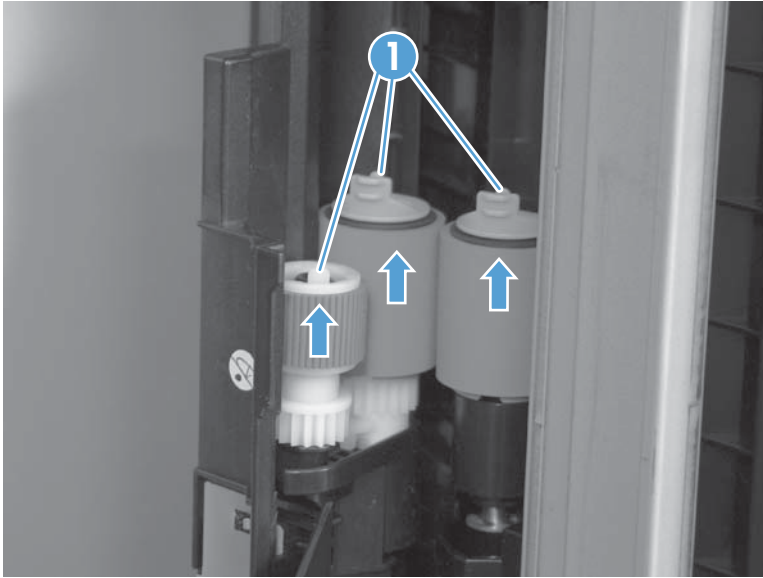
📝 NOTE: Remove the Tray 2 if not already removed for service. See [Tray 2 and 3 on page 14](#).

Remove two screws (callout 1), and then remove the separation roller assembly (callout 2).

Figure 1-22 Remove the separation roller (Tray 2)

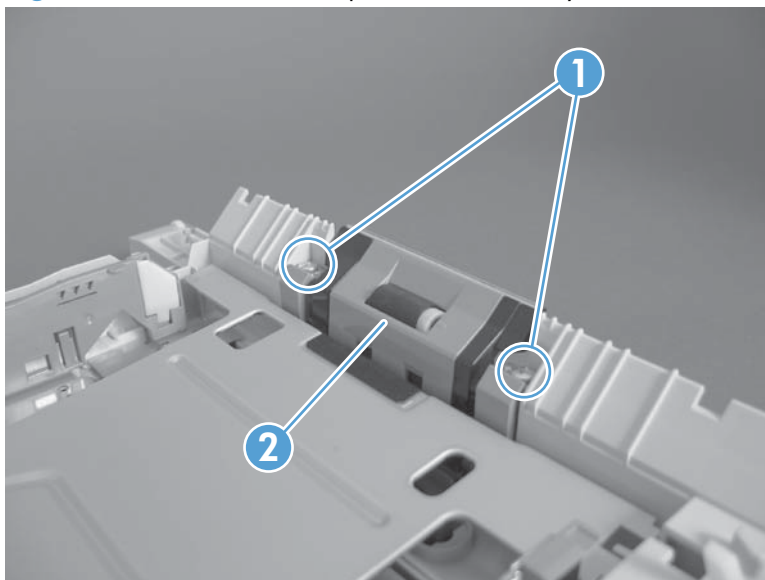

⚠ CAUTION: To install a self-tapping screw, first turn it counterclockwise to align it with the thread pattern, and then carefully turn it clockwise to tighten. Do not overtighten. If a self-tapping screw-hole becomes stripped, repair the screw-hole or replace the affected assembly.

Secondary transfer roller

CAUTION: Do not touch the spongy roller surface unless you are replacing the roller. Skin oils on the roller can cause image quality problems.

1. Open the right-door assembly.

Figure 1-23 Remove the transfer roller (1 of 3)

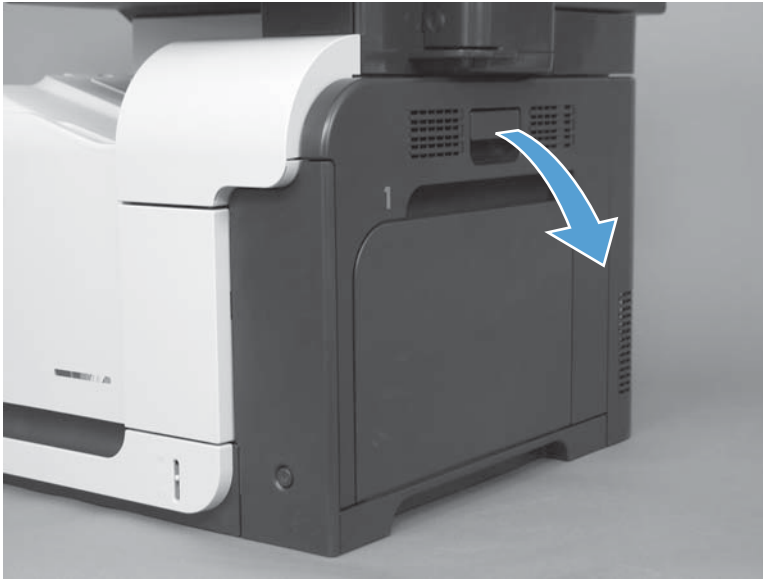

2. Use the blue lever (callout 1) to lower the secondary transfer assembly.

Figure 1-24 Remove the transfer roller (2 of 3)

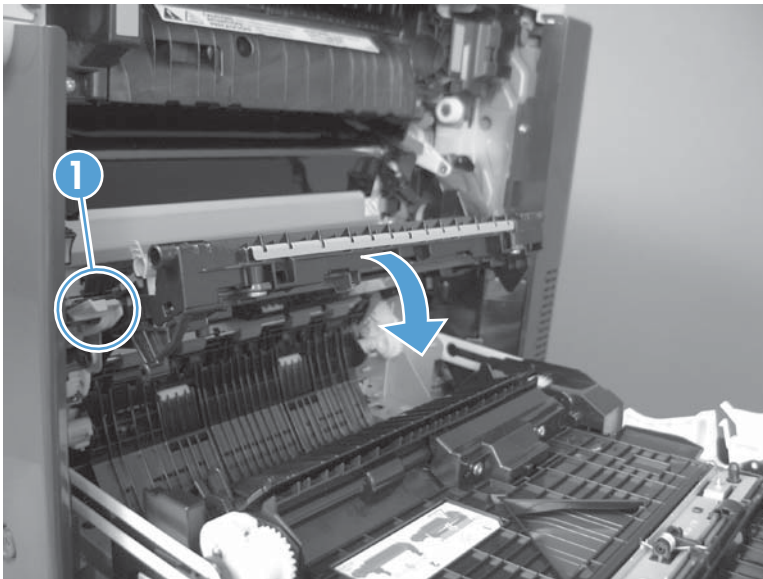

3. Grasp the roller shaft collars, and lift the transfer roller off of the product.

Figure 1-25 Remove the transfer roller (3 of 3)

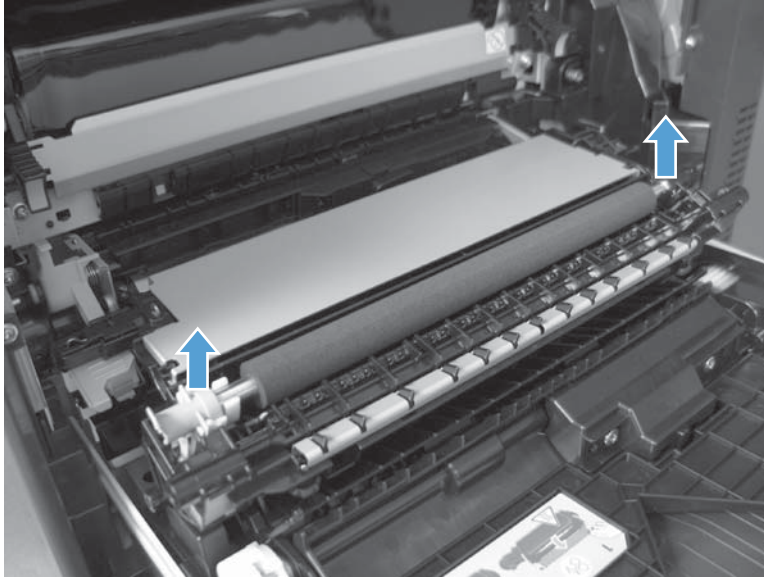

Reinstall the transfer roller

When you reinstall the transfer roller, make sure that the pins on the shaft collars (callout 1) align with the holes in the mounting assembly.

Figure 1-26 Reinstall the transfer roller

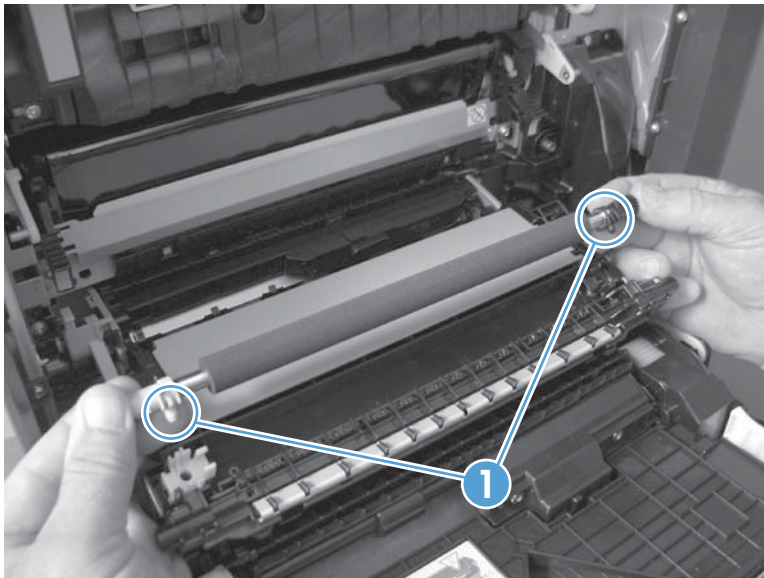

Intermediate transfer belt (ITB)

CAUTION: Do not touch the black-plastic belt. Skin oils and fingerprints on the belt can cause print-quality problems. Always place the ITB on a flat surface in a safe and protected location.

1. Open the right-door assembly.

Figure 1-27 Remove the intermediate transfer belt (1 of 4)

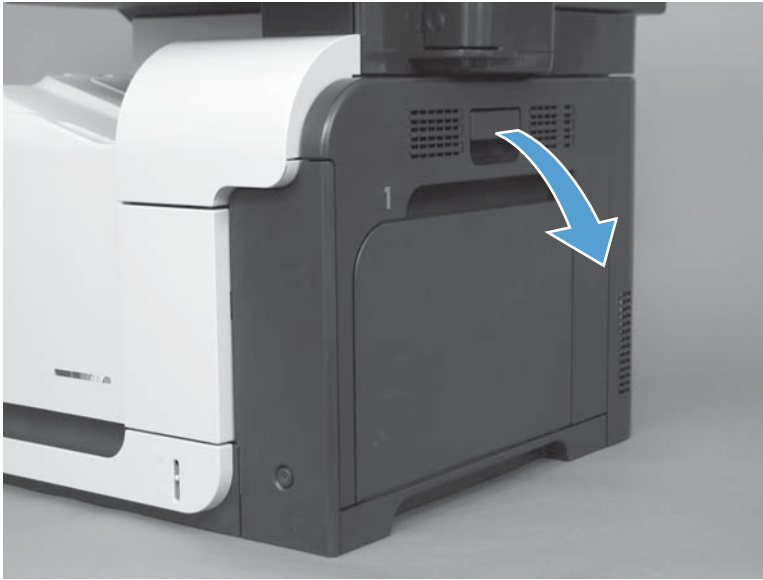

2. Use the blue lever (callout 1) to lower the secondary transfer assembly.

Figure 1-28 Remove the intermediate transfer belt (2 of 4)

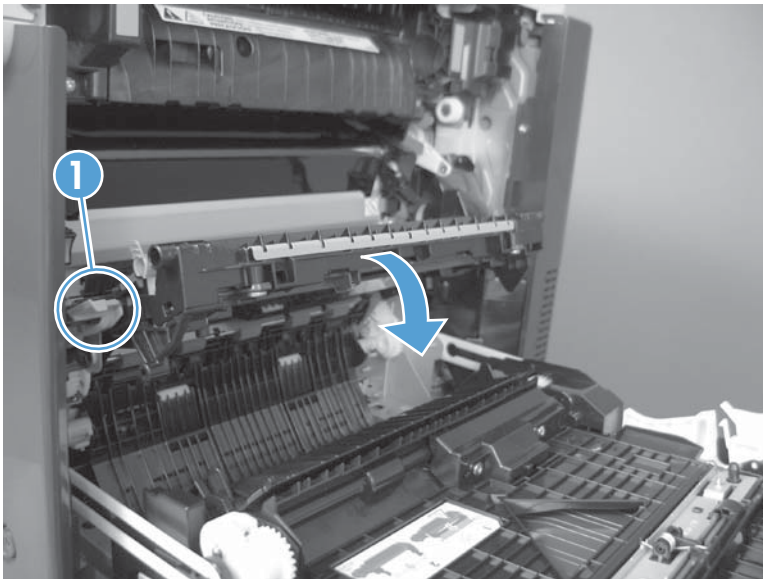

3. Grasp the small handles on the ITB and then pull the ITB out of the product until two large handles expand along the left and right sides of the ITB.

Figure 1-29 Remove the intermediate transfer belt (3 of 4)

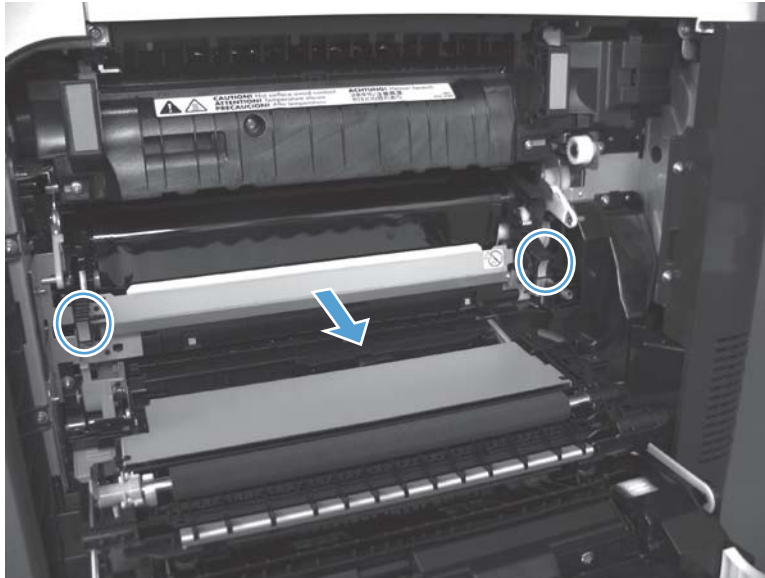

4. Grasp the large handles on the ITB and then pull the ITB straight out of the product to remove it.

⚠ CAUTION: The ITB is a sensitive component. Be careful when handling the ITB so that it is not damaged. Always place the ITB in a safe and protected location.

Figure 1-30 Remove the intermediate transfer belt (4 of 4)

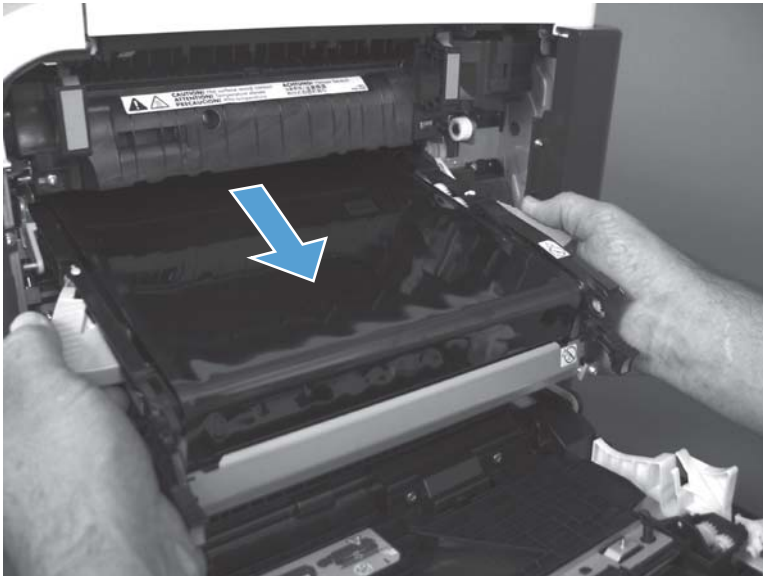

💡 Reinstallation tip If you are installing a replacement ITB, make sure that you remove all of the packing tape (callout 1) and the protective cover sheet (callout 2).

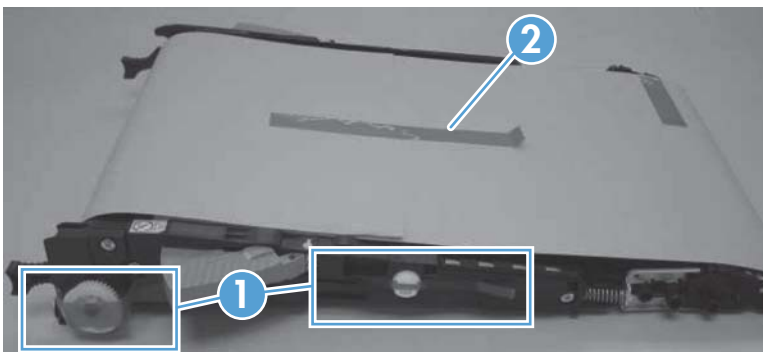

Front-door assembly

1. Open the front door.

Figure 1-31 Remove the front-door assembly (1 of 2)



2. Remove two screws (callout 1), and then remove the front-door assembly.

 **NOTE:** A small sheet-metal bracket on the left side of the door is not captive. Do not lose the bracket when you remove the screw.

Figure 1-32 Remove the front-door assembly (2 of 2)



3. If you are installing a replacement front-door assembly, install the HP nametag and the appropriate product model number tag on the assembly.

Document feeder pickup rollers

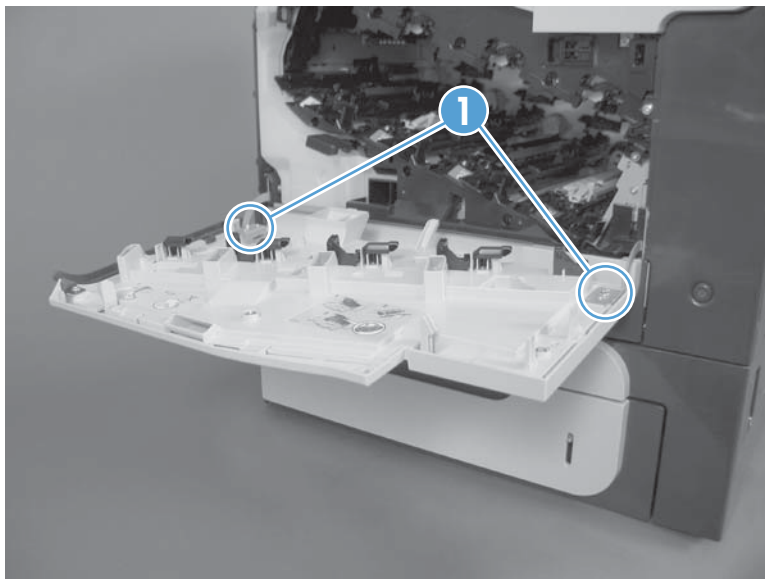
CAUTION: Skin oils deposited on the roller might cause print-quality problems. Wash your hands before handling the assembly.

1. Open the jam-access cover.

Figure 1-33 Remove the document feeder pickup rollers (1 of 5)

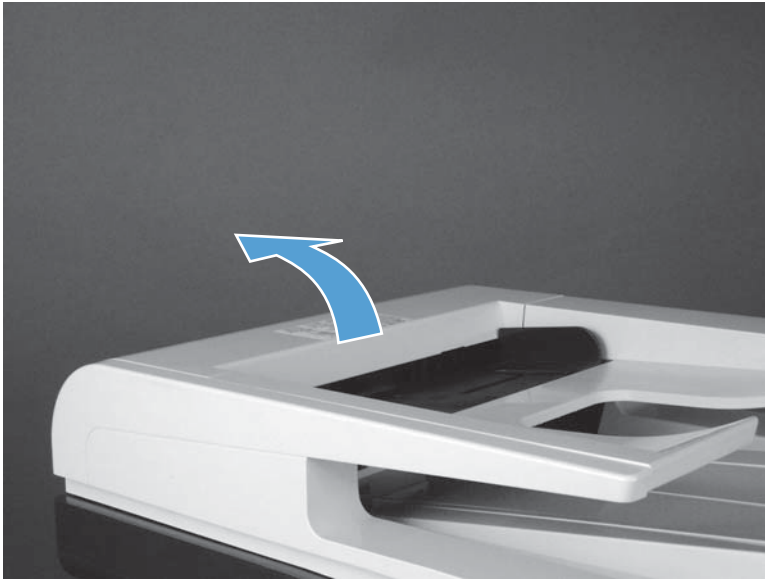

2. Release one tab (callout 1).

Figure 1-34 Remove the document feeder pickup rollers (2 of 5)

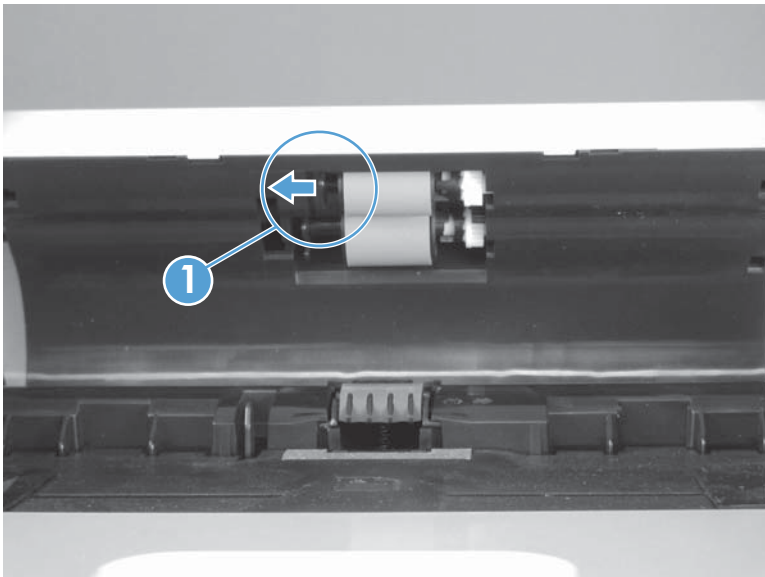

3. Rotate the shaft end of the roller assembly away from the document feeder (callout 1), and then slide the gear end of the roller out of the document feeder (callout 2) to remove the upper-roller assembly.

Figure 1-35 Remove the document feeder pickup rollers (3 of 5)

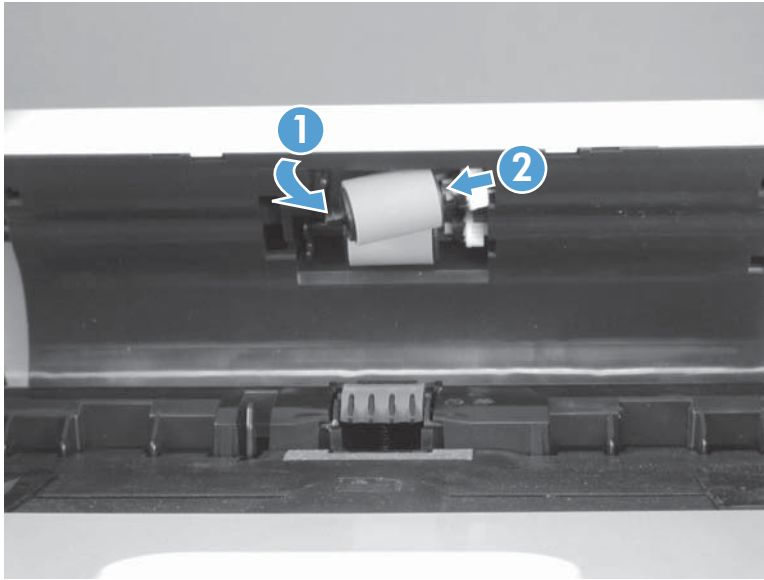

4. Release one tab (callout 1).

Figure 1-36 Remove the document feeder pickup rollers (4 of 5)

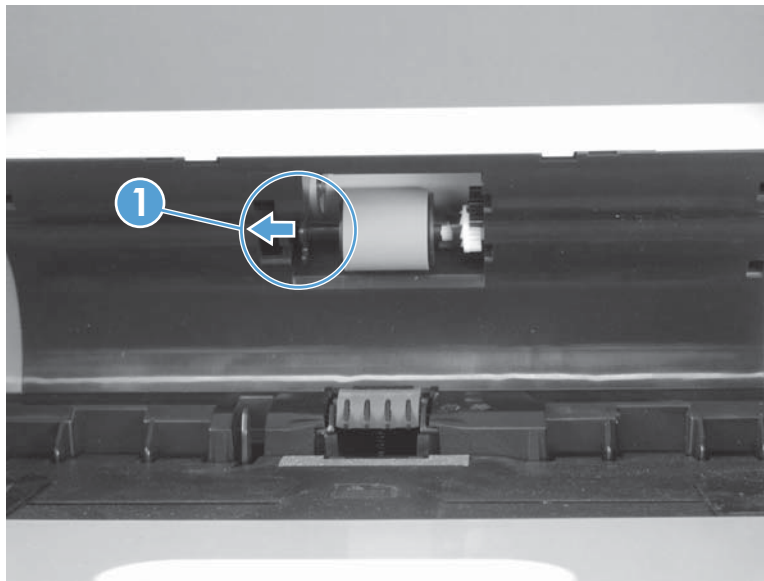

5. Rotate the shaft end of the roller assembly away from the document feeder (callout 1), and then slide the gear end of the roller out of the document feeder (callout 2) to remove the lower-roller assembly.

Figure 1-37 Remove the document feeder pickup rollers (5 of 5)

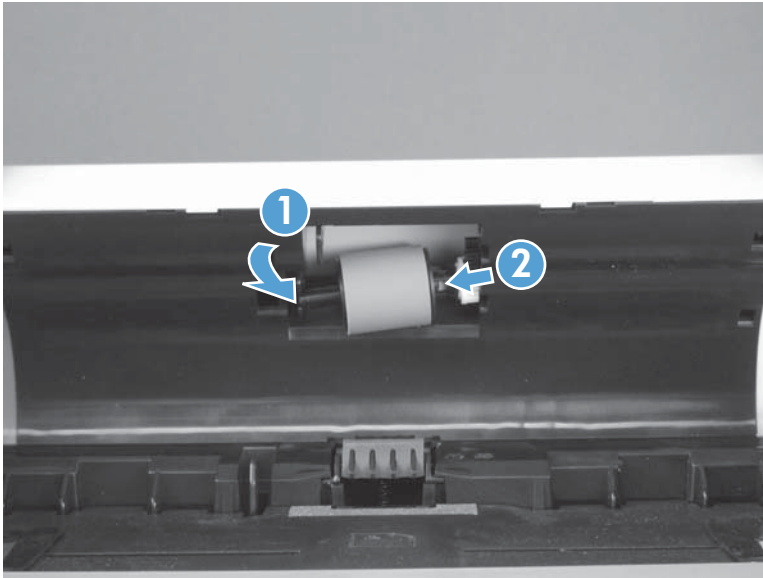

 **TIP:** The roller assembly is keyed. When reinstalling the roller assembly, position the hex-shaped fitting on the shaft toward the rear of the product.

Document feeder separation pad

⚠ CAUTION: Skin oils deposited on the roller might cause print-quality problems. Wash your hands before handling the assembly.

1. Open the jam-access cover.

Figure 1-38 Remove the document feeder separation pad (1 of 2)



2. Locate the separation pad at the end of the document feeder input tray, press down on the pad, and then slide the pad toward the input tray to remove it from the assembly.

Figure 1-39 Remove the document feeder separation pad (2 of 2)

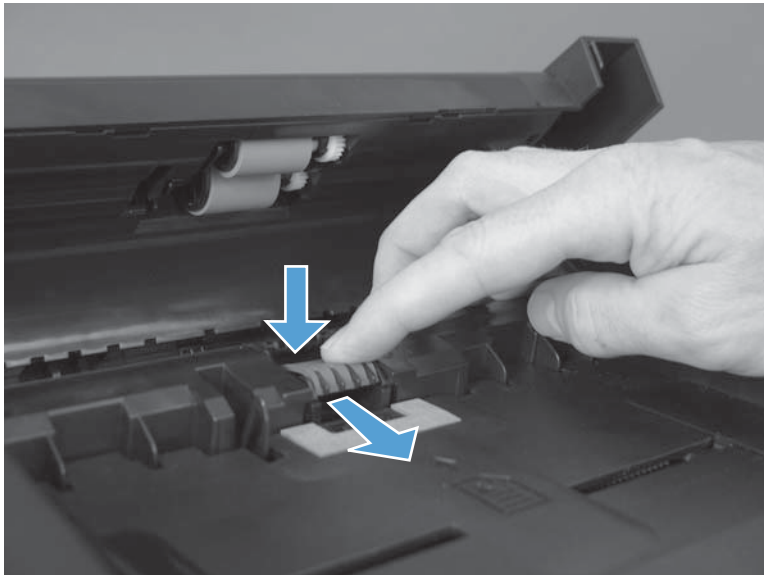

Control panel

Before proceeding, remove the following components:

- Right-rear cover. See [Right-rear cover on page 48](#).
- Left cover. See [Left cover on page 50](#).
- Rear-upper cover. See [Rear-upper cover on page 53](#).
- Left-upper cover. See [Left-upper cover on page 54](#).
- Right-upper rear cover. See [Right-upper rear cover on page 55](#).
- Rear cover. See [Rear cover on page 56](#).
- Document feeder. See [Document feeder on page 73](#).
- Image scanner. See [Image scanner on page 77](#).
- Interconnect board (ICB). See [Interconnect board \(ICB\) on page 88](#).

 **TIP:** Removing the ICB makes it easier to connect the control panel FFC when the control panel is reinstalled.

Remove the control panel

1. Disconnect one one FFC (callout 1).

Figure 1-40 Remove the control panel (1 of 6)

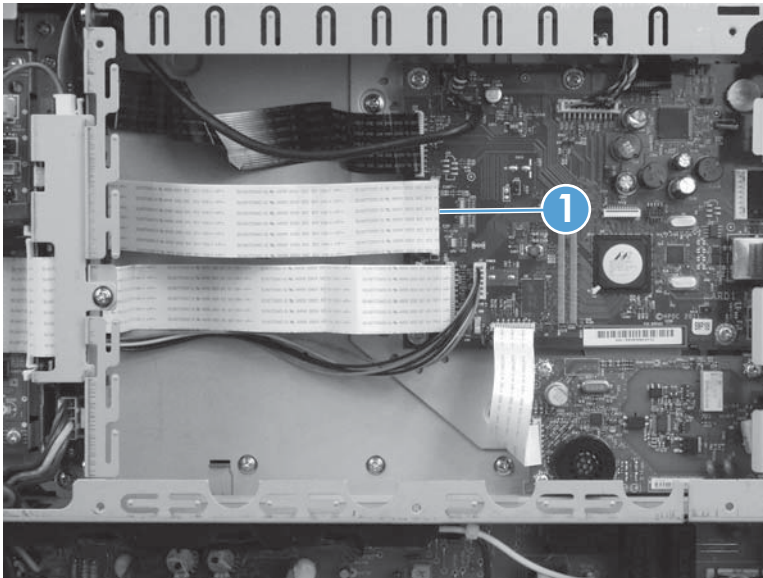

2. Feed the cable through the hole in the chassis (callout 1).

 **Reinstallation tip** The FFC might be fastened to the chassis in several places with two-sided adhesive tape. Make sure that you refasten the FFC to the chassis when the control panel is reinstalled.

Figure 1-41 Remove the control panel (2 of 6)



3. Remove one screw (callout 1), and then remove the right-upper front cover (callout 2).

Figure 1-42 Remove the control panel (3 of 6)

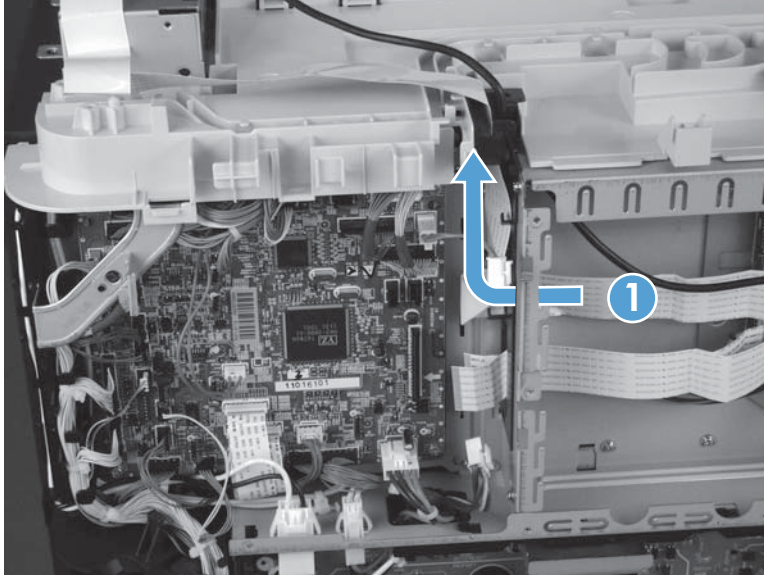
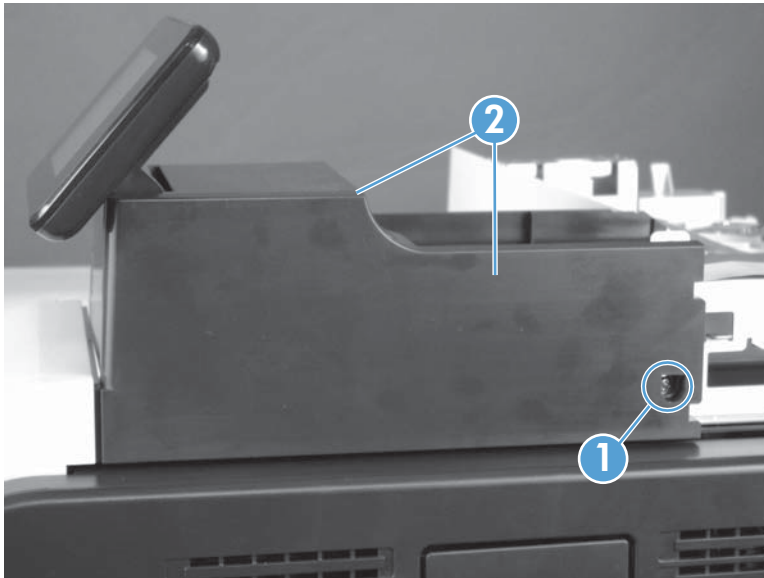

4. Remove one screw.

Figure 1-43 Remove the control panel (4 of 6)

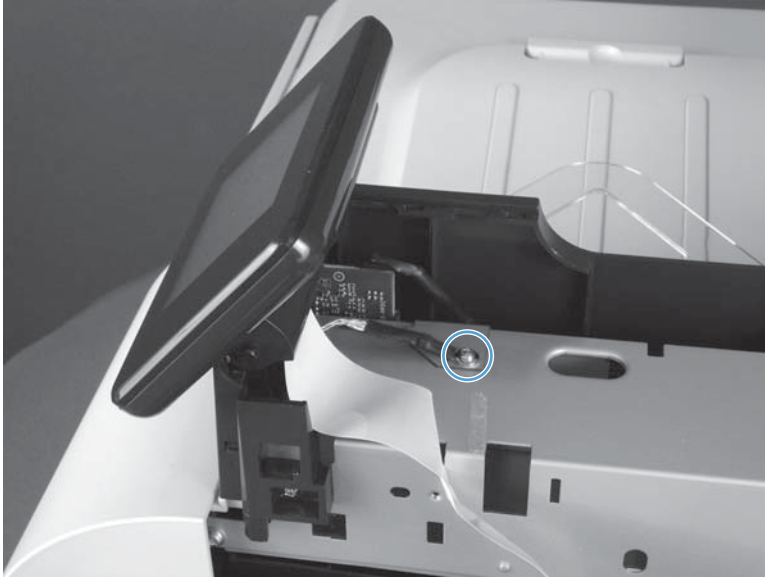

5. Carefully slide the control panel toward the right side of the product to release the left most hinge pin.

Figure 1-44 Remove the control panel (5 of 6)

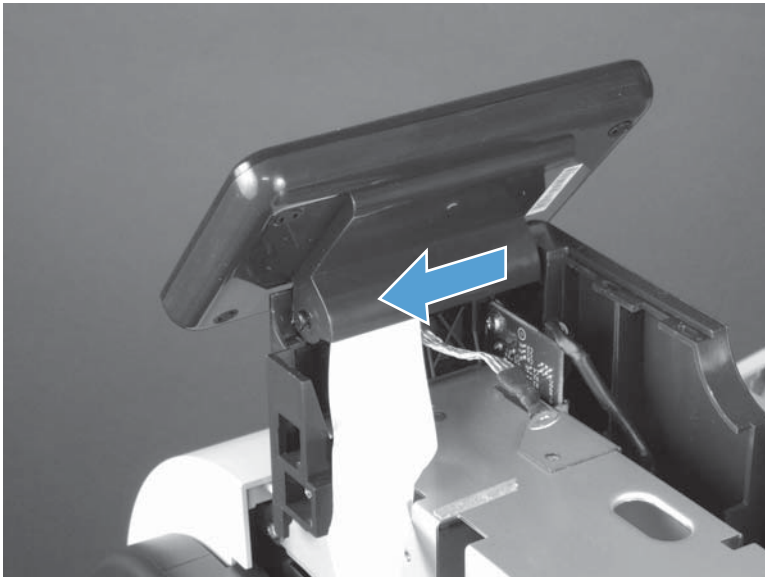

6. Rotate the left side of the control panel up (callout 1) and away from the product to release the right most hinge pin, and then slide the control panel to the left (callout 2) to remove it.

Figure 1-45 Remove the control panel (6 of 6)

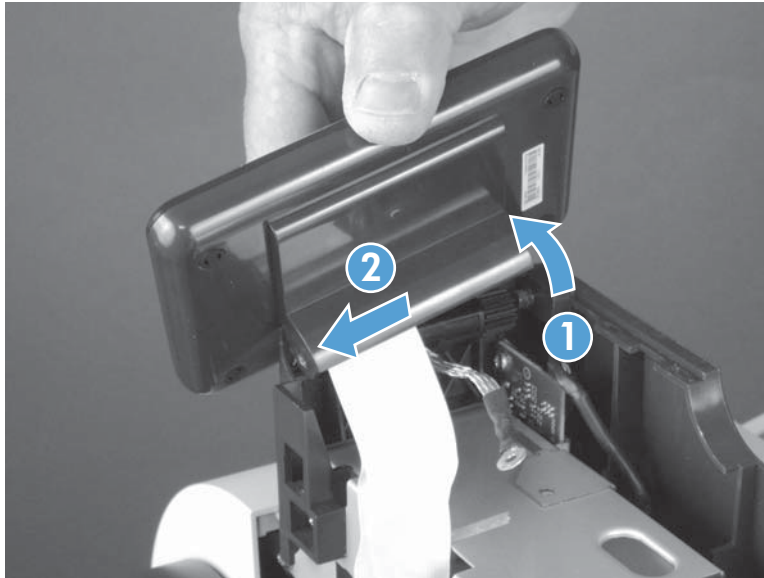

USB PCA

Before proceeding, remove the following components:

- Control panel. See [Control panel on page 32](#).
- Right-rear cover. See [Right-rear cover on page 48](#).
- Left cover. See [Left cover on page 50](#).
- Left-upper cover. See [Left-upper cover on page 54](#).
- Right-upper rear cover. See [Right-upper rear cover on page 55](#).
- Rear cover. See [Rear cover on page 56](#).
- Upper-right cover. See [Upper-right cover on page 66](#).
- Document feeder. See [Document feeder on page 73](#).
- Image scanner. See [Image scanner on page 77](#).
- Interconnect board (ICB). See [Interconnect board \(ICB\) on page 88](#).

 **TIP:** Removing the ICB makes it easier to connect the control panel FFC when the control panel is reinstalled.

Remove the USB PCA

 **CAUTION:**  ESD sensitive component.

1. Disconnect one connector (callout 1).

Figure 1-46 Remove the USB PCA (1 of 3)

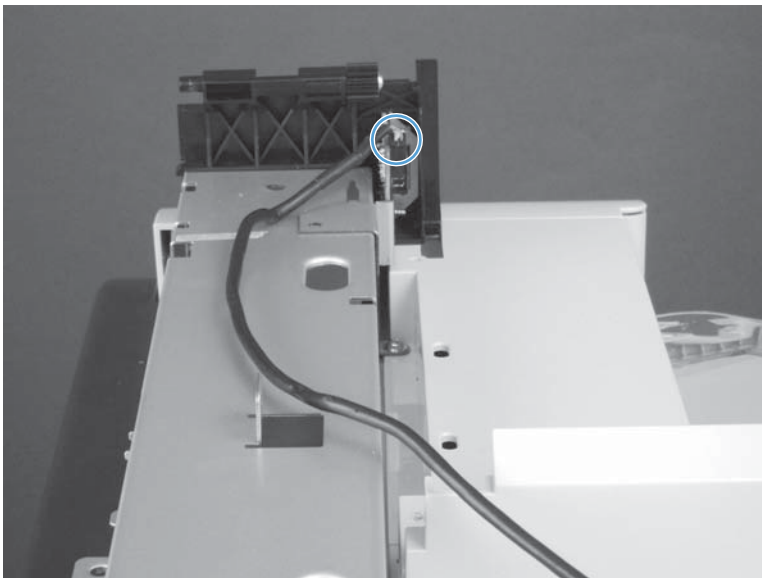

2. Remove one screw (callout 1).

Figure 1-47 Remove the USB PCA (2 of 3)

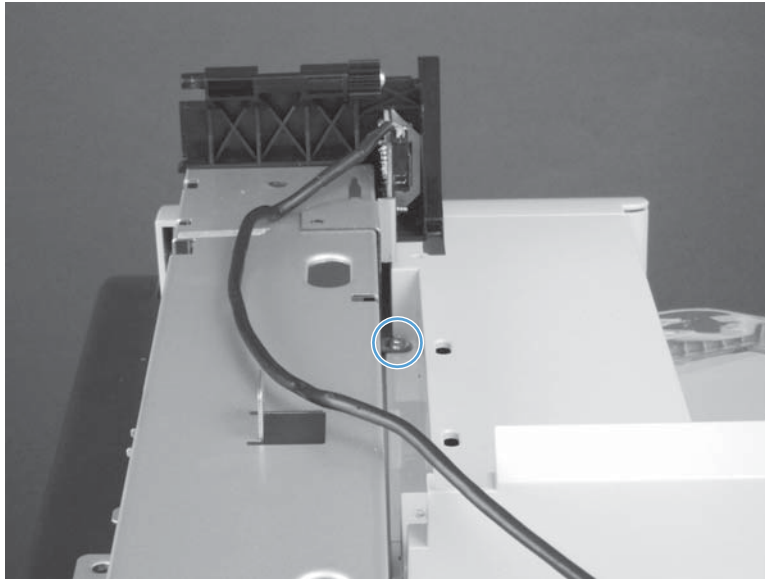

3. Remove the PCA.

Figure 1-48 Remove the USB PCA (3 of 3)

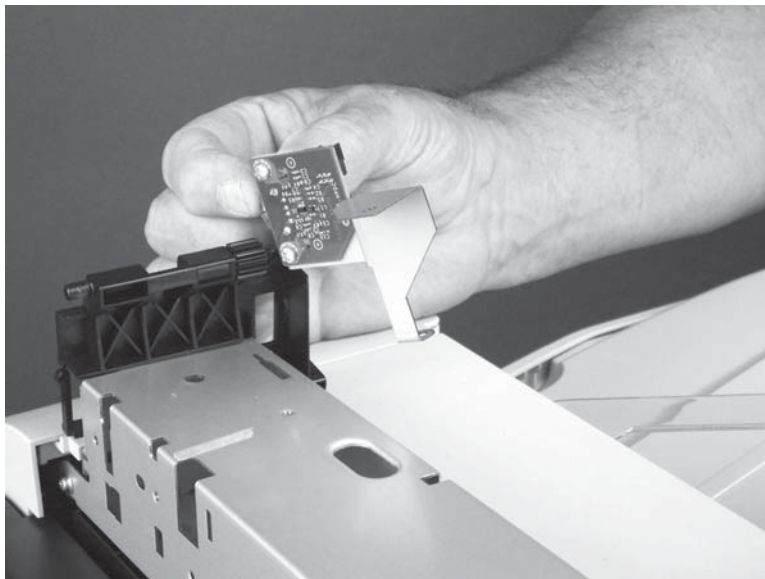

Control panel friction mount

Before proceeding, remove the following components:

- Control panel. See [Control panel on page 32](#).
- USB PCA. See [USB PCA on page 36](#).
- Right-rear cover. See [Right-rear cover on page 48](#).
- Left cover. See [Left cover on page 50](#).
- Left-upper cover. See [Left-upper cover on page 54](#).
- Right-upper rear cover. See [Right-upper rear cover on page 55](#).
- Rear cover. See [Rear cover on page 56](#).
- Upper-right cover. See [Upper-right cover on page 66](#).
- Document feeder. See [Document feeder on page 73](#).
- Image scanner. See [Image scanner on page 77](#).

Remove the control panel friction mount

Use a small flat blade screw driver to carefully pry the friction mount straight up and off of the press fit pin (callout 1).

⚠ CAUTION: The pin is easily broken. Be very careful when removing the friction mount assembly.

Figure 1-49 Remove the control panel friction mount

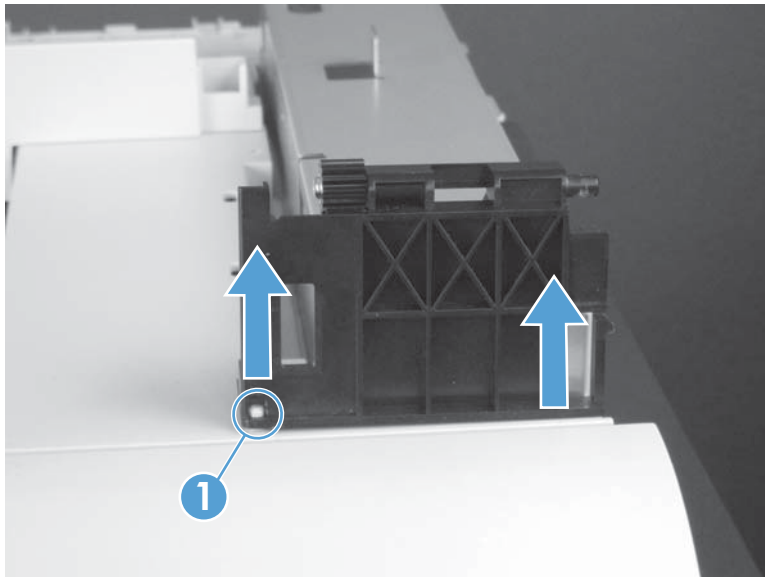

Right door (optional paper feeder)

1. Open the right door.

Figure 1-50 Remove the right door; optional paper feeder (1 of 3)

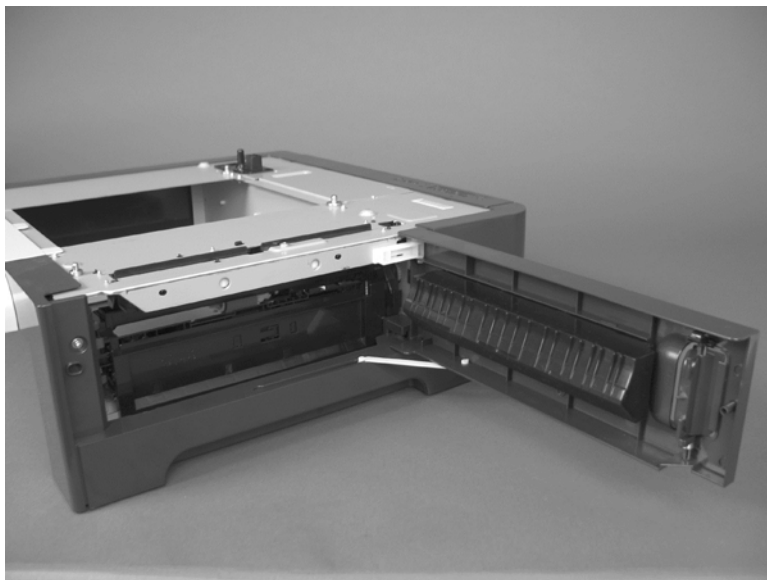

2. Release one tab (callout 1), and then slide the stopper toward the right side of the product to remove it.

Figure 1-51 Remove the right door; optional paper feeder (2 of 3)

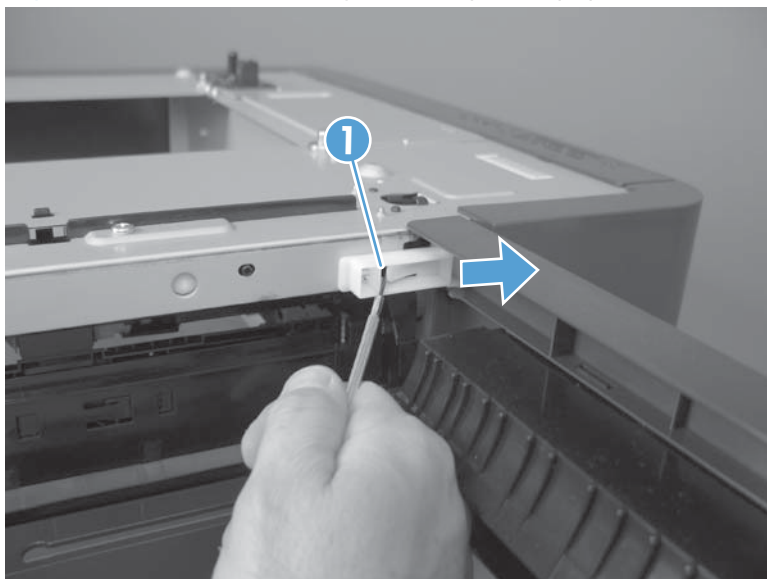

3. Support the door, and then release the door-retainer arm at the bottom of the door. Raise the door to release the lower hinge pin, and then remove the door.

Figure 1-52 Remove the right door; optional paper feeder (3 of 3)

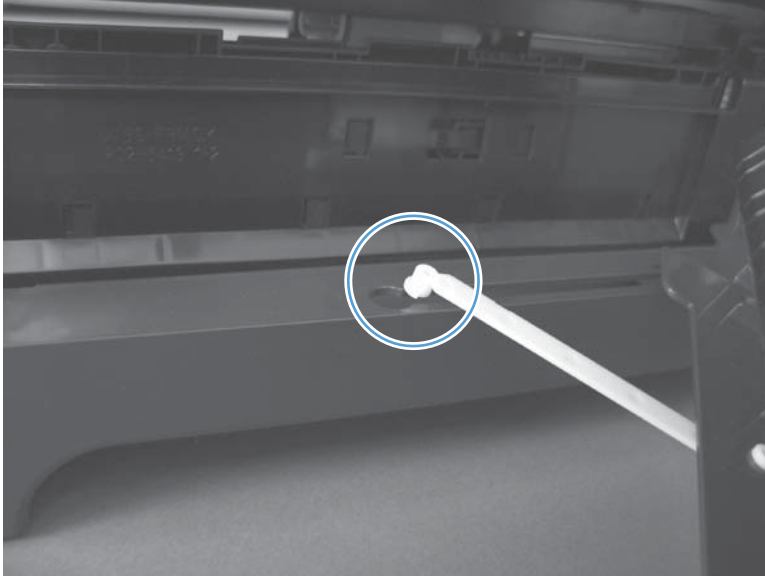

External panels, covers, and doors

Identification and location

 **NOTE:** Your product might not appear exactly as the one shown in the photos in this chapter. Although some photos do not show the ADF/scanner unit, the procedures in this chapter are appropriate for the product.

Figure 1-53 Product base, external panels, covers, doors; identification and location

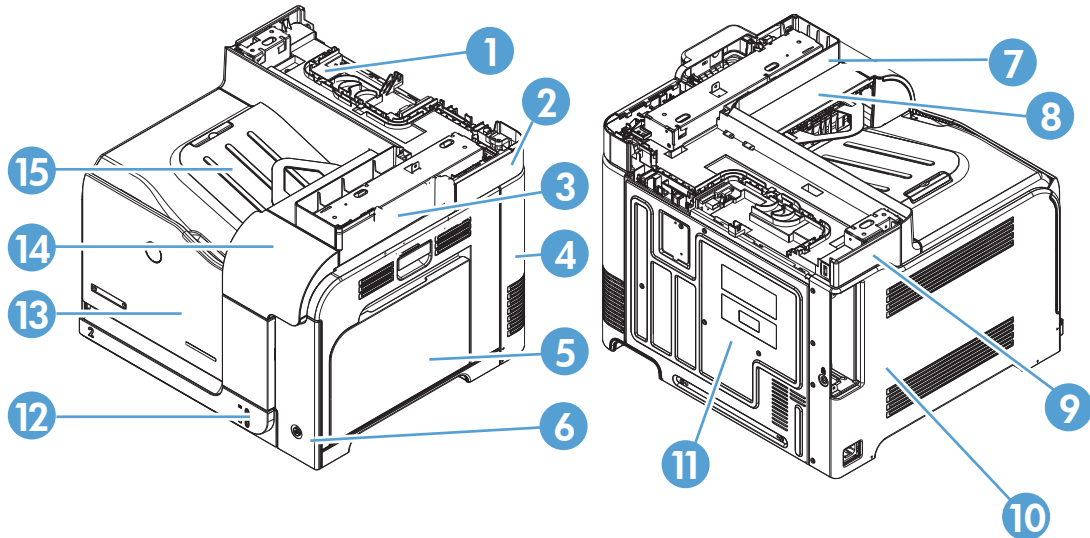

Table 1-2 Product base, external panels, covers, doors; identification and location

Item	Description
1	Rear-top cover (see Rear-top cover on page 71)
2	Right-top cover (see Right-top cover on page 64)
3	Right-rear cover (see Right-rear cover on page 48)
4	Right-door assembly (see Right-door assembly on page 44)
5	Right-front cover (see Right-front cover on page 58)
6	Upper-right cover (see Upper-right cover on page 66)
7	Delivery cover (see Delivery cover on page 62)
8	Left-upper cover (see Left-upper cover on page 54)
9	Left cover (see Left cover on page 50)
10	Rear cover (see Rear cover on page 56)
11	Tray (see Tray 2 and 3 on page 14)
12	Front-door assembly (see Front-door assembly on page 27)
13	Front-upper cover (see Front-upper cover on page 42)
14	Front-top cover (see Front-top cover on page 69)

Front-upper cover

Remove the front-upper cover

1. Open the right door and the front door.

Figure 1-54 Remove the front-upper cover (1 of 4)



2. Remove one screw (callout 1).

Figure 1-55 Remove the front-upper cover (2 of 4)



3. Remove one screw (callout 1).

Figure 1-56 Remove the front-upper cover (3 of 4)



4. Lift the cover up to release it, and then remove the cover.



NOTE: The cover might be difficult to remove. It might require some flexing to release it.

Figure 1-57 Remove the front-upper cover (4 of 4)



Right-door assembly

1. Open the right-door assembly.

Figure 1-58 Remove the right-door assembly (1 of 8)

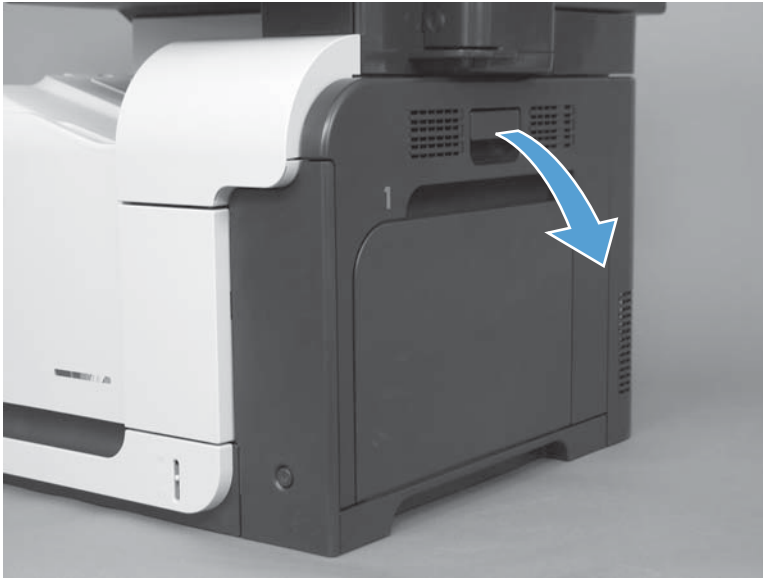

2. Close the secondary transfer assembly.

Figure 1-59 Remove the right-door assembly (2 of 8)

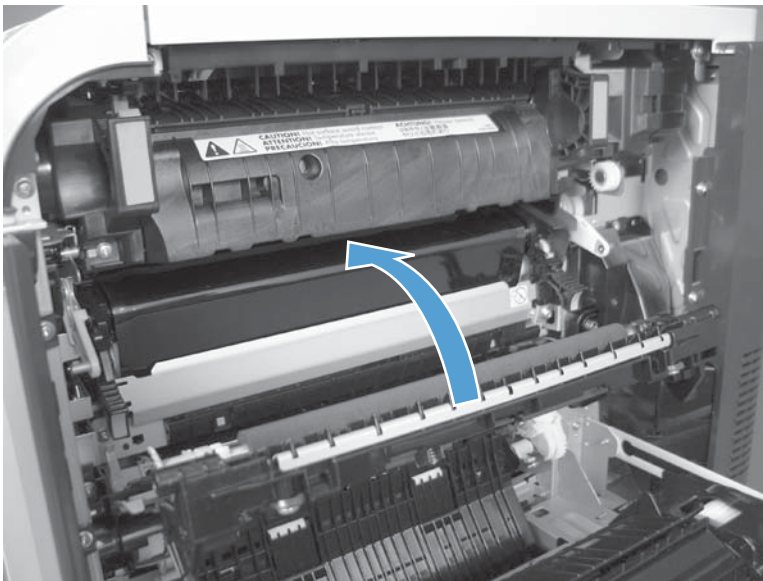

3. Remove three screws (callout 1).

Figure 1-60 Remove the right-door assembly (3 of 8)

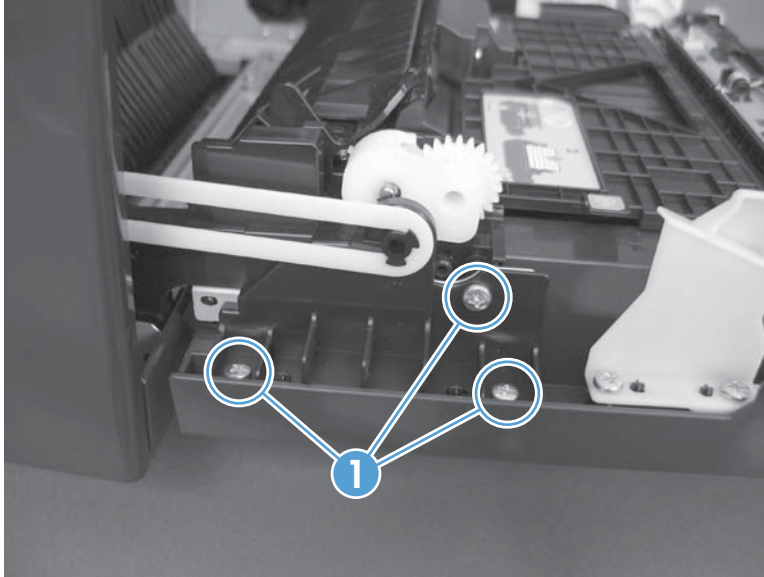

4. Carefully release one link arm.

Figure 1-61 Remove the right-door assembly (4 of 8)



5. Remove one screw (callout 1), and then remove the cover (callout 2).

Figure 1-62 Remove the right-door assembly (5 of 8)

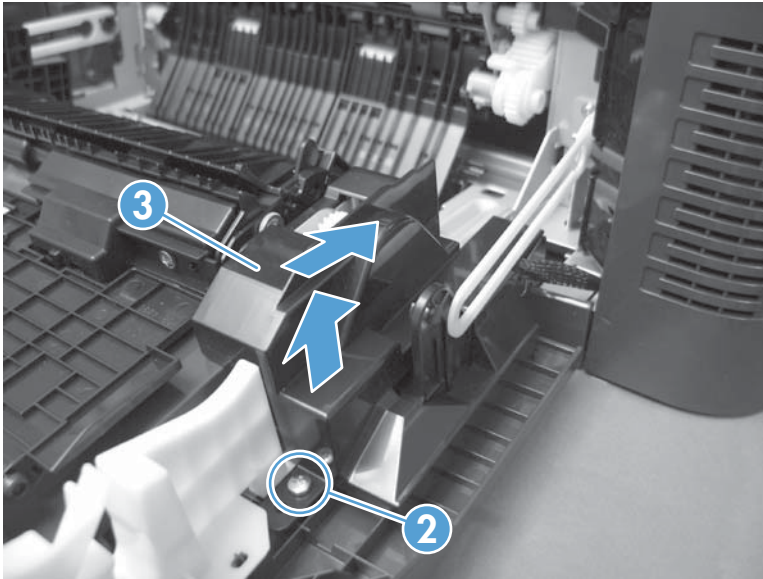

6. Disconnect two connectors (callout 1), and then release the wire harness from the guide (callout 2).

 **TIP:** It is easier to disconnect the lower connector if you first remove the wire harnesses from the guide.

Figure 1-63 Remove the right-door assembly (6 of 8)



7. Remove two screws (callout 1).

Figure 1-64 Remove the right-door assembly (7 of 8)

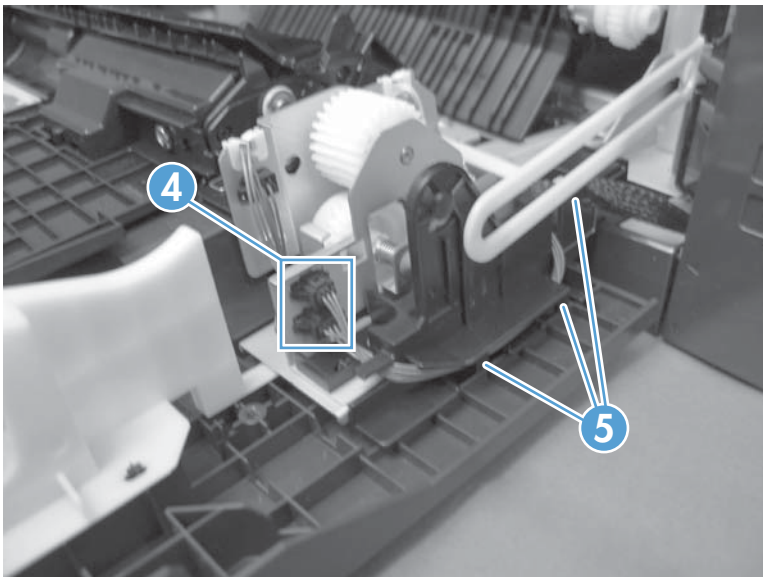
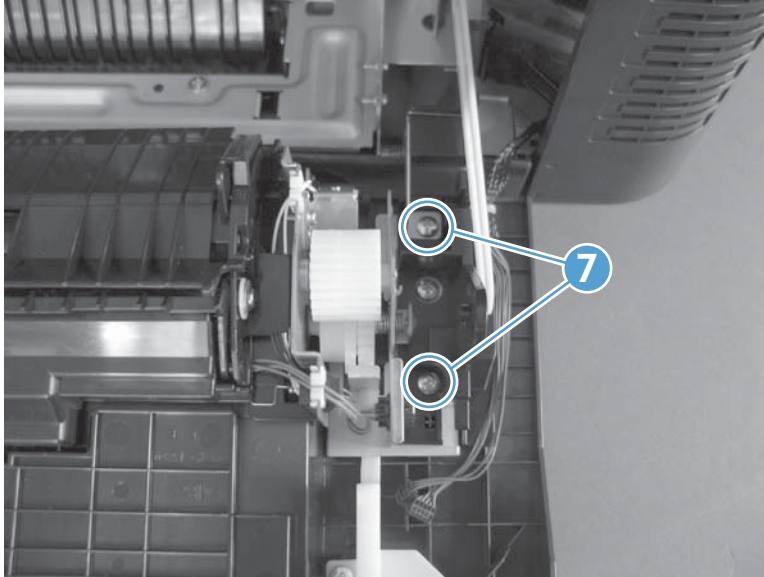

8. Remove the right-door assembly.

Figure 1-65 Remove the right-door assembly (8 of 8)

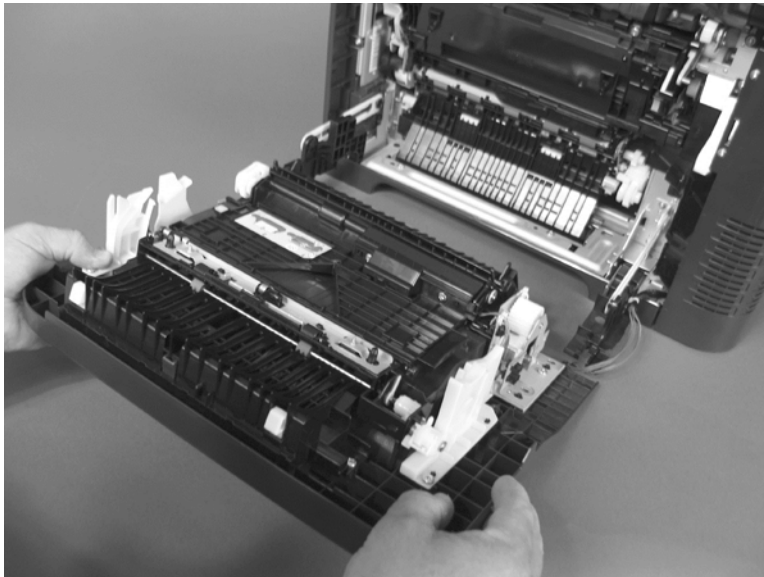

Right-rear cover

1. Open the right-door assembly.

Figure 1-66 Remove the right-rear cover (1 of 3)

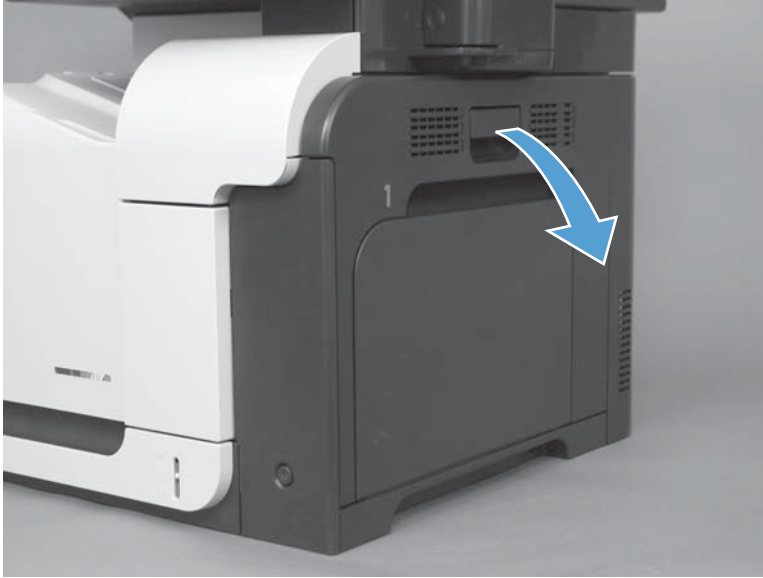

2. Remove two screws (callout 1) and release one tab (callout 2).

Figure 1-67 Remove the right-rear cover (2 of 3)

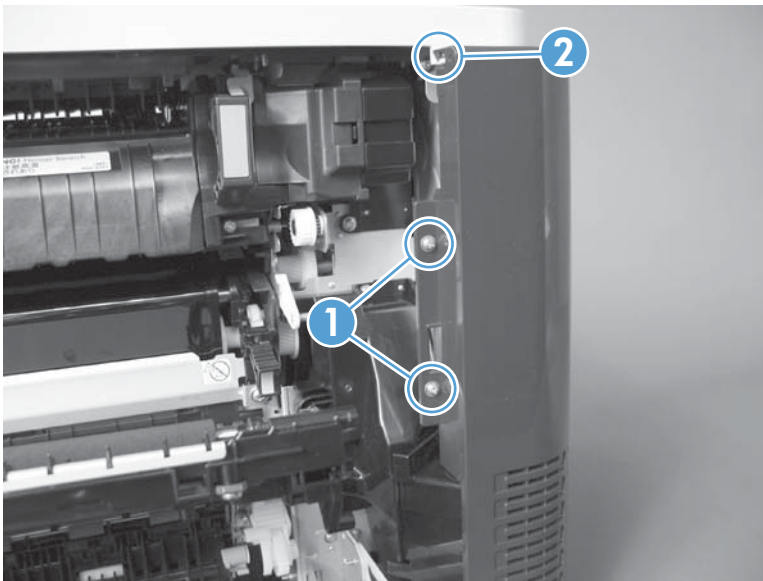

3. Rotate the bottom of the cover away from the product, and then remove the cover.

Figure 1-68 Remove the right-rear cover (3 of 3)

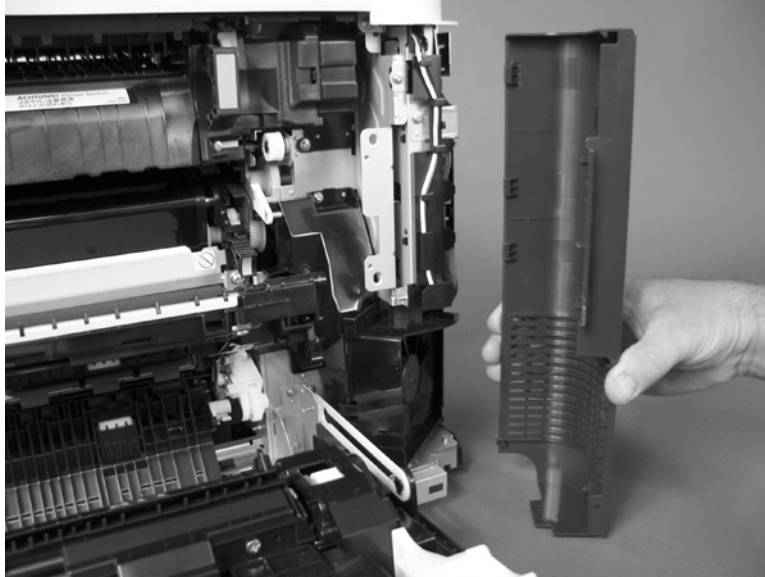

Left cover

1. Remove four screws (callout 1).

Figure 1-69 Remove the left cover (1 of 5)

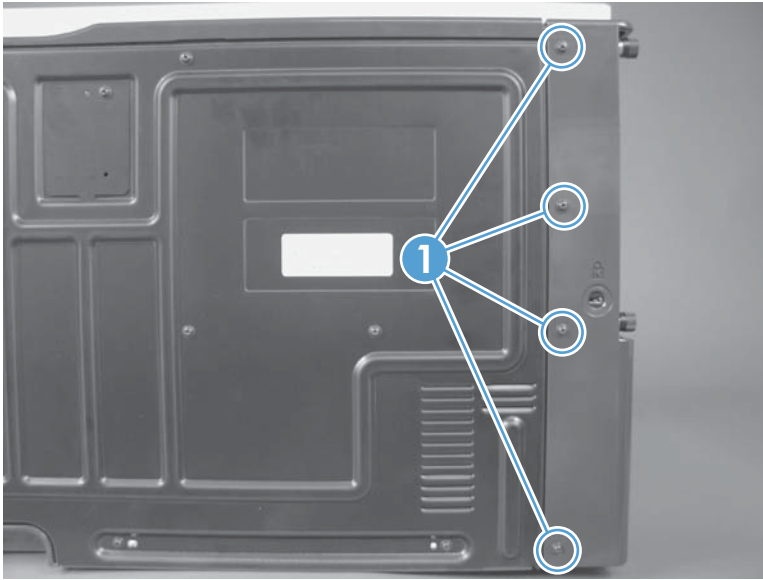

2. Release the rear edge of the cover, and slightly separate the cover from the product.

Figure 1-70 Remove the left cover (2 of 5)



3. The figure below shows the cover removed so that you can see the mounting tab locations. **Before proceeding**, note the location of the mounting tabs.

CAUTION: One tab (callout 2) is easily damaged when removing the cover. Be careful when removing the cover.

Figure 1-71 Remove the left cover (3 of 5)

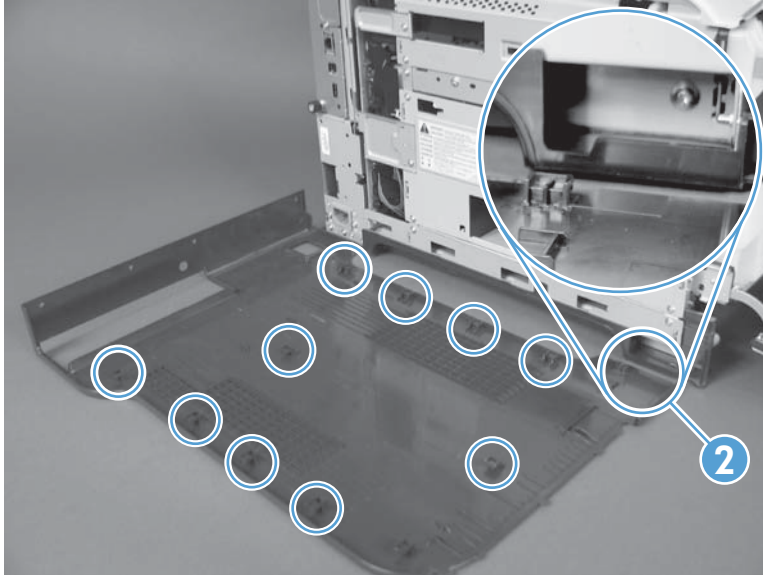

4. Use your thumb to press in on the lower-front portion of the cover (callout 1 near the dashed circle in the figure below), and then slightly slide the cover away (callout 2) from the front door to release one tab.

CAUTION: You must flex the cover enough to release the front edge of the cover, but do not damage the tab at the bottom-front edge of the cover. See callout 2 in [Figure 1-71 Remove the left cover \(3 of 5\) on page 51](#).

Figure 1-72 Remove the left cover (4 of 5)

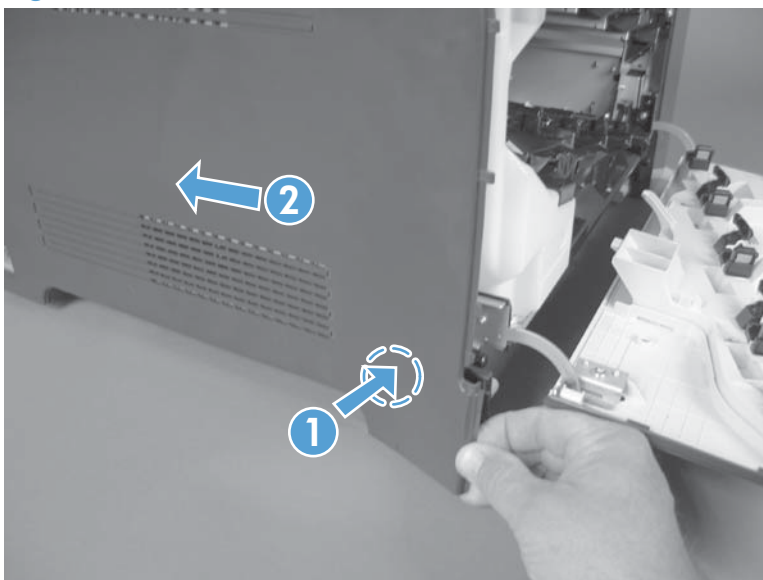

5. Slide the cover toward the rear of the product and rotate it away from the product and then remove the cover.

Figure 1-73 Remove the left cover (5 of 5)

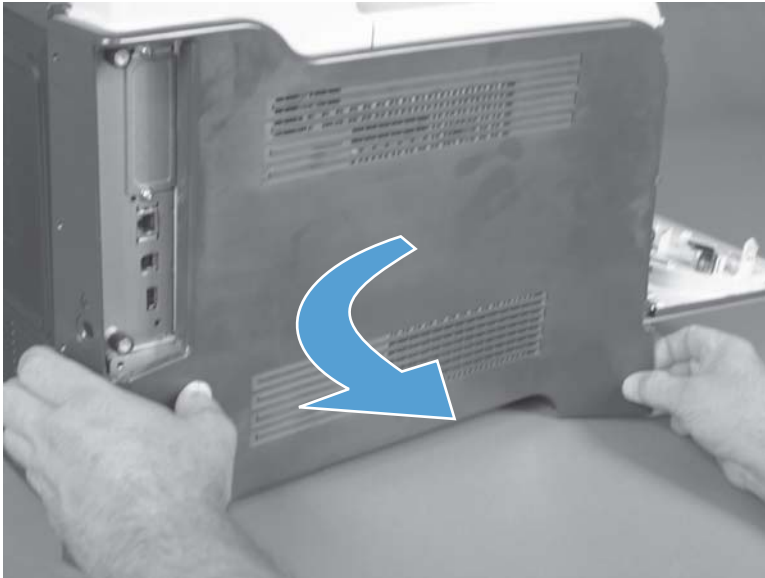

Rear-upper cover

1. Remove two screws (callout 1).

Figure 1-74 Remove the rear-upper cover (1 of 2)

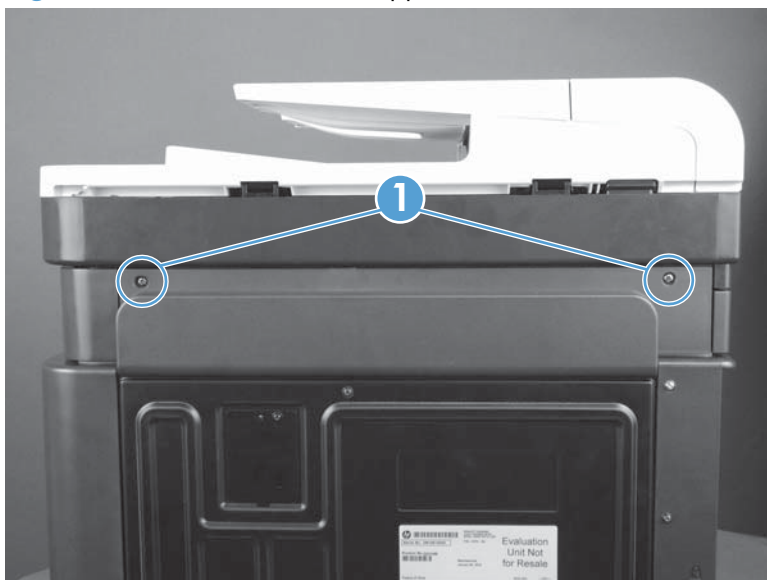

2. Rotate the cover away from the product to remove it. See example below under Remove the right-upper cover.

Figure 1-75 Remove the rear-upper cover (2 of 2)



Left-upper cover

Before proceeding, remove the following components:

- Rear-upper cover. See [Rear-upper cover on page 53](#).

Remove the left-upper cover

Release one tab and remove the cover.

Figure 1-76 Remove the left-upper cover

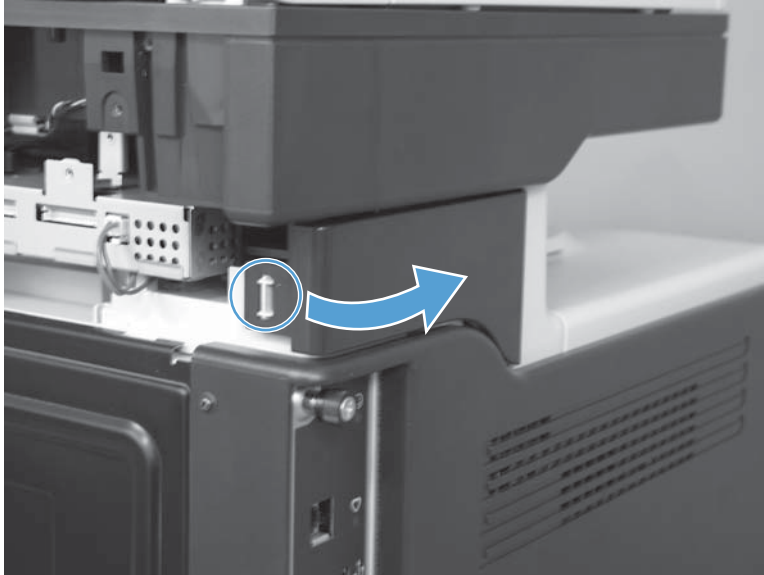

Right-upper rear cover

Before proceeding, remove the following components:

- Rear-upper cover. See [Rear-upper cover on page 53](#).

Remove the right-upper cover

Rotate the cover away from the product (callout 1) to release it, and then slide it toward the rear of the product (callout 2) to remove it.

Figure 1-77 Remove the right-upper cover

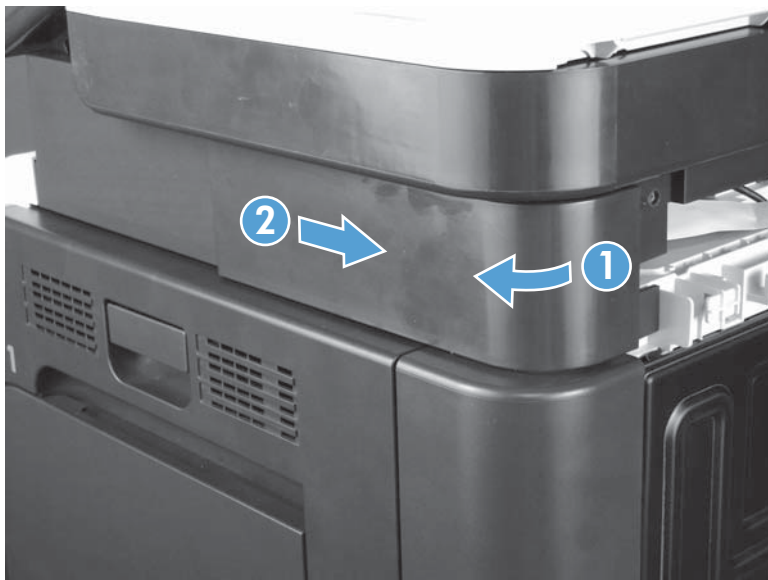

Rear cover

Before proceeding, remove the following components:

- Right-rear cover. See [Right-rear cover on page 48](#).
- Left cover. See [Left cover on page 50](#).
- Rear-upper cover. See [Rear-upper cover on page 53](#).

Remove the rear cover

1. Remove eight screws (callout 1).

Figure 1-78 Remove the rear cover (1 of 2)

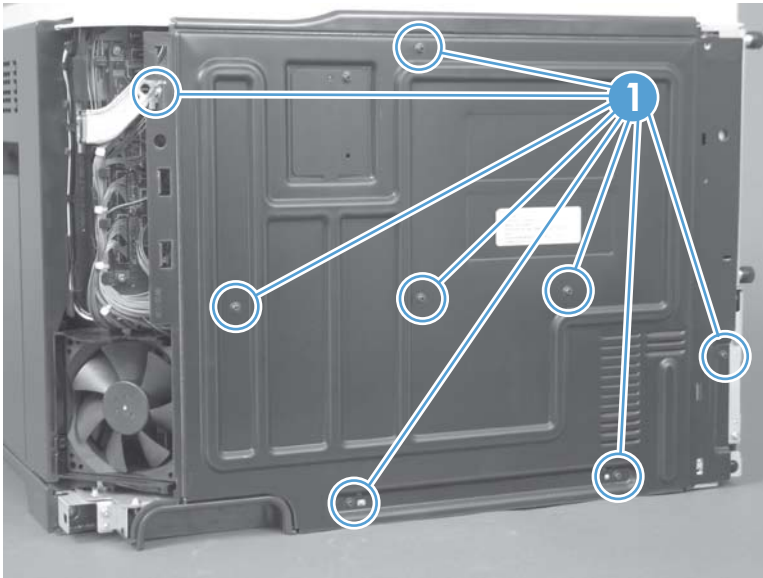

2. Slide the cover toward the fan side of the product, and then remove the rear cover.

Figure 1-79 Remove the rear cover (2 of 2)



Right-front cover

Before proceeding, remove the following components:

- Front-upper cover. See [Front-upper cover on page 42](#).

Remove the right-front cover

 **NOTE:** Be careful. When removing the cover, do not dislodge the power button. If the button is dislodged, see [Reinstall the power button on page 61](#) to reinstall it.

1. Remove one screw (callout 1).

Figure 1-80 Remove the right-front cover (1 of 5)

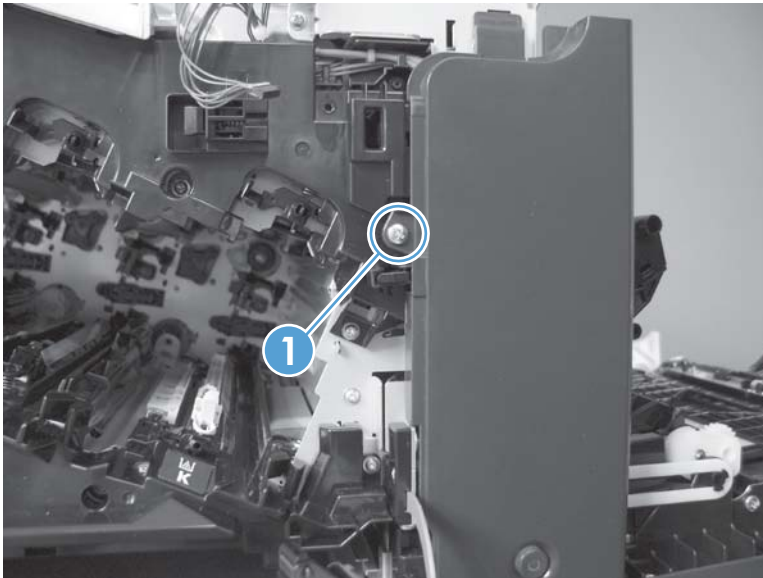

2. Remove two screws (callout 2).

Figure 1-81 Remove the right-front cover (2 of 5)

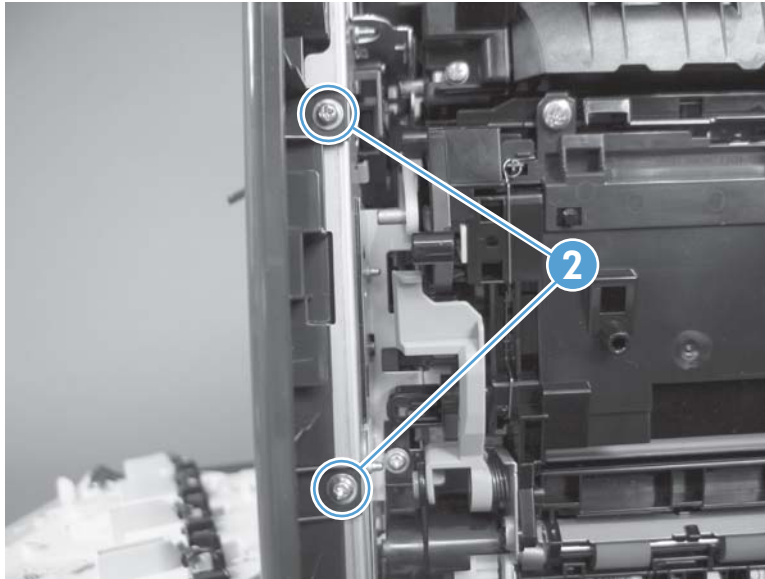

3. Before you proceed, take note of the tab locations at the bottom of the cover.

Figure 1-82 Remove the right-front cover (3 of 5)

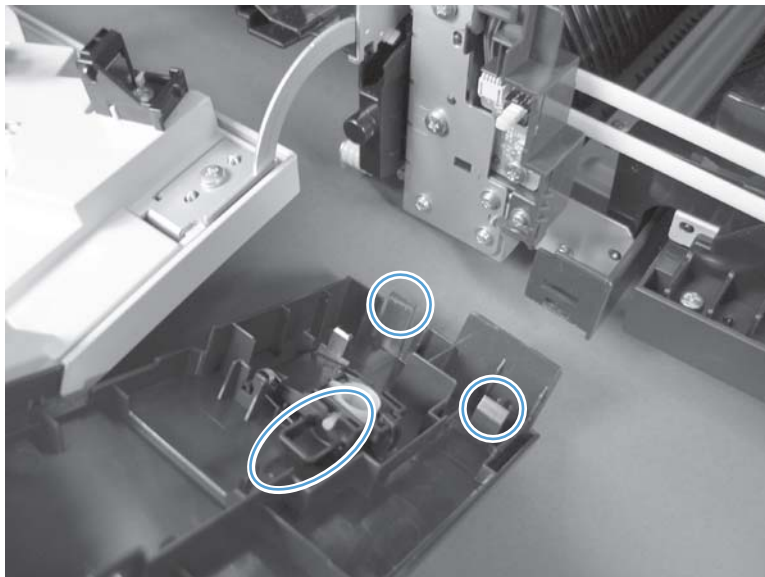

4. Pull down on the cover to release three tabs (callout 3).

 **TIP:** It might be easier if you position the product at the edge of the work surface so that there is a space for the cover to slide downward. Or, you might try inserting a small flat blade screwdriver behind the cover, and carefully pry the cover away from the product as you pull down on the cover to release the tabs.

Figure 1-83 Remove the right-front cover (4 of 5)



5. Rotate the bottom of the cover away from the product, and then pull down on the cover to remove it.

Figure 1-84 Remove the right-front cover (5 of 5)

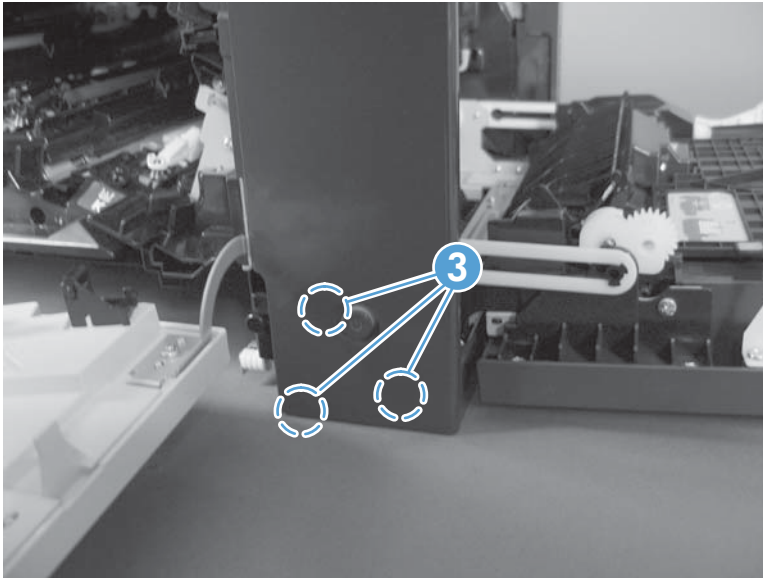
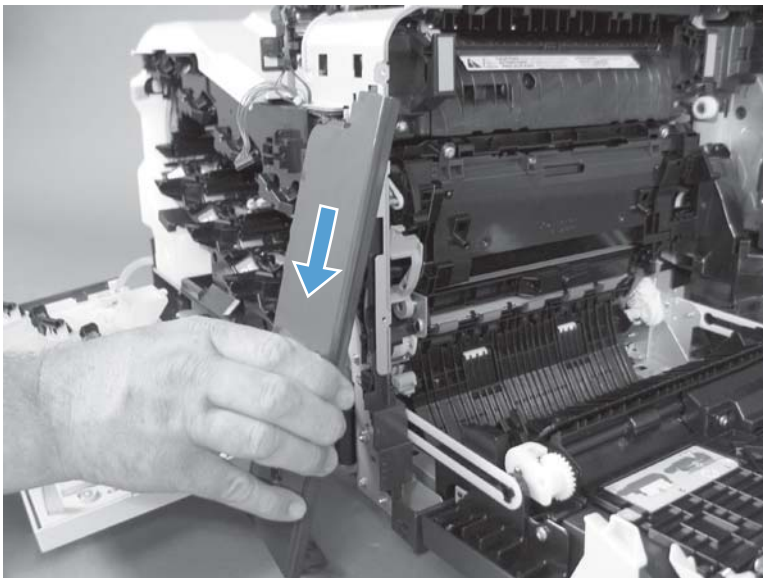

Reinstall the power button

Snap the power button into the holders on the cover. Make sure that the spring is correctly installed.

Figure 1-85 Reinstall the power button

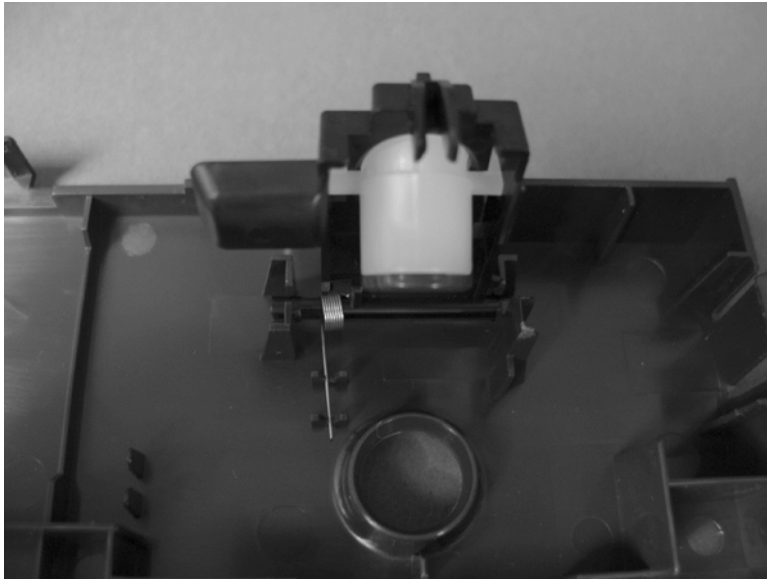

Delivery cover

Before proceeding, remove the following components:

- Front-upper cover. See [Front-upper cover on page 42](#).
- Rear-upper cover. See [Rear-upper cover on page 53](#).
- Left-upper cover. See [Left-upper cover on page 54](#).
- Upper-right cover. See [Upper-right cover on page 66](#).
- Document feeder. See [Document feeder on page 73](#).
- Image scanner. See [Image scanner on page 77](#).

Remove the delivery cover

1. Remove three screws.

Figure 1-86 Remove the delivery cover (1 of 3)

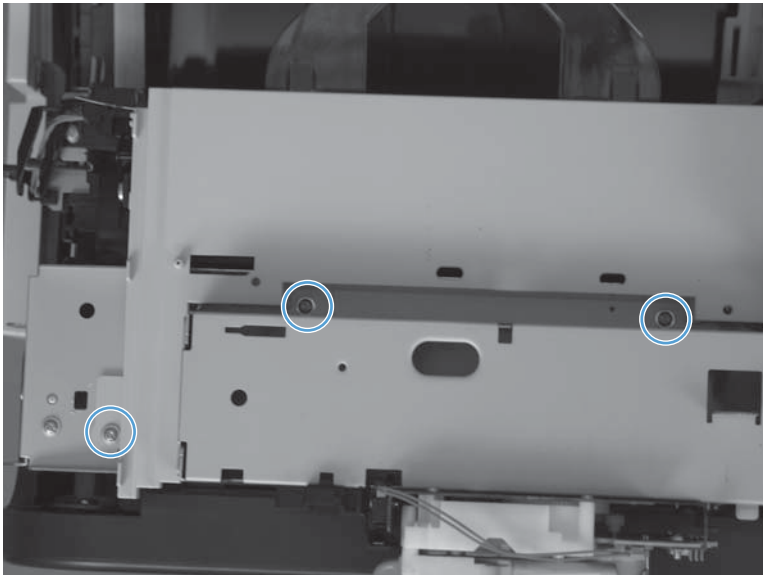

2. Lift up (callout 1) and slide the delivery cover (callout 2).

Figure 1-87 Remove the delivery cover (2 of 3)

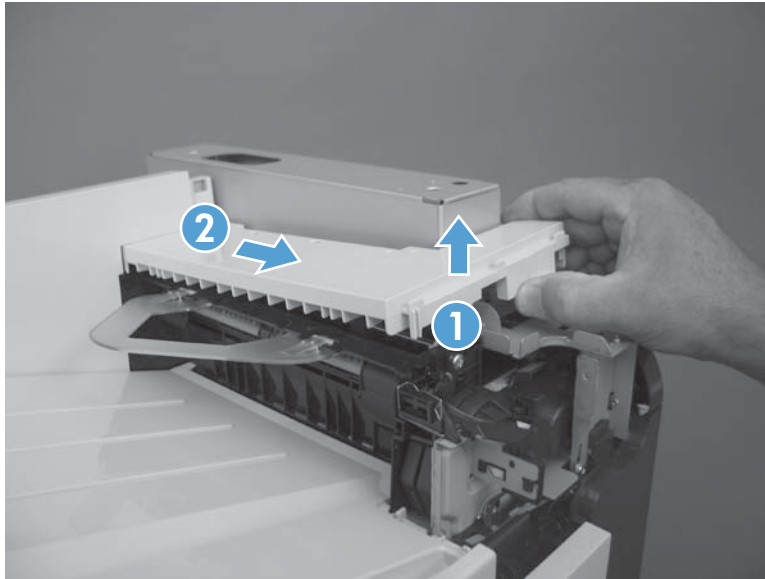

3. Remove the delivery cover.

Figure 1-88 Remove the delivery cover (3 of 3)

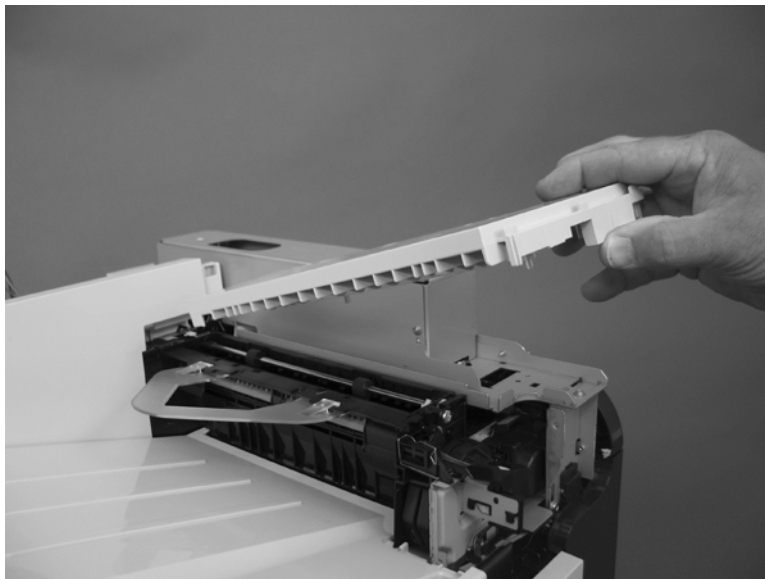

Right-top cover

Before proceeding, remove the following components:

- Rear-upper cover. See [Rear-upper cover on page 53](#).
- Left-upper cover. See [Left-upper cover on page 54](#).
- Document feeder. See [Document feeder on page 73](#).
- Image scanner. See [Image scanner on page 77](#).

Remove the right-top cover

1. Remove three screws.

Figure 1-89 Remove the right-top cover (1 of 2)

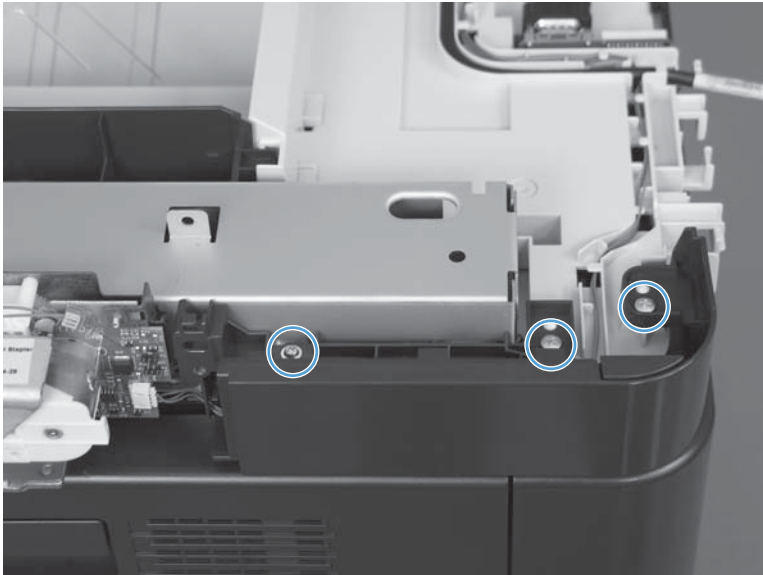

2. Disconnect one connector (callout 1), remove the wire harness from its retainer (callout 2), and remove the cover.

Figure 1-90 Remove the right-top cover (2 of 2)

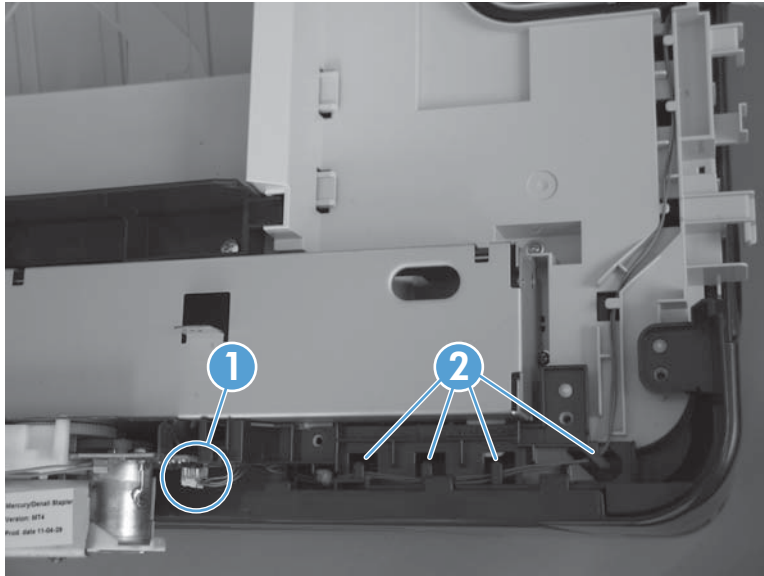

Upper-right cover

Before proceeding, remove the following components:

- Control panel. See [Control panel on page 32](#).
- USB PCA. See [USB PCA on page 36](#).
- Right-rear cover. See [Right-rear cover on page 48](#).
- Left cover. See [Left cover on page 50](#).
- Left-upper cover. See [Left-upper cover on page 54](#).
- Right-upper rear cover. See [Right-upper rear cover on page 55](#).
- Rear cover. See [Rear cover on page 56](#).
- Document feeder. See [Document feeder on page 73](#).
- Image scanner. See [Image scanner on page 77](#).

Remove the upper-right cover

1. Remove one screw.

Figure 1-91 Remove the upper-right cover (1 of 5)

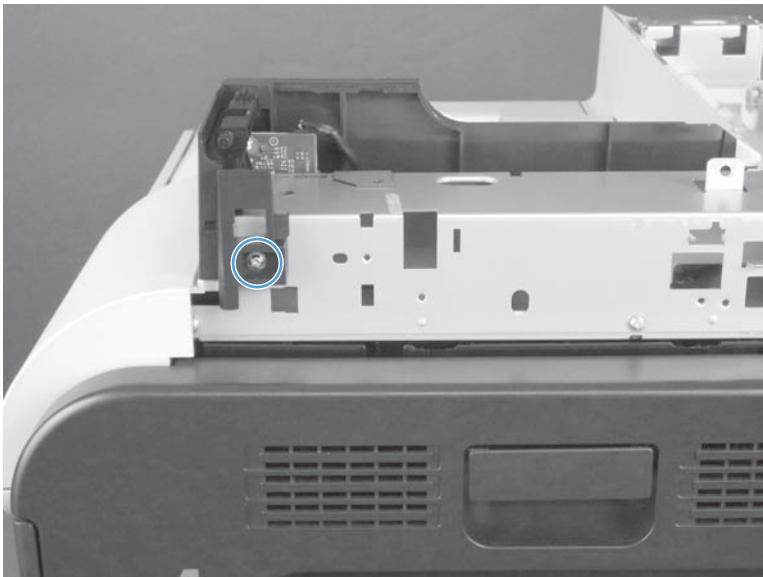

2. Release the USB cable from the retainers (callout 1).

Figure 1-92 Remove the upper-right cover (2 of 5)

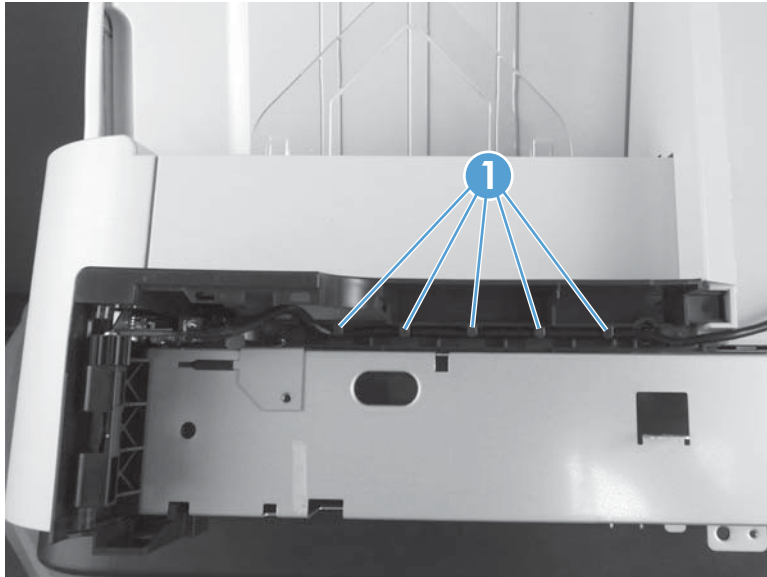

3. Remove two screws.

Figure 1-93 Remove the upper-right cover (3 of 5)

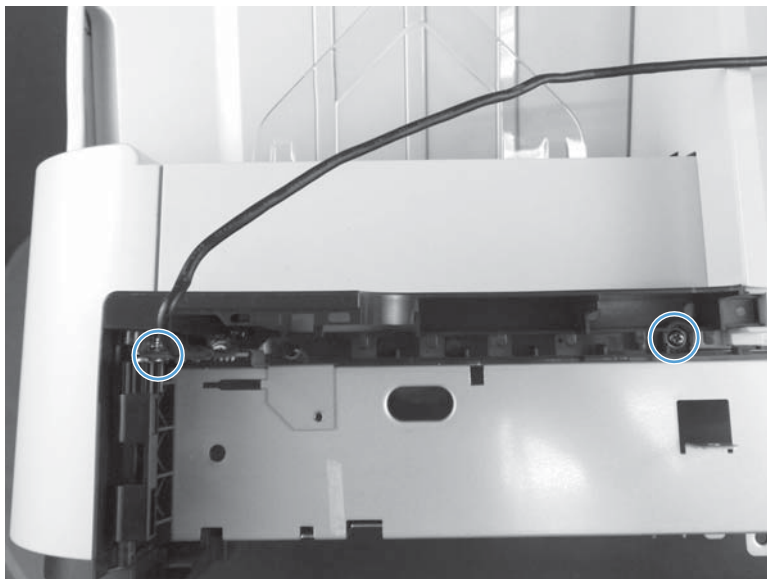

4. Release one tab.

Figure 1-94 Remove the upper-right cover (4 of 5)

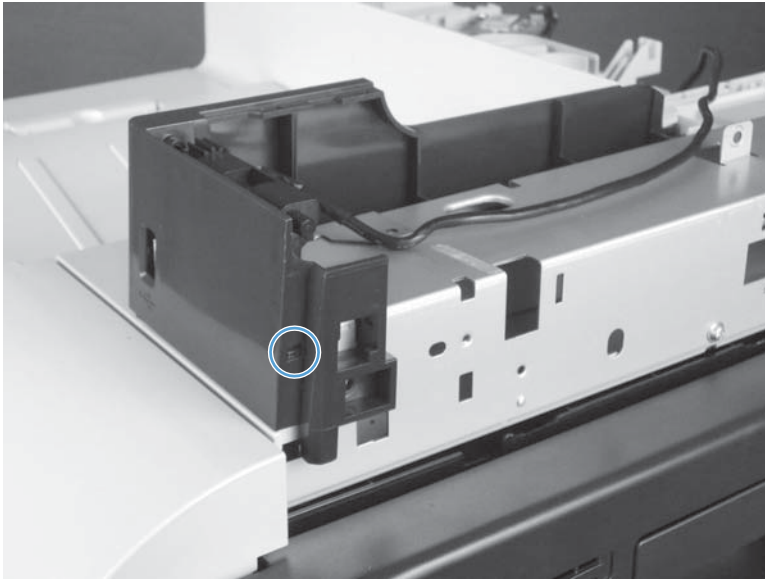

5. Carefully lift the upper-right cover straight up to remove it.

Figure 1-95 Remove the upper-right cover (5 of 5)

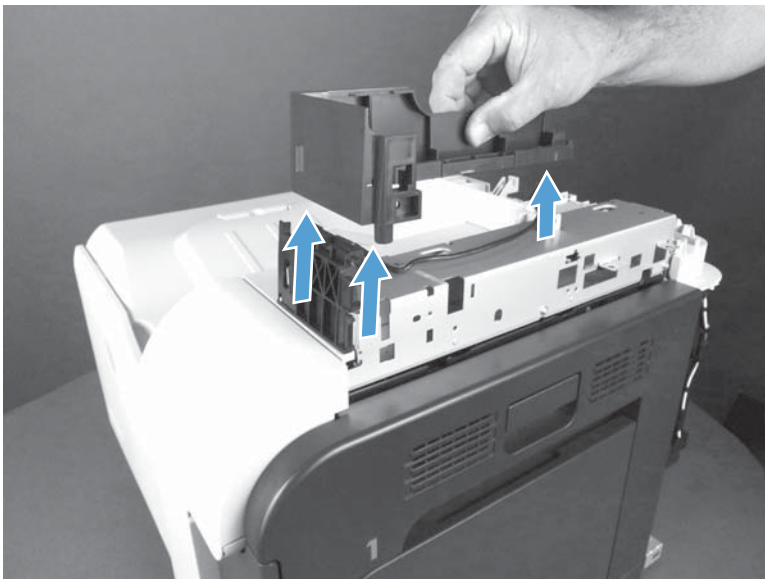

Front-top cover

Before proceeding, remove the following components:

- Rear-upper cover. See [Rear-upper cover on page 53](#).
- Right-rear cover. See [Right-rear cover on page 48](#).
- Left cover. See [Left cover on page 50](#).
- Left-upper cover. See [Left-upper cover on page 54](#).
- Right-upper rear cover. See [Right-upper rear cover on page 55](#).
- Document feeder. See [Document feeder on page 73](#).
- Image scanner. See [Image scanner on page 77](#).
- Wireless PCA. See [Wireless PCA on page 87](#).

Remove the front-top cover

1. Remove one screw (callout 1).

Figure 1-96 Remove the front-top cover (1 of 2)

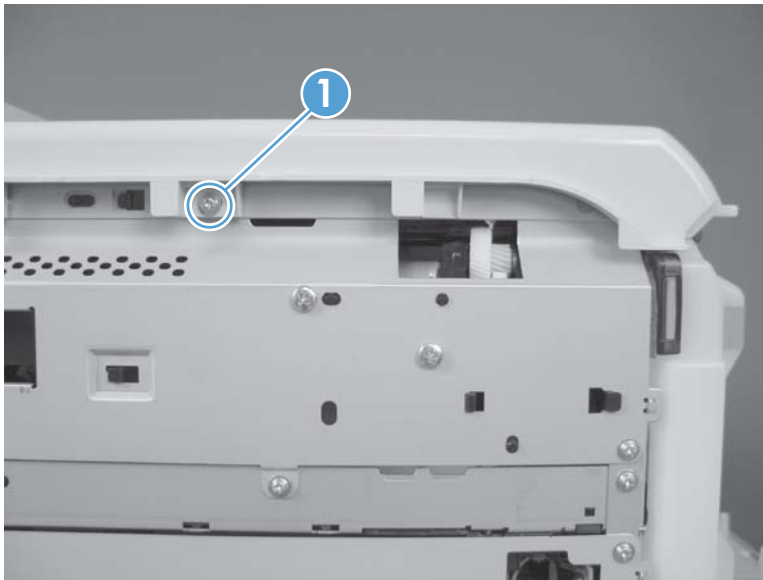

2. Slide the cover toward the left side of the product to release it, and then remove the cover.

Figure 1-97 Remove the front-top cover (2 of 2)

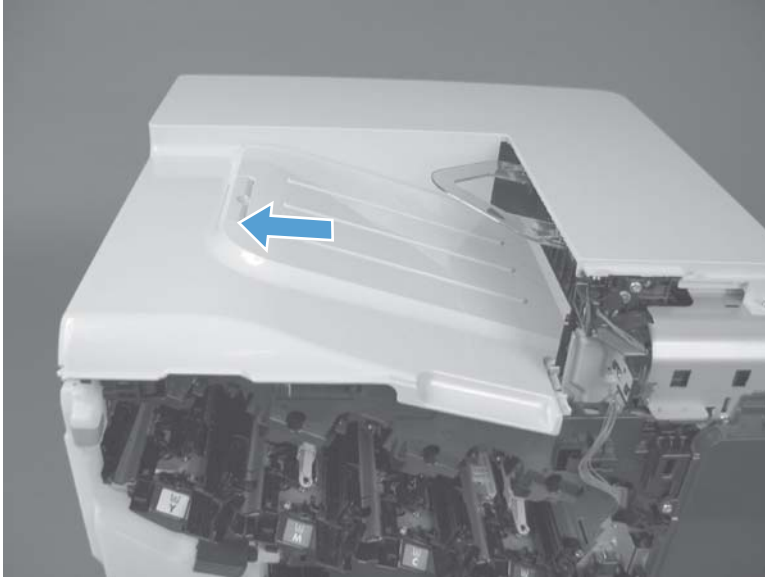

Rear-top cover

Before proceeding, remove the following components:

- Control panel. See [Control panel on page 32](#).
- USB PCA. See [USB PCA on page 36](#).
- Control panel friction mount. See [Control panel friction mount on page 38](#).
- Rear-upper cover. See [Rear-upper cover on page 53](#).
- Left-upper cover. See [Left-upper cover on page 54](#).
- Right-upper rear cover. See [Right-upper rear cover on page 55](#).
- Rear cover. See [Rear cover on page 56](#).
- Delivery cover. See [Delivery cover on page 62](#).
- Front-top cover. See [Front-top cover on page 69](#).
- Document feeder. See [Document feeder on page 73](#).
- Image scanner. See [Image scanner on page 77](#).
- Wireless PCA. See [Wireless PCA on page 87](#).
- Upper-right cover. See [Upper-right cover on page 66](#).
- Interconnect board (ICB). See [Interconnect board \(ICB\) on page 88](#).

 **TIP:** Removing the ICB makes it easier to connect the control panel FFC when the control panel is reinstalled.

Remove the rear-top cover

Remove three screws, and then remove the cover.

Figure 1-98 Remove the rear-top cover

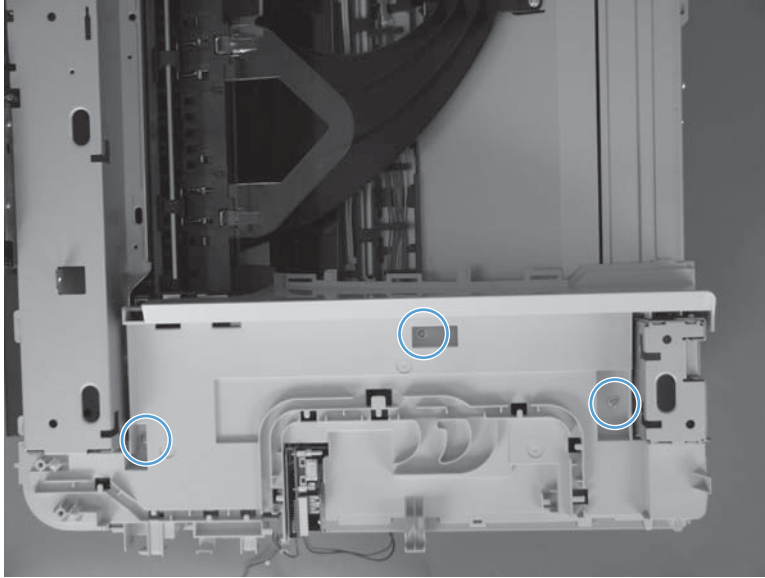

Document feeder and scanner

Document feeder

Before proceeding, remove the following:

- Right-rear cover. See [Right-rear cover on page 48](#).
- Left cover. See [Left cover on page 50](#).
- Rear-upper cover. See [Rear-upper cover on page 53](#).
- Right-upper rear cover. See [Right-upper rear cover on page 55](#).

 **NOTE:** After removing the document feeder assembly, place it on a clean, dry, and smooth surface.

1. Disconnect two connectors (callout 1) and one FFC (callout 2).

Figure 1-99 Remove the document feeder assembly (1 of 4)

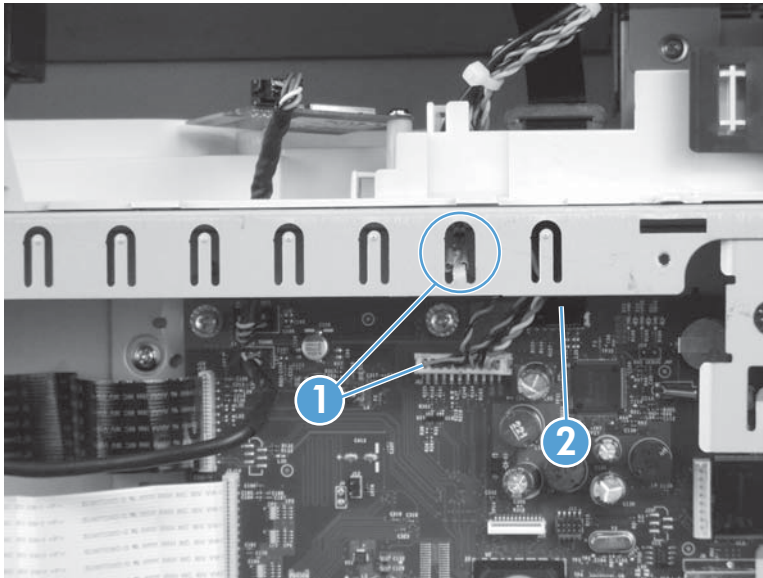

- Carefully feed the wire harnesses up through hole in the chassis (callout 1), and then feed the FFC through the hole in the chassis (callout 2) and through the ferrite (callout 3).

TIP: When you reinstall the document feeder, it might be easier to remove the ferrite from the product, pass the FFC through it, and then reinstall the ferrite in the product with two-sided adhesive tape.

Figure 1-100 Remove the document feeder assembly (2 of 4)

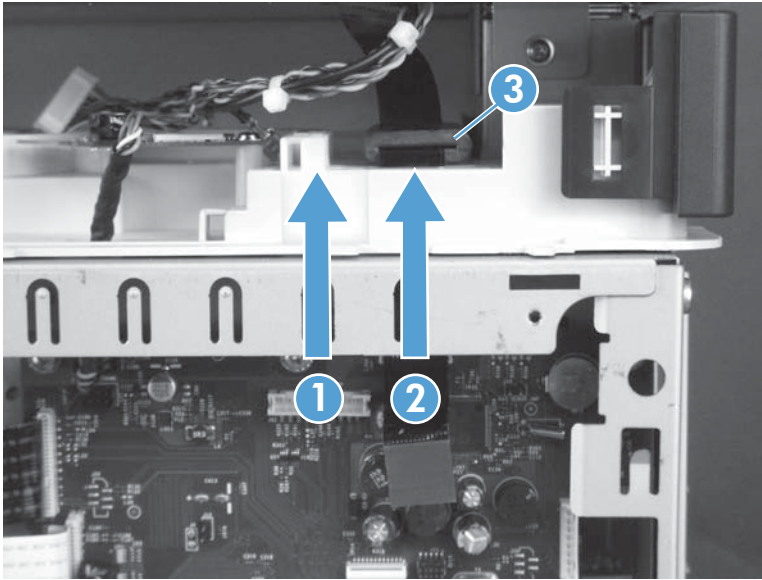

- Open the document feeder, and then lift it straight up until it stops.

Figure 1-101 Remove the document feeder assembly (3 of 4)

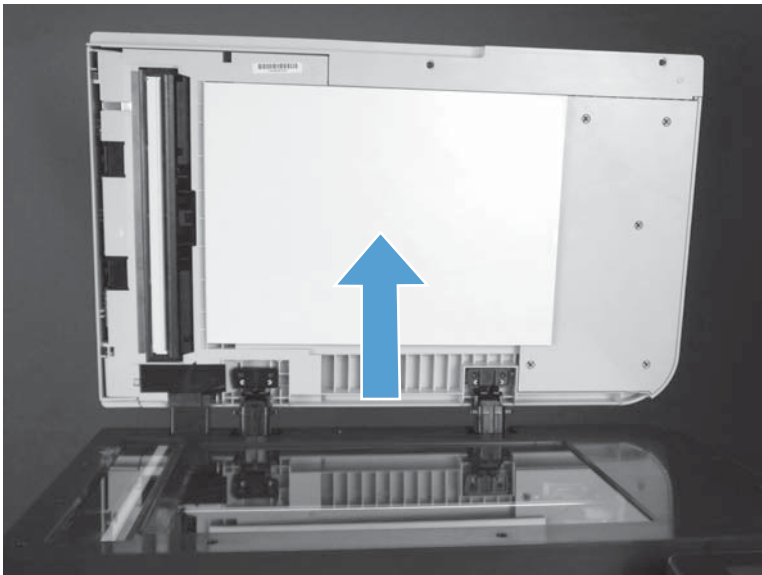

4. Use a small flat blade screw driver to release two tabs (callout 1) on the hinges, and then pull the document feeder straight up and off (callout 2) of the product to remove it.

 **TIP:** Push the screw drive down into the hinge wells to release the tabs.

Figure 1-102 Remove the document feeder assembly (4 of 4)



Reinstall the document feeder

Calibrate a replacement document feeder assembly

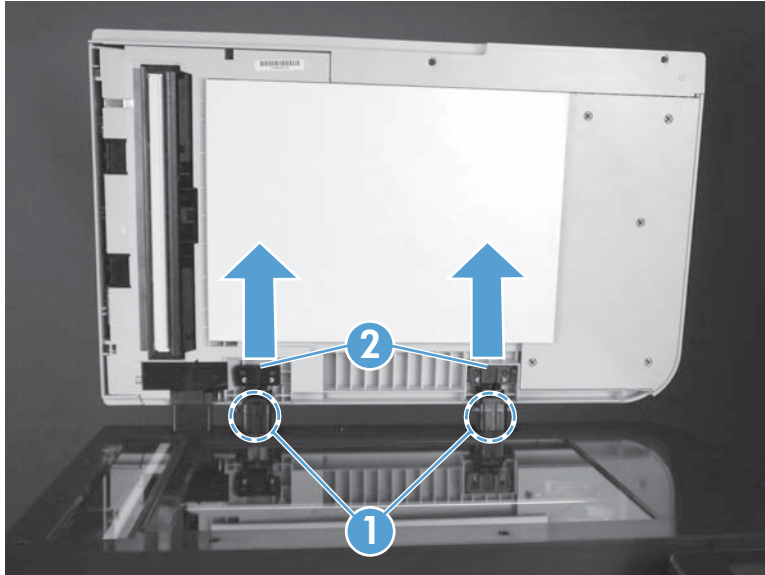
1. On the control-panel Home screen, touch the Setup  Button.
2. Touch the System setup menu.
3. Touch the [Print Quality](#) menu.
4. Touch the [Color Calibration](#) item.
5. Touch the Calibrate now option.
6. Follow the instructions on the control-panel display.

Image scanner

Before proceeding, remove the following components:

- Right-rear cover. See [Right-rear cover on page 48](#).
- Left cover. See [Left cover on page 50](#).
- Rear-upper cover. See [Rear-upper cover on page 53](#).
- Left-upper cover. See [Left-upper cover on page 54](#).
- Right-upper rear cover. See [Right-upper rear cover on page 55](#).
- Document feeder. See [Document feeder on page 73](#).

Remove the image scanner

1. Disconnect one FFC (callout 1), and then carefully feed it through the hole in the chassis (callout 2).

Figure 1-103 Remove the image scanner (1 of 5)

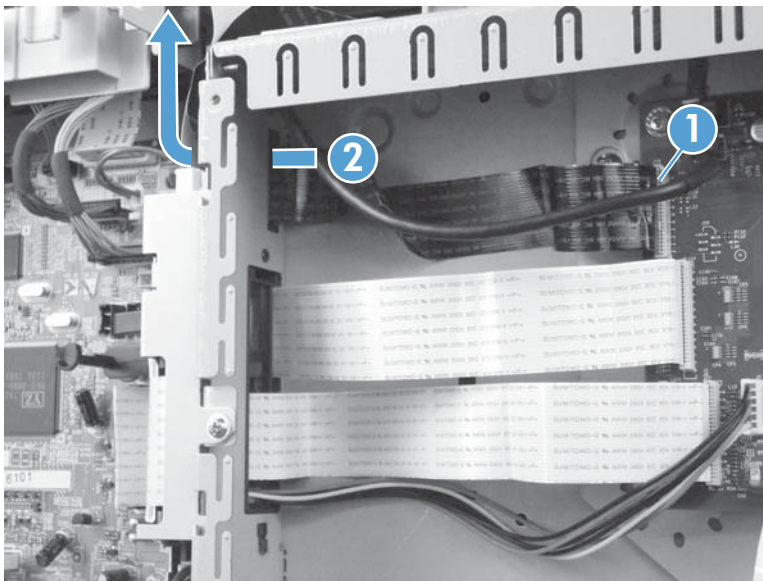

2. Remove two screws on the back side of the scanner.

Figure 1-104 Remove the image scanner (2 of 5)

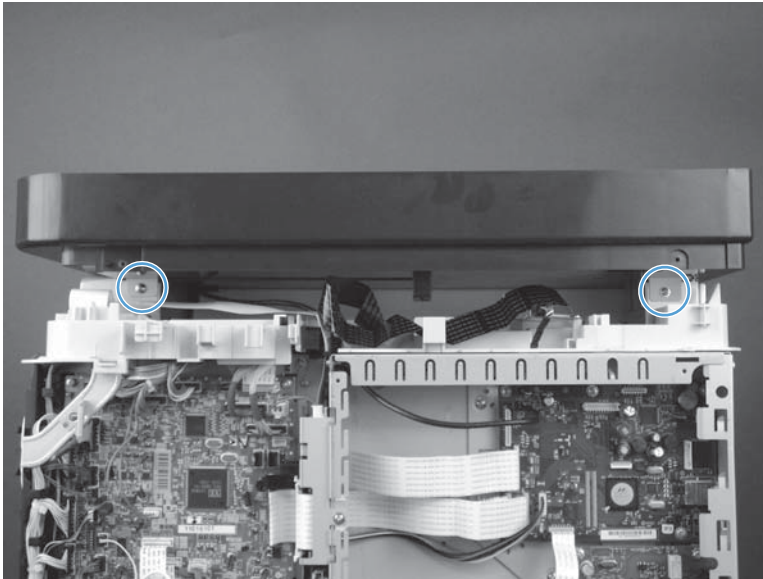

3. Remove one screw on the right side of the scanner.

Figure 1-105 Remove the image scanner (3 of 5)

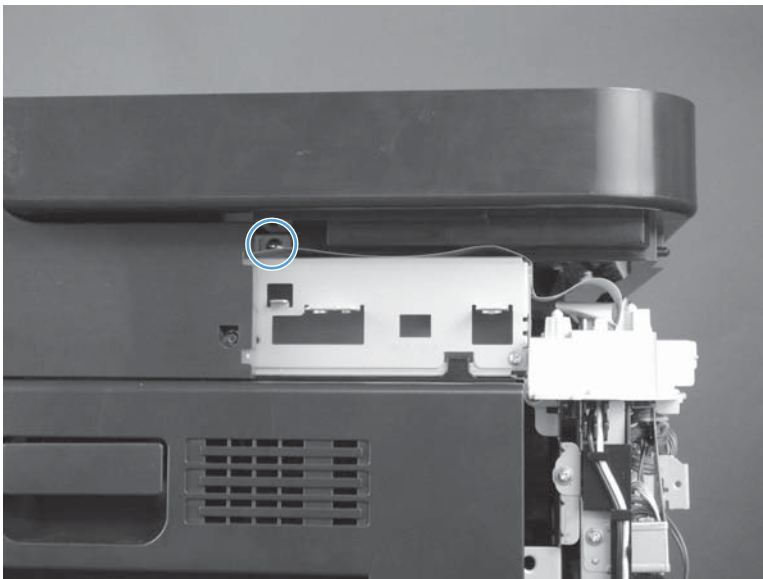

4. Remove one screw on the left side of the scanner.

Figure 1-106 Remove the image scanner (4 of 5)

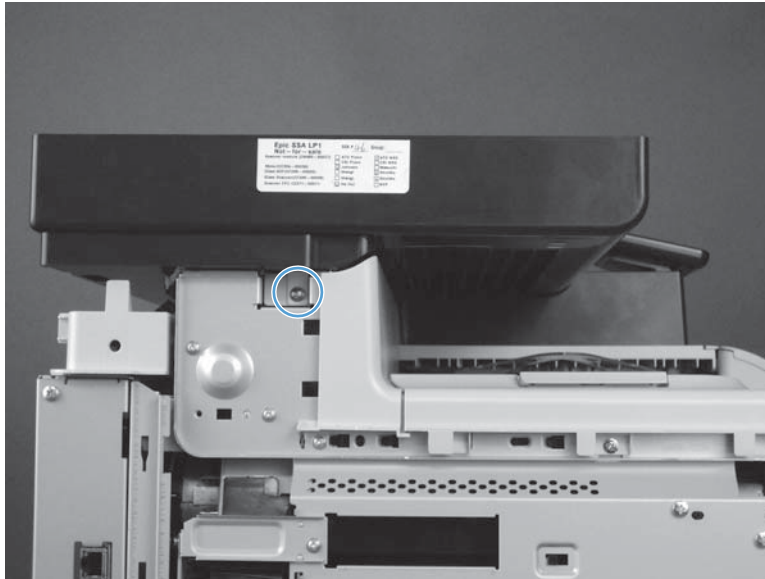

5. Slide the scanner toward the back of the product (callout 1) and then lift it straight up and off of the product (callout 2) to remove it.

Figure 1-107 Remove the image scanner (5 of 5)

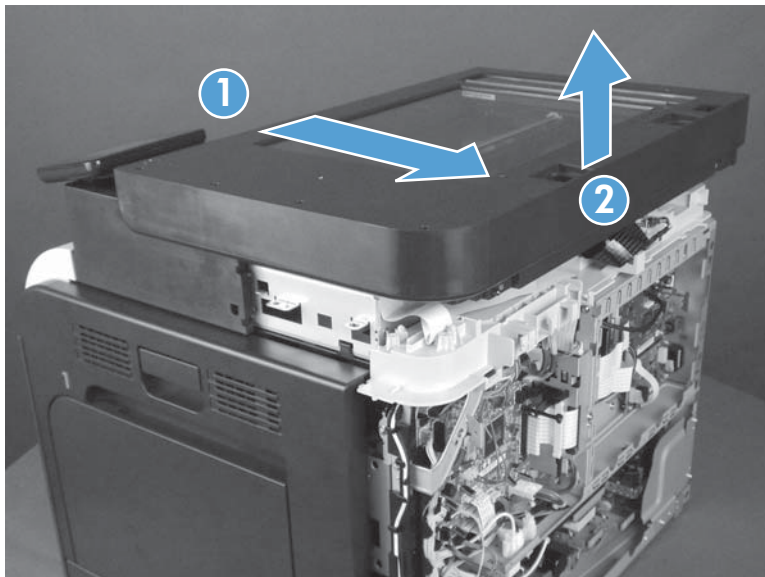

Reinstall the image scanner

Calibrate the scanner

1. On the control-panel Home screen, touch the Setup  Button.
2. Touch the System setup menu.
3. Touch the [Print Quality](#) menu.
4. Touch the [Color Calibration](#) item.
5. Touch the Calibrate now option.
6. Follow the instructions on the control-panel display.

Internal assemblies

 **TIP:** For clarity, some photos in this chapter show components removed that would not be removed to service the product. If necessary, remove the components listed at the beginning of a procedure before proceeding to service the product.

Fuser

 **CAUTION:** The fuser might be hot. Be careful.

1. Open the right-door assembly.

Figure 1-108 Remove the fuser (1 of 2)

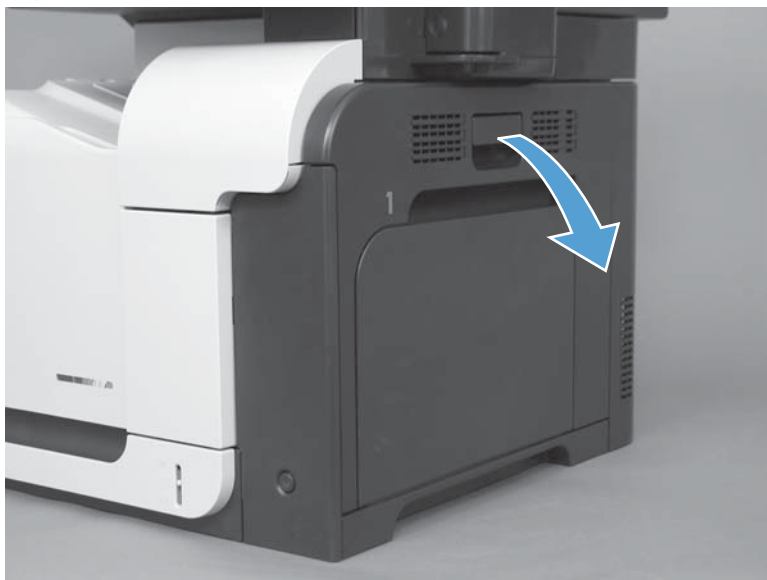

2. Grasp the handles and squeeze the blue release levers.

Pull the fuser straight out of the product to remove it.

Figure 1-109 Remove the fuser (2 of 2)



Formatter PCA

Before proceeding, remove the following components:

- Right-rear cover. See [Right-rear cover on page 48](#).
- Left cover. See [Left cover on page 50](#).
- Rear-upper cover. See [Rear-upper cover on page 53](#).
- Rear cover. See [Rear cover on page 56](#).

Remove the formatter PCA

CAUTION:  ESD sensitive component.

1. Turn the product off and disconnect the power and interface cable.
2. Disconnect all of the connectors from the PCA (callout 1).

Figure 1-110 Remove the formatter (1 of 2)

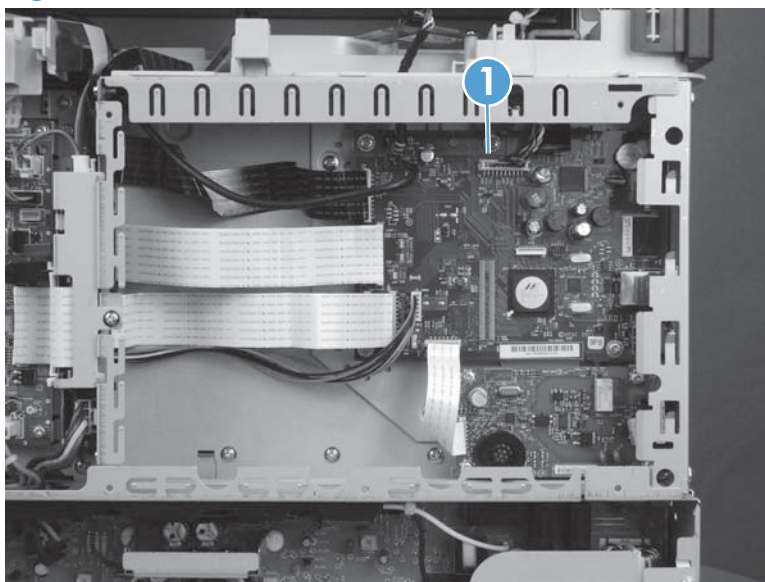

3. Remove five screws (callout 1), and then remove the PCA.

Figure 1-111 Remove the formatter (2 of 2)

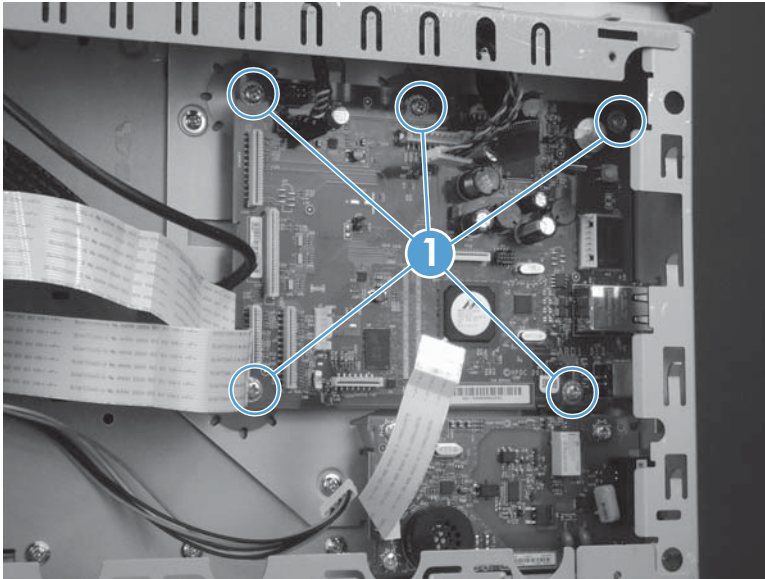

Fax PCA

Before proceeding, remove the following components:

- Right-rear cover. See [Right-rear cover on page 48](#).
- Left cover. See [Left cover on page 50](#).
- Rear-upper cover. See [Rear-upper cover on page 53](#).
- Rear cover. See [Rear cover on page 56](#).

Remove the fax PCA and cable

CAUTION:  ESD sensitive component.

1. Disconnect one connector (callout 1).

Figure 1-112 Remove the fax PCA (1 of 2)

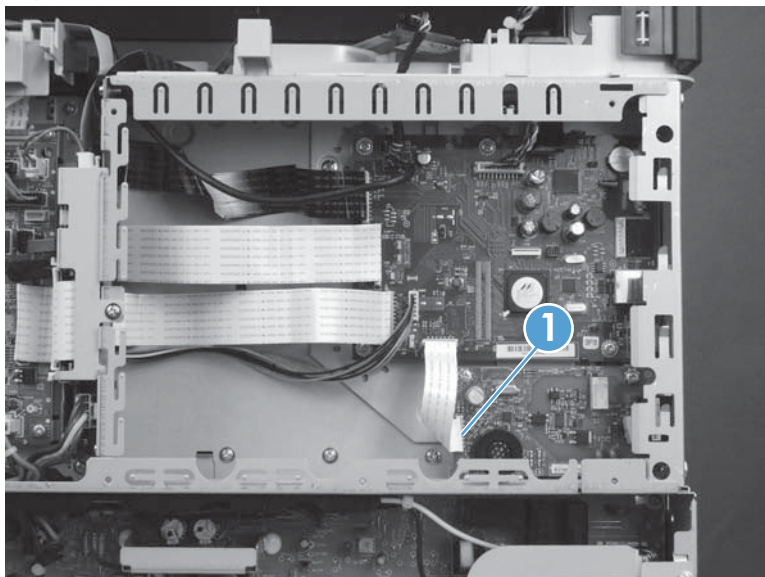

2. Remove four screws (callout 1), and then remove the PCA.

Figure 1-113 Remove the fax PCA (2 of 2)

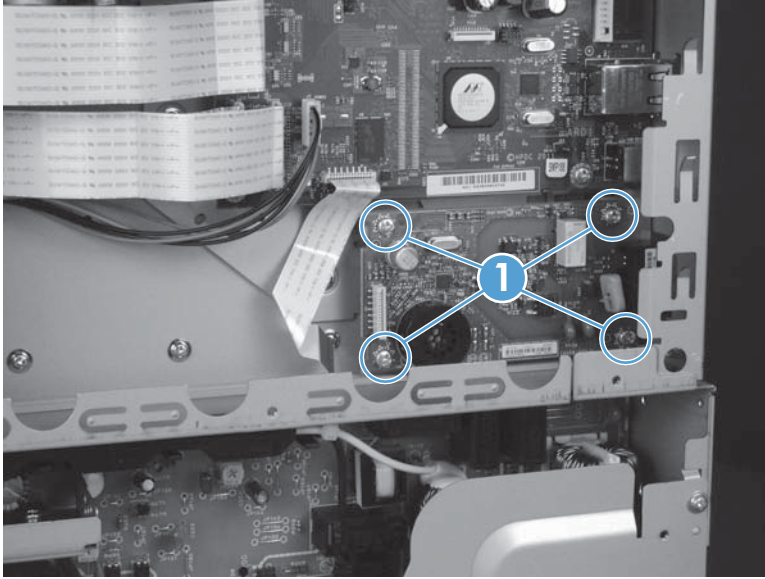

Wireless PCA

Before proceeding, remove the following components:

- Right-rear cover. See [Right-rear cover on page 48](#).
- Left cover. See [Left cover on page 50](#).
- Rear-upper cover. See [Rear-upper cover on page 53](#).
- Left-upper cover. See [Left-upper cover on page 54](#).
- Right-upper rear cover. See [Right-upper rear cover on page 55](#).
- Rear cover. See [Rear cover on page 56](#).
- Document feeder. See [Document feeder on page 73](#).
- Image scanner. See [Image scanner on page 77](#).

Remove the wireless PCA

Disconnect one connector (callout 1), remove one screw (callout 2), and then remove the PCA.

CAUTION: The wireless PCA wire-harness connector is keyed and must be correctly plugged into the PCA. Make sure that the connector is not reversed when connecting it to the PCA.

Figure 1-114 Remove the wireless PCA

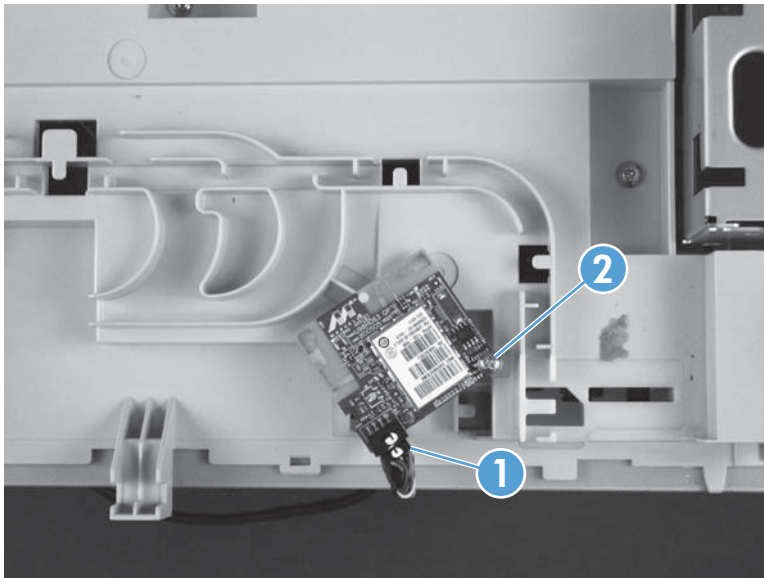

Interconnect board (ICB)

Before proceeding, remove the following components:

- Right-rear cover. See [Right-rear cover on page 48](#).
- Left cover. See [Left cover on page 50](#).
- Rear-upper cover. See [Rear-upper cover on page 53](#).
- Rear cover. See [Rear cover on page 56](#).

Remove the ICB



NOTE: To locate DC controller connector locations, see [DC controller PCA on page 7](#).

1. Disconnect two connectors (callout 1), one FFC (callout 2), and then remove one screw (callout 3).

Figure 1-115 Remove the ICB (1 of 4)

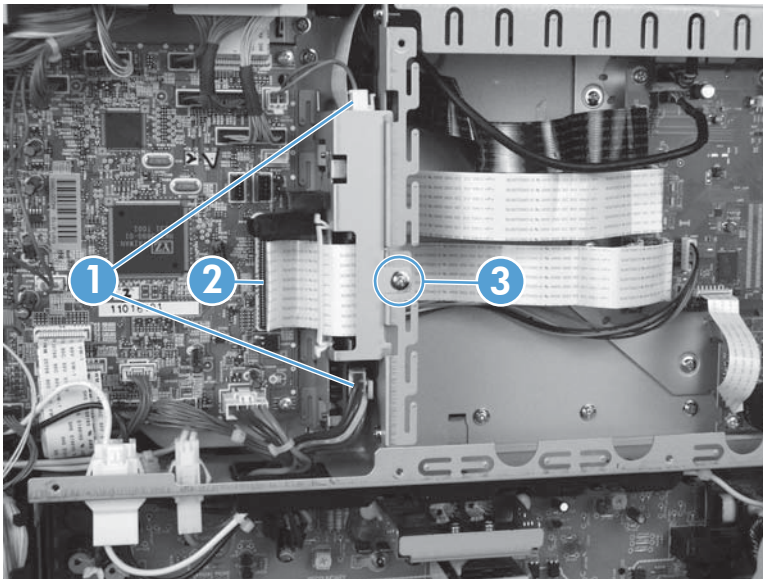

- Slide the ICB up to release it, and then rotate it away from the formatter cage.

CAUTION: The ICB is still attached to the product by two FFCs and one wire harness on the backside of the PCA. Do not attempt to completely remove the ICB.

Figure 1-116 Remove the ICB (2 of 4)

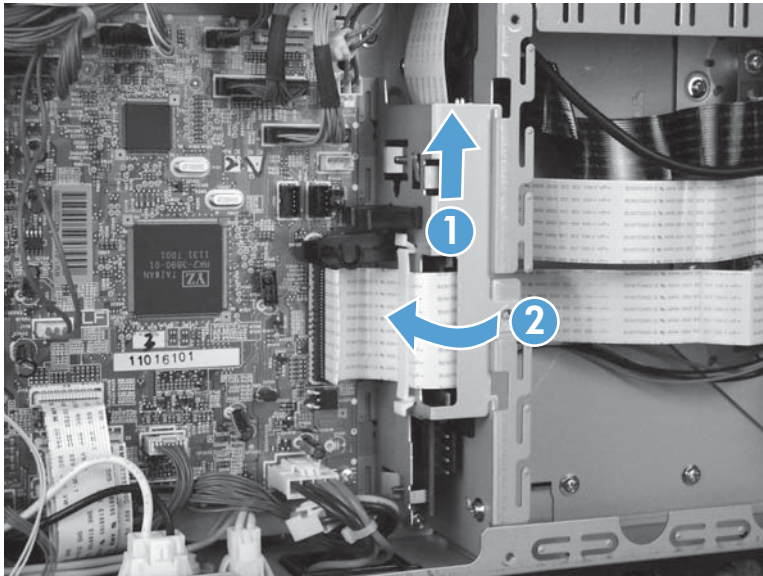

- Disconnect two FFCs (callout 1), and the disconnect one connector (callout 2).

Figure 1-117 Remove the ICB (3 of 4)

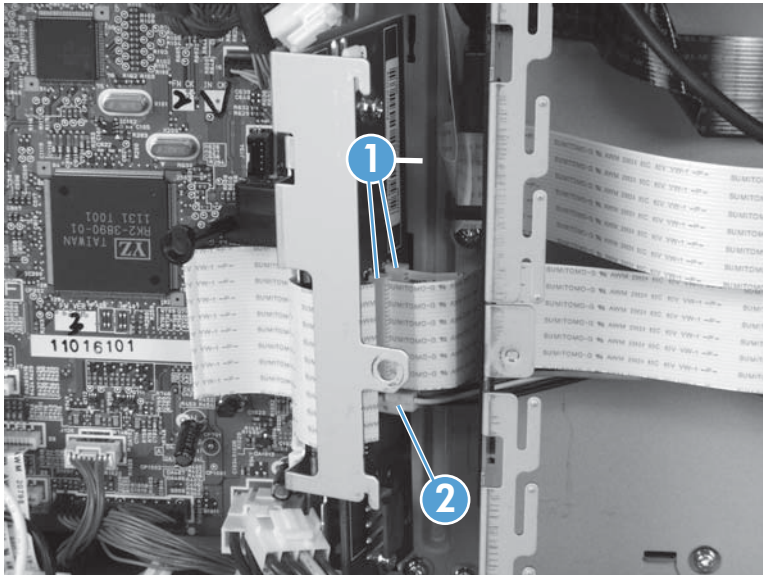

4. Remove the PCA.

Figure 1-118 Remove the ICB (4 of 4)

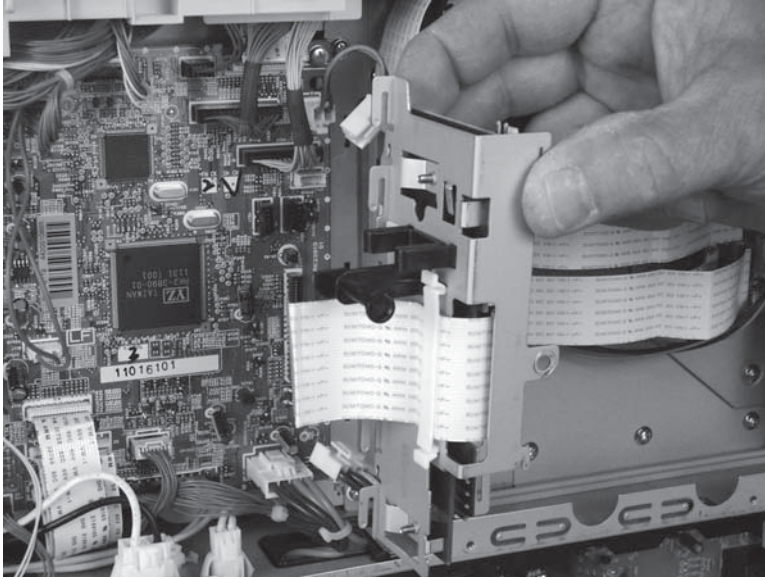

DC controller PCA and tray

Before proceeding, remove the following components:

- Toner-collection unit. See [Toner-collection unit on page 12](#).
- Right-rear cover. See [Right-rear cover on page 48](#).
- Left cover. See [Left cover on page 50](#).
- Rear-upper cover. See [Rear-upper cover on page 53](#).
- Rear cover. See [Rear cover on page 56](#).
- Formatter PCA. See [Formatter PCA on page 83](#).
- Interconnect board (ICB). See [Interconnect board \(ICB\) on page 88](#).

Remove the DC controller PCA and tray

 **CAUTION:**  ESD-sensitive part.

 **TIP:** To access components behind the DC controller PCA, remove the PCA and the sheet-metal tray together. Disconnect all of the connectors on the PCA, and then remove five screws and the bracket. See [Figure 1-119 Remove the DC controller PCA and tray \(1 of 4\) on page 91](#) and [Figure 1-122 Remove the DC controller PCA and tray \(4 of 4\) on page 93](#).

 **NOTE:** To locate DC controller connector locations, see [DC controller PCA on page 7](#).

1. Remove one screw (callout 1), and then remove the sheet-metal bracket (callout 2).

Figure 1-119 Remove the DC controller PCA and tray (1 of 4)

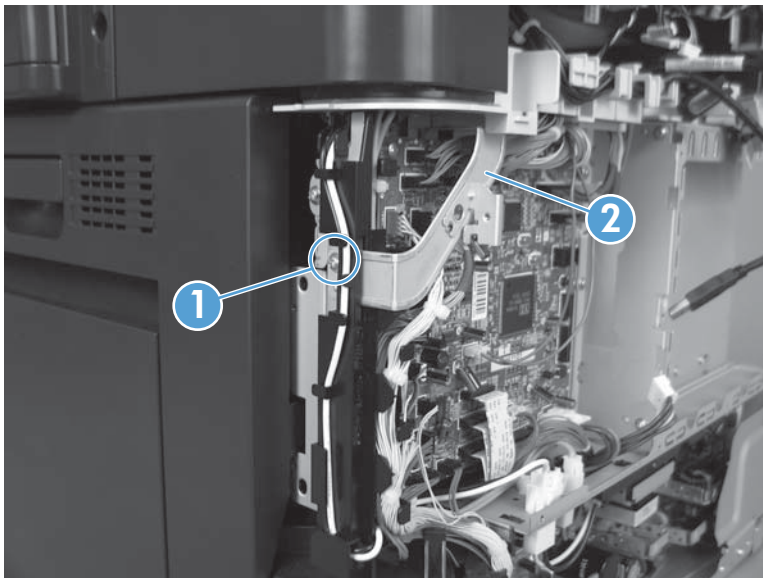

2. Disconnect all the connectors.

 **Reinstallation tip** The connector locations J133 and J134 are not used.

Figure 1-120 Remove the DC controller PCA and tray (2 of 4)

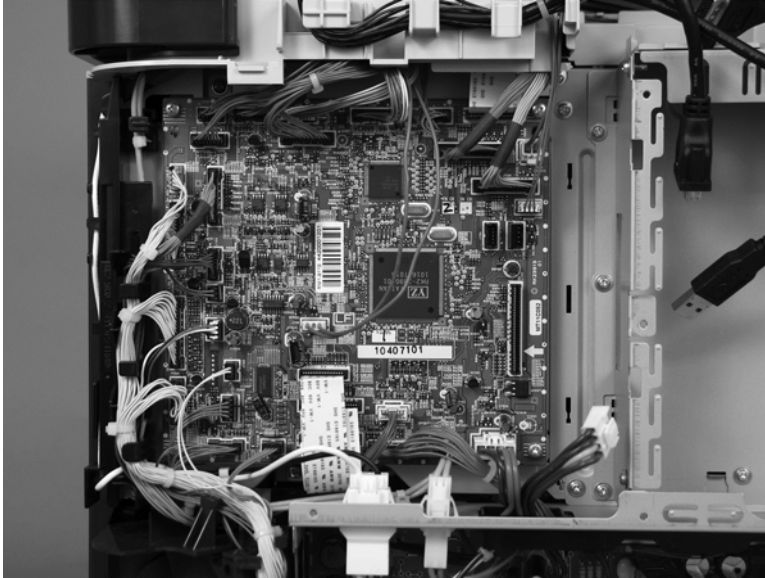

3. Remove four screws, and then remove the DC controller PCA.

 **NOTE:** If removing the PCA with the sheet metal tray, skip this step and go to step 4.

Figure 1-121 Remove the DC controller PCA and tray (3 of 4)



4. If necessary, remove three screws (callout 1) and the sheet metal tray.

 **NOTE:** Correctly install the cables in the cable guide (callout 2).

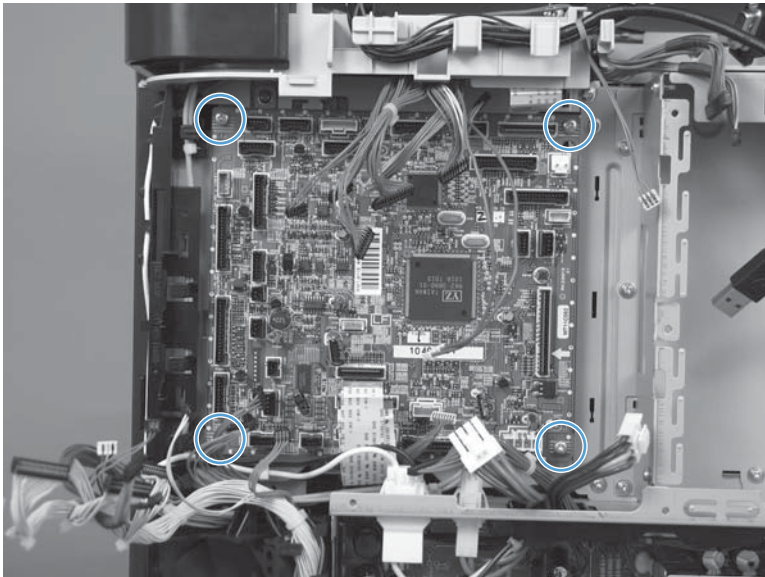
Figure 1-122 Remove the DC controller PCA and tray (4 of 4)



Low-voltage power supply (LVPS)

Before proceeding, remove the following components:

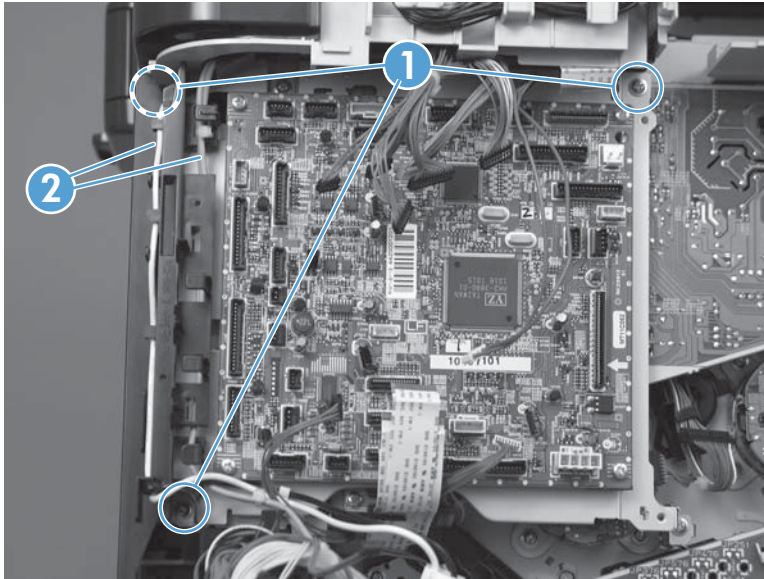
- Toner-collection unit. See [Toner-collection unit on page 12](#).
- Right-rear cover. See [Right-rear cover on page 48](#).
- Left cover. See [Left cover on page 50](#).
- Rear-upper cover. See [Rear-upper cover on page 53](#).
- Rear cover. See [Rear cover on page 56](#).
- Formatter PCA. See [Formatter PCA on page 83](#).
- Interconnect board (ICB). See [Interconnect board \(ICB\) on page 88](#).

Remove the LVPS

 **CAUTION:**  ESD-sensitive part.

 **NOTE:** The formatter cage is attached to the LVPS. Both components are removed as an assembly, and then the formatter cage is removed from the LVPS.

1. Disconnect six connectors (callout 1; J100, J101, J143 on the DC controller PCA).

 **NOTE:** To locate DC controller connector locations, see [DC controller PCA on page 7](#).

Figure 1-123 Remove the LVPS (1 of 8)



2. Push in on the locking tab to release the retainer (callout 2), and then separate the retainer from the assembly.

 **NOTE:** The retainer remains attached to the wire harness and is disengaged from the assembly.

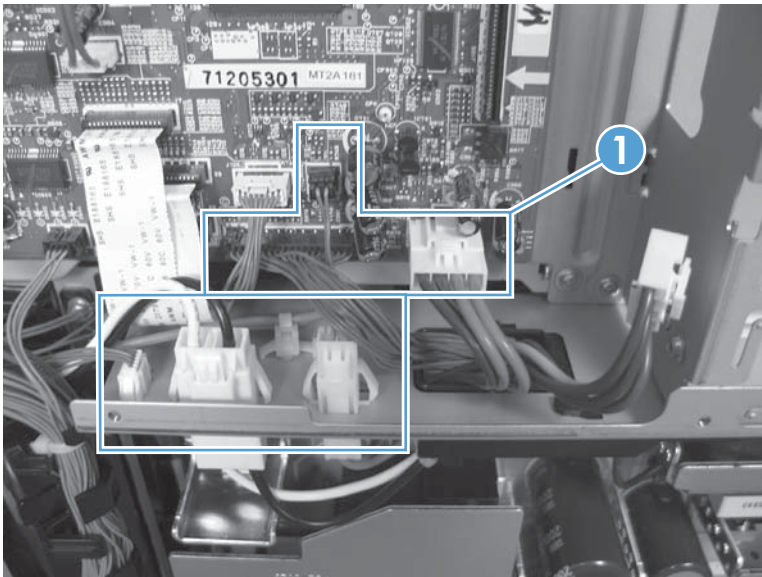
Figure 1-124 Remove the LVPS (2 of 8)



3. Remove three screws (callout 3), and then remove the handle (callout 4).

Figure 1-125 Remove the LVPS (3 of 8)

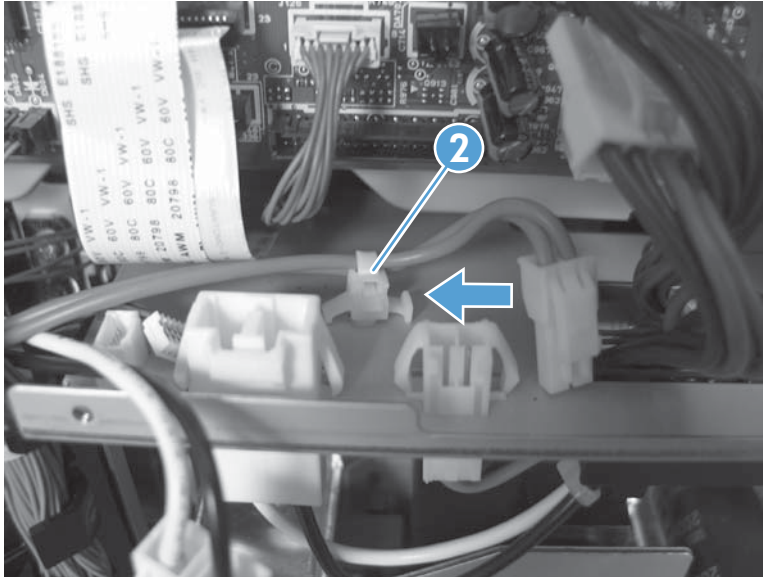
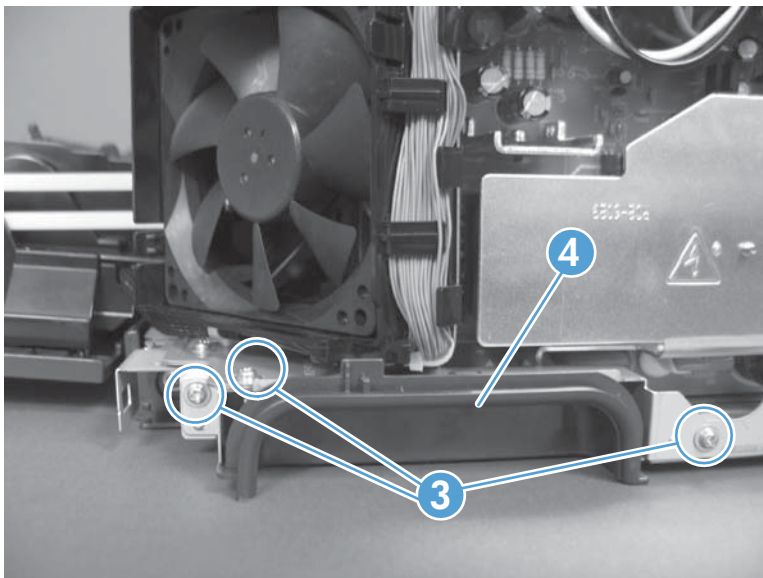

4. Remove five screws.

 **NOTE:** The illustration below shows the ICB removed.

Figure 1-126 Remove the LVPS (4 of 8)



5. Remove two screws.

Figure 1-127 Remove the LVPS (5 of 8)

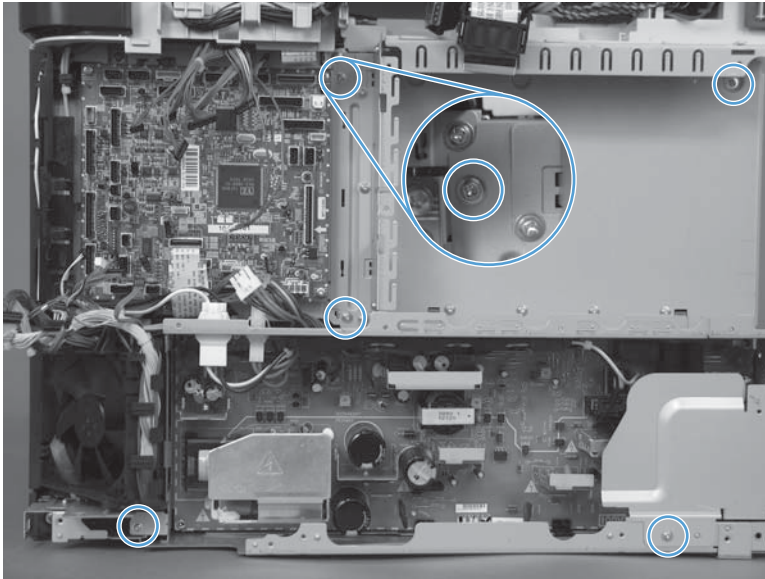
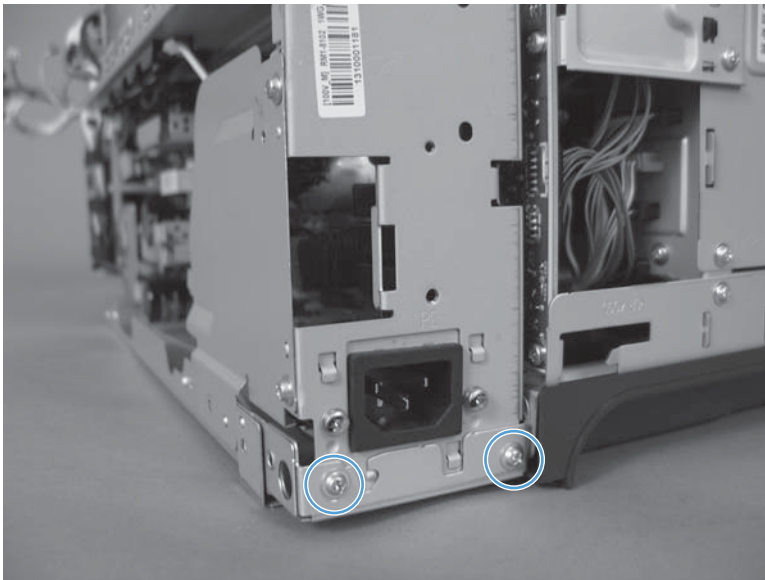

6. Rotate the formatter cage away from the top of the product.

Figure 1-128 Remove the LVPS (6 of 8)

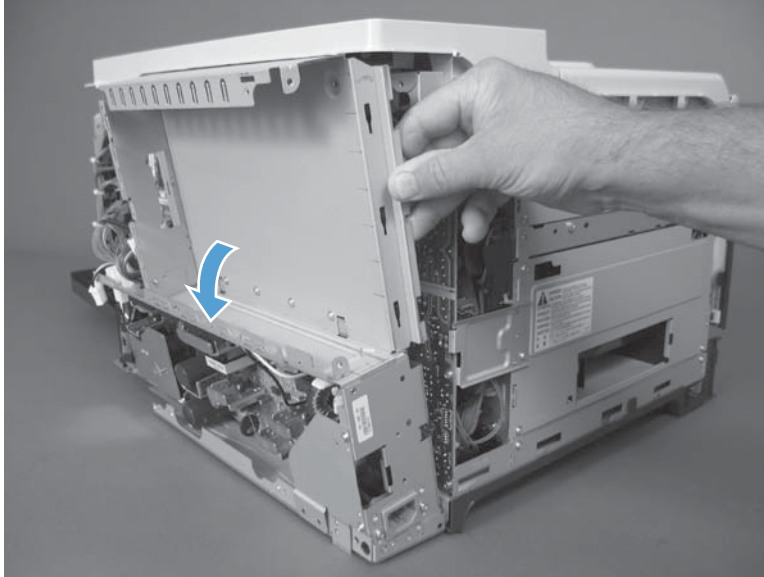

7. Remove the assembly.

Figure 1-129 Remove the LVPS (7 of 8)

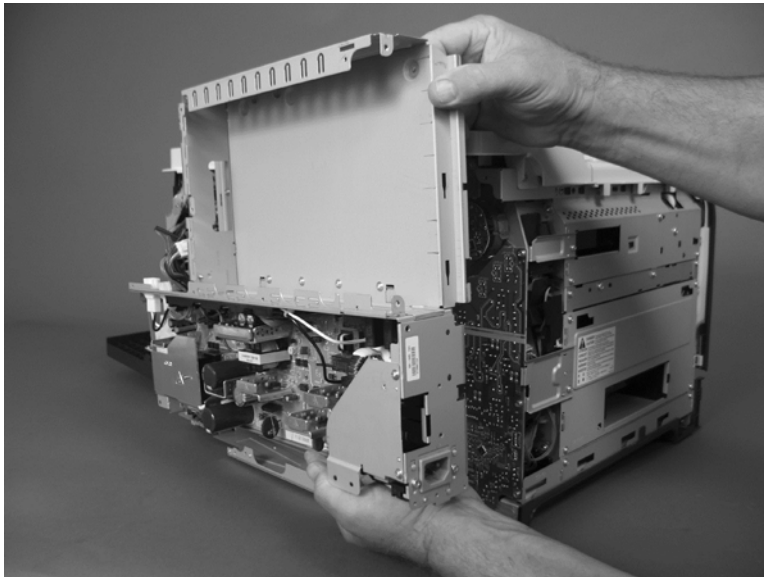

8. Remove four screws (callout 9), and then separate the formatter cage from the low-voltage power supply.

Figure 1-130 Remove the LVPS (8 of 8)

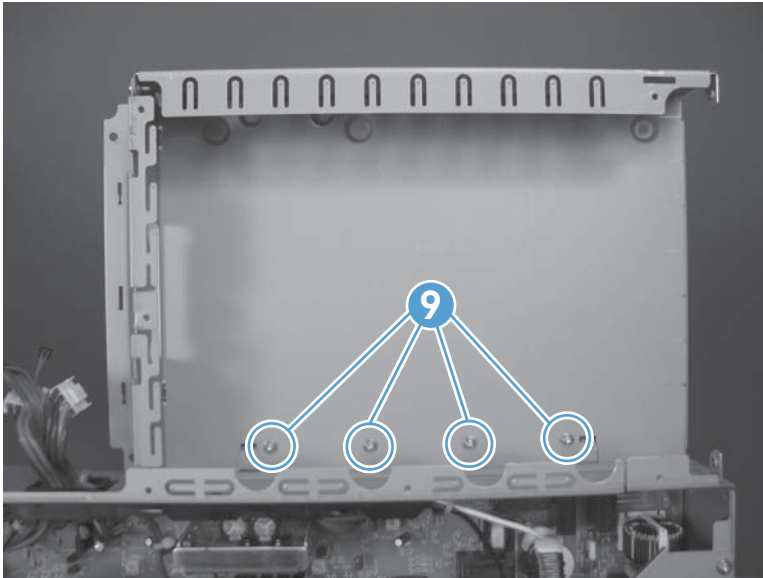

Delivery fan, cartridge fan, and environmental sensor

Before proceeding, remove the following components:

- Toner-collection unit. See [Toner-collection unit on page 12](#).
- Left cover. See [Left cover on page 50](#).

Remove the delivery fan, cartridge fan, and environmental sensor

1. Remove five screws (callout 1), and then remove the sheet-metal plate (callout 2).

 **NOTE:** Release the small sheet-metal plate (callout 3) to allow access to the larger sheet-metal plate behind it. Leave the smaller plate attached to the chassis.

Figure 1-131 Remove the delivery fan, cartridge fan, and environmental sensor (1 of 9)



2. Disconnect five connectors (callout 3).

 **NOTE:** Disconnect the larger connector on the right side, from the bottom. Disconnect the two smaller connectors on the right side, from the top.

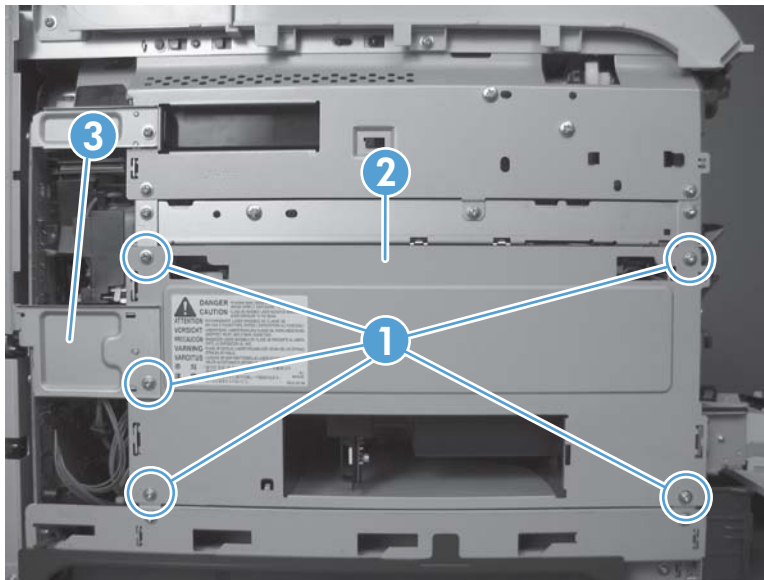
Figure 1-132 Remove the delivery fan, cartridge fan, and environmental sensor (2 of 9)



3. Release two tabs (callout 4), and then slide the delivery-fan and cartridge-fan assembly toward the power-supply side of the product to release it.

Figure 1-133 Remove the delivery fan, cartridge fan, and environmental sensor (3 of 9)

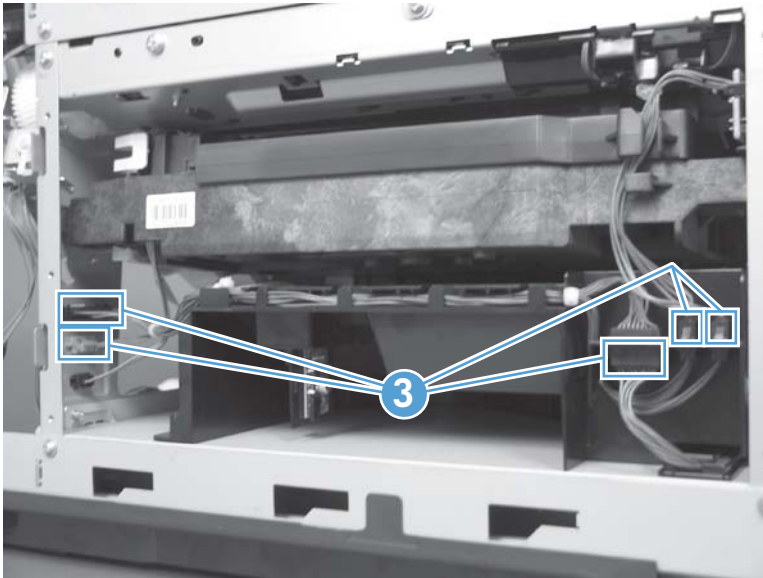
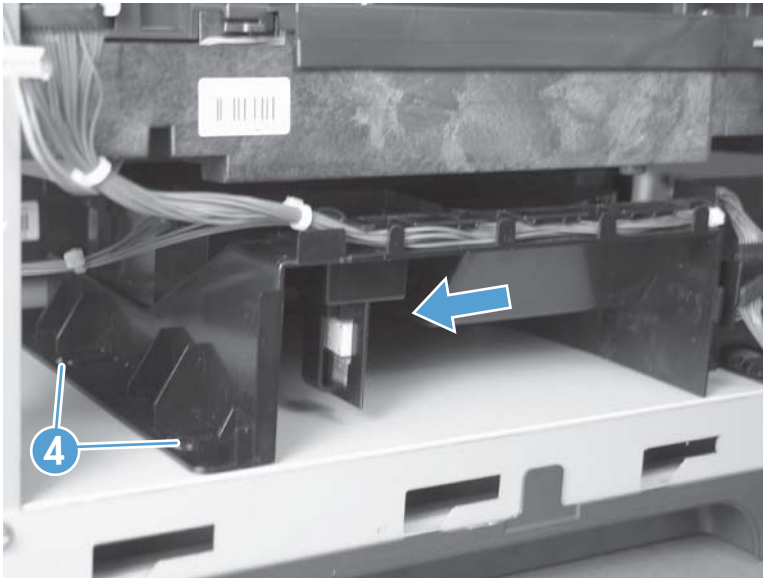

4. Pull the assembly slightly out of the product, disconnect two connectors (callout 5), and then remove the assembly.

Figure 1-134 Remove the delivery fan, cartridge fan, and environmental sensor (4 of 9)

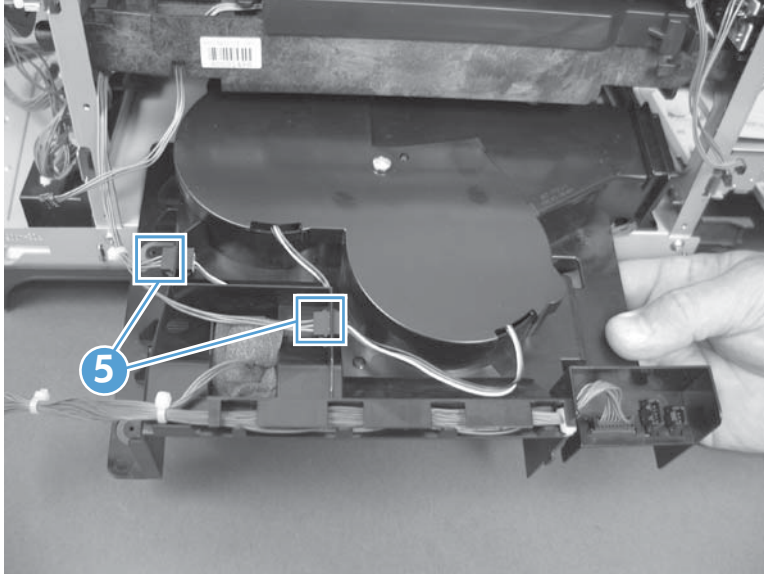

5. Remove one screw (callout 6), and then remove the cover (callout 7).

Figure 1-135 Remove the delivery fan, cartridge fan, and environmental sensor (5 of 9)

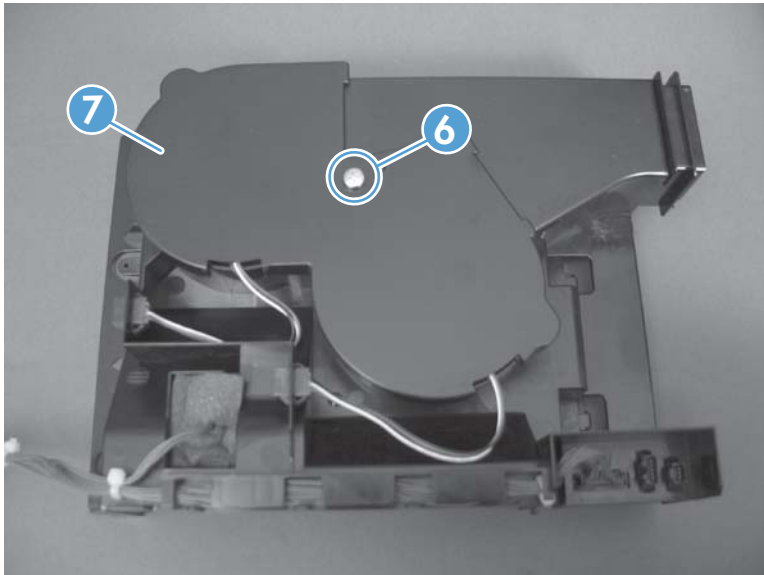

6. Disconnect two connectors (callout 8), and then remove the fans (callout 9).

Figure 1-136 Remove the delivery fan, cartridge fan, and environmental sensor (6 of 9)

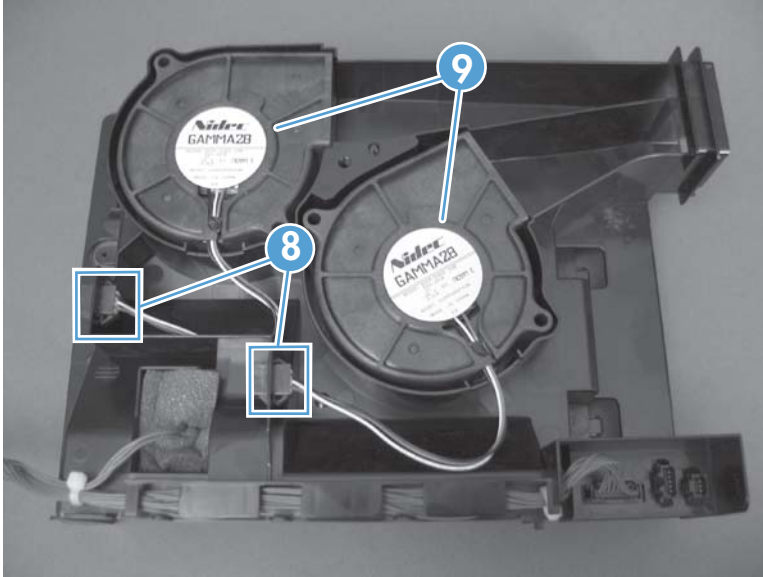

7. Remove the antistatic foam (callout 10).

Figure 1-137 Remove the delivery fan, cartridge fan, and environmental sensor (7 of 9)

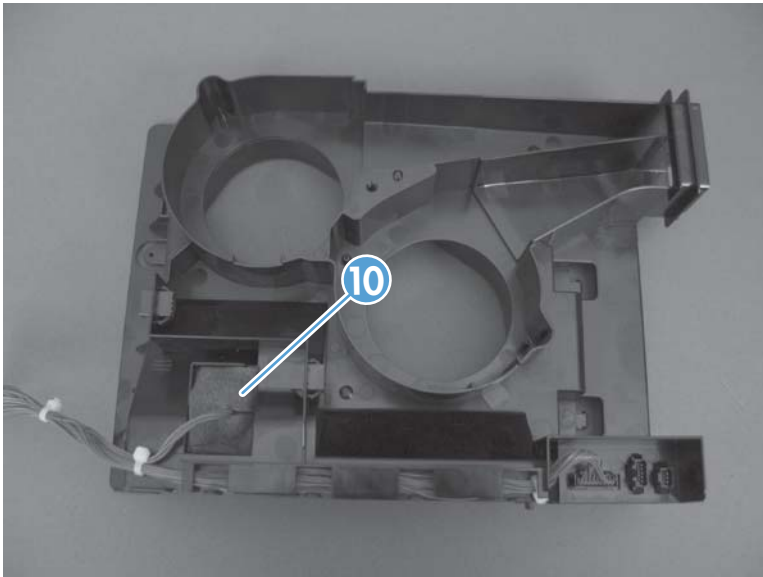

8. Release one tab (callout 11).

Figure 1-138 Remove the delivery fan, cartridge fan, and environmental sensor (8 of 9)

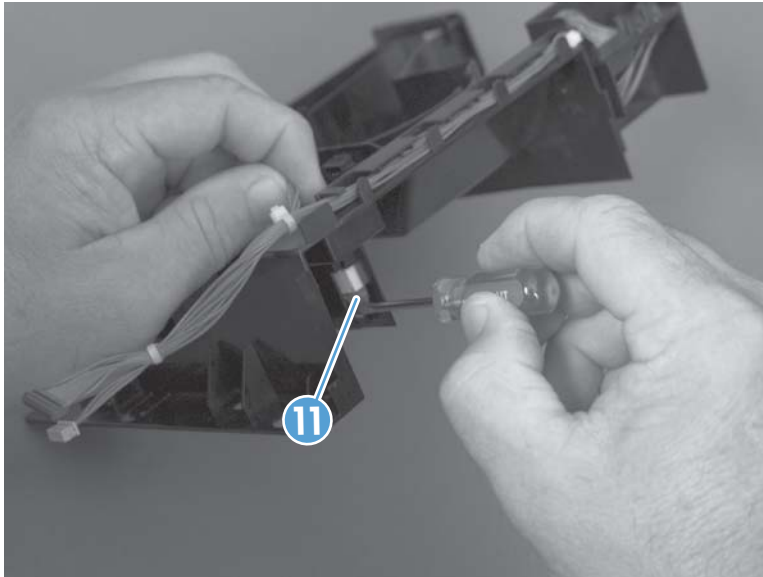

9. Disconnect one connector (callout 12), and then remove the environmental sensor.

CAUTION:  ESD-sensitive part.

Figure 1-139 Remove the delivery fan, cartridge fan, and environmental sensor (9 of 9)

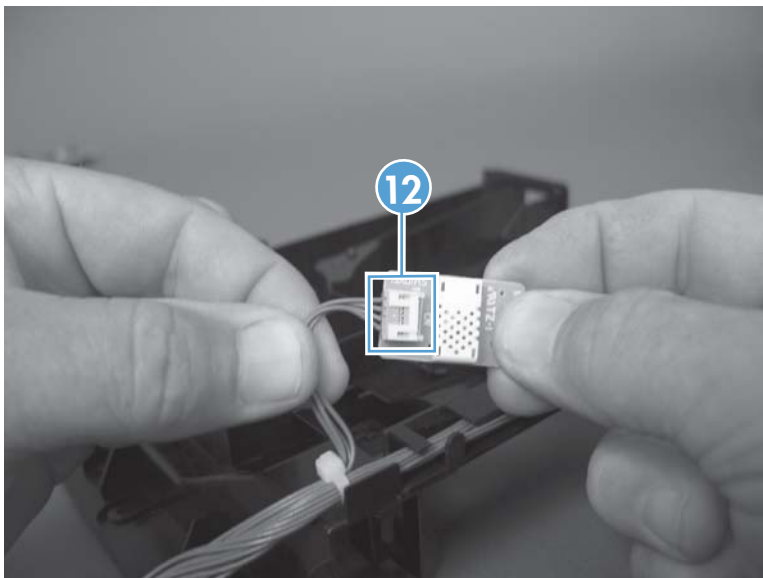

Toner-collection sensor

Before proceeding, remove the following components:

- Toner-collection unit. See [Toner-collection unit on page 12](#).
- Left cover. See [Left cover on page 50](#).

Remove the toner-collection sensor

1. Remove five screws (callout 1), and then remove the sheet-metal plate (callout 2).

 **NOTE:** Release the small sheet-metal plate (callout 3) to allow access to the larger sheet-metal plate behind it. Leave the smaller plate attached to the chassis.

Figure 1-140 Remove the toner-collection sensor (1 of 4)



2. Disconnect one connector (callout 3).

Figure 1-141 Remove the toner-collection sensor (2 of 4)

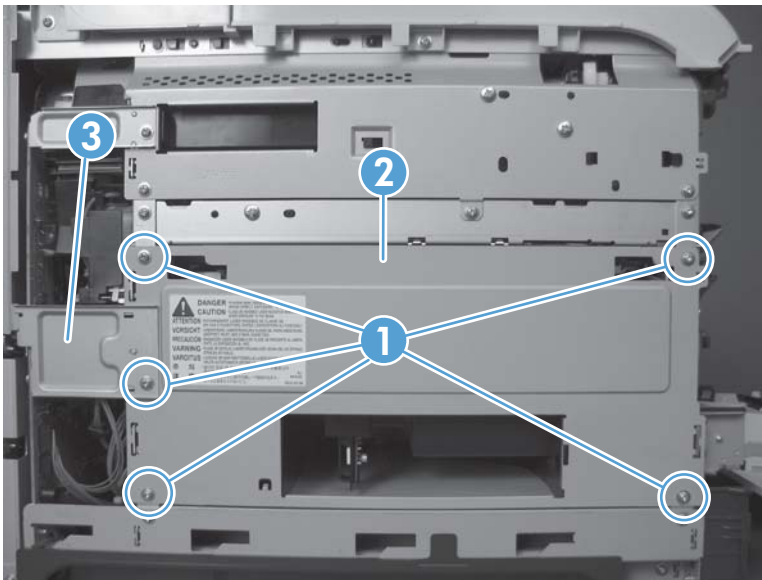
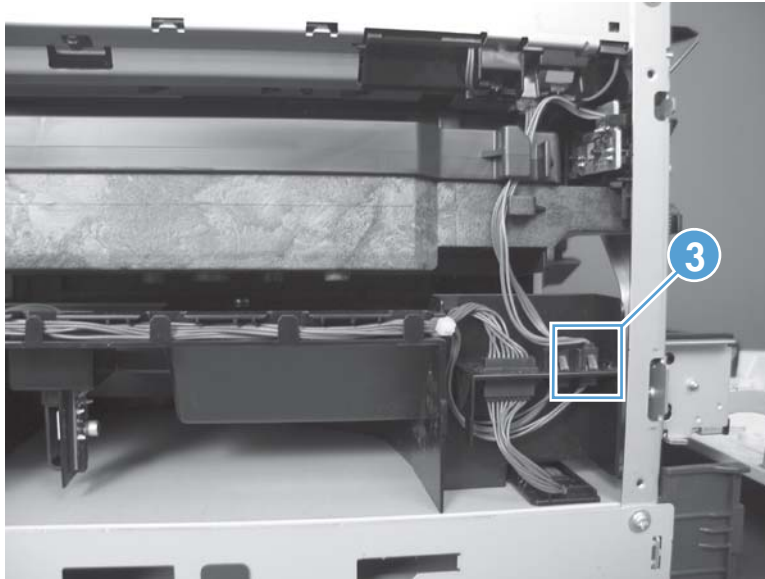

3. Remove one screw (callout 4).

 **Reinstallation tip** When you reinstall the sensor, make sure that the tab (callout 5) on the sensor body completely engages the slot in the product chassis.

Figure 1-142 Remove the toner-collection sensor (3 of 4)



4. Remove the toner-collection sensor.

Figure 1-143 Remove the toner-collection sensor (4 of 4)

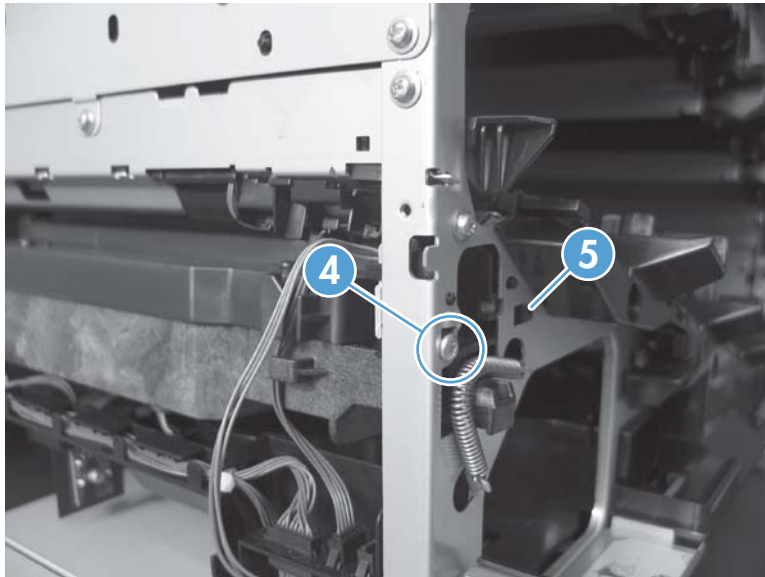
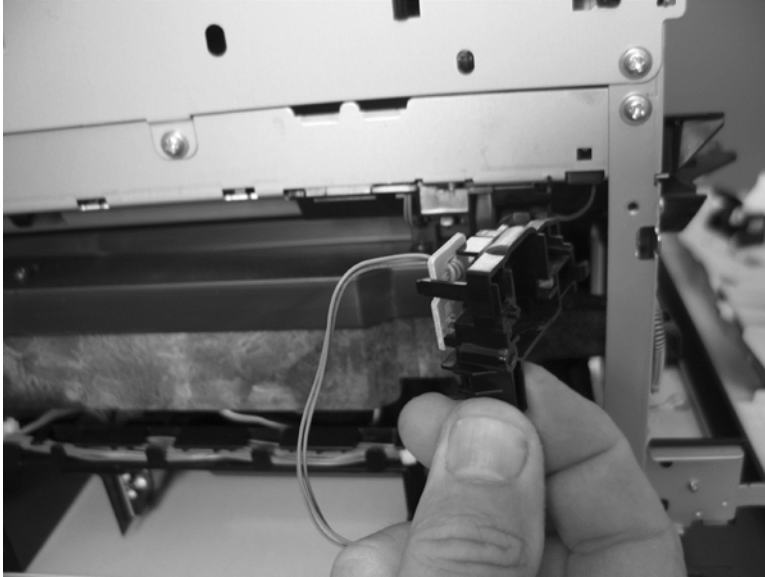

Residual-toner-feed motor

Before proceeding, remove the following components:

- Toner-collection unit. See [Toner-collection unit on page 12](#).
- Intermediate transfer belt (ITB). See [Intermediate transfer belt \(ITB\) on page 24](#).
- Left cover. See [Left cover on page 50](#).

Remove the residual-toner-feed motor

 **NOTE:** Be careful. Do not dislodge the residual-toner collection door when you remove the assembly. If the door becomes dislodged, see [Reinstall the residual-toner collection door on page 111](#) to reinstall it.

1. Release one tab (callout 1) while you support the cover (callout 2).

Figure 1-144 Remove the residual-toner-feed motor (1 of 7)

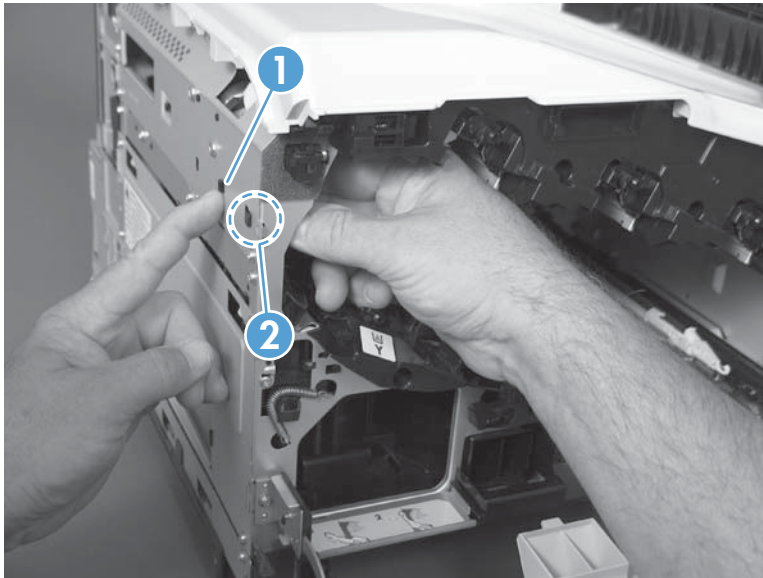

2. Remove the cover.

Figure 1-145 Remove the residual-toner-feed motor (2 of 7)



3. Disconnect one connector (callout 3).

Figure 1-146 Remove the residual-toner-feed motor (3 of 7)

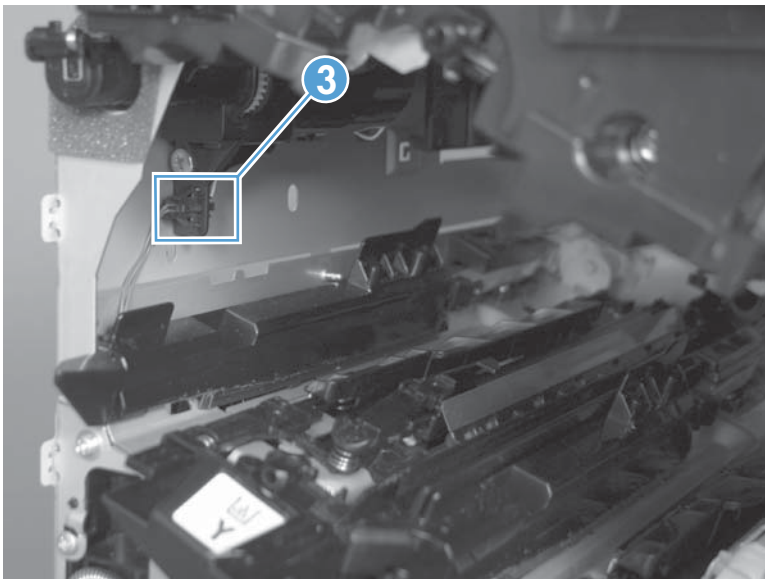

4. Support the assembly, and then remove two screws (callout 4).

Figure 1-147 Remove the residual-toner-feed motor (4 of 7)

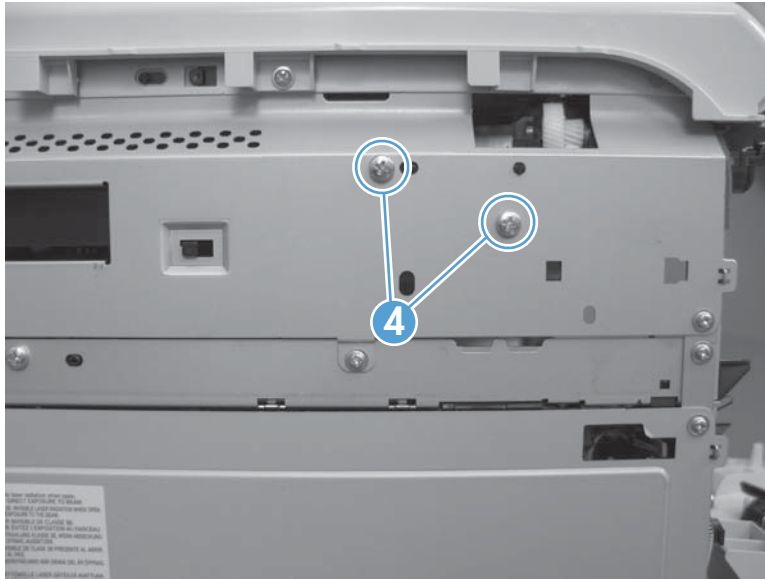

5. Be careful. Do not dislodge the residual-toner collection door when you remove the assembly. If the door becomes dislodged, see [Reinstall the residual-toner collection door on page 111](#) to reinstall it.

Figure 1-148 Remove the residual-toner-feed motor (5 of 7)

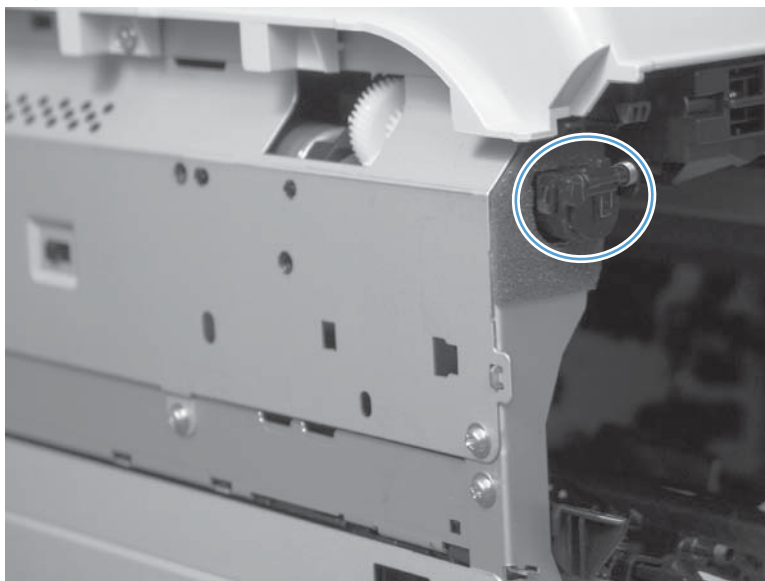

6. Push the assembly into the product to release it.

Figure 1-149 Remove the residual-toner-feed motor (6 of 7)

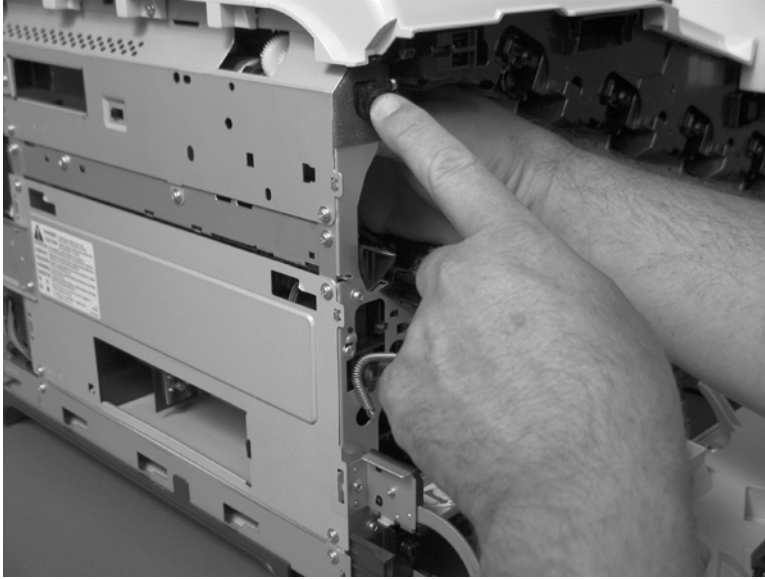

7. Remove the motor.

Figure 1-150 Remove the residual-toner-feed motor (7 of 7)

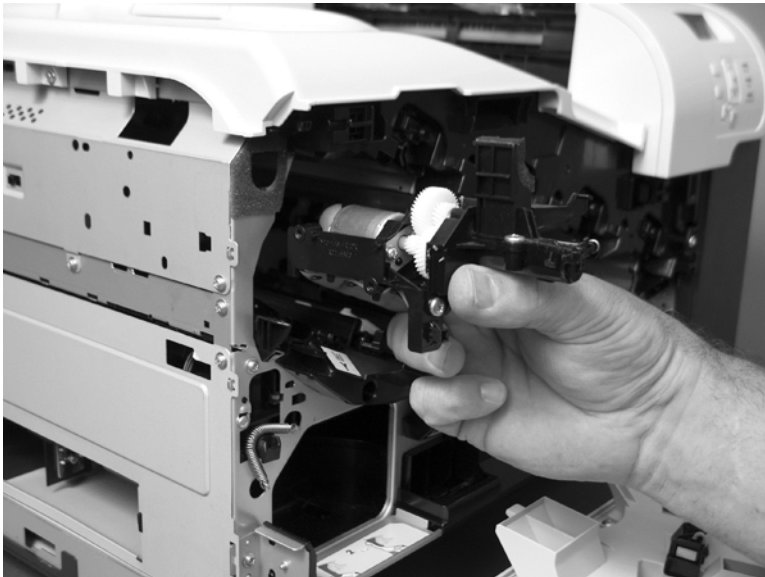

Reinstall the residual-toner collection door

Snap the residual-toner collection door into the holders on the assembly. Make sure that the spring is correctly installed.

Figure 1-151 Reinstall the residual-toner collection door



Secondary transfer assembly

The secondary transfer assembly includes the transfer roller.

1. Open the right-door assembly.
2. Use the blue lever (callout 1) to lower the secondary transfer assembly.

Figure 1-152 Remove the secondary transfer assembly (1 of 3)

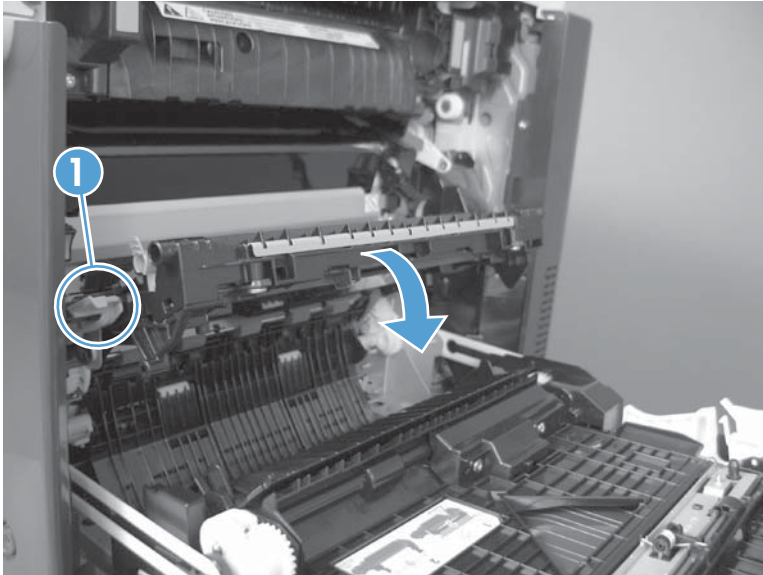

3. Release one tab and carefully remove the stopper.

 **NOTE:** You might have to slightly lift up on the corner of the assembly to release the stopper pin from the hole in the chassis.

Figure 1-153 Remove the secondary transfer assembly (2 of 3)



4. Remove the secondary transfer assembly.

Figure 1-154 Remove the secondary transfer assembly (3 of 3)

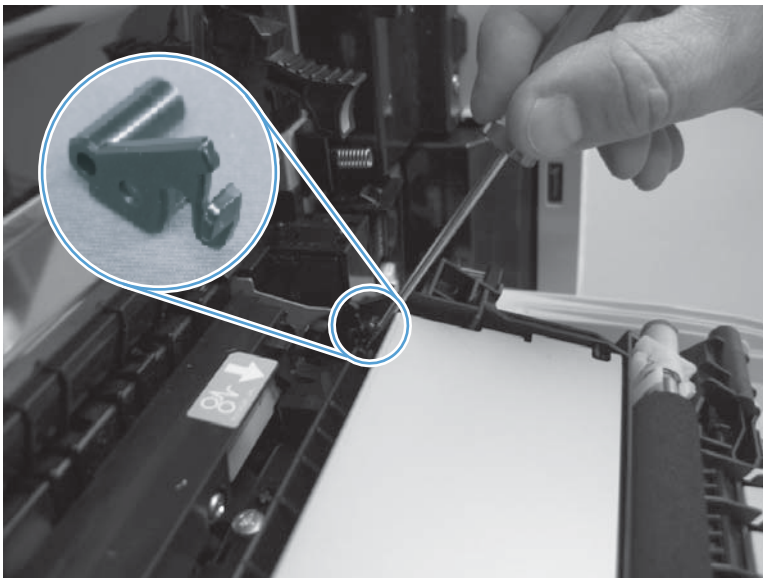

Reinstall the secondary transfer assembly

Press and hold down the blue release lever when you reinstall the assembly.

Figure 1-155 Reinstall the secondary transfer assembly

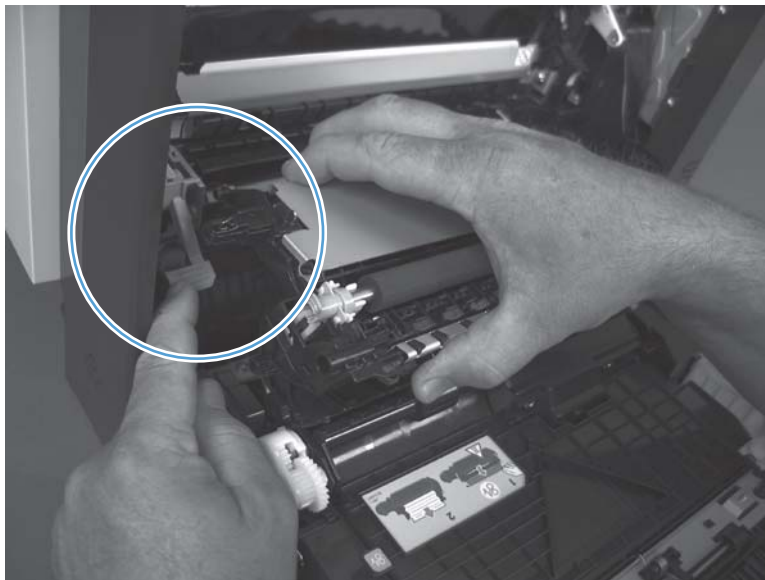

Lower pickup guide

Remove the lower pickup guide

1. Open the right-door assembly.
2. Locate the lower pickup guide directly below the registration assembly. The guide is locked into place by two green circular knobs (callout 1).

Figure 1-156 Remove the lower pickup guide (1 of 4)

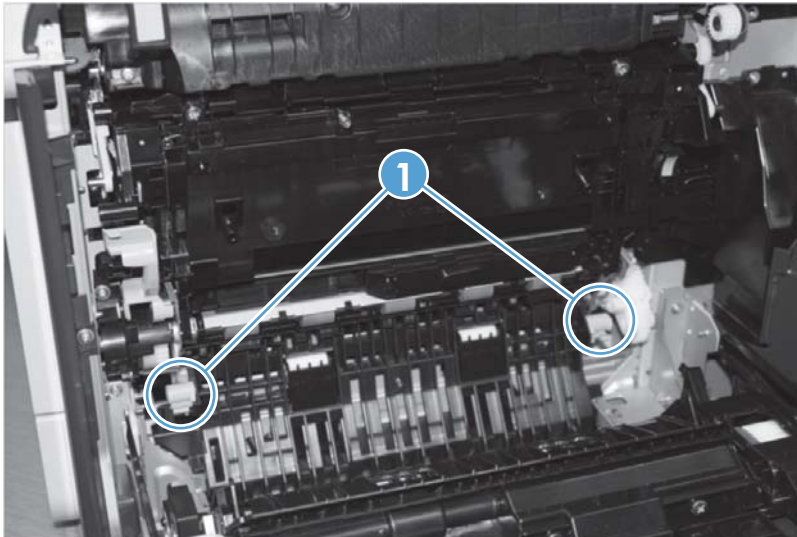

3. Lift the green circular knobs simultaneously to release the assembly.

Figure 1-157 Remove the lower pickup guide (2 of 4)

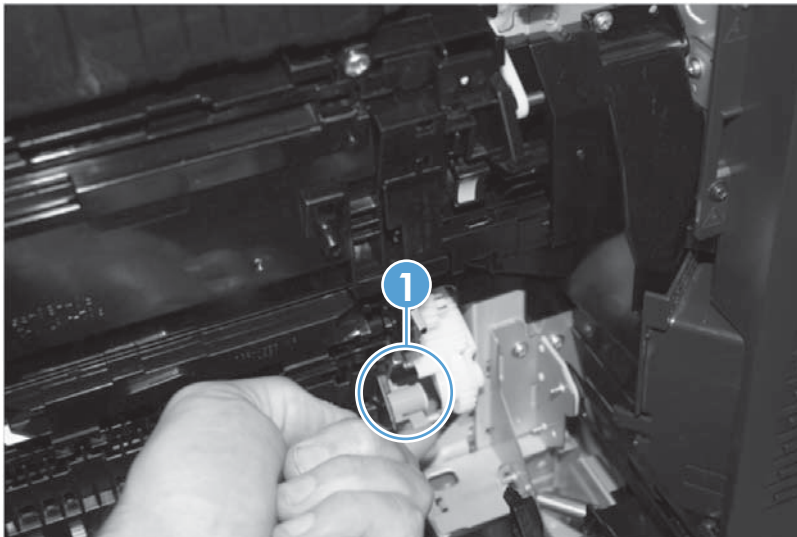

4. Raise the guide, and then loosen, but do not remove, one screw (callout 1) on the paper entrance guide.

Figure 1-158 Remove the lower pickup guide (3 of 4)

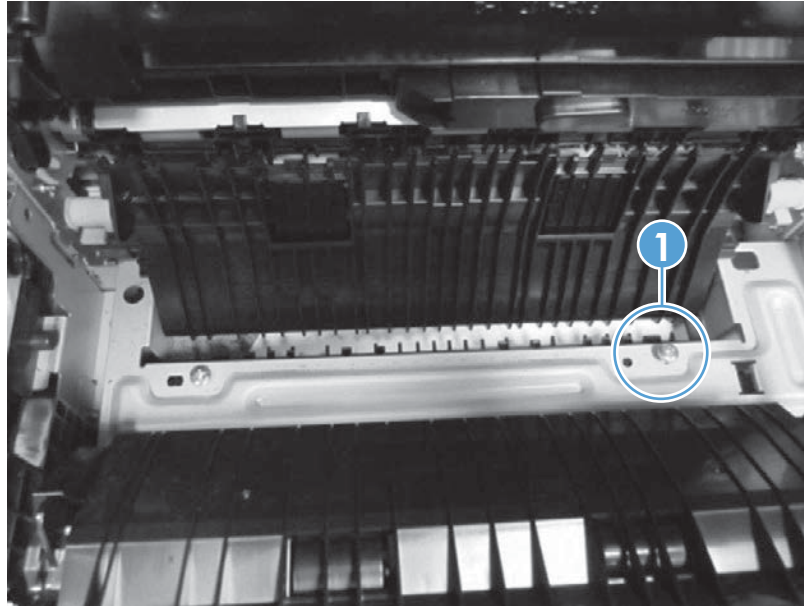

5. While pushing down on the paper entrance guide (callout 1), use a flat blade screwdriver to press in on the hinge pin (callout 2) and release it from the product. Rotate the assembly counterclockwise away from the product to remove it.

Figure 1-159 Remove the lower pickup guide (4 of 4)

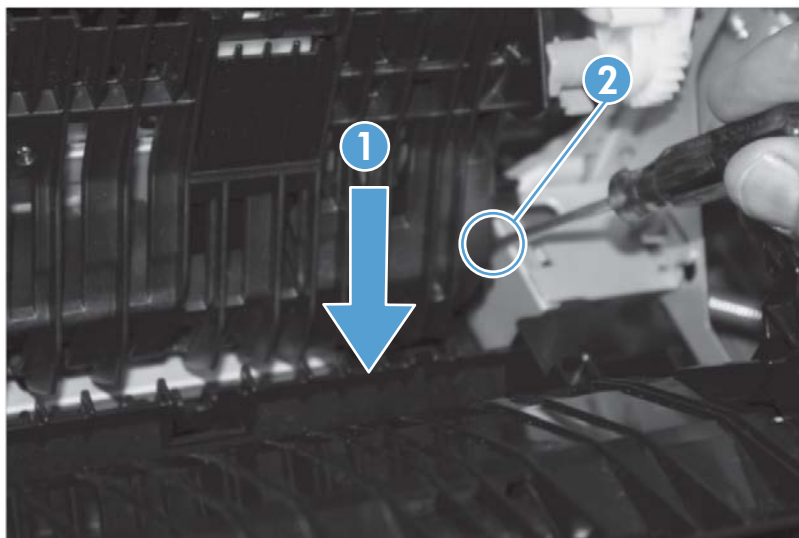

Reinstall the lower pickup guide

- ▲ Insert the front pin of the assembly into the hole at the front of the chassis. Slightly press down on the rear hinge pin and insert it into the hole at the rear of the chassis. Rotate the guide toward the product until the green knobs snap back into place. Tighten the screw on the paper entrance guide.

Registration density (RD) sensor assembly

Before proceeding, remove the following components:

- Intermediate transfer belt (ITB). See [Intermediate transfer belt \(ITB\) on page 24](#).
- Secondary transfer assembly. See [Secondary transfer assembly on page 112](#).

Remove the RD sensor assembly

1. Remove two screws (callout 1).

Figure 1-160 Remove the RD sensor assembly (1 of 6)

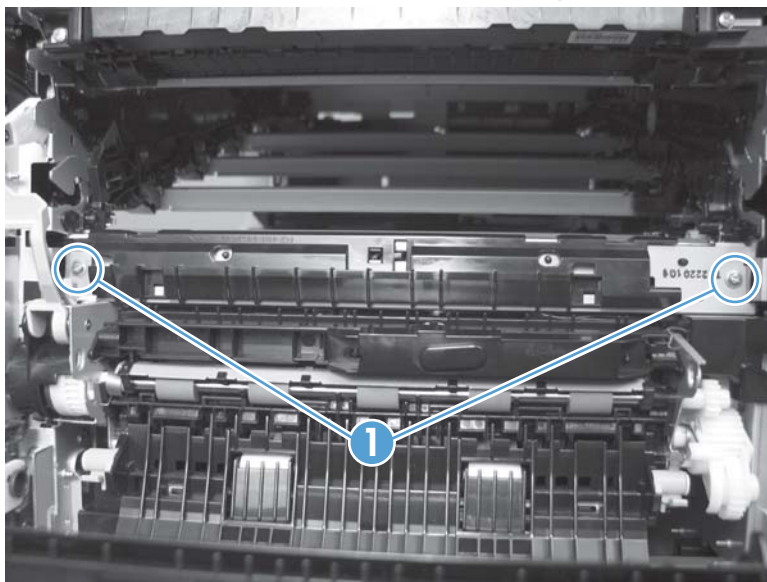

2. Slide the shutter toward the right side of the product. Keep the shutter in this position for the following step.

Figure 1-161 Remove the RD sensor assembly (2 of 6)

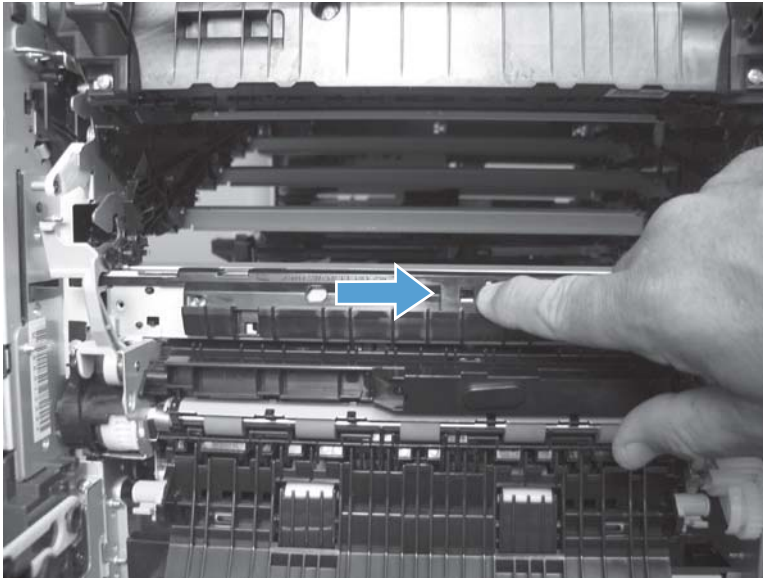

3. Carefully separate the assembly from the product. The assembly wire harnesses are still attached to the product.

CAUTION: Do not damage the shutter as it passes through the chassis.

Figure 1-162 Remove the RD sensor assembly (3 of 6)

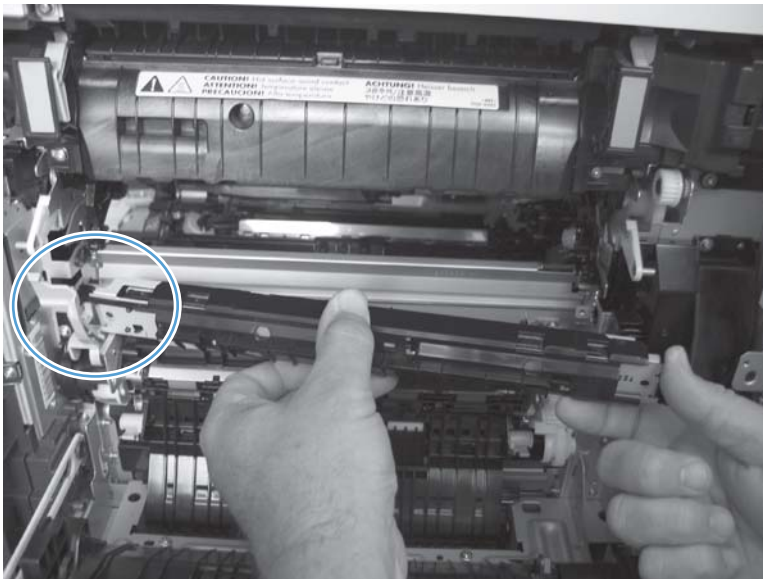

4. Disconnect two connectors (callout 2) on the back side of the assembly.

Figure 1-163 Remove the RD sensor assembly (4 of 6)

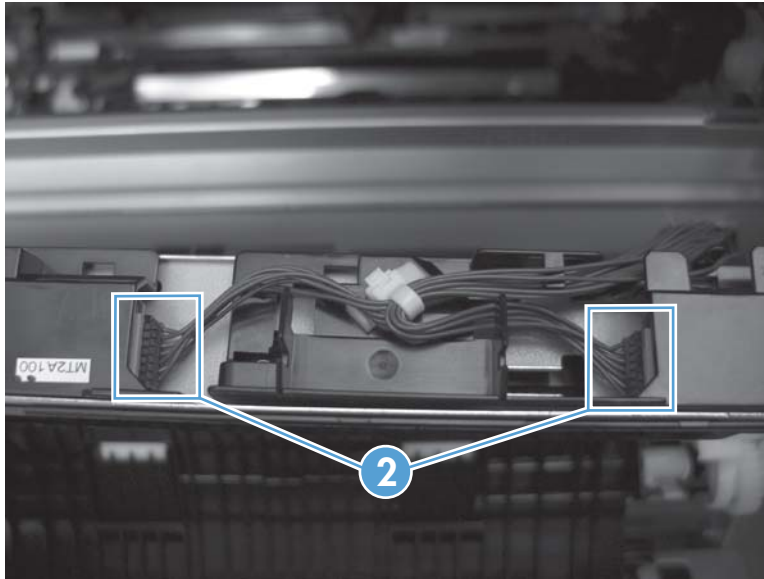

5. Push in on the locking tab to release the retainer (callout 3), and then separate the retainer from the assembly.



NOTE: The retainer remains attached to the wire harness and disengages from the assembly.

Figure 1-164 Remove the RD sensor assembly (5 of 6)

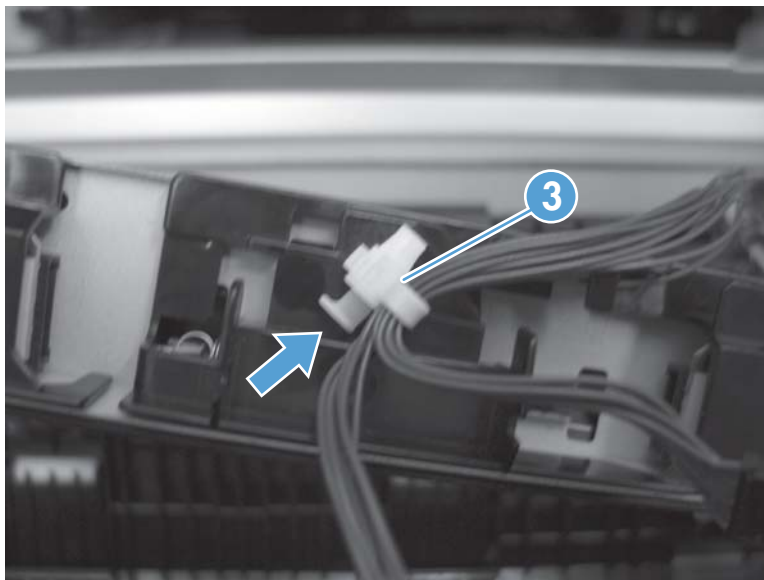

6. Remove the assembly.

Figure 1-165 Remove the RD sensor assembly (6 of 6)

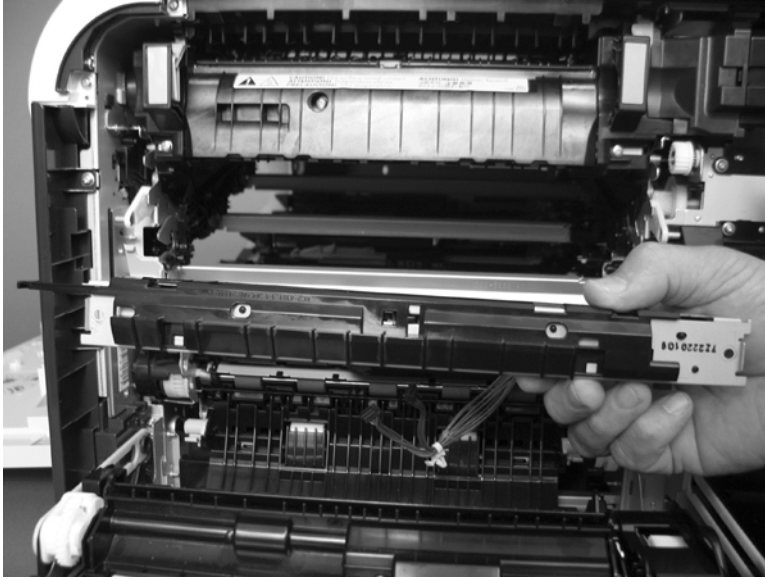

Power-supply fan and fan duct

Before proceeding, remove the following components:

- Toner-collection unit. See [Toner-collection unit on page 12](#).
- Right-rear cover. See [Right-rear cover on page 48](#).
- Left cover. See [Left cover on page 50](#).
- Rear-upper cover. See [Rear-upper cover on page 53](#).
- Rear cover. See [Rear cover on page 56](#).

Remove the power-supply fan and fan duct

1. Disconnect one connector (callout 1; J119), and release the wire harnesses from the guide (callout 2).

 **NOTE:** To locate DC controller connector locations, see [DC controller PCA on page 7](#).

Figure 1-166 Remove the power-supply fan (1 of 4)

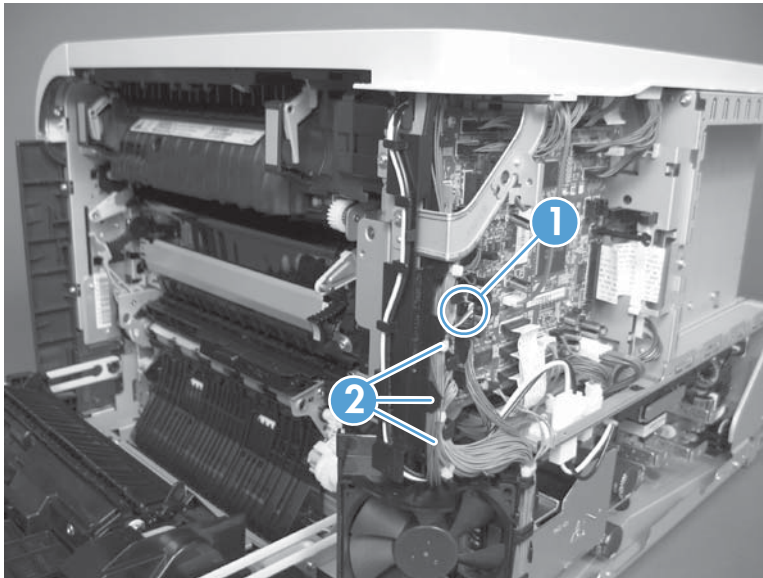

- 2. To remove the fan only:** Release two tabs (callout 3), and then remove the fan from the fan duct.

 **Reinstallation tip** When the fan is reinstalled, the air must flow into the product. Look at the arrows embossed on the fan frame that indicate air flow direction.

Figure 1-167 Remove the power-supply fan (2 of 4)



- 3. To remove the fan and the fan duct:** Remove one screw (callout 4), and then release the wire harnesses from the guides on the fan duct.

Figure 1-168 Remove the power-supply fan (3 of 4)

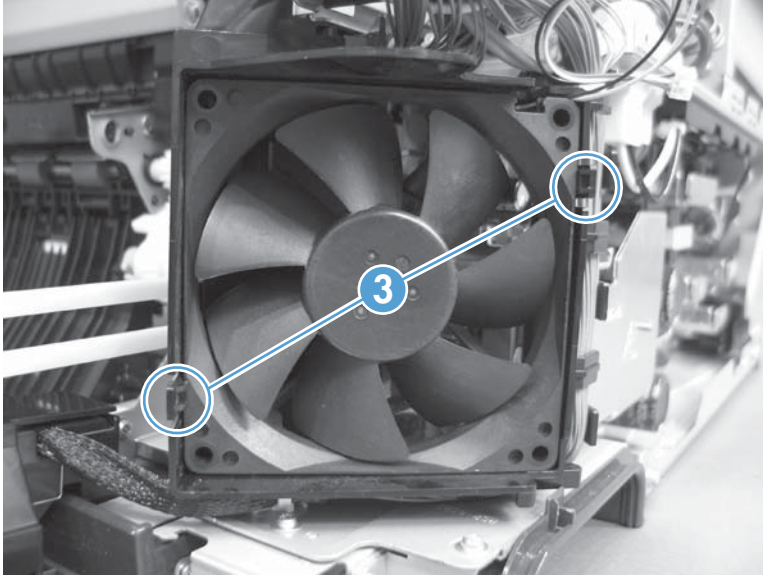
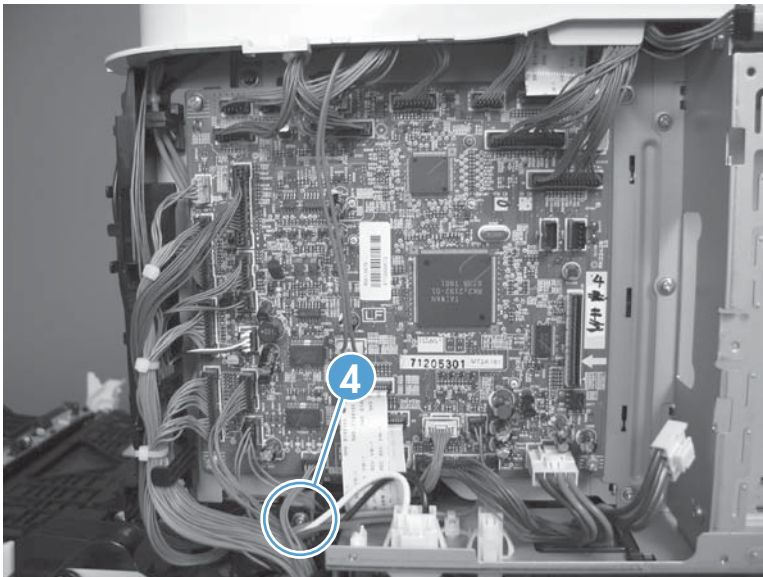

- 4. To remove the fan and the fan duct:** Release one tab (callout 5), and then remove the fan and the fan duct (callout 6).

Figure 1-169 Remove the power-supply fan (4 of 4)

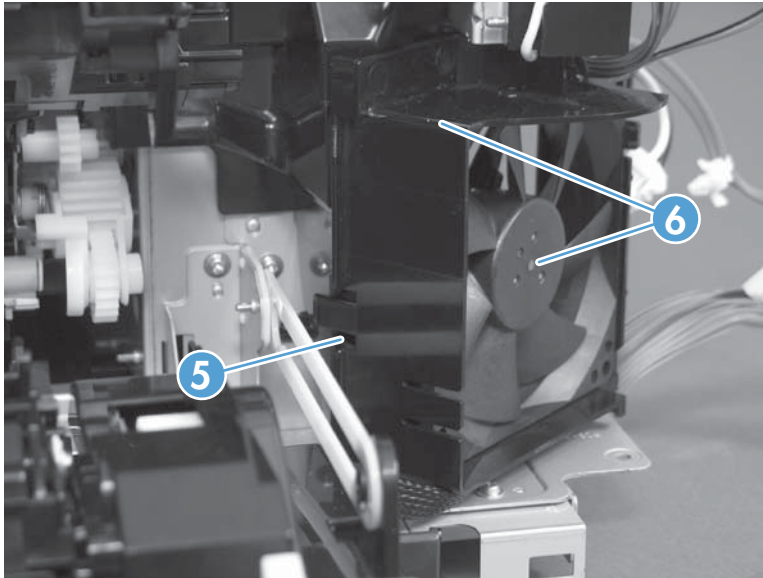

Registration assembly

Before proceeding, remove the following components:

- Toner-collection unit. See [Toner-collection unit on page 12](#).
- Intermediate transfer belt (ITB). See [Intermediate transfer belt \(ITB\) on page 24](#).
- Right-rear cover. See [Right-rear cover on page 48](#).
- Left cover. See [Left cover on page 50](#).
- Rear-upper cover. See [Rear-upper cover on page 53](#).
- Rear cover. See [Rear cover on page 56](#).
- Secondary transfer assembly. See [Secondary transfer assembly on page 112](#).
- Registration density (RD) sensor assembly. See [Registration density \(RD\) sensor assembly on page 117](#).

 **TIP:** Removing the RD sensor assembly makes it much easier to reinstall the registration assembly.

- Power-supply fan and fan duct. See [Power-supply fan and fan duct on page 121](#).

Remove the registration assembly

 **NOTE:** If a replacement registration assembly is installed, you must use the control-panel menus to reset the registration-roller count.

1. Remove two screws (callout 1).

Figure 1-170 Remove the registration assembly (1 of 8)

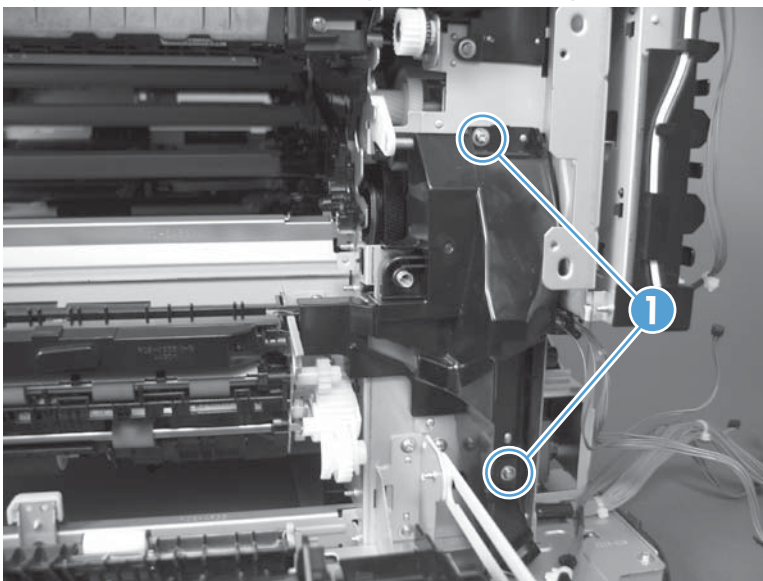

2. Pull down on the cover to release one tab, and then rotate the cover away from the product to remove it.

Figure 1-171 Remove the registration assembly (2 of 8)



3. Release two green latches (callout 2), and then lower the feed guide.

 **Reinstallation tip** Make sure that the feed guide snaps into the closed position when you reinstall the registration assembly.

Figure 1-172 Remove the registration assembly (3 of 8)



4. Remove three screws (callout 3).

Figure 1-173 Remove the registration assembly (4 of 8)

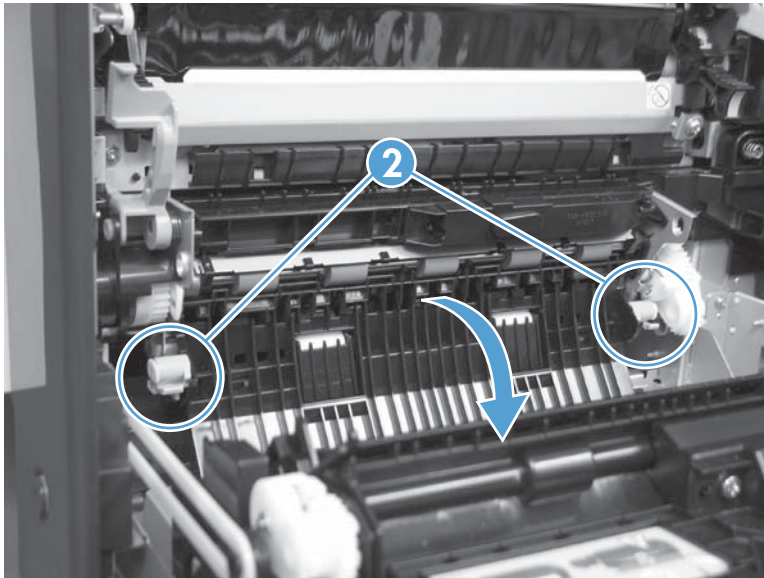
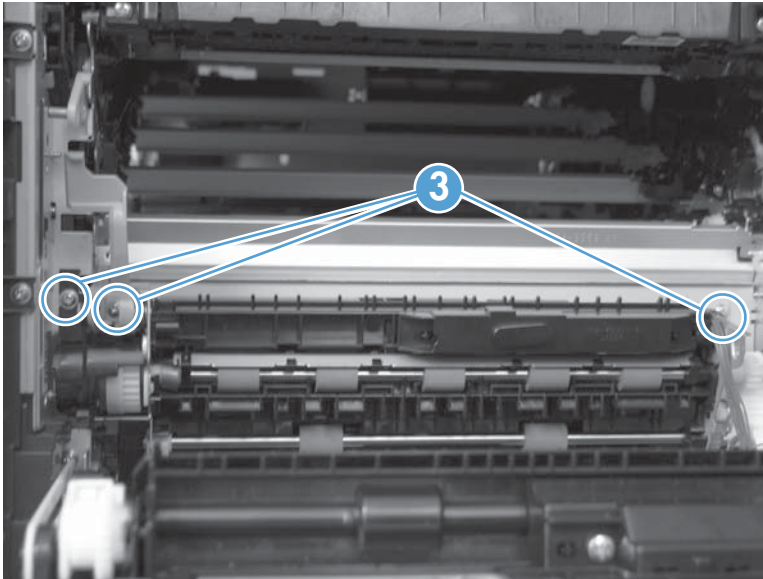

5. Separate the assembly from the product, release one tab (callout 4), and then remove the cover (callout 5).

CAUTION: The assembly is still attached to the product by the wire harnesses.

Figure 1-174 Remove the registration assembly (5 of 8)

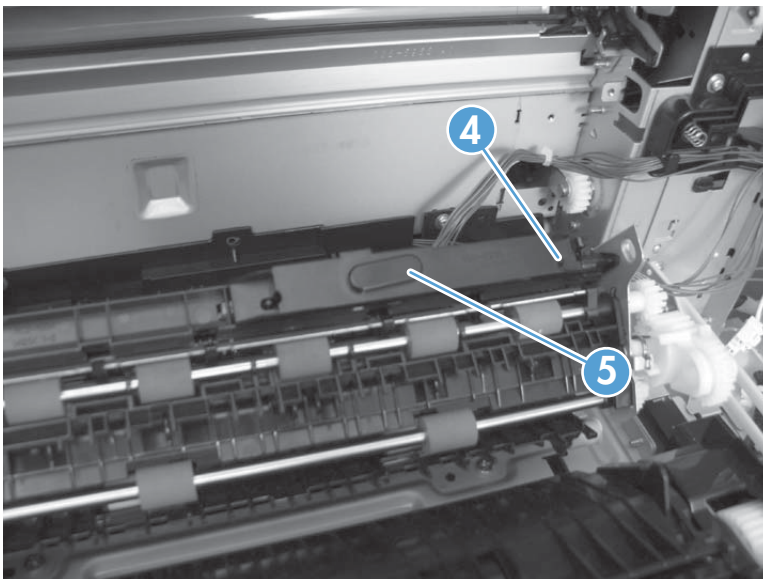

6. Disconnect one connector (callout 6), and then release the wire harness from the retainer.

Figure 1-175 Remove the registration assembly (6 of 8)

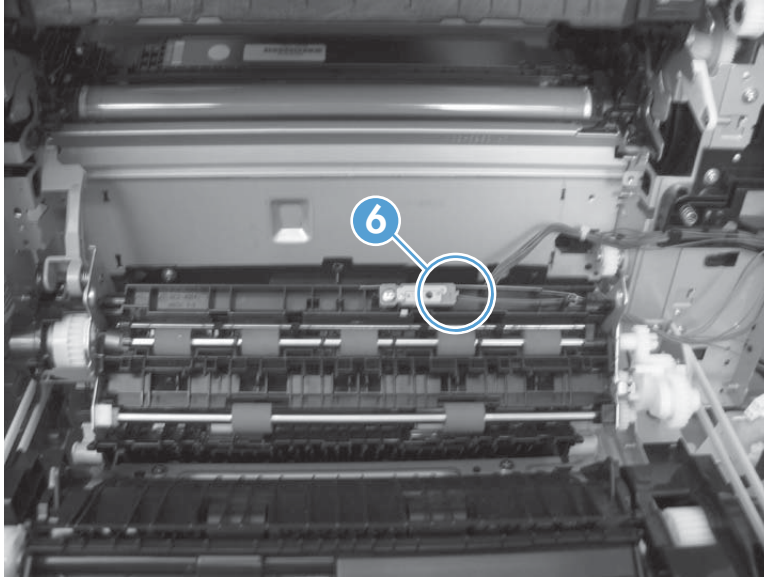

7. Disconnect three connectors (callout 7) on the back side of the assembly, and then release the wires from the retainers.

Figure 1-176 Remove the registration assembly (7 of 8)

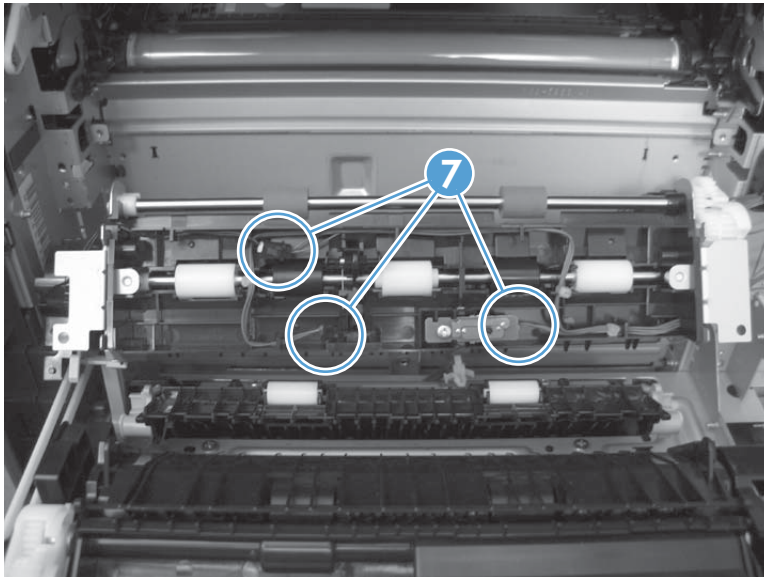

8. Remove the assembly.

 **Reinstallation tip** When you reinstall the registration assembly, make sure that it is correctly positioned in the product. The tabs on the assembly must fit into the slots in the product chassis and the assembly should fit securely up against the product chassis.

Figure 1-177 Remove the registration assembly (8 of 8)



High-voltage power supply lower

Before proceeding, remove the following components:

- Toner-collection unit. See [Toner-collection unit on page 12](#).
- Right-rear cover. See [Right-rear cover on page 48](#).
- Left cover. See [Left cover on page 50](#).
- Rear-upper cover. See [Rear-upper cover on page 53](#).
- Rear cover. See [Rear cover on page 56](#).
- Formatter PCA. See [Formatter PCA on page 83](#).
- Interconnect board (ICB). See [Interconnect board \(ICB\) on page 88](#).
- Low-voltage power supply (LVPS). See [Low-voltage power supply \(LVPS\) on page 94](#).

Remove the high-voltage power supply lower

CAUTION:  ESD-sensitive part.

1. Disconnect two connectors (callout 1), and then remove three screws (callout 2).

Figure 1-178 Remove the high-voltage power supply lower (1 of 4)

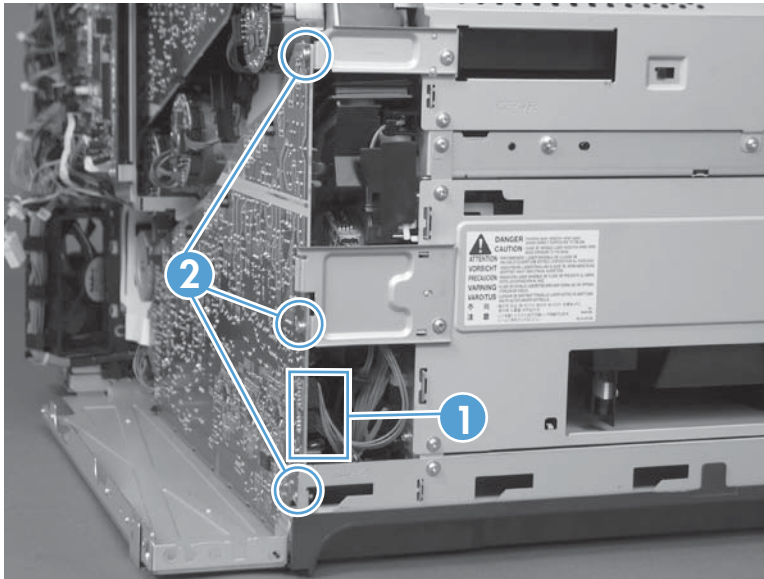

2. Use a small flat blade screwdriver to carefully remove three locking clips (callout 3).

⚠ CAUTION: Do not damage the PCA with the screwdriver.

Figure 1-179 Remove the high-voltage power supply lower (2 of 4)

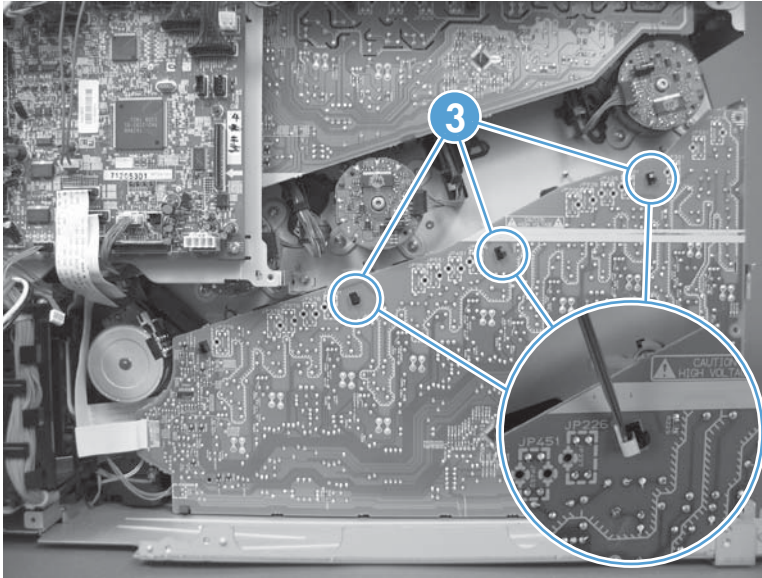

3. Disconnect one connector (callout 4; J114), and then release five clips (callout 5).

📝 NOTE: To locate DC controller connector locations, see [DC controller PCA on page 7](#).

Figure 1-180 Remove the high-voltage power supply lower (3 of 4)

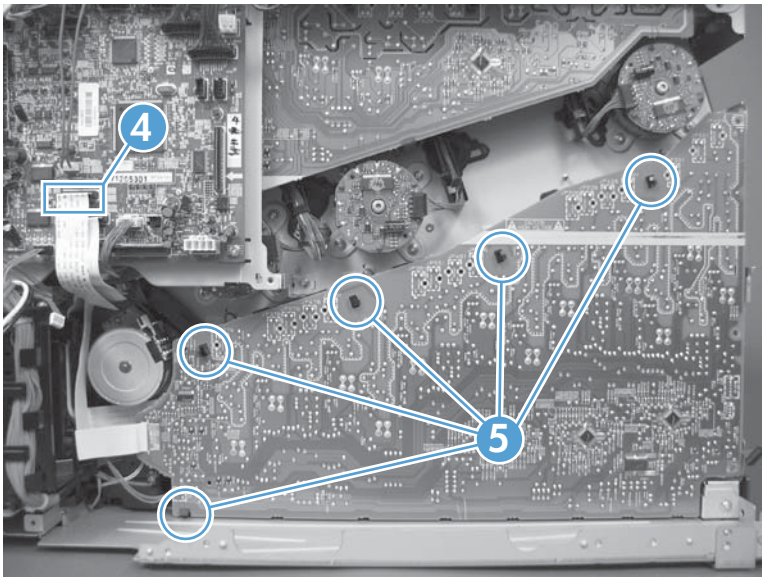

4. Rotate the top of the power supply away from the chassis, and then disconnect one connector (callout 6). Remove the power supply

Figure 1-181 Remove the high-voltage power supply lower (4 of 4)

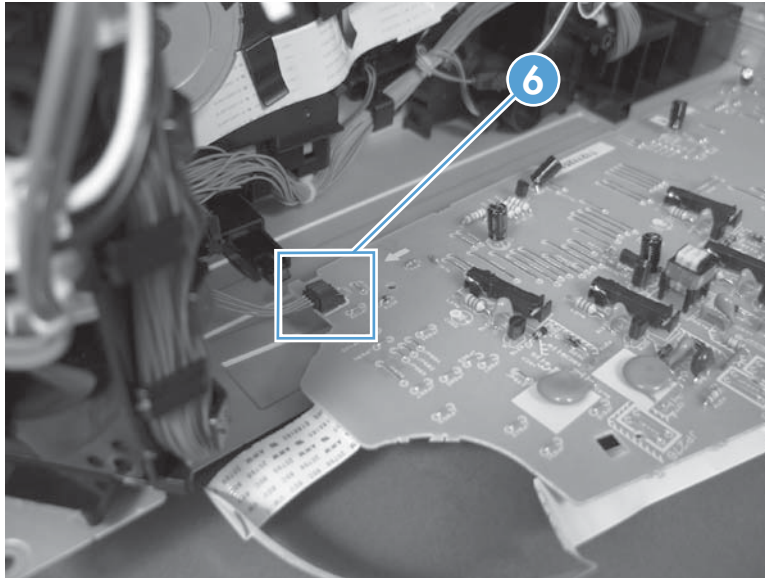

Reinstall the high-voltage power supply lower

When you reinstall the power supply, look through the holes in the PCA and make sure that the high-voltage contact springs are correctly seated against the PCA.

Figure 1-182 Reinstall the high-voltage power supply lower

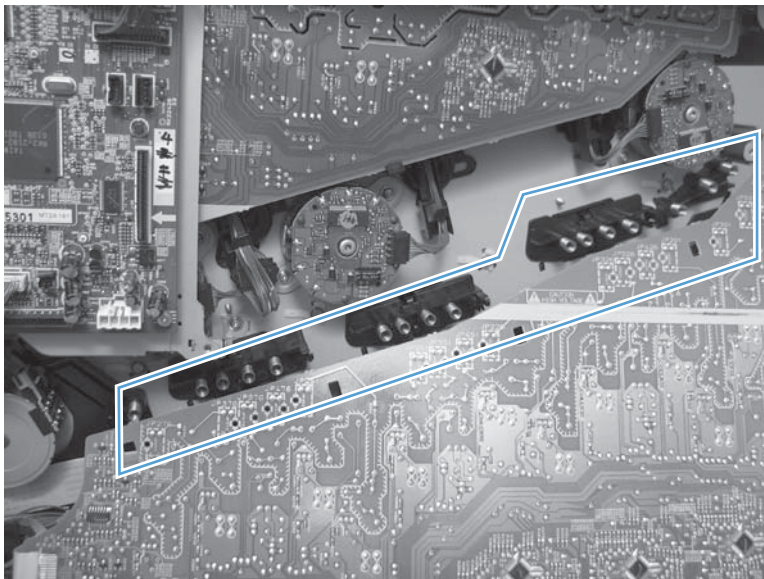

Developing-disengagement motor

Before proceeding, remove the following components:

- Toner-collection unit. See [Toner-collection unit on page 12](#).
- Right-rear cover. See [Right-rear cover on page 48](#).
- Left cover. See [Left cover on page 50](#).
- Rear-upper cover. See [Rear-upper cover on page 53](#).
- Rear cover. See [Rear cover on page 56](#).
- Formatter PCA. See [Formatter PCA on page 83](#).
- Interconnect board (ICB). See [Interconnect board \(ICB\) on page 88](#).
- Low-voltage power supply (LVPS). See [Low-voltage power supply \(LVPS\) on page 94](#).
- High-voltage power supply lower. See [High-voltage power supply lower on page 129](#).

Remove the developing-disengagement motor

1. Remove two screws (callout 1).

Figure 1-183 Remove the developing-disengagement motor (1 of 2)

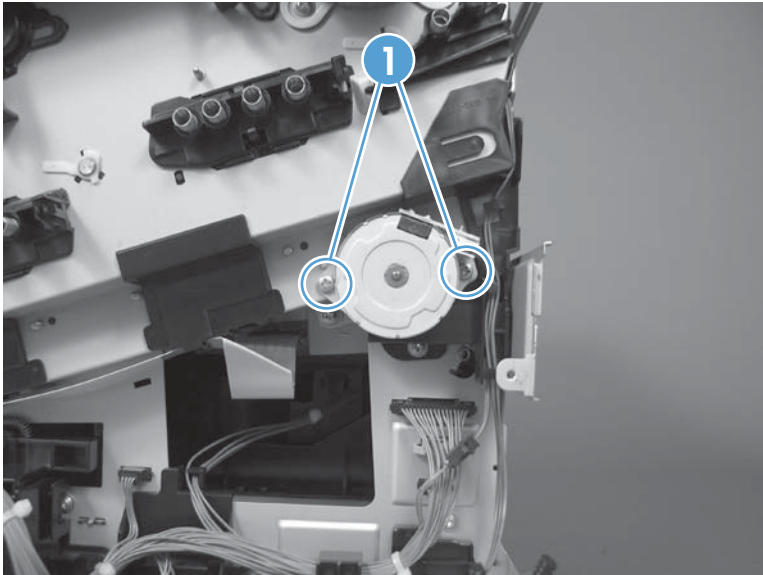

2. Remove the motor.

Figure 1-184 Remove the developing-disengagement motor (2 of 2)

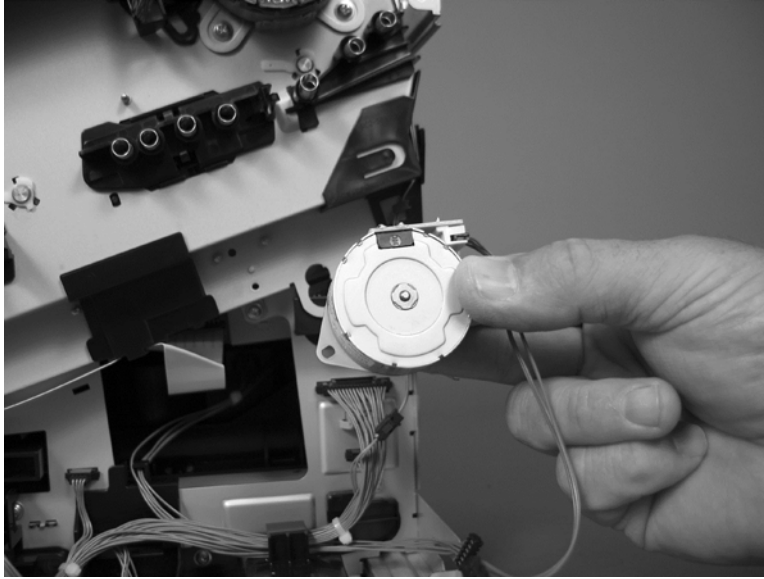

 **Reinstallation tip** Make sure the motor is installed correctly. The PCA on the motor should be on top when the installation is complete.

Pickup motor

Before proceeding, remove the following components:

- Toner-collection unit. See [Toner-collection unit on page 12](#).
- Right-rear cover. See [Right-rear cover on page 48](#).
- Left cover. See [Left cover on page 50](#).
- Rear-upper cover. See [Rear-upper cover on page 53](#).
- Rear cover. See [Rear cover on page 56](#).
- Formatter PCA. See [Formatter PCA on page 83](#).
- Interconnect board (ICB). See [Interconnect board \(ICB\) on page 88](#).
- Low-voltage power supply (LVPS). See [Low-voltage power supply \(LVPS\) on page 94](#).
- High-voltage power supply lower. See [High-voltage power supply lower on page 129](#).

Remove the pickup motor

Disconnect one connector (callout 1), remove two screws (callout 2), and then remove the motor.

Figure 1-185 Remove the pickup motor

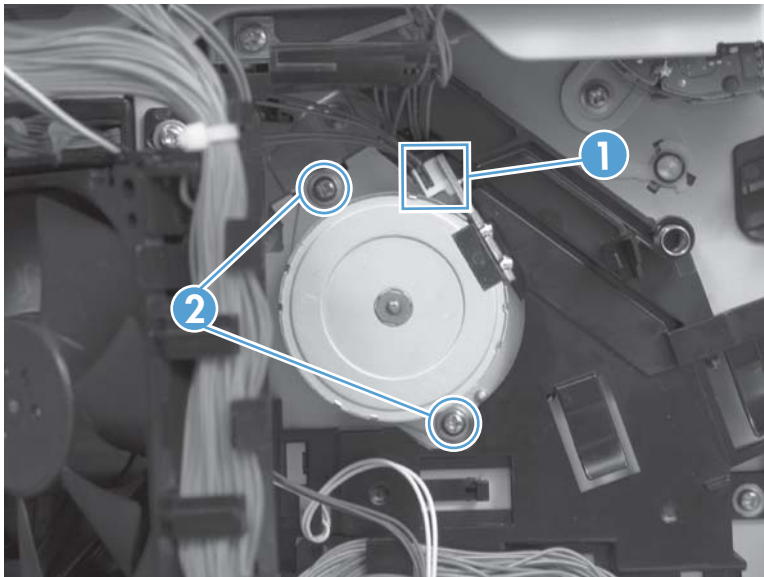

Lifter-drive assembly

Before proceeding, remove the following components:

- Toner-collection unit. See [Toner-collection unit on page 12](#).
- Right-rear cover. See [Right-rear cover on page 48](#).
- Left cover. See [Left cover on page 50](#).
- Rear-upper cover. See [Rear-upper cover on page 53](#).
- Rear cover. See [Rear cover on page 56](#).
- Formatter PCA. See [Formatter PCA on page 83](#).
- Interconnect board (ICB). See [Interconnect board \(ICB\) on page 88](#).
- Low-voltage power supply (LVPS). See [Low-voltage power supply \(LVPS\) on page 94](#).
- High-voltage power supply lower. See [High-voltage power supply lower on page 129](#).

Remove the lifter-drive assembly

1. Disconnect three connectors (callout 1), and then release the wire harness from the retainers.

Figure 1-186 Remove the lifter-drive assembly (1 of 2)

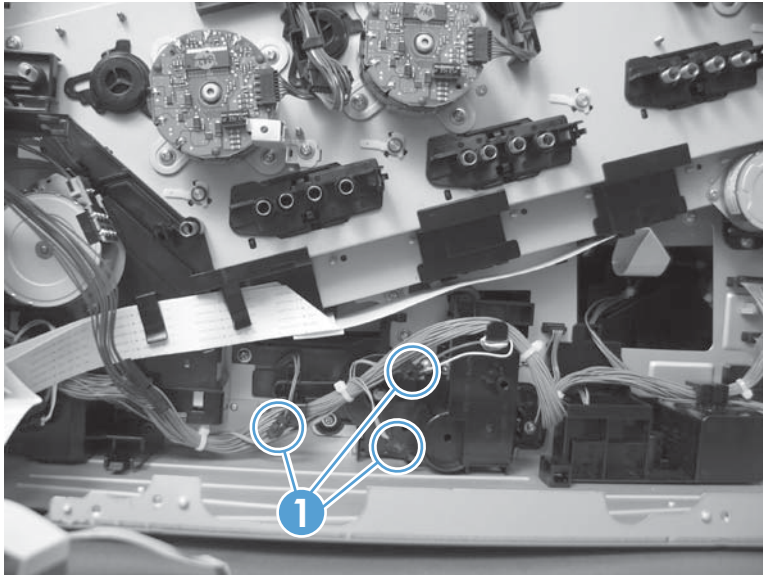

2. Remove five screws (callout 2), and then remove the assembly.

Figure 1-187 Remove the lifter-drive assembly (2 of 2)

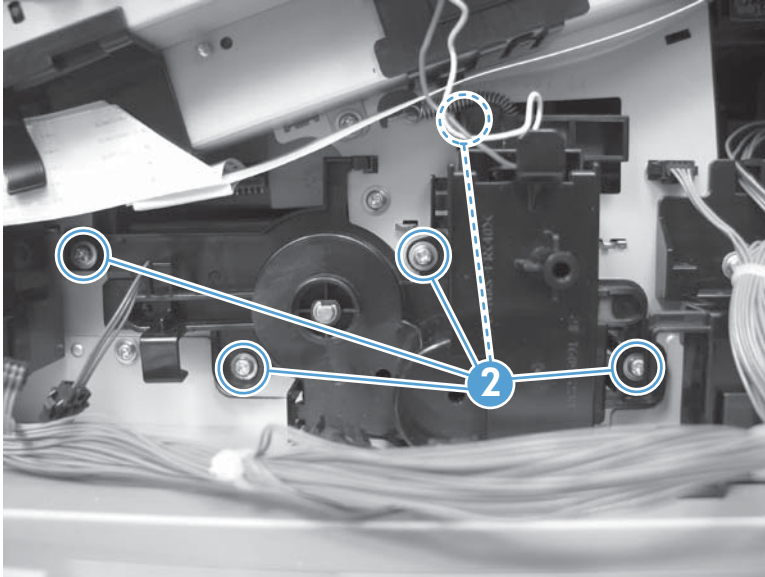

Tray-pickup drive assembly

Before proceeding, remove the following components:

- Toner-collection unit. See [Toner-collection unit on page 12](#).
- Right-rear cover. See [Right-rear cover on page 48](#).
- Left cover. See [Left cover on page 50](#).
- Rear-upper cover. See [Rear-upper cover on page 53](#).
- Rear cover. See [Rear cover on page 56](#).
- Formatter PCA. See [Formatter PCA on page 83](#).
- Interconnect board (ICB). See [Interconnect board \(ICB\) on page 88](#).
- Low-voltage power supply (LVPS). See [Low-voltage power supply \(LVPS\) on page 94](#).
- High-voltage power supply lower. See [High-voltage power supply lower on page 129](#).

Remove the tray-pickup drive assembly

 **NOTE:** To remove the pickup motor only, see [Pickup motor on page 134](#).

1. Remove one screw (callout 1), and then remove the sheet-metal bracket (callout 2).

Figure 1-188 Remove the tray-pickup drive assembly (1 of 10)

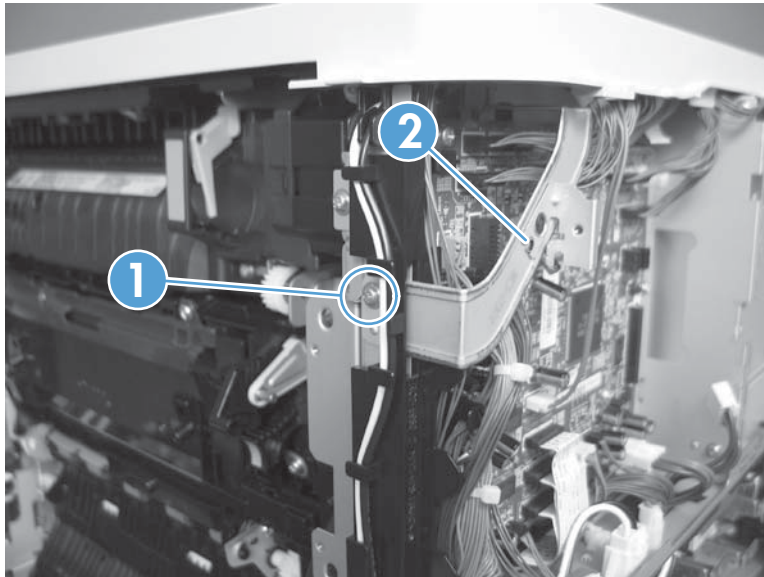

2. Disconnect six connectors (callout 3; J106, J107, J108, J137, J138, J140).

 **NOTE:** To locate DC controller connector locations, see [DC controller PCA on page 7](#).

Figure 1-189 Remove the tray-pickup drive assembly (2 of 10)

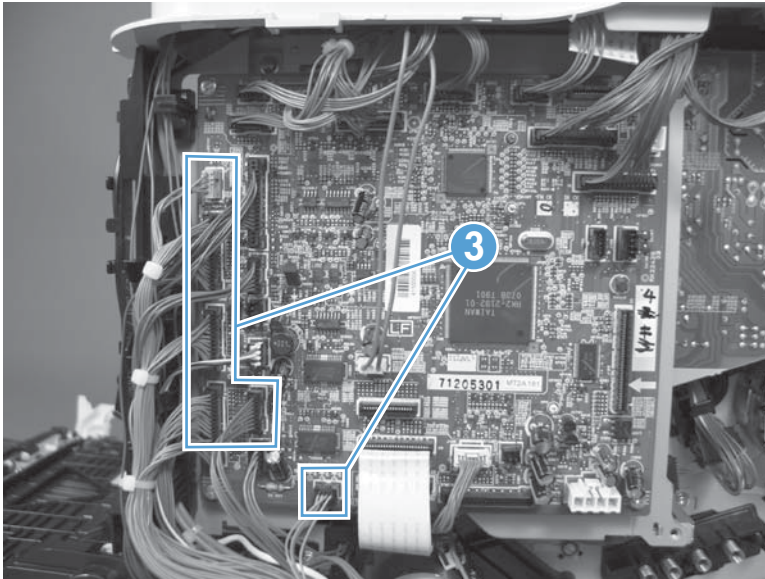

3. Disconnect one connector (callout 4; J119), remove one screw (callout 5), and then release the wire harness from the guides.

 **NOTE:** To locate DC controller connector locations, see [DC controller PCA on page 7](#).

Figure 1-190 Remove the tray-pickup drive assembly (3 of 10)

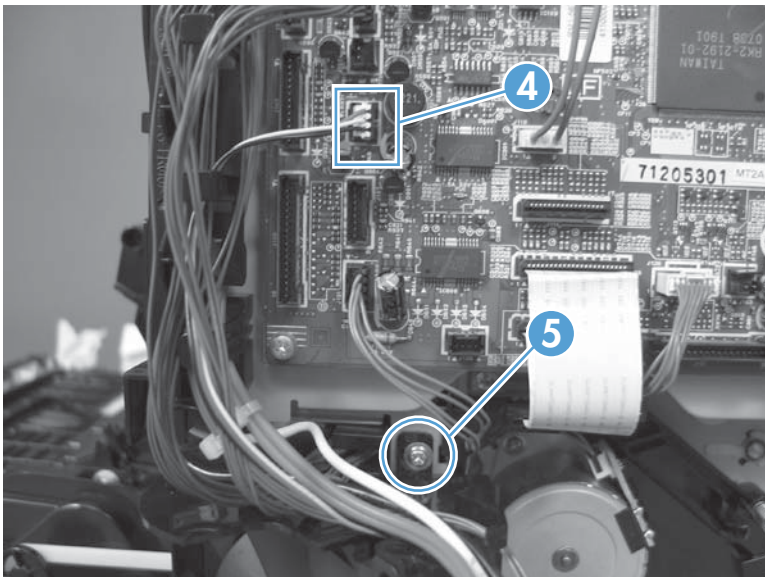

4. Release one tab (callout 6), and then remove the fan and the fan duct (callout 7).

Figure 1-191 Remove the tray-pickup drive assembly (4 of 10)

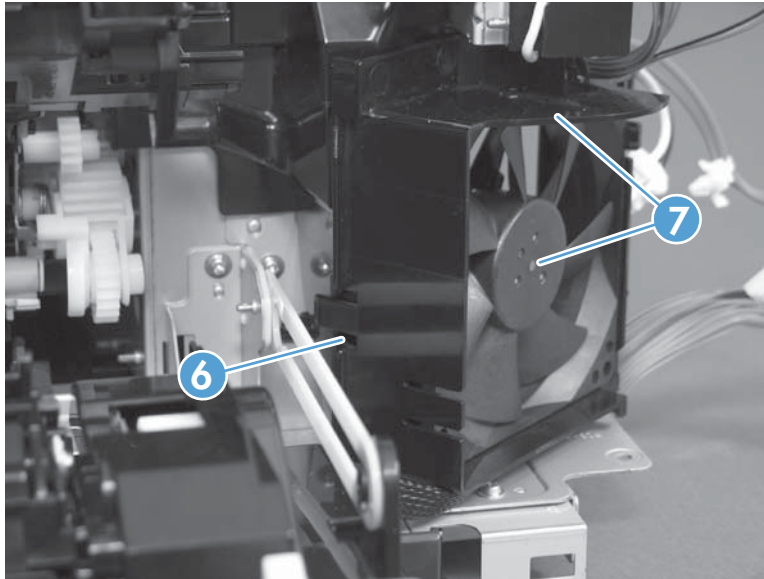

5. Disconnect two FFCs (callout 8; J110, J111 on the DC controller PCA), release the FFCs from the guide (callout 9), and then release the wire harnesses from the guides.

 **NOTE:** To locate DC controller connector locations, see [DC controller PCA on page 7](#).

Figure 1-192 Remove the tray-pickup drive assembly (5 of 10)

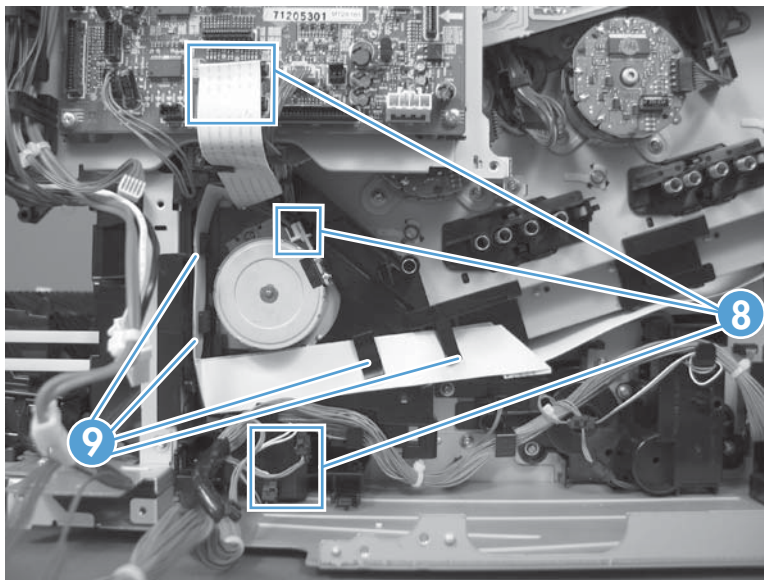

6. Release one tab (callout 10), and then remove the guide.

Figure 1-193 Remove the tray-pickup drive assembly (6 of 10)

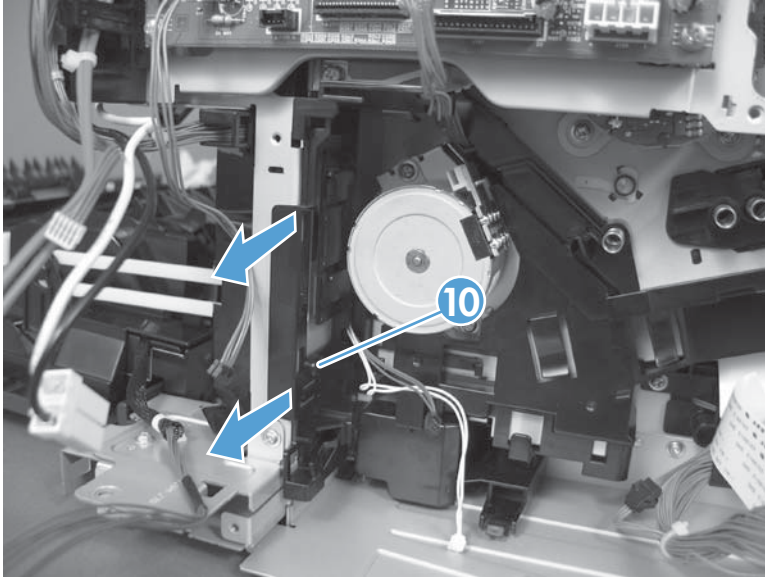

7. Release one tab (callout 11), and then remove the guide.

Figure 1-194 Remove the tray-pickup drive assembly (7 of 10)

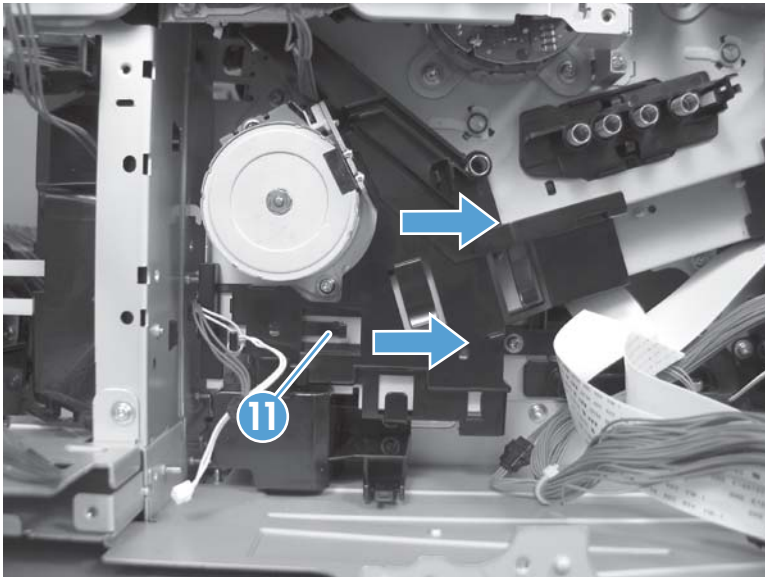

8. Remove two screws (callout 12), and then remove the high-voltage bracket (callout 13).

Figure 1-195 Remove the tray-pickup drive assembly (8 of 10)

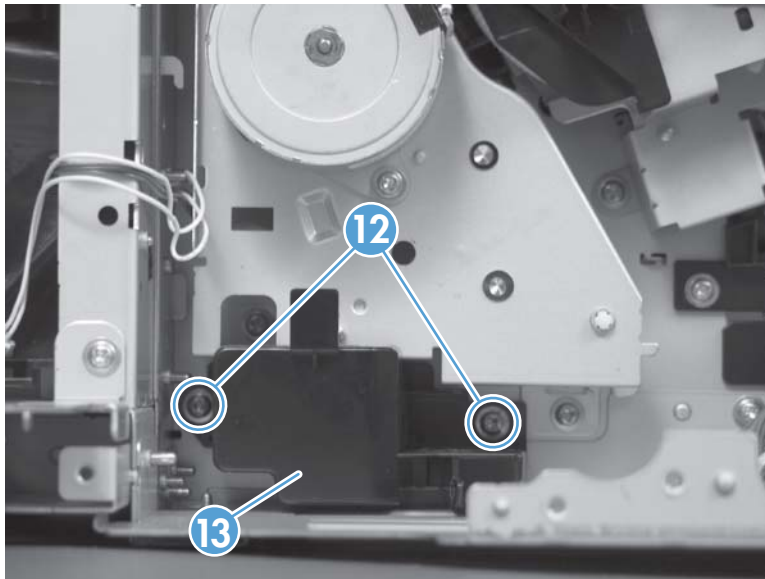

9. Remove three screws (callout 14).

Figure 1-196 Remove the tray-pickup drive assembly (9 of 10)

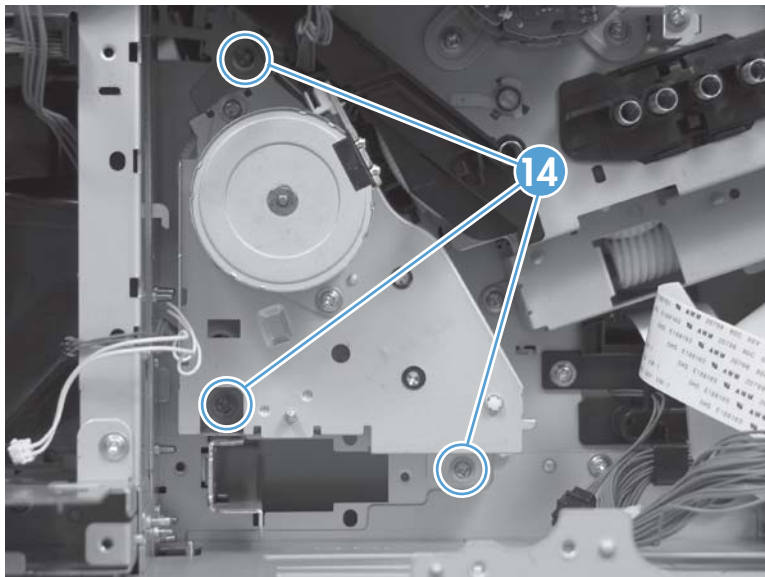

10. Carefully remove the assembly.

⚠ CAUTION: The gears, arm, and spring on the assembly are not captive. Use your finger to secure the arm and spring as you remove the assembly. If the gears, arm, or spring become dislodged, see [Reinstall the tray-pickup drive assembly on page 142](#).

Figure 1-197 Remove the tray-pickup drive assembly (10 of 10)

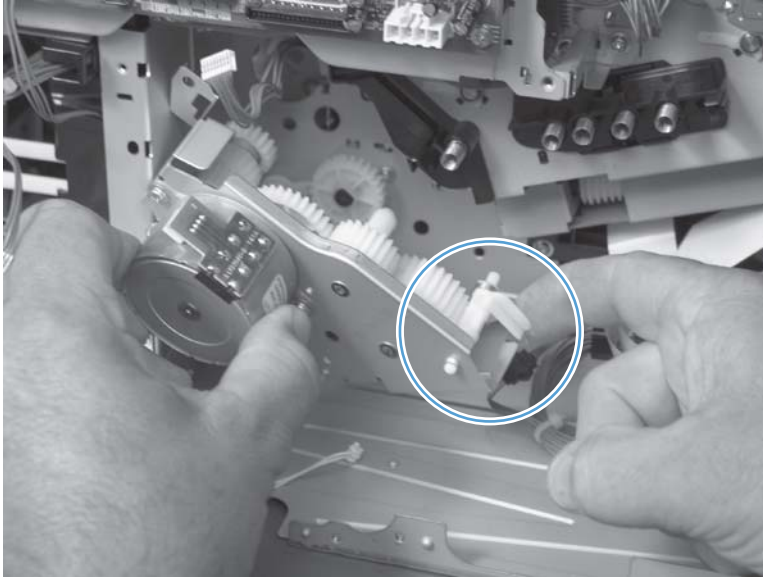

Reinstall the tray-pickup drive assembly

1. Make sure that the spring-loaded gear (callout 1) is correctly installed.

Figure 1-198 Reinstall the tray-pickup drive assembly (1 of 3)

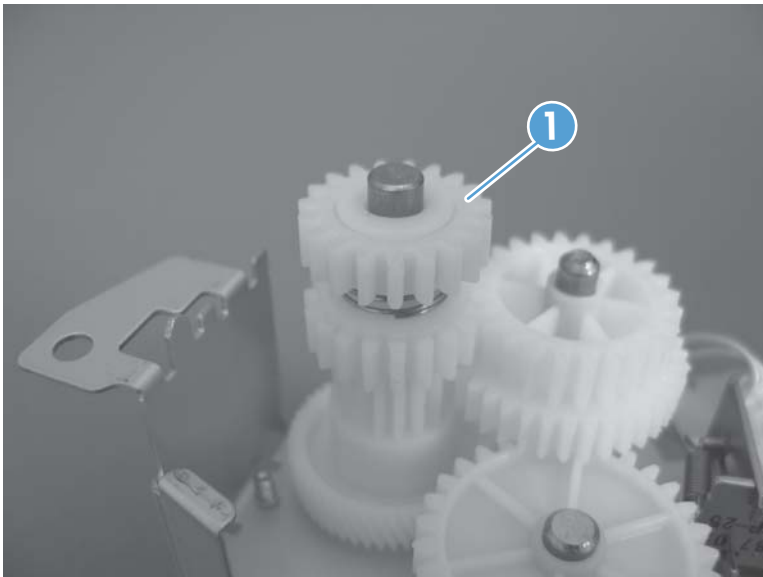

2. Make sure that the spring (callout 2) is correctly installed.

Figure 1-199 Reinstall the tray-pickup drive assembly (2 of 3)

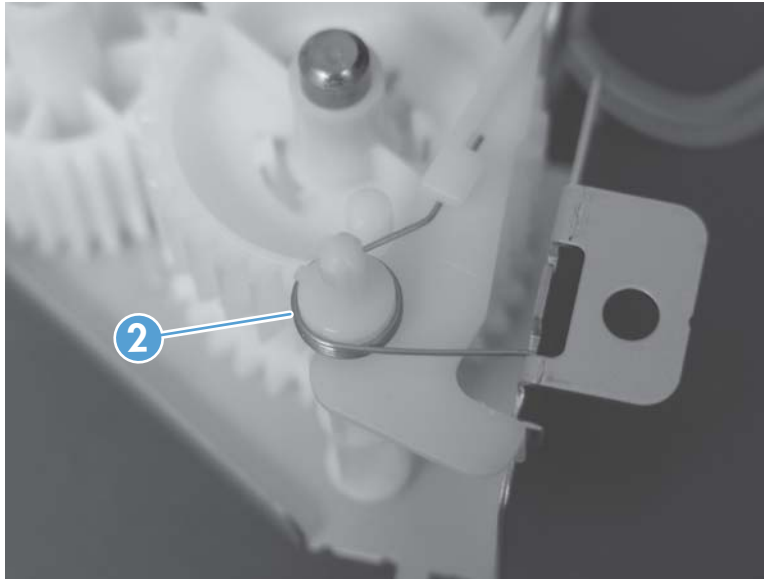

3. Make sure that the gears, arm, and spring are correctly installed.

Figure 1-200 Reinstall the tray-pickup drive assembly (3 of 3)

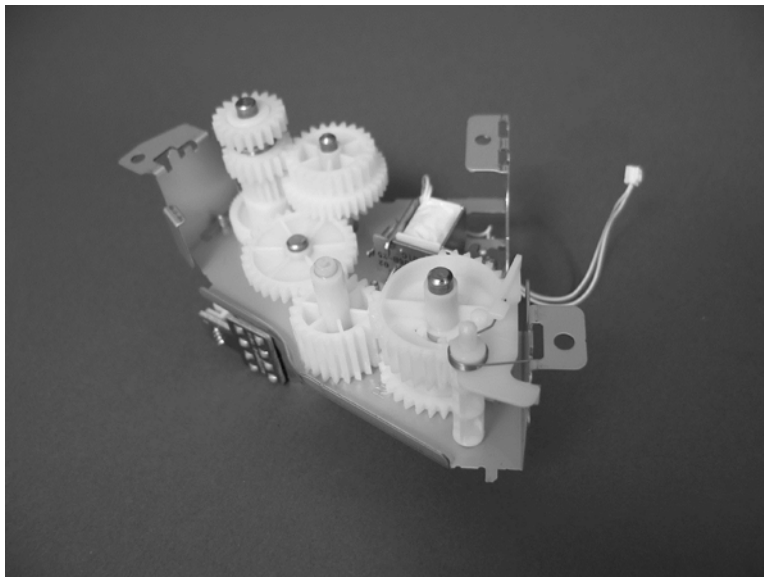

Tray-pickup assembly

Before proceeding, remove the following components:

- Toner-collection unit. See [Toner-collection unit on page 12](#).
- Right-rear cover. See [Right-rear cover on page 48](#).
- Left cover. See [Left cover on page 50](#).
- Rear-upper cover. See [Rear-upper cover on page 53](#).
- Rear cover. See [Rear cover on page 56](#).
- Formatter PCA. See [Formatter PCA on page 83](#).
- Interconnect board (ICB). See [Interconnect board \(ICB\) on page 88](#).
- Low-voltage power supply (LVPS). See [Low-voltage power supply \(LVPS\) on page 94](#).
- Registration density (RD) sensor assembly. See [Registration density \(RD\) sensor assembly on page 117](#).
- High-voltage power supply lower. See [High-voltage power supply lower on page 129](#).
- Tray-pickup drive assembly. See [Tray-pickup drive assembly on page 137](#).

Remove the tray-pickup assembly

1. Release one tab (callout 1), and then remove the gear (callout 2).

Figure 1-201 Remove the tray-pickup assembly (1 of 3)

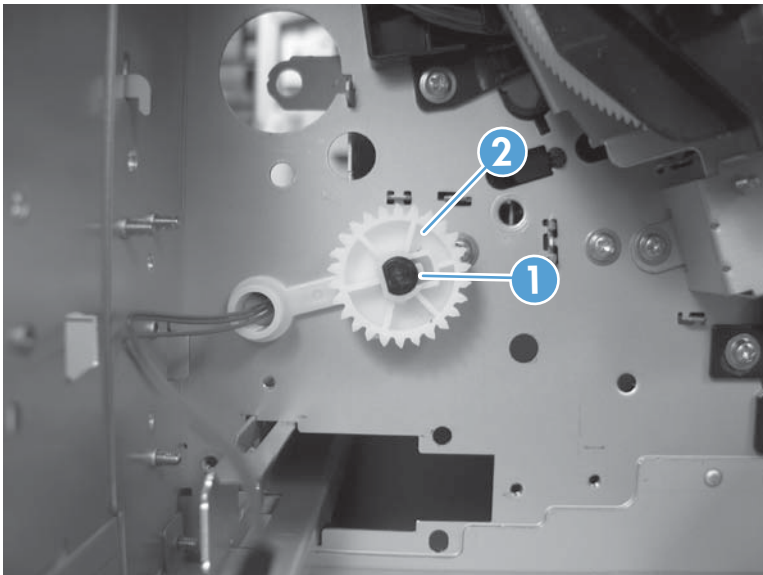

2. Remove two screws (callout 3).

Figure 1-202 Remove the tray-pickup assembly (2 of 3)

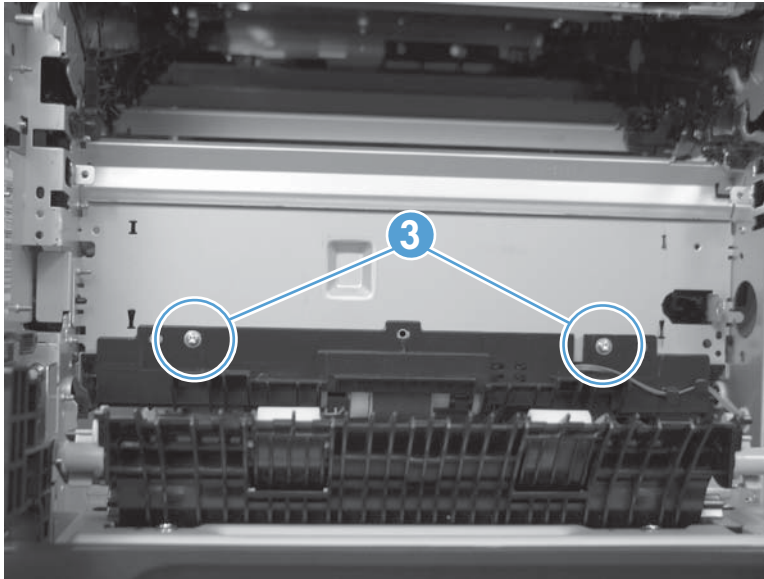

3. Remove the assembly.

Figure 1-203 Remove the tray-pickup assembly (3 of 3)



Laser/scanner assembly (Y/M)

Before proceeding, remove the following components:

- Toner-collection unit. See [Toner-collection unit on page 12](#).
- Right-rear cover. See [Right-rear cover on page 48](#).
- Left cover. See [Left cover on page 50](#).
- Rear-upper cover. See [Rear-upper cover on page 53](#).
- Rear cover. See [Rear cover on page 56](#).
- Formatter PCA. See [Formatter PCA on page 83](#).
- Interconnect board (ICB). See [Interconnect board \(ICB\) on page 88](#).
- Low-voltage power supply (LVPS). See [Low-voltage power supply \(LVPS\) on page 94](#).
- High-voltage power supply lower. See [High-voltage power supply lower on page 129](#).

Remove the laser/scanner assembly (Y/M)

1. Remove five screws (callout 1), and then remove the sheet-metal plate (callout 2).

Figure 1-204 Remove the laser/scanner assembly (Y/M) (1 of 12)

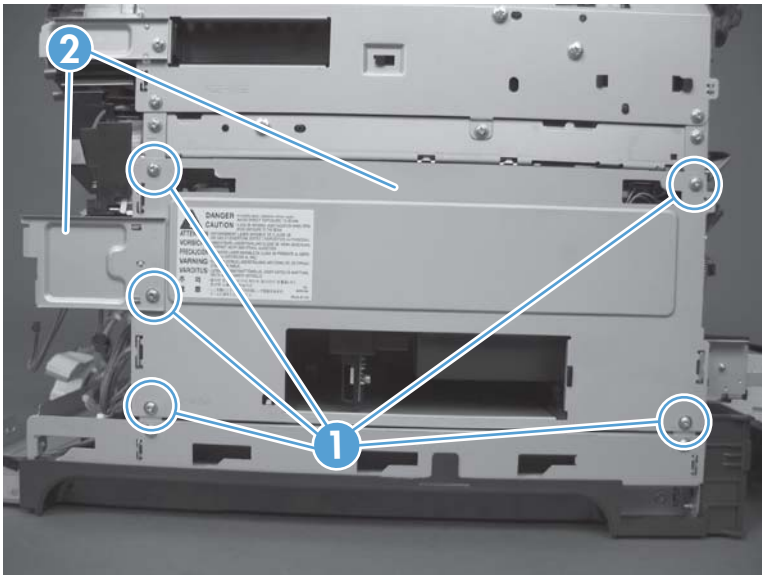

2. Disconnect one in-line connector (callout 3), and then release the wire harnesses from the guide (callout 4).

Figure 1-205 Remove the laser/scanner assembly (Y/M) (2 of 12)

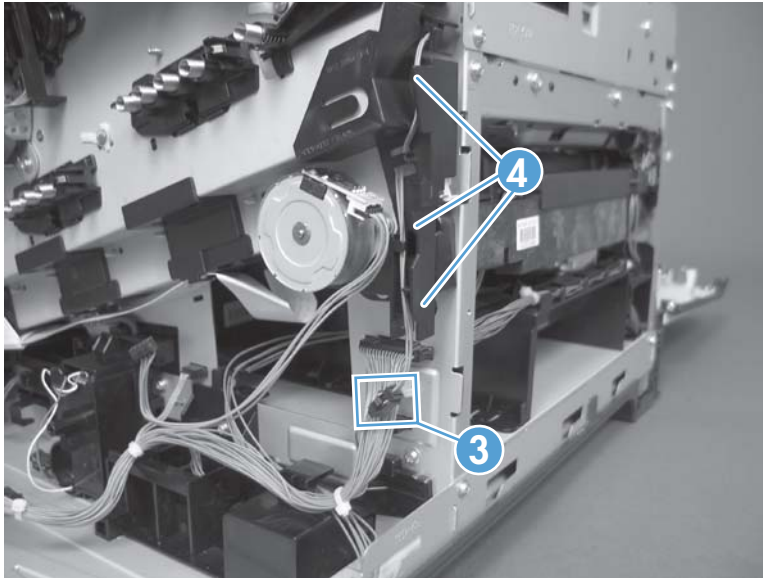

3. Release one tab (callout 5), and then remove the guide (callout 6).

Figure 1-206 Remove the laser/scanner assembly (Y/M) (3 of 12)

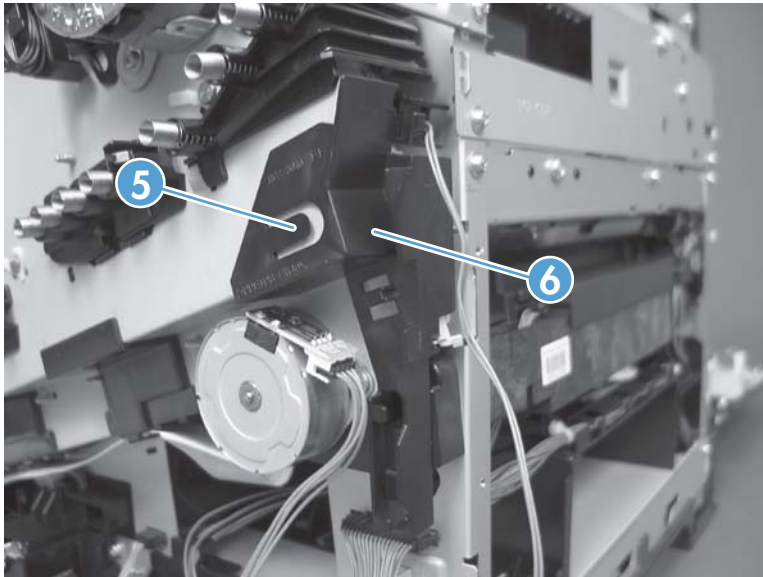

4. Remove one screw (callout 7), and then remove the cover (callout 8).

Figure 1-207 Remove the laser/scanner assembly (Y/M) (4 of 12)

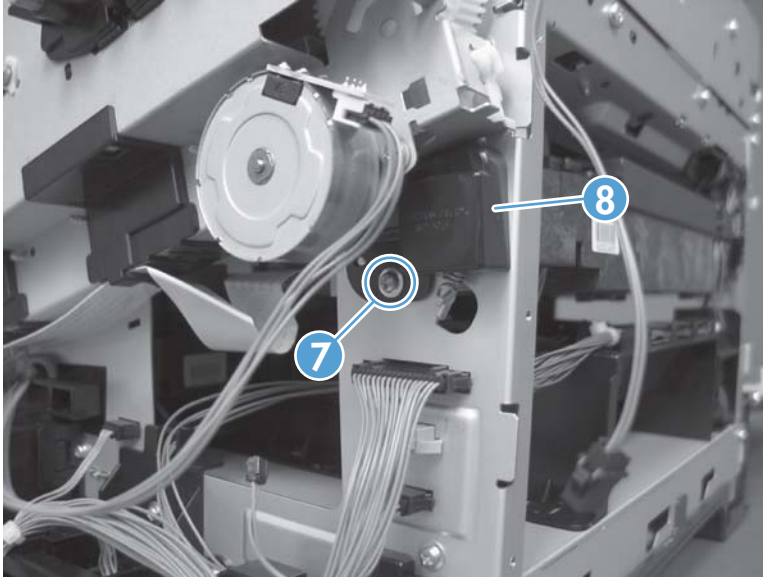

5. Disconnect one FFC (callout 9), and then release one spring (callout 10).

CAUTION: The spring is not captive. Do not lose the spring when it is removed. Use a pair of needle-nose pliers to safely retain the spring when it is removed. Do not use a flat blade screwdriver to remove the spring; the spring could forcibly leave the product and strike you.

Reinstallation tip When you reinstall the spring, make sure that the laser/scanner fits tightly up against the product chassis, and make sure that the FFC is fully seated in the connector. The locator tabs on the front and rear of the scanner must be firmly seated in the slots in the chassis.

Figure 1-208 Remove the laser/scanner assembly (Y/M) (5 of 12)

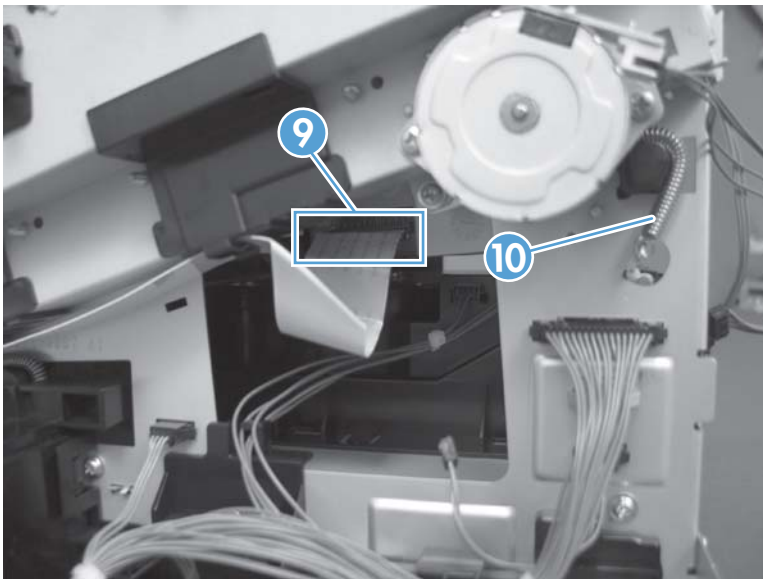

6. Disconnect six connectors (callout 11).

 **NOTE:** Disconnect the larger connector on the right side, from the bottom. Disconnect the two smaller connectors on the right side from the top.

Figure 1-209 Remove the laser/scanner assembly (Y/M) (6 of 12)



7. Release two tabs (callout 12), and then slide the fan assembly toward the power-supply side of the product to release it.

Figure 1-210 Remove the laser/scanner assembly (Y/M) (7 of 12)

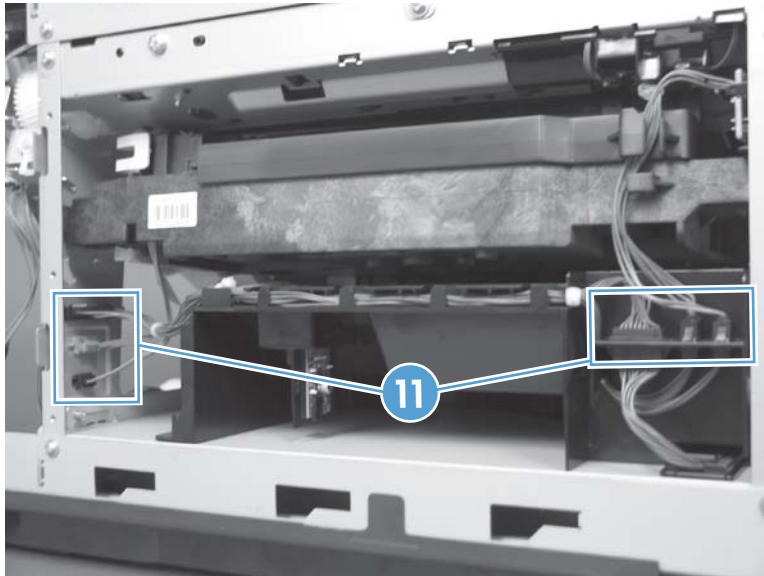
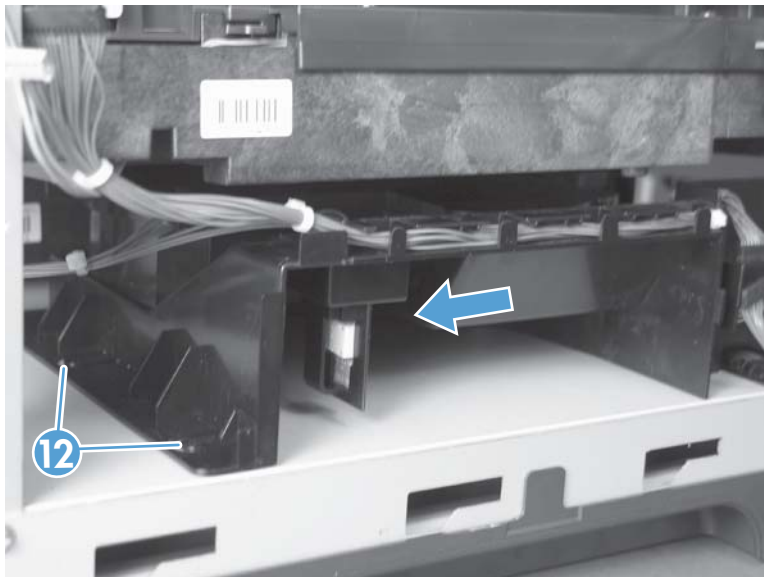

8. Pull the fan assembly slightly out of the product, disconnect two connectors (callout 13), and then remove the assembly.

Figure 1-211 Remove the laser/scanner assembly (Y/M) (8 of 12)

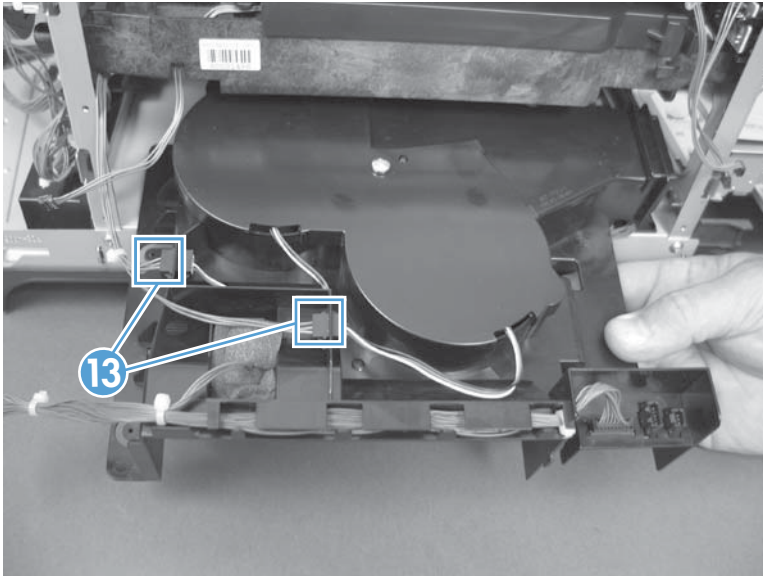

9. Remove one screw (callout 14), and then release one spring (callout 15).

⚠ CAUTION: The spring is not captive. Do not lose the spring when it is removed. Use a pair of needle-nose pliers to safely retain the spring when it is removed. Do not use a flat blade screwdriver to remove the spring; the spring could forcibly leave the product and strike you.

💡 Reinstallation tip When the laser/scanner is properly positioned in the chassis, the plastic parts which protrude at the front and rear of the product will be firmly seated against the locator tabs on the chassis. Verify that the assembly is correctly seated, and then install the spring.

Figure 1-212 Remove the laser/scanner assembly (Y/M) (9 of 12)

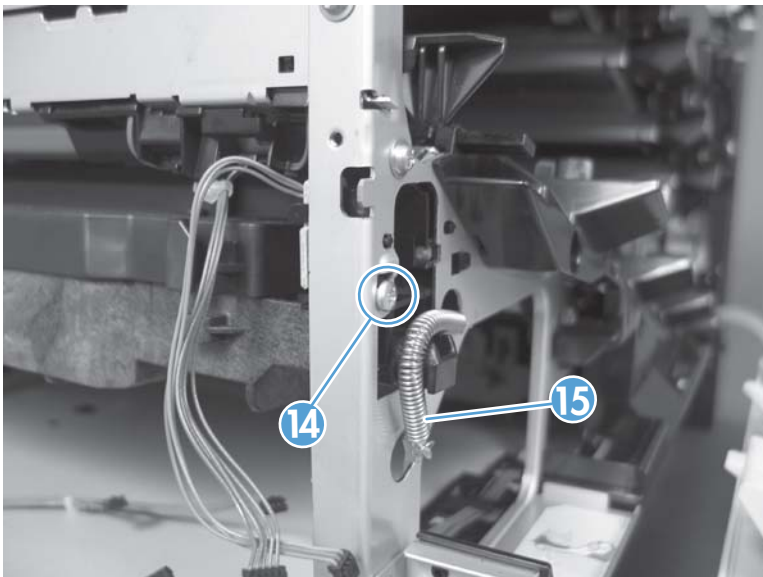

10. Remove the toner collection sensor.

Figure 1-213 Remove the laser/scanner assembly (Y/M) (10 of 12)

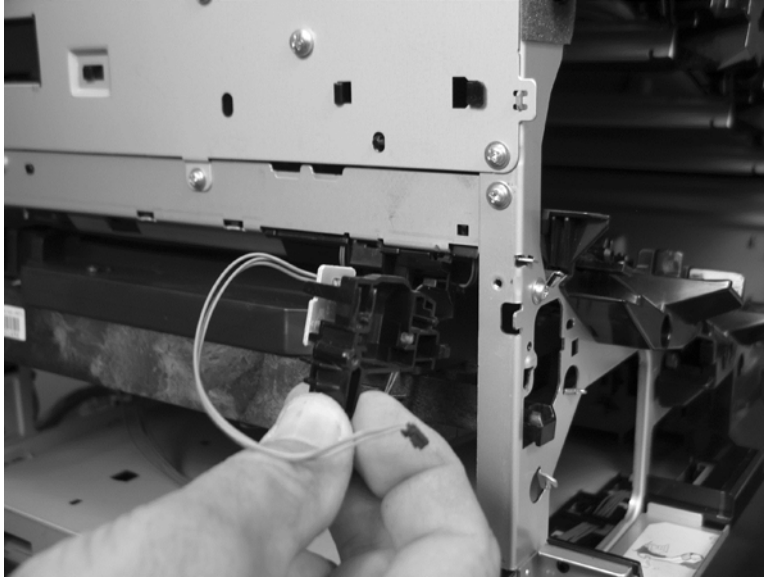

11. Rotate the front of the laser/scanner assembly down (callout 1), and then slide it toward the right (callout 2). Lower the left corner, and then rotate the left corner out of the product (callout 3).

Figure 1-214 Remove the laser/scanner assembly (Y/M) (11 of 12)

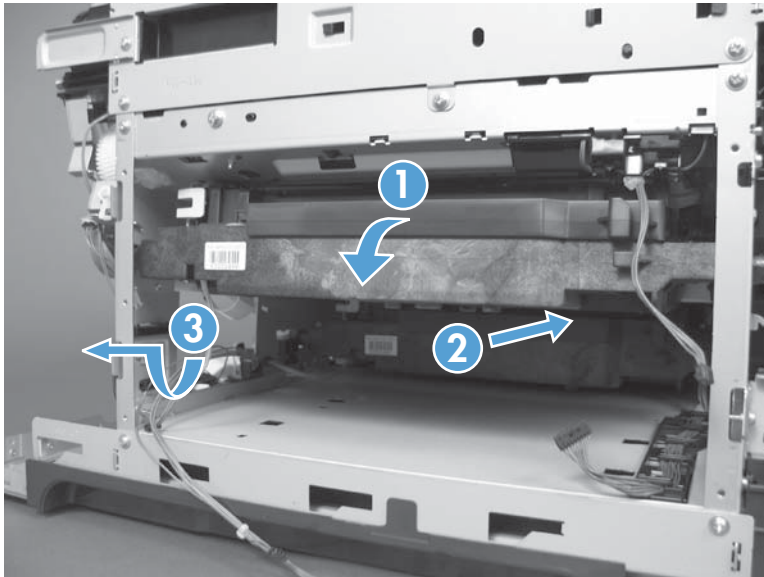

12. Pull the laser/scanner assembly straight out of the product to remove it.

Figure 1-215 Remove the laser/scanner assembly (Y/M) (12 of 12)



Laser/scanner assembly (C/Bk)

Before proceeding, remove the following components:

- Toner-collection unit. See [Toner-collection unit on page 12](#).
- Right-rear cover. See [Right-rear cover on page 48](#).
- Left cover. See [Left cover on page 50](#).
- Rear-upper cover. See [Rear-upper cover on page 53](#).
- Rear cover. See [Rear cover on page 56](#).
- Formatter PCA. See [Formatter PCA on page 83](#).
- Interconnect board (ICB). See [Interconnect board \(ICB\) on page 88](#).
- Low-voltage power supply (LVPS). See [Low-voltage power supply \(LVPS\) on page 94](#).
- High-voltage power supply lower. See [High-voltage power supply lower on page 129](#).
- Lifter drive assembly. See [Lifter-drive assembly on page 135](#).
- Laser/scanner assembly (Y/M). See [Laser/scanner assembly \(Y/M\) on page 146](#).

Remove the laser/scanner assembly (C/Bk)

1. Release one spring (callout 1), and then disconnect one connector (callout 2).

⚠ CAUTION: The spring is not captive. Do not lose the spring when it is removed. Use a pair of needle-nose pliers to safely retain the spring when it is removed. Do not use a flat blade screwdriver to remove the spring; the spring could forcibly leave the product and strike you.

💡 Reinstallation tip When you reinstall the spring, make sure that the laser/scanner fits tightly up against the product chassis, and make sure that the FFC is fully seated in the connector. The locator tabs on the front of the scanner must be firmly seated in the slots in the chassis.

Figure 1-216 Remove the laser/scanner assembly (C/Bk) (1 of 7)

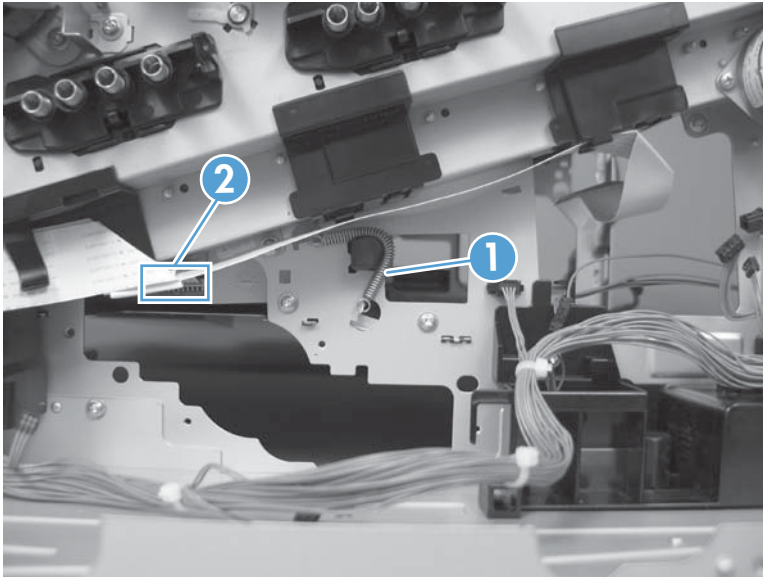

2. Disconnect one connector (callout 3).

Figure 1-217 Remove the laser/scanner assembly (C/Bk) (2 of 7)

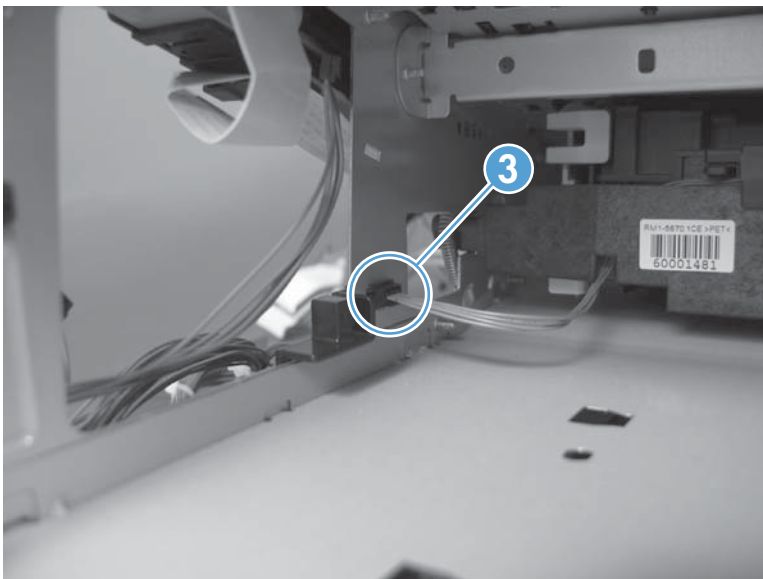

3. Remove two screws (callout 4) located below the front door.

Figure 1-218 Remove the laser/scanner assembly (C/Bk) (3 of 7)

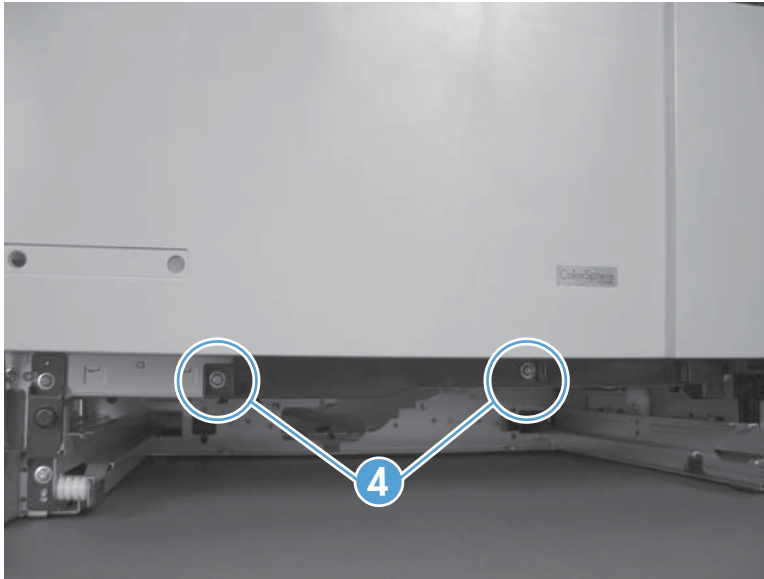

4. Open the front door, and then remove one screw (callout 5) and the cover (callout 6).

Figure 1-219 Remove the laser/scanner assembly (C/Bk) (4 of 7)

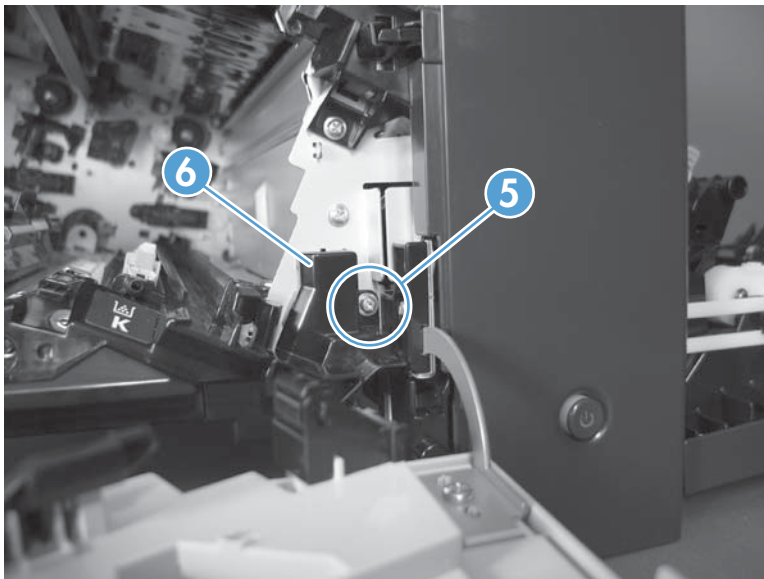

5. Remove two screws (callout 7). Use your finger to release the locking tab (callout 8), and then remove the cover.

CAUTION: Be careful. The PGC actuators are easily dislodged when the cover is removed. See [Figure 1-223 Reinstall the PGC actuators \(1 of 5\) on page 158](#). To reinstall the actuators, see [Reinstall the protective glass cleaner \(PGC\) actuators on page 158](#).

Figure 1-220 Remove the laser/scanner assembly (C/Bk) (5 of 7)

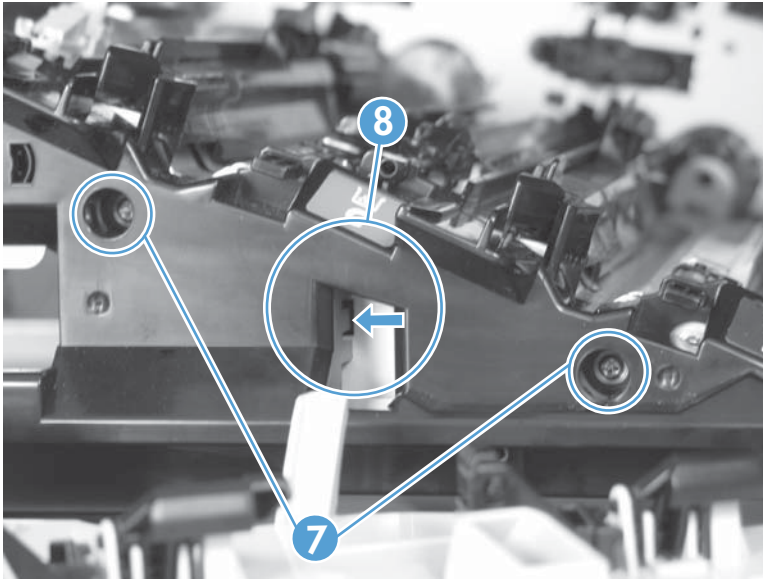

6. Release one spring (callout 9).

⚠ CAUTION: The spring is not captive. Do not lose the spring when it is removed. Use a pair of needle-nose pliers to safely retain the spring when it is removed. Do not use a flat blade screwdriver to remove the spring; the spring could forcibly leave the product and strike you.

💡 Reinstallation tip When you reinstall the spring, make sure that the laser/scanner fits tightly up against the product chassis.

Figure 1-221 Remove the laser/scanner assembly (C/Bk) (6 of 7)

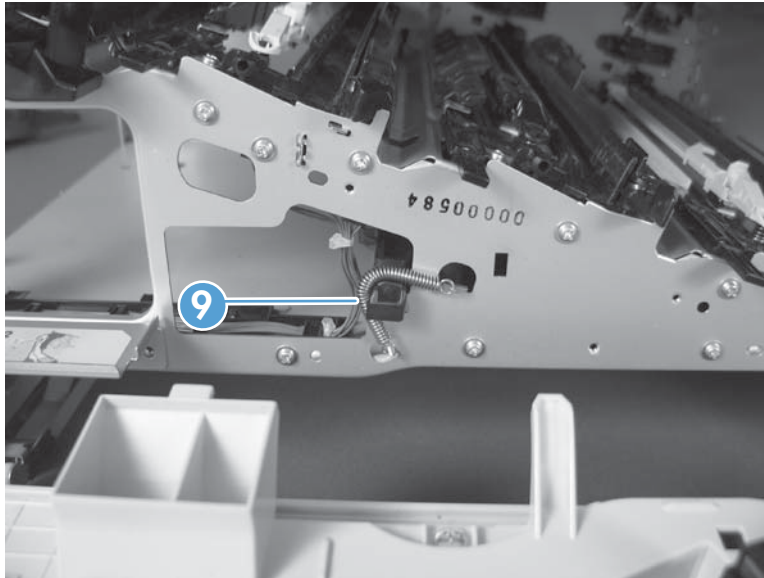

7. Rotate the corner of the assembly away from the product until you can see the PCA, and then remove the assembly from the product.

 **Reinstallation tip** When the laser/scanner is properly positioned in the chassis, the plastic parts which protrude at the front and rear of the product will be firmly seated against the locator tabs on the chassis. Verify that the assembly is correctly seated, and then install the spring.

Figure 1-222 Remove the laser/scanner assembly (C/Bk) (7 of 7)



Reinstall the protective glass cleaner (PGC) actuators

1. The following figure shows a dislodged PGC actuator.

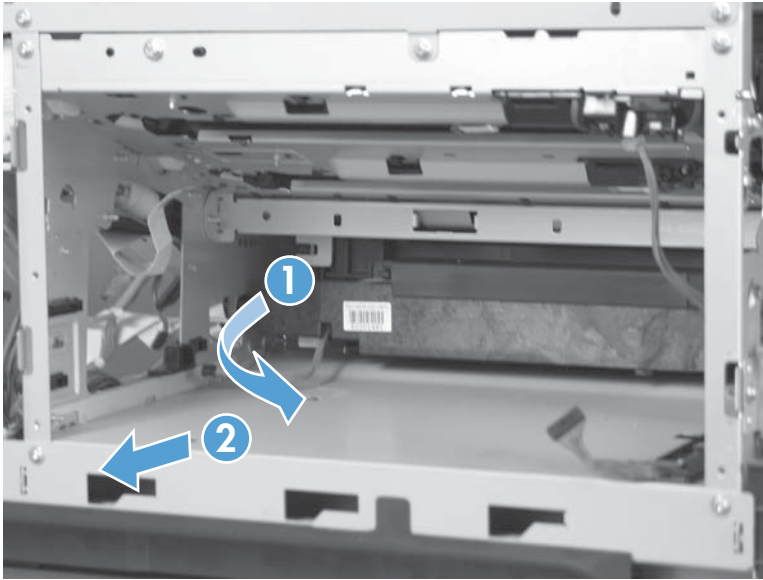
 **TIP:** If the actuator and spring are only slightly dislodged, you might be able to easily push them back into place.

Figure 1-223 Reinstall the PGC actuators (1 of 5)



2. Remove the actuator and spring from the product. Install the spring on the actuator.

Figure 1-224 Reinstall the PGC actuators (2 of 5)

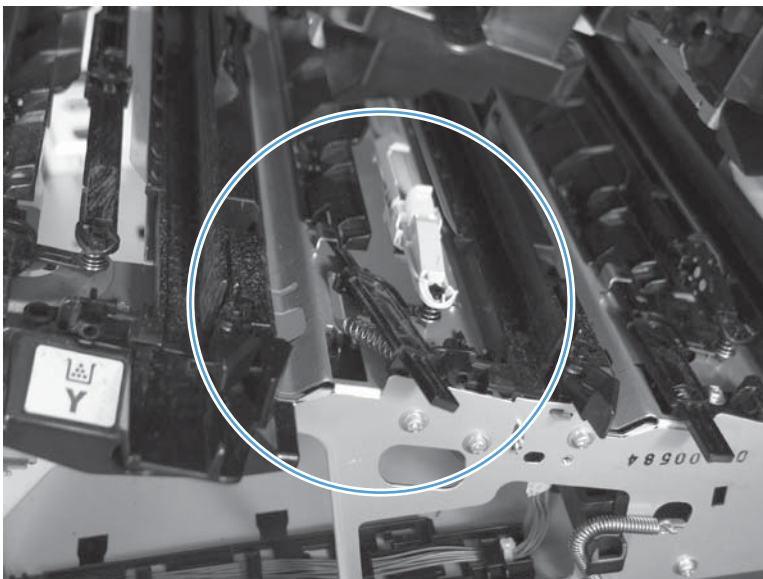

3. Before proceeding, take note of the following:
 - **Callout 1:** The pin on the actuator will be installed into the slot in the chassis.
 - **Callout 2:** The pin on the pivot arm will be installed into the slot on the actuator.
 - **Callout 3:** The end of the spring will be installed onto the tab on the chassis.

Figure 1-225 Reinstall the PGC actuators (3 of 5)

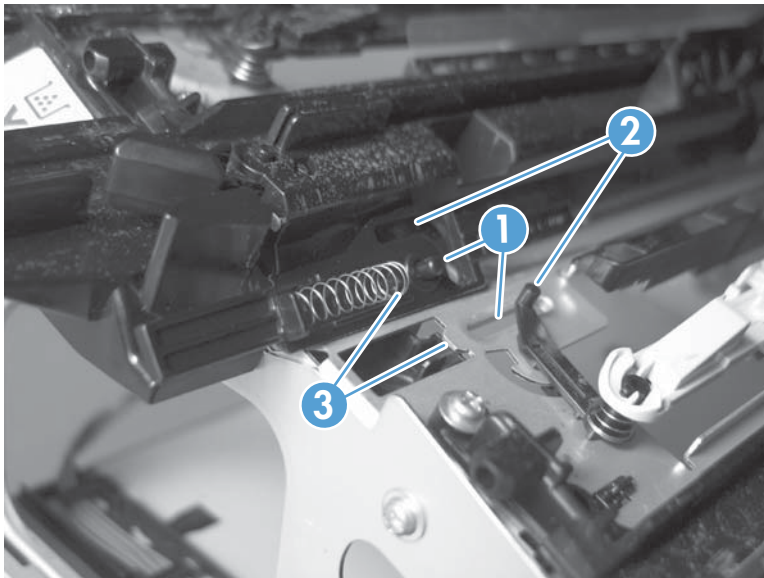

4. Place the end of the actuator into the PGC rod, and then use a small flat blade screw driver to fasten the end of the spring on the tab on the chassis.

Figure 1-226 Reinstall the PGC actuators (4 of 5)

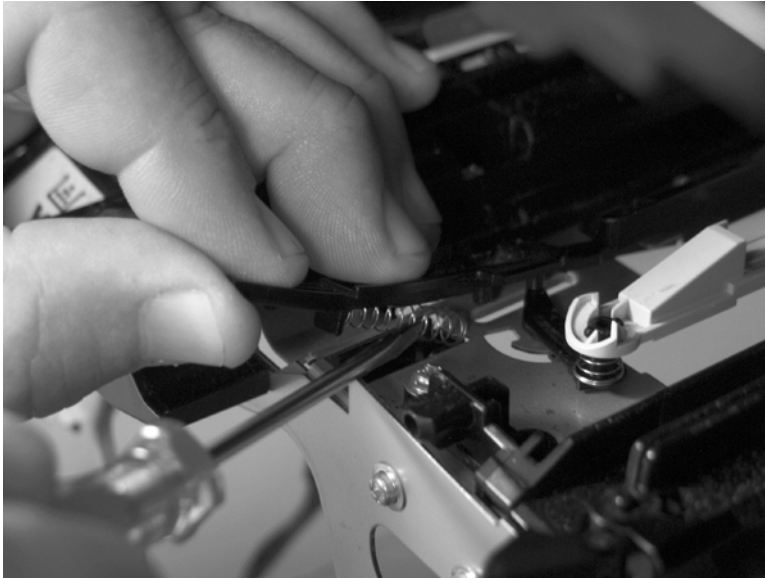

5. Push down on the actuator to seat it into place. Verify that the actuator is correctly installed. The PGC actuator should freely move when you push in on the actuator.

Figure 1-227 Reinstall the PGC actuators (5 of 5)

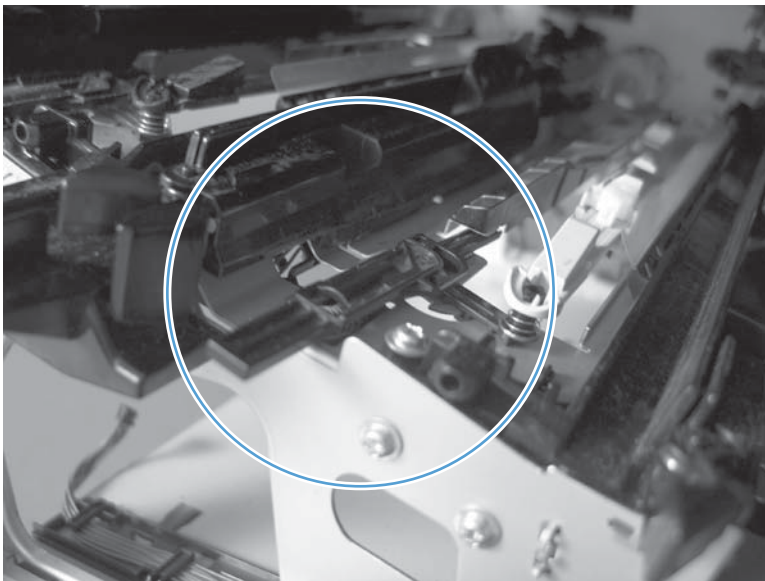

High-voltage power supply upper

Before proceeding, remove the following components:

- Toner-collection unit. See [Toner-collection unit on page 12](#).
- Right-rear cover. See [Right-rear cover on page 48](#).
- Left cover. See [Left cover on page 50](#).
- Rear-upper cover. See [Rear-upper cover on page 53](#).
- Rear cover. See [Rear cover on page 56](#).
- Formatter PCA. See [Formatter PCA on page 83](#).
- Interconnect board (ICB). See [Interconnect board \(ICB\) on page 88](#).
- DC controller. See [DC controller PCA and tray on page 91](#).
- Low-voltage power supply (LVPS). See [Low-voltage power supply \(LVPS\) on page 94](#).

Remove the high-voltage power supply upper

CAUTION:  ESD-sensitive part.

1. Remove one screw (callout 1).

Figure 1-228 Remove the high-voltage power supply upper (1 of 5)

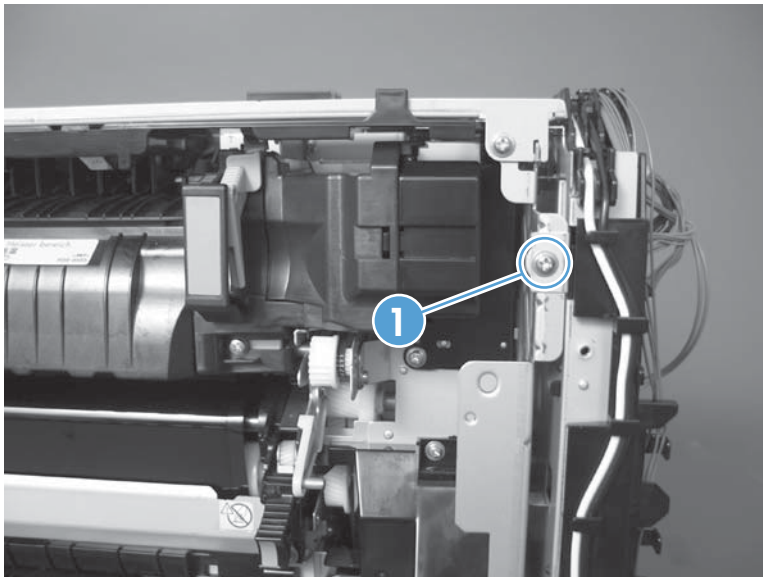

2. Remove four screws (callout 2), and then rotate the sheet-metal plate away from the power supply.

 **NOTE:** You do not need to completely remove the sheet-metal plate to access the power supply.

Figure 1-229 Remove the high-voltage power supply upper (2 of 5)



3. Disconnect two connectors (J201, J202; callout 3) from the back side of the power supply.

 **NOTE:** For clarity, the figure in this step shows the ADF and scanner removed. Carefully reach under these components to access the two connectors.

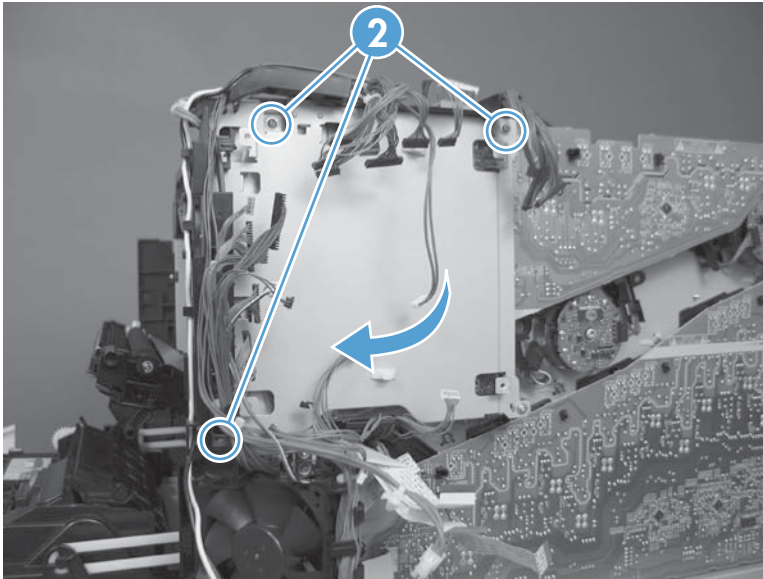
Figure 1-230 Remove the high-voltage power supply upper (3 of 5)



4. Remove three screws (callout 4).

Figure 1-231 Remove the high-voltage power supply upper (4 of 5)

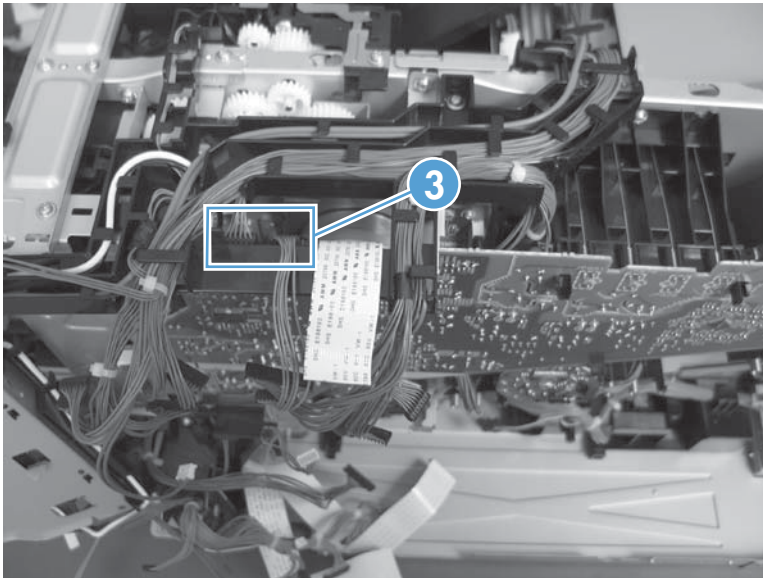
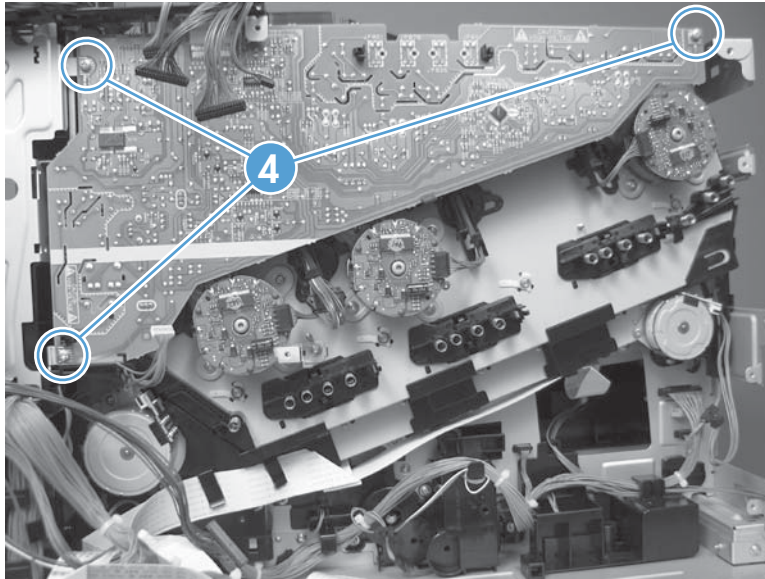

5. Release four tabs (callout 5), and then remove the power supply.

Figure 1-232 Remove the high-voltage power supply upper (5 of 5)

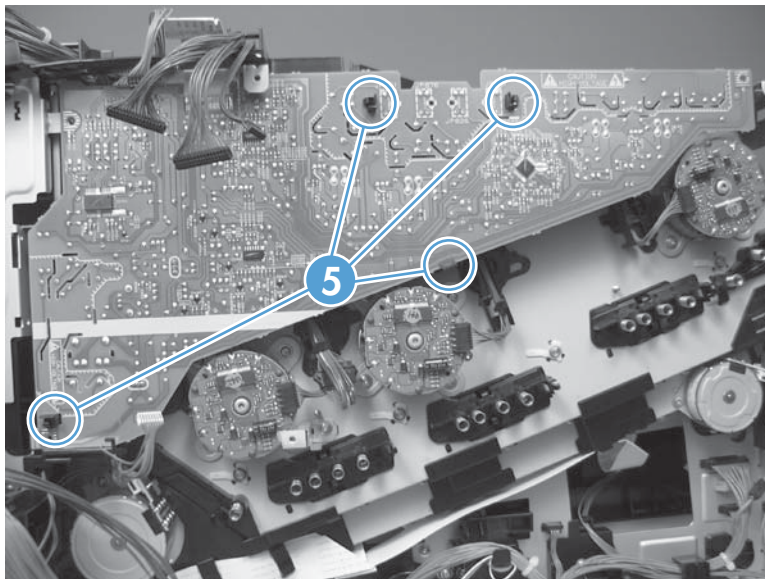

Reinstall the high-voltage power supply upper

When you reinstall the power supply, look through the holes in the PCA and make sure that the high-voltage contact springs are correctly seated against the PCA.

 **NOTE:** One wire harness (callout 1) is disconnected at both ends. Do not lose the wire harness.

Position the FFC (callout 2) *over* the cable guide when you reinstall the power supply.

Figure 1-233 Reinstall the high-voltage power supply upper

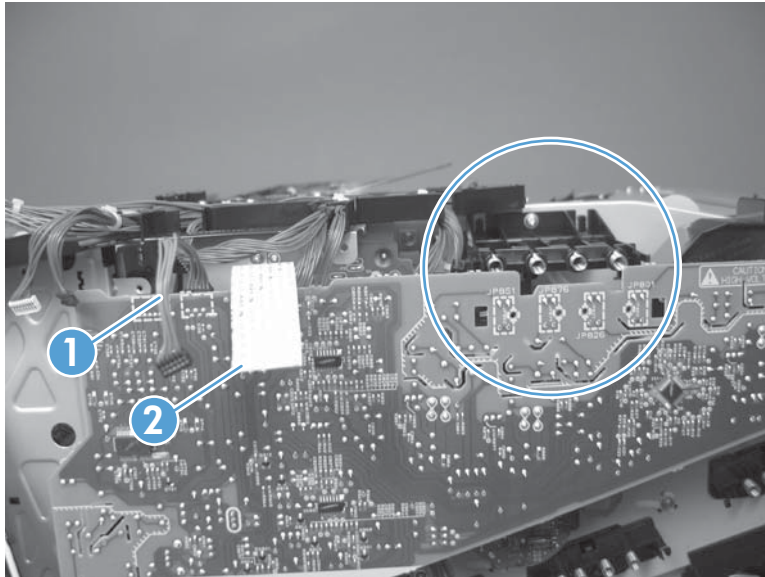

Drum motor 1

Before proceeding, remove the following components:

- Toner-collection unit. See [Toner-collection unit on page 12](#).
- Right-rear cover. See [Right-rear cover on page 48](#).
- Left cover. See [Left cover on page 50](#).
- Rear-upper cover. See [Rear-upper cover on page 53](#).
- Rear cover. See [Rear cover on page 56](#).
- Interconnect board (ICB). See [Interconnect board \(ICB\) on page 88](#).
- DC controller. See [DC controller PCA and tray on page 91](#).
- Low-voltage power supply (LVPS). See [Low-voltage power supply \(LVPS\) on page 94](#).
- High-voltage power supply upper. See [High-voltage power supply upper on page 161](#).

Remove the drum motor 1

- ▲ Disconnect one connector (callout 1), remove four screws (callout 2), and then remove the motor.

Figure 1-234 Remove the drum motor 1

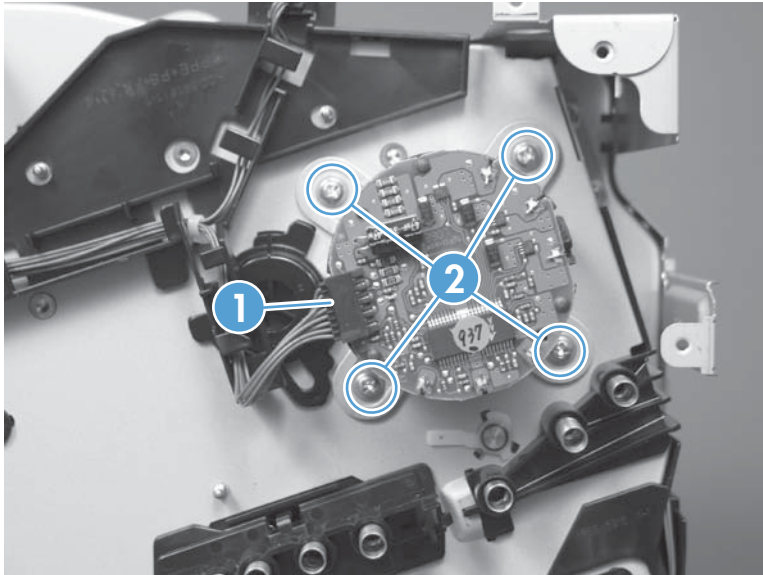

Drum motor 2 or drum motor 3

Before proceeding, remove the following components:

- Toner-collection unit. See [Toner-collection unit on page 12](#).
- Right-rear cover. See [Right-rear cover on page 48](#).
- Left cover. See [Left cover on page 50](#).
- Rear-upper cover. See [Rear-upper cover on page 53](#).
- Rear cover. See [Rear cover on page 56](#).
- Interconnect board (ICB). See [Interconnect board \(ICB\) on page 88](#).
- DC controller. See [DC controller PCA and tray on page 91](#).
- Low-voltage power supply (LVPS). See [Low-voltage power supply \(LVPS\) on page 94](#).
- High-voltage power supply upper. See [High-voltage power supply upper on page 161](#).

Remove the drum motor 2 or drum motor 3

▲ Do one of the following:

- Remove drum motor 2: Disconnect one connector (callout 1), remove four screws (callout 2), and then remove the motor.
- Remove drum motor 3: Disconnect one connector (callout 3), remove four screws (callout 4), and then remove the motor.

Figure 1-235 Remove the drum motor 2 or drum motor 3

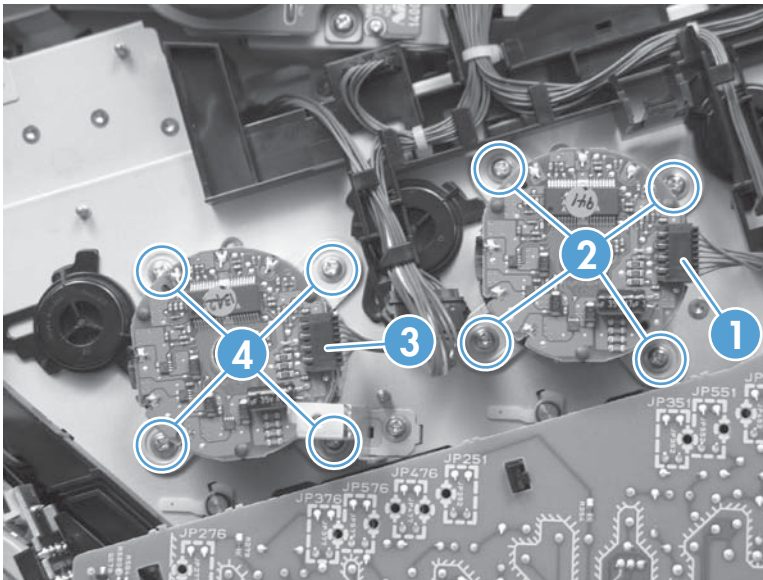

Fuser motor

Before proceeding, remove the following components:

- Toner-collection unit. See [Toner-collection unit on page 12](#).
- Right-rear cover. See [Right-rear cover on page 48](#).
- Left cover. See [Left cover on page 50](#).
- Rear-upper cover. See [Rear-upper cover on page 53](#).
- Rear cover. See [Rear cover on page 56](#).
- Formatter PCA. See [Formatter PCA on page 83](#).
- Interconnect board (ICB). See [Interconnect board \(ICB\) on page 88](#).
- DC controller. See [DC controller PCA and tray on page 91](#).
- Low-voltage power supply (LVPS). See [Low-voltage power supply \(LVPS\) on page 94](#).
- High-voltage power supply upper. See [High-voltage power supply upper on page 161](#).

Remove the fuser motor

Disconnect one connector (callout 1), remove three screws (callout 2), and then remove the motor.

Figure 1-236 Remove the fuser motor

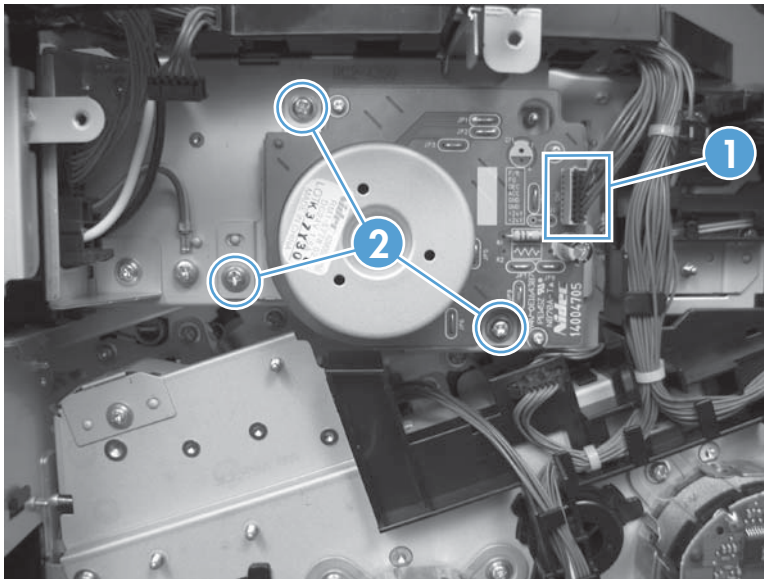

Main-drive assembly

Before proceeding, remove the following components:

- Toner-collection unit. See [Toner-collection unit on page 12](#).
- Intermediate transfer belt (ITB). See [Intermediate transfer belt \(ITB\) on page 24](#).
- Front-upper cover. See [Front-upper cover on page 42](#).
- Right-rear cover. See [Right-rear cover on page 48](#).
- Left cover. See [Left cover on page 50](#).
- Rear-upper cover. See [Rear-upper cover on page 53](#).
- Left-upper cover. See [Left-upper cover on page 54](#).
- Rear cover. See [Rear cover on page 56](#).
- Front-top cover. See [Front-top cover on page 69](#).
- Rear-top cover. See [Rear-top cover on page 71](#).
- Document feeder. See [Document feeder on page 73](#).
- Image scanner. See [Image scanner on page 77](#).
- Fuser. See [Fuser on page 81](#).
- Formatter PCA. See [Formatter PCA on page 83](#).
- Interconnect board (ICB). See [Interconnect board \(ICB\) on page 88](#).
- DC controller. See [DC controller PCA and tray on page 91](#).
- Low-voltage power supply (LVPS). See [Low-voltage power supply \(LVPS\) on page 94](#).
- Secondary transfer assembly. See [Secondary transfer assembly on page 112](#).
- Power-supply fan and fan duct. See [Power-supply fan and fan duct on page 121](#).
- High-voltage power supply lower. See [High-voltage power supply lower on page 129](#).
- High-voltage power supply upper. See [High-voltage power supply upper on page 161](#).

Remove the main-drive assembly

1. Remove two screws (callout 1), and then remove the cover (callout 2).

Figure 1-237 Remove the main-drive assembly (1 of 7)

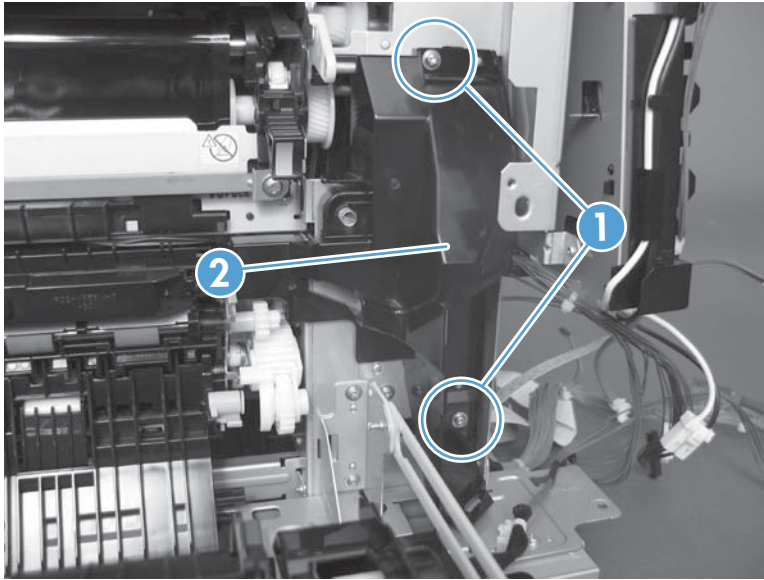

2. Release the wire harnesses from the guide (callout 3), and then remove one screw (callout 4).

Figure 1-238 Remove the main-drive assembly (2 of 7)

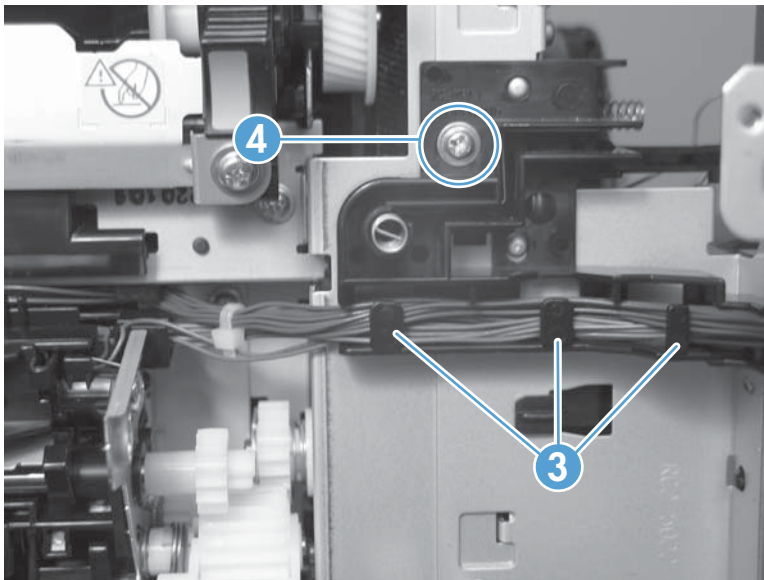

3. Lift the high-voltage bracket up to release it, and then remove the bracket.

Figure 1-239 Remove the main-drive assembly (3 of 7)

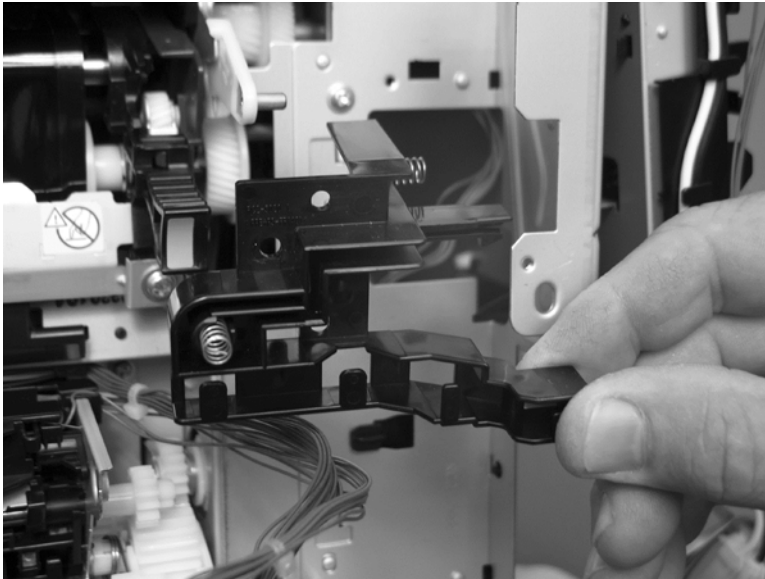

4. Disconnect seven connectors (callout 5), and then release the wire harnesses from the guides.

Figure 1-240 Remove the main-drive assembly (4 of 7)

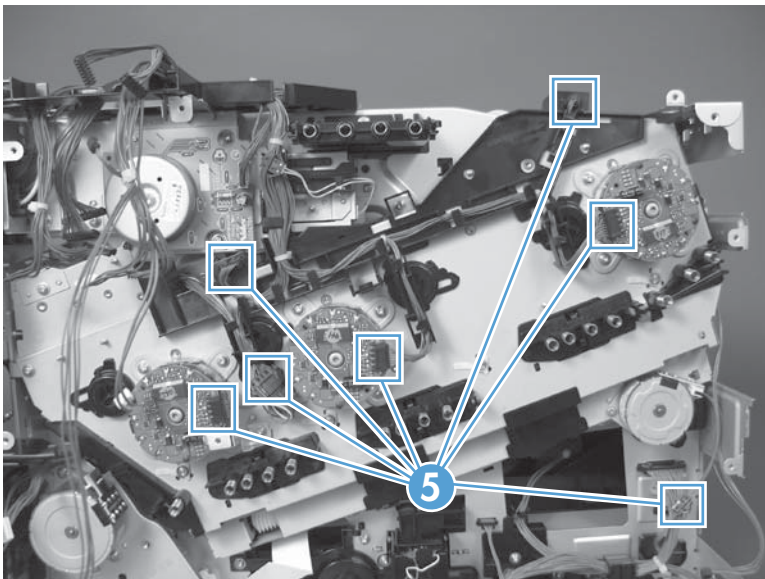

5. Remove two screws (callout 6), and then remove the sheet-metal plates (callout 7).

Figure 1-241 Remove the main-drive assembly (5 of 7)

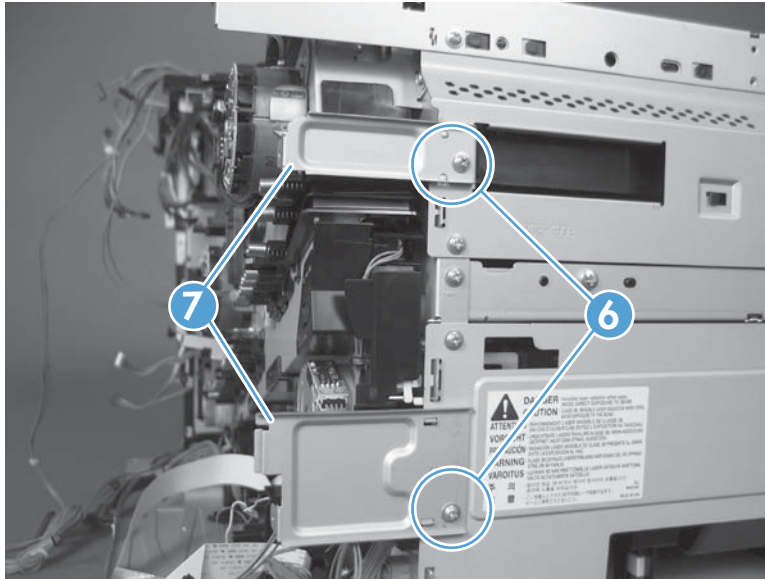

6. Release the FFCs and lower wiring harness from the guide, release one tab (callout 8), and then remove the guide.

Figure 1-242 Remove the main-drive assembly (6 of 7)

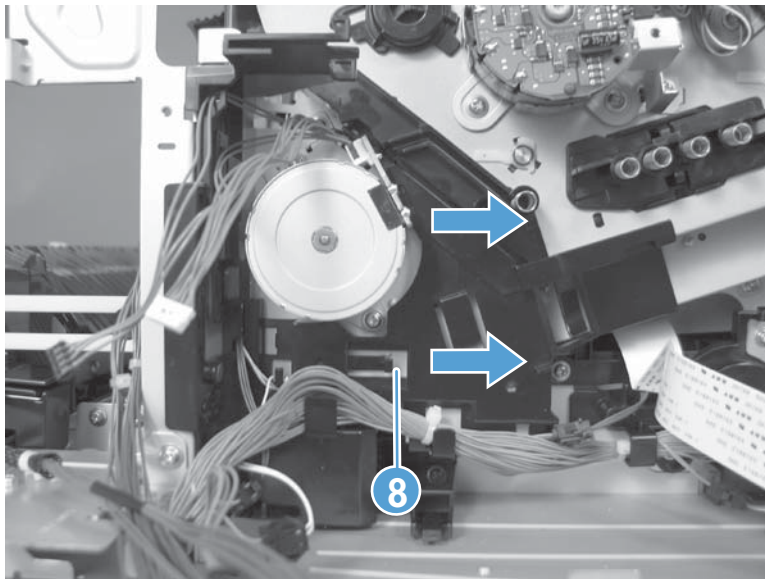

7. Remove ten screws (callout 9), and then carefully remove the assembly.

⚠ CAUTION: Be careful when you remove the assembly. The cams on the backside of the assembly can be dislodged. If the cams become dislodged, install them on the shafts as shown in [Figure 1-245 Reinstall the main-drive assembly \(2 of 11\) on page 173](#).

The black cam must be installed on the shaft furthest away from the developing-disengagement motor. The white cams are interchangeable.

Figure 1-243 Remove the main-drive assembly (7 of 7)

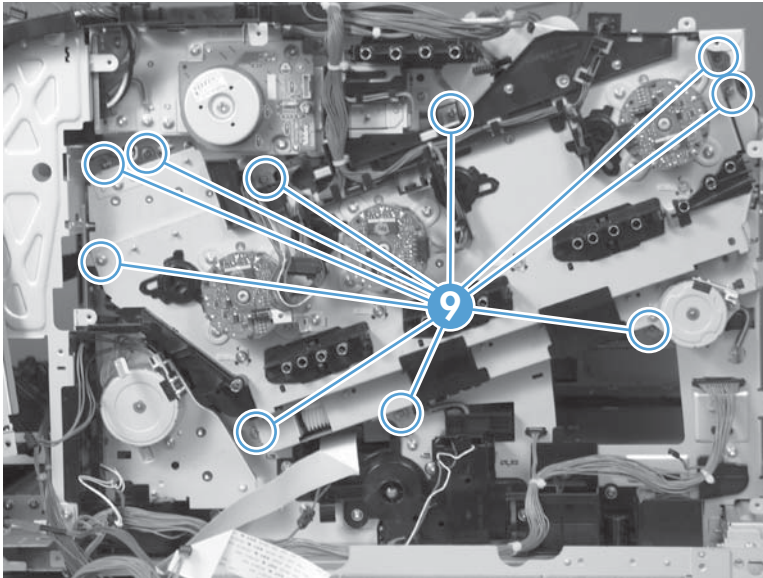

Reinstall the main-drive assembly

1. Remove the bracket (callout 1), two guides (callout 2), and the developing-disengagement motor (callout 3).

Install the bracket and guides on the replacement main-drive assembly.

 **NOTE:** Do not install the developing-disengagement motor on the assembly (this motor must be removed from the assembly to align the main-drive cams).

Figure 1-244 Reinstall the main-drive assembly (1 of 11)

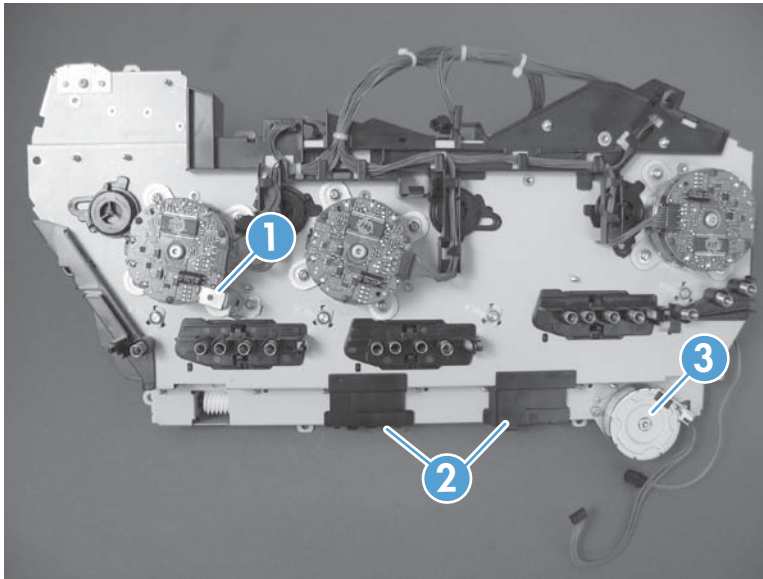

2. Locate the cams (callout 4) on the back side of the assembly.

Figure 1-245 Reinstall the main-drive assembly (2 of 11)

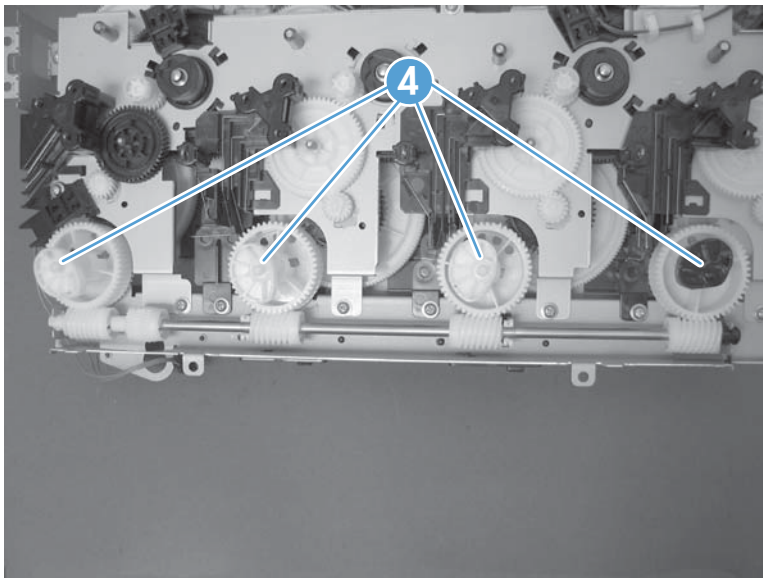

3. Slowly rotate the shaft near the black cam.

⚠ WARNING! Do not touch the plastic gears or cams. You must not wipe away any of the grease that is applied to these components. Always rotate the gears and cams by rotating the metal drive shaft.

Figure 1-246 Reinstall the main-drive assembly (3 of 11)

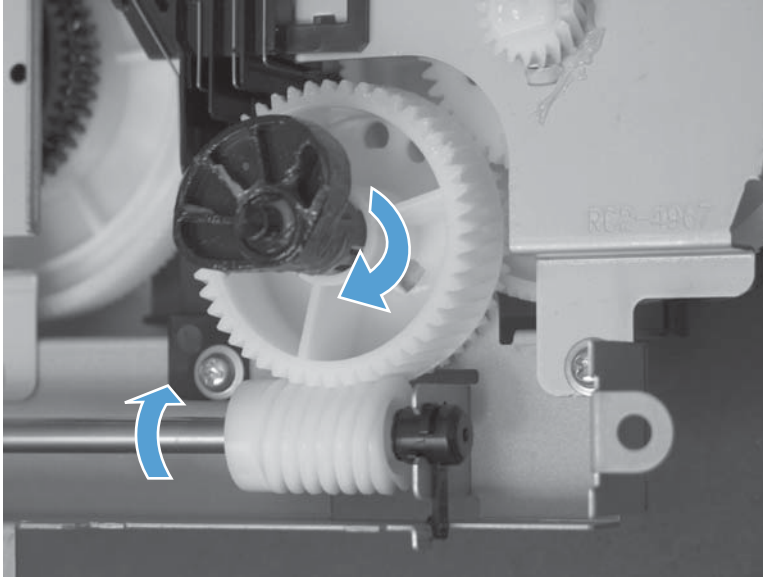

4. Continue to rotate the shaft until the holes in the black-cam gear align as shown below.

When correctly aligned, the *bottom-most* hole in the gear is aligned with a hole in the sheet-metal chassis.

📝 NOTE: The holes in the other cam gears have a different alignment. Make sure that the holes in the black-cam gear are correctly aligned.

Figure 1-247 Reinstall the main-drive assembly (4 of 11)

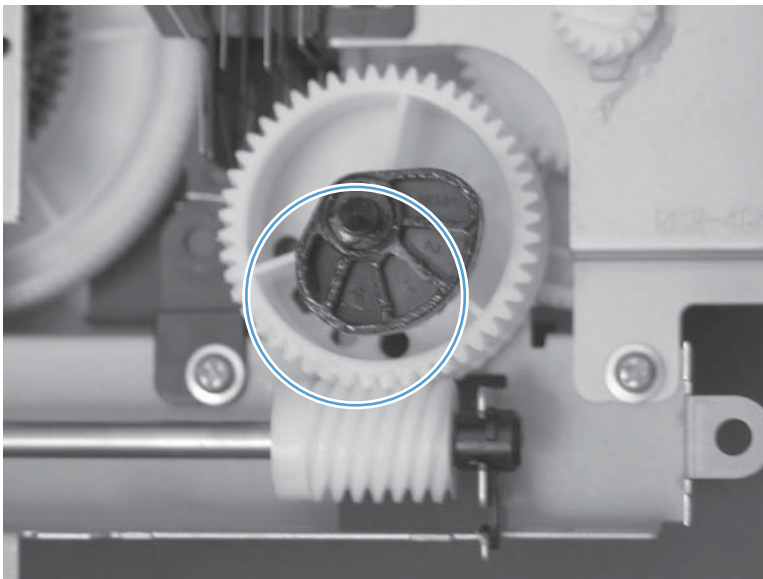

5. Verify that the cams (callout 5) align correctly.

 **TIP:** The second cam in from the right (the white cam to the left of the black cam), should have the *second* hole aligned with the hole in the sheet-metal chassis.

The third cam in from the right, should have the *third* hole aligned with the hole in the sheet-metal chassis.

The fourth cam in from the right (the cam nearest the developing-disengagement motor), should have the *fourth* hole aligned with the hole in the sheet-metal chassis.

If the second, third, or fourth cams do not correctly align, do the following. Hold the long drive shaft, and gently tilt the cam and gear away from the shaft to allow clearance to rotate the gear until the correct hole in the gear aligns with the hole in the chassis.

Figure 1-248 Reinstall the main-drive assembly (5 of 11)

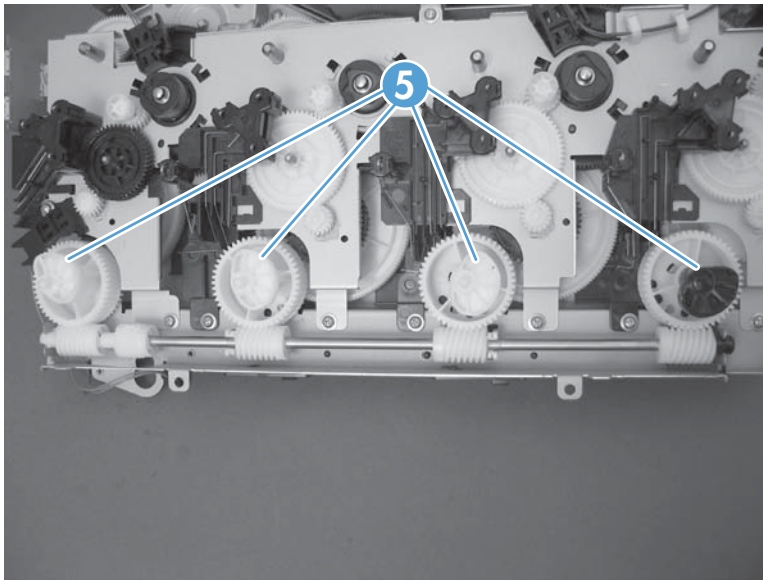

6. When the cams align correctly, they fit easily into the holes in the chassis.

Figure 1-249 Reinstall the main-drive assembly (6 of 11)

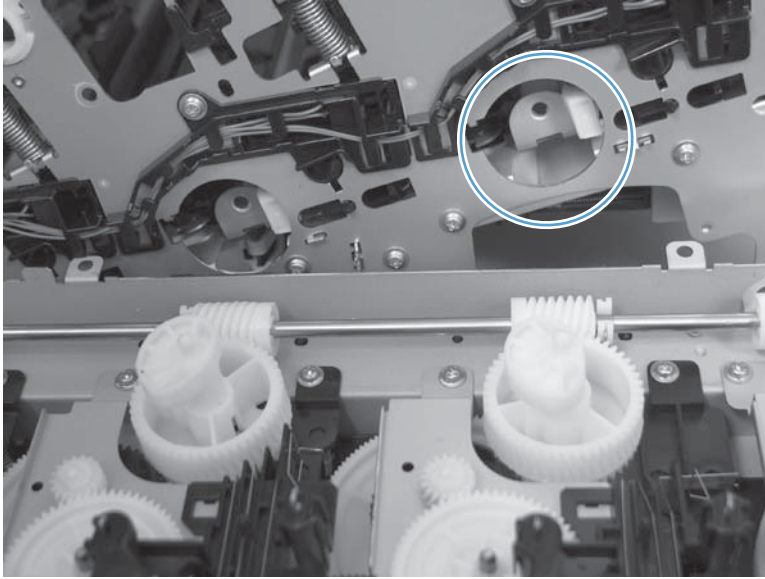

7. When the assembly is placed on the chassis, the pin on the swing gear and on the bracket (callout 6), must align with the holes in the chassis (callout 7).

Figure 1-250 Reinstall the main-drive assembly (7 of 11)

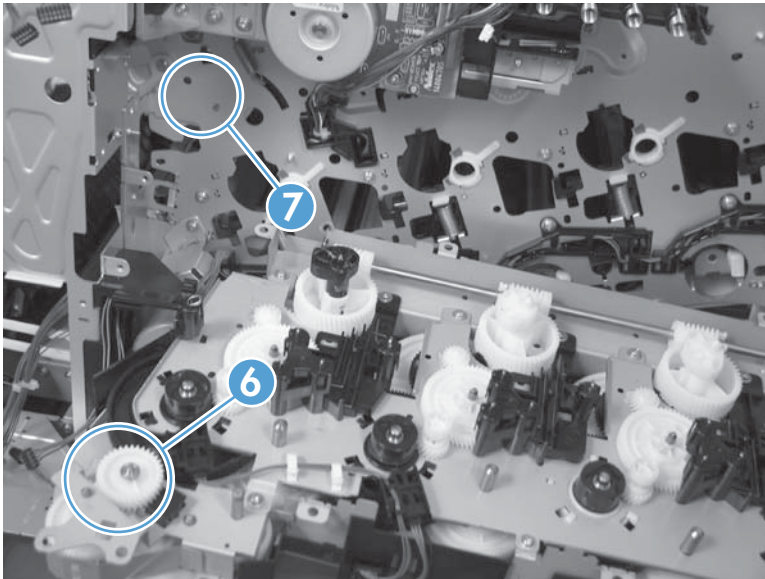

8. Position the assembly on the chassis.

Figure 1-251 Reinstall the main-drive assembly (8 of 11)

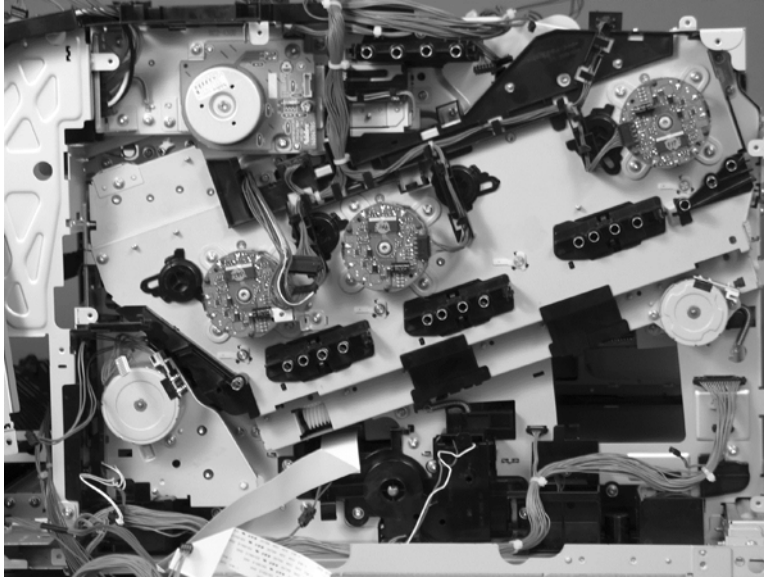

9. Use your finger to push in on the assembly, and use a small flat blade screwdriver to align the pin on the swing gear with the hole in the chassis.

Figure 1-252 Reinstall the main-drive assembly (9 of 11)

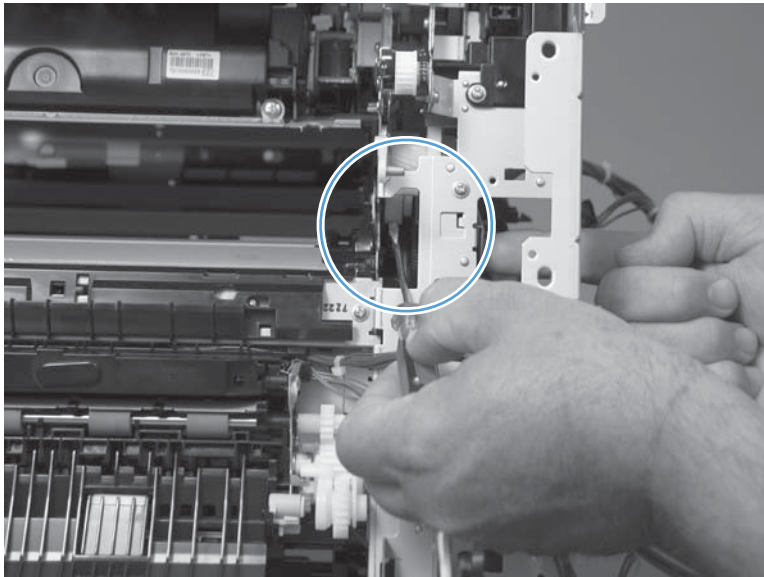

10. When the assembly is correctly installed against the chassis, the pin above the swing gear protrudes through the hole in the chassis.

Figure 1-253 Reinstall the main-drive assembly (10 of 11)

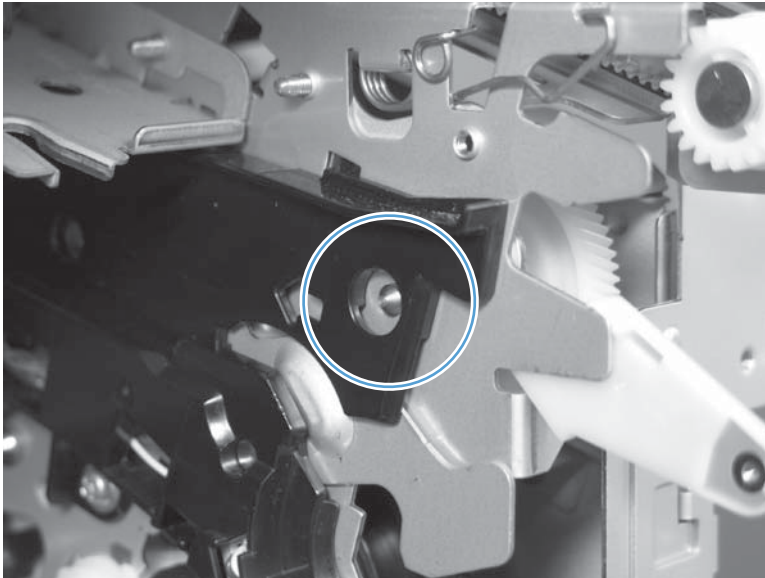

11. Install the main-drive assembly mounting screws, and then reinstall the developing-disengagement motor (callout 8).

Figure 1-254 Reinstall the main-drive assembly (11 of 11)

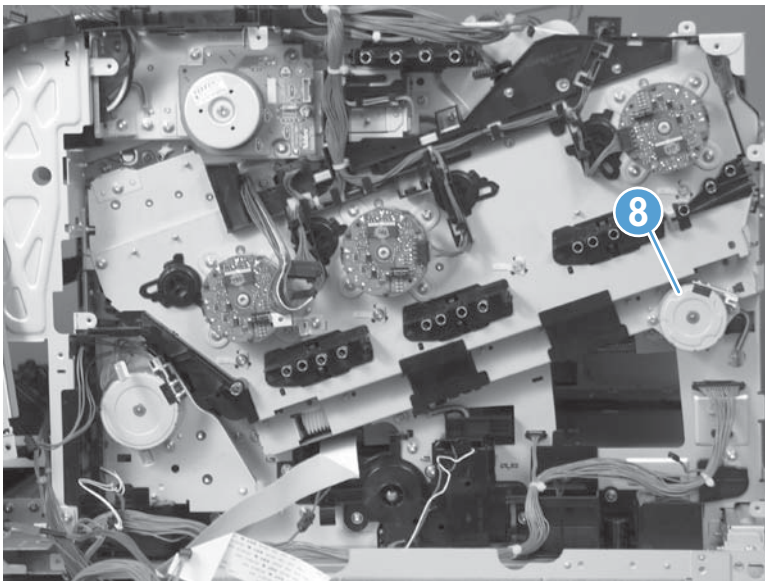

Fuser-drive assembly

Before proceeding, remove the following components:

- Toner-collection unit. See [Toner-collection unit on page 12](#).
- Intermediate transfer belt (ITB). See [Intermediate transfer belt \(ITB\) on page 24](#).
- Front-upper cover. See [Front-upper cover on page 42](#).
- Right-rear cover. See [Right-rear cover on page 48](#).
- Left cover. See [Left cover on page 50](#).
- Rear-upper cover. See [Rear-upper cover on page 53](#).
- Left-upper cover. See [Left-upper cover on page 54](#).
- Rear cover. See [Rear cover on page 56](#).
- Front-top cover. See [Front-top cover on page 69](#).
- Rear-top cover. See [Rear-top cover on page 71](#).
- Document feeder. See [Document feeder on page 73](#).
- Image scanner. See [Image scanner on page 77](#).
- Fuser. See [Fuser on page 81](#).
- Formatter PCA. See [Formatter PCA on page 83](#).
- Interconnect board (ICB). See [Interconnect board \(ICB\) on page 88](#).
- DC controller. See [DC controller PCA and tray on page 91](#).
- Low-voltage power supply (LVPS). See [Low-voltage power supply \(LVPS\) on page 94](#).
- Secondary transfer assembly. See [Secondary transfer assembly on page 112](#).
- Power-supply fan and fan duct. See [Power-supply fan and fan duct on page 121](#).
- High-voltage power supply lower. See [High-voltage power supply lower on page 129](#).
- High-voltage power supply upper. See [High-voltage power supply upper on page 161](#).
- Main-drive assembly. See [Main-drive assembly on page 168](#).

Remove the fuser-drive assembly

1. Disconnect one connector (callout 1), and then release the wire harnesses from the guide (callout 2).

Figure 1-255 Remove the fuser-drive assembly (1 of 6)

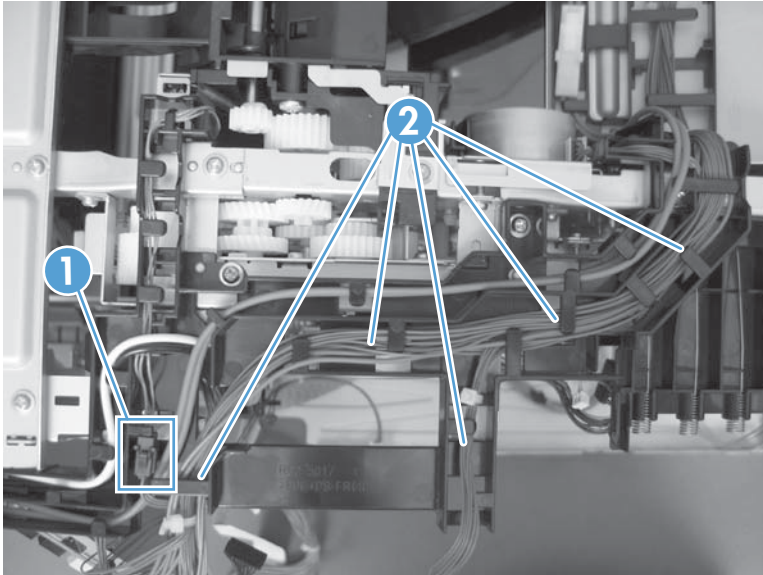

2. Remove two screws (callout 3), and then remove the guide (callout 4).

Figure 1-256 Remove the fuser-drive assembly (2 of 6)

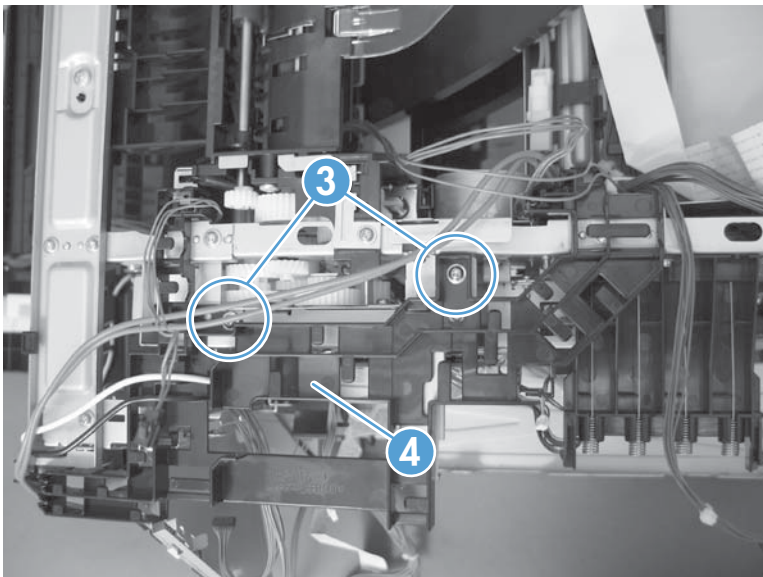

3. Remove one screw (callout 5), and then remove the sheet-metal plate (callout 6).

Figure 1-257 Remove the fuser-drive assembly (3 of 6)

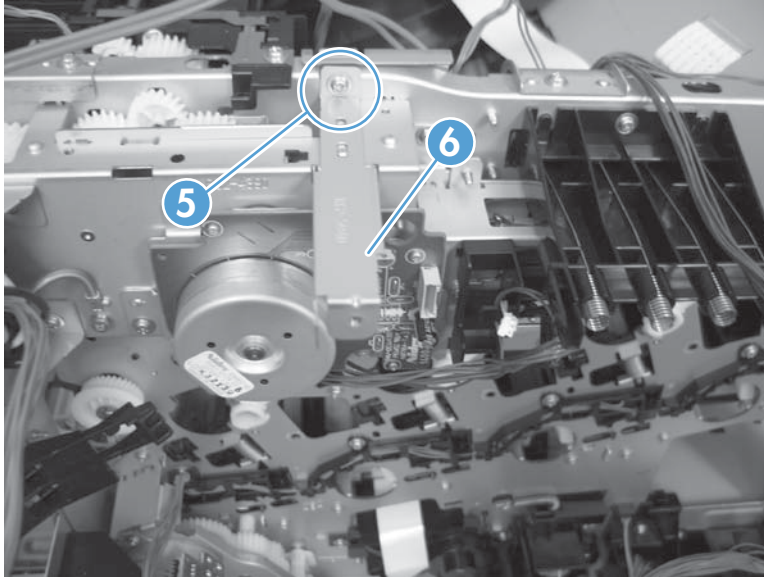

4. Remove one screw (callout 7), and then remove the cover (callout 8).

Figure 1-258 Remove the fuser-drive assembly (4 of 6)

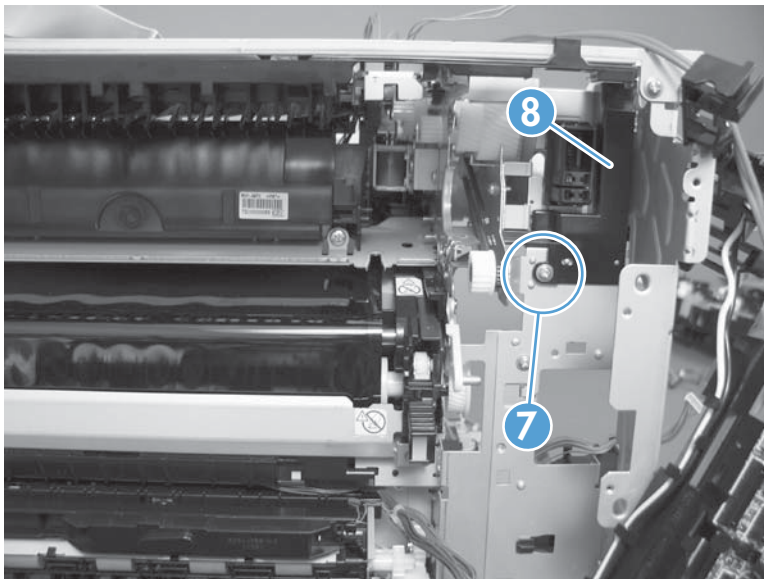

5. Remove five screws (callout 9).

Figure 1-259 Remove the fuser-drive assembly (5 of 6)

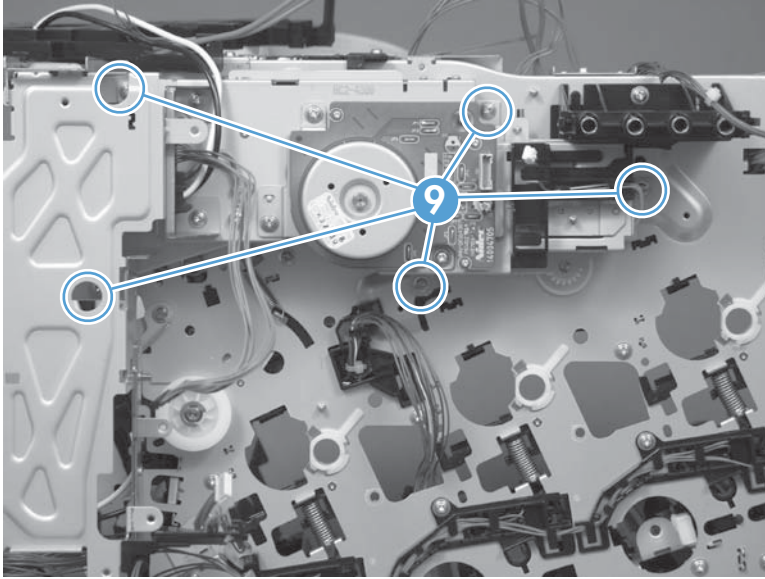

6. Carefully remove the assembly.

⚠ CAUTION: A gear on the assembly is not captive. Do not lose the gear when you remove the assembly. If the gear becomes dislodged, see [Reinstall the fuser-drive assembly on page 183](#).

Figure 1-260 Remove the fuser-drive assembly (6 of 6)

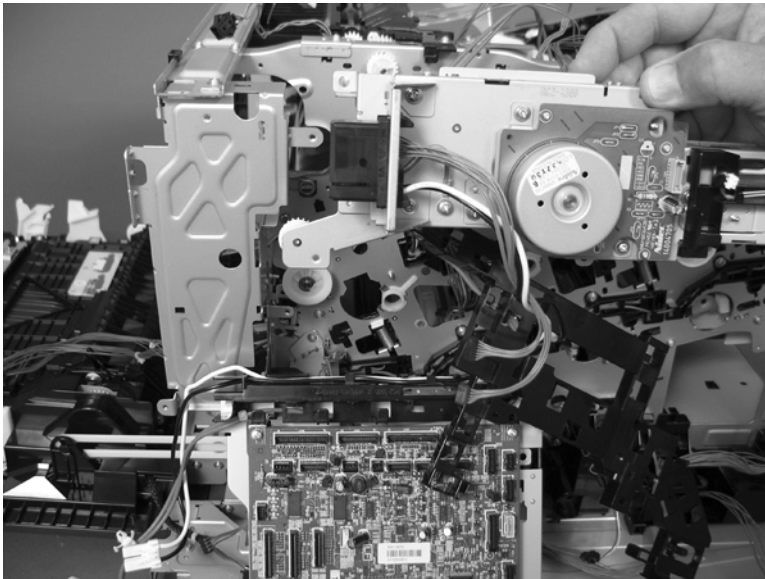

Reinstall the fuser-drive assembly

If the gear (callout 1) is dislodged when the assembly is removed, use the figure below to correctly install it on the assembly.

Figure 1-261 Reinstall the fuser-drive assembly

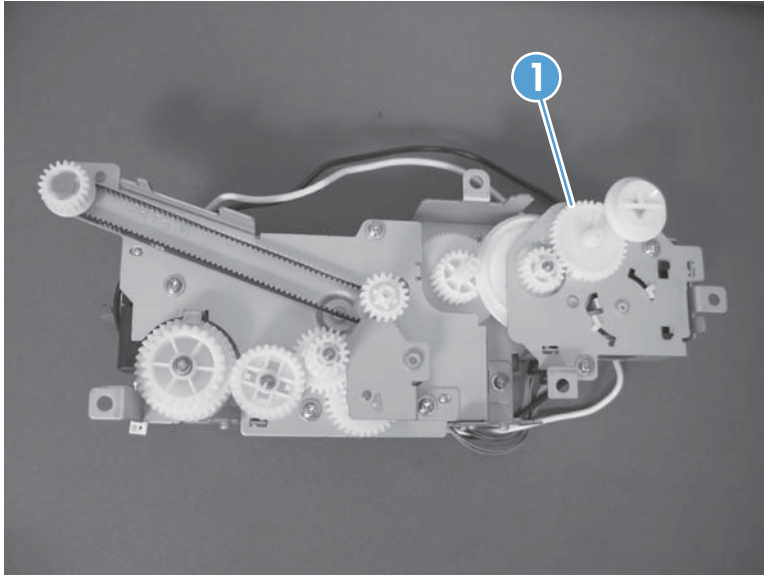

Delivery assembly

Before proceeding, remove the following components:

- Toner-collection unit. See [Toner-collection unit on page 12](#).
- Intermediate transfer belt (ITB). See [Intermediate transfer belt \(ITB\) on page 24](#).
- Front-upper cover. See [Front-upper cover on page 42](#).
- Left-upper cover. See [Left-upper cover on page 54](#).
- Right-rear cover. See [Right-rear cover on page 48](#).
- Left cover. See [Left cover on page 50](#).
- Rear-upper cover. See [Rear-upper cover on page 53](#).
- Rear cover. See [Rear cover on page 56](#).
- Front-top cover. See [Front-top cover on page 69](#).
- Rear-top cover. See [Rear-top cover on page 71](#).
- Document feeder. See [Document feeder on page 73](#).
- Image scanner. See [Image scanner on page 77](#).
- Fuser. See [Fuser on page 81](#).
- Formatter PCA. See [Formatter PCA on page 83](#).
- Interconnect board (ICB). See [Interconnect board \(ICB\) on page 88](#).
- DC controller. See [DC controller PCA and tray on page 91](#).
- Low-voltage power supply (LVPS). See [Low-voltage power supply \(LVPS\) on page 94](#).
- Secondary transfer assembly. See [Secondary transfer assembly on page 112](#).
- Power-supply fan and fan duct. See [Power-supply fan and fan duct on page 121](#).
- High-voltage power supply lower. See [High-voltage power supply lower on page 129](#).
- High-voltage power supply upper. See [High-voltage power supply upper on page 161](#).
- Main-drive assembly. See [Main-drive assembly on page 168](#).
- Fuser-drive assembly. See [Fuser-drive assembly on page 179](#).

Remove the delivery assembly

1. Remove two screws (callout 1), and then remove the guide (callout 2).

Figure 1-262 Remove the delivery assembly (1 of 5)

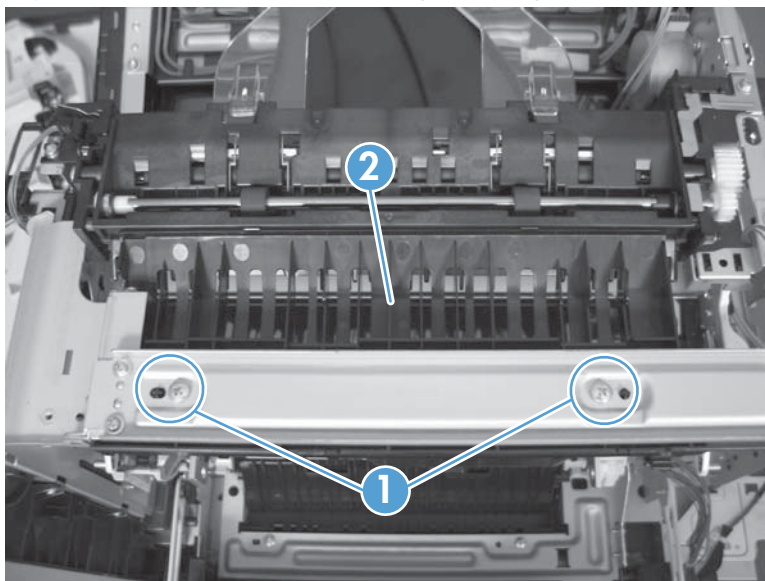

2. Remove two screws (callout 3).

Figure 1-263 Remove the delivery assembly (2 of 5)

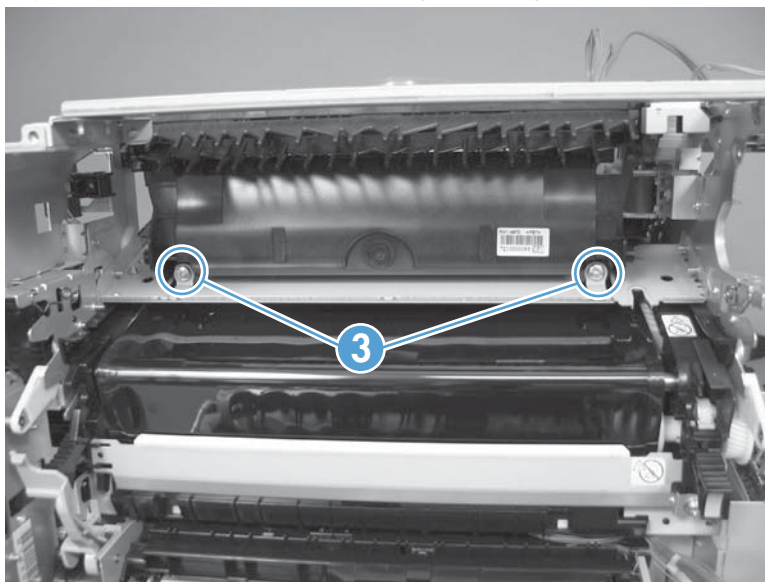

3. Release one tab (callout 4), and then remove the gear (callout 5).

Figure 1-264 Remove the delivery assembly (3 of 5)

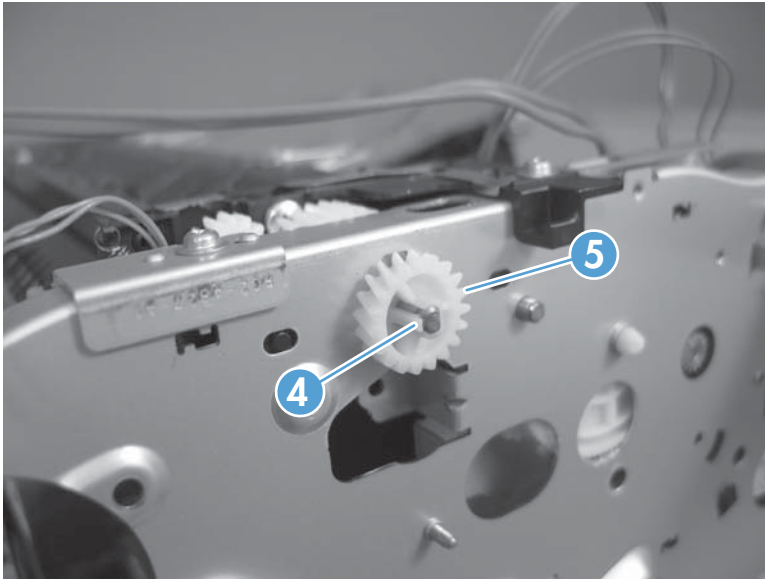

4. Release one tab (callout 6), and then rotate the locking clip until the tab on the clip aligns with the slot in the chassis.

Figure 1-265 Remove the delivery assembly (4 of 5)

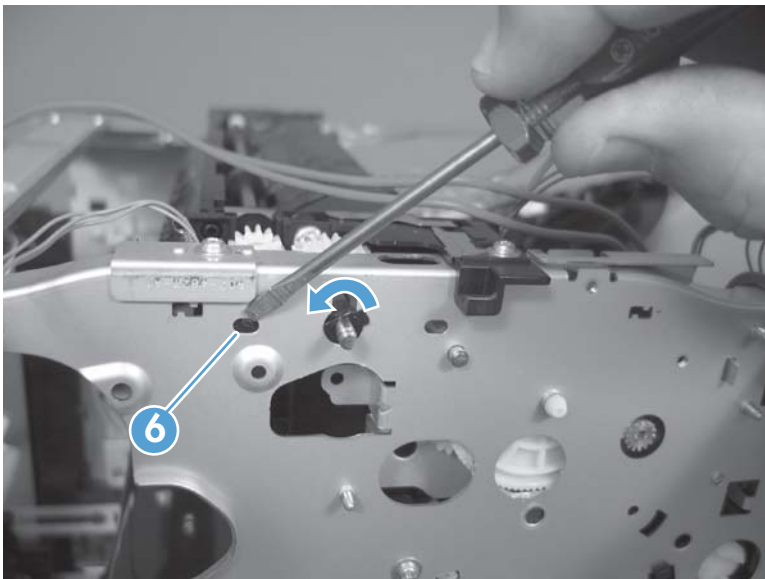

5. Disconnect one connector (callout 7), remove two screws (callout 8), and then carefully lift the assembly (callout 9) off of the product to remove it.

⚠ CAUTION: A solenoid arm (on the right side) and a spring (on the left side) on the assembly are not captive. Do not lose the solenoid arm or the spring when you remove the assembly. If the solenoid arm or spring become dislodged, see [Reinstall the delivery assembly on page 188](#).

Figure 1-266 Remove the delivery assembly (5 of 5)

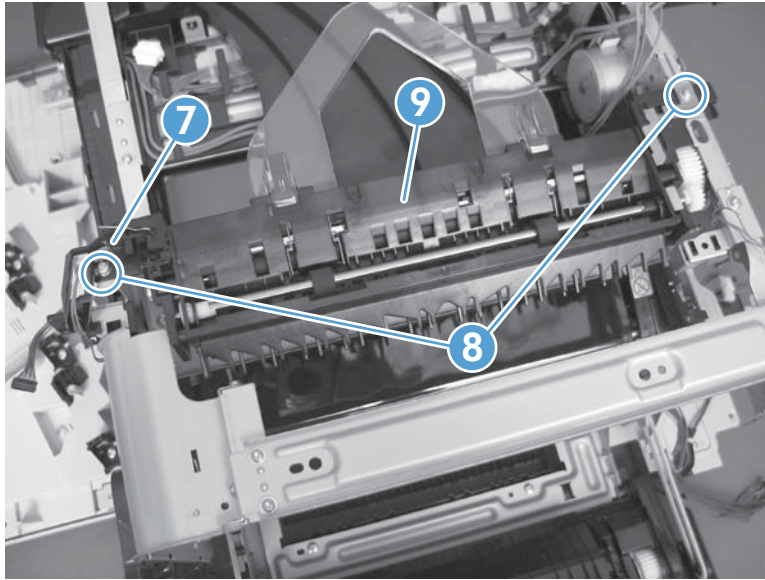

Reinstall the delivery assembly

1. Make sure that the solenoid arm is correctly installed on the assembly.

Figure 1-267 Reinstall the delivery assembly (1 of 2)

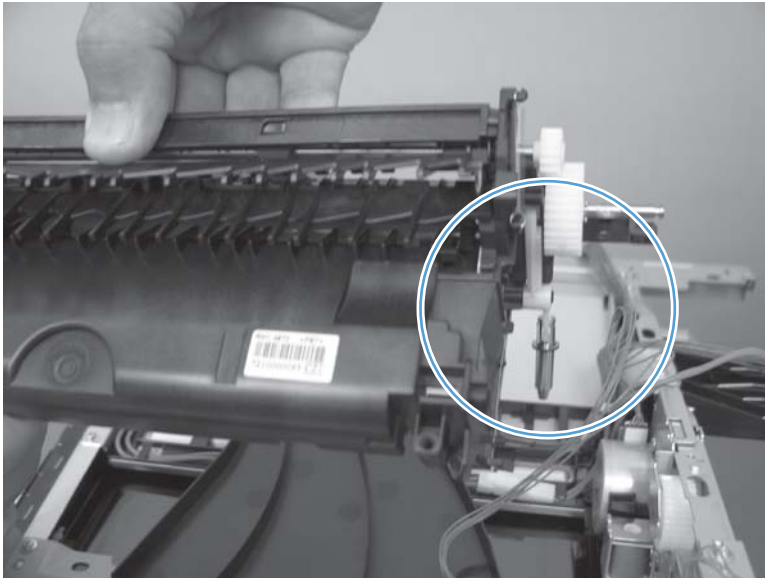

2. Make sure that the spring is correctly installed on the assembly.

Figure 1-268 Reinstall the delivery assembly (2 of 2)

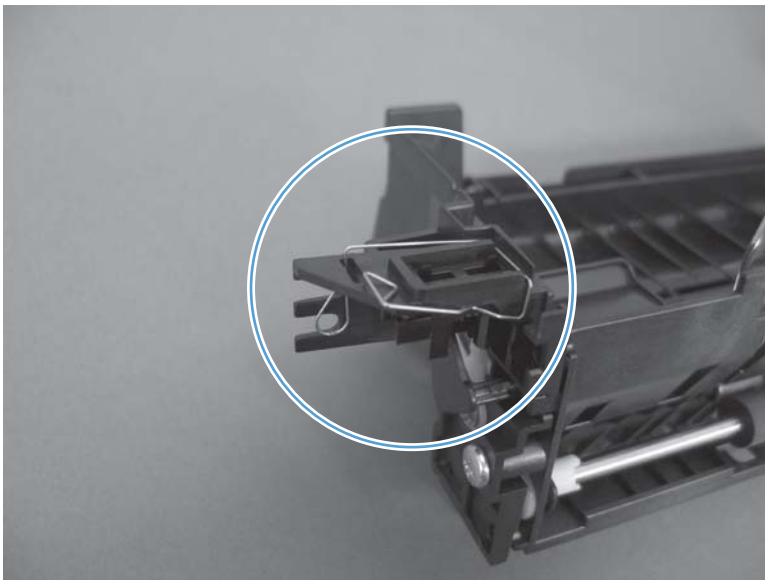

Duplex-drive assembly

Before proceeding, remove the following components:

- Toner-collection unit. See [Toner-collection unit on page 12](#).
- Intermediate transfer belt (ITB). See [Intermediate transfer belt \(ITB\) on page 24](#).
- Front-upper cover. See [Front-upper cover on page 42](#).
- Right-rear cover. See [Right-rear cover on page 48](#).
- Left cover. See [Left cover on page 50](#).
- Rear-upper cover. See [Rear-upper cover on page 53](#).
- Left-upper cover. See [Left-upper cover on page 54](#).
- Rear cover. See [Rear cover on page 56](#).
- Front-top cover. See [Front-top cover on page 69](#).
- Rear-top cover. See [Rear-top cover on page 71](#).
- Document feeder. See [Document feeder on page 73](#).
- Image scanner. See [Image scanner on page 77](#).
- Fuser. See [Fuser on page 81](#).
- Formatter PCA. See [Formatter PCA on page 83](#).
- Interconnect board (ICB). See [Interconnect board \(ICB\) on page 88](#).
- DC controller. See [DC controller PCA and tray on page 91](#).
- Low-voltage power supply (LVPS). See [Low-voltage power supply \(LVPS\) on page 94](#).
- Secondary transfer assembly. See [Secondary transfer assembly on page 112](#).
- Power-supply fan and fan duct. See [Power-supply fan and fan duct on page 121](#).
- High-voltage power supply lower. See [High-voltage power supply lower on page 129](#).
- High-voltage power supply upper. See [High-voltage power supply upper on page 161](#).
- Main-drive assembly. See [Main-drive assembly on page 168](#).
- Fuser-drive assembly. See [Fuser-drive assembly on page 179](#).
- Delivery assembly. See [Delivery assembly on page 184](#).

Remove the duplex-drive assembly

1. Disconnect two connectors (callout 1), and then remove three screws (callout 2).

Figure 1-269 Remove the duplex-drive assembly (1 of 2)

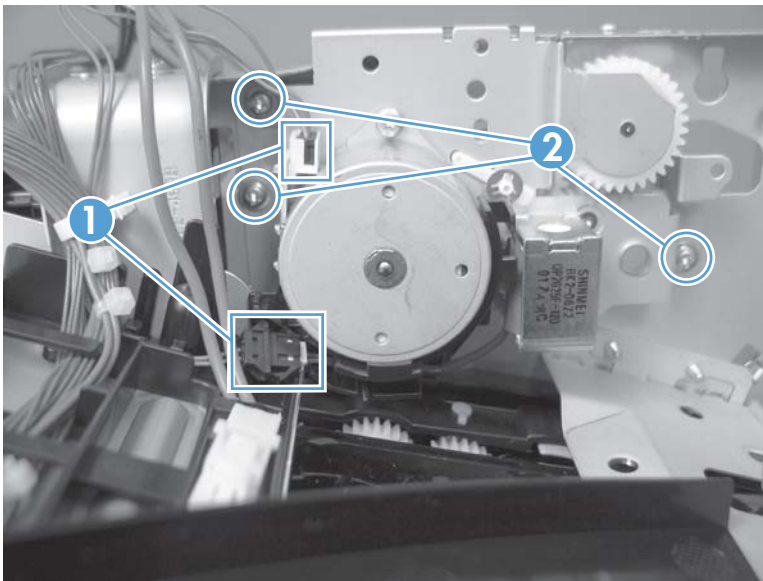

2. Remove the assembly.

Figure 1-270 Remove the duplex-drive assembly (2 of 2)

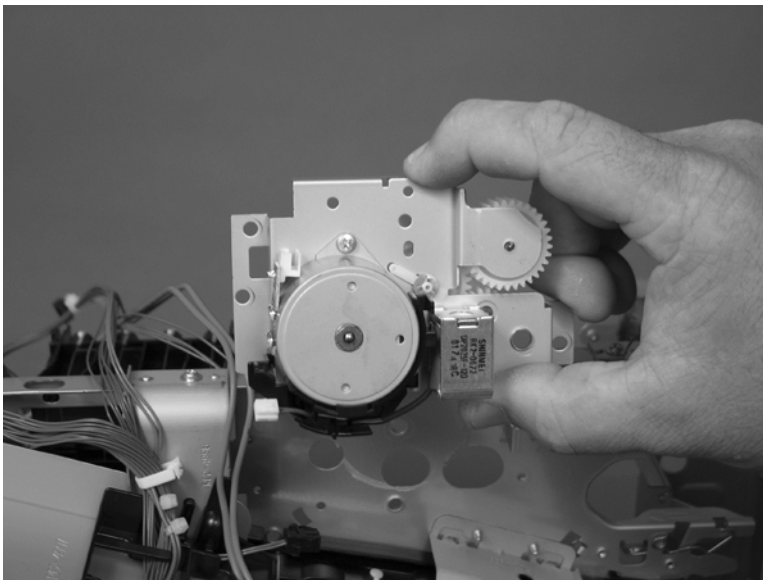

Optional paper feeder assembly (Tray 3)

 **NOTE:** For information about removing the Tray 3 pickup roller, see [Pickup and feed rollers \(Tray 3\) on page 19](#).

For information about removing the Tray 3, see [Tray 2 and 3 on page 14](#).

For information about removing the right door (optional paper feeder), see [Right door \(optional paper feeder\) on page 39](#).

Drawer connector

1. With a small screwdriver, lift one tab and then slide the drawer connector to release it.

Figure 1-271 Remove the drawer connector; optional paper feeder (1 of 2)

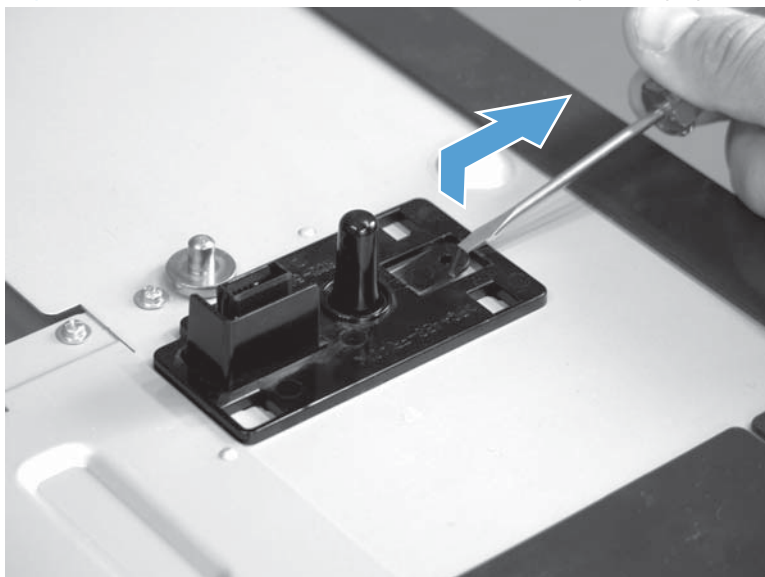

2. Remove one connector (callout 1).

Figure 1-272 Remove the drawer connector; optional paper feeder (2 of 2)

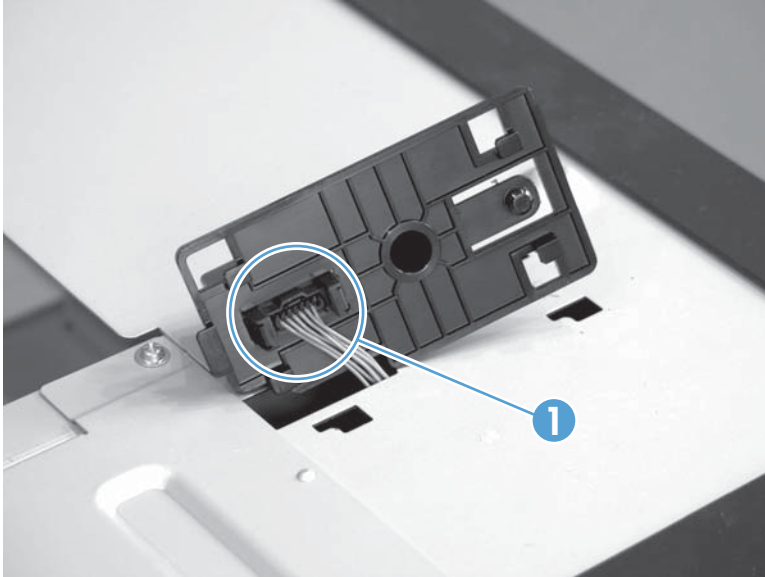

2 Parts and diagrams

- [Order parts, accessories, and supplies](#)
- [Orderable parts](#)
- [Whole unit replacement \(WUR\)](#)
- [Service parts](#)
- [Related documentation and software](#)
- [Fasteners used in this product](#)
- [How to use the parts lists and diagrams](#)
- [Assembly locations](#)
- [Covers](#)
- [Right-door assembly](#)
- [Internal assemblies](#)
- [Accessories](#)
- [Alphabetical parts list](#)
- [Numerical parts list](#)

Order parts, accessories, and supplies

You can obtain the following items directly from HP:

- **Replacement parts:** To order replacement parts in the U.S., go to www.hp.com/go/hpparts/. Outside the United States, order parts by contacting your local authorized HP service center.
- **Supplies and accessories:** To order supplies in the U.S., go to www.hp.com/go/ljsupplies. To order supplies worldwide, go to www.hp.com/ghp/buyonline.html. To order accessories, go to www.hp.com/support/lj500colorMFPM570.

Oderable parts

The following list of accessories was current at the time of printing. Ordering information and availability of the accessories might change during the life of the product.

Accessories

Table 2-1 Accessories

Item	Description	Product number	Part number
1 x 500-sheet paper feeder		CE084A	CF084-67901
LaserJet printer cabinet		CE085A	CD644-67917
Power cords	Accy Power Cord - EU		8121-0731
	Accy Power Cord - UK		8121-0739
	Accy Power Cord - DEN		8121-0733
	Accy Power Cord - RSA		8121-0737
	Accy Power Cord - SWI		8121-0738
	Accy Power Cord - ISR		8121-1004
	Accy Power Cord - AEC		8121-0734
	Accy Power Cord - AUS		8121-0837
	Accy Power Cord - IND		8121-0564
	Accy Power Cord - CHN		8121-0943
	Accy Power Cord - TAI		8121-0964
	Accy Power Cord - ARG		8121-0729
	Accy Power Cord - CHI		8121-0735
	Accy Power Cord - BRAZIL		8121-1071
	Accy Power Cord - AMS		8121-0740

Table 2-1 Accessories (continued)

Item	Description	Product number	Part number
Phone cords	RJ11 - 4 Wire Telecom Cable		8120-8922
	DEN Telecom Cable		8120-8911
	ISR Telecom Cable		8120-8913
	SWI Telecom Cable		8121-0844
	RJ11 - 2 Wire Telecom Cable		8121-0811
	KOR Telecom Cable		8120-8908
	AUS Telecom Cable		8120-8907
	NZ Telecom Cable		8120-8921
USB cable	1.83 m (6 ft)		8121-0868

Print cartridges and toner collection unit

Product name	Cartridge number	Part number (service)
HP Color LaserJet standard black print cartridge	CE400A	CE400-67901
HP Color LaserJet high capacity black print cartridge	CE400X	CE400-67902
HP Color LaserJet cyan print cartridge	CE401A	CE401-67901
HP Color LaserJet yellow print cartridge	CE402A	CE402-67901
HP Color LaserJet magenta print cartridge	CE403A	CE403-67901
Toner collection unit (TCU)	CE254A	RM1-4989-000CN
Fuser kit		CD644-67906 (110 V)
<ul style="list-style-type: none"> Fuser assembly (110 V or 220 V) Installation instructions Recycle guide 		CD644-67907 (220 V)

CAUTION: Make sure that you order the correct kit for the rated voltage of your product.

Customer self repair (CSR) and service kits

Product name	Part number
1 x 500-sheet paper feeder right door kit	CC468-67906
<ul style="list-style-type: none">• Right-door assembly• Right-door stopper• Right-door link• Installation instructions	
Duplex reverse guide kit	CC468-67913
<ul style="list-style-type: none">• Duplex reverse guide• Installation instructions	
Front-door assembly and name plate	CZ271-67901
<ul style="list-style-type: none">• Front-door assembly• HP Jewel• Name plate• Installation instructions	
Laser scanner assembly kit	CD644-67905
<ul style="list-style-type: none">• Laser/scanner assembly• Installation instructions	
Main drive assembly kit	CD644-67911
<ul style="list-style-type: none">• Main drive assembly• Installation instructions	
Tray 1 roller kit	CD644-67903
<ul style="list-style-type: none">• Separation pad• Pickup roller• Installation instructions	
Tray 2 - x roller kit)	CD644-67904
<ul style="list-style-type: none">• Separation roller assembly (Tray 2)• Kit, paper pickup roller assembly• Paper feed roller (1x500)• Paper pick up roller (1x500)• Installation instructions	

Product name	Part number
Secondary transfer (T2) roller kit <ul style="list-style-type: none"> • Secondary transfer roller assembly • Installation instructions 	CD644-67914
Intermediate transfer belt kit <ul style="list-style-type: none"> • Intermediate transfer belt • Secondary transfer roller assembly • Installation instructions 	CD644-67908
Toner collection unit (TCU) kit <ul style="list-style-type: none"> • Toner collection unit • Installation instructions 	CC468-67910
500-sheet feeder kit (Tray 3) <ul style="list-style-type: none"> • 500-sheet paper and HMT assembly 	CF084-67901
LJ printer cabinet kit <ul style="list-style-type: none"> • LJ printer cabinet 	CD644-67917
Spring separation pad kit <ul style="list-style-type: none"> • Spring separation pad • Installation instructions 	5851-4879

Whole unit replacement (WUR)

Table 2-2 LaserJet Pro 500 Color MFP M570dn (WUR)

LaserJet Pro 500 Color MFP M570dn	
M570dn 220V EMEA	CZ271-69001
M570dn 110V NAR/TW	CZ271-69002
M570dn 220V CL/AR/LAR	CZ271-69004
M570dn 110V BR	CZ271-67062

Table 2-3 LaserJet Pro 500 Color MFP M570dw (WUR)

LaserJet Pro 500 Color MFP M570dw	
M570dw 220V EMEA	CZ272-69001
M570dw 110V NAR/TW (TW only)	CZ272-69002
M570dw 220V AP/LAR (AP only)	CZ272-69003
M570dw 220V CN/MY	CZ272-67061

Service parts

The following service parts are not shown in the exploded view diagrams sections.

Table 2-4 Service parts

Item	Part number
Control panel	CZ271-60101
Control panel left mount	CZ271-40003
Control panel right mount	CZ271-40004
Control panel right rear	CZ271-40005
Control panel gear mount	CZ271-40015
Gear, control panel	CZ271-40006
Screw, friction gear mount	CZ271-20003
Washer, friction gear mount	CZ271-20004
Spring, friction gear mount	CZ271-20002
ICB Cable Guide	CZ271-40016
Cable, 24V	CZ271-50003
Cable, FAX	CF144-60126
Cable, FMTR power input	CZ271-50004
Cable, USB thumbdrive	CZ271-50005
Cable, VIF FFC A	CZ271-50007
Cable, VIF FFC B	CZ271-50008
Cable, wireless	CZ271-50006
USB mount plate	CZ271-01002
FAX PCA (AA; CF206A)	CF206-60001
FAX PCA (Euro; CF207A)	CF207-60001
FAX PCA (Brz; CF208A)	CF208-60001
Formatter	CZ272-60001
Wireless PCA	1150-7951
USB PCA	CF368A
Inter connect board (ICB)	CZ272-60002
Scanner/ADF assembly	CZ271-60017
Auto document feeder assembly	CZ271-60016
Scanner assembly	CZ271-60015
Scan bezel assembly	CZ271-60014

Table 2-4 Service parts (continued)

Item	Part number
ADF glass (with white background) assembly	CF286-60120
Scan base	CZ271-60013
Scanner chassis assembly	CF286-60112

Related documentation and software

Table 2-5 Related documentation and software

Item	Description	Part number
<i>HP LaserJet Pro 500 color MFP M570 Printer User Guide</i>	Product user guide	CZ271-90908
<i>HP LaserJet Pro 500 color MFP M570 Printer Service Repair Manual</i>	English service repair manual	CZ271-91020
<i>HP LaserJet Pro 500 color MFP M570 Printer Service Troubleshooting Manual</i>	English service troubleshooting manual	CZ271-91021

Fasteners used in this product





 **NOTE:** The screw illustrations in the following table are for reference only. Screws might vary in size and appearance from those shown in this table.

Table 2-6 Common fasteners

Example	Description	Size	Part Number
	Screw, tapping, truss head	M4X10	XB4-7401-005CN
	Screw, tapping, pan head	M4X10	XB4-7401-007CN
	Screw, D	M3X8	XA9-1671-000CN
	Screw, D	M3X8	XA9-1834-000CN
	Screw (formatter assembly)	M3X0.5	0515-4679

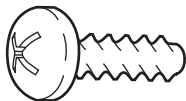
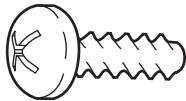
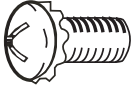
6 mm 8 mm 10 mm M 3 M 4
 

How to use the parts lists and diagrams

 **TIP:** Some assemblies that are unique to the LaserJet Pro 500 Color MFP M570dn or the LaserJet Pro 500 Color MFP M570dw are not shown in the following exploded view sections. To find part numbers for these assemblies, see [Service parts on page 200](#).

The figures in this chapter show the major subassemblies in the product and their component parts. A parts list table follows each exploded view assembly diagram. Each table lists the item number, the associated part number, and the description of each part. If a part is not listed in the table, then it is not a field replacement unit (FRU).

 **CAUTION:** Be sure to order the correct part. When looking for part numbers for electrical components, pay careful attention to the voltage that is listed in the description column. Doing so will ensure that the part number selected is for the correct all-in-one model.

 **NOTE:** In this manual, the abbreviation “PCA” stands for “printed circuit-board assembly.” Components described as a PCA might consist of a single circuit board or a circuit board plus other parts, such as cables and sensors.

Assembly locations

Base product (no optional trays or accessories)

Figure 2-1 Base product (no optional trays or accessories)

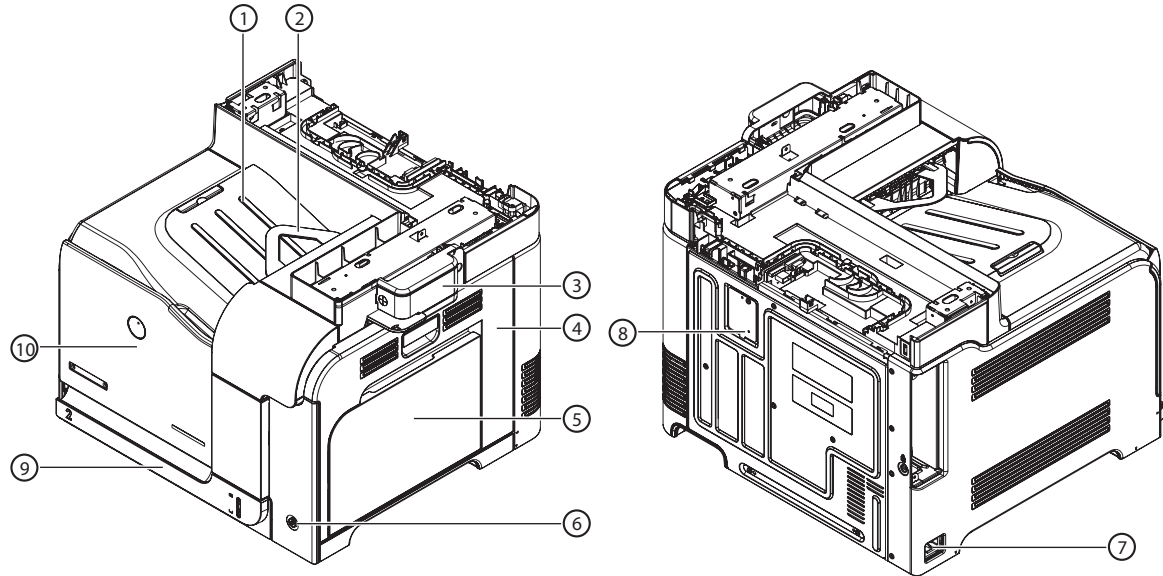

Item	Description	Item	Description
1	Face-down output bin	6	Power receptacle
2	Reverse tray	7	Test print switch
3	Right door	8	Tray 2
4	Tray 1	9	Front door
5	Power switch		

Base product (optional trays or accessories)

Figure 2-2 Base product (optional trays or accessories)

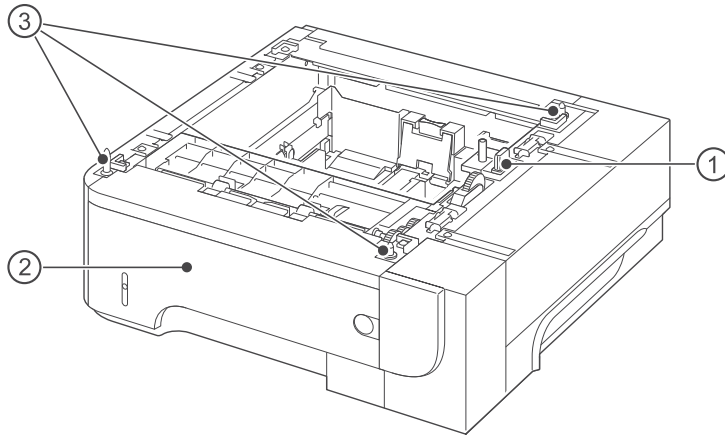

Table 2-7 Optional 500-sheet input tray

Item	Description
1	Connector
2	Tray 3
3	Positioning pins

Covers

Figure 2-3 External covers, panels, and doors

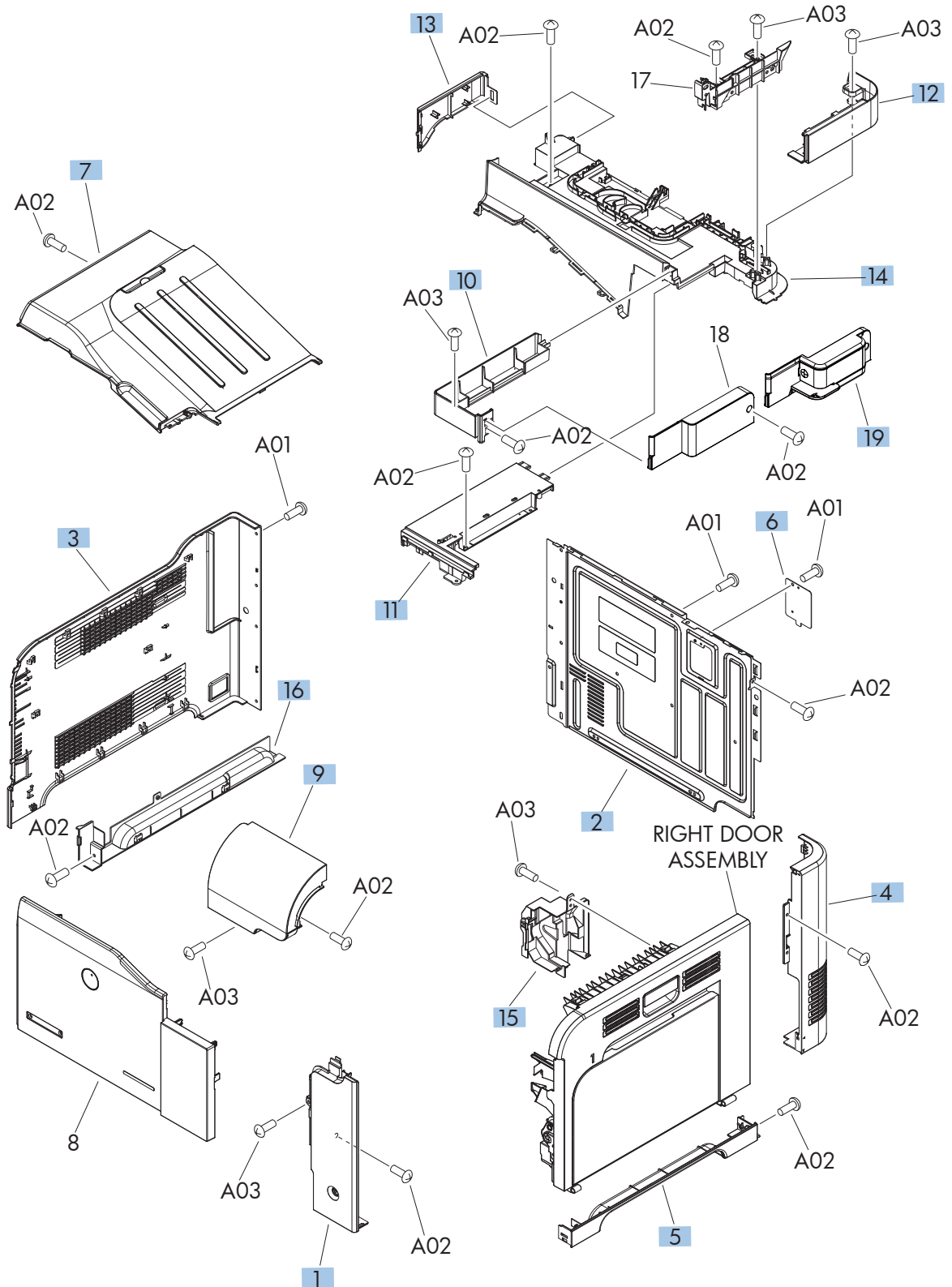

Table 2-8 External covers, panels, and doors

Ref	Description	Part number	Qty
1	Cover, right front	RC2-5056-000CN	1
2	Cover, rear	RC2-5048-000CN	1
3	Cover, left	RC2-5052-000CN	1
4	Cover, rear right	RC2-5057-000CN	1
5	Cover, right lower	RC2-5059-000CN	1
6	Plate, blanking	RC2-5938-000CN	1
7	Tray, paper delivery	RL1-1941-030CN	1
9	Control panel cover assembly	RM1-9198-000CN	1
10	Cover, right	RC3-2095-000CN	1
11	Cover, upper right	RC3-2093-000CN	1
12	Cover, right rear	RC3-2096-000CN	1
13	Cover, left rear	RC3-2094-000CN	1
14	Cover, upper rear	RC3-2092-000CN	1
15	Cover, right door gear rear	RC2-4924-000CN	1
16	Cover, left lower	RC2-5069-000CN	1

Right-door assembly

Figure 2-4 Right-door assembly

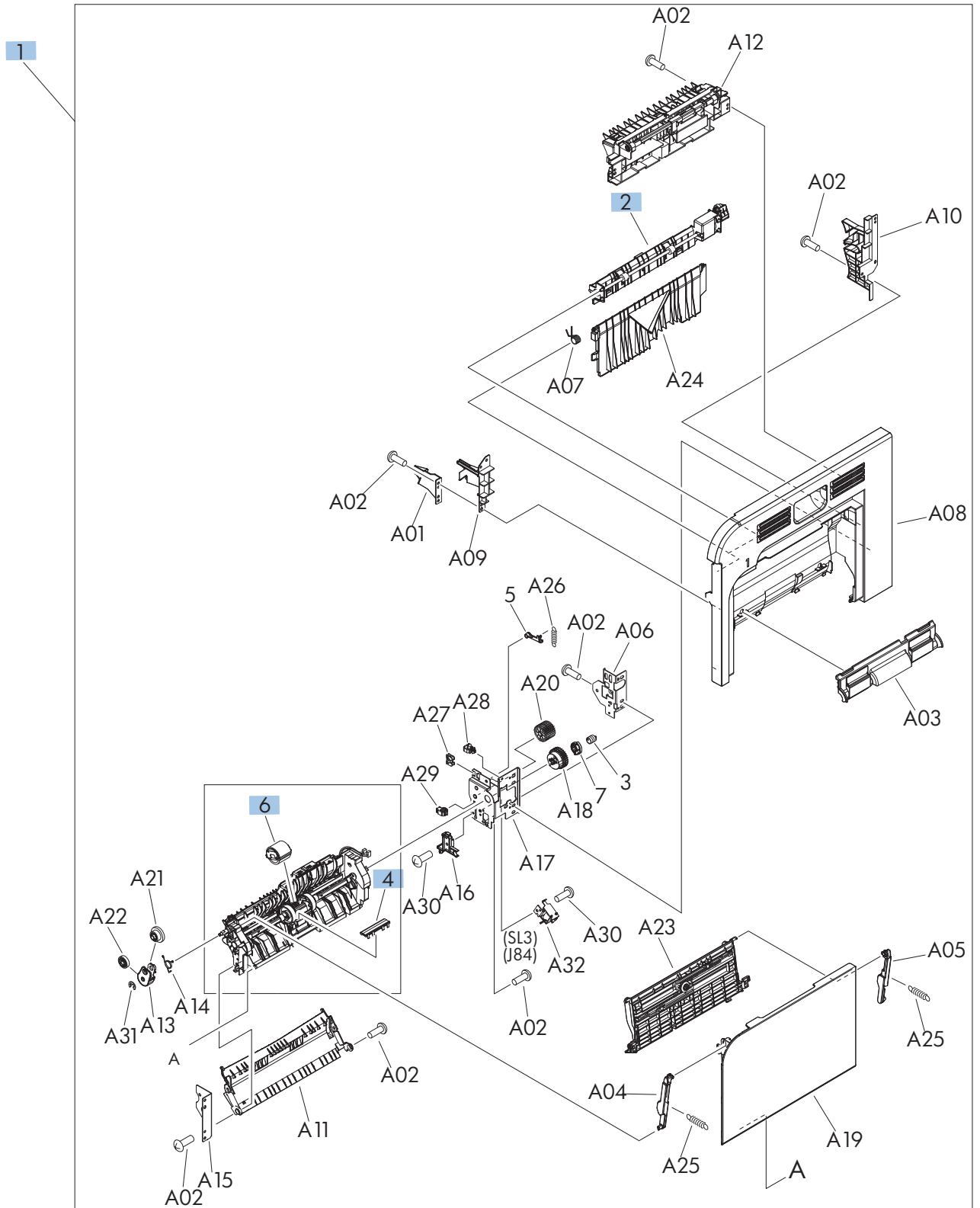

Table 2-9 Right-door assembly

Ref	Description	Part number	Qty
1	Right door assembly	RM1-8123-000CN	1
2	Duplex paper feed assembly	RM1-4959-000CN	1

Internal assemblies

Internal assemblies (1 of 6)

Figure 2-5 Internal assemblies (1 of 6)

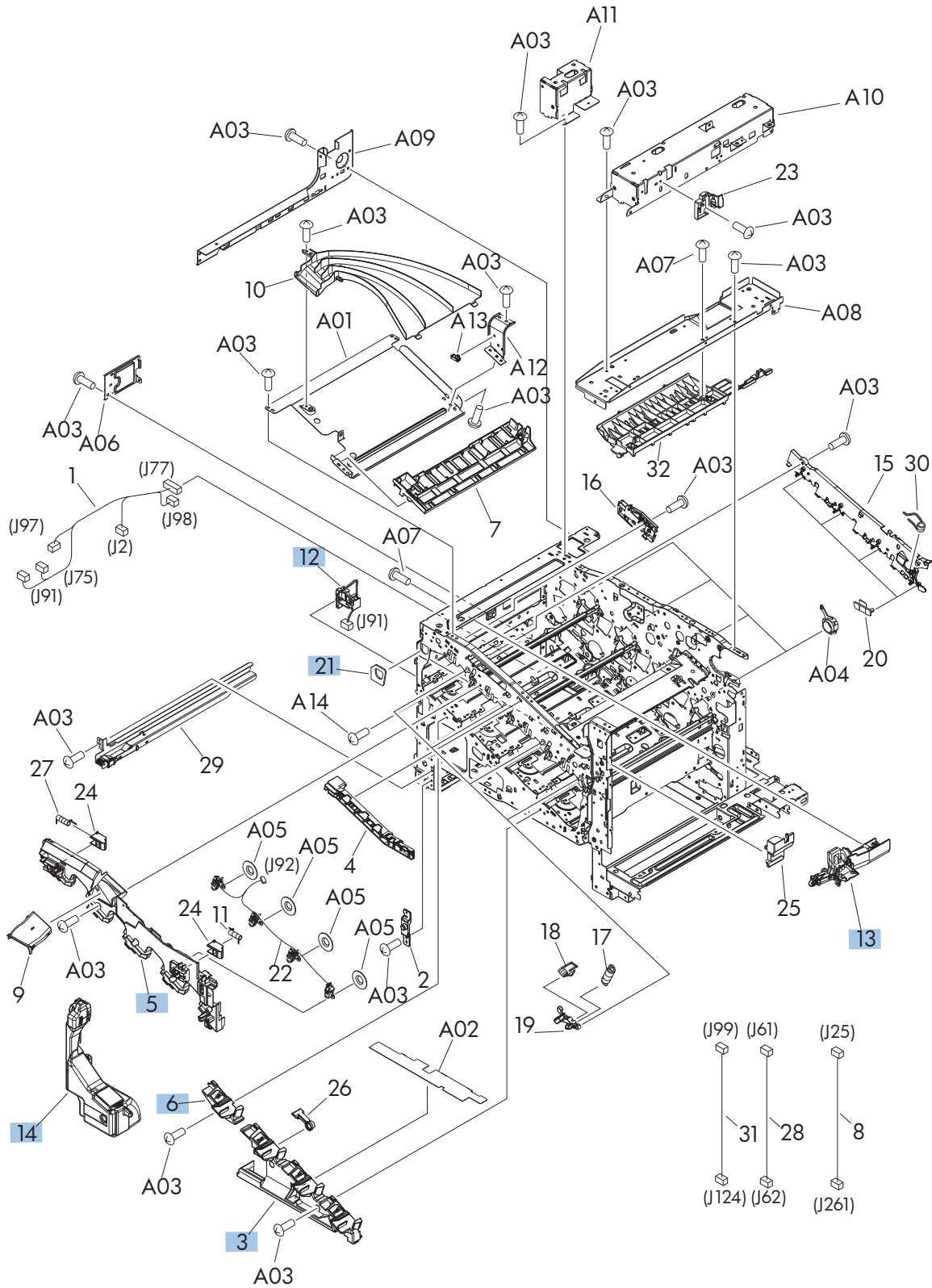

Table 2-10 Internal assemblies (1 of 6)

Ref	Description	Part number	Qty
3	Cover, front inner lower unit	RL1-1914-020CN	1
5	Cover, front inner upper	RC3-1070-000CN	1
6	Cover, front inner lower	RL1-1915-000CN	1
12	Waste toner detect assembly	RM1-5696-000CN	1
13	Waste toner duct assembly	RM1-8138-000CN	1
14	Toner collection unit (TCU)	RM1-4989-000CN	1
21	Waste toner box seal	RC2-4780-000CN	4

Internal assemblies (2 of 6)

Figure 2-6 Internal assemblies (2 of 6)

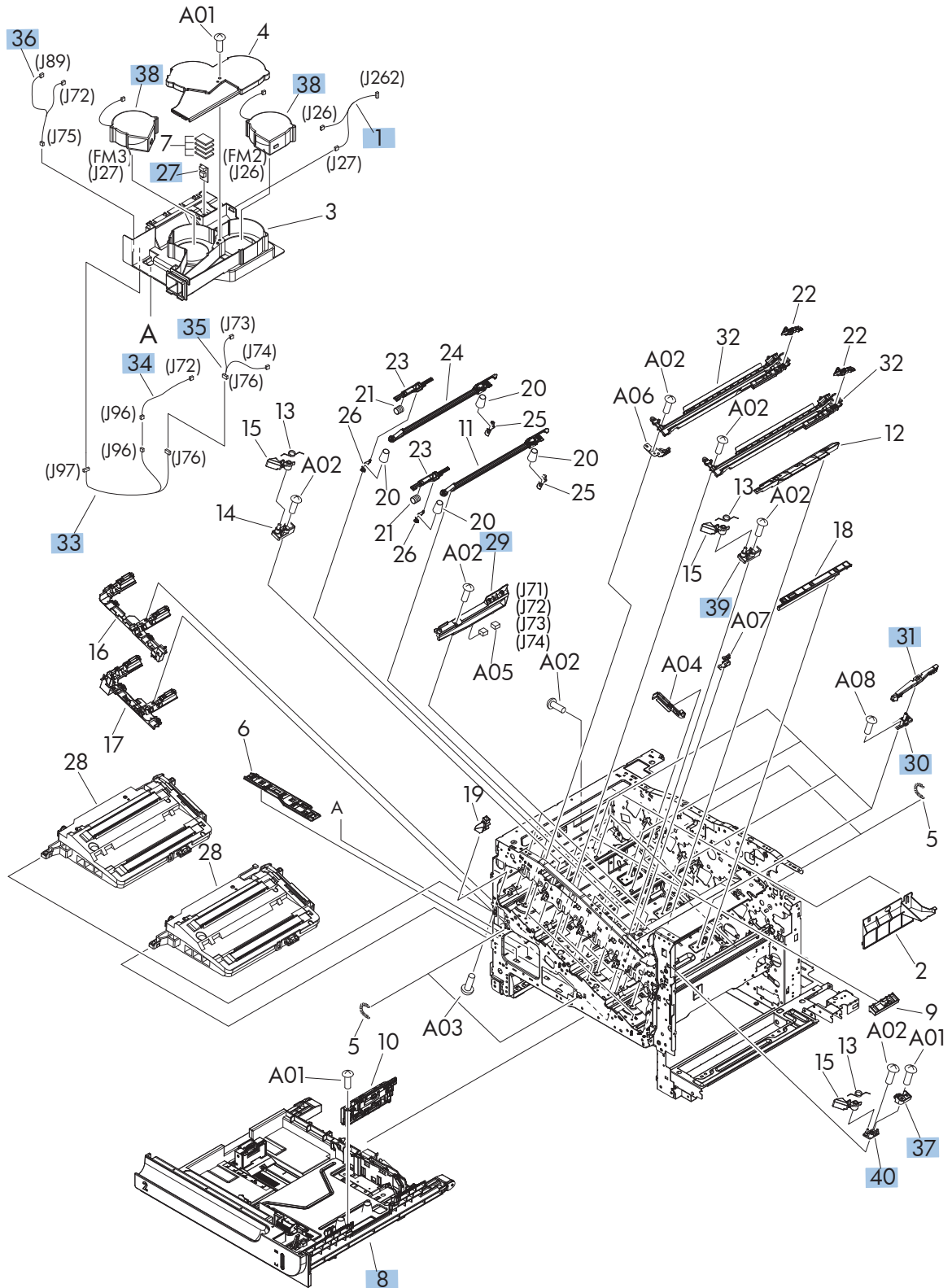

Table 2-11 Internal assemblies (2 of 6)

Ref	Description	Part number	Qty
1	Fan cable assembly	RM1-5746-000CN	1
8	Tray 2	RM1-4962-060CN	1
27	Temperature sensor unit	RK2-3267-000CN	1
29	Toner sensor holder assembly	RM1-5700-000CN	4
30	Stand assembly	RM1-5588-000CN	4
31	Base assembly	RM1-8149-000CN	4
33	Connecting cable assembly	RM1-5749-000CN	1
34	Sensor cable assembly	RM1-5740-000CN	1
35	Sensor cable assembly	RM1-5741-000CN	1
36	Motor/sensor cable assembly	RM1-5752-000CN	1
37	Cartridge lock lever holder	RC2-5957-000CN	1
38	Fan (FM2, FM3)	RK2-2418-000CN	2
39	Cartridge lock lever holder	RC3-1075-000CN	2
40	Cartridge lock lever holder	RC2-5956-000CN	2

Internal assemblies (3 of 6)

Figure 2-7 Internal assemblies (3 of 6)

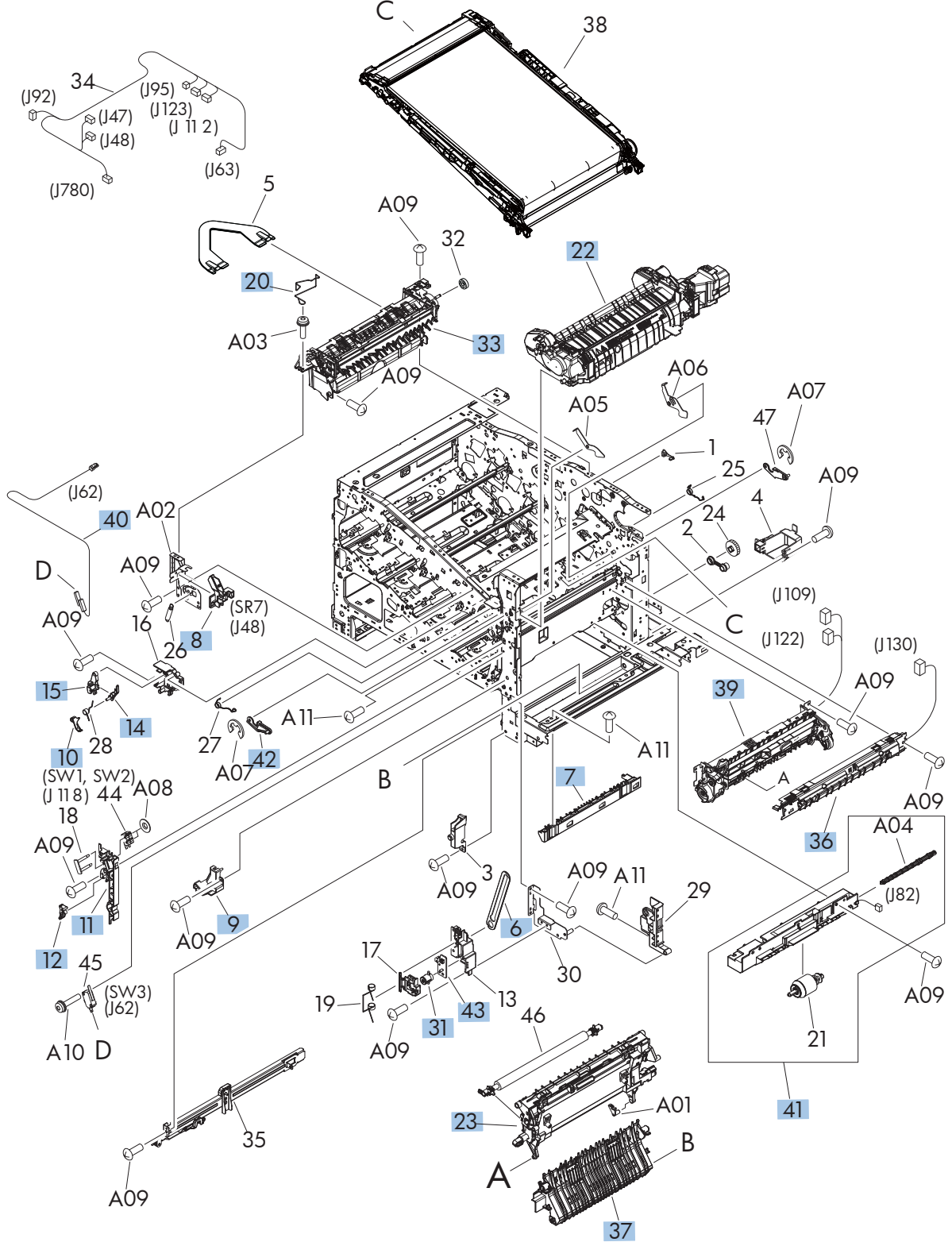

Table 2-12 Internal assemblies (3 of 6)

Ref	Description	Part number	Qty
6	Link, door stopper	RC2-4916-000CN	1
7	Guide, option entrance	RC2-4915-000CN	1
8	Sensor cable guide assembly (SR7)	RM1-8178-000CN	1
9	Cover, inner right lower	RC2-5019-000CN	1
10	Link, interlock (SW1)	RC2-5120-000CN	1
11	Mount, interlock switch	RC2-5123-000CN	1
12	Arm, interlock link switch	RC2-5121-000CN	1
14	Link, interlock	RC2-5119-000CN	1
15	Link, interlock	RC2-5118-000CN	1
20	Wire (mech) sensor project	RC2-4828-000CN	1
22	Fuser (110V)	RM1-8154-000CN	1
22	Fuser (220V)	RM1-8156-000CN	1
23	Secondary transfer assembly	RM1-4952-030CN	1
31	Button, power supply	RL1-1947-000CN	1
33	Paper delivery assembly	RM1-4970-060CN	1
36	Density detect assembly	RM1-8163-000CN	1
37	Pick up lower guide assembly	RM1-9192-000CN	1
39	Registration assembly	RM1-4969-000CN	1
40	Switch cable assembly	RM1-8065-000CN	1
41	Paper pick up assembly	RM1-4967-000CN	1
42	Front lock arm assembly	RM1-5532-000CN	1
43	Switch PCA assembly	RM1-8097-000CN	1

Internal assemblies (4 of 6)

Figure 2-8 Internal assemblies (4 of 6)

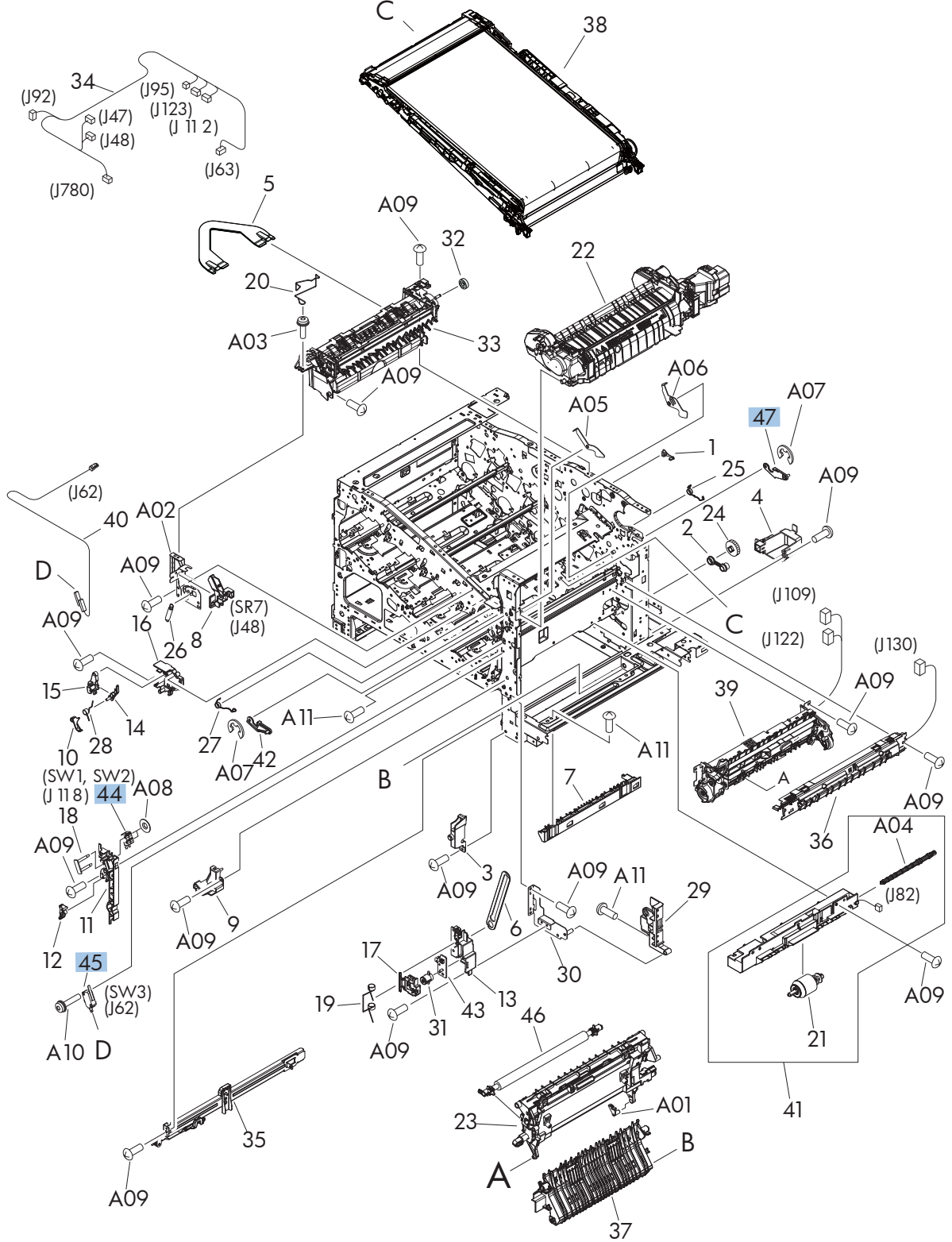

Table 2-13 Internal assemblies (4 of 6)

Ref	Description	Part number	Qty
44	Door switch assembly (SW2)	RM1-5732-000CN	1
45	Microswitch (SW3)	WC4-5171-000CN	1
47	Rear lock arm assembly	RM1-5533-000CN	1

Internal assemblies (5 of 6)

Figure 2-9 Internal assemblies (5 of 6)

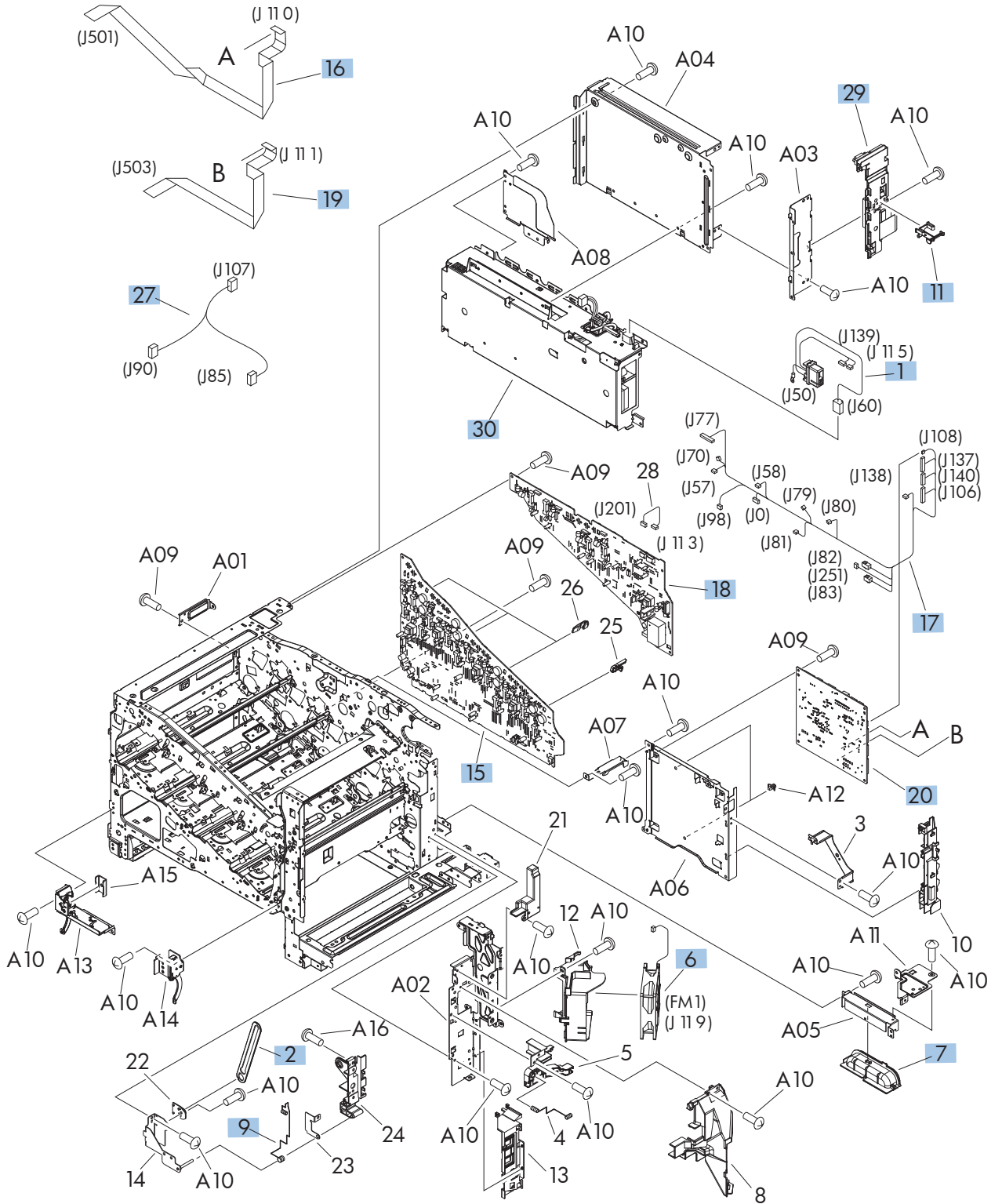

Table 2-14 Internal assemblies (5 of 6)

Ref	Description	Part number	Qty
1	Fusing connecting cable assembly	RM1-5714-000CN	1
2	Link, door stopper	RC2-4916-000CN	1
6	Fan (FM1)	RK2-2416-000CN	1
7	Rear handle	RC2-5042-000CN	1
9	Spring, grounding	RC2-5148-000CN	1
11	Switch arm	RC2-5943-000CN	1
15	Lower HVPS (D)	RM1-8087-000CN	1
16	Cable, laser FCC 1	RK2-3941-000CN	1
17	Cable, rear assembly	RM1-8084-000CN	1
18	Upper HVPS (T)	RM1-8088-000CN	1
19	Cable, laser FCC 2	RK2-3943-000CN	1
20	DC Controller	RM1-8119-000CN	1
27	Cable, MP sensor assembly	RM1-5737-000CN	1
29	Interconnect PCA (ICB)	CZ272-60002	1
30	LVPS (110V)	RM1-8102-000CN	1
30	LVPS (220V)	RM1-8103-000CN	1

Internal assemblies (6 of 6)

Figure 2-10 Internal assemblies (6 of 6)

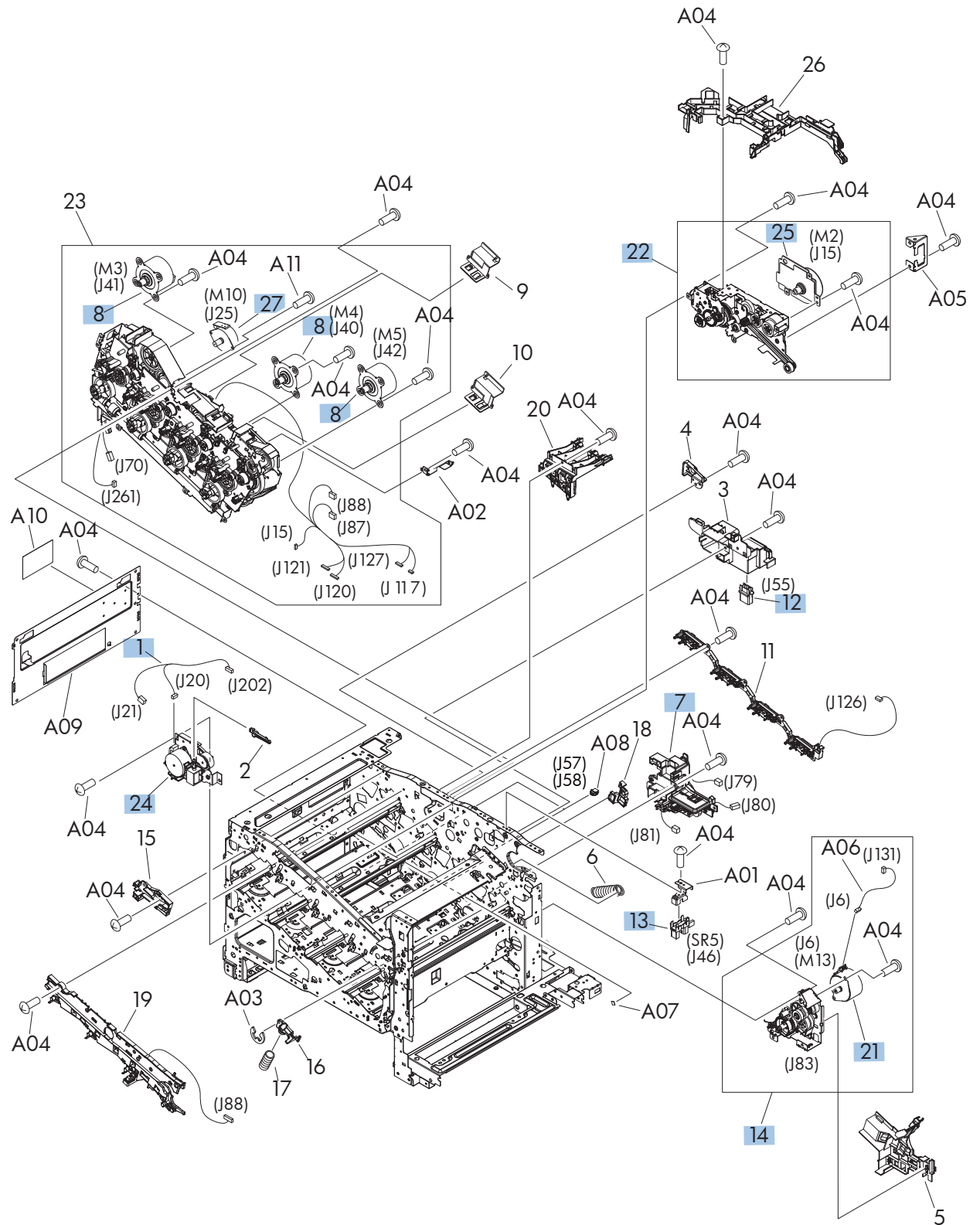

Table 2-15 Internal assemblies (6 of 6)

Ref	Description	Part number	Qty
1	Duplexing unit cable assembly	RM1-5730-000CN	1
7	Lifter drive assembly	RM1-4976-000CN	1
8	Main motor unit (M3, M4, M5)	RM1-8105-000CN	3
12	Connector, drawer	VS1-7258-007CN	1
13	Photo interrupter (SR5)	WG8-5935-000CN	1
14	Paper pick up drive assembly	RM1-8135-000CN	1
21	Pickup motor assembly (M13)	RM1-5773-000CN	1
22	Fusing drive assembly	RM1-8134-000CN	1
24	Duplex drive assembly	RM1-4973-000CN	1
25	Fusing motor assembly (M2)	RM1-4983-000CN	1
27	Stepping motor, DC (M10)	RK2-2415-000CN	1

Assessories

1 x 500-sheet paper feeder

Figure 2-11 1 x 500-sheet paper feeder

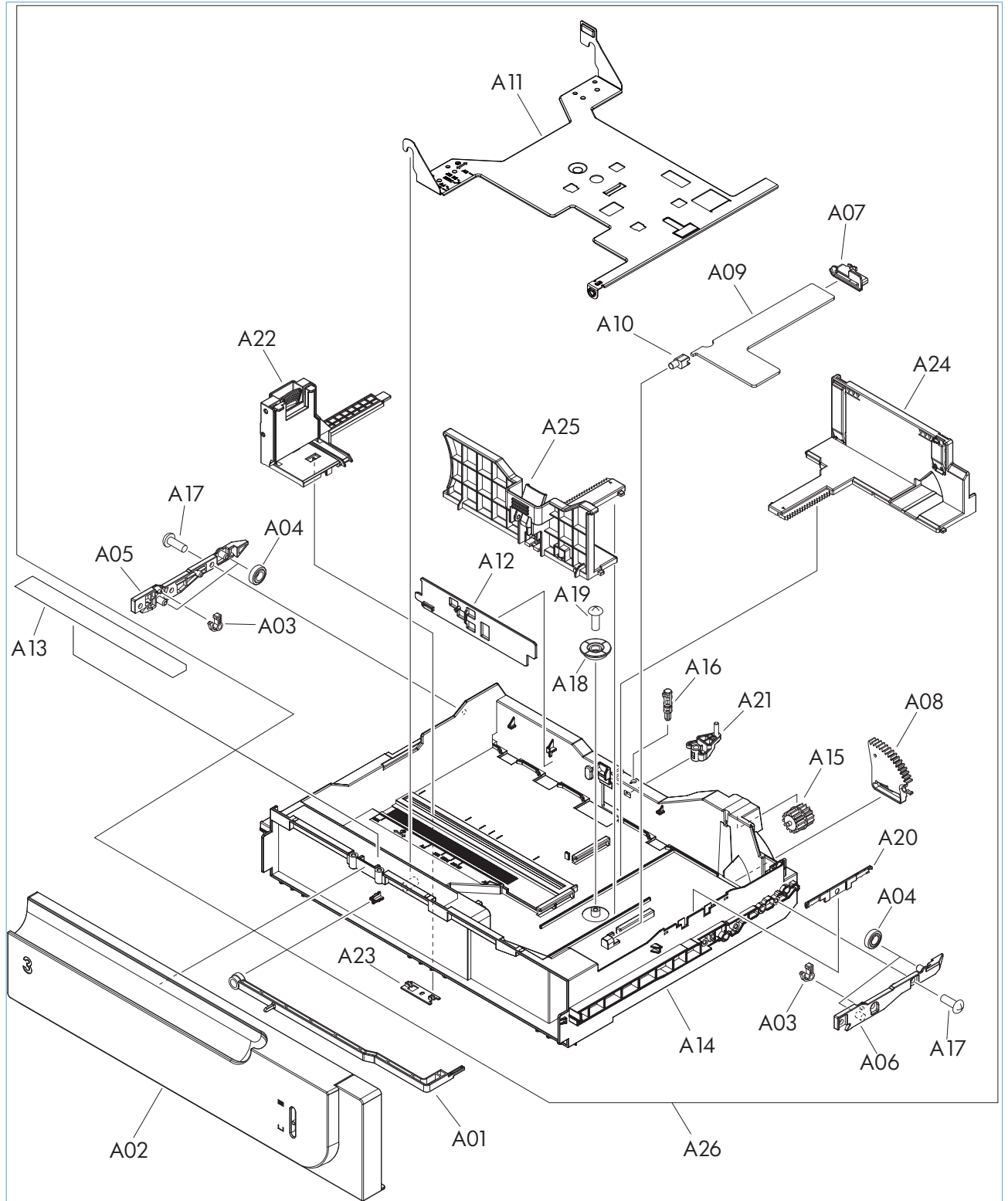

Table 2-16 1 x 500-sheet paper feeder

Ref	Description	Part number	Qty
1	1 x 500-sheet feeder replacement kit	CF084-67901	1

Paper feeder covers

Figure 2-12 Paper feeder covers

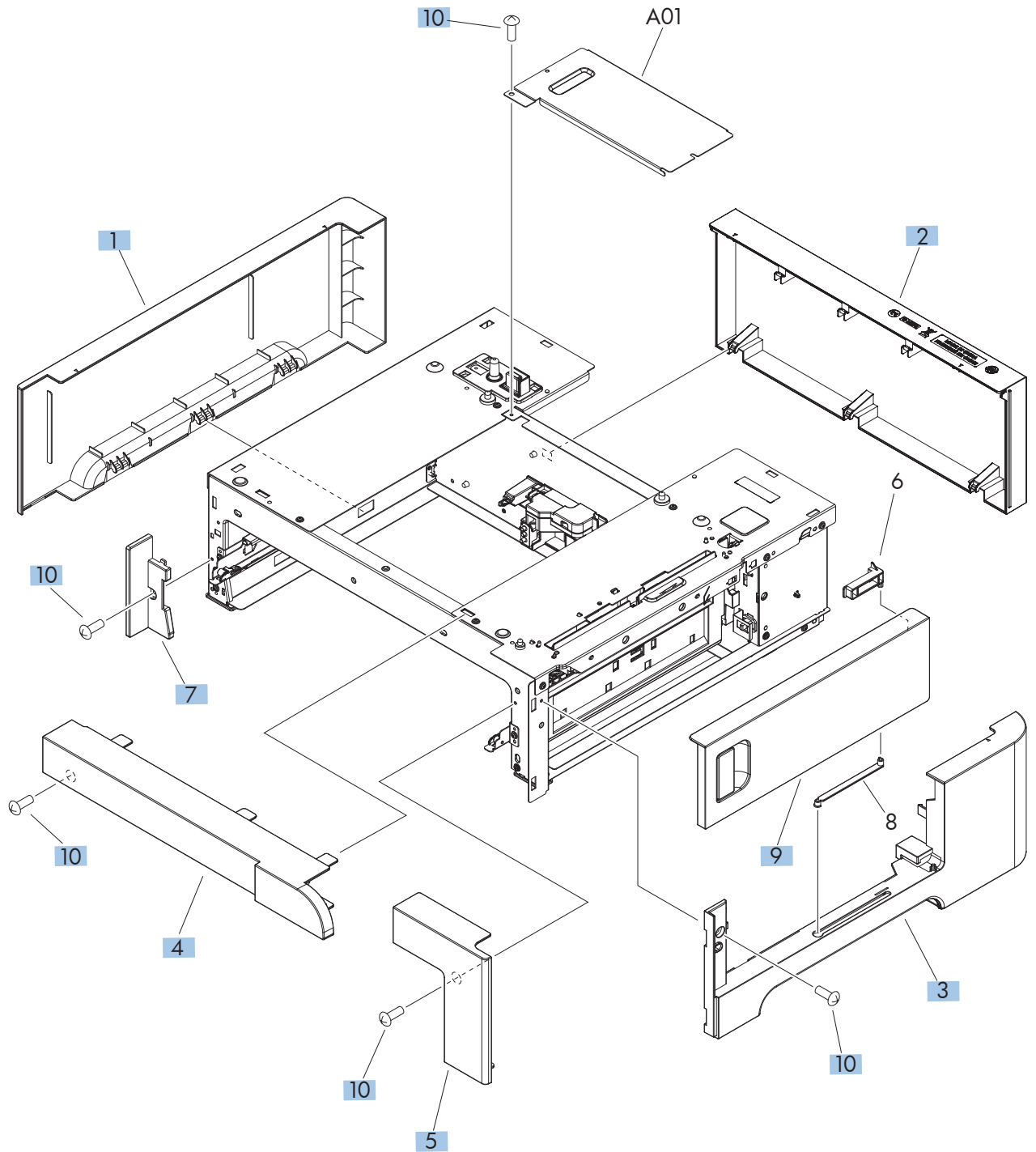

Table 2-17 Paper feeder covers

Ref	Description	Part number	Qty
1	Cover, left	RC2-5428-000CN	1
2	Cover, rear	RC2-5429-000CN	1
3	Cover, right	RC2-5427-000CN	1
4	Cover, front upper	RC2-5425-000CN	1
5	Cover, front right	RC2-5426-000CN	1
7	Cover, left front	RC2-5430-000CN	1

Paper feeder main body

Figure 2-13 Paper feeder main body

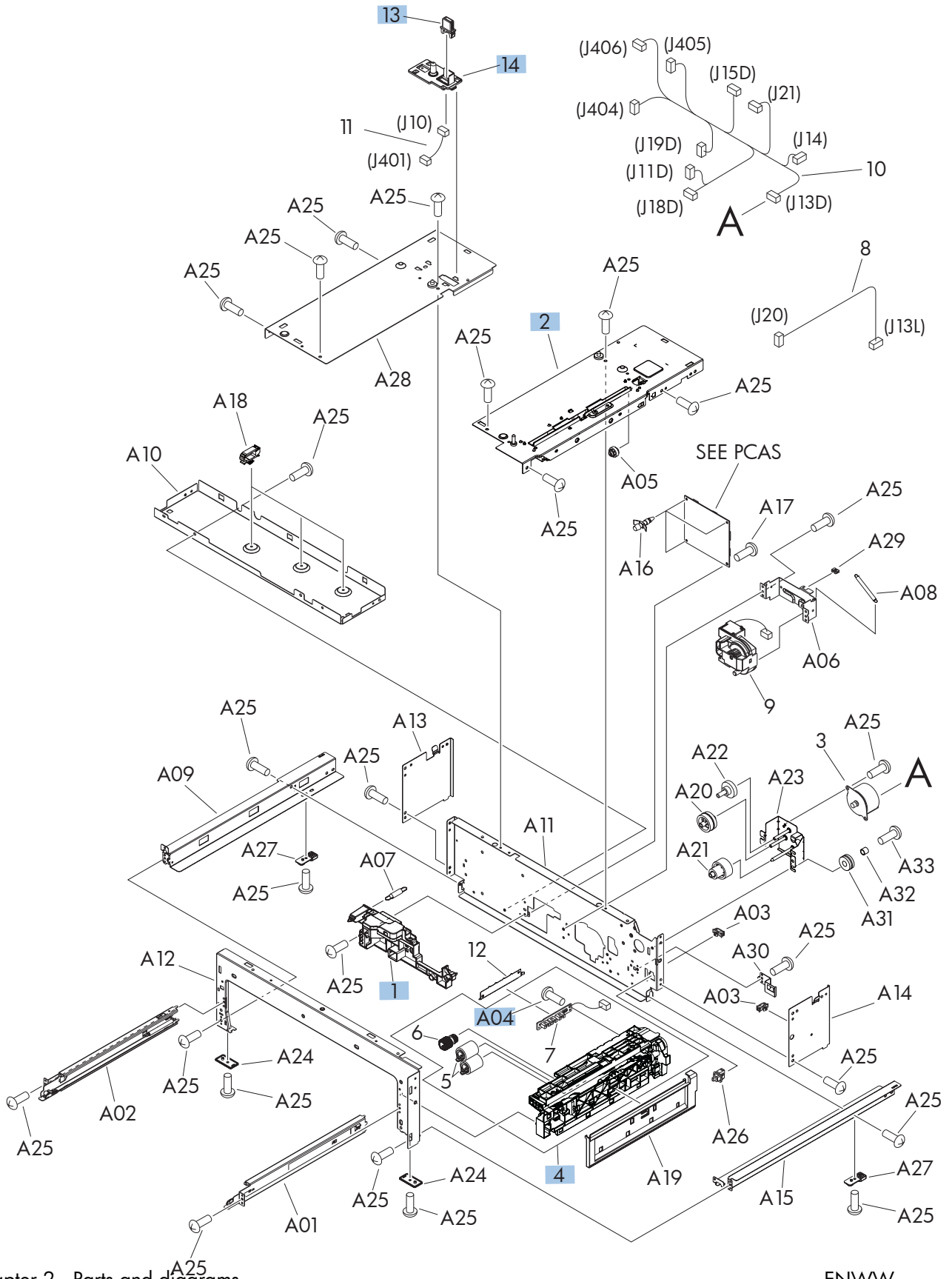

Table 2-18 Paper feeder main body

Ref	Description	Part number	Qty
1	Lifter base assembly	RM1-5913-000CN	1
2	Paper feed assembly	RM1-6194-030CN	1
4	Paper pickup assembly	RM1-5919-000CN	1
13	Drawer connector	VS1-7257-007CN	1
14	Holder, drawer connector	RC2-5416-000CN	1

Paper feeder tray

Figure 2-14 Tray

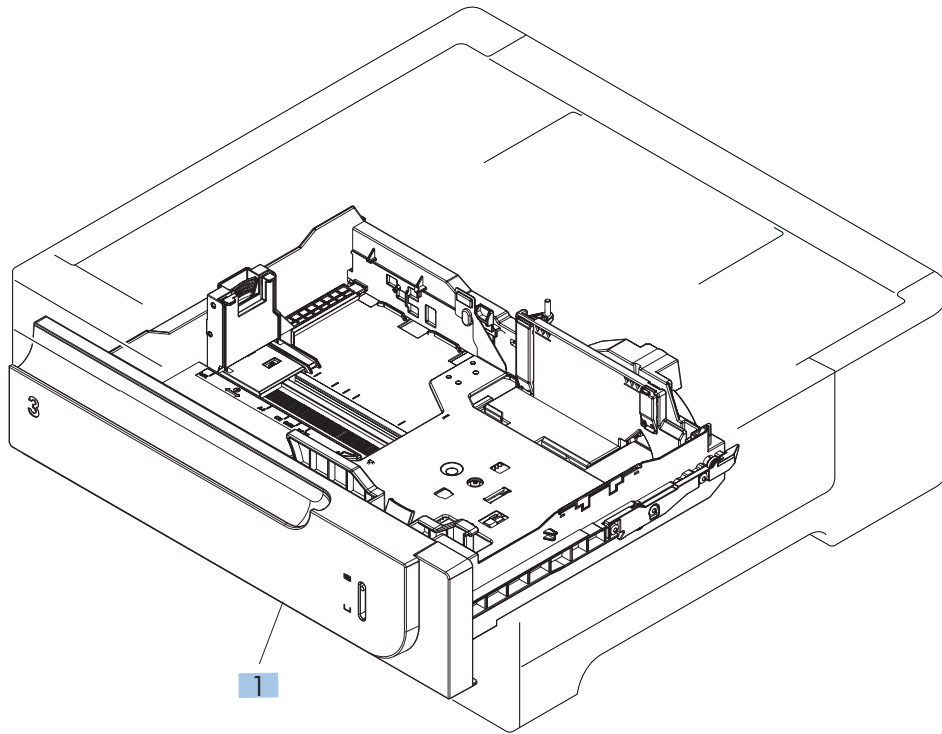

Table 2-19 Tray

Ref	Description	Part number	Qty
1	Tray 3	RM1-6198-000CN	1

Paper feeder PCA

Figure 2-15 Paper feeder PCA

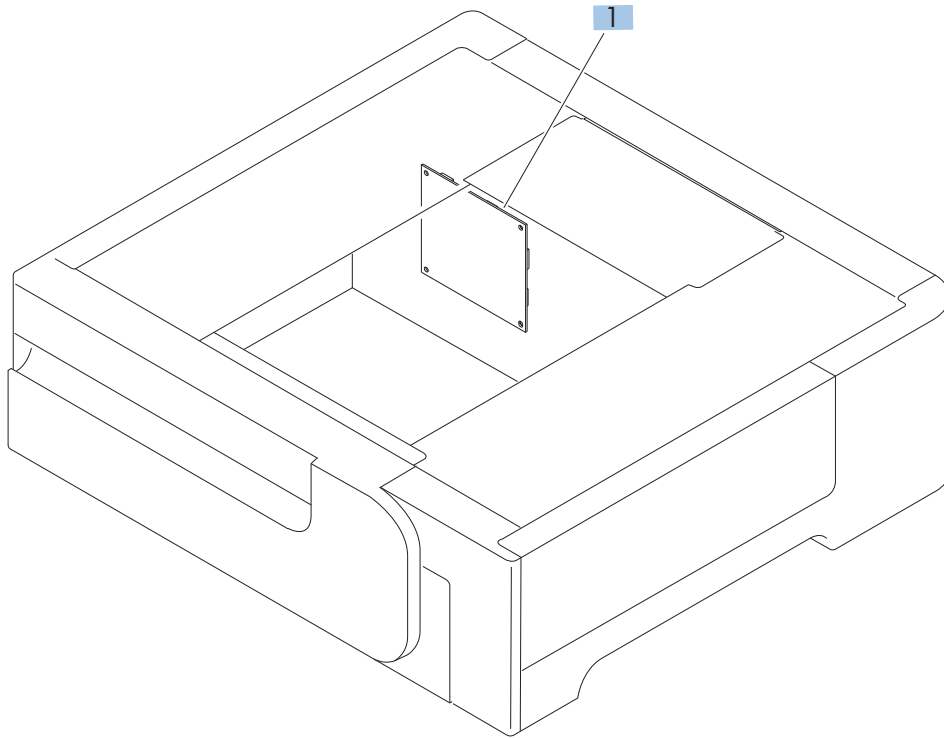

Table 2-20 Paper feeder PCA

Ref	Description	Part number	Qty
1	PCA, paper feeder driver (1 x 500)	RM1-5839-000CN	1

Alphabetical parts list

Table 2-21 Alphabetical parts list

Description	Part number	Table and page
1 x 500-sheet feeder replacement kit	CF084-67901	1 x 500-sheet paper feeder on page 223
Arm, interlock link switch	RC2-5121-000CN	Internal assemblies (3 of 6) on page 215
Base assembly	RM1-8149-000CN	Internal assemblies (2 of 6) on page 213
Button, power supply	RL1-1947-000CN	Internal assemblies (3 of 6) on page 215
Cable, laser FCC 1	RK2-3941-000CN	Internal assemblies (5 of 6) on page 219
Cable, laser FCC 2	RK2-3943-000CN	Internal assemblies (5 of 6) on page 219
Cable, MP sensor assembly	RM1-5737-000CN	Internal assemblies (5 of 6) on page 219
Cable, rear assembly	RM1-8084-000CN	Internal assemblies (5 of 6) on page 219
Cartridge lock lever holder	RC2-5957-000CN	Internal assemblies (2 of 6) on page 213
Cartridge lock lever holder	RC3-1075-000CN	Internal assemblies (2 of 6) on page 213
Cartridge lock lever holder	RC2-5956-000CN	Internal assemblies (2 of 6) on page 213
Connecting cable assembly	RM1-5749-000CN	Internal assemblies (2 of 6) on page 213
Connector, drawer	VS1-7258-007CN	Internal assemblies (6 of 6) on page 221
Control panel cover assembly	RM1-9198-000CN	External covers, panels, and doors on page 207
Cover, front inner lower	RL1-1915-000CN	Internal assemblies (1 of 6) on page 211
Cover, front inner lower unit	RL1-1914-020CN	Internal assemblies (1 of 6) on page 211
Cover, front inner upper	RC3-1070-000CN	Internal assemblies (1 of 6) on page 211
Cover, front right	RC2-5426-000CN	Paper feeder covers on page 225
Cover, front upper	RC2-5425-000CN	Paper feeder covers on page 225

Table 2-21 Alphabetical parts list (continued)

Description	Part number	Table and page
Cover, inner right lower	RC2-5019-000CN	Internal assemblies (3 of 6) on page 215
Cover, left	RC2-5052-000CN	External covers, panels, and doors on page 207
Cover, left	RC2-5428-000CN	Paper feeder covers on page 225
Cover, left front	RC2-5430-000CN	Paper feeder covers on page 225
Cover, left lower	RC2-5069-000CN	External covers, panels, and doors on page 207
Cover, left rear	RC3-2094-000CN	External covers, panels, and doors on page 207
Cover, rear	RC2-5048-000CN	External covers, panels, and doors on page 207
Cover, rear	RC2-5429-000CN	Paper feeder covers on page 225
Cover, rear right	RC2-5057-000CN	External covers, panels, and doors on page 207
Cover, right	RC3-2095-000CN	External covers, panels, and doors on page 207
Cover, right	RC2-5427-000CN	Paper feeder covers on page 225
Cover, right door gear rear	RC2-4924-000CN	External covers, panels, and doors on page 207
Cover, right front	RC2-5056-000CN	External covers, panels, and doors on page 207
Cover, right lower	RC2-5059-000CN	External covers, panels, and doors on page 207
Cover, right rear	RC3-2096-000CN	External covers, panels, and doors on page 207
Cover, upper rear	RC3-2092-000CN	External covers, panels, and doors on page 207
Cover, upper right	RC3-2093-000CN	External covers, panels, and doors on page 207
DC Controller	RM1-8119-000CN	Internal assemblies (5 of 6) on page 219
Density detect assembly	RM1-8163-000CN	Internal assemblies (3 of 6) on page 215
Door switch assembly (SW2)	RM1-5732-000CN	Internal assemblies (3 of 6) on page 215

Table 2-21 Alphabetical parts list (continued)

Description	Part number	Table and page
Drawer connector	VS1-7257-007CN	Paper feeder main body on page 227
Duplex drive assembly	RM1-4973-000CN	Internal assemblies (6 of 6) on page 221
Duplex paper feed assembly	RM1-4959-000CN	Right-door assembly on page 209
Duplexing unit cable assembly	RM1-5730-000CN	Internal assemblies (6 of 6) on page 221
Fan (FM1)	RK2-2416-000CN	Internal assemblies (5 of 6) on page 219
Fan (FM2, FM3)	RK2-2418-000CN	Internal assemblies (2 of 6) on page 213
Fan cable assembly	RM1-5746-000CN	Internal assemblies (2 of 6) on page 213
Front lock arm assembly	RM1-5532-000CN	Internal assemblies (3 of 6) on page 215
Fuser (110V)	RM1-8154-000CN	Internal assemblies (3 of 6) on page 215
Fuser (220V)	RM1-8156-000CN	Internal assemblies (3 of 6) on page 215
Fusing connecting cable assembly	RM1-5714-000CN	Internal assemblies (5 of 6) on page 219
Fusing drive assembly	RM1-8134-000CN	Internal assemblies (6 of 6) on page 221
Fusing motor assembly (M2)	RM1-4983-000CN	Internal assemblies (6 of 6) on page 221
Guide, option entrance	RC2-4915-000CN	Internal assemblies (3 of 6) on page 215
Holder, drawer connector	RC2-5416-000CN	Paper feeder main body on page 227
Interconnect PCA (ICB)	CZ272-60002	Internal assemblies (5 of 6) on page 219
Lifter base assembly	RM1-5913-000CN	Paper feeder main body on page 227
Lifter drive assembly	RM1-4976-000CN	Internal assemblies (6 of 6) on page 221
Link, door stopper	RC2-4916-000CN	Internal assemblies (3 of 6) on page 215
Link, door stopper	RC2-4916-000CN	Internal assemblies (5 of 6) on page 219

Table 2-21 Alphabetical parts list (continued)

Description	Part number	Table and page
Link, interlock	RC2-5119-000CN	Internal assemblies (3 of 6) on page 215
Link, interlock	RC2-5118-000CN	Internal assemblies (3 of 6) on page 215
Link, interlock (SW1)	RC2-5120-000CN	Internal assemblies (3 of 6) on page 215
Lower HVPS (D)	RM1-8087-000CN	Internal assemblies (5 of 6) on page 219
LVPS (110V)	RM1-8102-000CN	Internal assemblies (5 of 6) on page 219
LVPS (220V)	RM1-8103-000CN	Internal assemblies (5 of 6) on page 219
Main motor unit (M3, M4, M5)	RM1-8105-000CN	Internal assemblies (6 of 6) on page 221
Microswitch (SW3)	WC4-5171-000CN	Internal assemblies (3 of 6) on page 215
Motor/sensor cable assembly	RM1-5752-000CN	Internal assemblies (2 of 6) on page 213
Mount, interlock switch	RC2-5123-000CN	Internal assemblies (3 of 6) on page 215
Paper delivery assembly	RM1-4970-060CN	Internal assemblies (3 of 6) on page 215
Paper feed assembly	RM1-6194-030CN	Paper feeder main body on page 227
Paper pick up assembly	RM1-4967-000CN	Internal assemblies (3 of 6) on page 215
Paper pick up drive assembly	RM1-8135-000CN	Internal assemblies (6 of 6) on page 221
Paper pickup assembly	RM1-5919-000CN	Paper feeder main body on page 227
PCA, paper feeder driver (1 x 500)	RM1-5839-000CN	Paper feeder PCA on page 231
Photo interrupter (SR5)	WG8-5935-000CN	Internal assemblies (6 of 6) on page 221
Pick up lower guide assembly	RM1-9192-000CN	Internal assemblies (3 of 6) on page 215
Pickup motor assembly (M13)	RM1-5773-000CN	Internal assemblies (6 of 6) on page 221
Plate, blanking	RC2-5938-000CN	External covers, panels, and doors on page 207

Table 2-21 Alphabetical parts list (continued)

Description	Part number	Table and page
Rear handle	RC2-5042-000CN	Internal assemblies (5 of 6) on page 219
Rear lock arm assembly	RM1-5533-000CN	Internal assemblies (3 of 6) on page 215
Registration assembly	RM1-4969-000CN	Internal assemblies (3 of 6) on page 215
Right door assembly	RM1-8123-000CN	Right-door assembly on page 209
Secondary transfer assembly	RM1-4952-030CN	Internal assemblies (3 of 6) on page 215
Sensor cable assembly	RM1-5740-000CN	Internal assemblies (2 of 6) on page 213
Sensor cable assembly	RM1-5741-000CN	Internal assemblies (2 of 6) on page 213
Sensor cable guide assembly (SR7)	RM1-8178-000CN	Internal assemblies (3 of 6) on page 215
Spring, grounding	RC2-5148-000CN	Internal assemblies (5 of 6) on page 219
Stand assembly	RM1-5588-000CN	Internal assemblies (2 of 6) on page 213
Stepping motor, DC (M10)	RK2-2415-000CN	Internal assemblies (6 of 6) on page 221
Switch arm	RC2-5943-000CN	Internal assemblies (5 of 6) on page 219
Switch cable assembly	RM1-8065-000CN	Internal assemblies (3 of 6) on page 215
Switch PCA assembly	RM1-8097-000CN	Internal assemblies (3 of 6) on page 215
Temperature sensor unit	RK2-3267-000CN	Internal assemblies (2 of 6) on page 213
Toner collection unit (TCU)	RM1-4989-000CN	Internal assemblies (1 of 6) on page 211
Toner sensor holder assembly	RM1-5700-000CN	Internal assemblies (2 of 6) on page 213
Tray 2	RM1-4962-060CN	Internal assemblies (2 of 6) on page 213
Tray 3	RM1-6198-000CN	Tray on page 229
Tray, paper delivery	RL1-1941-030CN	External covers, panels, and doors on page 207

Table 2-21 Alphabetical parts list (continued)

Description	Part number	Table and page
Upper HVPS (T)	RM1-8088-000CN	Internal assemblies (5 of 6) on page 219
Waste toner box seal	RC2-4780-000CN	Internal assemblies (1 of 6) on page 211
Waste toner detect assembly	RM1-5696-000CN	Internal assemblies (1 of 6) on page 211
Waste toner duct assembly	RM1-8138-000CN	Internal assemblies (1 of 6) on page 211
Wire (mech) sensor project	RC2-4828-000CN	Internal assemblies (3 of 6) on page 215

Numerical parts list

Table 2-22 Numerical parts list

Part number	Description	Table and page
CF084-67901	1 x 500-sheet feeder replacement kit	1 x 500-sheet paper feeder on page 223
RC2-4780-000CN	Waste toner box seal	Internal assemblies (1 of 6) on page 211
RC2-4828-000CN	Wire (mech) sensor project	Internal assemblies (3 of 6) on page 215
RC2-4915-000CN	Guide, option entrance	Internal assemblies (3 of 6) on page 215
RC2-4916-000CN	Link, door stopper	Internal assemblies (3 of 6) on page 215
RC2-4916-000CN	Link, door stopper	Internal assemblies (5 of 6) on page 219
RC2-4924-000CN	Cover, right door gear rear	External covers, panels, and doors on page 207
RC2-5019-000CN	Cover, inner right lower	Internal assemblies (3 of 6) on page 215
RC2-5042-000CN	Rear handle	Internal assemblies (5 of 6) on page 219
RC2-5048-000CN	Cover, rear	External covers, panels, and doors on page 207
RC2-5052-000CN	Cover, left	External covers, panels, and doors on page 207
RC2-5056-000CN	Cover, right front	External covers, panels, and doors on page 207
RC2-5057-000CN	Cover, rear right	External covers, panels, and doors on page 207
RC2-5059-000CN	Cover, right lower	External covers, panels, and doors on page 207
RC2-5069-000CN	Cover, left lower	External covers, panels, and doors on page 207
RC2-5118-000CN	Link, interlock	Internal assemblies (3 of 6) on page 215
RC2-5119-000CN	Link, interlock	Internal assemblies (3 of 6) on page 215
RC2-5120-000CN	Link, interlock (SW1)	Internal assemblies (3 of 6) on page 215
RC2-5121-000CN	Arm, interlock link switch	Internal assemblies (3 of 6) on page 215

Table 2-22 Numerical parts list (continued)

Part number	Description	Table and page
RC2-5123-000CN	Mount, interlock switch	Internal assemblies (3 of 6) on page 215
RC2-5148-000CN	Spring, grounding	Internal assemblies (5 of 6) on page 219
RC2-5416-000CN	Holder, drawer connector	Paper feeder main body on page 227
RC2-5425-000CN	Cover, front upper	Paper feeder covers on page 225
RC2-5426-000CN	Cover, front right	Paper feeder covers on page 225
RC2-5427-000CN	Cover, right	Paper feeder covers on page 225
RC2-5428-000CN	Cover, left	Paper feeder covers on page 225
RC2-5429-000CN	Cover, rear	Paper feeder covers on page 225
RC2-5430-000CN	Cover, left front	Paper feeder covers on page 225
RC2-5938-000CN	Plate, blanking	External covers, panels, and doors on page 207
RC2-5943-000CN	Switch arm	Internal assemblies (5 of 6) on page 219
RC2-5956-000CN	Cartridge lock lever holder	Internal assemblies (2 of 6) on page 213
RC2-5957-000CN	Cartridge lock lever holder	Internal assemblies (2 of 6) on page 213
RC3-1070-000CN	Cover, front inner upper	Internal assemblies (1 of 6) on page 211
RC3-1075-000CN	Cartridge lock lever holder	Internal assemblies (2 of 6) on page 213
RC3-2092-000CN	Cover, upper rear	External covers, panels, and doors on page 207
RC3-2093-000CN	Cover, upper right	External covers, panels, and doors on page 207
RC3-2094-000CN	Cover, left rear	External covers, panels, and doors on page 207
RC3-2095-000CN	Cover, right	External covers, panels, and doors on page 207
RC3-2096-000CN	Cover, right rear	External covers, panels, and doors on page 207

Table 2-22 Numerical parts list (continued)

Part number	Description	Table and page
RK2-2415-000CN	Stepping motor, DC (M10)	Internal assemblies (6 of 6) on page 221
RK2-2416-000CN	Fan (FM1)	Internal assemblies (5 of 6) on page 219
RK2-2418-000CN	Fan (FM2, FM3)	Internal assemblies (2 of 6) on page 213
RK2-3267-000CN	Temperature sensor unit	Internal assemblies (2 of 6) on page 213
RK2-3941-000CN	Cable, laser FCC 1	Internal assemblies (5 of 6) on page 219
RK2-3943-000CN	Cable, laser FCC 2	Internal assemblies (5 of 6) on page 219
RL1-1914-020CN	Cover, front inner lower unit	Internal assemblies (1 of 6) on page 211
RL1-1915-000CN	Cover, front inner lower	Internal assemblies (1 of 6) on page 211
RL1-1941-030CN	Tray, paper delivery	External covers, panels, and doors on page 207
RL1-1947-000CN	Button, power supply	Internal assemblies (3 of 6) on page 215
RM1-4952-030CN	Secondary transfer assembly	Internal assemblies (3 of 6) on page 215
RM1-4959-000CN	Duplex paper feed assembly	Right-door assembly on page 209
RM1-4962-060CN	Tray 2	Internal assemblies (2 of 6) on page 213
RM1-4967-000CN	Paper pick up assembly	Internal assemblies (3 of 6) on page 215
RM1-4969-000CN	Registration assembly	Internal assemblies (3 of 6) on page 215
RM1-4970-060CN	Paper delivery assembly	Internal assemblies (3 of 6) on page 215
RM1-4973-000CN	Duplex drive assembly	Internal assemblies (6 of 6) on page 221
RM1-4976-000CN	Lifter drive assembly	Internal assemblies (6 of 6) on page 221
RM1-4983-000CN	Fusing motor assembly (M2)	Internal assemblies (6 of 6) on page 221
RM1-4989-000CN	Toner collection unit (TCU)	Internal assemblies (1 of 6) on page 211

Table 2-22 Numerical parts list (continued)

Part number	Description	Table and page
RM1-5532-000CN	Front lock arm assembly	Internal assemblies (3 of 6) on page 215
RM1-5533-000CN	Rear lock arm assembly	Internal assemblies (3 of 6) on page 215
RM1-5588-000CN	Stand assembly	Internal assemblies (2 of 6) on page 213
RM1-5696-000CN	Waste toner detect assembly	Internal assemblies (1 of 6) on page 211
RM1-5700-000CN	Toner sensor holder assembly	Internal assemblies (2 of 6) on page 213
RM1-5714-000CN	Fusing connecting cable assembly	Internal assemblies (5 of 6) on page 219
RM1-5730-000CN	Duplexing unit cable assembly	Internal assemblies (6 of 6) on page 221
RM1-5732-000CN	Door switch assembly (SW2)	Internal assemblies (3 of 6) on page 215
RM1-5737-000CN	Cable, MP sensor assembly	Internal assemblies (5 of 6) on page 219
RM1-5740-000CN	Sensor cable assembly	Internal assemblies (2 of 6) on page 213
RM1-5741-000CN	Sensor cable assembly	Internal assemblies (2 of 6) on page 213
RM1-5746-000CN	Fan cable assembly	Internal assemblies (2 of 6) on page 213
RM1-5749-000CN	Connecting cable assembly	Internal assemblies (2 of 6) on page 213
RM1-5752-000CN	Motor/sensor cable assembly	Internal assemblies (2 of 6) on page 213
RM1-5773-000CN	Pickup motor assembly (M13)	Internal assemblies (6 of 6) on page 221
RM1-5839-000CN	PCA, paper feeder driver (1 x 500)	Paper feeder PCA on page 231
RM1-5913-000CN	Lifter base assembly	Paper feeder main body on page 227
RM1-5919-000CN	Paper pickup assembly	Paper feeder main body on page 227
RM1-6194-030CN	Paper feed assembly	Paper feeder main body on page 227
RM1-6198-000CN	Tray 3	Tray on page 229

Table 2-22 Numerical parts list (continued)

Part number	Description	Table and page
RM1-8065-000CN	Switch cable assembly	Internal assemblies (3 of 6) on page 215
RM1-8084-000CN	Cable, rear assembly	Internal assemblies (5 of 6) on page 219
CZ272-60002	Interconnect PCA (ICB)	Internal assemblies (5 of 6) on page 219
RM1-8087-000CN	Lower HVPS (D)	Internal assemblies (5 of 6) on page 219
RM1-8088-000CN	Upper HVPS (T)	Internal assemblies (5 of 6) on page 219
RM1-8097-000CN	Switch PCA assembly	Internal assemblies (3 of 6) on page 215
RM1-8102-000CN	LVPS (110V)	Internal assemblies (5 of 6) on page 219
RM1-8103-000CN	LVPS (220V)	Internal assemblies (5 of 6) on page 219
RM1-8105-000CN	Main motor unit (M3, M4, M5)	Internal assemblies (6 of 6) on page 221
RM1-8119-000CN	DC Controller	Internal assemblies (5 of 6) on page 219
RM1-8123-000CN	Right door assembly	Right-door assembly on page 209
RM1-8134-000CN	Fusing drive assembly	Internal assemblies (6 of 6) on page 221
RM1-8135-000CN	Paper pick up drive assembly	Internal assemblies (6 of 6) on page 221
RM1-8138-000CN	Waste toner duct assembly	Internal assemblies (1 of 6) on page 211
RM1-8149-000CN	Base assembly	Internal assemblies (2 of 6) on page 213
RM1-8154-000CN	Fuser (110V)	Internal assemblies (3 of 6) on page 215
RM1-8156-000CN	Fuser (220V)	Internal assemblies (3 of 6) on page 215
RM1-8163-000CN	Density detect assembly	Internal assemblies (3 of 6) on page 215
RM1-8178-000CN	Sensor cable guide assembly (SR7)	Internal assemblies (3 of 6) on page 215
RM1-9192-000CN	Pick up lower guide assembly	Internal assemblies (3 of 6) on page 215

Table 2-22 Numerical parts list (continued)

Part number	Description	Table and page
RM1-9198-000CN	Control panel cover assembly	External covers, panels, and doors on page 207
VS1-7257-007CN	Drawer connector	Paper feeder main body on page 227
VS1-7258-007CN	Connector, drawer	Internal assemblies (6 of 6) on page 221
WC4-5171-000CN	Microswitch (SW3)	Internal assemblies (3 of 6) on page 215
WG8-5935-000CN	Photo interrupter (SR5)	Internal assemblies (6 of 6) on page 221

Index

A

- accessories
 - ordering 194
 - part numbers 195
- after service checklist 5

C

- cartridges
 - removing 9
- cartridges, print
 - part numbers 196
- cassette
 - tray 2, removing 14
 - tray 3, removing 14
- cautions iii
- checklists
 - after service 5
 - preservice 5
- components
 - Registration density (RD) sensor assembly, removing 117
 - residual-toner-feed motor, removing 107
 - toner-collection sensor, removing 104
- control panel
 - removing 32
- conventions, document iii
- covers
 - delivery cover, removing 62
 - front-door assembly, removing 27
 - front-top, removing 69
 - front-upper cover, removing 42
 - left, removing 50
 - left-upper cover, removing 54
 - rear cover, removing 56
 - rear-toptop, removing 71

- rear-upper cover, removing 53
- right-door assembly, removing 44
- right-front, removing 58
- right-rear, removing 48
- right-top cover, removing 64

D

- DC controller PCA and tray, removing 91
- delivery assembly
 - removing 184
- delivery cover, removing 62
- diagrams 193
- document conventions iii
- document feeder
 - removing 73
- drawer connector
 - drawer connector, removing 191
- duplexing unit
 - duplex-drive assembly, removing 189

E

- electrostatic discharge (ESD) 3
- ESD (electrostatic discharge) 3

F

- fans
 - cartridge, removing 99
 - delivery, removing 99
 - power-supply fan and fan duct, removing 121
- fasteners
 - screws 202
- fax PCA, removing 85
- formatter
 - PCA, removing 83

- front-door assembly, removing 27
- front-top cover, removing 69
- front-upper cover, removing 42
- fuser
 - drive assembly, removing 179
 - motor, removing 167

H

- high-voltage power supply
 - removing, lower 129
 - removing, upper 161

I

- ICB, removing 88
- image scanner
 - removing 77
- intermediate transfer belt (ITB) 24

L

- laser/scanner
 - assembly (C/Bk), removing 153
 - assembly (Y/M), removing 146
- left cover, removing 50
- left-upper cover, removing 54
- lifter-drive assembly
 - removing 135
- location
 - optional trays or accessories (base product) 205
- LVPS, removing 94

M

- main-drive assembly
 - removing 168
- motors
 - developing-disengagement, removing 132

- drum motor 1, removing 165
 - drum motor 2 or 3, removing 166
 - fuser, removing 167
 - pickup, removing 134
- N**
- notes iii
- O**
- ordering
 - part numbers for 195
 - product documents 202
 - supplies and accessories 194
- P**
- part numbers
 - print cartridges 196
 - screws 202
 - toner collection unit 196
 - parts 193
 - optional trays or accessories (base product) 205
 - parts lists and diagrams
 - covers 206
 - internal assemblies 210, 212, 214, 216, 218, 220
 - using 203
 - pliers, required 3
 - post-service tests 6
 - preservice checklist 5
 - print cartridges
 - part numbers 196
 - print-quality test 6
- R**
- rear cover, removing 56
 - rear-top cover, removing 71
 - rear-upper cover, removing 53
 - registration assembly
 - removing 124
 - Registration density (RD) sensor assembly, removing 117
 - removing parts
 - cartridge fan 99
 - cautions for 2
 - checklists 5
 - DC controller PCA and tray 91
 - delivery assembly 184
 - delivery cover 62
 - delivery fan 99
 - developing-disengagement motor 132
 - document feeder 73
 - drawer connector 191
 - drum motor 1 165
 - drum motor 2 or 3 166
 - duplex-drive assembly 189
 - environmental sensor 99
 - fax PCA 85
 - formatter PCA 83
 - front-door assembly 27
 - front-top cover 69
 - front-upper cover 42
 - fuser 81
 - fuser motor 167
 - fuser-drive assembly 179
 - high-voltage power supply lower 129
 - high-voltage power supply upper 161
 - ICB 88
 - image scanner 77
 - intermediate transfer belt 24
 - laser/scanner assembly (C/Bk) 153
 - laser/scanner assembly (Y/M) 146
 - left cover 50
 - left-upper cover 54
 - lifter-drive assembly 135
 - LVPS 94
 - main-drive assembly 168
 - pickup motor 134
 - pickup roller (tray 1) 15
 - pickup roller (tray 2) 17
 - power-supply fan and fan duct 121
 - rear cover 56
 - rear-top cover 71
 - rear-upper cover 53
 - registration assembly 124
 - Registration density (RD) sensor assembly 117
 - residual-toner-feed motor 107
 - right-door assembly 44
 - right-front cover 58
 - right-rear cover 48
 - right-top cover 64
 - secondary transfer assembly 112
 - secondary transfer roller 22
 - separation roller (tray 2) 21
 - service approach 5
 - toner cartridges 9
 - toner-collection sensor 104
 - toner-collection unit 12
 - tools, required 3
 - tray 14
 - tray-pickup assembly 144
 - tray-pickup drive assembly 137
 - repair approach 5
 - replacing
 - parts 2
 - replacing parts
 - service approach 5
 - residual-toner-feed motor, removing 107
 - right-front cover, removing 58
 - right-top cover, removing 64
 - roller
 - pickup roller (Tray 1), removing 15
 - pickup roller (Tray 2), removing 17
 - rollers
 - secondary transfer roller, removing 112
 - separation roller (Tray 2), removing 21
- S**
- screwdrivers, required 3
 - screws
 - part numbers 202
 - replacing 2
 - types of 4
 - secondary transfer roller, removing 22
 - sensors
 - environmental, removing 99
 - service
 - approach 5
 - tools, required 3
 - static precautions 3
 - supplies
 - ordering 194
 - part numbers 195, 196

T

TCU

part numbers 196

tests

post-service 6

print-quality 6

tips iii

toner cartridges

removing 9

toner collection unit

part numbers 196

removing 12

toner-collection sensor, removing

104

tools, required 3

tray

pickup assembly, removing

144

pickup drive assembly,

removing 137

trays

removing 14

troubleshooting

service approach 5

W

warnings iii

Web sites

ordering supplies 194



CZ271-91020

