



LASERJET ENTERPRISE 500 COLOR MFP LASERJET ENTERPRISE FLOW MFP M575

Repair Manual



M575



M575c



HP LaserJet Enterprise 500 color MFP
M575 Printers

HP LaserJet Enterprise 500 color flow
MFP M575 Printers

Repair Manual

Copyright and License

© 2012 Copyright Hewlett-Packard Development Company, L.P.

Reproduction, adaptation, or translation without prior written permission is prohibited, except as allowed under the copyright laws.

The information contained herein is subject to change without notice.

The only warranties for HP products and services are set forth in the express warranty statements accompanying such products and services. Nothing herein should be construed as constituting an additional warranty. HP shall not be liable for technical or editorial errors or omissions contained herein.

Part number: CD644-90966

Edition 2, 11/2012

Trademark Credits

Adobe®, Adobe Photoshop®, Acrobat®, and PostScript® are trademarks of Adobe Systems Incorporated.

Apple and the Apple logo are trademarks of Apple Computer, Inc., registered in the U.S. and other countries. iPod is a trademark of Apple Computer, Inc. iPod is for legal or rightholder-authorized copying only. Don't steal music.

Microsoft®, Windows®, Windows® XP, and Windows Vista® are U.S. registered trademarks of Microsoft Corporation.

PANTONE® is Pantone, Inc's check-standard trademark for color.

UNIX® is a registered trademark of The Open Group.

ENERGY STAR and the ENERGY STAR mark are registered U.S. marks.

Conventions used in this guide

 **TIP:** Tips provide helpful hints or shortcuts.

 **NOTE:** Notes provide important information to explain a concept or to complete a task.

 **CAUTION:** Cautions indicate procedures that you should follow to avoid losing data or damaging the product.

 **WARNING!** Warnings alert you to specific procedures that you should follow to avoid personal injury, catastrophic loss of data, or extensive damage to the product.

Table of contents

1 Removal and replacement	1
Introduction	2
Removal and replacement strategy	2
General cautions during removal and replacement	2
Electrostatic discharge	3
Required tools	3
Types of screws	4
Service approach	5
Before performing service	6
After performing service	6
Post-service test	7
Print-quality test	7
Copy-quality test	7
DC controller PCA	8
Parts removal order	9
Removal and replacement procedures	11
Customer self repair (CSR) components	11
Toner cartridges	11
Staple cartridge	13
Duplex-reverse guide	14
Toner-collection unit	15
Formatter PCA	17
Fax PCA and cable	18
Remove the fax PCA and cable	18
Hard drive	20
Remove the HDD	20
Install a replacement hard drive	22
Tray 2 and 3	23
Fuser	24
Pickup roller and separation pad (Tray 1)	25
Pickup roller (Tray 2)	27
Pickup and feed rollers (Tray 3)	29

Separation roller (Tray 2)	31
Secondary transfer roller	32
Reinstall the transfer roller	33
Intermediate transfer belt (ITB)	34
Front-door assembly	37
Foam reflector kit	38
Document feeder pickup roller	39
Document feeder separation pad and spring	41
Control panel	44
Control-panel assembly (M575c model)	47
Important removal considerations	47
Remove the control-panel assembly	49
Reinstall the control-panel assembly	56
Control-panel assembly to keyboard FFC (M575c model)	63
Important considerations	63
Remove the control-panel assembly to keyboard FFC	64
Reinstall the control-panel assembly to keyboard FFC	65
Keyboard assembly (M575c model)	68
Remove the keyboard assembly	68
Keyboard overlay (M575c model)	72
Install a keyboard overlay	72
Back-side background selector assembly (M575c model)	76
Right door (optional paper feeder)	78
External panels, covers, and doors	80
Identification and location	80
Control-panel USB cover	81
Control-panel HIP (hardward integration pocket)	82
Front-upper cover	83
Remove the front-upper cover	83
Stapler cover	85
Remove the stapler cover	85
Right-door assembly	86
Right-rear cover	90
Left cover	92
Rear-upper cover	95
Left-upper cover	97
Remove the left-upper cover	97
Rear cover	98
Remove the rear cover	98
Right-front cover	100
Remove the right-front cover	100

Delivery cover	104
Remove the delivery cover	104
Right-top cover	106
Remove the right-top cover	106
Upper-right cover	108
Remove the upper-right cover	108
Front-top cover	110
Remove the front-top cover	110
Rear-top cover	112
Remove the rear-top cover	112
Document feeder and scanner assemblies	114
Cover front (document feeder front cover)	114
Cover rear (document feeder rear cover)	116
Deskew mylar and separation mylar	118
Document feeder tray extender	120
Document feeder jam-access cover	121
Document feeder roller cover	124
Document feeder whole unit	127
Reinstall the document feeder	129
Document feeder whole unit (M575c model)	130
Remove the document feeder	130
Reinstall the document feeder	131
Document feeder hinge assy	132
Scanner-control board (SCB)	133
Remove the SCB	133
Scanner-control board (SCB; M575c)	136
Remove the SCB	136
Image scanner whole unit	139
Remove the scanner assembly	139
Reinstall the scanner	142
Internal assemblies	147
Stapler assembly	147
Remove the stapler assembly	147
Interconnect board (ICB)	148
Remove the ICB	148
DC controller PCA and tray	150
Remove the DC controller PCA and tray	150
Low-voltage power supply (LVPS)	153
Remove the LVPS	153
Delivery fan, cartridge fan, and environmental sensor	158
Remove the delivery fan, cartridge fan, and environmental sensor ..	158

Toner-collection sensor	163
Remove the toner-collection sensor	163
Residual-toner-feed motor	166
Remove the residual-toner-feed motor	166
Secondary transfer assembly	171
Reinstall the secondary transfer assembly	172
Lower pickup guide	173
Remove the lower pickup guide	173
Reinstall the lower pickup guide	176
Registration density (RD) sensor assembly	177
Remove the RD sensor assembly	177
Power-supply fan and fan duct	181
Remove the power-supply fan and fan duct	181
Registration assembly	184
Remove the registration assembly	184
High-voltage power supply lower	189
Remove the high-voltage power supply lower	189
Developing-disengagement motor	192
Remove the developing-disengagement motor	192
Pickup motor	194
Remove the pickup motor	194
Lifter-drive assembly	195
Remove the lifter-drive assembly	195
Tray-pickup drive assembly	197
Remove the tray-pickup drive assembly	197
Tray-pickup assembly	204
Remove the tray-pickup assembly	204
Laser/scanner assembly (Y/M)	206
Remove the laser/scanner assembly (Y/M)	206
Laser/scanner assembly (C/Bk)	213
Remove the laser/scanner assembly (C/Bk)	214
High-voltage power supply upper	221
Remove the high-voltage power supply upper	221
Drum motor 1	225
Remove the drum motor 1	225
Drum motor 2 or drum motor 3	226
Remove the drum motor 2 or drum motor 3	226
Fuser motor	227
Remove the fuser motor	227
Main-drive assembly	228
Remove the main-drive assembly	229

Fuser-drive assembly	239
Remove the fuser-drive assembly	240
Delivery assembly	244
Remove the delivery assembly	245
Duplex-drive assembly	249
Remove the duplex-drive assembly	250
Optional paper feeder assembly (Tray 3)	251
Drawer connector	251

2 Parts and diagrams 253

Order parts, accessories, and supplies	254
Oderable parts	254
Accessories	254
Print cartridges and toner collection unit	255
Memory	256
Customer self repair and service kits	256
Related documentation and software	262
Fasteners used in this product	262
How to use the parts lists and diagrams	263
Assembly locations	264
Base product (no optional trays or accessories)	264
Base product (optional trays or accessories)	265
Covers	266
Document feeder and scanner assemblies (M575dn and 575f models)	268
Document feeder and scanner assemblies (M575c model)	270
Keyboard (M575c model)	272
Control panel assembly	274
ADF assemblies	276
Scanner assemblies	278
Right-door assembly	280
Internal assemblies	282
Internal assemblies (1 of 6)	282
Internal assemblies (2 of 6)	284
Internal assemblies (3 of 6)	286
Internal assemblies (4 of 6)	288
Internal assemblies (5 of 6)	290
Internal assemblies (6 of 6)	292
Tray 2	294
Paper pickup assembly	296
PCAs	298
Assessorries	300

1 x 500-sheet paper feeder	300
Paper feeder covers	302
Paper feeder main body	304
Paper feeder cassette	306
Paper feeder PCA	308
Alphabetical parts list	310
Numerical parts list	320

Index	331
--------------------	------------

List of tables

Table 1-1	DC controller connectors	8
Table 1-2	External panels, covers, doors, and scanner assembly; identification and location	80
Table 2-1	Accessories	254
Table 2-2	Related documentation and software	262
Table 2-3	Common fasteners	262
Table 2-4	Optional 500-sheet input tray	265
Table 2-5	External covers, panels, and doors	267
Table 2-6	Document feeder and scanner assemblies (M575dn and 575f models)	269
Table 2-7	Docuement feeder and scanner assemblies (575c models)	271
Table 2-8	Keyboard and brackets	273
Table 2-9	Control panel assembly	275
Table 2-10	ADF assemblies	277
Table 2-11	Scanner assemblies	279
Table 2-12	Right-door assembly	281
Table 2-13	Internal assemblies (1 of 6)	283
Table 2-14	Internal assemblies (2 of 6)	285
Table 2-15	Internal assemblies (3 of 6)	287
Table 2-16	Internal assemblies (4 of 6)	289
Table 2-17	Internal assemblies (5 of 6)	291
Table 2-18	Internal assemblies (6 of 6)	293
Table 2-19	Tray 2	295
Table 2-20	Paper pickup assembly (Tray 2)	297
Table 2-21	PCAs	299
Table 2-22	1 x 500-sheet paper feeder	301
Table 2-23	Paper feeder covers	303
Table 2-24	Paper feeder main body	305
Table 2-25	Paper feeder cassette	307
Table 2-26	Paper feeder PCA	309
Table 2-27	Alphabetical parts list	310
Table 2-28	Numerical parts list	320

List of figures

Figure 1-1	Phillips and Pozidriv screwdriver comparison	3
Figure 1-2	DC controller PCA	8
Figure 1-3	Parts removal order (1 of 3)	9
Figure 1-4	Parts removal order (2 of 3)	9
Figure 1-5	Parts removal order (3 of 3)	10
Figure 1-6	Remove the toner cartridge (1 of 2)	11
Figure 1-7	Remove the toner cartridge (2 of 2)	12
Figure 1-8	Remove the staple cartridge	13
Figure 1-9	Remove the duplex-reverse guide (1 of 2)	14
Figure 1-10	Remove the duplex-reverse guide (2 of 2)	14
Figure 1-11	Remove the toner-collection unit (1 of 4)	15
Figure 1-12	Remove the toner-collection unit (2 of 4)	15
Figure 1-13	Remove the toner-collection unit (3 of 4)	16
Figure 1-14	Remove the toner-collection unit (4 of 4)	16
Figure 1-15	Remove the formatter	17
Figure 1-16	Remove the fax PCA and cable (1 of 2)	18
Figure 1-17	Remove the fax PCA and cable (2 of 2)	19
Figure 1-18	Remove the HDD (1 of 3)	20
Figure 1-19	Remove the HDD (2 of 3)	21
Figure 1-20	Remove the HDD (3 of 3)	21
Figure 1-21	Remove Tray 2 and 3 (1 of 2)	23
Figure 1-22	Remove Tray 2 and 3 (2 of 2)	23
Figure 1-23	Remove the fuser (1 of 2)	24
Figure 1-24	Remove the fuser (2 of 2)	24
Figure 1-25	Remove the pickup roller and separation pad (Tray 1; 1 of 3)	25
Figure 1-26	Remove the pickup roller and separation pad (Tray 1; 2 of 3)	25
Figure 1-27	Remove the pickup roller and separation pad (Tray 1; 3 of 3)	26
Figure 1-28	Remove the pickup roller (Tray 2; 1 of 4)	27
Figure 1-29	Remove the pickup roller (Tray 2; 2 of 4)	27
Figure 1-30	Remove the pickup roller (Tray 2; 3 of 4)	28
Figure 1-31	Remove the pickup roller (Tray 2; 4 of 4)	28
Figure 1-32	Remove the Pickup and feed rollers (Tray 3; 1 of 2)	29

Figure 1-33	Remove the Pickup and feed rollers (Tray 3; 2 of 2)	30
Figure 1-34	Remove the separation roller (Tray 2)	31
Figure 1-35	Remove the transfer roller (1 of 3)	32
Figure 1-36	Remove the transfer roller (2 of 3)	32
Figure 1-37	Remove the transfer roller (3 of 3)	33
Figure 1-38	Reinstall the transfer roller	33
Figure 1-39	Remove the fuser (1 of 2)	34
Figure 1-40	Remove the intermediate transfer belt (1 of 3)	34
Figure 1-41	Remove the intermediate transfer belt (2 of 3)	35
Figure 1-42	Remove the intermediate transfer belt (3 of 3)	36
Figure 1-43	Remove the front-door assembly (1 of 2)	37
Figure 1-44	Remove the front-door assembly (2 of 2)	37
Figure 1-45	Remove the foam reflector kit (1 of 2)	38
Figure 1-46	Reinstall the foam reflector	38
Figure 1-47	Remove the document feeder pickup roller (1 of 4)	39
Figure 1-48	Remove the document feeder pickup roller (2 of 4)	39
Figure 1-49	Remove the document feeder pickup roller (3 of 4)	40
Figure 1-50	Remove the document feeder pickup roller (4 of 4)	40
Figure 1-51	Remove the document feeder separation pad and separation pad spring (1 of 5)	41
Figure 1-52	Remove the document feeder separation pad and separation pad spring (2 of 5)	41
Figure 1-53	Remove the document feeder separation pad and separation pad spring (3 of 5)	42
Figure 1-54	Remove the document feeder separation pad and separation pad spring (4 of 5)	42
Figure 1-55	Remove the document feeder separation pad and separation pad spring (5 of 5)	43
Figure 1-56	Reinstall the document feeder separation pad spring	43
Figure 1-57	Remove the control panel (1 of 5)	44
Figure 1-58	Remove the control panel (2 of 5)	44
Figure 1-59	Remove the control panel (3 of 5)	45
Figure 1-60	Remove the control panel (4 of 5)	45
Figure 1-61	Remove the control panel (5 of 5)	46
Figure 1-62	Raising the control panel to access the FFC connector (1 of 2)	47
Figure 1-63	Raise the control panel to access the FFC connector (2 of 2)	48
Figure 1-64	Check the control panel FFC for damage (1 of 2)	48
Figure 1-65	Check the control panel FFC for damage (2 of 2)	49
Figure 1-66	Remove the control-panel assembly (1 of 13)	49
Figure 1-67	Remove the control-panel assembly (2 of 13)	50
Figure 1-68	Remove the control-panel assembly (3 of 13)	50
Figure 1-69	Remove the control-panel assembly (4 of 13)	51
Figure 1-70	Remove the control-panel assembly (5 of 13)	51
Figure 1-71	Remove the control-panel assembly (6 of 13)	52
Figure 1-72	Remove the control-panel assembly (7 of 13)	52
Figure 1-73	Remove the control-panel assembly (8 of 13)	53

Figure 1-74	Remove the control-panel assembly (9 of 13)	54
Figure 1-75	Remove the control-panel assembly (10 of 13)	54
Figure 1-76	Remove the control-panel assembly (11 of 13)	55
Figure 1-77	Remove the control-panel assembly (12 of 13)	55
Figure 1-78	Remove the control-panel assembly (13 of 13)	56
Figure 1-79	Reinstall the control-panel assembly (1 of 13)	56
Figure 1-80	Reinstall the control-panel assembly (2 of 13)	57
Figure 1-81	Reinstall the control-panel assembly (3 of 13)	57
Figure 1-82	Reinstall the control-panel assembly (4 of 13)	58
Figure 1-83	Reinstall the control-panel assembly (5 of 13)	58
Figure 1-84	Reinstall the control-panel assembly (6 of 13)	59
Figure 1-85	Reinstall the control-panel assembly (7 of 13)	59
Figure 1-86	Reinstall the control-panel assembly (8 of 13)	60
Figure 1-87	Reinstall the control-panel assembly (9 of 13)	60
Figure 1-88	Reinstall the control-panel assembly (10 of 13)	61
Figure 1-89	Reinstall the control-panel assembly (11 of 13)	61
Figure 1-90	Reinstall the control-panel assembly (12 of 13)	62
Figure 1-91	Remove the control-panel assembly (13 of 13)	62
Figure 1-92	Control-panel assembly to keyboard FFC	63
Figure 1-93	Remove the control-panel assembly to keyboard FFC (1 of 3)	64
Figure 1-94	Remove the control-panel assembly to keyboard FFC (2 of 3)	64
Figure 1-95	Remove the control-panel assembly to keyboard FFC (3 of 3)	65
Figure 1-96	Reinstall the control-panel assembly to keyboard FFC (1 of 4)	65
Figure 1-97	Reinstall the control-panel assembly to keyboard FFC (2 of 4)	66
Figure 1-98	Reinstall the control-panel assembly to keyboard FFC (3 of 4)	66
Figure 1-99	Reinstall the control-panel assembly to keyboard FFC (4 of 4)	67
Figure 1-100	Remove the keyboard assembly (1 of 7)	68
Figure 1-101	Remove the keyboard assembly (2 of 7)	69
Figure 1-102	Remove the keyboard assembly (3 of 7)	69
Figure 1-103	Remove the keyboard assembly (4 of 7)	70
Figure 1-104	Remove the keyboard assembly (5 of 7)	70
Figure 1-105	Remove the keyboard assembly (6 of 7)	71
Figure 1-106	Remove the keyboard assembly (7 of 7)	71
Figure 1-107	Install a keyboard overlay (1 of 6)	72
Figure 1-108	Install a keyboard overlay (2 of 6)	72
Figure 1-109	Install a keyboard overlay (3 of 6)	73
Figure 1-110	Install a keyboard overlay (4 of 6)	73
Figure 1-111	Install a keyboard overlay (5 of 6)	74
Figure 1-112	Install a keyboard overlay (6 of 6)	75
Figure 1-113	Remove the back-side background selector assembly (1 of 3)	76
Figure 1-114	Remove the back-side background selector assembly (2 of 3)	76

Figure 1-115	Remove the back-side background selector assembly (3 of 3)	77
Figure 1-116	Remove the right door; optional paper feeder (1 of 3)	78
Figure 1-117	Remove the right door; optional paper feeder (2 of 3)	78
Figure 1-118	Remove the right door; optional paper feeder (3 of 3)	79
Figure 1-119	External panels, covers, doors, and scanner assembly; identification and location	80
Figure 1-120	Remove USB cover	81
Figure 1-121	Remove the HIP cover	82
Figure 1-122	Remove the front-upper cover (1 of 4)	83
Figure 1-123	Remove the front-upper cover (2 of 4)	83
Figure 1-124	Remove the front-upper cover (3 of 4)	84
Figure 1-125	Remove the front-upper cover (4 of 4)	84
Figure 1-126	Remove the stapler cover	85
Figure 1-127	Remove the right-door assembly (1 of 8)	86
Figure 1-128	Remove the right-door assembly (2 of 8)	86
Figure 1-129	Remove the right-door assembly (3 of 8)	87
Figure 1-130	Remove the right-door assembly (4 of 8)	87
Figure 1-131	Remove the right-door assembly (5 of 8)	88
Figure 1-132	Remove the right-door assembly (6 of 8)	88
Figure 1-133	Remove the right-door assembly (7 of 8)	89
Figure 1-134	Remove the right-door assembly (8 of 8)	89
Figure 1-135	Remove the right-rear cover (1 of 3)	90
Figure 1-136	Remove the right-rear cover (2 of 3)	90
Figure 1-137	Remove the right-rear cover (3 of 3)	91
Figure 1-138	Remove the left cover (1 of 5)	92
Figure 1-139	Remove the left cover (2 of 5)	92
Figure 1-140	Remove the left cover (3 of 5)	93
Figure 1-141	Remove the left cover (4 of 5)	93
Figure 1-142	Remove the left cover (5 of 5)	94
Figure 1-143	Remove the rear-upper cover (1 of 3)	95
Figure 1-144	Remove the rear-upper cover (2 of 3)	95
Figure 1-145	Remove the rear-upper cover (3 of 3)	96
Figure 1-146	Remove the left-upper cover	97
Figure 1-147	Remove the rear cover (1 of 2)	98
Figure 1-148	Remove the rear cover (2 of 2)	99
Figure 1-149	Remove the right-front cover (1 of 5)	100
Figure 1-150	Remove the right-front cover (2 of 5)	101
Figure 1-151	Remove the right-front cover (3 of 5)	101
Figure 1-152	Remove the right-front cover (4 of 5)	102
Figure 1-153	Remove the right-front cover (5 of 5)	102
Figure 1-154	Reinstall the power button	103
Figure 1-155	Remove the delivery cover (1 of 3)	104

Figure 1-156	Remove the delivery cover (2 of 3)	105
Figure 1-157	Remove the delivery cover (3 of 3)	105
Figure 1-158	Remove the right-top cover (1 of 2)	106
Figure 1-159	Remove the right-top cover (2 of 2)	107
Figure 1-160	Remove the upper-right cover (1 of 2)	108
Figure 1-161	Remove the upper-right cover (2 of 2)	109
Figure 1-162	Remove the front-top cover (1 of 2)	110
Figure 1-163	Remove the front-top cover (2 of 2)	111
Figure 1-164	Remove the rear-top cover (1 of 2)	112
Figure 1-165	Remove the rear-top cover (2 of 2)	113
Figure 1-166	Remove the document feeder front cover (1 of 4)	114
Figure 1-167	Remove the document feeder front cover (2 of 4)	114
Figure 1-168	Remove the document feeder front cover (3 of 4)	115
Figure 1-169	Remove the document feeder front cover (4 of 4)	115
Figure 1-170	Remove the document feeder rear cover (1 of 4)	116
Figure 1-171	Remove the document feeder rear cover (2 of 4)	116
Figure 1-172	Remove the document feeder rear cover (3 of 4)	117
Figure 1-173	Remove the document feeder rear cover (4 of 4)	117
Figure 1-174	Remove the deskew mylar and separation mylar (1 of 3)	118
Figure 1-175	Remove the deskew mylar and separation mylar (2 of 3)	118
Figure 1-176	Remove the deskew mylar and separation mylar (3 of 3)	119
Figure 1-177	Remove the document feeder tray extender (1 of 2)	120
Figure 1-178	Remove the document feeder tray extender (2 of 2)	120
Figure 1-179	Remove the document feeder jam-access cover (1 of 5)	121
Figure 1-180	Remove the document feeder jam-access cover (2 of 5)	121
Figure 1-181	Remove the document feeder jam-access cover (3 of 5)	122
Figure 1-182	Remove the document feeder jam-access cover (4 of 5)	122
Figure 1-183	Remove the document feeder jam-access cover (5 of 5)	123
Figure 1-184	Remove the document feeder roller cover (1 of 4)	124
Figure 1-185	Remove the document feeder roller cover (2 of 4)	124
Figure 1-186	Remove the document feeder roller cover (3 of 4)	125
Figure 1-187	Remove the document feeder roller cover (4 of 4)	125
Figure 1-188	Reinstall the document feeder roller cover	126
Figure 1-189	Remove the document feeder assembly (1 of 2)	127
Figure 1-190	Remove the document feeder assembly (2 of 2)	128
Figure 1-191	Remove the document feeder assembly (M575c model; 1 of 2)	130
Figure 1-192	Remove the document feeder assembly (M575c model; 2 of 2)	131
Figure 1-193	Remove the document feeder hinge assembly	132
Figure 1-194	Remove the SCB (1 of 2)	133
Figure 1-195	Remove the SCB (2 of 2)	134
Figure 1-196	Reinstalling the SCB	135

Figure 1-197	Remove the SCB (1 of 2)	136
Figure 1-198	Remove the SCB (2 of 2)	137
Figure 1-199	Reinstalling the SCB	138
Figure 1-200	Remove the scanner assembly (1 of 5)	139
Figure 1-201	Remove the scanner assembly (2 of 5)	140
Figure 1-202	Remove the scanner assembly (3 of 5)	140
Figure 1-203	Remove the scanner assembly (4 of 5)	141
Figure 1-204	Remove the scanner assembly (5 of 5)	141
Figure 1-205	Transfer the control-panel cable (1 of 7)	142
Figure 1-206	Transfer the control-panel cable (2 of 7)	143
Figure 1-207	Transfer the control-panel cable (3 of 7)	143
Figure 1-208	Transfer the control-panel cable (4 of 7)	144
Figure 1-209	Transfer the control-panel cable (5 of 7)	144
Figure 1-210	Transfer the control-panel cable (6 of 7)	145
Figure 1-211	Transfer the control-panel cable (7 of 7)	145
Figure 1-212	Remove the stapler assembly	147
Figure 1-213	Remove the ICB (1 of 3)	148
Figure 1-214	Remove the ICB (2 of 3)	149
Figure 1-215	Remove the ICB (3 of 3)	149
Figure 1-216	Remove the DC controller PCA and tray (1 of 4)	150
Figure 1-217	Remove the DC controller PCA and tray (2 of 4)	151
Figure 1-218	Remove the DC controller PCA and tray (3 of 4)	151
Figure 1-219	Remove the DC controller PCA and tray (4 of 4)	152
Figure 1-220	Remove the LVPS (1 of 8)	153
Figure 1-221	Remove the LVPS (2 of 8)	154
Figure 1-222	Remove the LVPS (3 of 8)	154
Figure 1-223	Remove the LVPS (4 of 8)	155
Figure 1-224	Remove the LVPS (5 of 8)	155
Figure 1-225	Remove the LVPS (6 of 8)	156
Figure 1-226	Remove the LVPS (7 of 8)	156
Figure 1-227	Remove the LVPS (8 of 8)	157
Figure 1-228	Remove the delivery fan, cartridge fan, and environmental sensor (1 of 9)	158
Figure 1-229	Remove the delivery fan, cartridge fan, and environmental sensor (2 of 9)	159
Figure 1-230	Remove the delivery fan, cartridge fan, and environmental sensor (3 of 9)	159
Figure 1-231	Remove the delivery fan, cartridge fan, and environmental sensor (4 of 9)	160
Figure 1-232	Remove the delivery fan, cartridge fan, and environmental sensor (5 of 9)	160
Figure 1-233	Remove the delivery fan, cartridge fan, and environmental sensor (6 of 9)	161
Figure 1-234	Remove the delivery fan, cartridge fan, and environmental sensor (7 of 9)	161
Figure 1-235	Remove the delivery fan, cartridge fan, and environmental sensor (8 of 9)	162
Figure 1-236	Remove the delivery fan, cartridge fan, and environmental sensor (9 of 9)	162
Figure 1-237	Remove the toner-collection sensor (1 of 4)	163

Figure 1-238	Remove the toner-collection sensor (2 of 4)	164
Figure 1-239	Remove the toner-collection sensor (3 of 4)	164
Figure 1-240	Remove the toner-collection sensor (4 of 4)	165
Figure 1-241	Remove the residual-toner-feed motor (1 of 7)	166
Figure 1-242	Remove the residual-toner-feed motor (2 of 7)	167
Figure 1-243	Remove the residual-toner-feed motor (3 of 7)	167
Figure 1-244	Remove the residual-toner-feed motor (4 of 7)	168
Figure 1-245	Remove the residual-toner-feed motor (5 of 7)	168
Figure 1-246	Remove the residual-toner-feed motor (6 of 7)	169
Figure 1-247	Remove the residual-toner-feed motor (7 of 7)	169
Figure 1-248	Reinstall the residual-toner collection door	170
Figure 1-249	Remove the transfer roller (1 of 3)	171
Figure 1-250	Remove the secondary transfer assembly (2 of 3)	171
Figure 1-251	Remove the secondary transfer assembly (3 of 3)	172
Figure 1-252	Reinstall the secondary transfer assembly	172
Figure 1-253	Remove the lower pickup guide (1 of 4)	173
Figure 1-254	Remove the lower pickup guide (2 of 4)	174
Figure 1-255	Remove the lower pickup guide (3 of 4)	175
Figure 1-256	Remove the lower pickup guide (4 of 4)	176
Figure 1-257	Remove the RD sensor assembly (1 of 6)	177
Figure 1-258	Remove the RD sensor assembly (2 of 6)	178
Figure 1-259	Remove the RD sensor assembly (3 of 6)	178
Figure 1-260	Remove the RD sensor assembly (4 of 6)	179
Figure 1-261	Remove the RD sensor assembly (5 of 6)	179
Figure 1-262	Remove the RD sensor assembly (6 of 6)	180
Figure 1-263	Remove the power-supply fan (1 of 4)	181
Figure 1-264	Remove the power-supply fan (2 of 4)	182
Figure 1-265	Remove the power-supply fan (3 of 4)	182
Figure 1-266	Remove the power-supply fan (4 of 4)	183
Figure 1-267	Remove the registration assembly (1 of 8)	184
Figure 1-268	Remove the registration assembly (2 of 8)	185
Figure 1-269	Remove the registration assembly (3 of 8)	185
Figure 1-270	Remove the registration assembly (4 of 8)	186
Figure 1-271	Remove the registration assembly (5 of 8)	186
Figure 1-272	Remove the registration assembly (6 of 8)	187
Figure 1-273	Remove the registration assembly (7 of 8)	187
Figure 1-274	Remove the registration assembly (8 of 8)	188
Figure 1-275	Remove the high-voltage power supply lower (1 of 4)	189
Figure 1-276	Remove the high-voltage power supply lower (2 of 4)	190
Figure 1-277	Remove the high-voltage power supply lower (3 of 4)	190
Figure 1-278	Remove the high-voltage power supply lower (4 of 4)	191

Figure 1-279	Reinstall the high-voltage power supply lower	191
Figure 1-280	Remove the developing-disengagement motor (1 of 2)	192
Figure 1-281	Remove the developing-disengagement motor (2 of 2)	193
Figure 1-282	Remove the pickup motor	194
Figure 1-283	Remove the lifter-drive assembly (1 of 2)	195
Figure 1-284	Remove the lifter-drive assembly (2 of 2)	196
Figure 1-285	Remove the tray-pickup drive assembly (1 of 10)	197
Figure 1-286	Remove the tray-pickup drive assembly (2 of 10)	198
Figure 1-287	Remove the tray-pickup drive assembly (3 of 10)	198
Figure 1-288	Remove the tray-pickup drive assembly (4 of 10)	199
Figure 1-289	Remove the tray-pickup drive assembly (5 of 10)	199
Figure 1-290	Remove the tray-pickup drive assembly (6 of 10)	200
Figure 1-291	Remove the tray-pickup drive assembly (7 of 10)	200
Figure 1-292	Remove the tray-pickup drive assembly (8 of 10)	201
Figure 1-293	Remove the tray-pickup drive assembly (9 of 10)	201
Figure 1-294	Remove the tray-pickup drive assembly (10 of 10)	202
Figure 1-295	Reinstall the tray-pickup drive assembly (1 of 3)	202
Figure 1-296	Reinstall the tray-pickup drive assembly (2 of 3)	203
Figure 1-297	Reinstall the tray-pickup drive assembly (3 of 3)	203
Figure 1-298	Remove the tray-pickup assembly (1 of 3)	204
Figure 1-299	Remove the tray-pickup assembly (2 of 3)	205
Figure 1-300	Remove the tray-pickup assembly (3 of 3)	205
Figure 1-301	Remove the laser/scanner assembly (Y/M) (1 of 12)	206
Figure 1-302	Remove the laser/scanner assembly (Y/M) (2 of 12)	207
Figure 1-303	Remove the laser/scanner assembly (Y/M) (3 of 12)	207
Figure 1-304	Remove the laser/scanner assembly (Y/M) (4 of 12)	208
Figure 1-305	Remove the laser/scanner assembly (Y/M) (5 of 12)	208
Figure 1-306	Remove the laser/scanner assembly (Y/M) (6 of 12)	209
Figure 1-307	Remove the laser/scanner assembly (Y/M) (7 of 12)	209
Figure 1-308	Remove the laser/scanner assembly (Y/M) (8 of 12)	210
Figure 1-309	Remove the laser/scanner assembly (Y/M) (9 of 12)	210
Figure 1-310	Remove the laser/scanner assembly (Y/M) (10 of 12)	211
Figure 1-311	Remove the laser/scanner assembly (Y/M) (11 of 12)	211
Figure 1-312	Remove the laser/scanner assembly (Y/M) (12 of 12)	212
Figure 1-313	Remove the laser/scanner assembly (C/Bk) (1 of 7)	214
Figure 1-314	Remove the laser/scanner assembly (C/Bk) (2 of 7)	214
Figure 1-315	Remove the laser/scanner assembly (C/Bk) (3 of 7)	215
Figure 1-316	Remove the laser/scanner assembly (C/Bk) (4 of 7)	215
Figure 1-317	Remove the laser/scanner assembly (C/Bk) (5 of 7)	216
Figure 1-318	Remove the laser/scanner assembly (C/Bk) (6 of 7)	217
Figure 1-319	Remove the laser/scanner assembly (C/Bk) (7 of 7)	218

Figure 1-320	Reinstall the PGC actuators (1 of 5)	218
Figure 1-321	Reinstall the PGC actuators (2 of 5)	219
Figure 1-322	Reinstall the PGC actuators (3 of 5)	219
Figure 1-323	Reinstall the PGC actuators (4 of 5)	220
Figure 1-324	Reinstall the PGC actuators (5 of 5)	220
Figure 1-325	Remove the high-voltage power supply upper (1 of 5)	221
Figure 1-326	Remove the high-voltage power supply upper (2 of 5)	222
Figure 1-327	Remove the high-voltage power supply upper (3 of 5)	222
Figure 1-328	Remove the high-voltage power supply upper (4 of 5)	223
Figure 1-329	Remove the high-voltage power supply upper (5 of 5)	223
Figure 1-330	Reinstall the high-voltage power supply upper	224
Figure 1-331	Remove the drum motor 1	225
Figure 1-332	Remove the drum motor 2 or drum motor 3	226
Figure 1-333	Remove the fuser motor	227
Figure 1-334	Remove the main-drive assembly (1 of 7)	229
Figure 1-335	Remove the main-drive assembly (2 of 7)	229
Figure 1-336	Remove the main-drive assembly (3 of 7)	230
Figure 1-337	Remove the main-drive assembly (4 of 7)	230
Figure 1-338	Remove the main-drive assembly (5 of 7)	231
Figure 1-339	Remove the main-drive assembly (6 of 7)	231
Figure 1-340	Remove the main-drive assembly (7 of 7)	232
Figure 1-341	Reinstall the main-drive assembly (1 of 11)	233
Figure 1-342	Reinstall the main-drive assembly (2 of 11)	233
Figure 1-343	Reinstall the main-drive assembly (3 of 11)	234
Figure 1-344	Reinstall the main-drive assembly (4 of 11)	234
Figure 1-345	Reinstall the main-drive assembly (5 of 11)	235
Figure 1-346	Reinstall the main-drive assembly (6 of 11)	236
Figure 1-347	Reinstall the main-drive assembly (7 of 11)	236
Figure 1-348	Reinstall the main-drive assembly (8 of 11)	237
Figure 1-349	Reinstall the main-drive assembly (9 of 11)	237
Figure 1-350	Reinstall the main-drive assembly (10 of 11)	238
Figure 1-351	Reinstall the main-drive assembly (11 of 11)	238
Figure 1-352	Remove the fuser-drive assembly (1 of 6)	240
Figure 1-353	Remove the fuser-drive assembly (2 of 6)	240
Figure 1-354	Remove the fuser-drive assembly (3 of 6)	241
Figure 1-355	Remove the fuser-drive assembly (4 of 6)	241
Figure 1-356	Remove the fuser-drive assembly (5 of 6)	242
Figure 1-357	Remove the fuser-drive assembly (6 of 6)	242
Figure 1-358	Reinstall the fuser-drive assembly	243
Figure 1-359	Remove the delivery assembly (1 of 5)	245
Figure 1-360	Remove the delivery assembly (2 of 5)	245

Figure 1-361	Remove the delivery assembly (3 of 5)	246
Figure 1-362	Remove the delivery assembly (4 of 5)	246
Figure 1-363	Remove the delivery assembly (5 of 5)	247
Figure 1-364	Reinstall the delivery assembly (1 of 2)	248
Figure 1-365	Reinstall the delivery assembly (2 of 2)	248
Figure 1-366	Remove the duplex-drive assembly (1 of 2)	250
Figure 1-367	Remove the duplex-drive assembly (2 of 2)	250
Figure 1-368	Remove the drawer connector; optional paper feeder	251
Figure 2-1	Base product (no optional trays or accessories)	264
Figure 2-2	Base product (optional trays or accessories)	265
Figure 2-3	External covers, panels, and doors	266
Figure 2-4	Document feeder and scanner assemblies (M575dn and 575f models)	268
Figure 2-5	Document feeder and scanner assemblies (575c models)	270
Figure 2-6	Keyboard and brackets	272
Figure 2-7	Control panel assembly	274
Figure 2-8	ADF assemblies	276
Figure 2-9	Scanner assemblies	278
Figure 2-10	Right-door assembly	280
Figure 2-11	Internal assemblies (1 of 6)	282
Figure 2-12	Internal assemblies (2 of 6)	284
Figure 2-13	Internal assemblies (3 of 6)	286
Figure 2-14	Internal assemblies (4 of 6)	288
Figure 2-15	Internal assemblies (5 of 6)	290
Figure 2-16	Internal assemblies (6 of 6)	292
Figure 2-17	Tray 2	294
Figure 2-18	Paper pickup assembly (Tray 2)	296
Figure 2-19	PCAs	298
Figure 2-20	1 x 500-sheet paper feeder	300
Figure 2-21	Paper feeder covers	302
Figure 2-22	Paper feeder main body	304
Figure 2-23	Paper feeder cassette	306
Figure 2-24	Paper feeder PCA	308

1 Removal and replacement

 **NOTE:** Your product might not appear exactly as the one shown in the photos in this chapter. Although some photos do not show the document feeder and scanner assembly installed, the procedures in this chapter are appropriate for your product.

- [Introduction](#)
- [Removal and replacement strategy](#)
- [Service approach](#)
- [Removal and replacement procedures](#)

Introduction

This chapter describes the removal and replacement of field-replaceable units (FRUs) only.

Replacing FRUs is generally the reverse of removal. Occasionally, notes and tips are included to provide directions for difficult or critical replacement procedures.

HP does *not* support repairing individual subassemblies or troubleshooting to the component level.

Note the length, diameter, color, type, and location of each screw. Be sure to return each screw to its original location during reassembly.

Incorrectly routed or loose wire harnesses can interfere with other internal components and can become damaged or broken. Frayed or pinched harness wires can be difficult to find. When replacing wire harnesses, always use the provided wire loops, lance points, or wire-harness guides and retainers.

Removal and replacement strategy

General cautions during removal and replacement

This chapter describes the removal and replacement of field-replaceable units (FRUs) only.

Replacing FRUs is generally the reverse of removal. Occasionally, notes and tips are included to provide directions for difficult or critical replacement procedures.

HP does *not* support repairing individual subassemblies or troubleshooting to the component level.

 **WARNING!** Turn the product off, wait 5 seconds, and then remove the power cable before attempting to service the product. If this warning is not followed, severe injury can result, in addition to damage to the product. The power must be on for certain functional checks during troubleshooting. However, disconnect the power supply during parts removal.

Never operate or service the product with the protective cover removed from the laser scanner assembly. The reflected beam, although invisible, can damage your eyes.

The sheet-metal parts can have sharp edges. Be careful when handling sheet-metal parts.

 **CAUTION:** Do not bend or fold the flat flexible cables (FFCs) during removal or installation. Also, do not straighten prefolds in the FFCs. You *must* fully seat all FFCs in their connectors. Failure to fully seat an FFC into a connector can cause a short circuit in a PCA.



Incorrectly routed or loose wire harnesses can interfere with other internal components and can become damaged or broken. Frayed or pinched harness wires can be difficult to find. When replacing wire harnesses, always use the provided wire loops, lance points, or wire-harness guides and retainers.

 **NOTE:** To install a self-tapping screw, first turn it counterclockwise to align it with the thread pattern, and then carefully turn it clockwise to tighten. Do not overtighten. If a self-tapping screw-hole becomes stripped, repair the screw-hole or replace the affected assembly.

Note the length, diameter, color, type, and location of each screw. Be sure to return each screw to its original location during reassembly.

 **TIP:** For clarity, some photos in this chapter might show components removed that would not be removed to service the product. If necessary, remove the components listed at the beginning of a procedure before proceeding to service the product.

Electrostatic discharge

 **CAUTION:**  Some parts are sensitive to electrostatic discharge (ESD). Look for the ESD reminder when removing product parts. Always perform service work at an ESD-protected workstation or mat, or use an ESD strap. If an ESD workstation, mat, or strap is not available, ground yourself by touching the sheet-metal chassis *before* touching an ESD-sensitive part.

Protect the ESD-sensitive parts by placing them in ESD pouches when they are out of the product.

Required tools

- #1 Phillips screwdriver with a magnetic tip and a 152-mm (6-inch) shaft length
- #2 Phillips screwdriver with a magnetic tip and a 152-mm (6-inch) shaft length
- Small flat blade screwdriver
- Needle-nose pliers
- ESD mat or ESD strap (if one is available)
- Penlight (optional)

 **CAUTION:** Always use a Phillips screwdriver (callout 1). Do not use a Pozidriv® screwdriver (callout 2) or any motorized screwdriver. These can damage screws or screw threads.

Figure 1-1 Phillips and Pozidriv screwdriver comparison



Types of screws



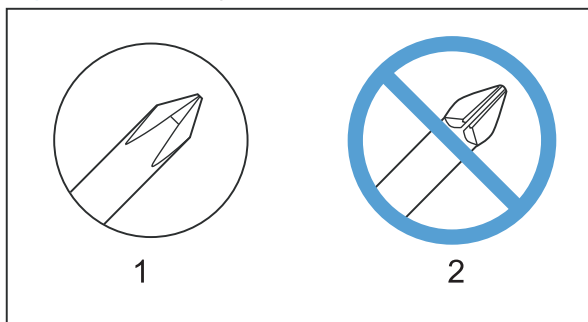



 **NOTE:** The illustration in this section are for reference only. The screws in your product might look slightly different.

Illustration	Description	Size	Part number	Use
	Screw with washer	M3X6	XB2-7300-000CN	Used to secure metal components to metal components (for example, a ground wire to the frame)
	Screw, tapping	M3X6	XA9-1503-000CN	
	Screw	D-M3X6	XA9-1671-000CN	
	Screw	P-M3X8	XB4-5300-807CN	
	Screw, tapping, truss head	M4X10	XB4-7401-005CN	Used to secure anything to plastic

6 mm 8 mm 10 mm M 3 M 4

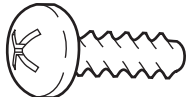

Service approach

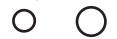
Product repair normally begins by using the product internal diagnostics and the following two-step process:

1. Isolate the problem to the major system (for example, the network or server, or the product).
2. Troubleshoot the problem by using the procedures in the solve problems chapter.

After you find a faulty part, the product can usually be repaired at the assembly level by replacing field-replaceable units (FRUs). Some mechanical assemblies might need to be repaired at the subassembly level.



NOTE: Your product might not appear exactly as the one shown in the photos in this chapter. Although some photos do not show the document feeder and scanner assembly installed, the procedures in this chapter are appropriate for your product.

Before performing service

- Remove all media from the product.
- Turn off the power using the power switch.
- Unplug the power cable and interface cable or cables.
- Place the product on an ESD workstation or mat, or use an ESD strap (if one is available). If an ESD workstation, mat, or strap is not available, ground yourself by touching the sheet-metal chassis *before* touching an ESD-sensitive part.
- Remove the toner cartridges. See [Toner cartridges on page 11](#).
- Remove the tray or trays. See [Tray 2 and 3 on page 23](#).

After performing service

- Plug in the power cable.
- Reinstall the toner cartridges.
- Reinstall the tray or trays.
- If the optional paper feeder was installed, place the product on the feeder.

Post-service test

Perform the following test to verify that the repair or replacement was successful.

Print-quality test

1. Verify that you have completed the necessary reassembly steps.
2. Make sure that the tray contains clean, unmarked paper.
3. Attach the power cord and interface cable or interface cables, and then turn on the product.
4. Verify that the expected startup sounds occur.
5. Print a configuration page, and then verify that the expected printing sounds occur.
6. Print a demo page, and then verify that the print quality is as expected.
7. Send a print job from the host computer, and then verify that the output meets expectations.
8. If necessary, restore any customer-specified settings.
9. Clean the outside of the product with a damp cloth.

Copy-quality test

1. Verify that you have completed the necessary reassembly steps.
2. Ensure that the input tray contains clean, unmarked paper.
3. Attach the power cord, and then turn on the product.
4. Verify that the expected start-up sounds occur.
5. Print a configuration page, and then verify that the expected printing sounds occur.
6. Place the configuration page in the document feeder.
7. Print a copy job, and then verify the results.
8. Place the configuration page on the scanner glass.
9. Print a copy job, and then verify the results.
10. Clean the outside of the product with a damp cloth.

DC controller PCA

Figure 1-2 DC controller PCA

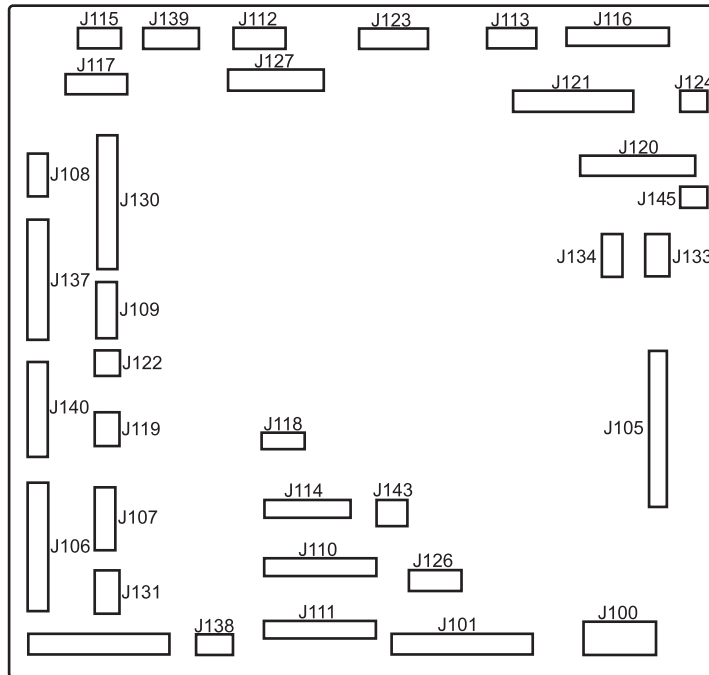

J100: 24 v from low-voltage power supply (LVPS) and interlock	J114: HVPS lower	J126: memory tag connector
J101: LVPS	J115: fuser sensors	J127: pre-exposure LEDs (rear), SR17, SL1
J105: interconnect board (ICB)	J116: HVPS upper	J130: registration density (RD) sensors (front and rear)
J106: 500-sheet feeder, developing home position, laser motors	J117: fuser motor	J131: pickup motor
J107: duplex sensor, tray 1 solenoid, paper present sensor	J118: 5 v interlock	J133: not used
J108: environmental sensor	J119: LVPS fan	J134: not used
J109: duplex clutch, overhead transparency (OHT) in, top-of-page sensor	J120: drum motor 1 and drum motor 2	J137: toner collection unit (TCU) full, TCU motor, toner level detection
J110: YM laser	J121: drum motor 3, drum position 1,2,3	J138: 24 v to HVPS lower
J111: CK laser	J122: OHT out	J139: fuser sensors
J112: pre-exposure LEDs (front)	J123: pressure release, bin full, fuser delivery	J140: lift motor, tray present, stack surface
J113: 24 v to high-voltage power supply (HVPS) upper	J124: 24 v to scanner	J143: 24 v present from LVPS
		J145: 24v to stapler

Parts removal order

Figure 1-3 Parts removal order (1 of 3)

Assembly	Remove	Remove	Remove	Remove	Remove	Remove	Remove	Remove	Remove
Toner cartridges									
Stapler cartridge									
Duplex reverse guide									
Toner collection unit (TCU)									
Formatter									
Hard drive (HDD)	Formatter								
Fax PCA and cable	Formatter								
Tray 2-3 cassettes									
Fuser									
Tray 1 pickup roller	Roller cover								
Tray 2 pickup and separation rollers	Tray 2								
Tray 3 pickup, feed, and separation rollers	Tray 3								
Secondary transfer rollers									
Secondary transfer assembly (T2)									
Intermediate transfer belt (ITB)									
Front-door assembly									
ADF separation pad and ADF separation pad spring									
Control panel									
Keyboard (575c model)	Control panel								
USB cover									
HIP cover									
Front-upper cover									
Stapler cover									
Right-door assembly									
Right-rear cover									
Left cover	Formatter								
Rear-upper cover									
Left-upper cover	Rear-upper cover								
Rear cover	Right-rear cover	Left cover	Rear-upper cover						
Right-front cover	Front-upper cover								
ADF whole unit	Rear-upper cover								
SCB	Rear-upper cover								
Image scanner whole unit	Stapler cover	Rear-upper cover	Left-upper cover	Document feeder	SCB				
Delivery cover	Stapler cover	Front-upper cover	Rear-upper cover	Left-upper cover	Document feeder	SCB	Scanner	Upper-right cover	
Right-top cover	Stapler cover	Rear-upper cover	Left-upper cover	Document feeder	SCB	Scanner			
Upper-right cover	Stapler cover	Rear-upper cover	Left-upper cover	Document feeder	SCB	Scanner			
Front-top cover	Stapler cover	Rear-upper cover	Left-upper cover	Front-upper cover	Left cover	Document feeder	SCB	Scanner	
Rear-top cover	Stapler cover	Rear-upper cover	Left-upper cover	Rear cover	Document feeder	SCB	Scanner	Delivery cover	Front top cover

Figure 1-4 Parts removal order (2 of 3)

Assembly	Remove	Remove
ADF front cover		
ADF rear cover		
Mylar		
Foam reflector		
ADF tray extender		
ADF PCA	ADF rear cover	
ADF jam-access cover		
Roller door	ADF jam-access cover	
Stoppers	ADF jam-access cover	
ADF handle	ADF jam-access cover	
Photosensor	ADF jam-access cover	
ADF tray cover		
Legal flag and sensor	ADF tray cover	
ADF paper guides	ADF tray cover	
Assy hinge	Rear-upper cover	ADF whole unit
ADF pick success sensor assy	Rear-upper cover	ADF whole unit

Figure 1-5 Parts removal order (3 of 3)

Assembly	Remove	Remove	Remove	Remove	Remove	Remove	Remove	Remove	Remove
Stapler assembly	Stapler cover								
Interconnect board (ICB)	TCU	Formatter	Right-rear cover	Left cover	Rear-upper cover	Rear cover			
DC controller (DCC) and tray (optional)	TCU	Formatter	Right-rear cover	Left cover	Rear-upper cover	Rear cover	ICB	LVPS (if removing tray)	
LVPS	TCU	Formatter	Right-rear cover	Left cover	Rear-upper cover	Rear cover	ICB		
Delivery fan, cartridge fan, and environmental sensor	TCU	Left cover							
Toner collection sensor	TCU	Left cover							
Residual-toner feed motor	TCU	ITB	Left cover						
Registration density (RD) sensor	T2	ITB							
Power supply (PS) fan and fan duct	TCU	Right-rear cover	Left cover	Rear-upper cover	Rear cover				
Registration assembly	TCU	T2	ITB	Right-rear cover	Left cover	Rear-upper cover	Rear cover	RD sensor	PS fan and duct
High-voltage power supply (HVPS) lower	TCU Formatter Right-rear cover	ICB	LVPS						
Developing-disengagement motor		ICB	LVPS	HVPS-lower					
Pickup motor		ICB	LVPS	HVPS-lower					
Lifter-drive assembly		ICB	LVPS	HVPS-lower					
Cassette pickup drive assembly		Left cover	ICB	LVPS	HVPS-lower				
Laser scanner (Y/M)		Rear-upper cover	ICB	LVPS	HVPS-lower				
Laser scanner (C/Bk)		Rear cover	ICB	LVPS	HVPS-lower	Lifter-drive	Laser scanner (Y/M)		
Cassette pickup assembly		ICB	LVPS	Registration assembly	HVPS-lower	Cassette-pickup drive assembly			
High-voltage power supply (HVPS) upper	TCU	Rear-upper cover							
Drum motors 1, 2, or 3	Formatter Right-rear cover Left cover	Rear cover ICB DCC LVPS	HVPS-upper						
Fuser motor			HVPS-upper						
Main-drive assembly	TCU Formatter Fuser T2 ITB	Right-rear cover Left cover Rear-upper cover Rear cover	ICB DCC and tray PS fan and duct LVPS HVPS lower and upper						
Fuser-drive assembly			Document feeder SCB Scanner	Main drive					
Delivery assembly	TCU Formatter Fuser T2 ITB Front-upper cover Right-rear cover	Left cover Stapler cover Rear-upper cover Left-upper cover Rear cover	Front-top cover Rear-top cover PS fan and duct ICB	Main drive	Fuser drive				
Duplex-drive assembly			DCC and tray LVPS HVPS lower and upper	Main drive	Fuser drive	Delivery assembly			

Removal and replacement procedures

Customer self repair (CSR) components

 **NOTE:** Your product might not appear exactly as the one shown in the photos in this chapter. Although some photos do not show the document feeder and scanner assembly installed, the procedures in this chapter are appropriate for your product.

Toner cartridges

 **CAUTION:** If toner gets on your clothing, wipe it off with a dry cloth and wash clothing in cold water. *Hot water sets toner into fabric.*

1. Open the front door. Make sure that the door is completely open.

Figure 1-6 Remove the toner cartridge (1 of 2)



2. Grasp the toner-cartridge handle and pull out to remove.

⚠ CAUTION: Do not touch the green roller. Doing so can damage the cartridge. Do not expose the cartridge to strong light. Cover the cartridge with a sheet of paper to protect it from light.

💡 Reinstallation tip Align the toner cartridge with its slot and insert the toner cartridge until it clicks into place.

Figure 1-7 Remove the toner cartridge (2 of 2)

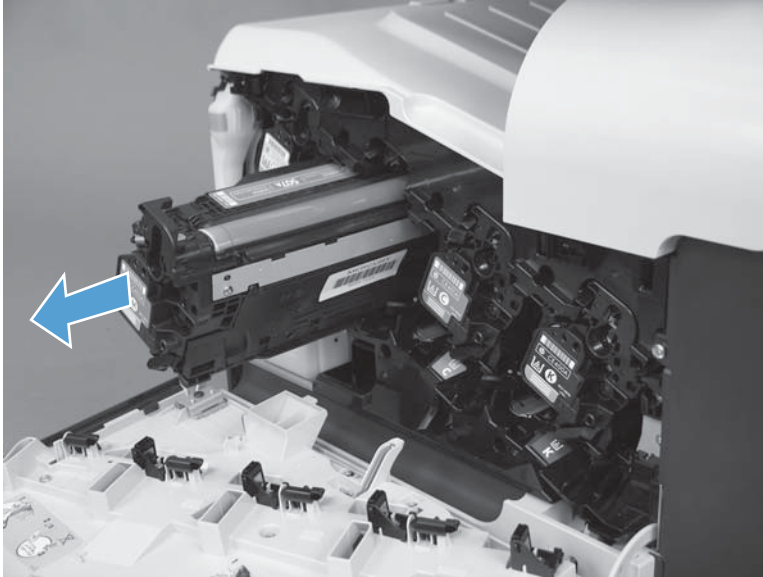

Staple cartridge

Open the stapler door, and then remove the staple cartridge.

Figure 1-8 Remove the staple cartridge

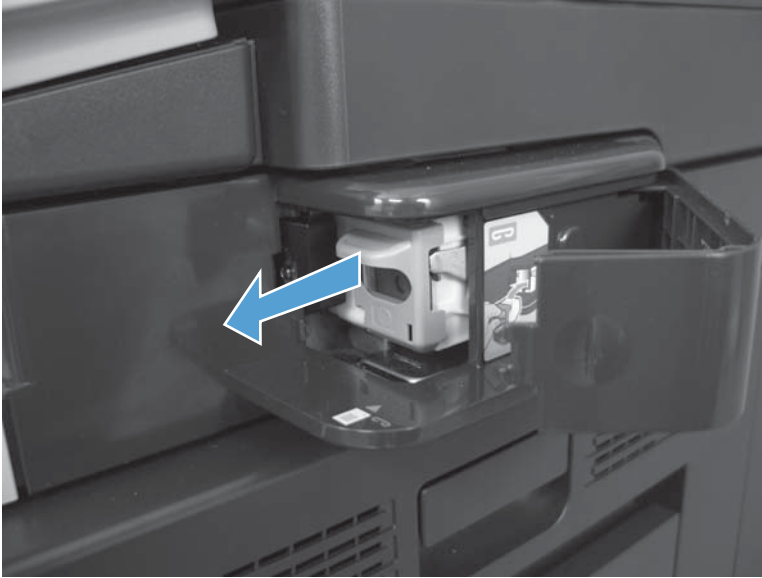

Duplex-reverse guide

1. Grasp the duplex-reverse guide and pull it away from the product to release it.

Figure 1-9 Remove the duplex-reverse guide (1 of 2)

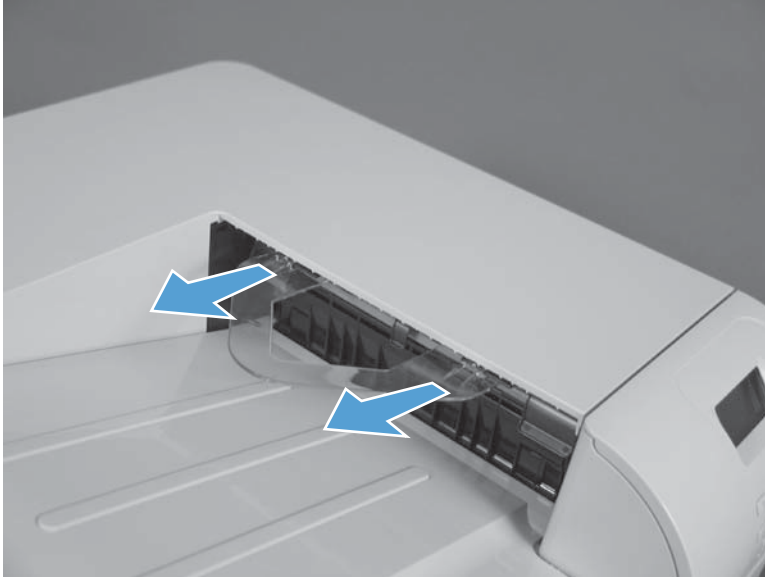

2. Remove the guide.

Figure 1-10 Remove the duplex-reverse guide (2 of 2)



Toner-collection unit

 **NOTE:** The toner-collection unit is designed for a single use. Do not try to empty the toner-collection unit and reuse it. Doing so could cause toner to spill inside the product and result in reduced print quality. For recycling information, see the product user guide.

1. Open the front door. Make sure that the door is completely open.

Figure 1-11 Remove the toner-collection unit (1 of 4)



2. Grasp the blue label at the top of the toner-collection unit and remove it from the product.

 **Reinstallation tip** Insert the bottom of the replacement unit into the product first and then push the top of the unit until it clicks into place. If the toner-collection unit is installed incorrectly, the front door will not close completely.

Figure 1-12 Remove the toner-collection unit (2 of 4)



3. To prevent toner spills, place the blue cap (callout 1) over the blue opening at the top of the unit (callout 2).

Figure 1-13 Remove the toner-collection unit (3 of 4)

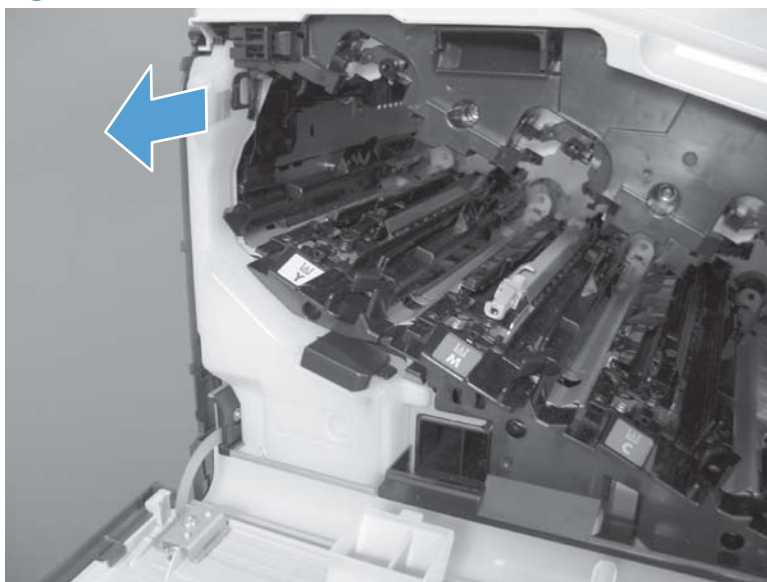

Figure 1-14 Remove the toner-collection unit (4 of 4)

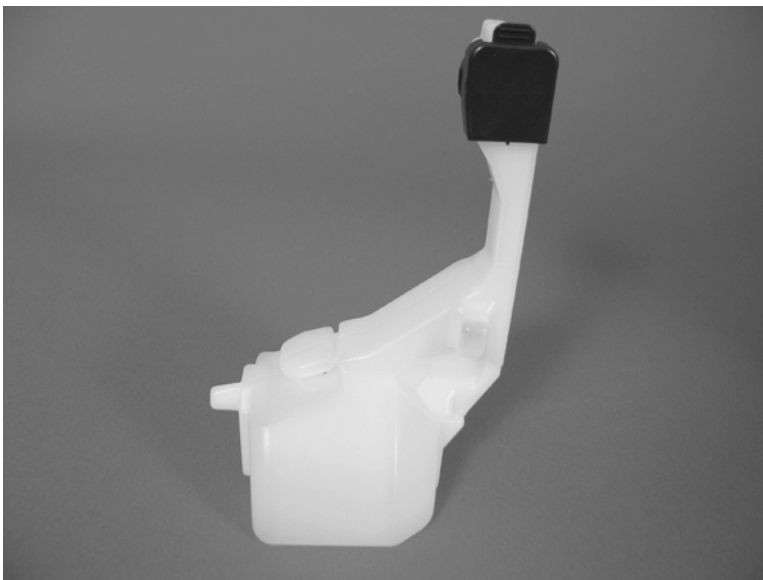



Formatter PCA

CAUTION:  ESD sensitive component.

1. Turn the product off and disconnect the power and interface cable or interface cables.
2. Unscrew the formatter thumb screws, and then firmly pull the formatter from the product. Place the formatter on a clean, flat, grounded surface.

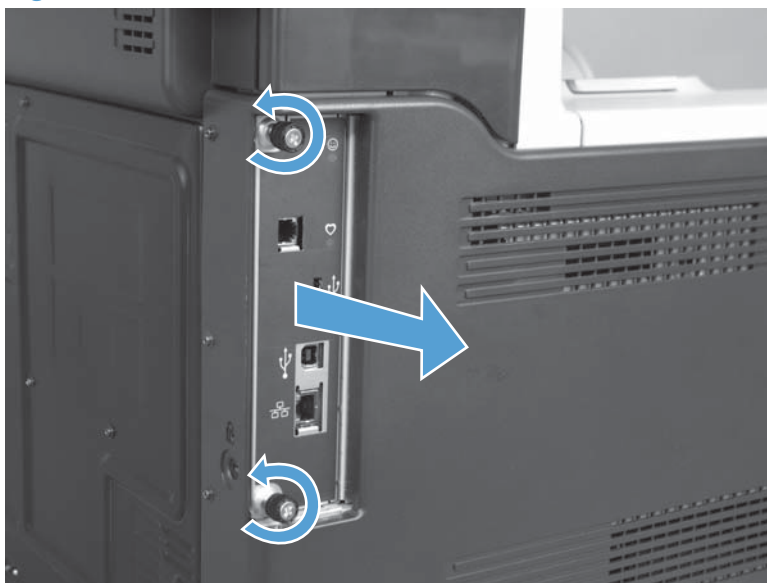
Figure 1-15 Remove the formatter



NOTE:  When reinstalling the formatter, push firmly on the right side to make sure the formatter is seated.

Fax PCA and cable

Before proceeding, remove the following components:

- Formatter PCA. See [Formatter PCA on page 17](#).

Remove the fax PCA and cable

CAUTION:  ESD sensitive component.

1. Disconnect one connector.

Figure 1-16 Remove the fax PCA and cable (1 of 2)

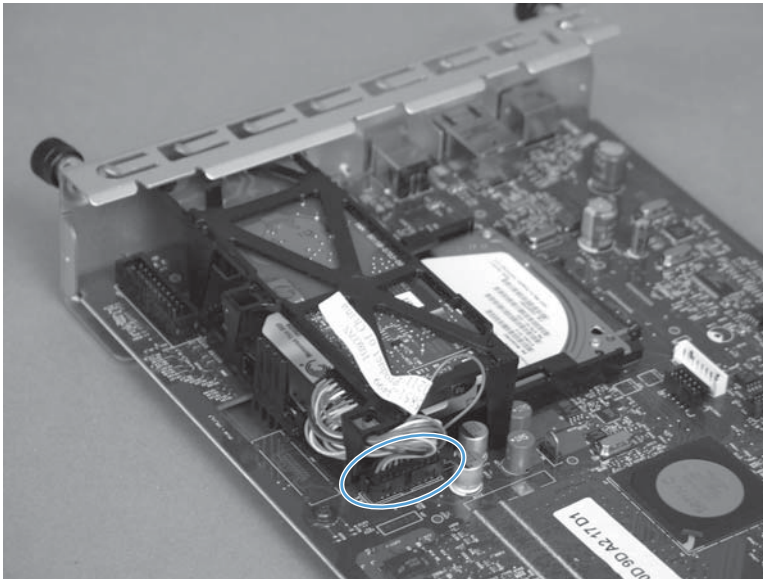

2. Release two tabs and the remove the fax PCA.

 **NOTE:** If necessary, disconnect the cable from the fax PCA.

Figure 1-17 Remove the fax PCA and cable (2 of 2)

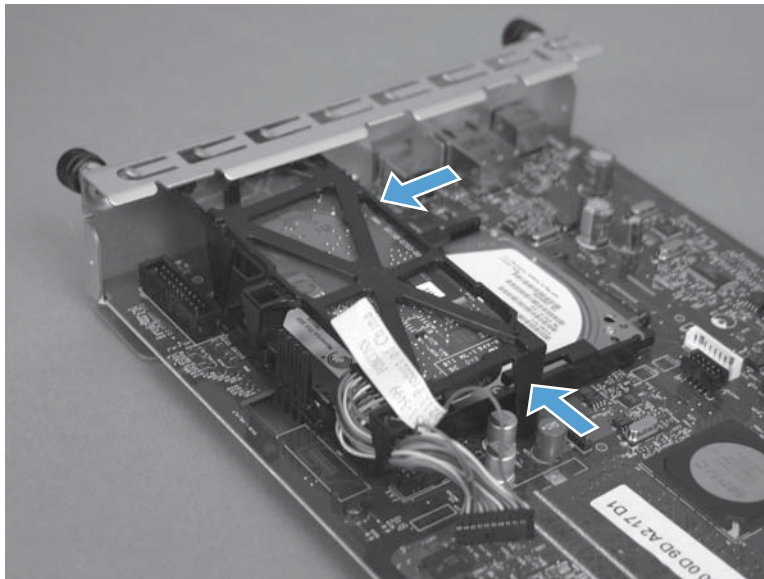

Hard drive

 **NOTE:** The product has a hard disk drive (HDD) installed. If you install a replacement disk drive, you must reload the product firmware. See [Reload the firmware on page 22](#).

Before proceeding, remove the following components:

- Formatter PCA. See [Formatter PCA on page 17](#).
- Fax PCA and cable. See [Fax PCA and cable on page 18](#).

Remove the HDD

 **CAUTION:**  ESD sensitive component.

1. Place the formatter on a clean, flat, grounded surface.
2. Release the locking lever to release the HDD.

Figure 1-18 Remove the HDD (1 of 3)

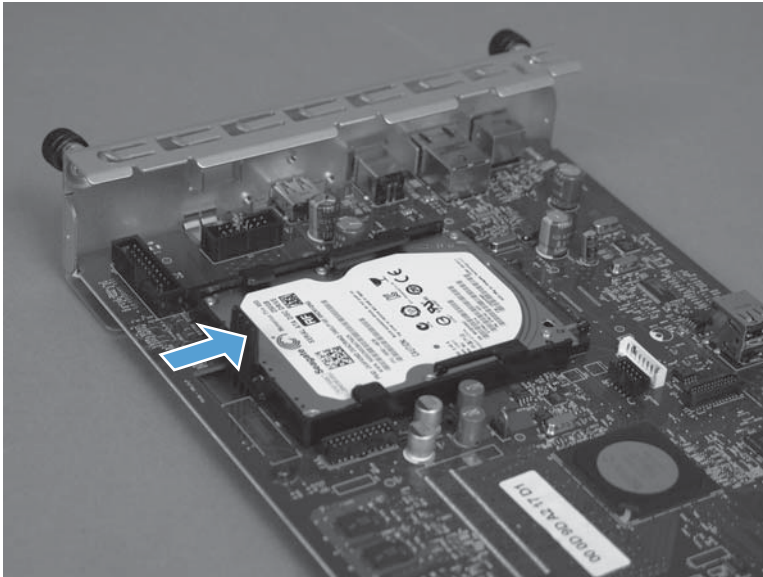

3. Hold the locking lever in the release position, and then slide the HDD toward the edge of the formatter to remove it.

 **Reinstallation tip** When the HDD is reinstalled, make sure that the HDD is fully seated and that the locking lever snaps into the locked position.

Figure 1-19 Remove the HDD (2 of 3)



4. Separate the plastic side rails (callout 1) from the hard drive, and then slide (callout 2) the plastic cover from the hard drive.

 **CAUTION:** The plastic rails can be tight fitting. Remove carefully to avoid breaking.

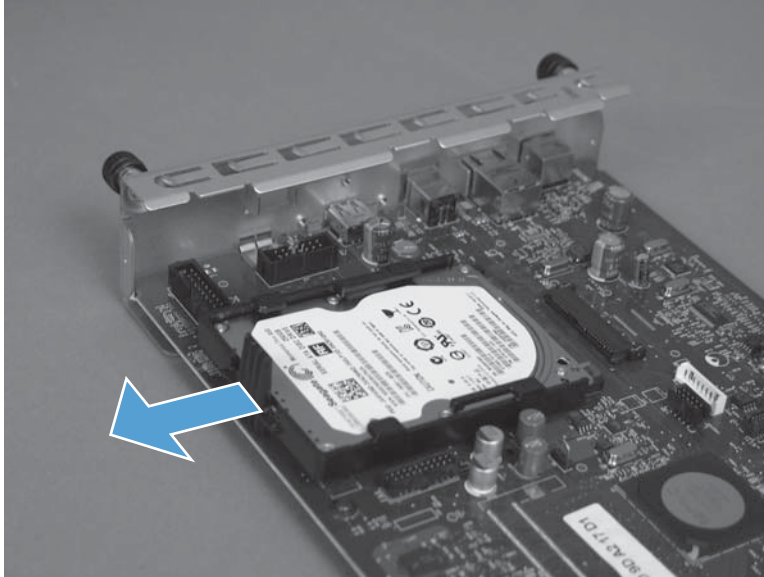
Figure 1-20 Remove the HDD (3 of 3)



Install a replacement hard drive

After installing a replacement hard drive, you must reload the firmware by performing a firmware upgrade.

Reload the firmware

Update firmware

1. Copy the `xxxxxxxxx.bdl` file to a portable USB flash drive.
2. Turn the product on.
3. The HP logo displays on the product control panel. When an underscore displays below the HP logo, touch the logo to open the **Preboot** menu.
4. Touch the down arrow ▼ button to highlight **Administrator**, and then touch the **OK** button.

 **NOTE:** You might be prompted to enter a password to access the **Administrator** menu. Type the password, and then touch the **OK** button.

5. Touch the down arrow ▼ button to highlight **Download**, and then touch the **OK** button.
6. Insert the USB flash drive with the `xxxxxxxxx.bdl` file on it.

 **NOTE:** If the error message **No USB Thumbdrive Files Found** displays on the control-panel display, you might need to connect the storage device to the external USB connection on the formatter or try using a different portable storage device.

7. Touch the down arrow ▼ button to highlight **USB Thumbdrive**, and then touch the **OK** button.
8. Touch the down arrow ▼ button to highlight the `xxxxxxxxx.bdl` file, and then touch the **OK** button.

 **NOTE:** The upgrade process can take up to 10 minutes to complete.

 **TIP:** If there is more than one `xxxxxxxxx.bdl` file on the storage device, make sure that you select the correct file for this product.

9. When the message **Complete** displays on the control-panel display, touch the back arrow ↵ button 3 times.
10. When the message **Continue** displays on the control-panel display, touch the **OK** button. The product will initialize.
11. When the upgrade process is complete, print a configuration page and verify that the upgrade firmware version was installed.

Tray 2 and 3

 **NOTE:** Use this procedure to remove the Tray 2 or optional Tray 3.

1. Pull the tray straight out of the product until it stops.

Figure 1-21 Remove Tray 2 and 3 (1 of 2)

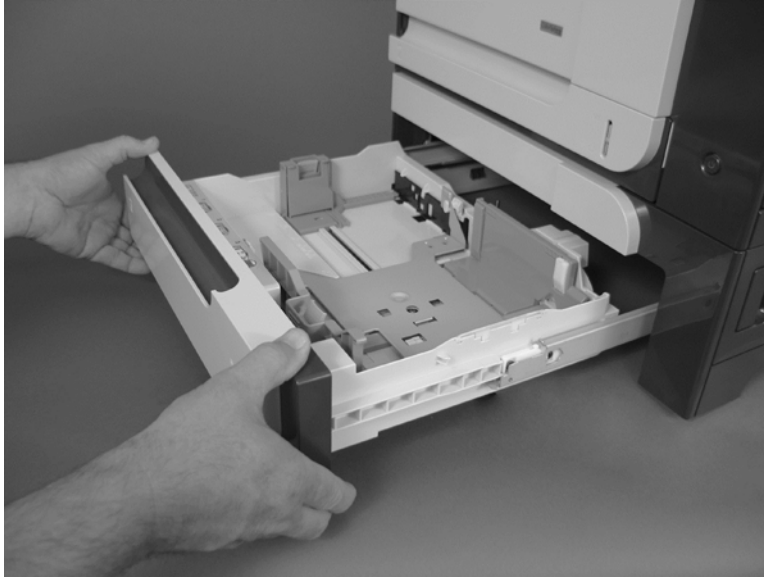

2. Carefully lift up on the tray to release it, and then remove the tray.

Figure 1-22 Remove Tray 2 and 3 (2 of 2)

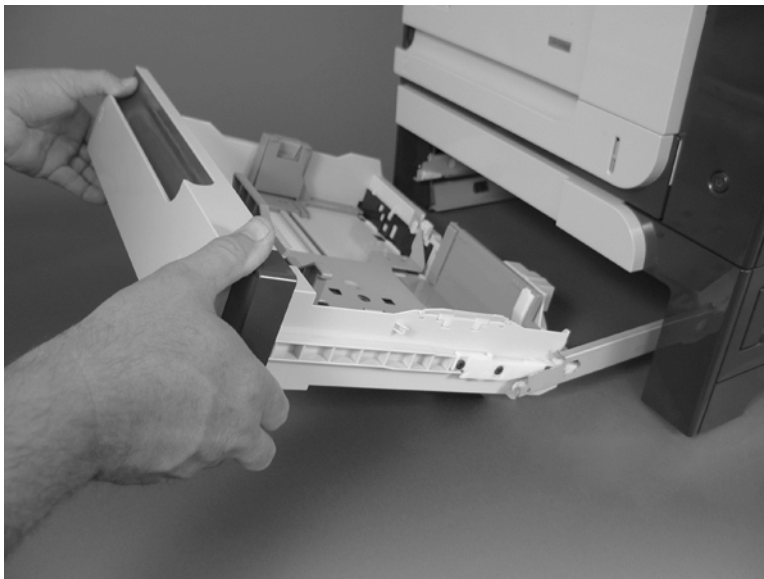

Fuser

CAUTION: The fuser might be hot. Be careful.

1. Open the right-door assembly.

Figure 1-23 Remove the fuser (1 of 2)

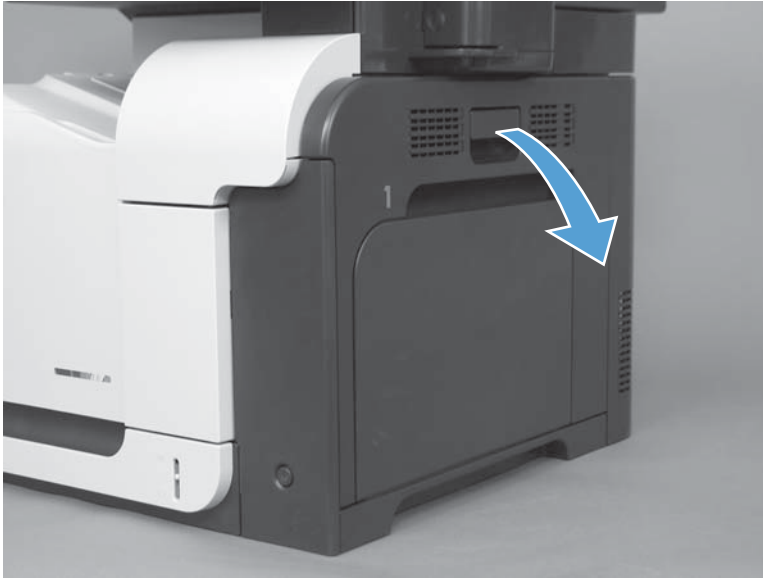

2. Grasp the handles and squeeze the blue release levers.
Pull the fuser straight out of the product to remove it.

Figure 1-24 Remove the fuser (2 of 2)

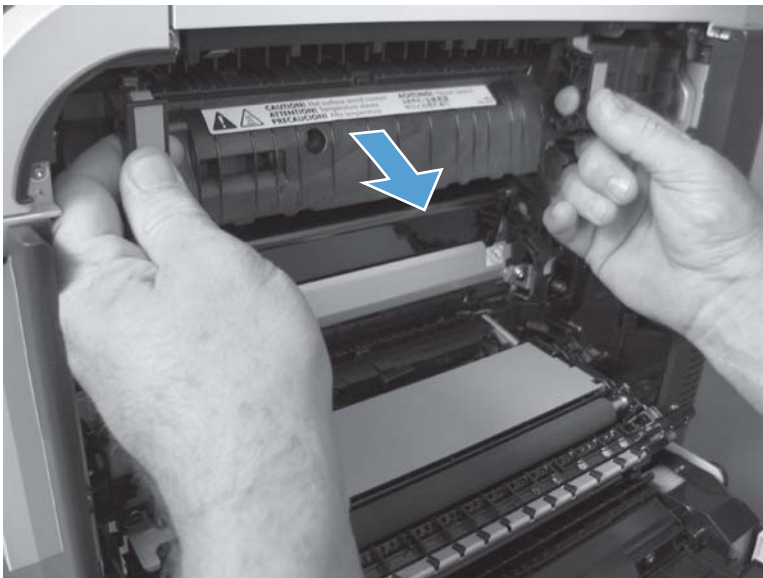

Pickup roller and separation pad (Tray 1)

⚠ CAUTION: Skin oils on the roller or pad can cause paper pickup problems. Wash your hands before removing the roller or pad.

1. Open Tray 1, release two tabs (callout 1), and then rotate the roller cover away from the product to remove it.

💡 TIP: Push down along the top edge of the cover to easily release the tabs.

Figure 1-25 Remove the pickup roller and separation pad (Tray 1; 1 of 3)

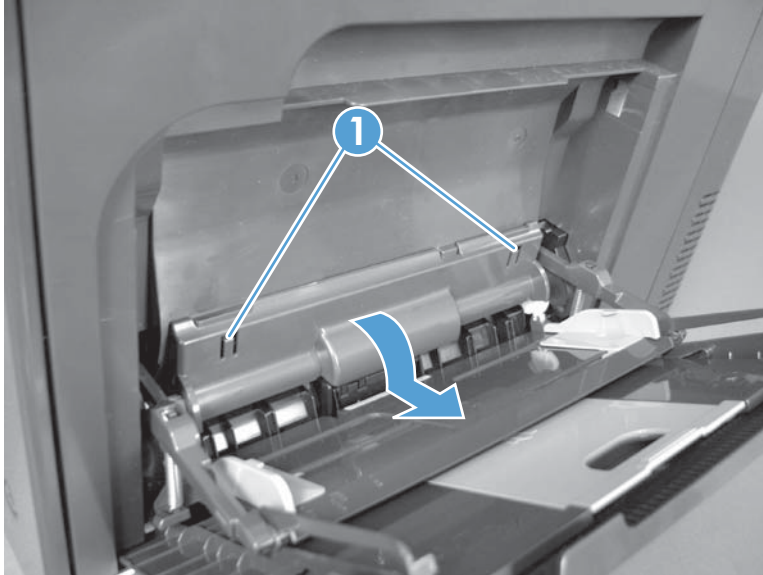

2. Release two tabs and rotate the roller body away from the product to remove it.

Figure 1-26 Remove the pickup roller and separation pad (Tray 1; 2 of 3)

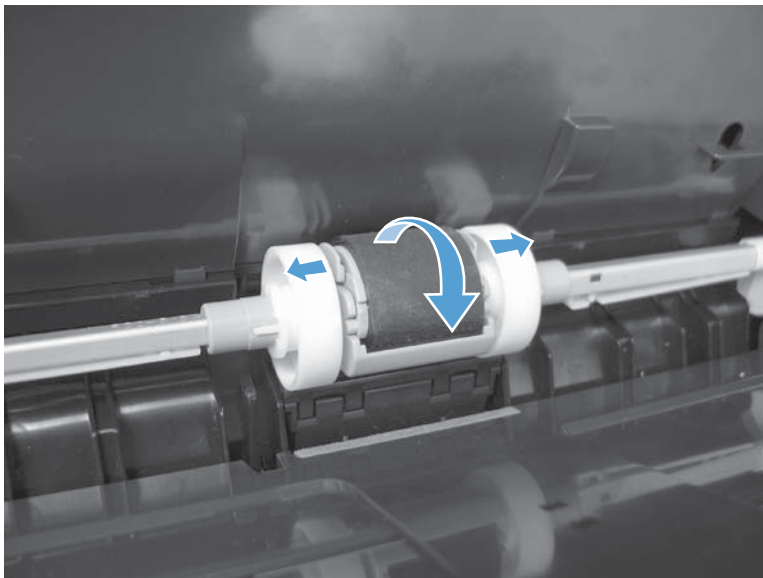

3. Use a small flat blade screwdriver to release two tabs, and then remove the separation pad.

 **TIP:** You might need to slightly depress the spring-loaded separation pad pedestal to remove the pad.

Figure 1-27 Remove the pickup roller and separation pad (Tray 1; 3 of 3)



Pickup roller (Tray 2)

⚠ CAUTION: Skin oils on the roller can cause paper pickup problems. Wash your hands before removing the roller.

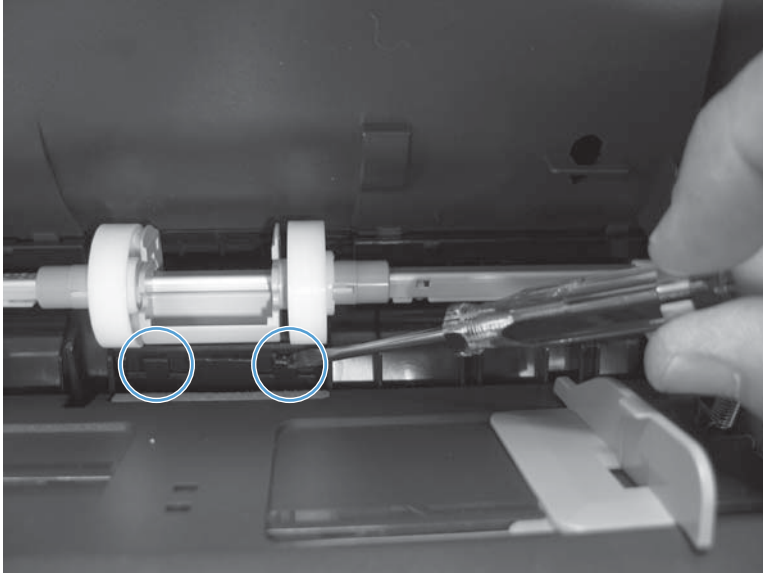
1. Look up into the Tray 2 cavity (where the tray would be installed), and pull down to release the blue roller-locking lever.

💡 Reinstallation tip When the roller is reinstalled, rotate the roller shaft several times to make sure that the shaft correctly engages the drive mechanism. You should hear a click when the shaft engages the drive mechanism.

Figure 1-28 Remove the pickup roller (Tray 2; 1 of 4)

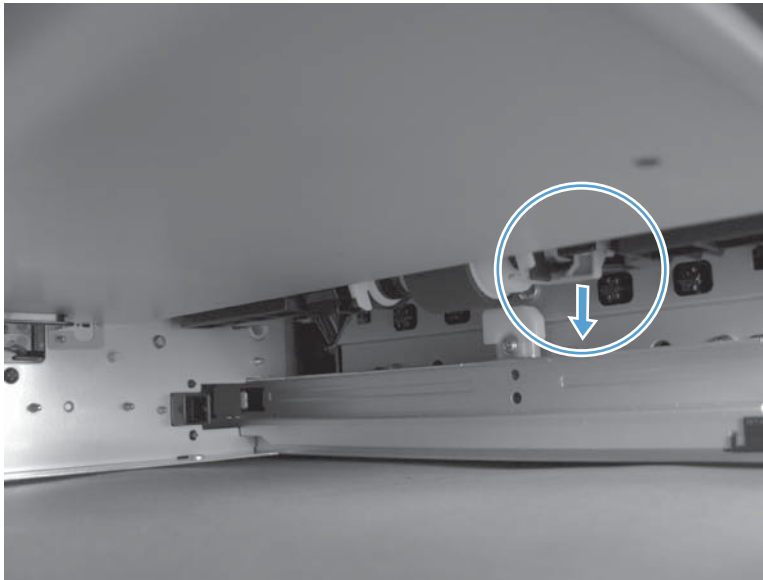

2. Pull the roller toward the front of the product to release the rear of the roller shaft.

Figure 1-29 Remove the pickup roller (Tray 2; 2 of 4)

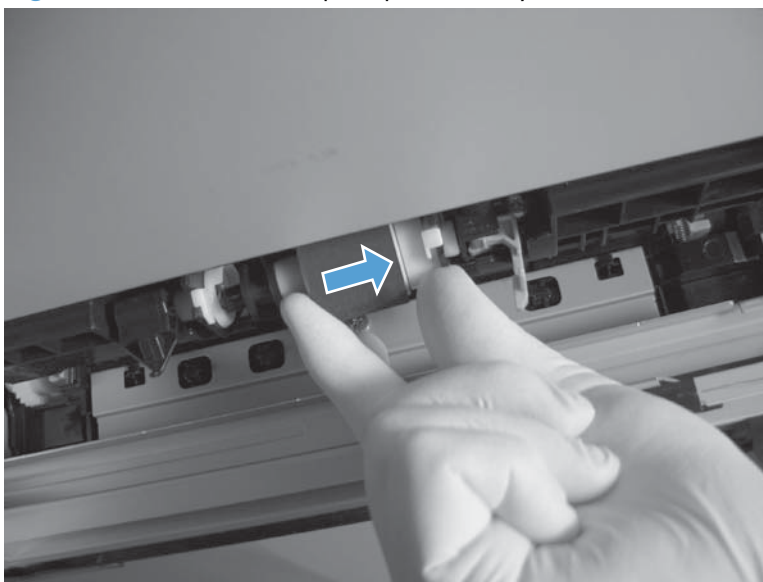

3. Rotate the roller shaft down and away from the product, and then slide the roller toward the rear of the product to release the front of the roller shaft.

Figure 1-30 Remove the pickup roller (Tray 2; 3 of 4)



4. Remove the pickup roller.

 **Reinstallation tip** Make sure that the roller is orientated correctly when it is reinstalled (the large white collar should be positioned toward the front of the product).

Figure 1-31 Remove the pickup roller (Tray 2; 4 of 4)



Pickup and feed rollers (Tray 3)

⚠ CAUTION: Skin oils on the roller can cause paper pickup problems. Wash your hands before removing the rollers.

1. Locate the Tray 3 pickup and feed rollers.

💡 TIP: The feeder is shown front side up in this procedure for clarity. You do not have to separate the product from the feeder to remove these rollers. Remove the tray, and then reach up into the cavity to remove the rollers.

Figure 1-32 Remove the Pickup and feed rollers (Tray 3; 1 of 2)

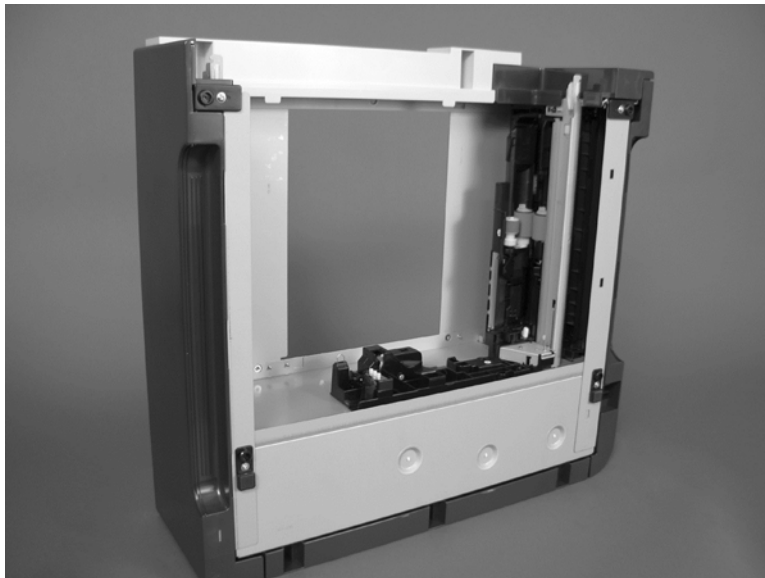

2. Release three tabs (callout 1), and then remove the rollers.

 **Reinstallation tip** When you reinstall the rollers, make sure that the rollers snap into place.

Figure 1-33 Remove the Pickup and feed rollers (Tray 3; 2 of 2)



Separation roller (Tray 2)

⚠ CAUTION: Do not touch the spongy roller surface unless you are replacing the roller. Skin oils on the roller can cause paper pickup problems.

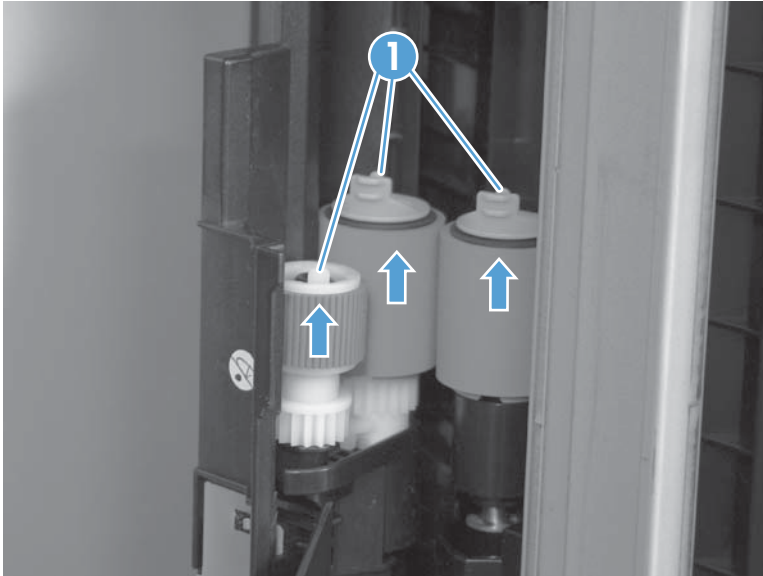
📝 NOTE: Remove the Tray 2 if not already removed for service. See [Tray 2 and 3 on page 23](#).

Remove two screws (callout 1), and then remove the separation roller assembly (callout 2).

Figure 1-34 Remove the separation roller (Tray 2)

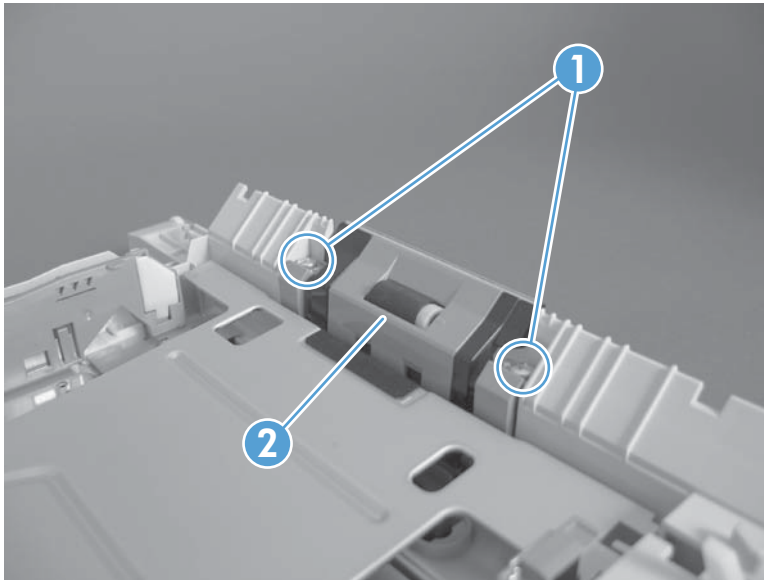

⚠ CAUTION: To install a self-tapping screw, first turn it counterclockwise to align it with the thread pattern, and then carefully turn it clockwise to tighten. Do not overtighten. If a self-tapping screw-hole becomes stripped, repair the screw-hole or replace the affected assembly.

Secondary transfer roller

CAUTION: Do not touch the spongy roller surface unless you are replacing the roller. Skin oils on the roller can cause image quality problems.

1. Open the right-door assembly.

Figure 1-35 Remove the transfer roller (1 of 3)

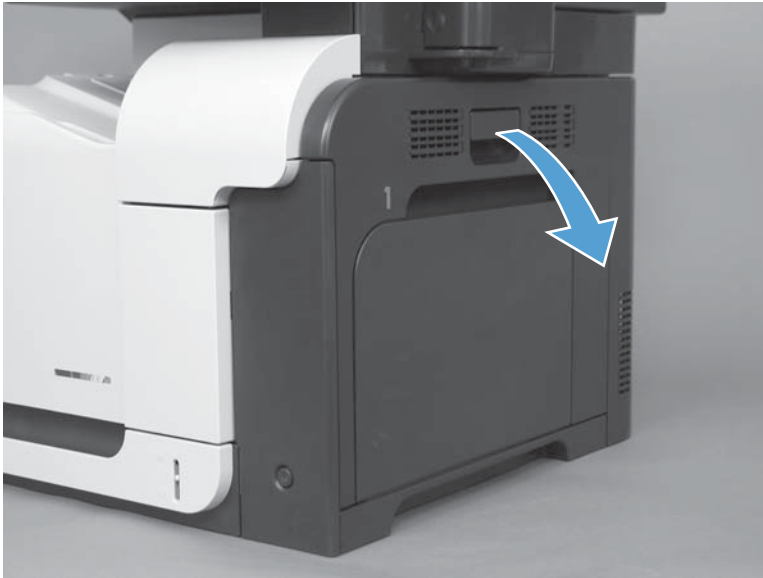

2. Use the blue lever (callout 1) to lower the secondary transfer assembly.

Figure 1-36 Remove the transfer roller (2 of 3)

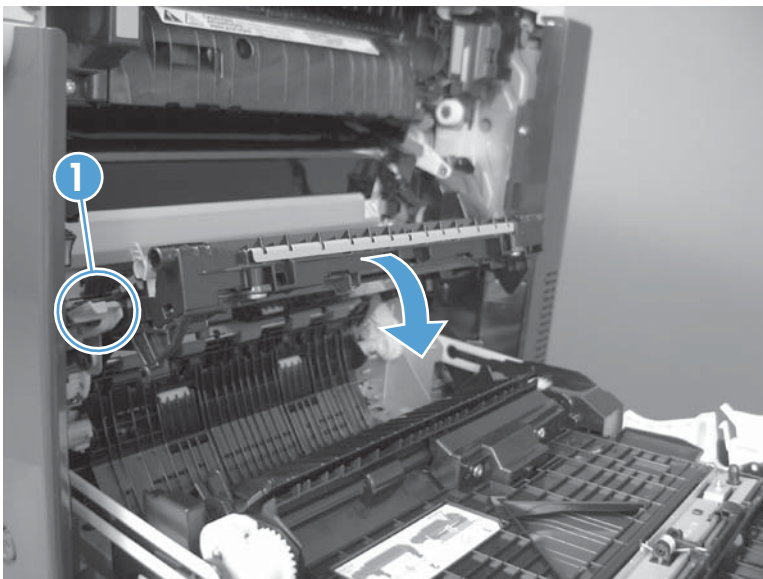

3. Grasp the roller shaft collars, and lift the transfer roller off of the product.

Figure 1-37 Remove the transfer roller (3 of 3)

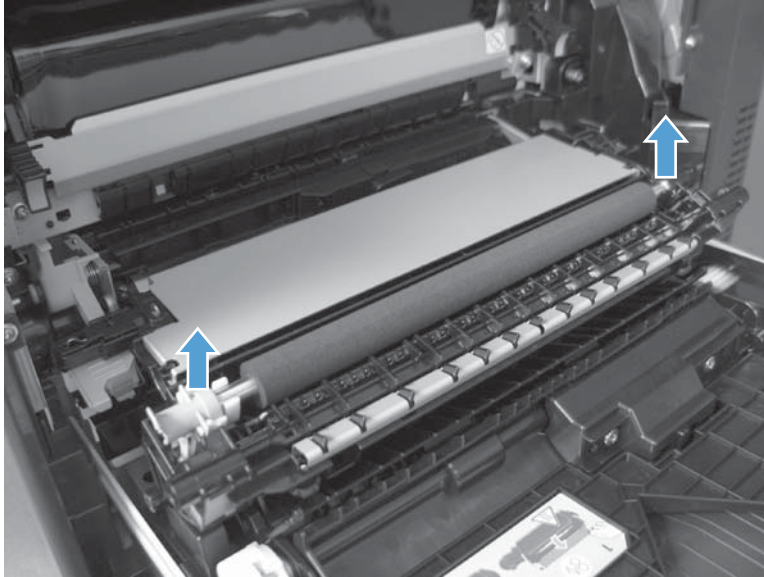

Reinstall the transfer roller

When you reinstall the transfer roller, make sure that the pins on the shaft collars (callout 1) align with the holes in the mounting assembly.

Figure 1-38 Reinstall the transfer roller

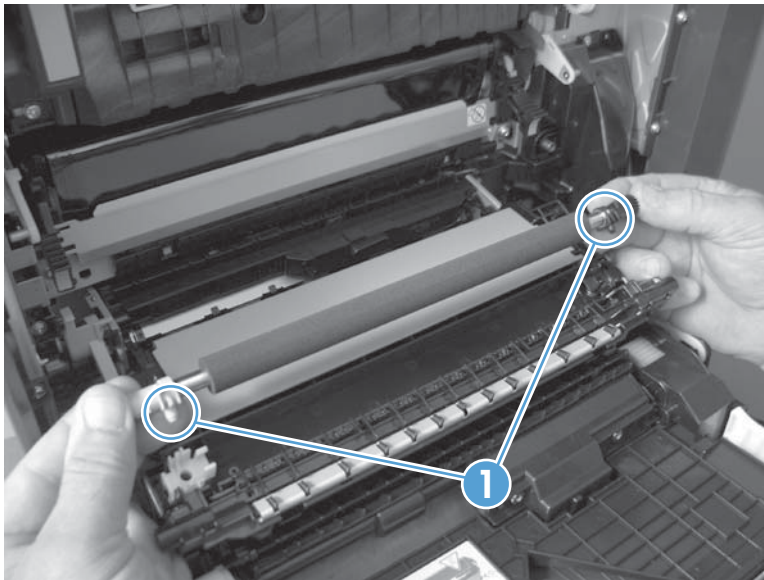

Intermediate transfer belt (ITB)

CAUTION: Do not touch the black-plastic belt. Skin oils and fingerprints on the belt can cause print-quality problems. Always place the ITB on a flat surface in a safe and protected location.

1. Open the right-door assembly.

Figure 1-39 Remove the fuser (1 of 2)

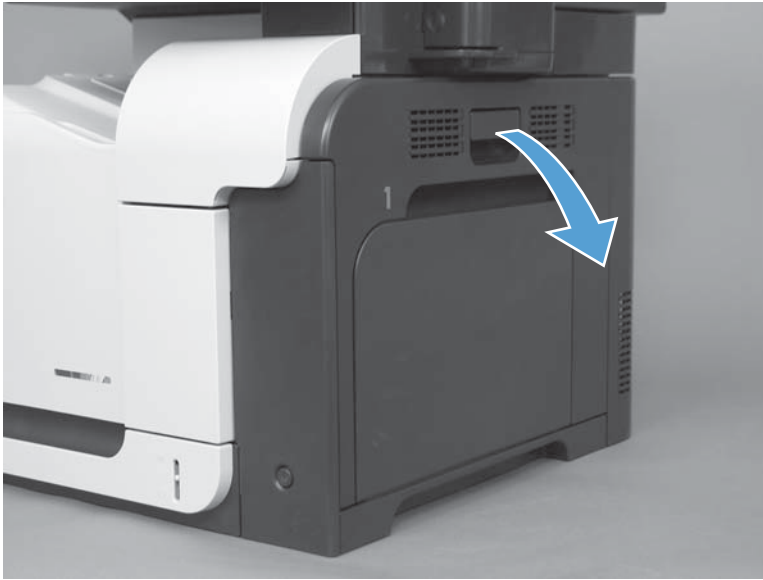

2. Use the blue lever (callout 1) to lower the secondary transfer assembly.

Figure 1-40 Remove the intermediate transfer belt (1 of 3)

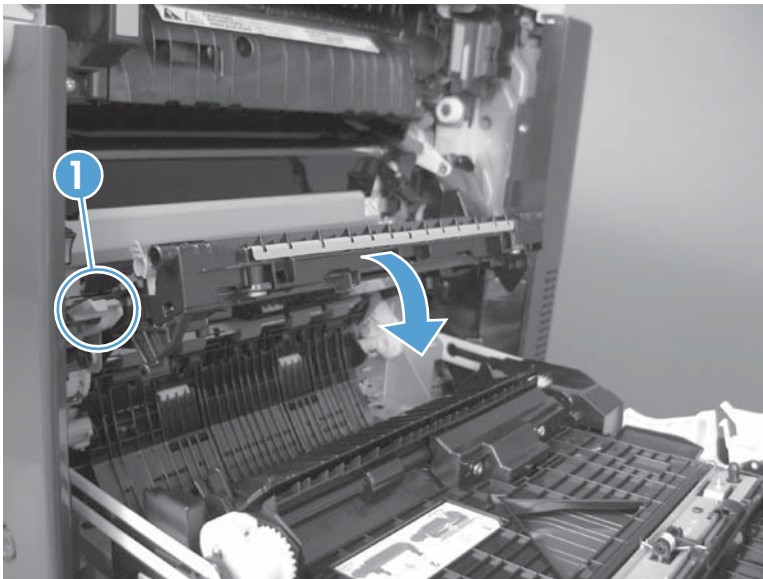

3. Grasp the small handles on the ITB and then pull the ITB out of the product until two large handles expand along the right- and left-side of the ITB.

Figure 1-41 Remove the intermediate transfer belt (2 of 3)

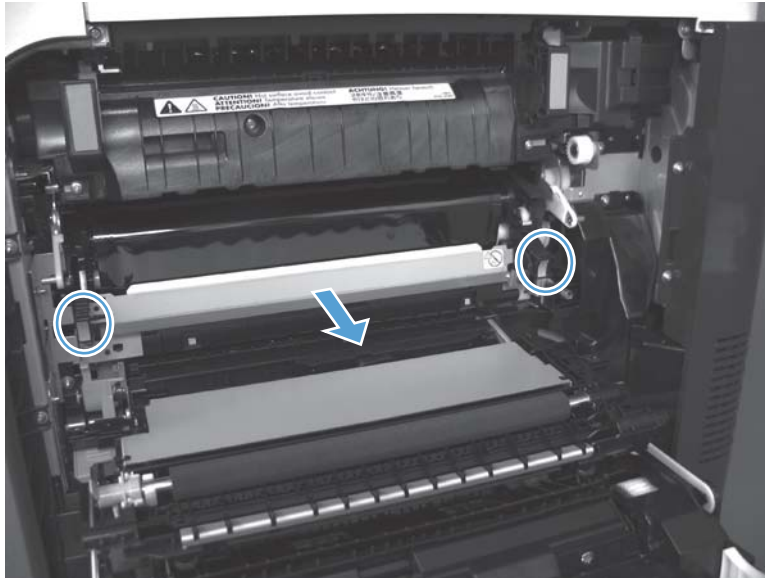

4. Grasp the large handles on the ITB and then pull the ITB straight out of the product to remove it.

CAUTION: The ITB is a sensitive component. Be careful when handling the ITB so that it is not damaged. Always place the ITB in a safe and protected location.

Figure 1-42 Remove the intermediate transfer belt (3 of 3)

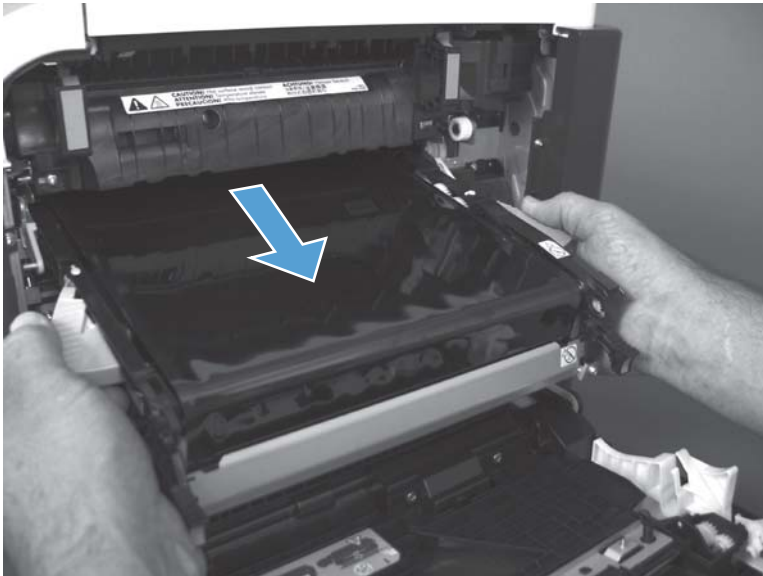

Reinstallation tip If you are installing a replacement ITB, make sure that you remove all of the packing tape (callout 1) and the protective cover sheet (callout 2).

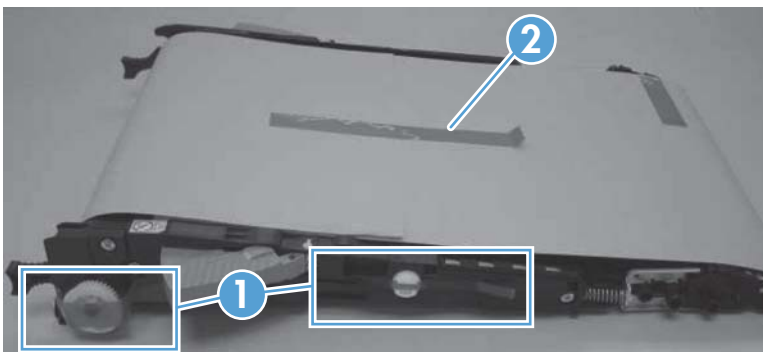

Front-door assembly

1. Open the front door.

Figure 1-43 Remove the front-door assembly (1 of 2)



2. Remove two screws (callout 1), and then remove the front-door assembly.

 **NOTE:** A small sheet-metal bracket on the left side of the door is not captive. Do not lose the bracket when you remove the screw.

Figure 1-44 Remove the front-door assembly (2 of 2)



3. If you are installing a replacement front-door assembly, install the HP name tag and the appropriate product model number tag on the assembly.

Foam reflector kit

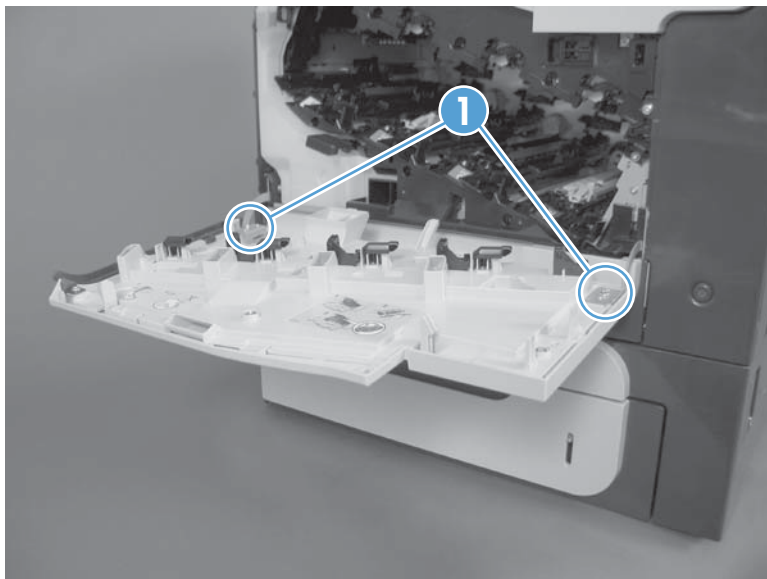
1. Open the document feeder.
2. Carefully peel the foam reflector from the document feeder.

Figure 1-45 Remove the foam reflector kit (1 of 2)

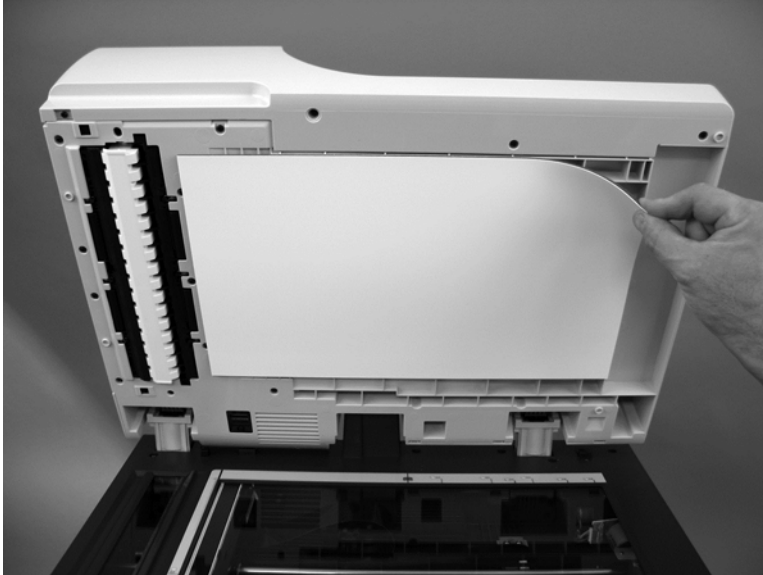

Reinstall the foam reflector

- ▲ Place the foam reflector on the scanner glass with the adhesive facing up. Make sure the corner of the foam reflector is aligned with the corner of the scanner glass (callout 1). Close the document feeder (callout 2) to attach the foam reflector. Open the document feeder and then press firmly on the foam reflector to ensure it is securely attached.

Figure 1-46 Reinstall the foam reflector

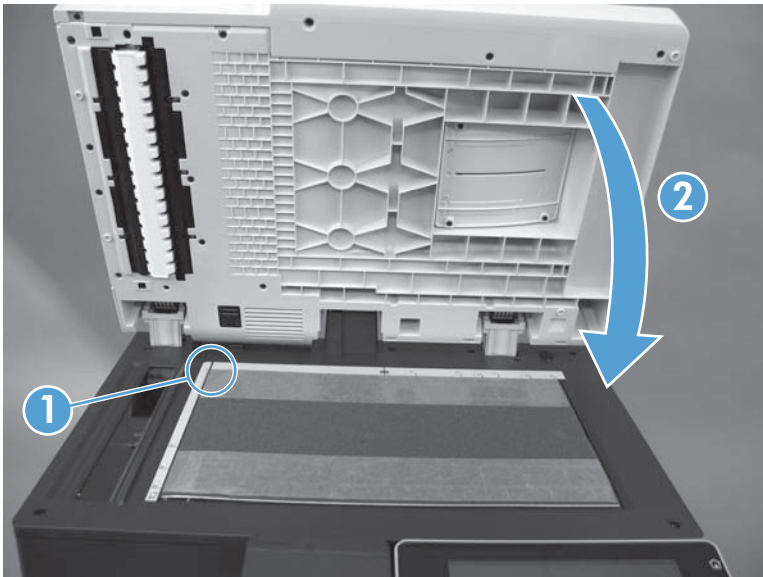

Document feeder pickup roller

⚠ CAUTION: Do not touch the surface of the roller. Skin oils deposited on the roller might cause print-quality problems.

1. Open the jam-access cover.

Figure 1-47 Remove the document feeder pickup roller (1 of 4)

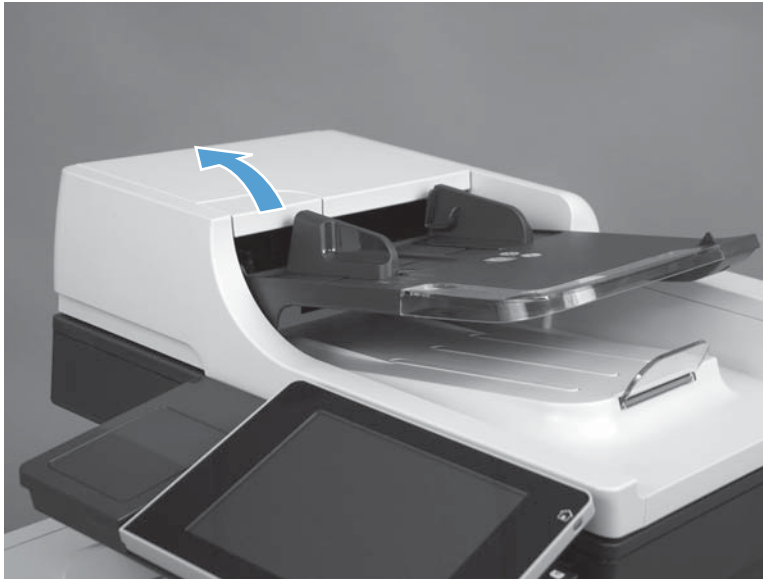

2. Open the roller-access cover.

💡 Reinstallation tip Make sure that this cover is fully closed after installing a replacement roller. Push against the upper part of the cover until it clicks into place. If the cover is not fully closed, jams and mispicks can occur.

Figure 1-48 Remove the document feeder pickup roller (2 of 4)

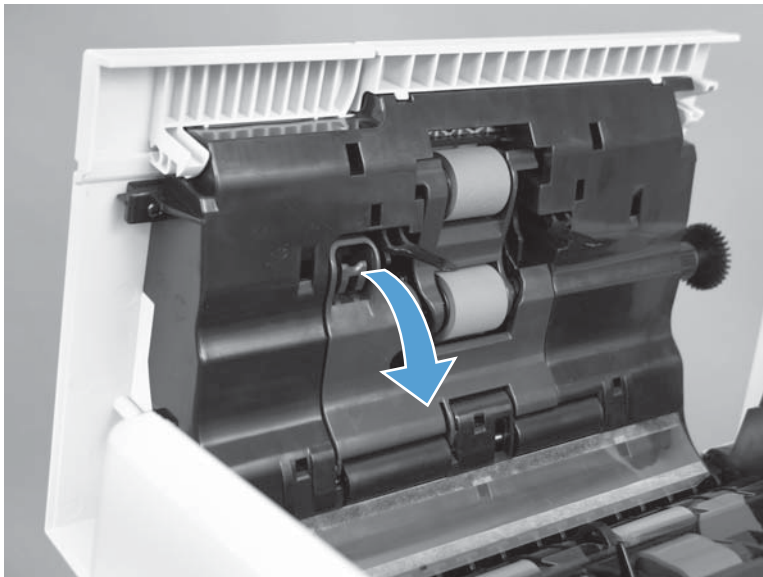

3. Lower the document feeder pickup roller.

Figure 1-49 Remove the document feeder pickup roller (3 of 4)

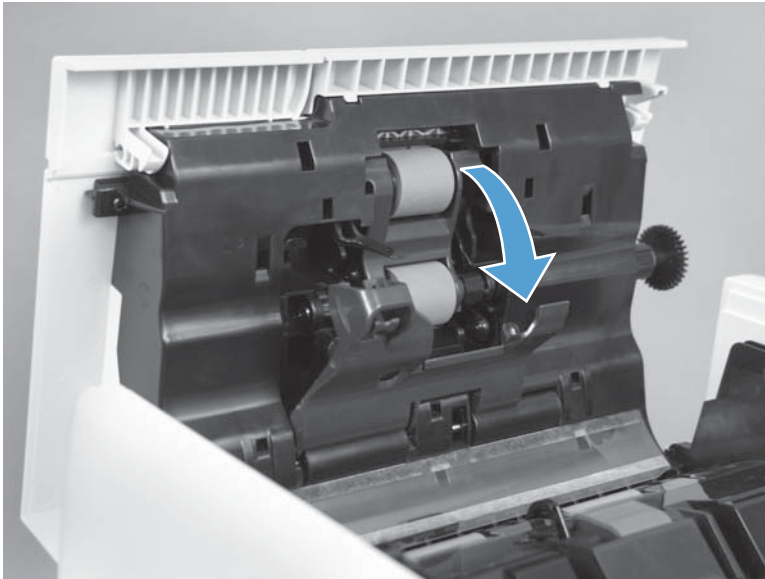

4. Slide the roller toward the front of the product to remove.

TIP: The roller assembly is keyed. When reinstalling the roller assembly, position the hex-shaped fitting on the shaft toward the rear of the product.

Figure 1-50 Remove the document feeder pickup roller (4 of 4)

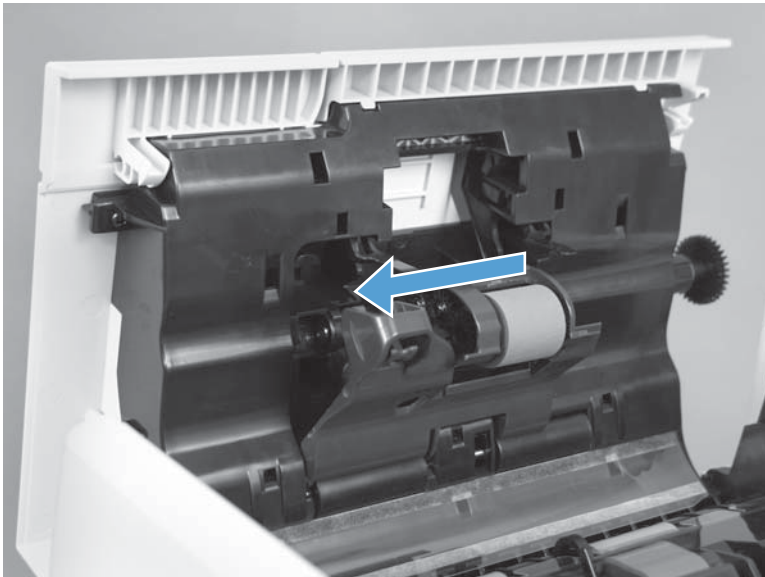

Document feeder separation pad and spring

⚠ CAUTION: Do not touch the surface of the roller. Skin oils deposited on the roller might cause print-quality problems.

1. Open the jam-access cover.

Figure 1-51 Remove the document feeder separation pad and separation pad spring (1 of 5)

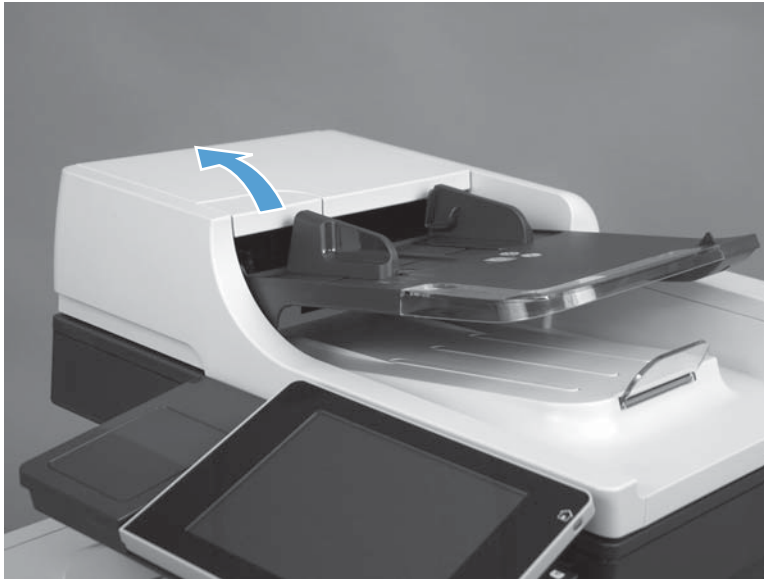

2. Lift the document feeder tray.

Figure 1-52 Remove the document feeder separation pad and separation pad spring (2 of 5)

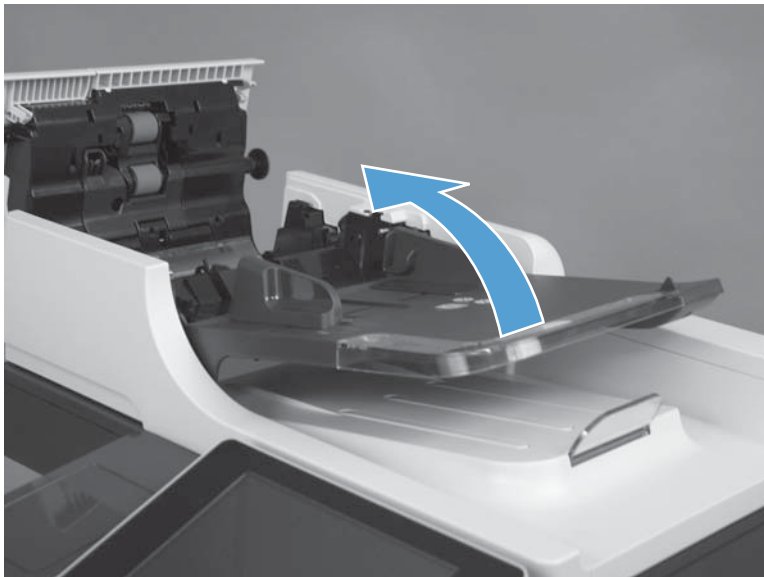

3. Push in on the latch to release the separation pad.

Figure 1-53 Remove the document feeder separation pad and separation pad spring (3 of 5)

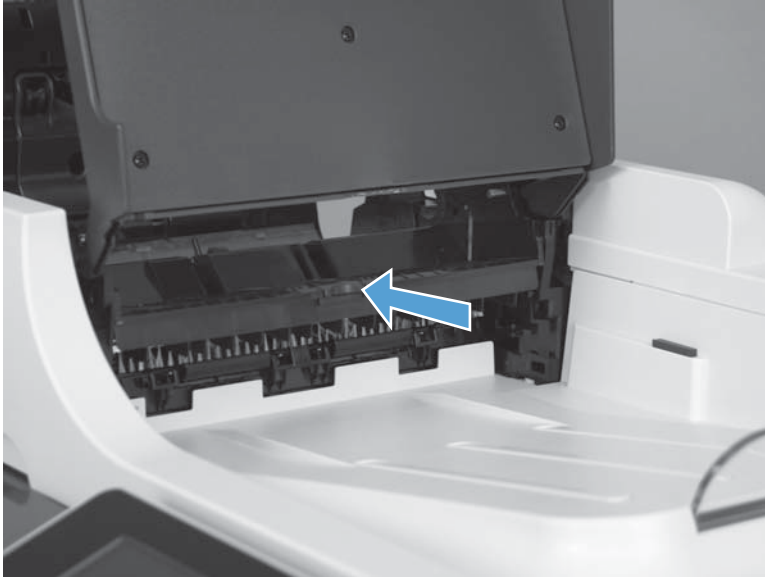

4. Lower the document tray, and then lift the separation pad.

Figure 1-54 Remove the document feeder separation pad and separation pad spring (4 of 5)

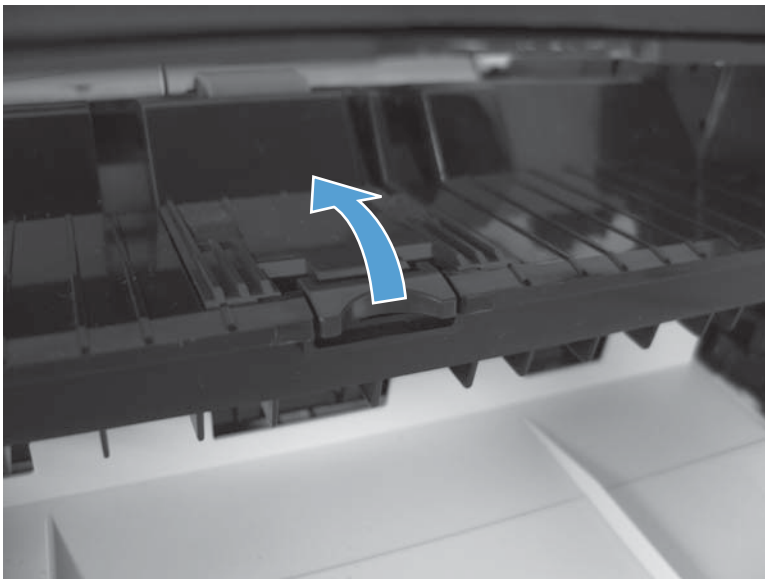

5. Remove the separation pad and spring.

Figure 1-55 Remove the document feeder separation pad and separation pad spring (5 of 5)



Reinstall the document feeder separation pad spring

- ▲ Make sure to securely reinstall the spring if it becomes dislodged.

Figure 1-56 Reinstall the document feeder separation pad spring

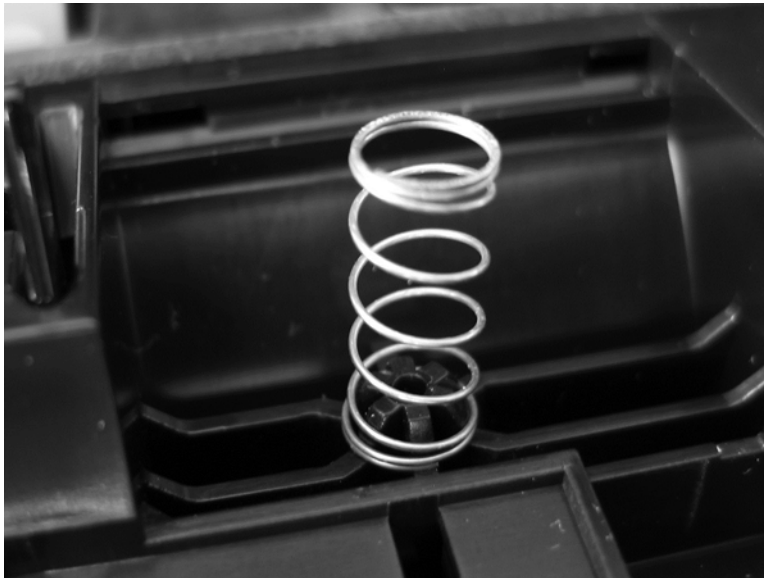

Control panel

⚠ WARNING!  ESD sensitive component.

1. Lift the control panel to an upright position.

Figure 1-57 Remove the control panel (1 of 5)

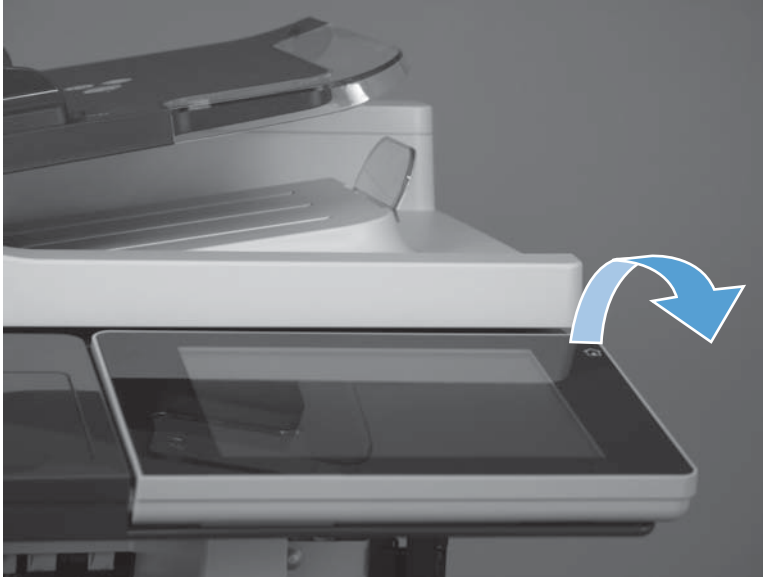

2. Lift the antistatic covers to reveal the thumbscrews.

Figure 1-58 Remove the control panel (2 of 5)

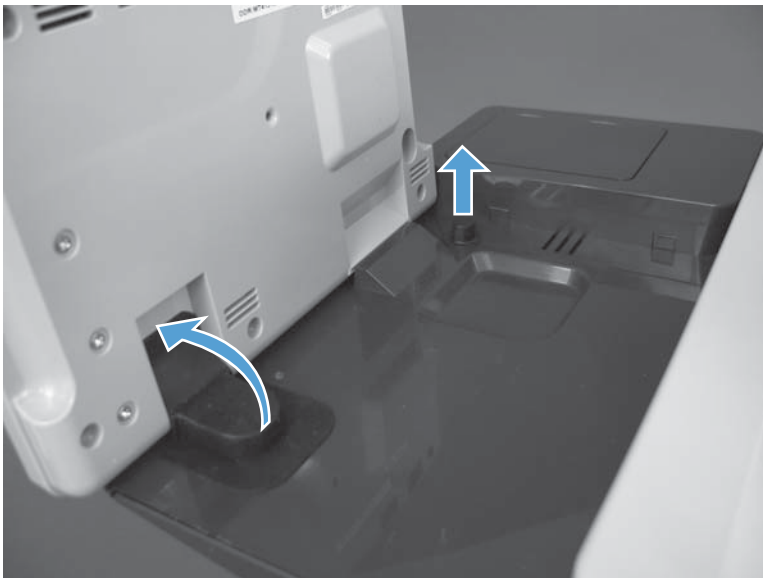

3. Remove two thumbscrews.

Figure 1-59 Remove the control panel (3 of 5)

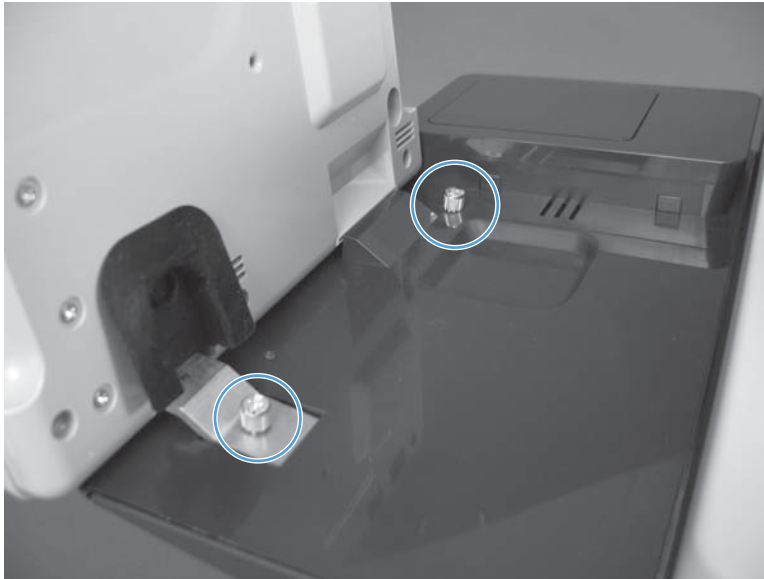

4. Slowly slide the control panel away from the product to release it. Lift the control panel to reveal the connectors.

Figure 1-60 Remove the control panel (4 of 5)

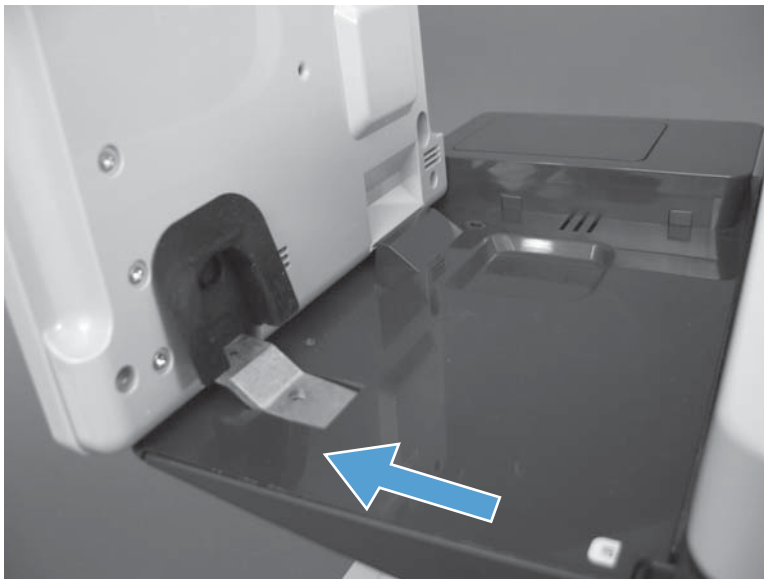

5. Disconnect two connectors and then remove the control panel.

Figure 1-61 Remove the control panel (5 of 5)

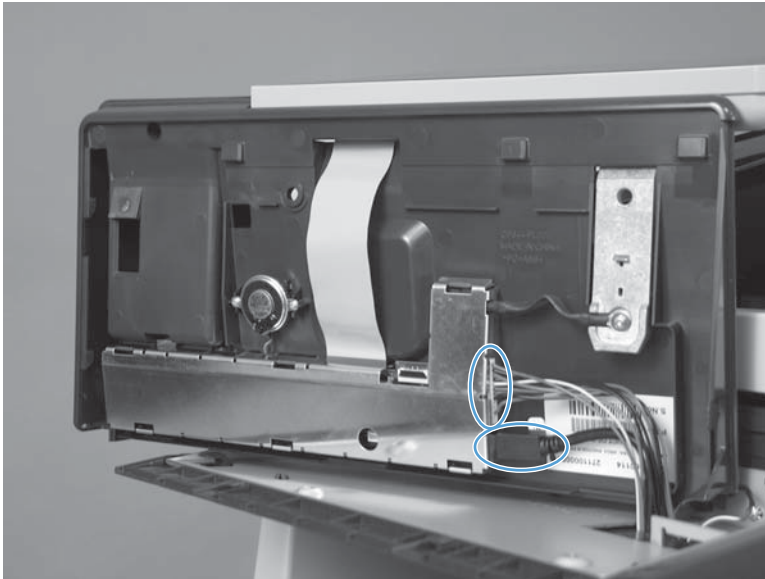

Reinstalling the control panel

- ▲ Place the control-panel on the product and reconnect the two connectors before attempting to reinstall the control panel.

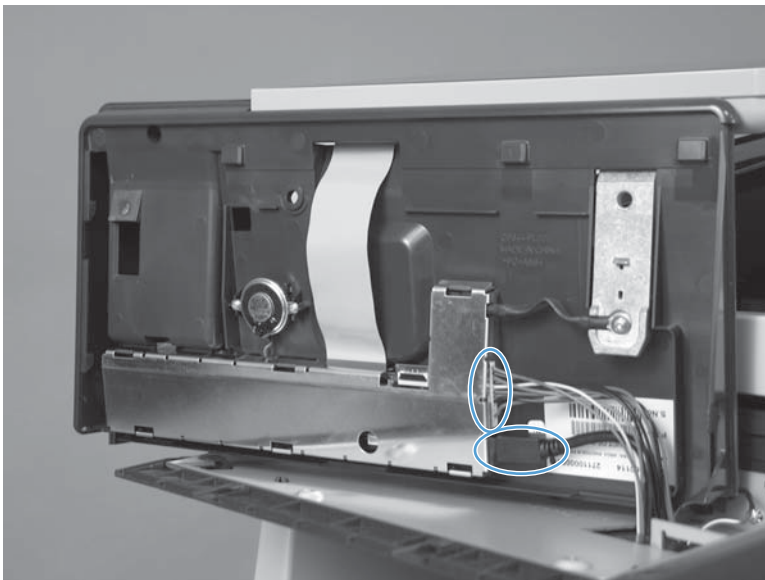

Control-panel assembly (M575c model)

 **WARNING!**  ESD sensitive component.

Important removal considerations

Review the following important considerations before removing the control panel on the M575c product.

When removing the control panel, only raise it about half way open to access the FFC connector. Doing so prevents straining the control-panel FFC (callout 1).

Figure 1-62 Raising the control panel to access the FFC connector (1 of 2)



When removing the control panel, **do not** fully raise the control panel to access the FFC connector. Doing so causes strain damage to the FFC (callout 1).

Figure 1-63 Raise the control panel to access the FFC connector (2 of 2)

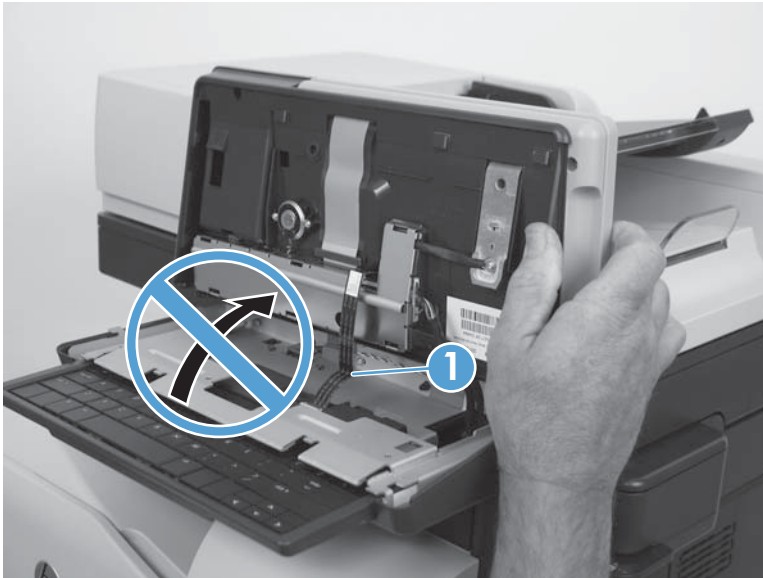

The FFC has two pre-folds about 2.54 cm (1.0 in) from either end (callout 1). If the FFC has been strained (for example stretched too tight when the control panel is removed), it might contain additional folds or creases (callout 2). Additional folds or creases can cause internal damage to the FFC when the keyboard is pulled in and out of the product.

Figure 1-64 Check the control panel FFC for damage (1 of 2)

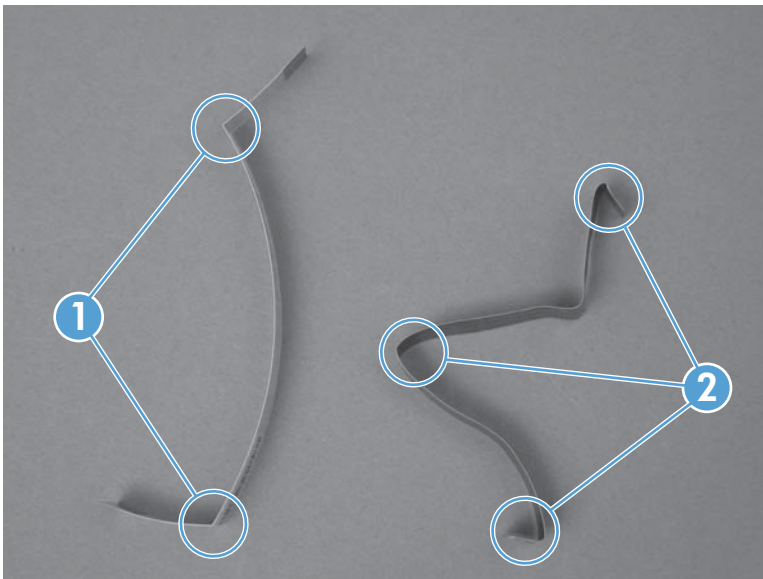

Do not bend or fold the flat flexible cable (FFC) during removal or installation. Also, do not straighten pre-folds in the FFCs.

Figure 1-65 Check the control panel FFC for damage (2 of 2)

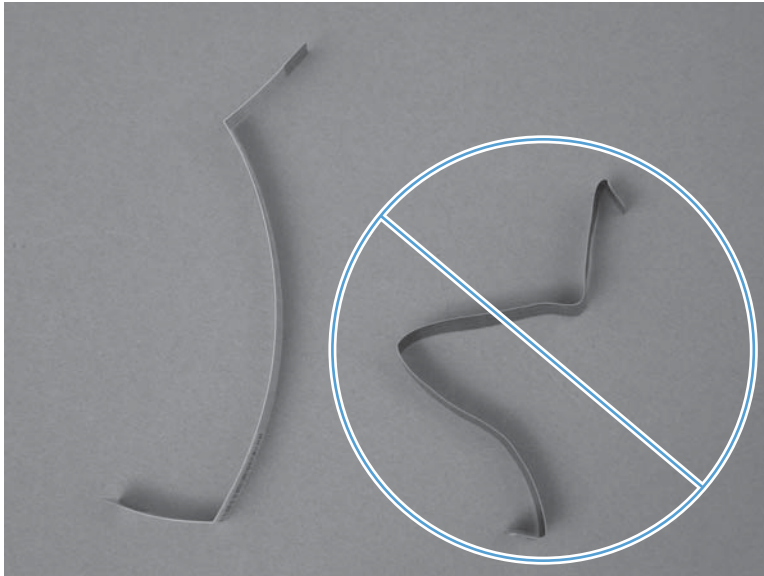

Remove the control-panel assembly

1. Pull the keyboard about half way out of the product.

Figure 1-66 Remove the control-panel assembly (1 of 13)

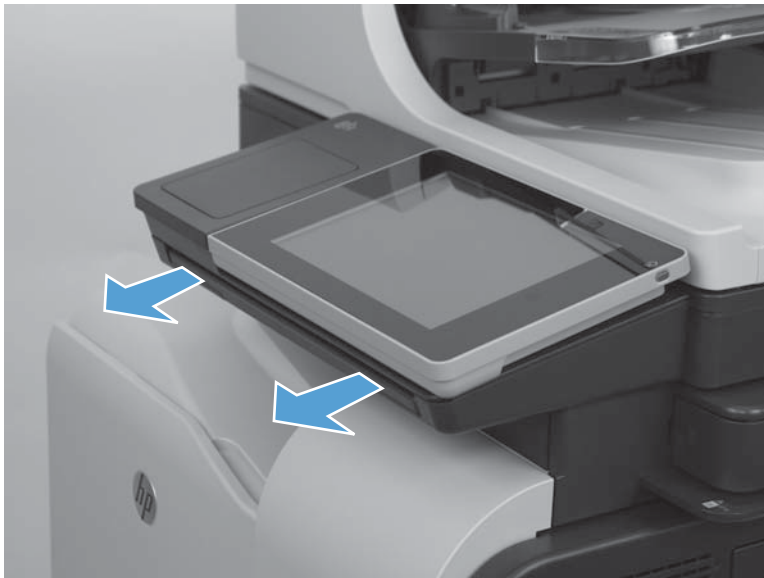

2. Align the **caps lock** key and **enter** key with the edge of the control panel.

Figure 1-67 Remove the control-panel assembly (2 of 13)



3. Lift the control-panel assembly to an upright position.

Figure 1-68 Remove the control-panel assembly (3 of 13)



4. Remove the antistatic covers to reveal the thumbscrews.

Figure 1-69 Remove the control-panel assembly (4 of 13)

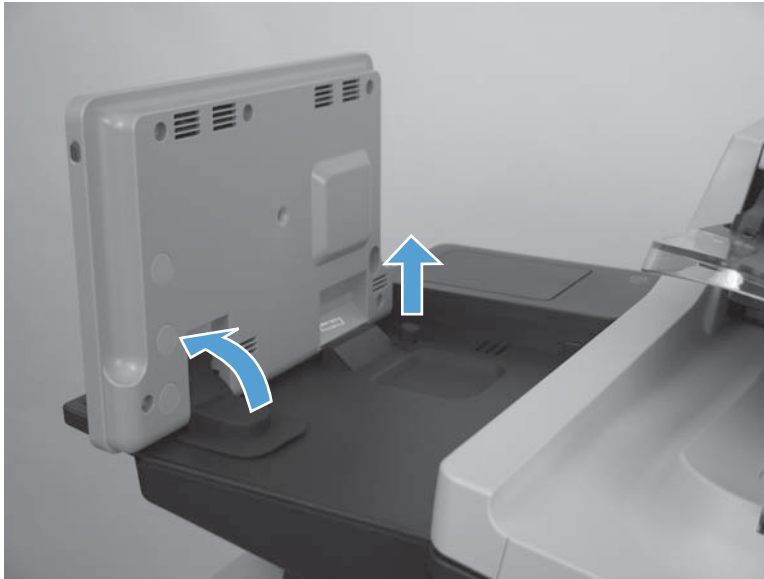

5. Remove two thumbscrews.

Figure 1-70 Remove the control-panel assembly (5 of 13)



- Carefully return the control-panel assembly to the down position.

Figure 1-71 Remove the control-panel assembly (6 of 13)

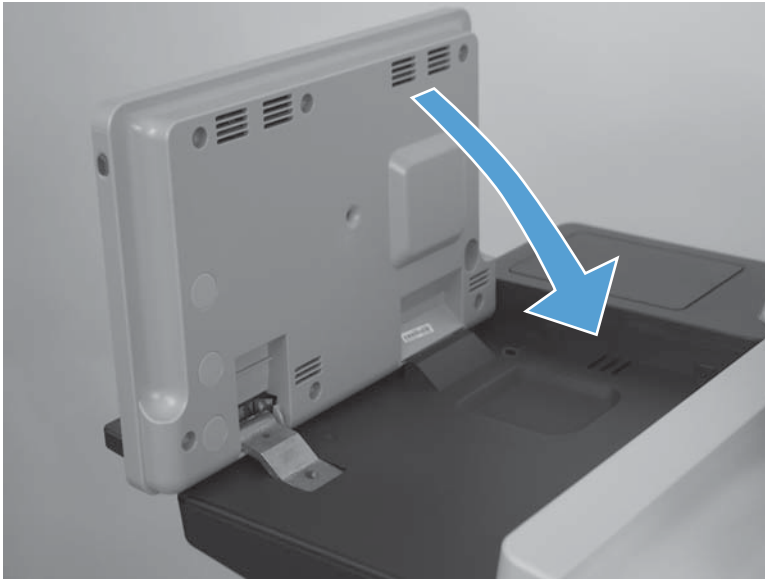

- Pull down on the control-panel assembly until it stops.

Figure 1-72 Remove the control-panel assembly (7 of 13)



8. Slightly lift up the control-panel assembly to access the FFC-keyboard connector.

⚠ CAUTION: To avoid damage to the FFC, do not fully raise the control panel assembly.

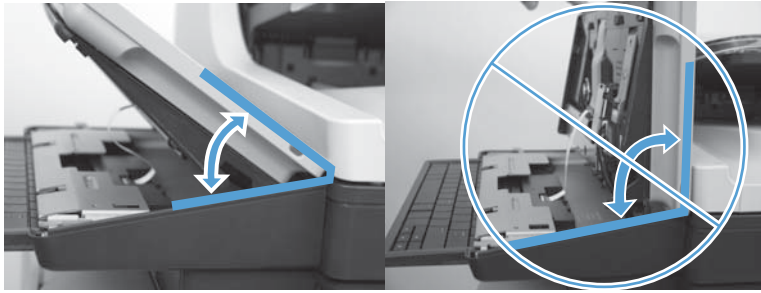
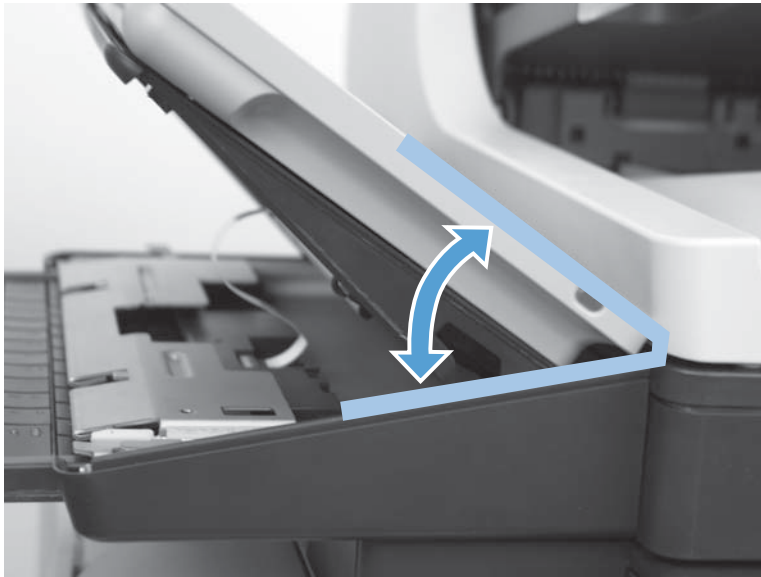

Figure 1-73 Remove the control-panel assembly (8 of 13)



9. Locate the FFC connector on the keyboard.

Figure 1-74 Remove the control-panel assembly (9 of 13)



10. Carefully lift up on the connector retainer to release the FFC.

Figure 1-75 Remove the control-panel assembly (10 of 13)

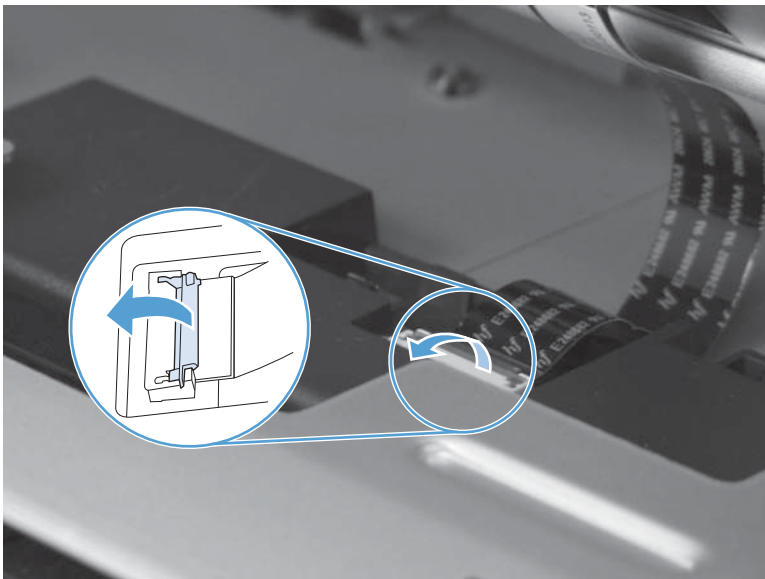

11. Remove the FFC from the connector on the keyboard.

Figure 1-76 Remove the control-panel assembly (11 of 13)

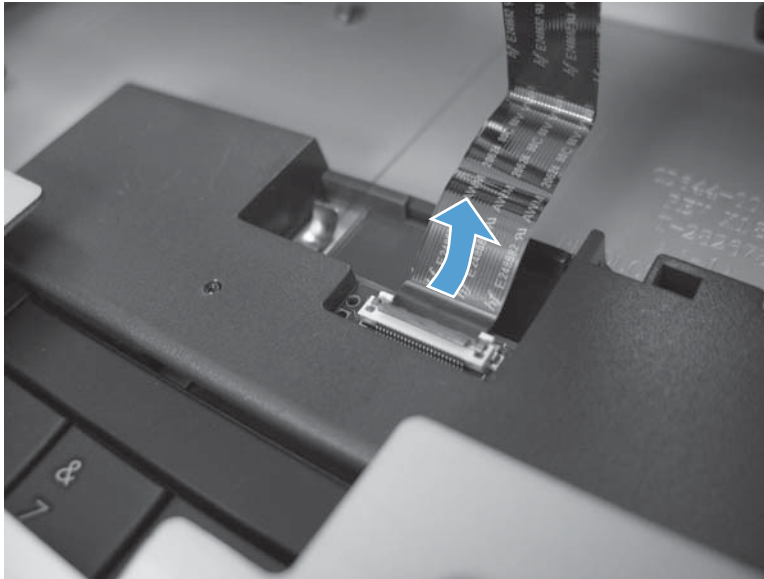

12. With the FFC disconnected from the keyboard, lift up on the control panel to access the remaining connectors. Disconnect the USB and wire harness connectors (callout 1).

Figure 1-77 Remove the control-panel assembly (12 of 13)

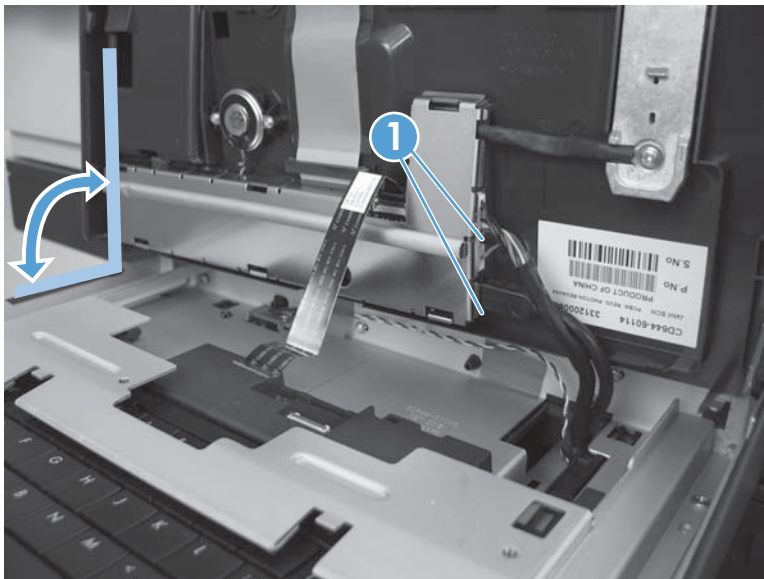

13. Remove the control-panel assembly.

Figure 1-78 Remove the control-panel assembly (13 of 13)



Reinstall the control-panel assembly

1. Position the control panel on the product. Connect the USB and wire harness connectors (callout 1).

Figure 1-79 Reinstall the control-panel assembly (1 of 13)

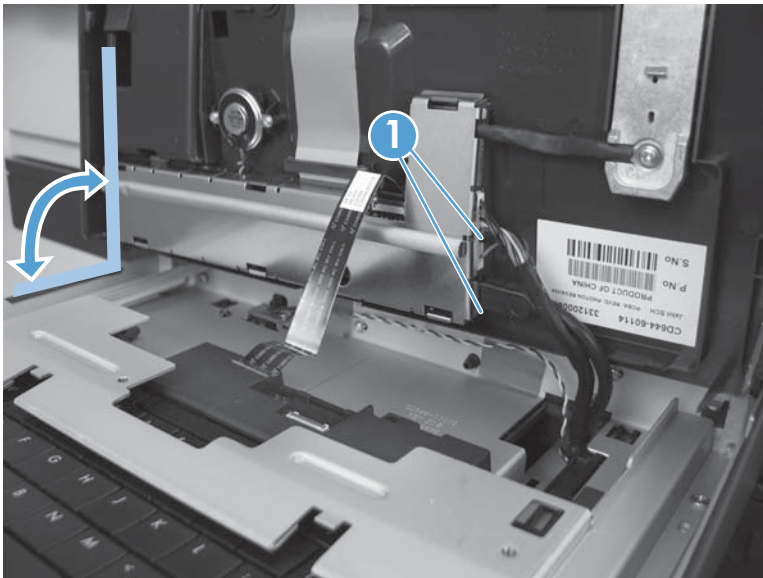

2. After connecting the USB and wire harness connectors, position the control-panel about half way open to connect the FFC connector.

Figure 1-80 Reinstall the control-panel assembly (2 of 13)



3. Insert the FFC in the keyboard connector.

Figure 1-81 Reinstall the control-panel assembly (3 of 13)



4. Use your finger to carefully close the connector retainer to lock the FFC in place.

CAUTION: Be careful. The connector retainer can be dislodged from the connector body. Do not dislodge the retainer when closing it.

Figure 1-82 Reinstall the control-panel assembly (4 of 13)



5. Slightly pull on the FFC to verify that it is securely fastened in the connector.

CAUTION: Be careful. Do not use your full force to pull on the FFC. A slight pull on the FFC is sufficient to verify that it is securely fastened.

Figure 1-83 Reinstall the control-panel assembly (5 of 13)

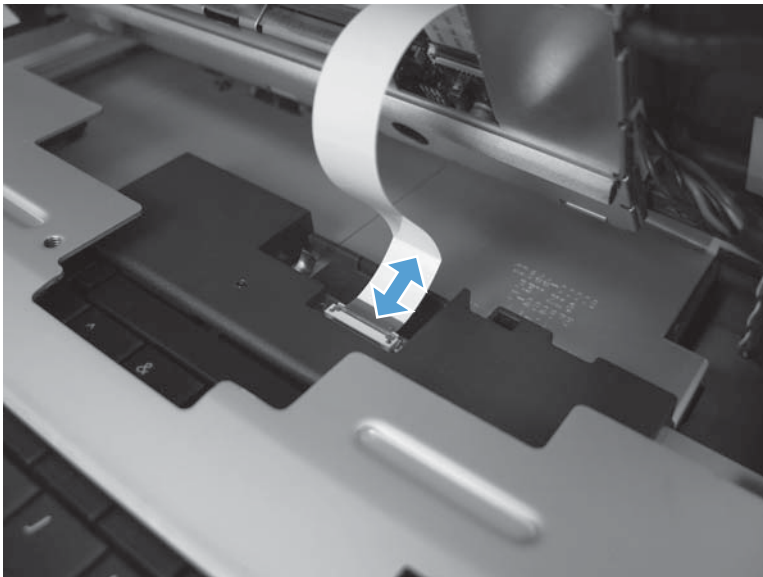

6. When the control-panel assembly is reinstalled on the product, make sure that the mounting hooks on the right side of the assembly engage with the slot and tab on the chassis.

Figure 1-84 Reinstall the control-panel assembly (6 of 13)

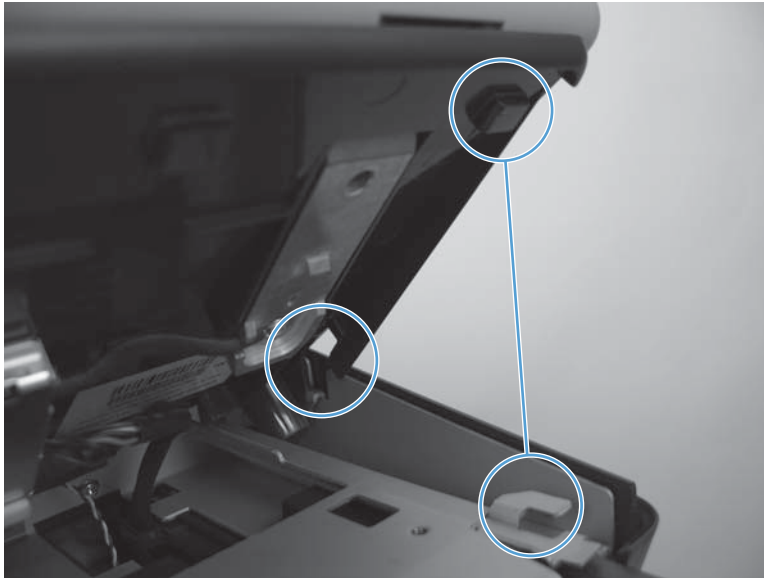

7. When the control-panel assembly is reinstalled on the product, make sure that the mounting slots on the left side of the assembly engage with the hooks on the chassis.

Figure 1-85 Reinstall the control-panel assembly (7 of 13)

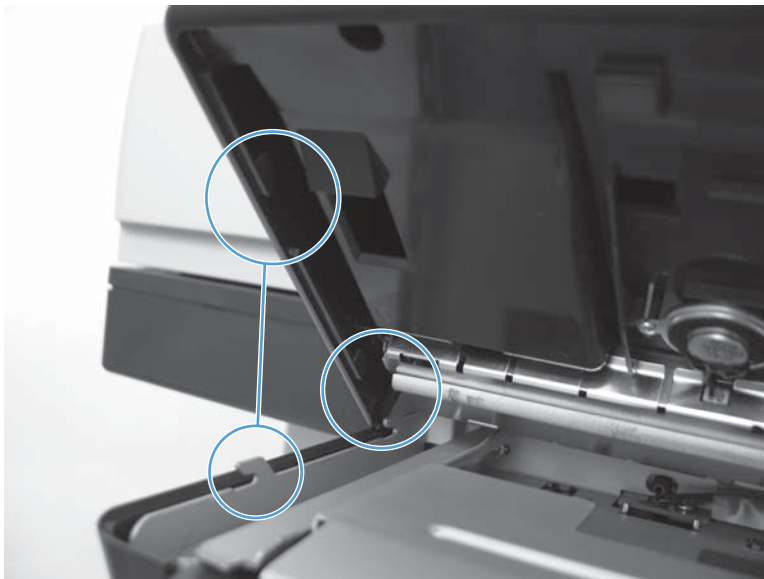

8. Reinstall the control-panel assembly on the product, and then push it up to engage the assembly with the chassis.

Figure 1-86 Reinstall the control-panel assembly (8 of 13)



9. Carefully place the control-panel assembly in the raised position.

Figure 1-87 Reinstall the control-panel assembly (9 of 13)



10. Install two thumbscrews.

Figure 1-88 Reinstall the control-panel assembly (10 of 13)

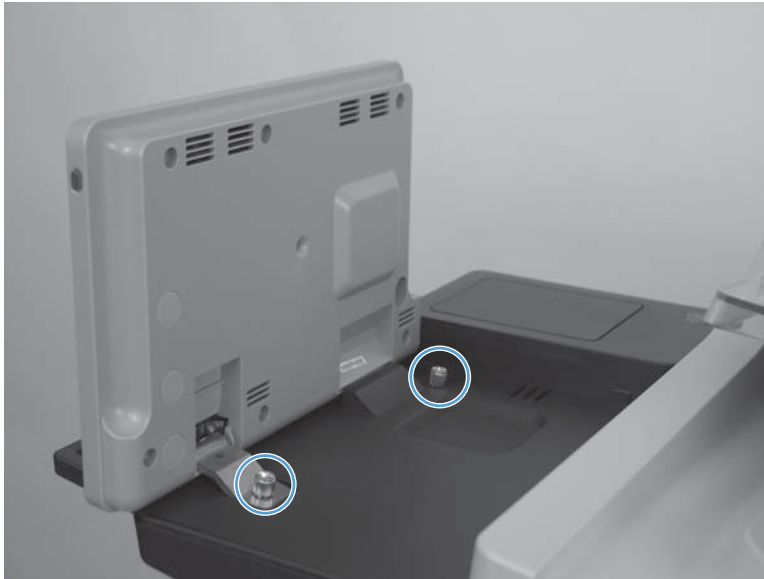

11. Install the antistatic covers.

Figure 1-89 Reinstall the control-panel assembly (11 of 13)

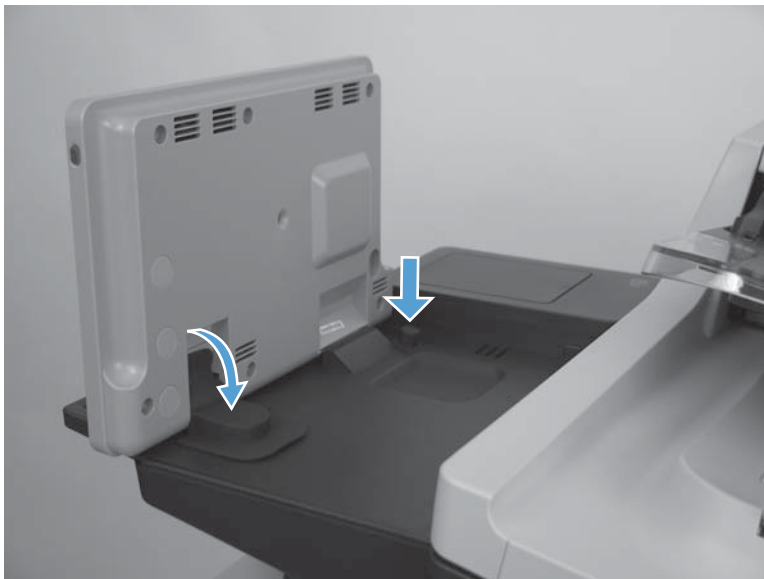

12. Lower the control-panel assembly.

Figure 1-90 Reinstall the control-panel assembly (12 of 13)



13. Slide the keyboard back into the product.

 **TIP:** Slide the keyboard in and out of the product to verify that the FFC is not binding under the control-panel assembly.

Figure 1-91 Remove the control-panel assembly (13 of 13)



Control-panel assembly to keyboard FFC (M575c model)

Before proceeding, remove the following assemblies

- Control-panel assembly. See [Control-panel assembly \(M575c model\) on page 47](#).

Important considerations

The FFC has two prefolds about 2.54 cm (1.0 in) from either end (callout 1). If the FFC has been strained (for example stretched too tight when the control panel is removed), it might contain additional folds or creases (callout 2).

Additional folds or creases can cause internal damage to the FFC when the keyboard is pulled in and out of the product.

Replace the FFC if it is damaged.

Figure 1-92 Control-panel assembly to keyboard FFC

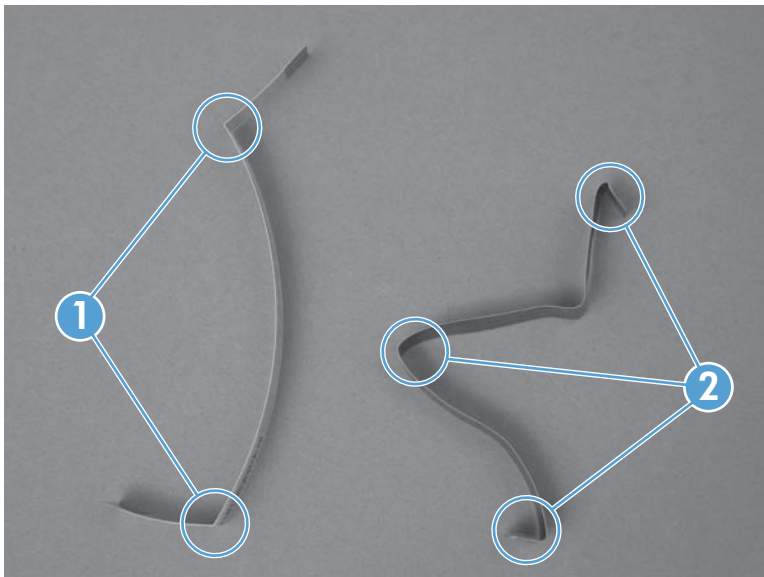

Remove the control-panel assembly to keyboard FFC

1. Turn the control-panel assembly over, and then locate the FFC connector.

Figure 1-93 Remove the control-panel assembly to keyboard FFC (1 of 3)

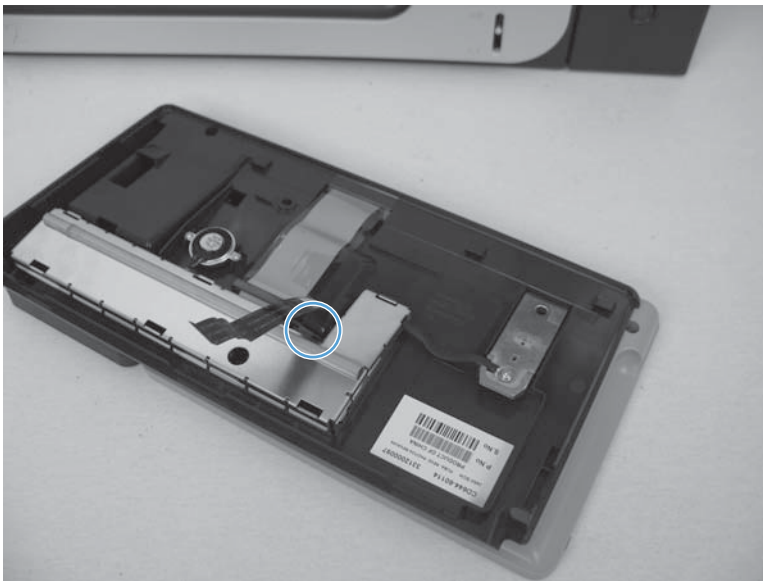

2. Hold the FFC out of the way, and then carefully lift up on the connector retainer to release the FFC.

Figure 1-94 Remove the control-panel assembly to keyboard FFC (2 of 3)

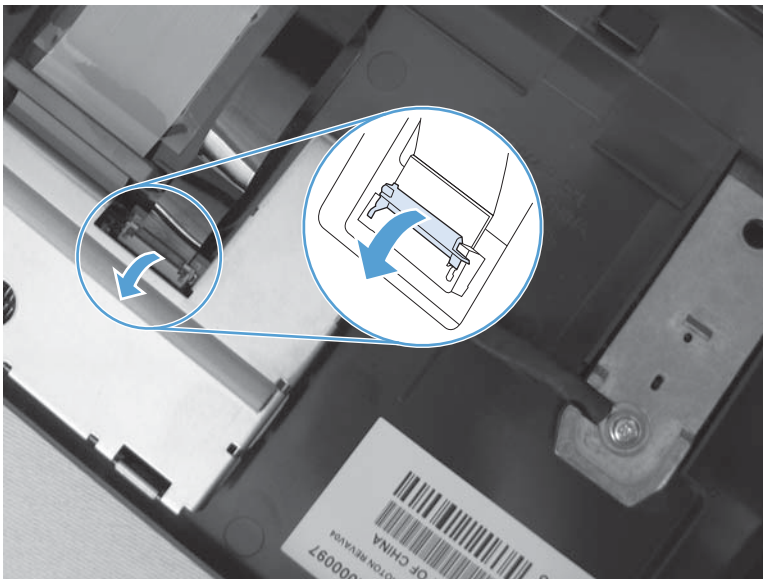

3. Remove the FFC from the connector on the control-panel assembly.

Figure 1-95 Remove the control-panel assembly to keyboard FFC (3 of 3)

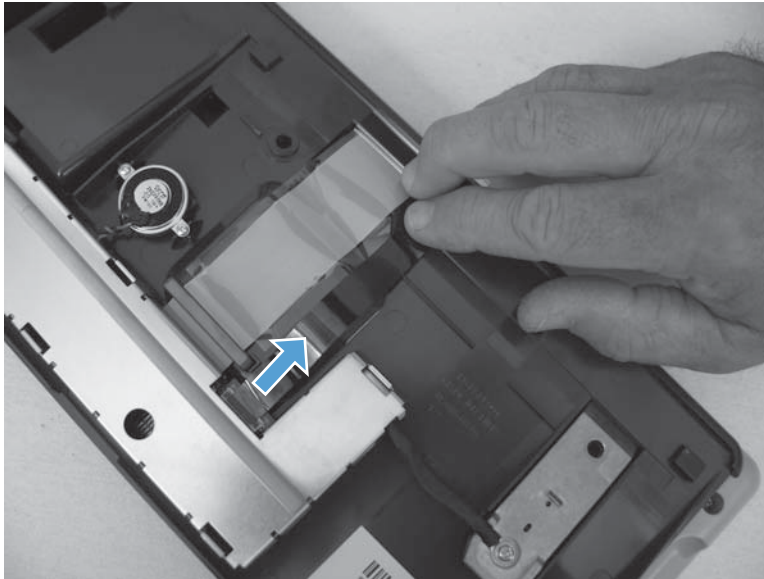

Reinstall the control-panel assembly to keyboard FFC

1. Verify that the contact side of the replacement FFC (callout 1) is placed against the contacts in the connector (callout 2) when the FFC is installed.

Figure 1-96 Reinstall the control-panel assembly to keyboard FFC (1 of 4)

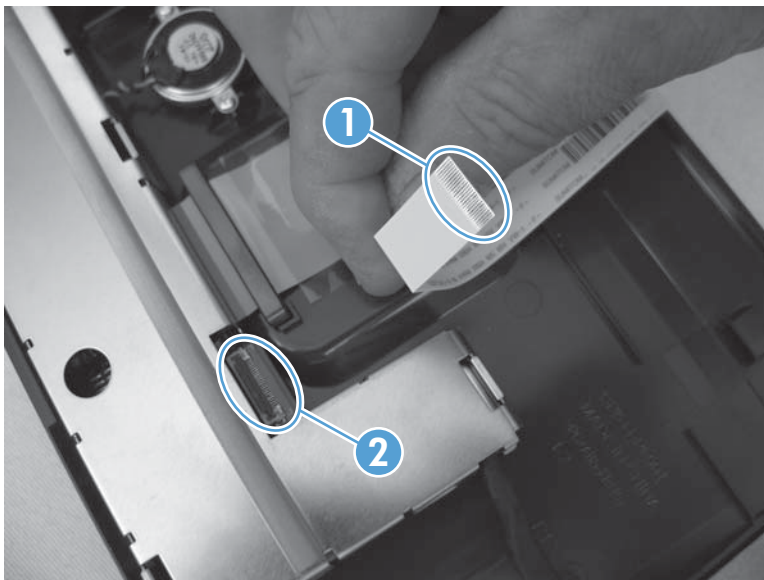

2. Insert the FFC in the control-panel connector.

Figure 1-97 Reinstall the control-panel assembly to keyboard FFC (2 of 4)



3. Use your finger to carefully close the connector retainer to lock the FFC in place.

⚠ CAUTION: Be careful. The connector retainer can be dislodged from the connector body. Do not dislodge the retainer when closing it.

Figure 1-98 Reinstall the control-panel assembly to keyboard FFC (3 of 4)



4. Slightly pull on the FFC to verify that it is securely fastened in the connector.

⚠ CAUTION: Be careful. Do not use your full force to pull on the FFC. A slight pull on the FFC is sufficient to verify that it is securely fastened.

Figure 1-99 Reinstall the control-panel assembly to keyboard FFC (4 of 4)



Keyboard assembly (M575c model)

Before proceeding, remove the following assemblies

- Control-panel assembly. See [Control-panel assembly \(M575c model\) on page 47](#).

Remove the keyboard assembly

1. Remove four screws.

Figure 1-100 Remove the keyboard assembly (1 of 7)

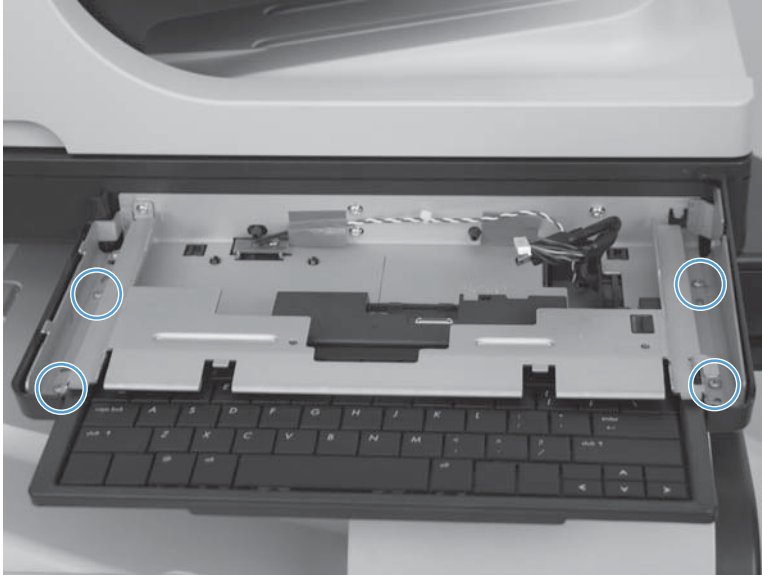

2. Slightly lift up the sheet-metal bracket, and then slide the keyboard away from the product to remove it.

⚠ CAUTION: The sheet metal bracket is still attached to the product by one screw. Avoid damaging or bending the bracket by only lifting it up enough to release the keyboard.

Figure 1-101 Remove the keyboard assembly (2 of 7)

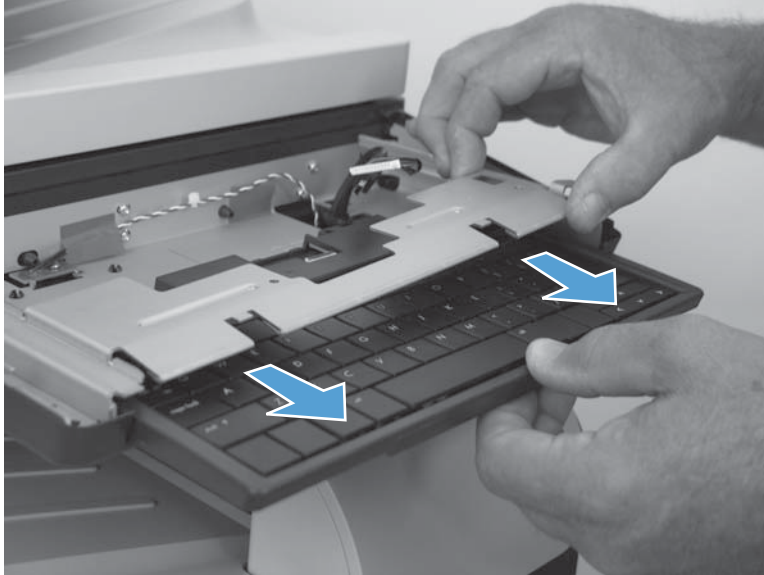

3. Turn the assembly over, and then remove the access door.

Figure 1-102 Remove the keyboard assembly (3 of 7)

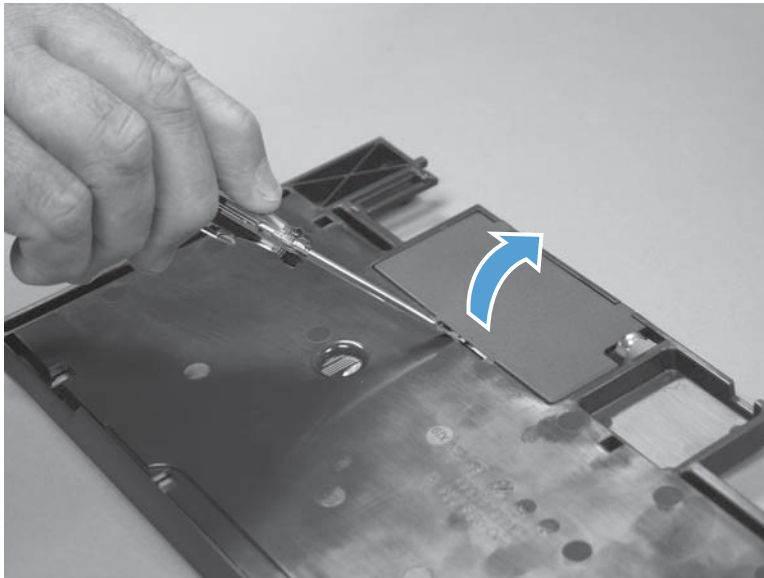

4. Release the retainer lock (callout 1), and then disconnect one FFC.

Figure 1-103 Remove the keyboard assembly (4 of 7)

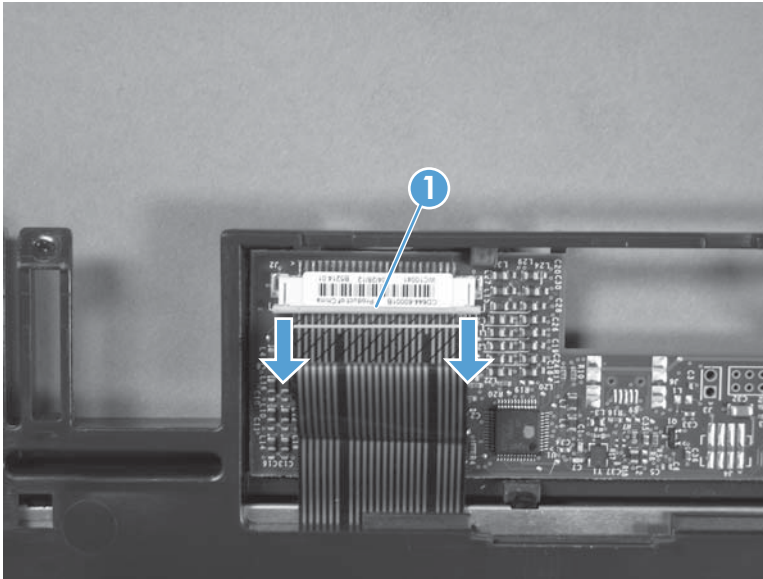

5. Turn the assembly over, and then push the four retainer clips (callout 1) toward the keyboard to release them.

Figure 1-104 Remove the keyboard assembly (5 of 7)

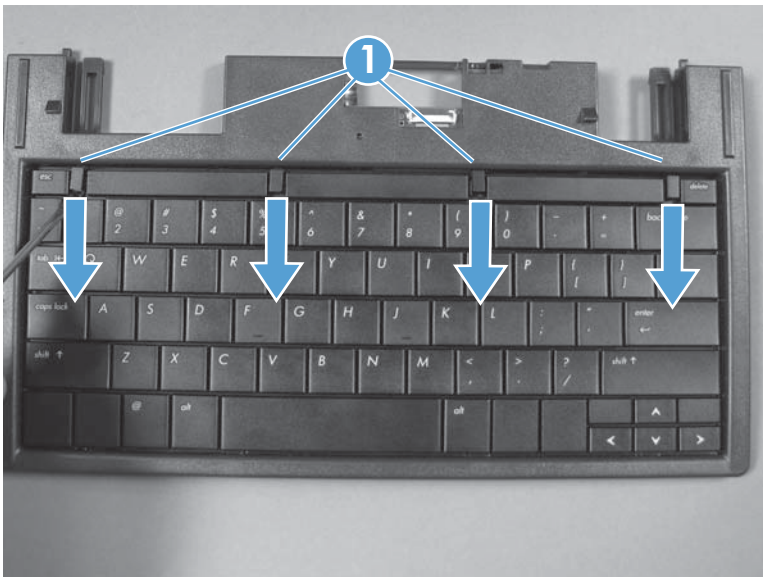

6. Rotate the top of the keyboard away from the tray, and then slide it up to release it.

 **NOTE:** The keyboard is still attached to the tray. Do not attempt to completely remove it.

 **TIP:** Push your finger through the hole provided in the back side of the tray to lift the keyboard.

Figure 1-105 Remove the keyboard assembly (6 of 7)

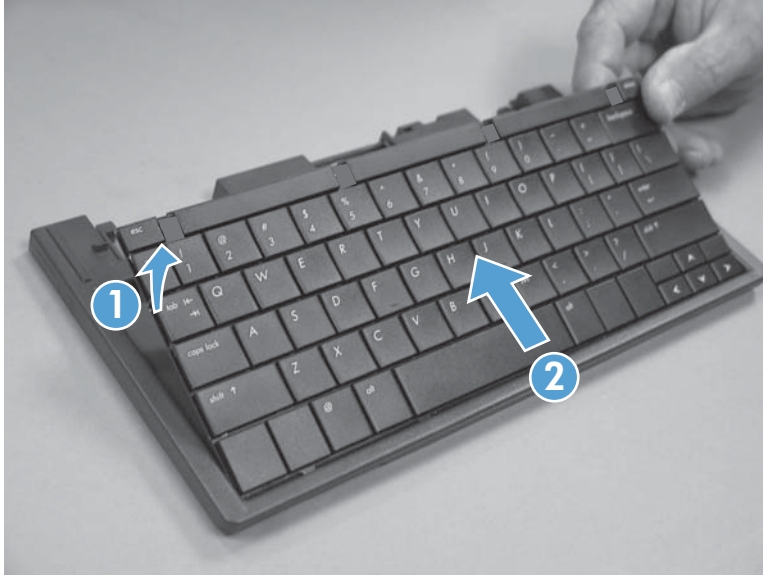

7. Thread the FFC through the hole in the tray, and then remove the keyboard.

Figure 1-106 Remove the keyboard assembly (7 of 7)

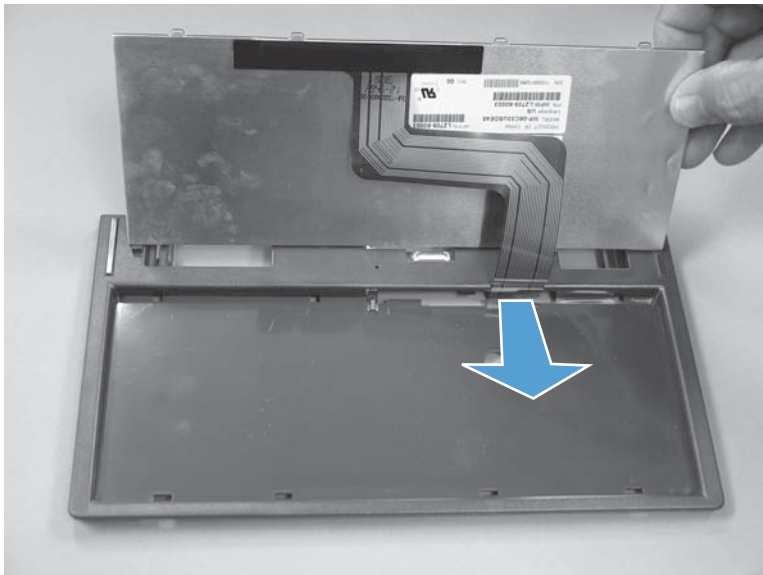

Keyboard overlay (M575c model)

To change the language set on the full-function QWERTY keyboard, install a keyboard overlay.

Install a keyboard overlay

1. Turn the overlay over to expose the paper backing.

Figure 1-107 Install a keyboard overlay (1 of 6)

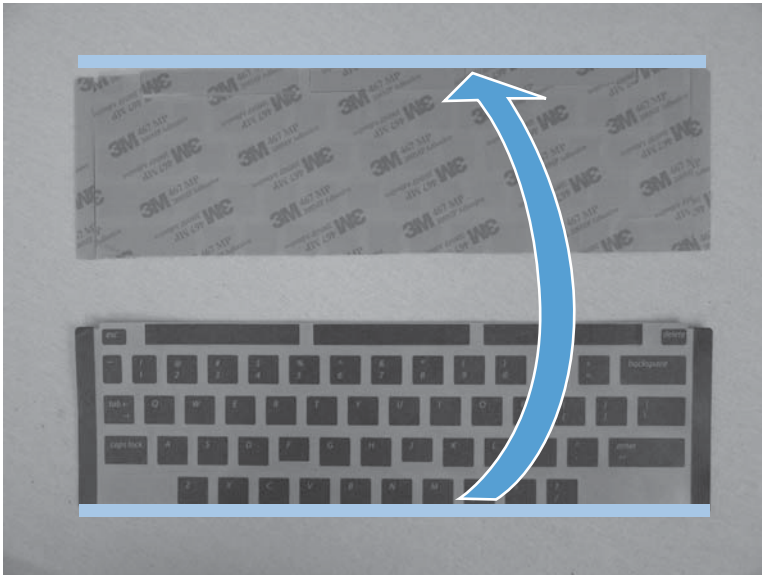

2. Carefully peel the paper backing off of the overlay.

CAUTION: Do not touch the exposed adhesive-backed button overlays.

NOTE: Keep the paper backing close to the overlay as you peel it off to avoid accidentally removing any of the adhesive-backed button overlays.

Figure 1-108 Install a keyboard overlay (2 of 6)

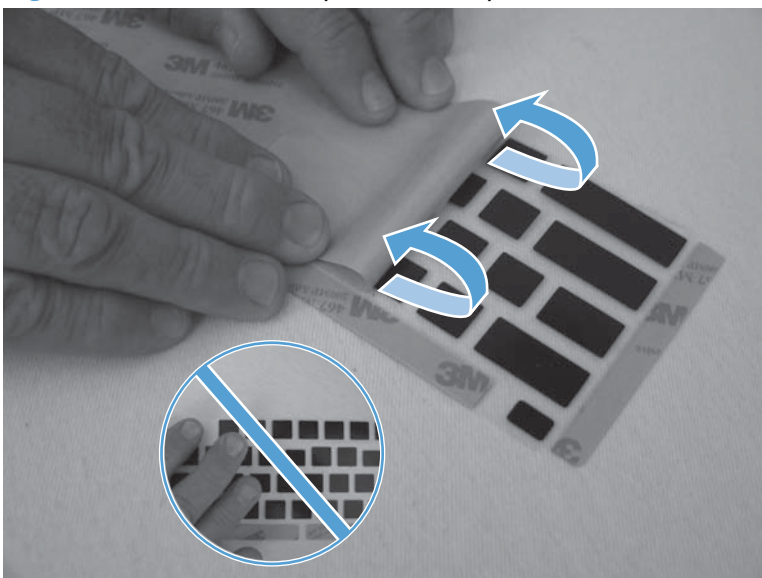

3. Position the top edge of the overlay along the top edge of the keyboard.

Figure 1-109 Install a keyboard overlay (3 of 6)

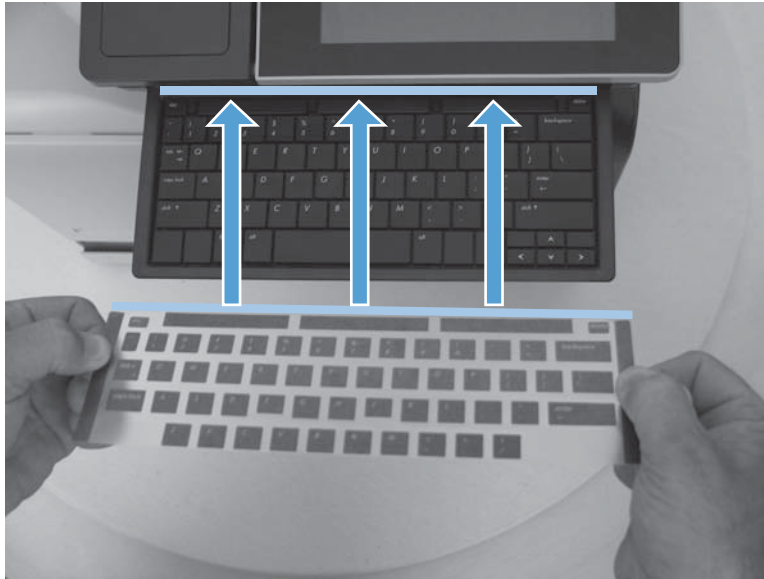

4. Align the overlay on the keyboard. When the overlay is correctly aligned, lay it flat on the keyboard.

 **TIP:** The overlay is correctly aligned when you can see the four keyboard lock tabs through the clear plastic top sheet.

Figure 1-110 Install a keyboard overlay (4 of 6)



5. Support the keyboard tray (callout 1), push down on the top sheet (callout 2), and then firmly slide your hand (callout 3) along the top sheet to adhere the adhesive-backed button overlays to the keyboard buttons.

CAUTION: To avoid damage to the keyboard tray, you must support the tray before pushing down on the top sheet.

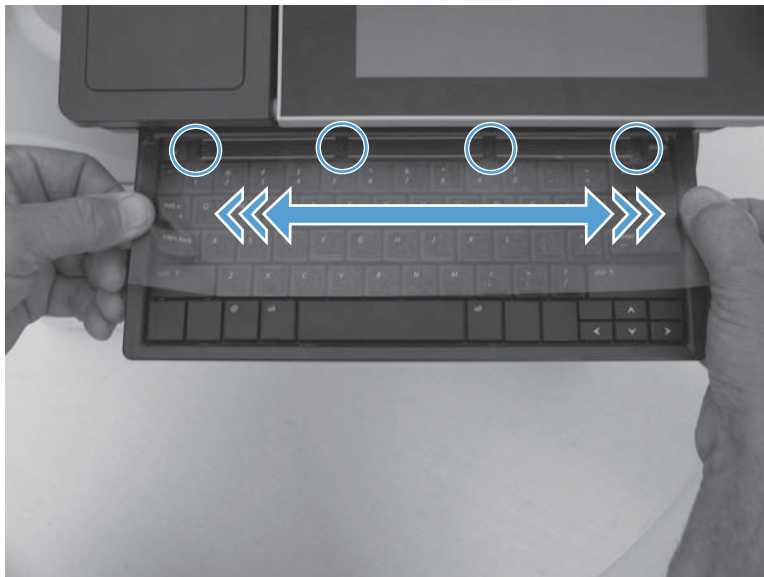
Figure 1-111 Install a keyboard overlay (5 of 6)

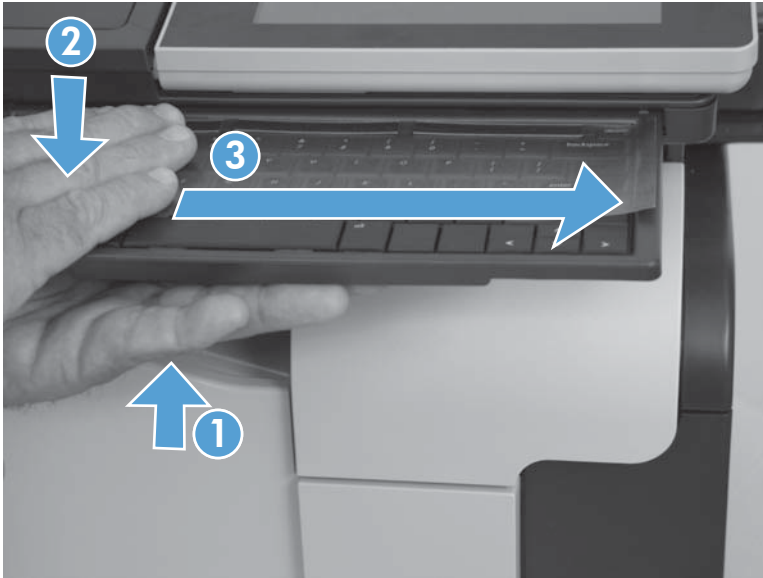

- Carefully peel the top sheet off of the keyboard.

 **NOTE:** Keep the top sheet close to the keyboard as you peel it off to avoid accidentally removing any of the adhesive-backed button overlays.

 **TIP:** If any of the adhesive-backed button overlays fail to adhere to the keyboard, stop peeling back the top sheet. Support the keyboard tray, and then firmly slide your hand along the top sheet again to adhere the button overlays to the keyboard.

Figure 1-112 Install a keyboard overlay (6 of 6)



Back-side background selector assembly (M575c model)

CAUTION: Do not touch the surface of the rollers. Skin oils deposited on the rollers might cause print-quality problems.

1. Open the jam-access cover, and then raise the input tray.

Figure 1-113 Remove the back-side background selector assembly (1 of 3)

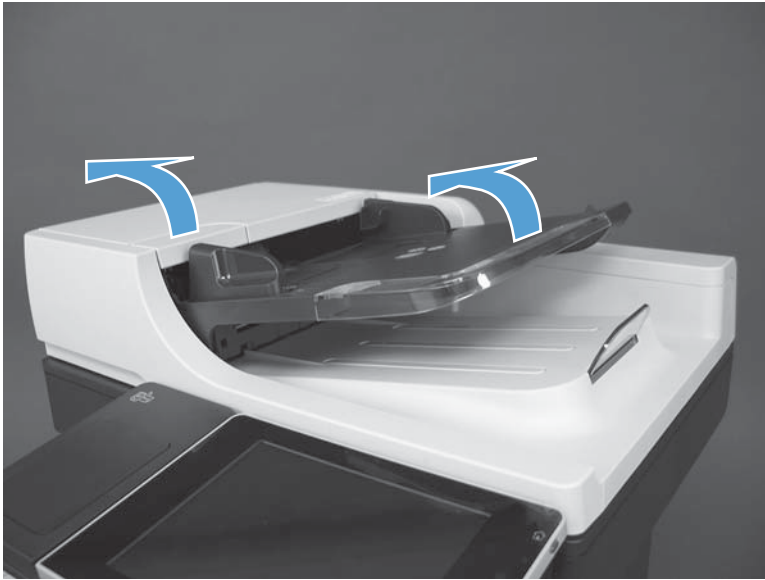

2. Release two retainers on the assembly.

Figure 1-114 Remove the back-side background selector assembly (2 of 3)

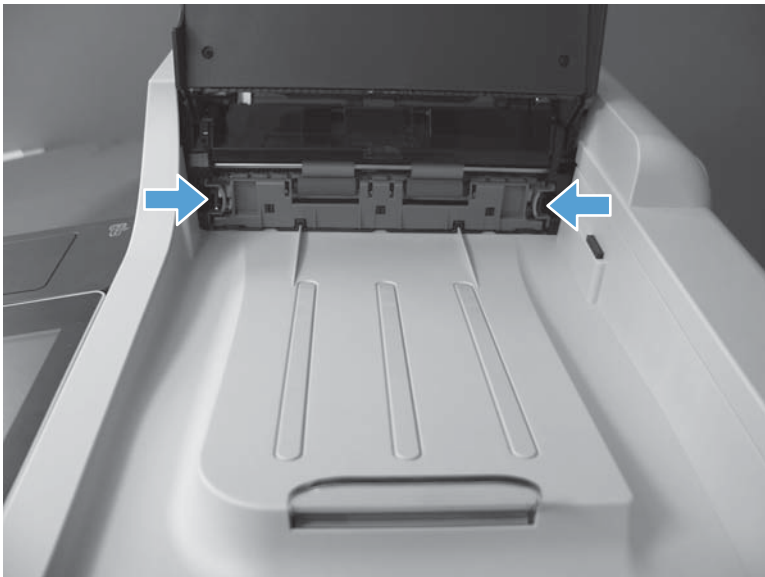

- Carefully slide the assembly away from the product to remove it.

 **Reinstallation tip** Make sure the assembly is fully seated when it is reinstalled.

The white portion of the back-side background selector can get dirty and might need to be wiped down before reinstalling it.

Figure 1-115 Remove the back-side background selector assembly (3 of 3)



Right door (optional paper feeder)

1. Open the right door.

Figure 1-116 Remove the right door; optional paper feeder (1 of 3)

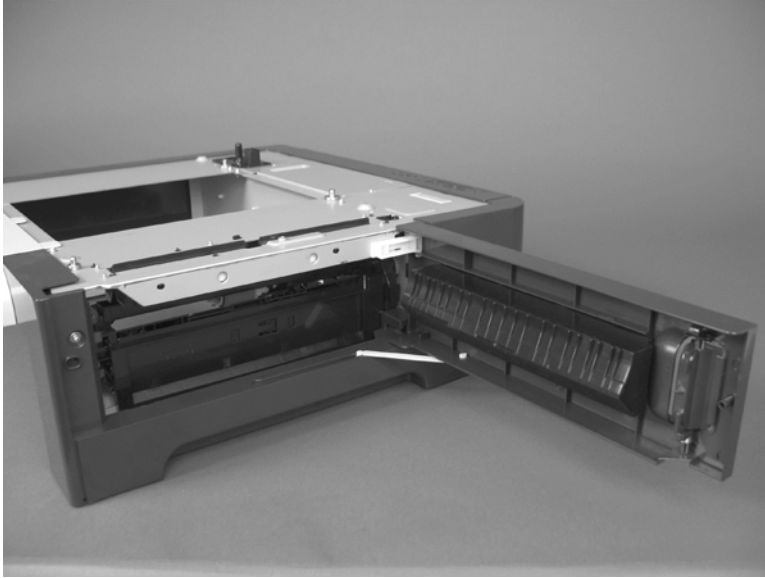

2. Release one tab (callout 1), and then slide the stopper toward the right side of the product to remove it.

Figure 1-117 Remove the right door; optional paper feeder (2 of 3)

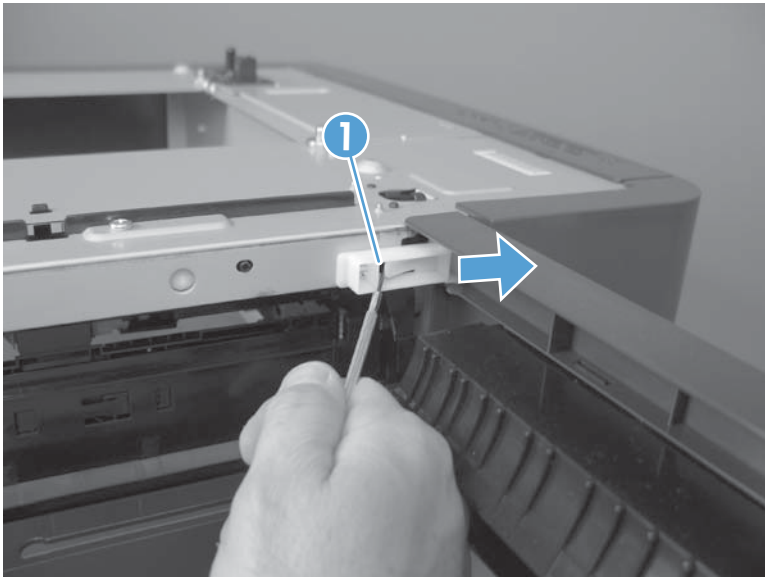

3. Support the door, and then release the door-retainer arm at the bottom of the door. Raise the door to release the lower hinge pin, and then remove the door.

Figure 1-118 Remove the right door; optional paper feeder (3 of 3)

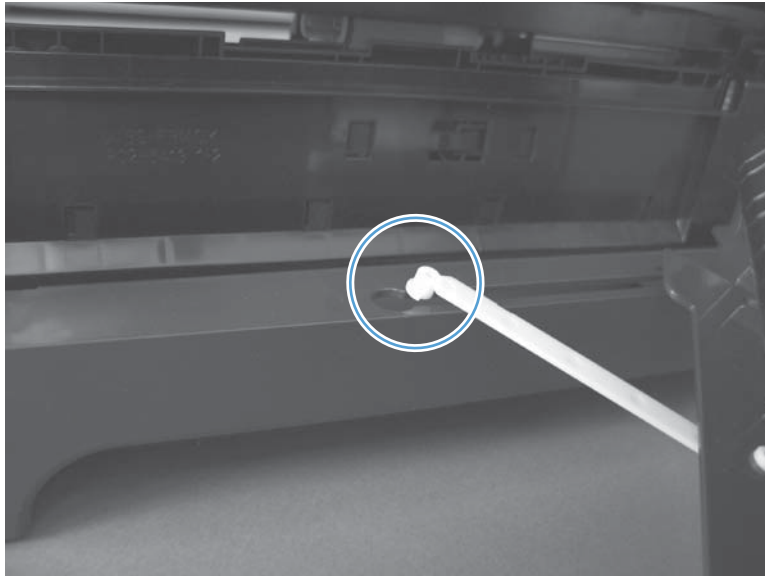

External panels, covers, and doors

Identification and location

 **NOTE:** Your product might not appear exactly as the one shown in the photos in this chapter. Although some photos do not show the document feeder and scanner assembly installed, the procedures in this chapter are appropriate for your product.

Figure 1-119 External panels, covers, doors, and scanner assembly; identification and location

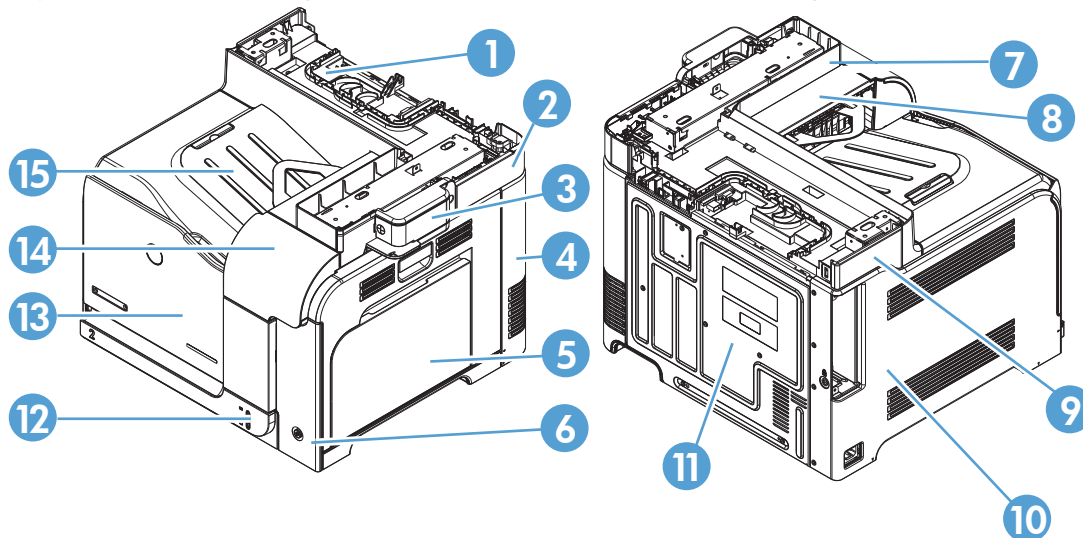

Table 1-2 External panels, covers, doors, and scanner assembly; identification and location

Item	Description
1	Rear-top cover (see Rear-top cover on page 112)
2	Right-top cover (see Right-top cover on page 106)
3	Stapler cover (see Stapler cover on page 85)
4	Right-rear cover (see Right-rear cover on page 90)
5	Right-door assembly (see Right-door assembly on page 86)
6	Right-front cover (see Right-front cover on page 100)
7	Upper-right cover (see Upper-right cover on page 108)
8	Delivery cover (see Delivery cover on page 104)
9	Left-upper cover (see Left-upper cover on page 97)
10	Left cover (see Left cover on page 92)
11	Rear cover (see Rear cover on page 98)
12	Tray (see Tray 2 and 3 on page 23)
13	Front-door assembly (see Front-door assembly on page 37)
14	Front-upper cover (see Front-upper cover on page 83)
15	Front-top cover (see Front-top cover on page 110)

Control-panel USB cover

- ▲ Remove the small cover from USB port on the left side of the control panel.

Figure 1-120 Remove USB cover



Control-panel HIP (hardward integration pocket)

Use a small flat blade screwdriver to carefully separate the cover from the product.

⚠ CAUTION: There are two tabs along each of the long edges of the cover that fasten the cover to the product. Do not break the tabs when the cover is removed.

Figure 1-121 Remove the HIP cover



Front-upper cover

Remove the front-upper cover

1. Open the right door and front door.

Figure 1-122 Remove the front-upper cover (1 of 4)



2. Remove one screw.

Figure 1-123 Remove the front-upper cover (2 of 4)



3. Remove one screw.

Figure 1-124 Remove the front-upper cover (3 of 4)



4. Lift the cover up, and then remove the front-upper cover.

 **NOTE:** The cover might be difficult to remove. It might require some flexing to release it.

Figure 1-125 Remove the front-upper cover (4 of 4)



Stapler cover

Remove the stapler cover

- ▲ Remove one screw and then the stapler cover.

Figure 1-126 Remove the stapler cover



Right-door assembly

1. Open the right-door assembly.

Figure 1-127 Remove the right-door assembly (1 of 8)

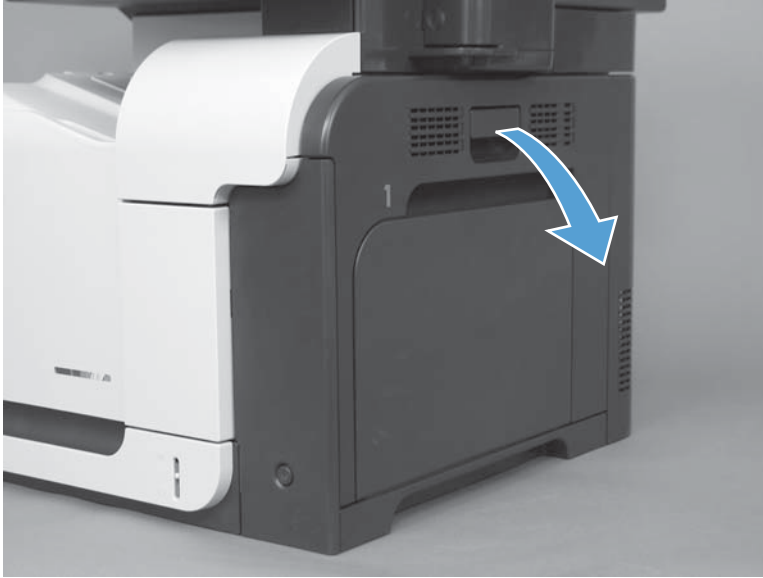

2. Close the secondary transfer assembly.

Figure 1-128 Remove the right-door assembly (2 of 8)

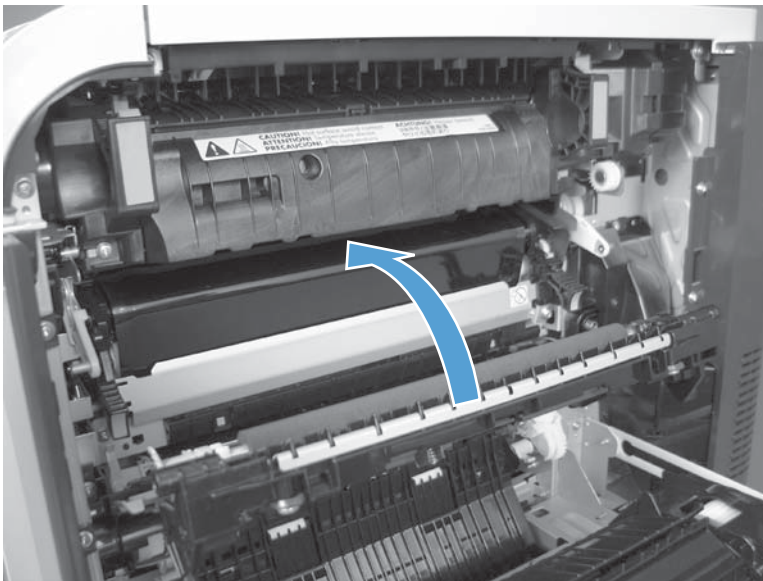

3. Remove three screws (callout 1).

Figure 1-129 Remove the right-door assembly (3 of 8)

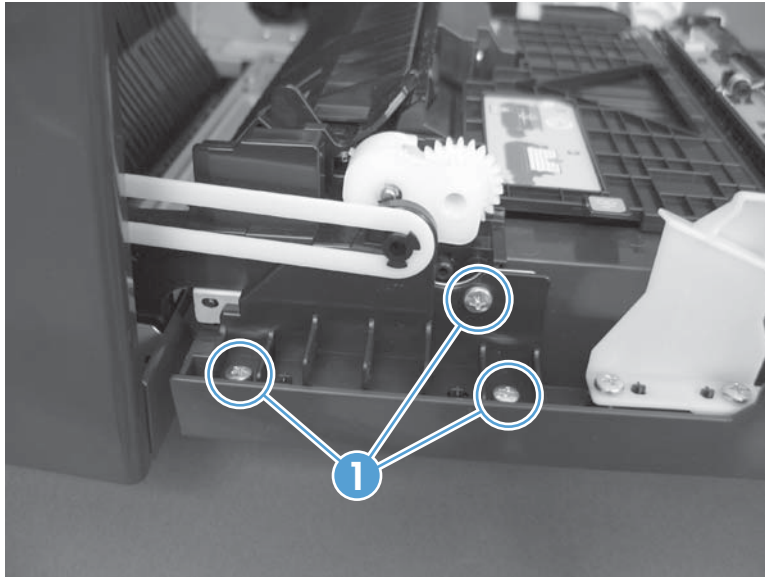

4. Carefully release one link arm.

Figure 1-130 Remove the right-door assembly (4 of 8)



5. Remove one screw (callout 1), and then remove the cover (callout 2).

Figure 1-131 Remove the right-door assembly (5 of 8)

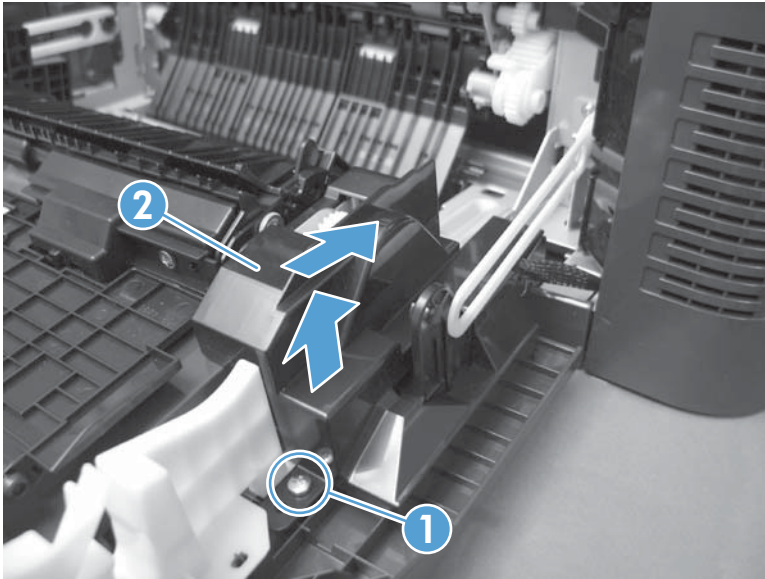

6. Disconnect two connectors (callout 1), and then release the wire harness from the guide (callout 2).

 **TIP:** It is easier to disconnect the lower connector if you first remove the wire harnesses from the guide.

Figure 1-132 Remove the right-door assembly (6 of 8)



7. Remove two screws (callout 1).

Figure 1-133 Remove the right-door assembly (7 of 8)

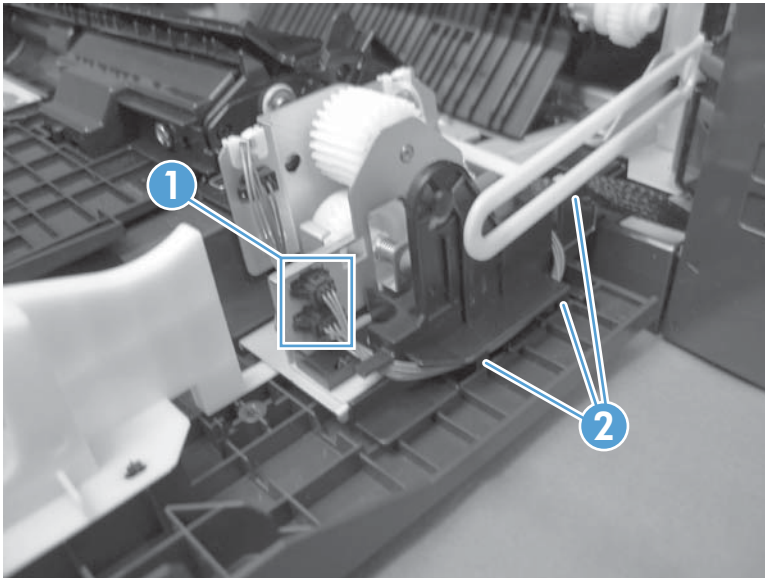
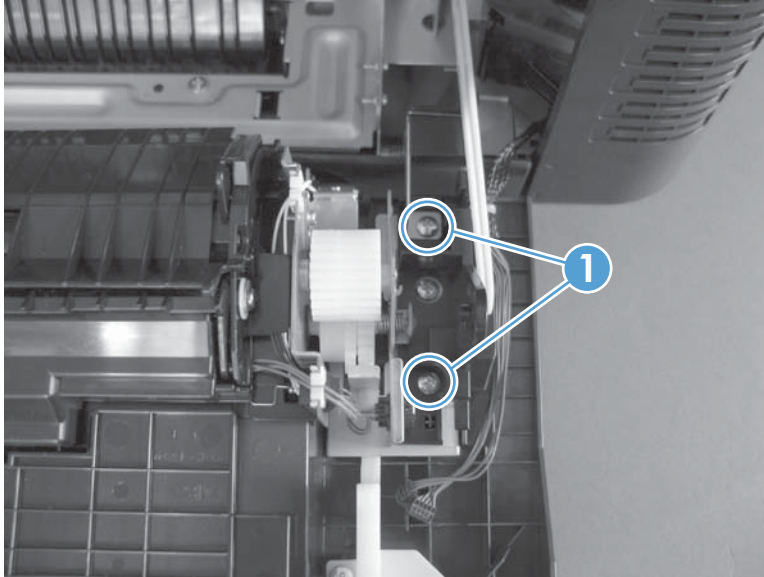

8. Remove the right-door assembly.

Figure 1-134 Remove the right-door assembly (8 of 8)

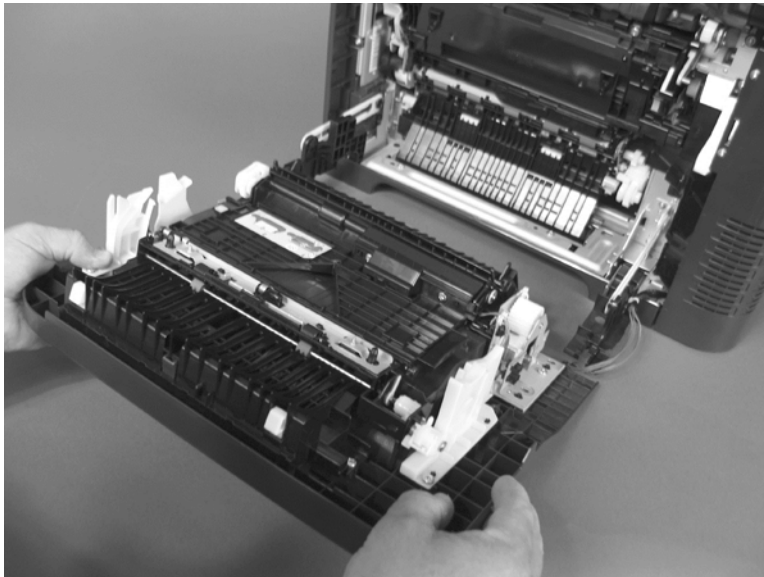

Right-rear cover

1. Open the right-door assembly.

Figure 1-135 Remove the right-rear cover (1 of 3)

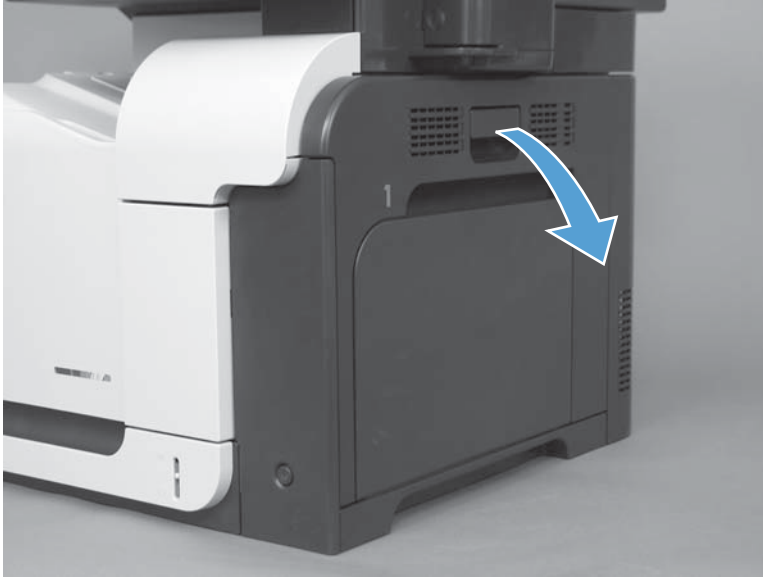

2. Remove two screws (callout 1) and release one tab (callout 2).

Figure 1-136 Remove the right-rear cover (2 of 3)

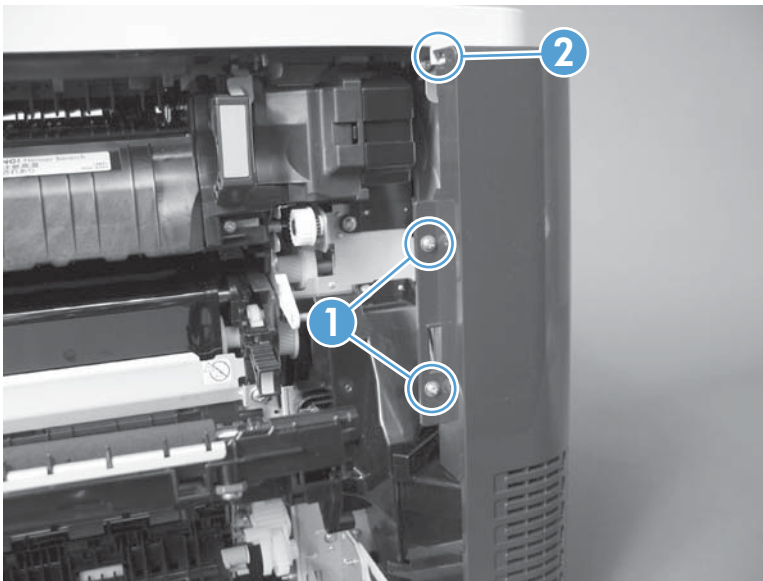

3. Rotate the bottom of the cover away from the product, and then remove the cover.

Figure 1-137 Remove the right-rear cover (3 of 3)

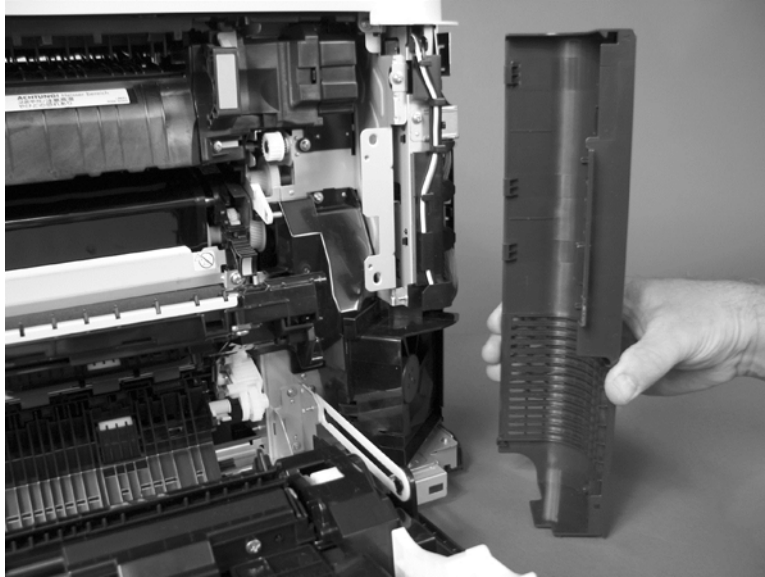

Left cover

1. Remove four screws (callout 1).

Figure 1-138 Remove the left cover (1 of 5)

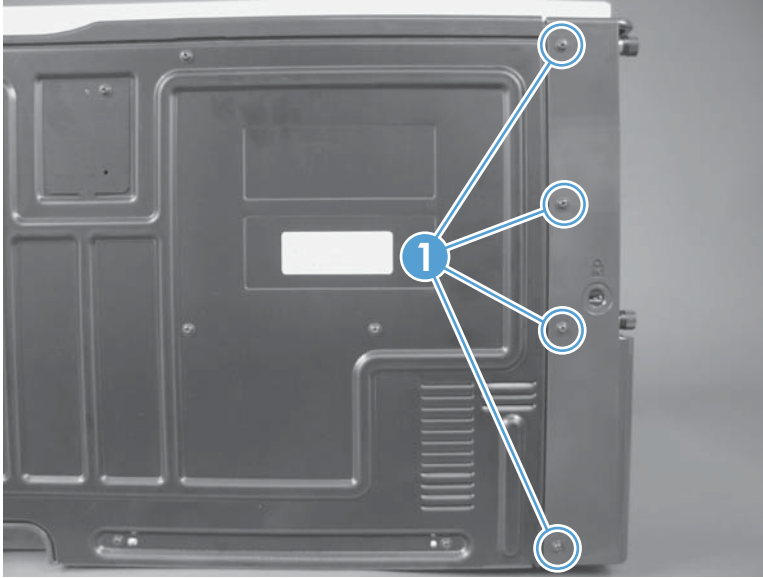

2. Release the rear edge of the cover, and slightly separate the cover from the product.

Figure 1-139 Remove the left cover (2 of 5)



3. The figure below shows the cover removed so that you can see the tab locations. **Before proceeding**, note the location of the mounting tabs.

CAUTION: One tab (callout 2) is easily damaged when removing the cover. Be careful when removing the cover.

Figure 1-140 Remove the left cover (3 of 5)

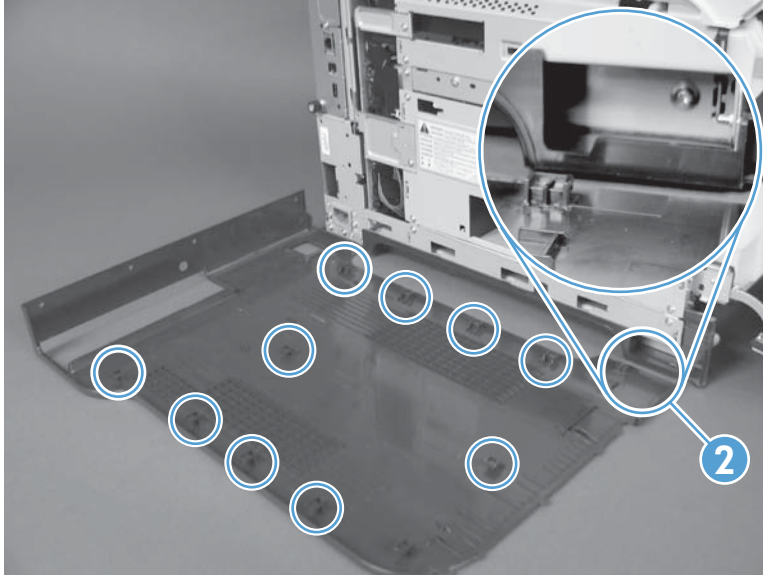

4. Use your thumb to press in on the lower-front portion of the cover (near the dashed circle in the figure below), and then slightly slide the cover away from the front door to release one tab.

CAUTION: You must flex the cover enough to release the front edge of the cover, but do not damage the tab at the bottom-front edge of the cover. See callout 2 in [Figure 1-140 Remove the left cover \(3 of 5\) on page 93](#).

Figure 1-141 Remove the left cover (4 of 5)

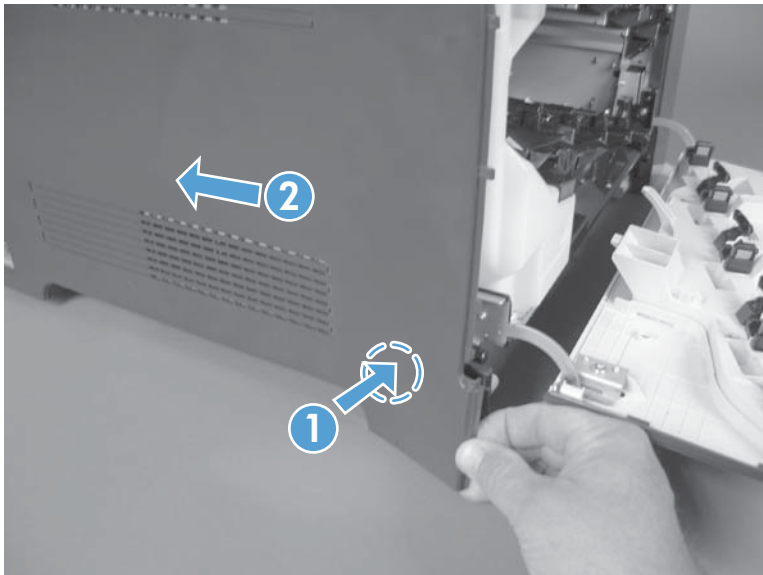

5. Slide the cover toward the rear of the product and rotate it away from the product and then remove the cover.

Figure 1-142 Remove the left cover (5 of 5)

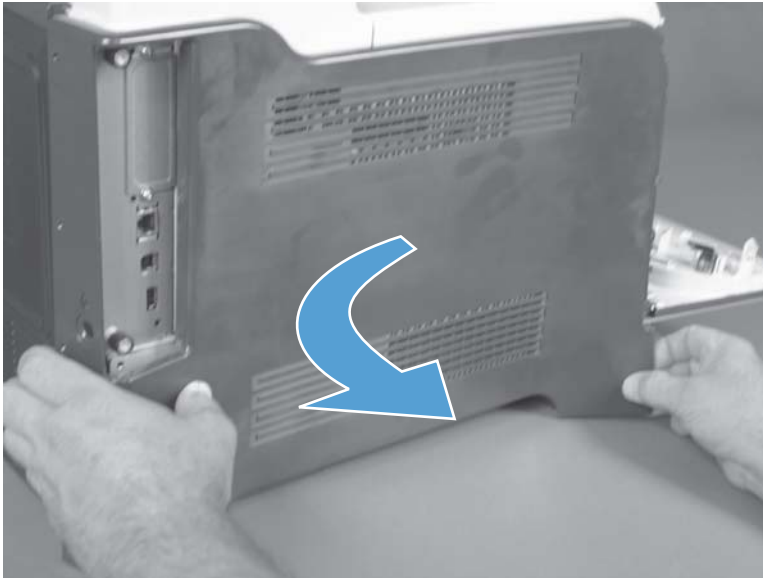

Rear-upper cover

1. Note the location of the three tabs.

Figure 1-143 Remove the rear-upper cover (1 of 3)

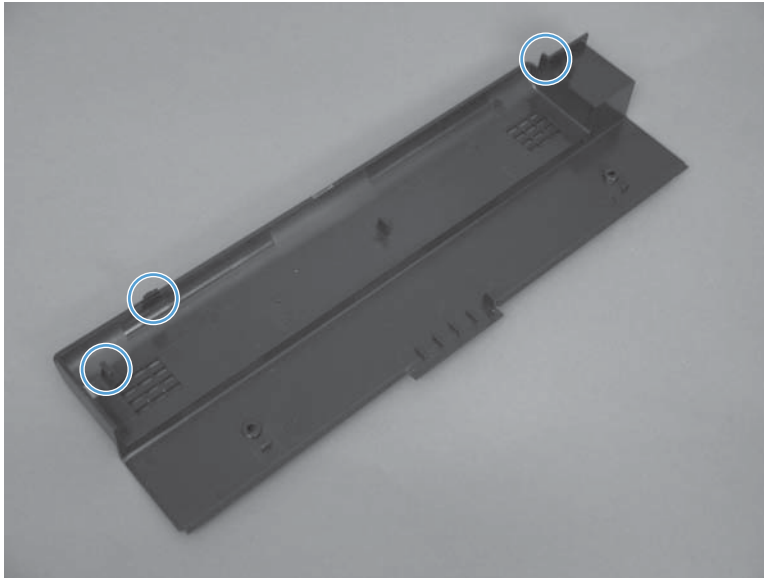

2. Remove two screws (callout 1). Push in to release the tabs.

Figure 1-144 Remove the rear-upper cover (2 of 3)

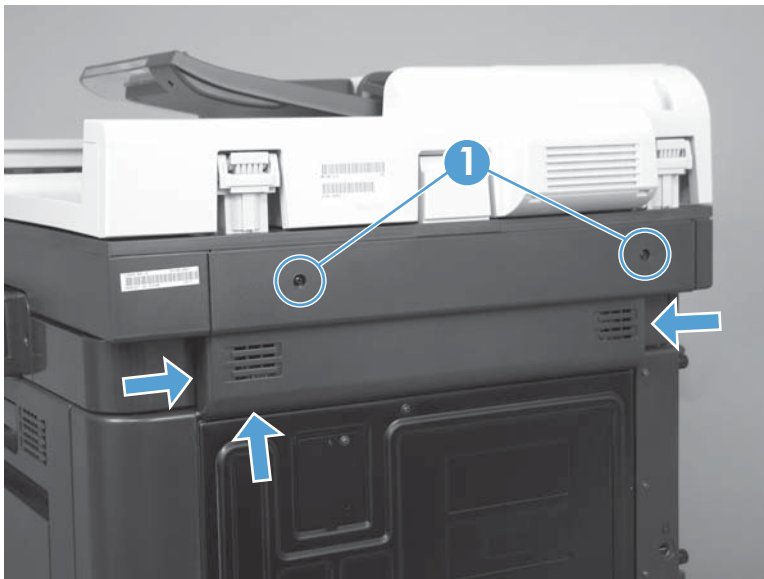

3. Rotate the cover away from the product to remove.

Figure 1-145 Remove the rear-upper cover (3 of 3)



Left-upper cover

Before proceeding, remove the following components:

- Rear-upper cover. See [Rear-upper cover on page 95](#).

Remove the left-upper cover

- ▲ Release one tab and remove the cover.

Figure 1-146 Remove the left-upper cover

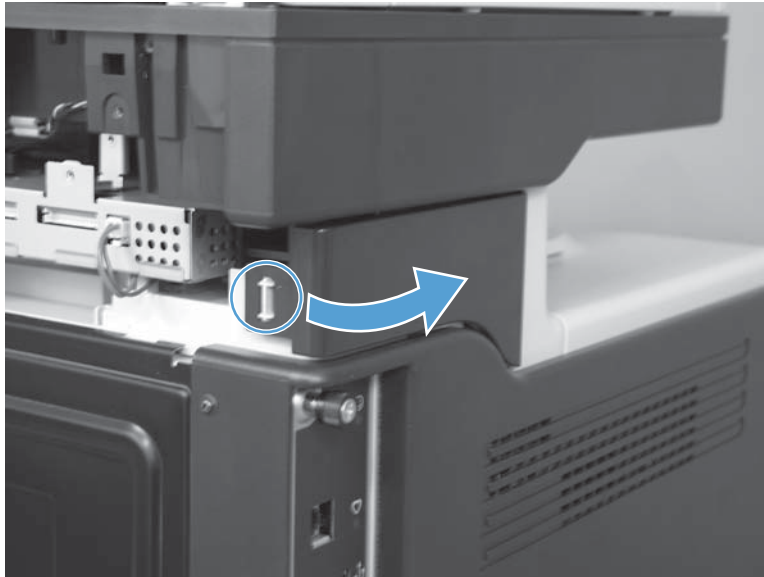

Rear cover

Before proceeding, remove the following components:

- Right-rear cover. See [Right-rear cover on page 90](#).
- Left cover. See [Left cover on page 92](#).
- Rear-upper cover. See [Rear-upper cover on page 95](#).

Remove the rear cover

1. Remove eight screws (callout 1).

Figure 1-147 Remove the rear cover (1 of 2)

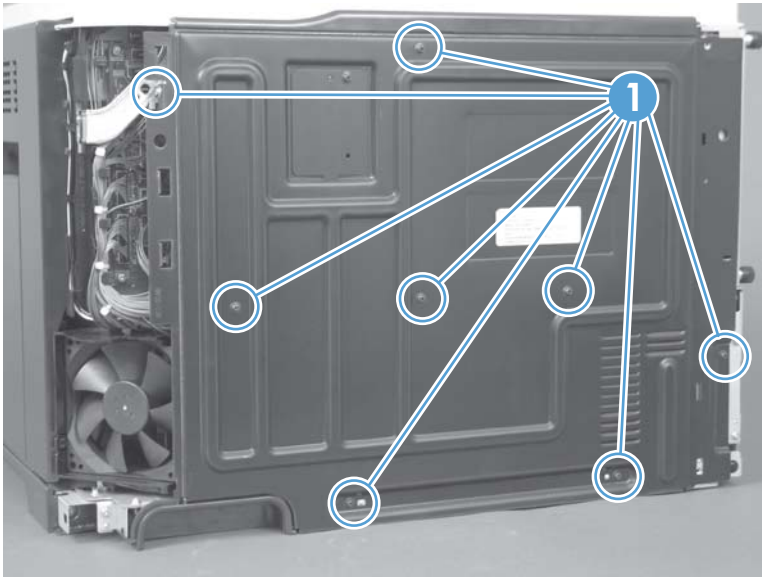

2. Slide the cover toward the fan side of the product, and then remove the rear cover.

Figure 1-148 Remove the rear cover (2 of 2)



Right-front cover

Before proceeding, remove the following components:

- Front-upper cover. See [Front-upper cover on page 83](#).

Remove the right-front cover

 **NOTE:** Be careful. When removing the cover, do not dislodge the power button. If the button is dislodged, see [Reinstall the power button on page 103](#) to reinstall it.

1. Remove one screw (callout 1).

Figure 1-149 Remove the right-front cover (1 of 5)

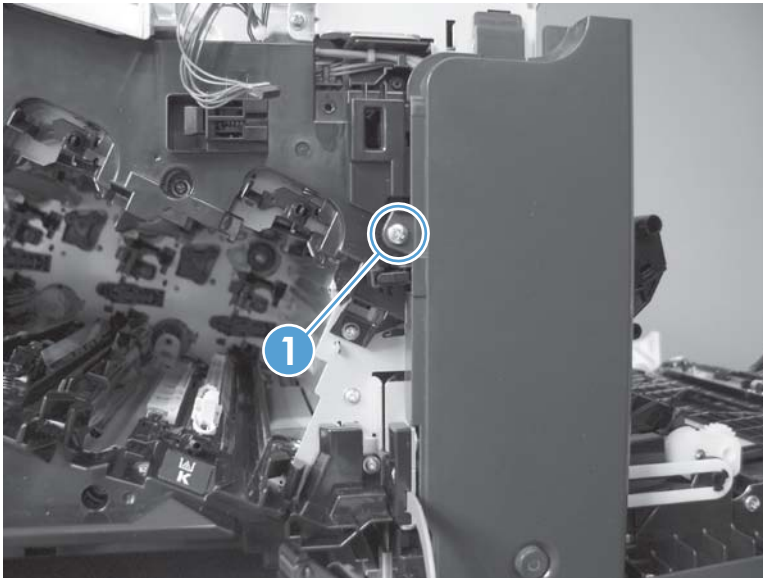

2. Remove two screws (callout 2).

Figure 1-150 Remove the right-front cover (2 of 5)

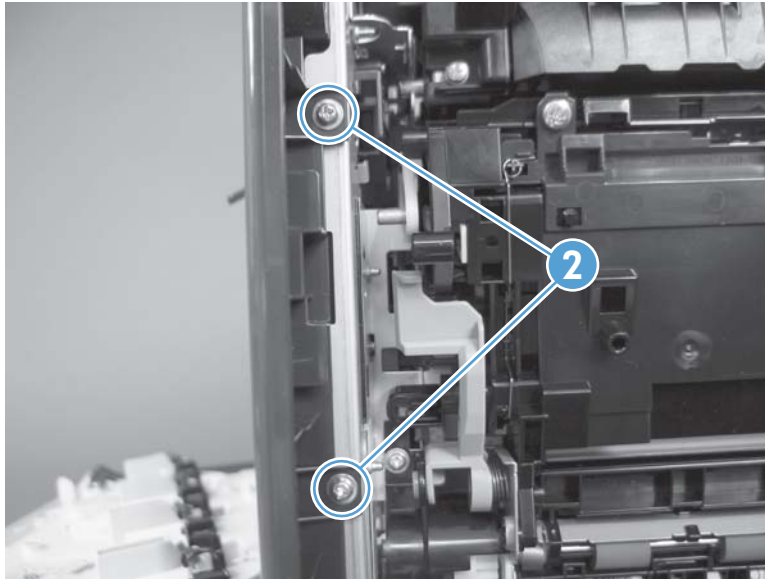

3. Before you proceed, take note of the tab locations at the bottom of the cover.

Figure 1-151 Remove the right-front cover (3 of 5)

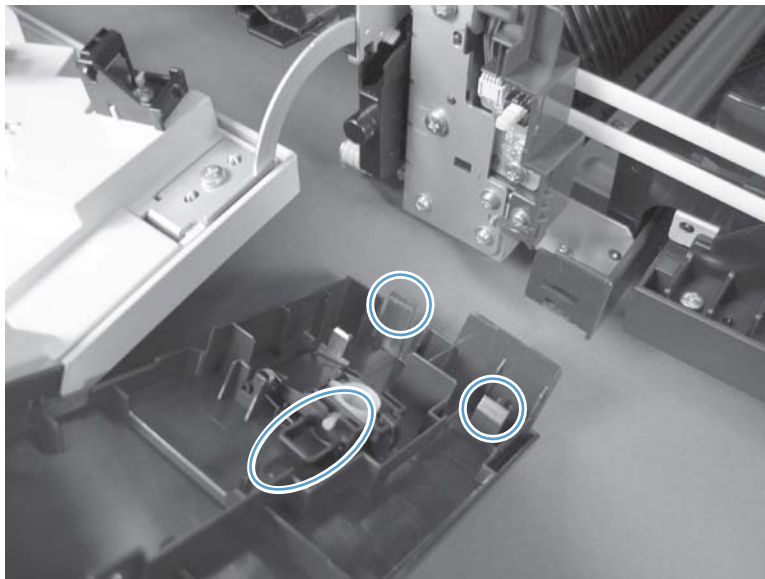

4. Pull down on the cover to release three tabs (callout 3).

 **TIP:** It might be easier if you position the product at the edge of the work surface so that there is a space for the cover to slide downward. Or, you might try inserting a small flat blade screwdriver behind the cover, and carefully pry the cover away from the product as you pull down on the cover to release the tabs.

Figure 1-152 Remove the right-front cover (4 of 5)



5. Rotate the bottom of the cover away from the product, and then pull down on the cover to remove it.

Figure 1-153 Remove the right-front cover (5 of 5)

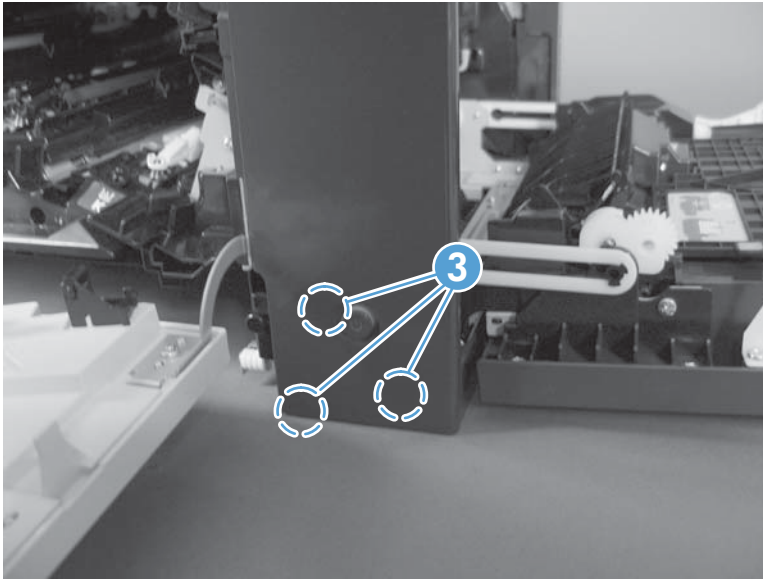
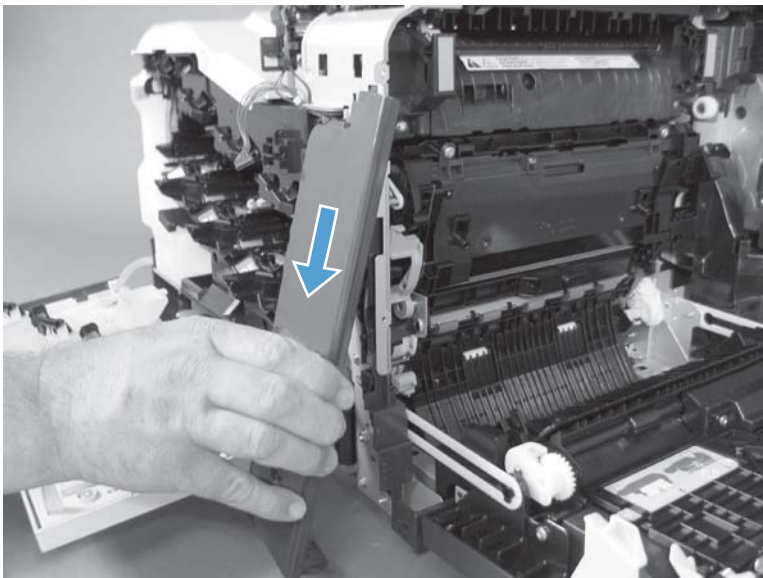

Reinstall the power button

Snap the power button into the holders on the cover. Make sure that the spring is correctly installed.

Figure 1-154 Reinstall the power button

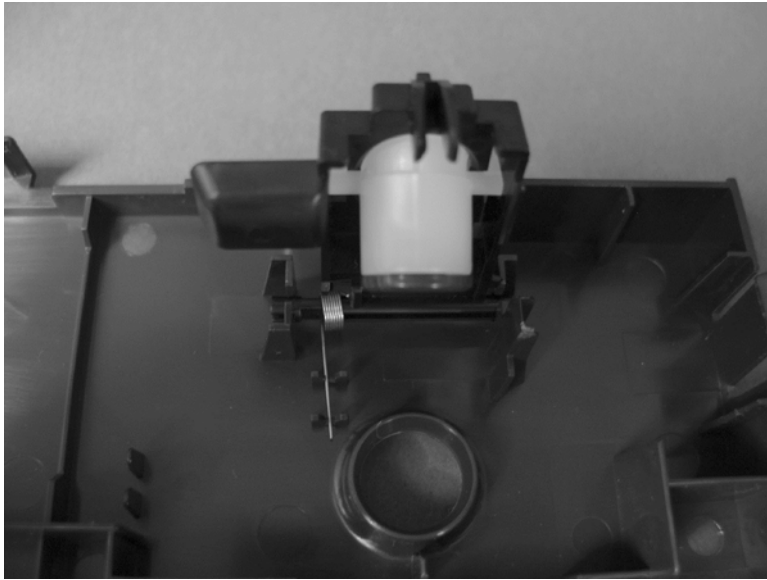

Delivery cover

Before proceeding, remove the following components:

- Front-upper cover. See [Front-upper cover on page 83](#).
- Stapler cover. See [Stapler cover on page 85](#).
- Rear-upper cover. See [Rear-upper cover on page 95](#).
- Left-upper cover. See [Left-upper cover on page 97](#).
- Upper-right cover. See [Upper-right cover on page 108](#).
- Document feeder whole unit.
 - See [Document feeder whole unit on page 127](#).
 - See [Document feeder whole unit \(M575c model\) on page 130](#).
- Scanner-control board (SCB).
 - See [Scanner-control board \(SCB\) on page 133](#).
 - See [Scanner-control board \(SCB; M575c\) on page 136](#).
- Image scanner whole unit. See [Image scanner whole unit on page 139](#).

Remove the delivery cover

1. Remove three screws.

Figure 1-155 Remove the delivery cover (1 of 3)

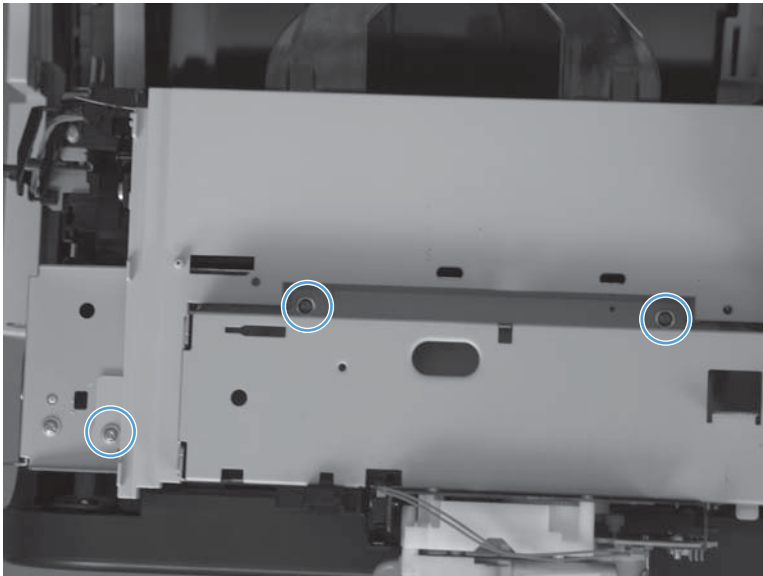

2. Lift up (callout 1) and slide the delivery cover (callout 2).

Figure 1-156 Remove the delivery cover (2 of 3)

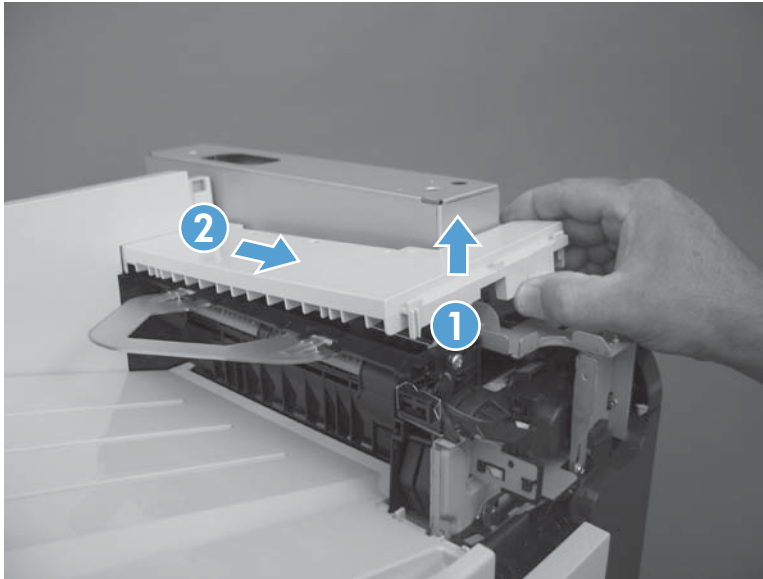

3. Remove the delivery cover.

Figure 1-157 Remove the delivery cover (3 of 3)

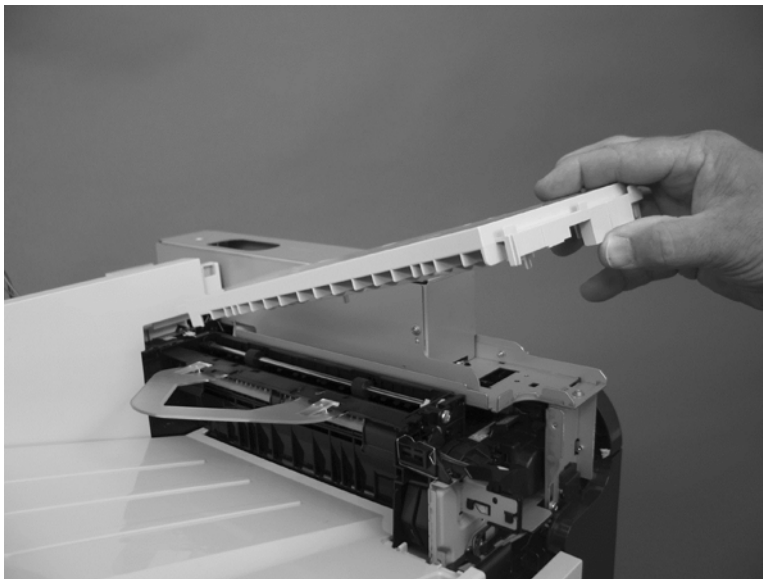

Right-top cover

Before proceeding, remove the following components:

- Stapler cover. See [Stapler cover on page 85](#).
- Rear-upper cover. See [Rear-upper cover on page 95](#).
- Left-upper cover. See [Left-upper cover on page 97](#).
- Document feeder whole unit.
 - See [Document feeder whole unit on page 127](#).
 - See [Document feeder whole unit \(M575c model\) on page 130](#).
- Scanner-control board (SCB).
 - See [Scanner-control board \(SCB\) on page 133](#).
 - See [Scanner-control board \(SCB; M575c\) on page 136](#).
- Image scanner whole unit. See [Image scanner whole unit on page 139](#).

Remove the right-top cover

1. Remove three screws.

Figure 1-158 Remove the right-top cover (1 of 2)

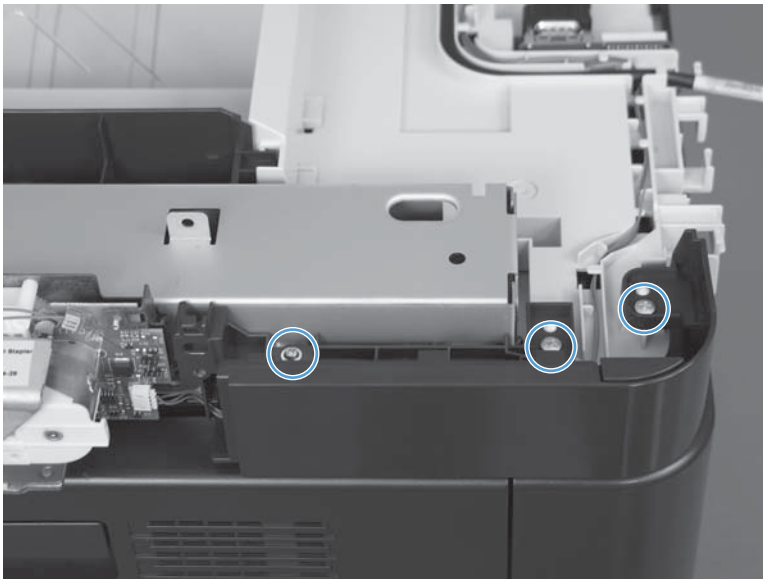

2. Disconnect one connector (callout 1), remove the wire harness from its retainer (callout 2), and remove the cover.

Figure 1-159 Remove the right-top cover (2 of 2)

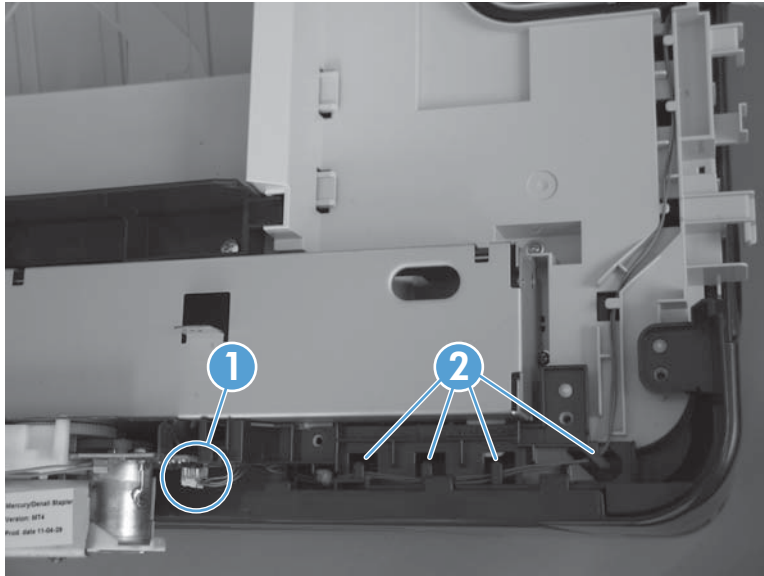

Upper-right cover

Before proceeding, remove the following components:

- Stapler cover. See [Stapler cover on page 85](#).
- Rear-upper cover. See [Rear-upper cover on page 95](#).
- Left-upper cover. See [Left-upper cover on page 97](#).
- Document feeder whole unit.
 - See [Document feeder whole unit on page 127](#).
 - See [Document feeder whole unit \(M575c model\) on page 130](#).
- Scanner-control board (SCB).
 - See [Scanner-control board \(SCB\) on page 133](#).
 - See [Scanner-control board \(SCB; M575c\) on page 136](#).
- Image scanner whole unit. See [Image scanner whole unit on page 139](#).

Remove the upper-right cover

1. Remove one screw.

Figure 1-160 Remove the upper-right cover (1 of 2)

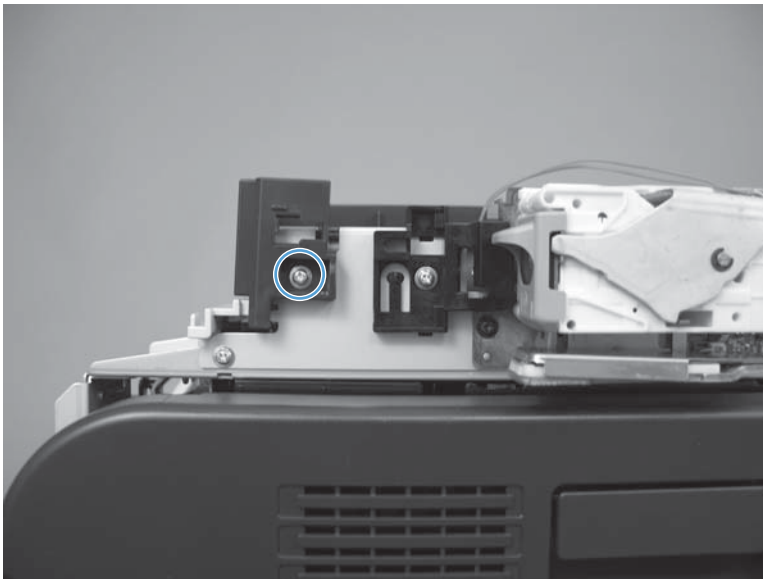

2. Remove two screws, and remove the cover.

Figure 1-161 Remove the upper-right cover (2 of 2)

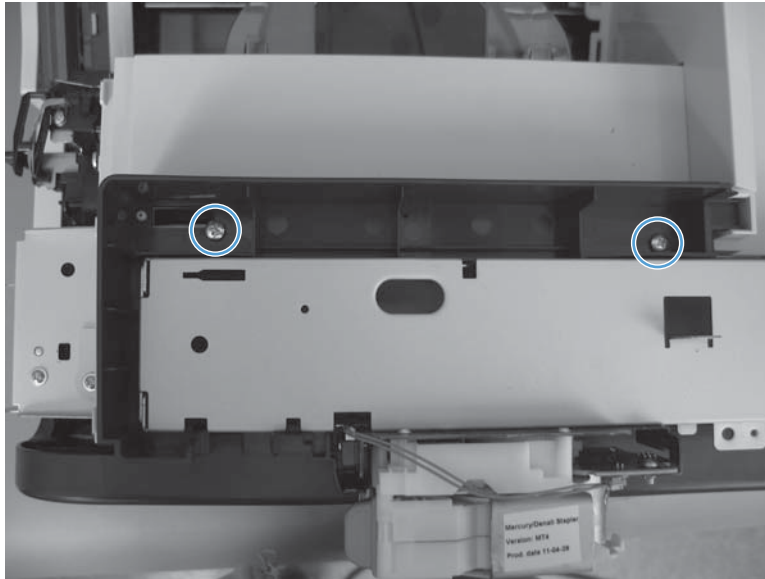

Front-top cover

Before proceeding, remove the following components:

- Front-upper cover. See [Front-upper cover on page 83](#).
- Stapler cover. See [Stapler cover on page 85](#).
- Rear-upper cover. See [Rear-upper cover on page 95](#).
- Left-upper cover. See [Left-upper cover on page 97](#).
- Left cover. See [Left cover on page 92](#).
- Document feeder whole unit.
 - See [Document feeder whole unit on page 127](#).
 - See [Document feeder whole unit \(M575c model\) on page 130](#).
- Scanner-control board (SCB).
 - See [Scanner-control board \(SCB\) on page 133](#).
 - See [Scanner-control board \(SCB; M575c\) on page 136](#).
- Image scanner whole unit. See [Image scanner whole unit on page 139](#).

Remove the front-top cover

1. Remove one screw (callout 1).

Figure 1-162 Remove the front-top cover (1 of 2)

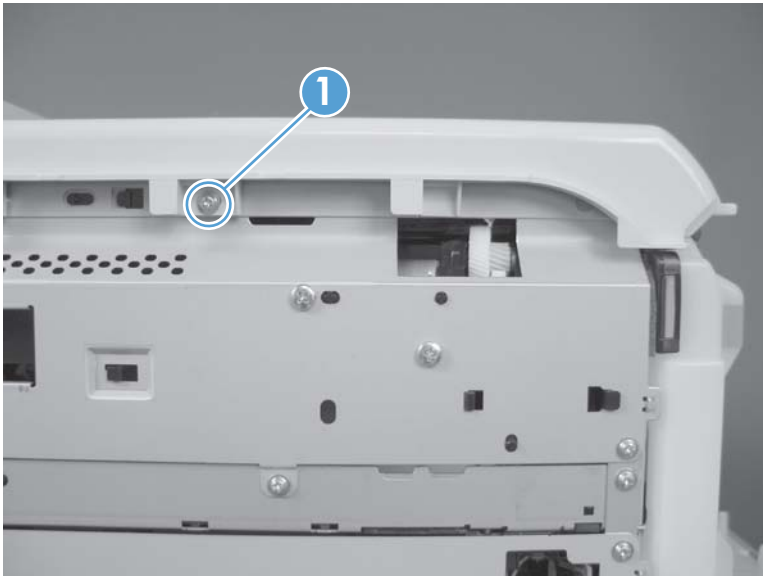

2. Slide the cover toward the left side of the product to release it, and then remove the cover.

Figure 1-163 Remove the front-top cover (2 of 2)

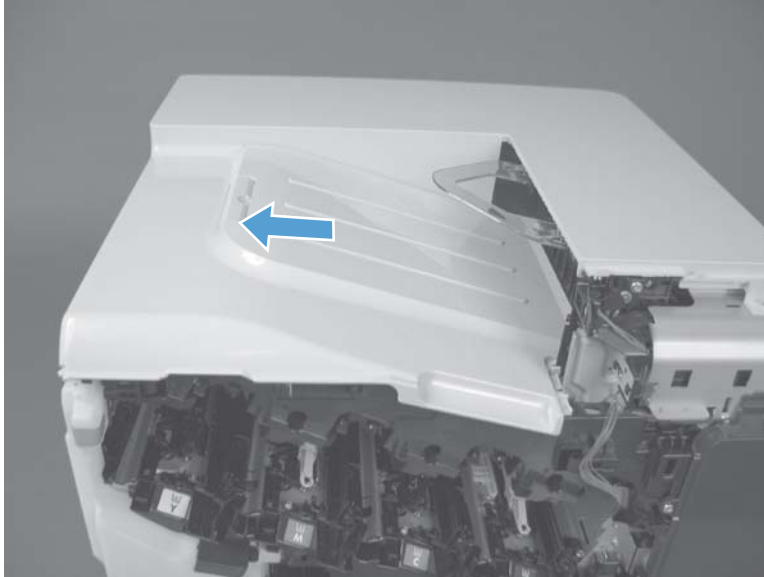

Rear-top cover

Before proceeding, remove the following components:

- Stapler cover. See [Stapler cover on page 85](#).
- Rear-upper cover. See [Rear-upper cover on page 95](#).
- Left-upper cover. See [Left-upper cover on page 97](#).
- Rear cover. See [Rear cover on page 98](#).
- Delivery cover. See [Delivery cover on page 104](#).
- Front-top cover. See [Front-top cover on page 110](#).
- Document feeder whole unit.
 - See [Document feeder whole unit on page 127](#).
 - See [Document feeder whole unit \(M575c model\) on page 130](#).
- Scanner-control board (SCB).
 - See [Scanner-control board \(SCB\) on page 133](#).
 - See [Scanner-control board \(SCB; M575c\) on page 136](#).
- Image scanner whole unit. See [Image scanner whole unit on page 139](#).

Remove the rear-top cover

1. Release the wire harness from its retainers (callout 1), and disconnect the cable (callout 2).

Figure 1-164 Remove the rear-top cover (1 of 2)

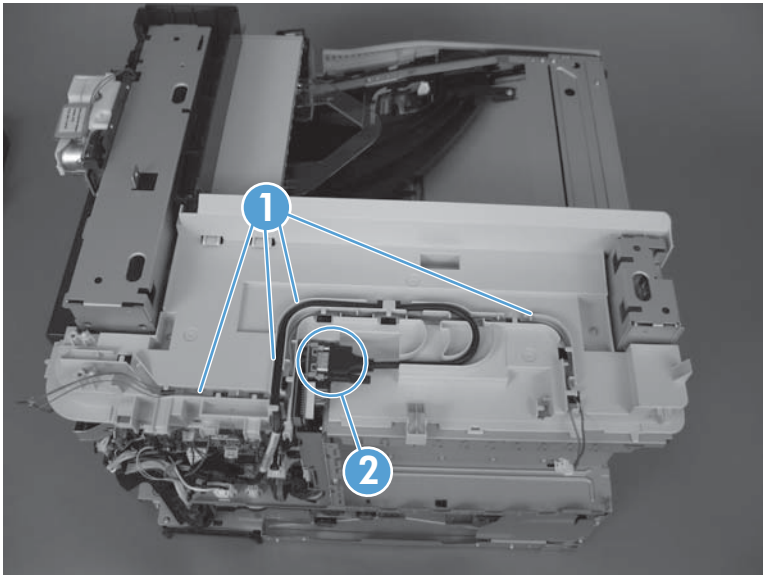

2. Remove three screws, and then remove the cover.

Figure 1-165 Remove the rear-top cover (2 of 2)

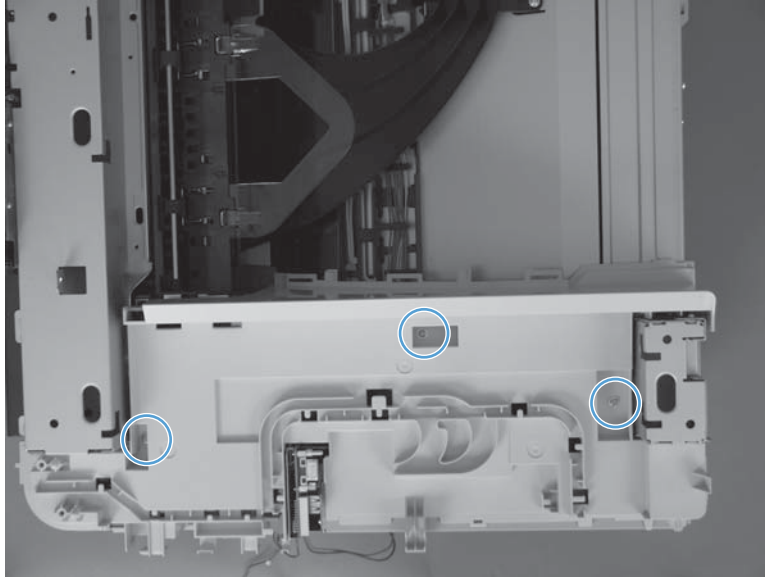

Document feeder and scanner assemblies

Cover front (document feeder front cover)

1. Open the jam-access cover.

Figure 1-166 Remove the document feeder front cover (1 of 4)

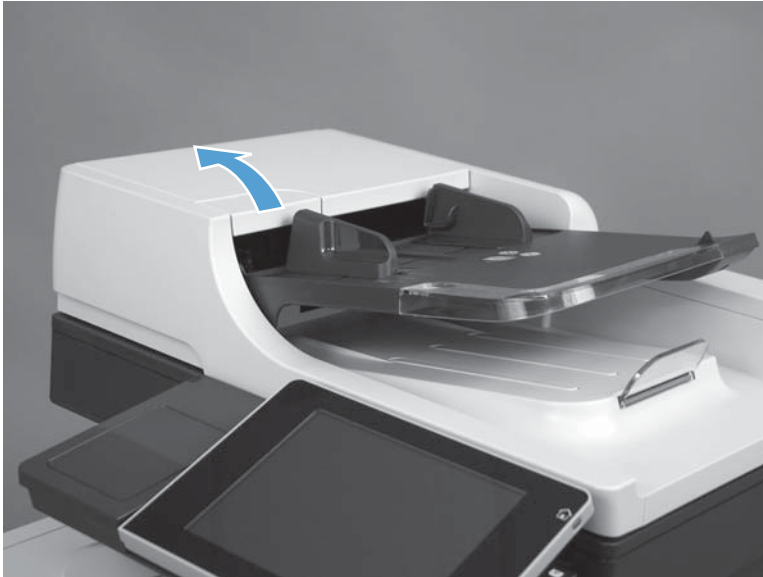

2. Remove two screws.

Figure 1-167 Remove the document feeder front cover (2 of 4)

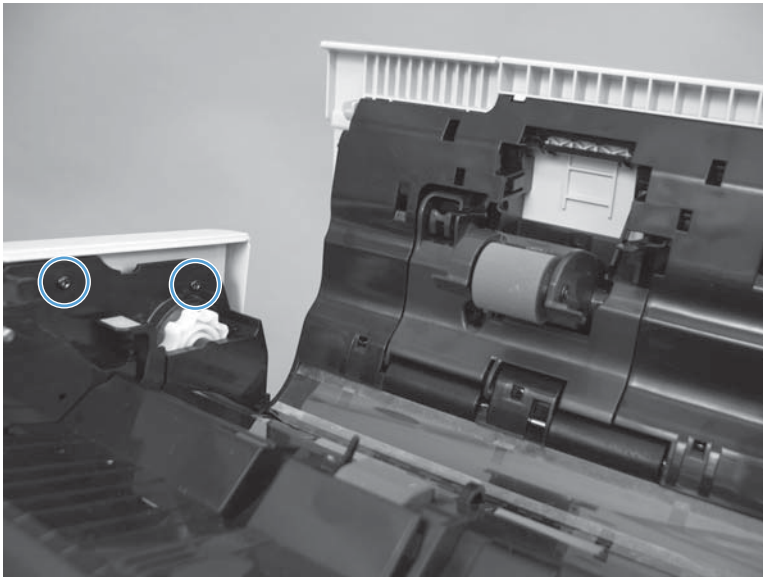

3. Open the document feeder, and then remove four screws.

Figure 1-168 Remove the document feeder front cover (3 of 4)

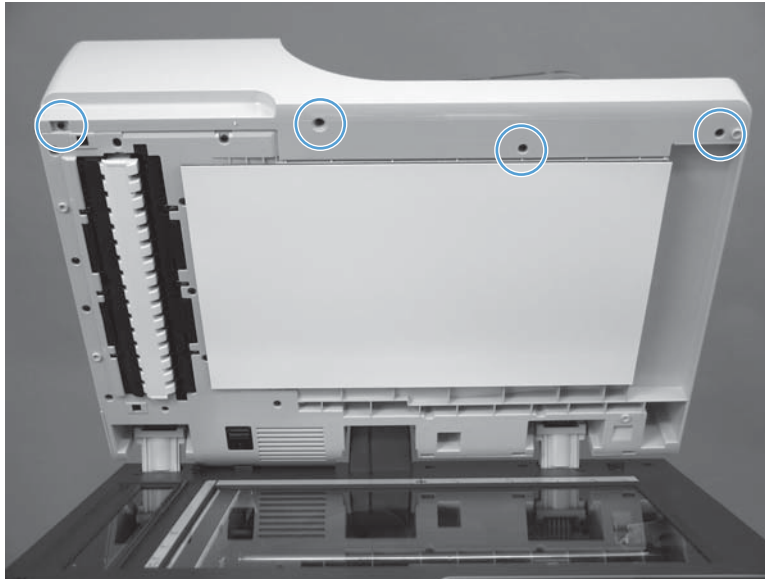

4. Release one tab (callout 1), and then remove the cover.

Figure 1-169 Remove the document feeder front cover (4 of 4)

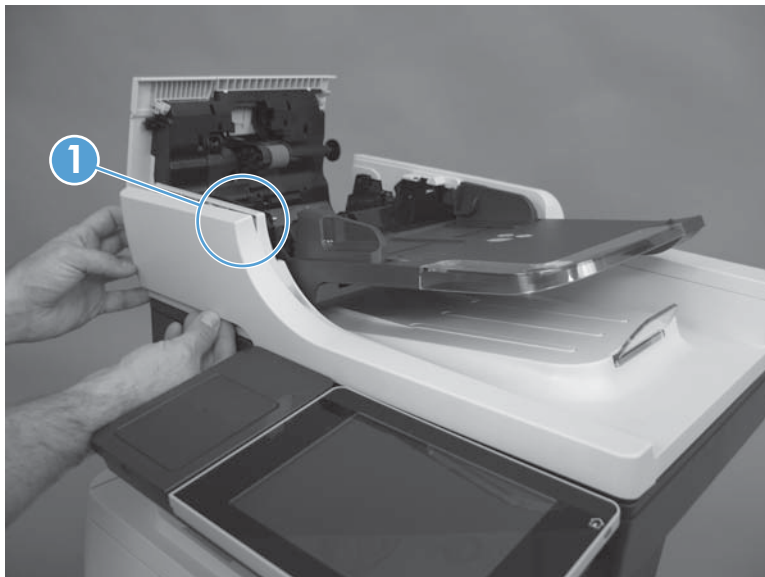

Cover rear (document feeder rear cover)

1. Open the document feeder, and then remove three screws.

Figure 1-170 Remove the document feeder rear cover (1 of 4)

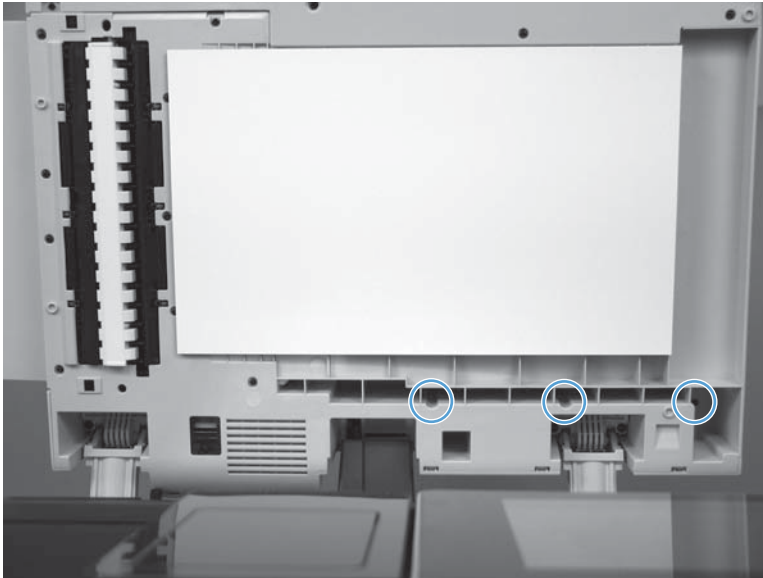

2. Close the document feeder and then open the jam-access cover.

Figure 1-171 Remove the document feeder rear cover (2 of 4)

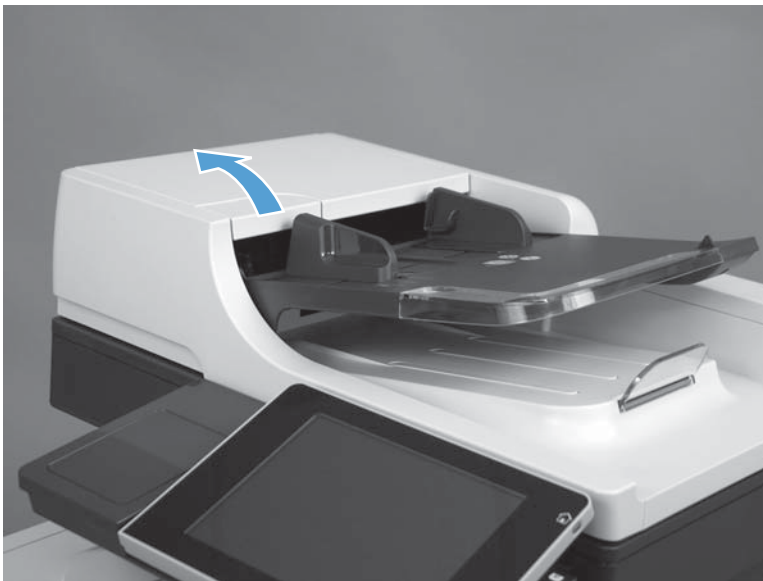

3. Remove two screws.

Figure 1-172 Remove the document feeder rear cover (3 of 4)

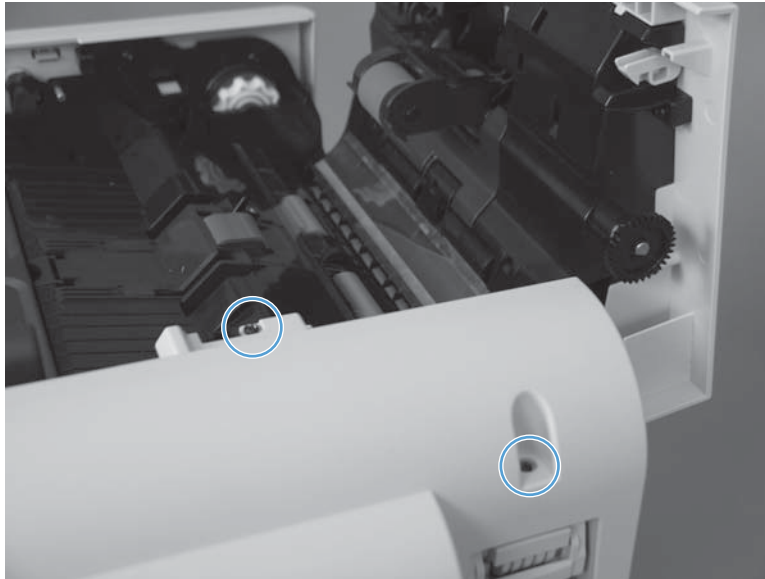

4. Release six tabs and remove the cover.

Figure 1-173 Remove the document feeder rear cover (4 of 4)

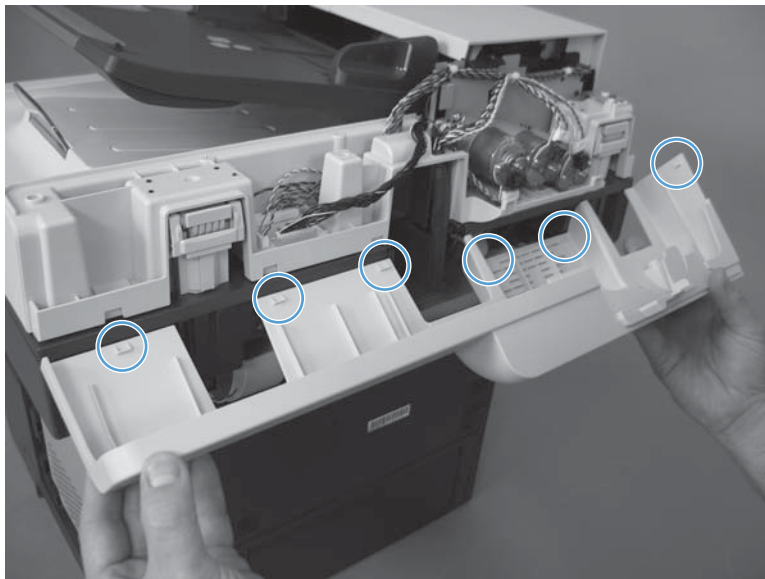

Deskew mylar and separation mylar

1. Open the jam-access cover.

Figure 1-174 Remove the deskew mylar and separation mylar (1 of 3)

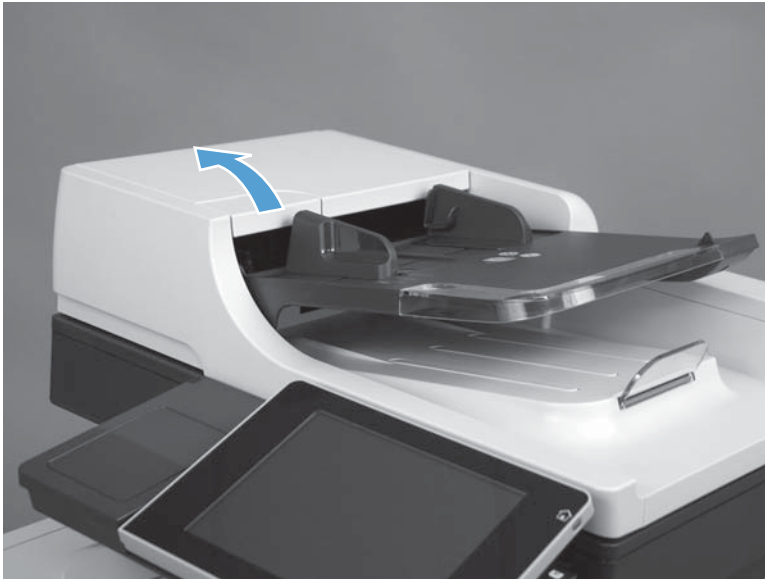

2. Carefully peel off the deskew mylar

Figure 1-175 Remove the deskew mylar and separation mylar (2 of 3)

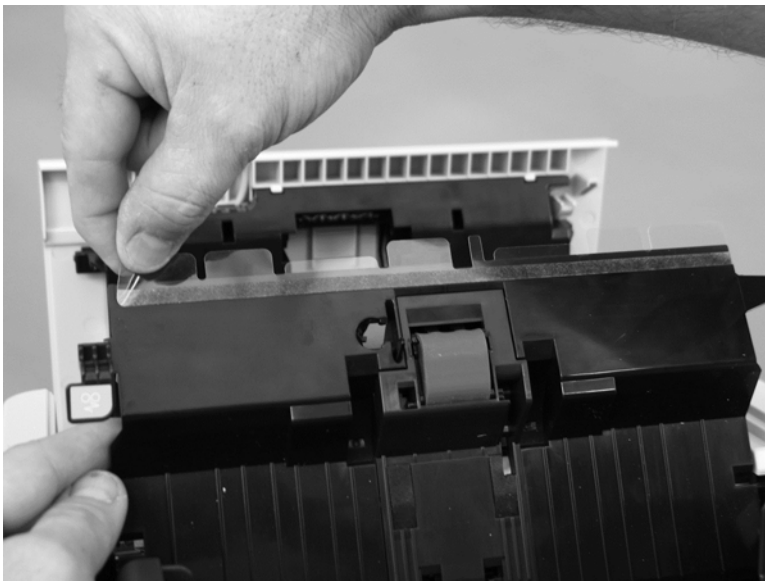

3. Carefully peel off the separation mylar.

Figure 1-176 Remove the deskew mylar and separation mylar (3 of 3)



Document feeder tray extender

1. Peel the foam reflector back, and then remove four screws.

Figure 1-177 Remove the document feeder tray extender (1 of 2)

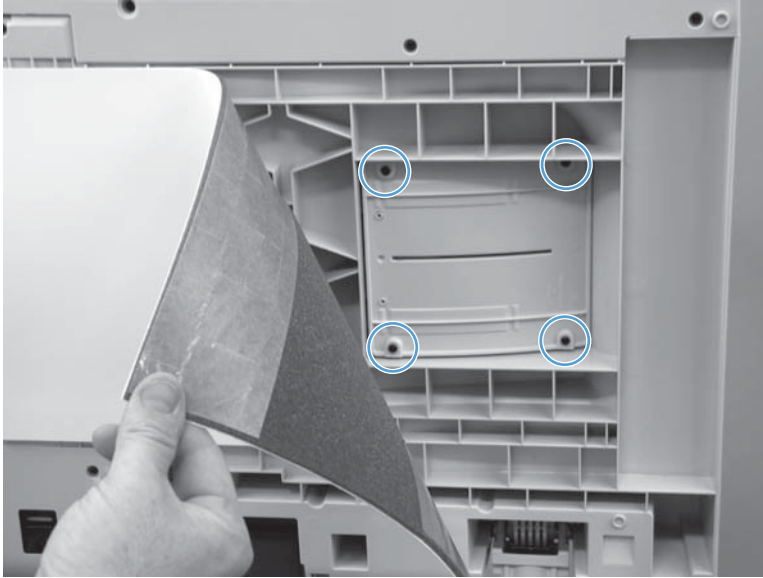

2. Pull the document feeder tray extender away from the product to remove.

Figure 1-178 Remove the document feeder tray extender (2 of 2)

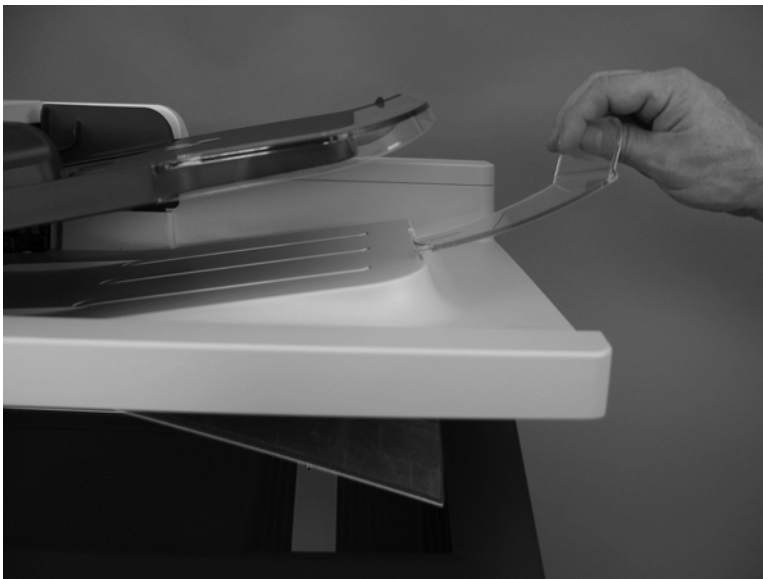

Document feeder jam-access cover

1. Open the document feeder jam-access cover.

Figure 1-179 Remove the document feeder jam-access cover (1 of 5)

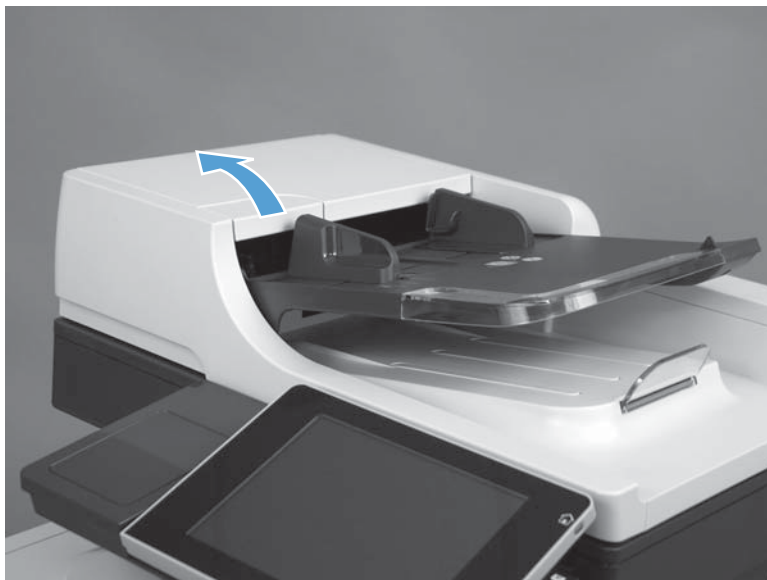

2. Remove four screws.

Figure 1-180 Remove the document feeder jam-access cover (2 of 5)

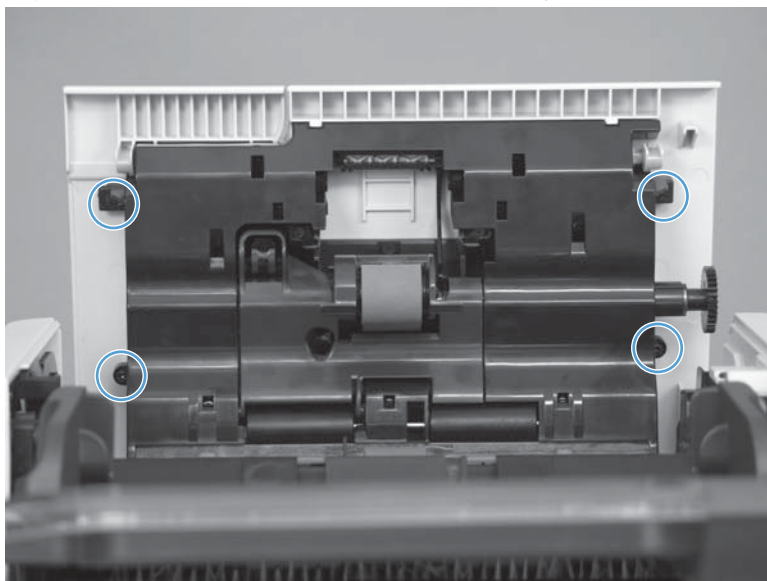

3. Before removing the cover, note the location of the tabs.

Figure 1-181 Remove the document feeder jam-access cover (3 of 5)

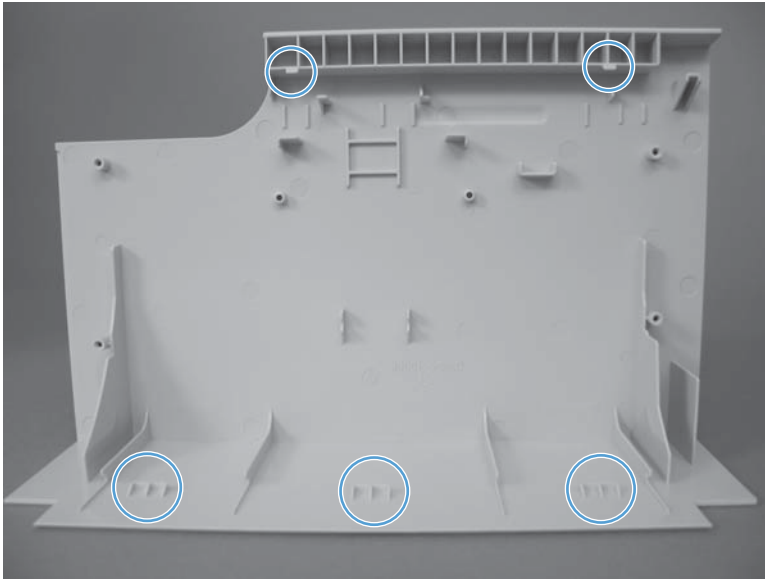

4. Release two tabs.

Figure 1-182 Remove the document feeder jam-access cover (4 of 5)

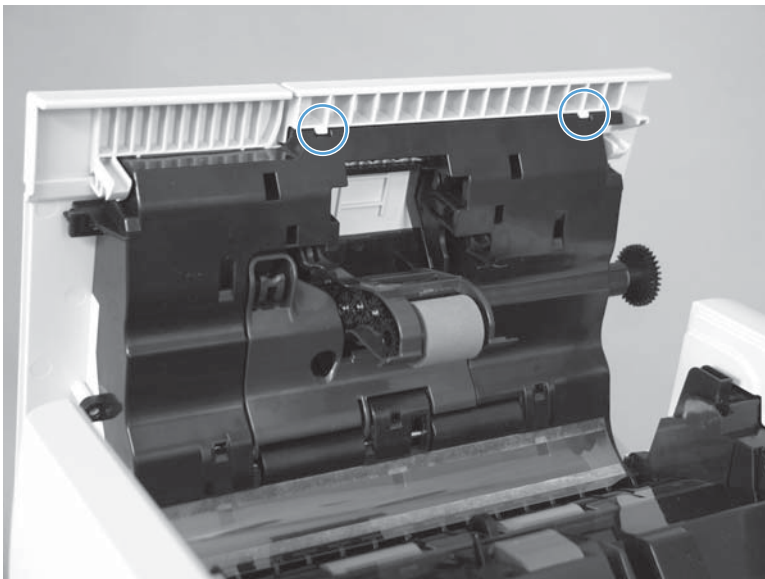

5. Close the document feeder jam-access cover, and then release the remaining three tabs and remove the cover.

Figure 1-183 Remove the document feeder jam-access cover (5 of 5)



Document feeder roller cover

1. Before proceeding, remove the following:
 - Document feeder jam-access cover. See [Document feeder jam-access cover on page 121](#).
2. Remove three springs.

 **Reinstallation tip** Use needle nose pliers to reattach the spring. Attach the spring to the bottom hook first.

Figure 1-184 Remove the document feeder roller cover (1 of 4)



3. Lift and slide the rod.

Figure 1-185 Remove the document feeder roller cover (2 of 4)

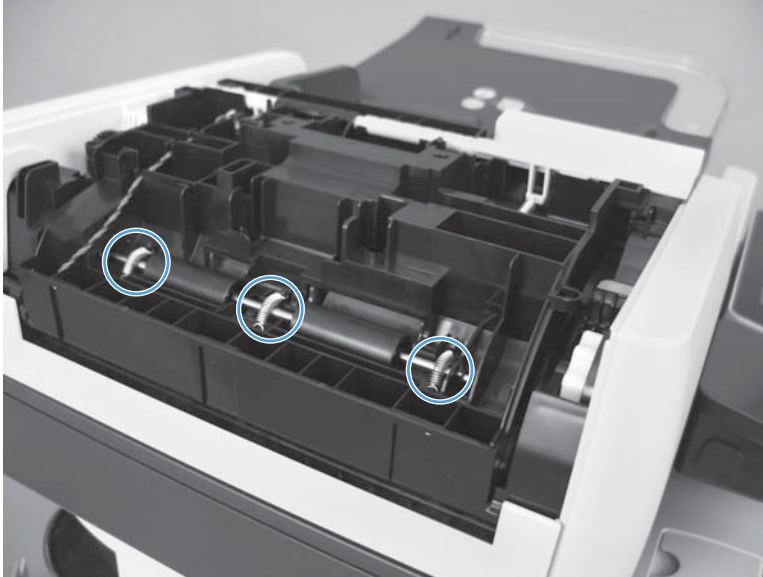

4. Open the document feeder jam access cover. Release one hinge.

Figure 1-186 Remove the document feeder roller cover (3 of 4)

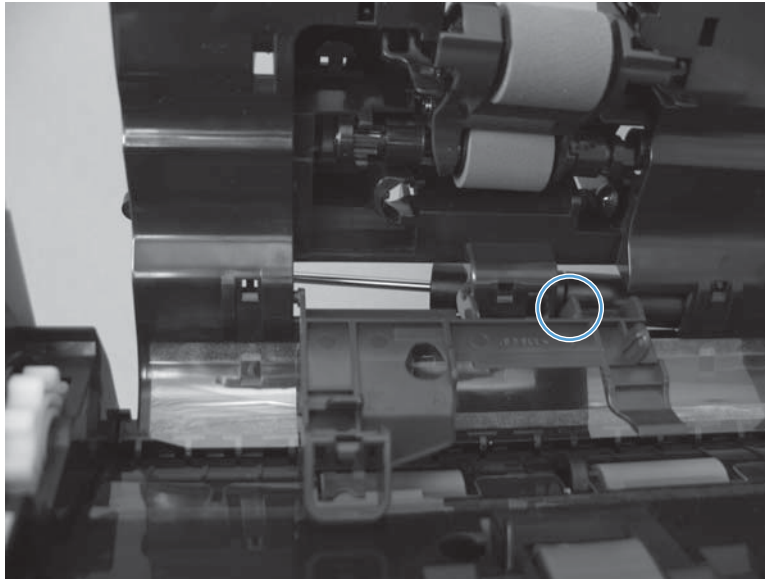

5. Remove the document feeder roller cover.

Figure 1-187 Remove the document feeder roller cover (4 of 4)

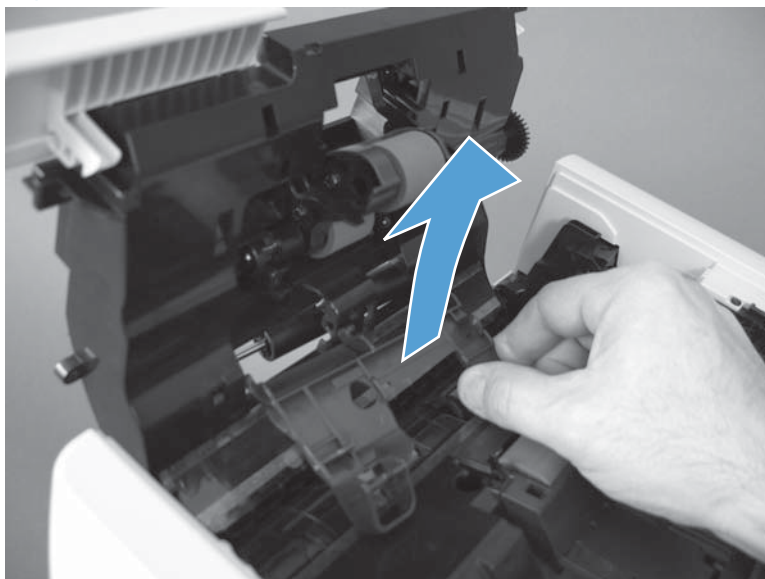

Reinstall the document feeder roller cover

- ▲ Make sure the rod for the roller is installed in the correct position (callout 1).

Figure 1-188 Reinstall the document feeder roller cover

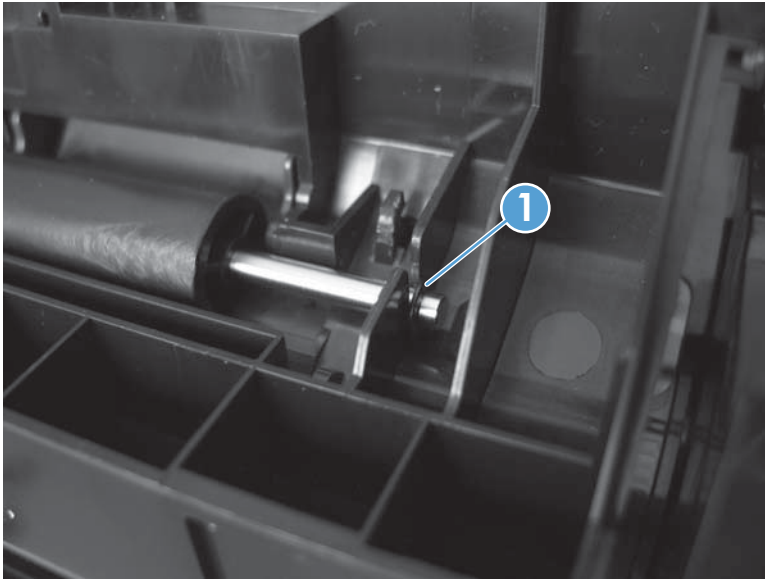

Document feeder whole unit

Before proceeding, remove the following:

- Rear-upper cover. See [Rear-upper cover on page 95](#).
- Foam reflector kit. See [Foam reflector kit on page 38](#).

 **NOTE:** After removing the document feeder assembly, place it on a clean, dry, and smooth surface.

You must replace the foam reflector kit and calibrate the scanner.

1. Remove four screws (callout 1), release three connectors (callout 2), and remove the document feeder cable cover (callout 3).

Figure 1-189 Remove the document feeder assembly (1 of 2)

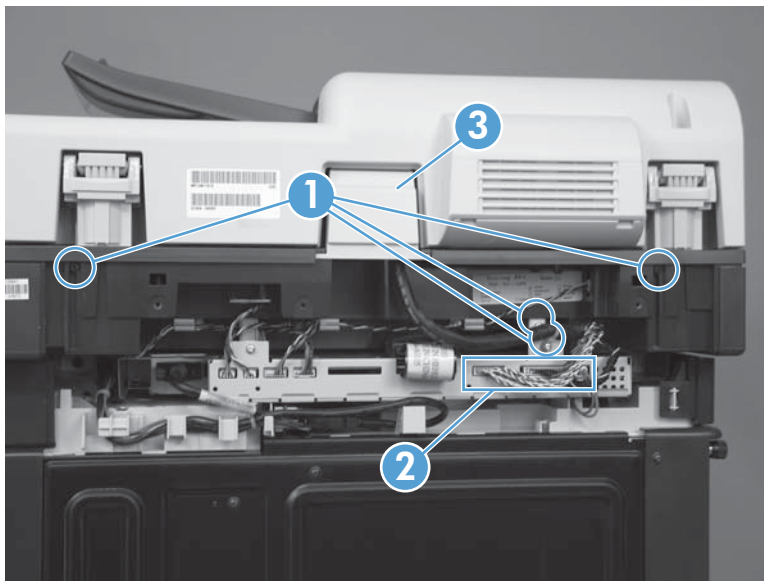

2. Open the document feeder. Lift the assembly straight up until it stops (callout 1), and then slightly tilt it (callout 2) toward the rear of the product. Continue lifting the assembly straight up to remove it.

Figure 1-190 Remove the document feeder assembly (2 of 2)

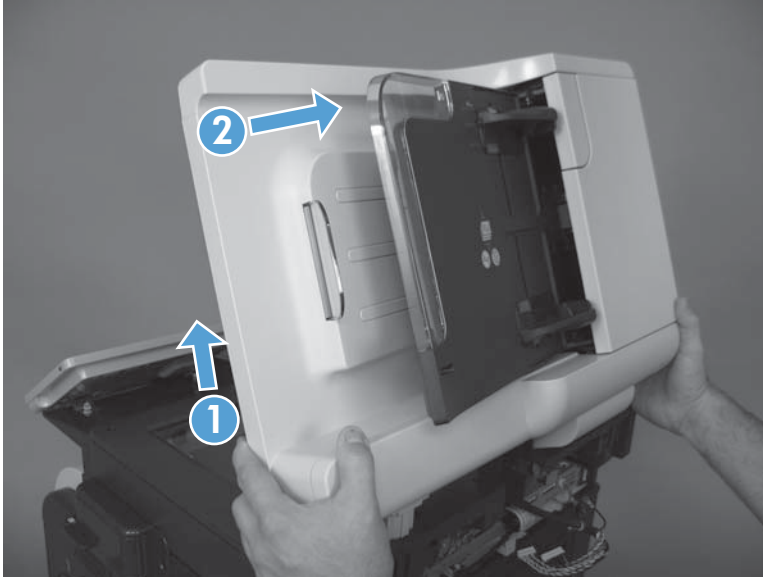

Reinstall the document feeder

Install a foam reflector kit on the new document feeder

- ▲ If a replacement document feeder, image scanner, or both assemblies are installed, you must install a replacement foam reflector kit. See [Foam reflector kit on page 38](#).

Calibrate a replacement document feeder assembly

1. On the control-panel Home screen, scroll to and touch [Device Maintenance](#).
2. Touch [Calibration/Cleaning](#).
3. Touch [Calibrate Scanner](#).
4. Follow the instructions on the control-panel display.

Document feeder whole unit (M575c model)

Before proceeding, remove the following assemblies:

- Rear-upper cover. See the product repair manual.
- Foam reflector kit. See the product repair manual.

Remove the document feeder

1. Remove four screws (callout 1), release three connectors (callout 2), disconnect one FFC (callout 3), and then remove the document feeder cable cover (callout 4).

 **NOTE:** Carefully thread the FFC through, and out of, the ferrite core.

 **Reinstallation tip** When the document feeder is reinstalled, it might be easier to thread the FFC through the ferrite core if you first remove the ferrite core from the holder.

Figure 1-191 Remove the document feeder assembly (M575c model; 1 of 2)



2. Open the document feeder. Lift the assembly straight up until it stops (callout 1), and then slightly tilt it (callout 2) toward the rear of the product. Continue lifting the assembly straight up to remove it.

Figure 1-192 Remove the document feeder assembly (M575c model; 2 of 2)

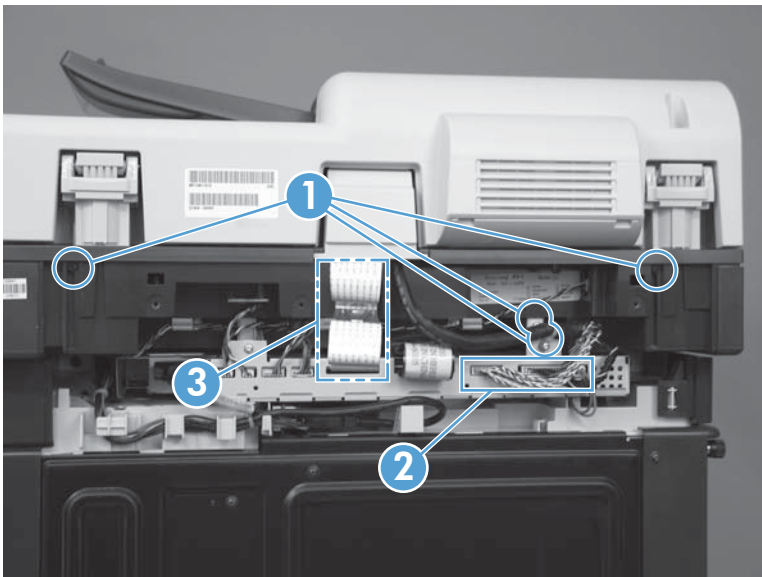
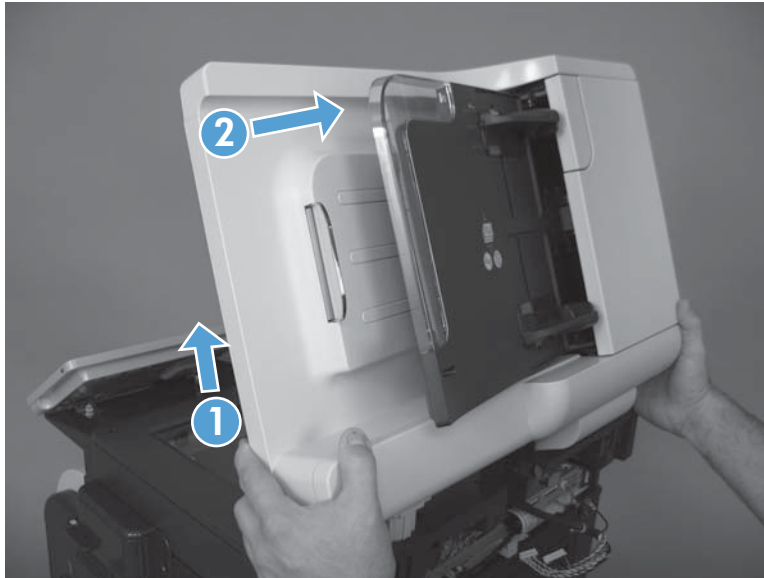

Reinstall the document feeder

Install a foam reflector kit on the new document feeder

- ▲ If a replacement document feeder, image scanner, or both assemblies are installed, you must install a replacement foam reflector kit. See [Foam reflector kit on page 38](#).

Calibrate a replacement document feeder

1. On the control-panel Home screen, scroll to and touch [Device Maintenance](#).
2. Touch [Calibration/Cleaning](#).
3. Touch [Calibrate Scanner](#).
4. Follow the instructions on the control-panel display.

Document feeder hinge assy

1. Before proceeding, remove the following:
 - Rear-upper cover. See [Rear-upper cover on page 95](#).
 - Foam reflector kit. See [Foam reflector kit on page 38](#).
 - Document feeder whole unit.
 - See [Document feeder whole unit on page 127](#).
 - See [Document feeder whole unit \(M575c model\) on page 130](#).
2. Remove four screws and the hinge assembly.

Figure 1-193 Remove the document feeder hinge assembly

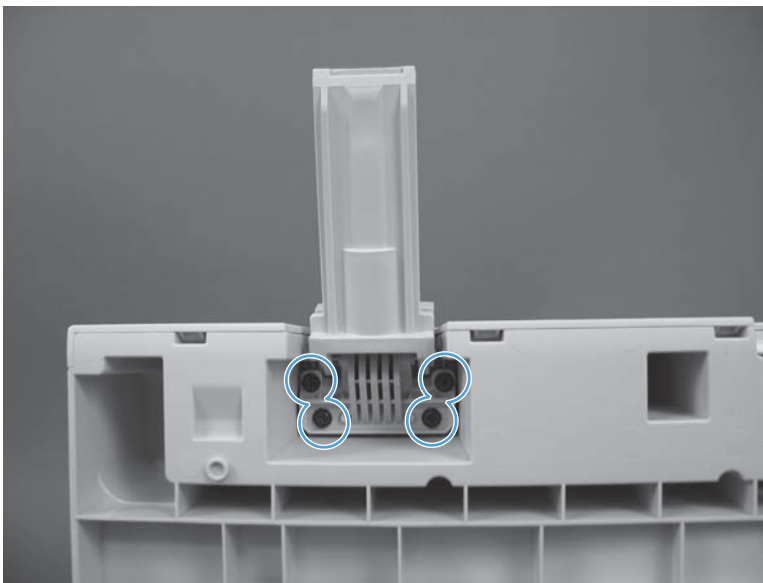

Scanner-control board (SCB)

Before proceeding, remove the following components:

- Rear-upper cover. See [Rear-upper cover on page 95](#).

Remove the SCB

1. Release eight connectors (callout 1), one FFC (callout 2), and then remove two screws (callout 3).

 **NOTE:** The scanner cable at the left-hand edge of the SCB is held in place with one thumbscrew screw.

Figure 1-194 Remove the SCB (1 of 2)



2. Slight pull the SCB out of the product, and then thread the FFC through, and out of, the ferrite core. Remove the SCB.

Figure 1-195 Remove the SCB (2 of 2)

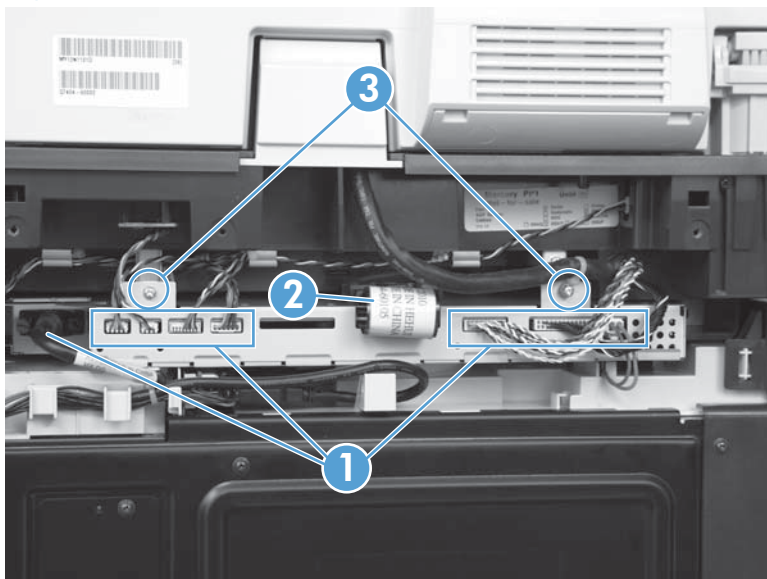
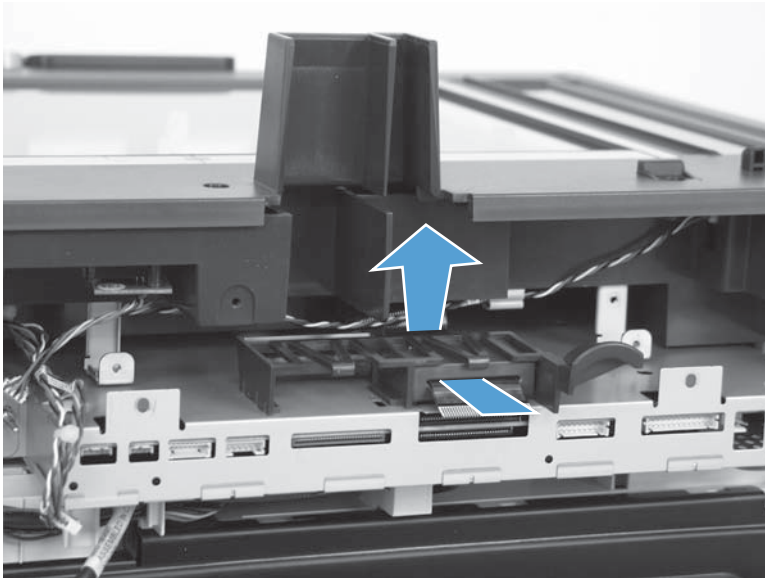

Reinstall the SCB

When reinstalling the SCB, note the locator pin for the scanner cable. It might be easier to install the scanner cable with a screw driver.

⚠ WARNING! Do not over tighten the screw when installing the cable. Over tightening the screw can cause the nut to shear off of the SCB cage.

Figure 1-196 Reinstalling the SCB

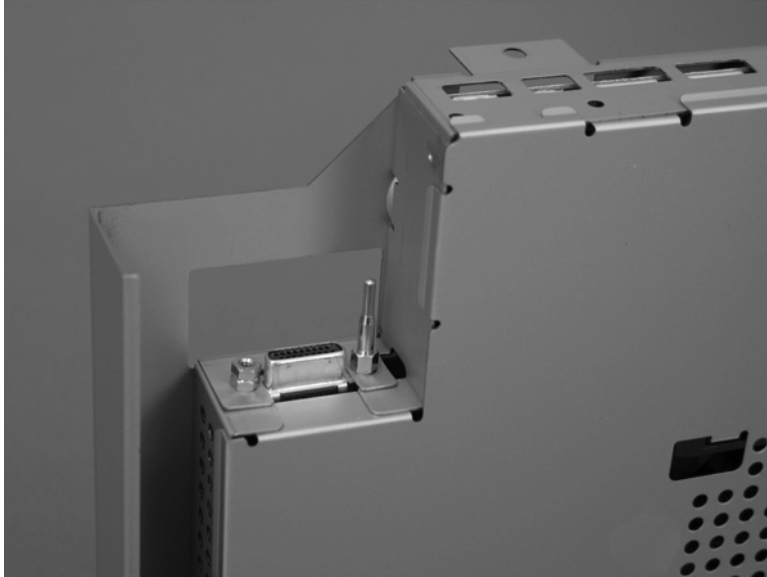

📝 NOTE: If you are installing a replacement SCB, transfer the ferrite core and bracket from the discarded SCB to the replacement assembly

💡 Reinstallation tip It might be easier to install the SCB if you remove the ferrite core from the bracket, and then position the SCB in the product.

Thread the FFC through the opening in the back of the bracket, through the ferrite core, and then snap the ferrite core into the bracket.

Scanner-control board (SCB; M575c)

Before proceeding, remove the following components:

- Rear-upper cover. See the product repair manual.

Remove the SCB

1. Release eight connectors (callout 1), two FFCs (callout 2), and then remove two screws (callout 3).

 **NOTE:** The scanner cable at the left-hand edge of the SCB is held in place with one thumbscrew screw.

Figure 1-197 Remove the SCB (1 of 2)



2. Partially pull the SCB out of the product, thread the FFCs through the ferrite cores to release them, and then remove the SCB.

Figure 1-198 Remove the SCB (2 of 2)

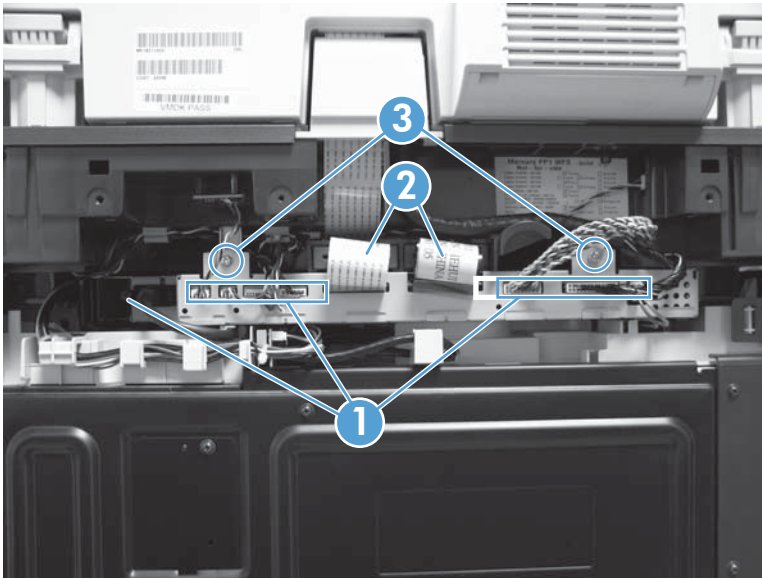
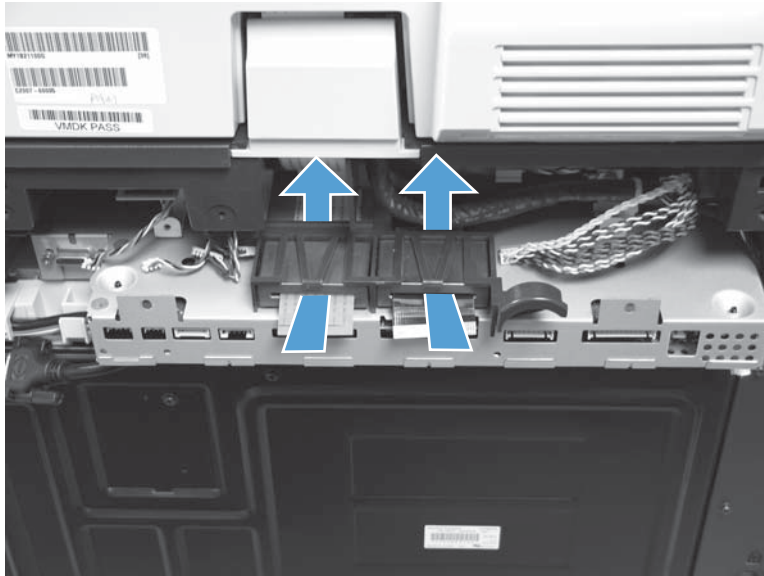

Reinstall the SCB

When reinstalling the SCB, note the locator pin for the scanner cable. It might be easier to install the scanner cable with a screw driver.

⚠ WARNING! Do not over tighten the screw when installing the cable. Over tightening the screw can cause the nut to shear off of the SCB cage.

Figure 1-199 Reinstalling the SCB

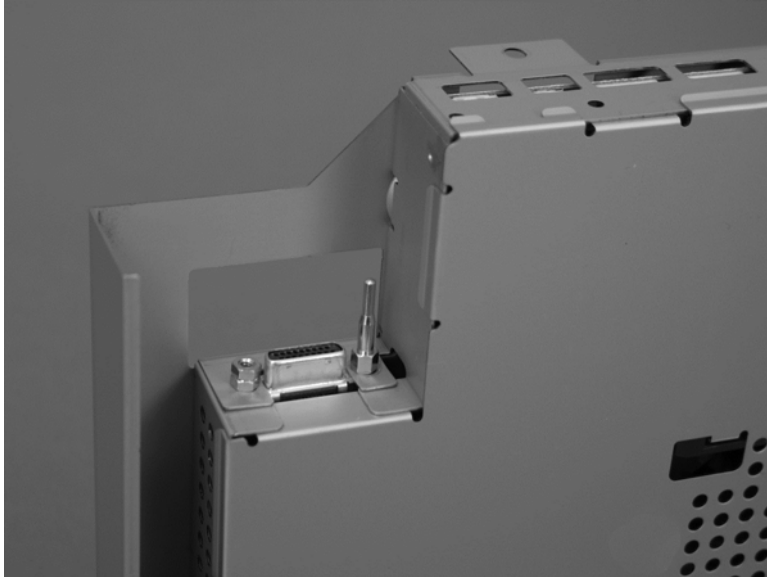

📝 NOTE: If you are installing a replacement SCB, transfer the ferrite cores and bracket from the discarded SCB to the replacement assembly

💡 Reinstallation tip It might be easier to install the SCB if you remove the ferrite cores from the bracket, and then position the SCB in the product.

Thread the FFCs through the openings in the back of the bracket, through the ferrite cores, and then snap the ferrite cores into the bracket.

Image scanner whole unit

Before proceeding, remove the following components:

- Stapler cover. See [Stapler cover on page 85](#).
- Rear-upper cover. See [Rear-upper cover on page 95](#).
- Left-upper cover. See [Left-upper cover on page 97](#).
- Document feeder whole unit.
 - See [Document feeder whole unit on page 127](#).
 - See [Document feeder whole unit \(M575c model\) on page 130](#).
- Scanner-control board (SCB).
 - See [Scanner-control board \(SCB\) on page 133](#).
 - See [Scanner-control board \(SCB; M575c\) on page 136](#).

Remove the scanner assembly

1. Remove two screws (callout 1).

Figure 1-200 Remove the scanner assembly (1 of 5)

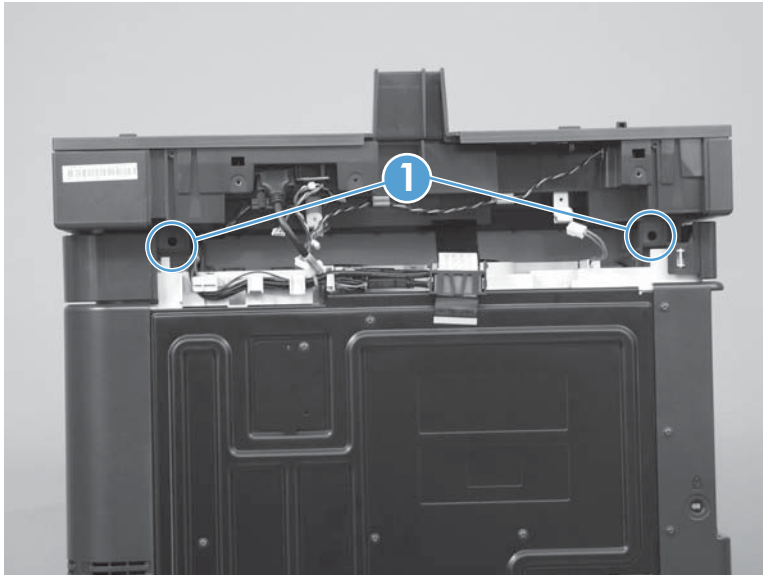

2. Remove one screw on the right side of the scanner.

Figure 1-201 Remove the scanner assembly (2 of 5)

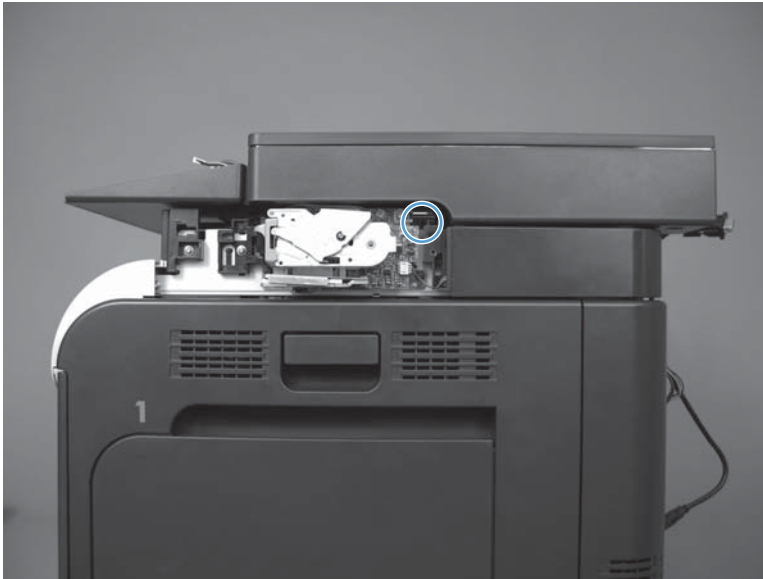

3. Remove one screw on the left side of the scanner.

Figure 1-202 Remove the scanner assembly (3 of 5)



4. Disconnect the control panel cable (callout 1) and the USB cable (callout 2). Release the cables from the retainers (callout 3).

Figure 1-203 Remove the scanner assembly (4 of 5)

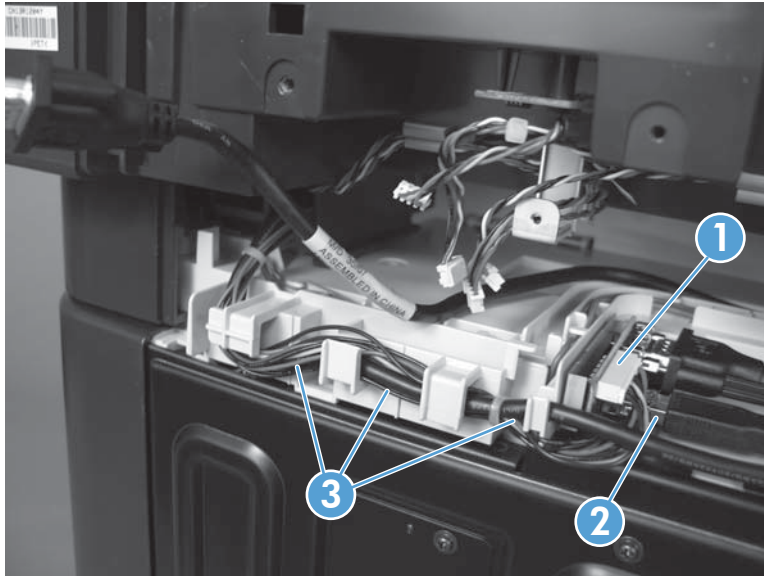

5. Slide the scanner toward the back of the product (callout 1) and then lift (callout 2) to remove it.

Figure 1-204 Remove the scanner assembly (5 of 5)

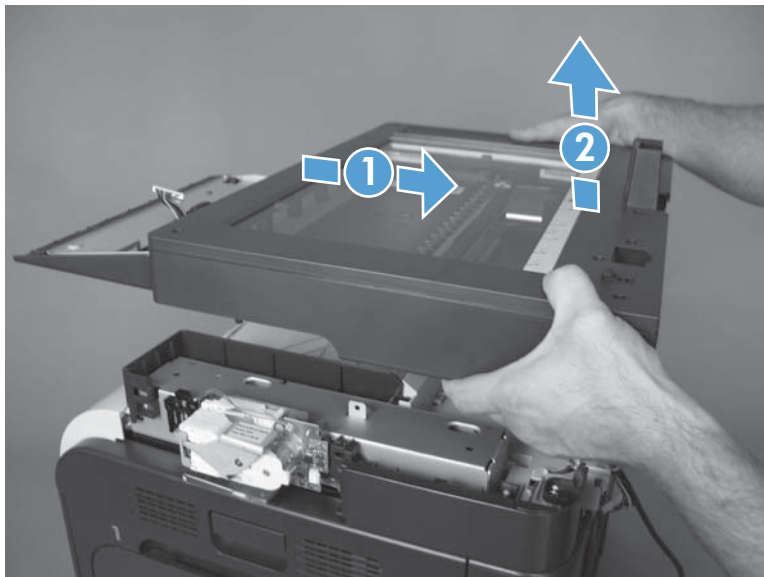

Reinstall the scanner

Transfer the control-panel cable to a replacement image scanner

If you are installing a replacement image scanner, remove the control panel cable from the discarded assembly and then install it on the replacement assembly.

1. Carefully turn the scanner assembly over to access the bottom of the assembly. Note the location of the control-panel cable tie (callout 1) in the slot at the control-panel end of the cable.

 **TIP:** When the cable is installed on the replacement scanner assembly, this cable tie must be correctly positioned so that the cable will be long enough to reconnect the control panel.

Figure 1-205 Transfer the control-panel cable (1 of 7)



2. Remove the control-panel cable and wire harness (callout 1) from the control-panel access hole (callout 2) and cable channel (callout 3).

Figure 1-206 Transfer the control-panel cable (2 of 7)

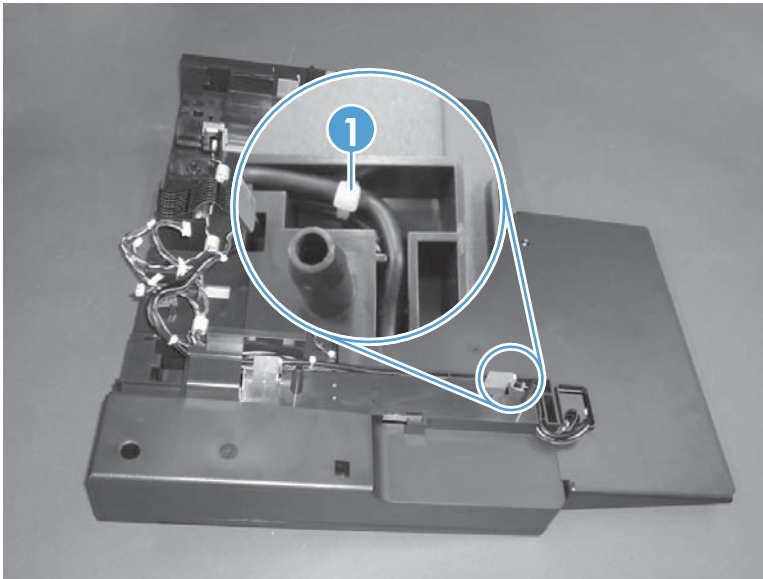
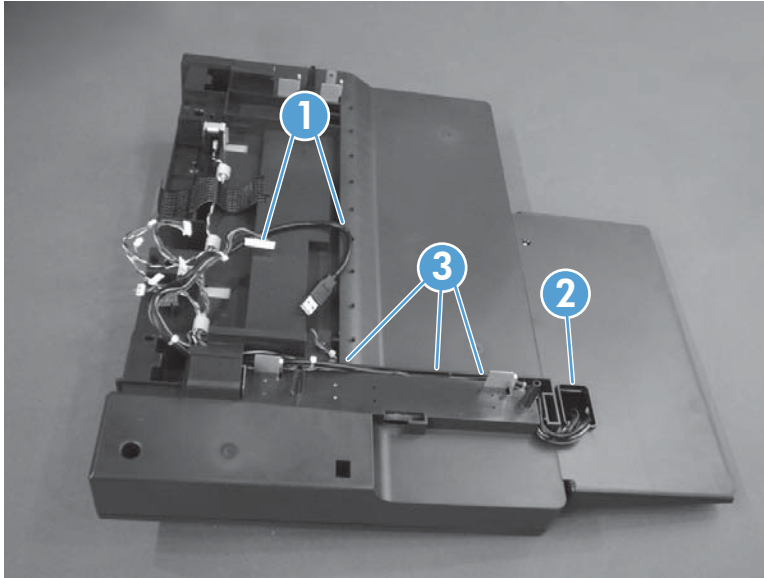

3. Feed the wire harness and cable through the raceway (callout 1) to remove them.

Figure 1-207 Transfer the control-panel cable (3 of 7)

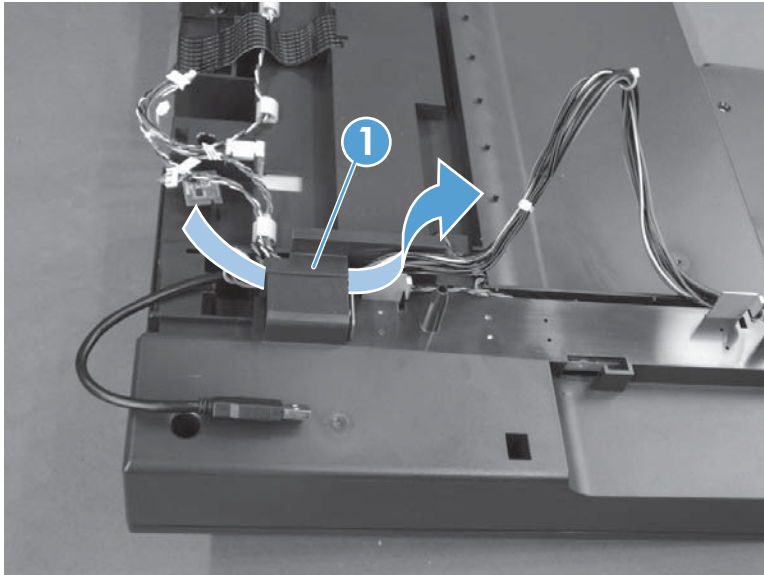

4. On the replacement scanner assembly, feed the control-panel cable and wire harness through the access hole (callout 1), and then lay the wire harness into the channel (callout 2).

Figure 1-208 Transfer the control-panel cable (4 of 7)

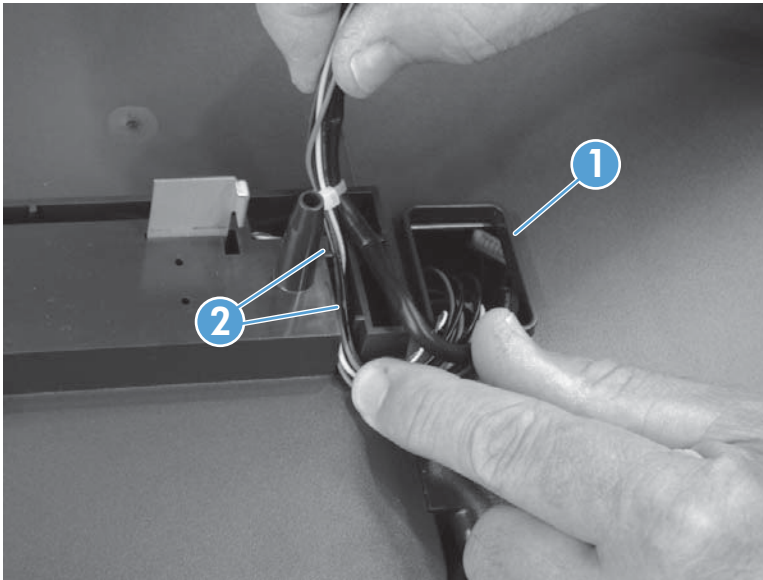

5. Carefully push the control-panel cable into the channel over the wire harness.

CAUTION: Make sure that the wire harness is fully seated into the channel before installing the cable. Do not pinch the wire-harness wires between the channel and the cable.

Figure 1-209 Transfer the control-panel cable (5 of 7)

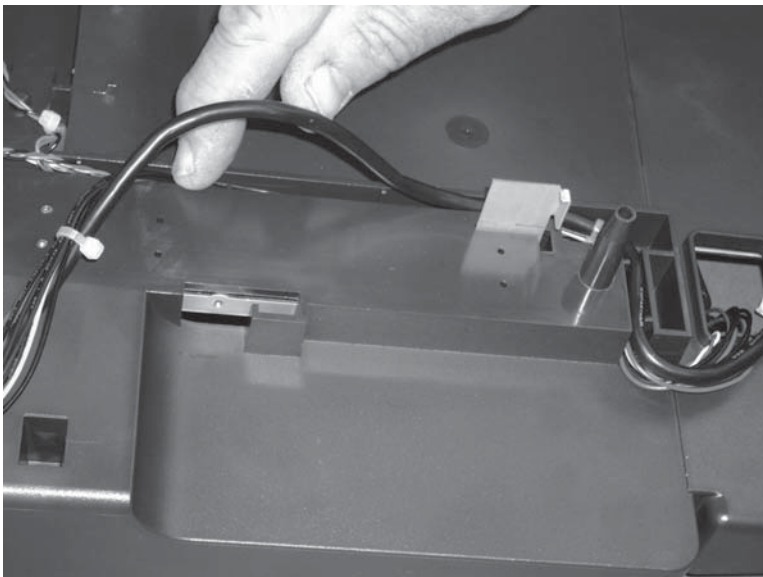

6. Feed the wire harness and cable through the raceway (callout 1).

Figure 1-210 Transfer the control-panel cable (6 of 7)

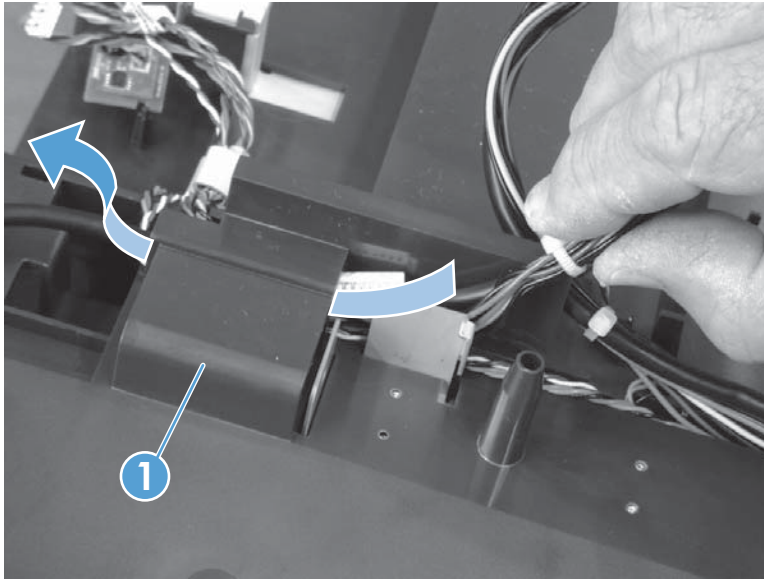

7. With the wire harness and cable installed, make sure that the wire harness and cable are completely installed and in the channel.

⚠ CAUTION: Do not pinch the wire-harness wires between the channel and the cable.

Figure 1-211 Transfer the control-panel cable (7 of 7)

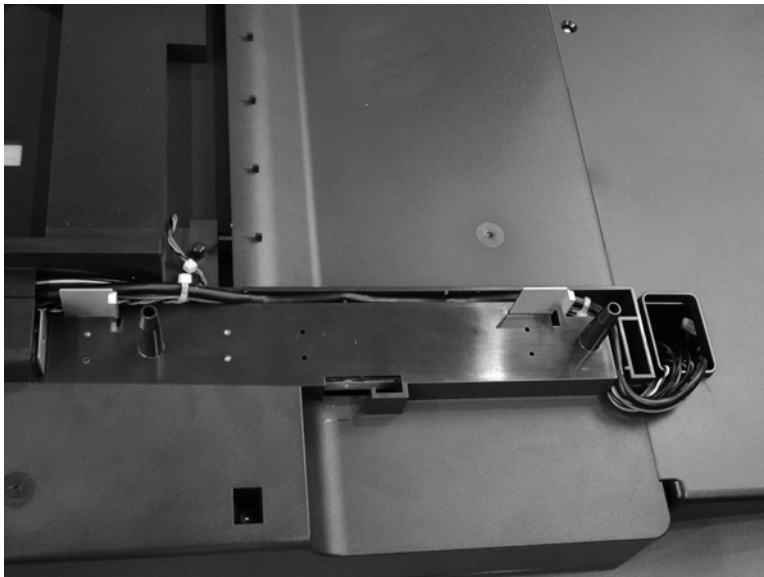

Install foam reflector kit (white backing) on the new document feeder

- ▲ If a replacement document feeder, image scanner, or both assemblies are installed, you must install a replacement foam reflector kit. See [Foam reflector kit on page 38](#).

Calibrate the scanner

1. On the control-panel Home screen, scroll to and touch [Device Maintenance](#).
2. Touch [Calibration/Cleaning](#).
3. Touch [Calibrate Scanner](#).
4. Follow the instructions on the control-panel display.

Internal assemblies

 **TIP:** For clarity, some photos in this chapter show components removed that would not be removed to service the product. If necessary, remove the components listed at the beginning of a procedure before proceeding to service the product.

Stapler assembly

Before proceeding, remove the following components:

- Stapler cover. See [Stapler cover on page 85](#).

Remove the stapler assembly

- ▲ Disconnect one connector (callout 1), remove two screws (callout 2), and then remove the stapler assembly.

Figure 1-212 Remove the stapler assembly

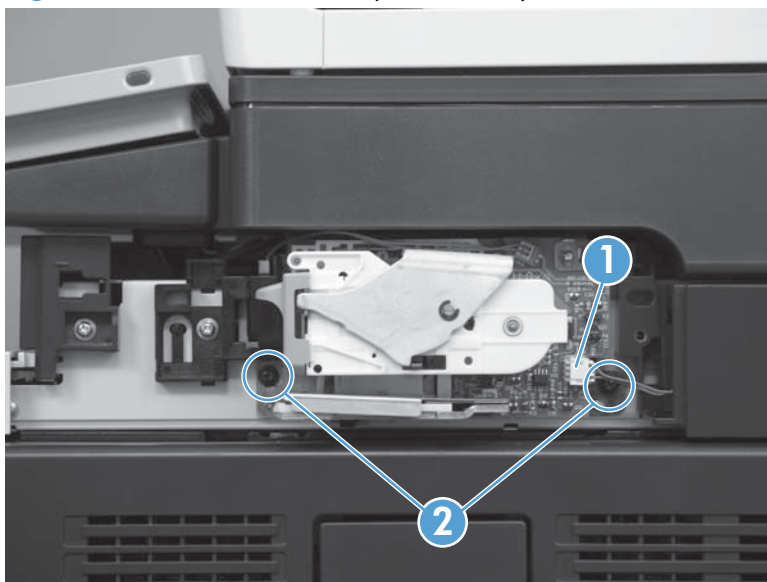

Interconnect board (ICB)

WARNING! Do not remove the ICB from a product and then install it into a **different** product. Failure to follow this warning will result in severe damage to that product and cause it to be unusable. HP recommends that if you remove and replace the ICB, you should destroy the discarded ICB so that it can not accidentally be installed in a different product.

Before proceeding, remove the following components:

- Toner-collection unit. See [Toner-collection unit on page 15](#).
- Formatter PCA. See [Formatter PCA on page 17](#).
- Right-rear cover. See [Right-rear cover on page 90](#).
- Left cover. See [Left cover on page 92](#).
- Rear-upper cover. See [Rear-upper cover on page 95](#).
- Rear cover. See [Rear cover on page 98](#).

Remove the ICB

NOTE: To locate DC controller connector locations, see [DC controller PCA on page 8](#).

1. Disconnect the scanner cable (callout 1), the USB cable (callout 2), and the control panel connector (callout 3).

Figure 1-213 Remove the ICB (1 of 3)

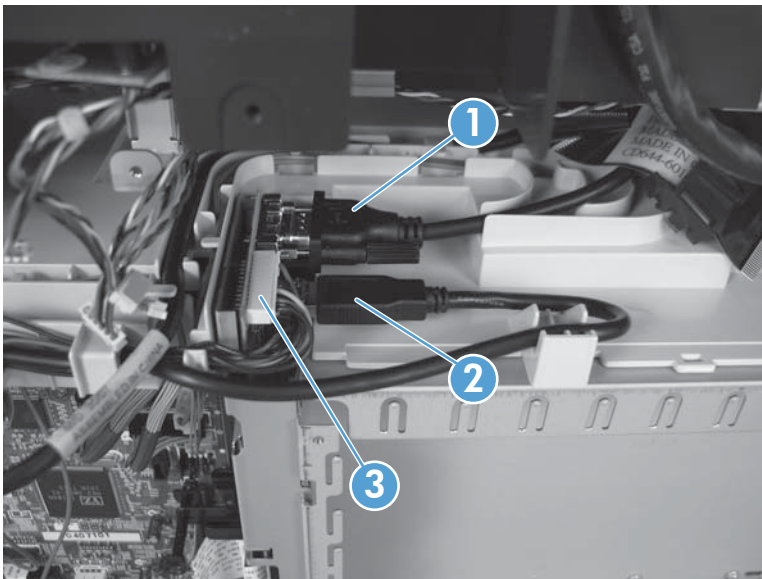

2. Remove one screw (callout 1) and disconnect one FFC (callout 2).

Figure 1-214 Remove the ICB (2 of 3)

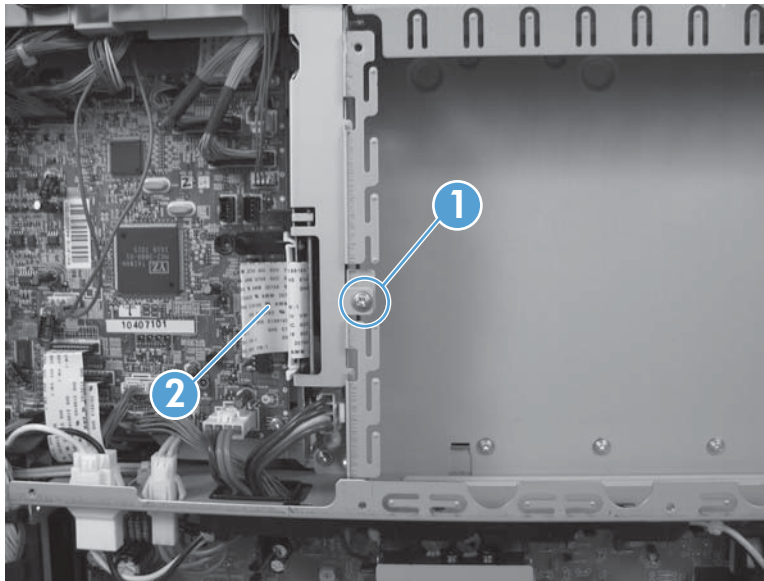

3. Slide the ICB up (callout 1), and then carefully rotate the ICB (callout 2). Disconnect one connector (callout 3) and remove the ICB.

Figure 1-215 Remove the ICB (3 of 3)

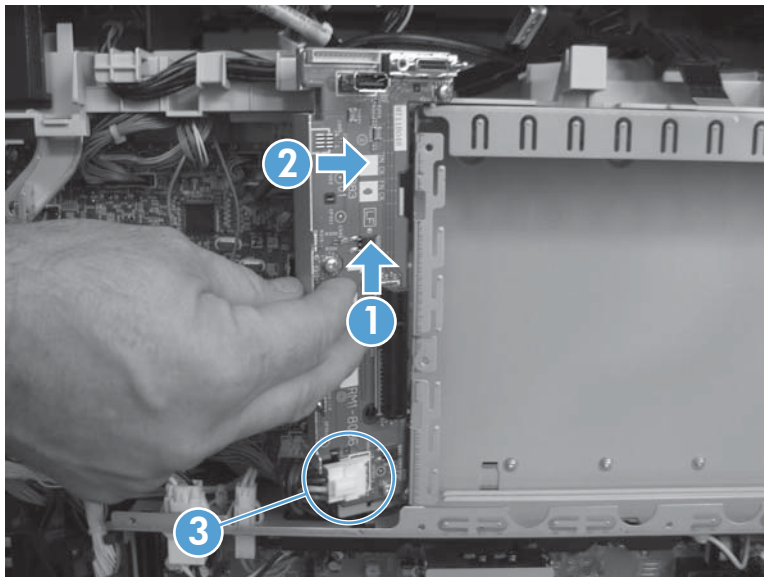

DC controller PCA and tray

Before proceeding, remove the following components:

- Toner-collection unit. See [Toner-collection unit on page 15](#).
- Formatter PCA. See [Formatter PCA on page 17](#).
- Right-rear cover. See [Right-rear cover on page 90](#).
- Left cover. See [Left cover on page 92](#).
- Rear-upper cover. See [Rear-upper cover on page 95](#).
- Rear cover. See [Rear cover on page 98](#).
- Interconnect board (ICB). See [Interconnect board \(ICB\) on page 148](#).

Remove the DC controller PCA and tray

CAUTION:  ESD-sensitive part.

TIP: To access components behind the DC controller PCA, remove the PCA and the sheet-metal tray together. Disconnect all of the connectors on the PCA, and then remove five screws and the bracket, see [Figure 1-216 Remove the DC controller PCA and tray \(1 of 4\) on page 150](#) and [Figure 1-219 Remove the DC controller PCA and tray \(4 of 4\) on page 152](#).

NOTE: To locate DC controller connector locations, see [DC controller PCA on page 8](#).

1. Remove one screw (callout 1), and then remove the sheet-metal bracket (callout 2).

Figure 1-216 Remove the DC controller PCA and tray (1 of 4)

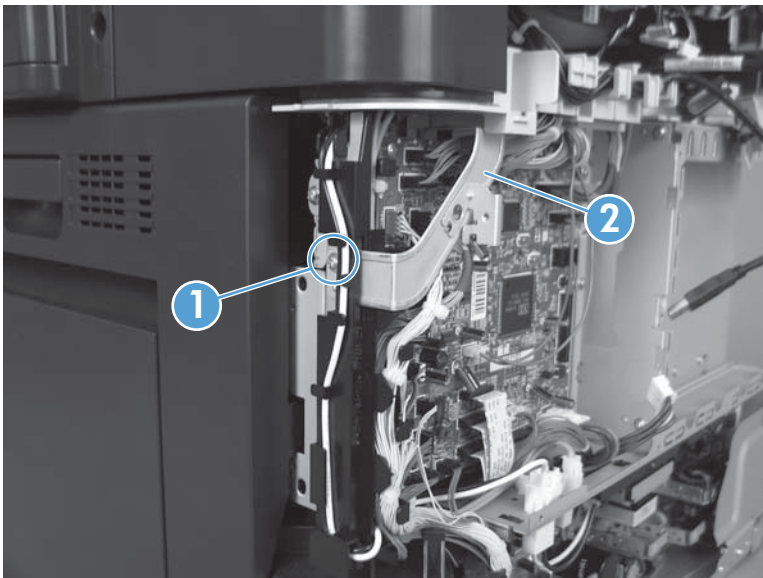

2. Disconnect all the connectors.

 **Reinstallation tip** The connector locations J133 and J134 are not used.

Figure 1-217 Remove the DC controller PCA and tray (2 of 4)



3. Remove four screws, and then remove the DC controller PCA.

 **NOTE:** If removing the PCA with the sheet metal tray, skip this step and go to step 4.

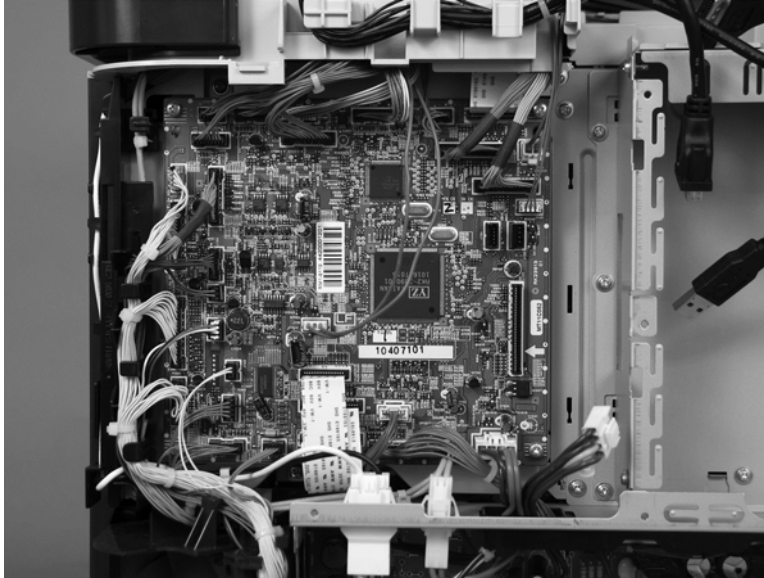
Figure 1-218 Remove the DC controller PCA and tray (3 of 4)



4. If necessary, remove three screws (callout 1) and the sheet metal tray.

 **NOTE:** Correctly install the cables in the cable guide (callout 2).

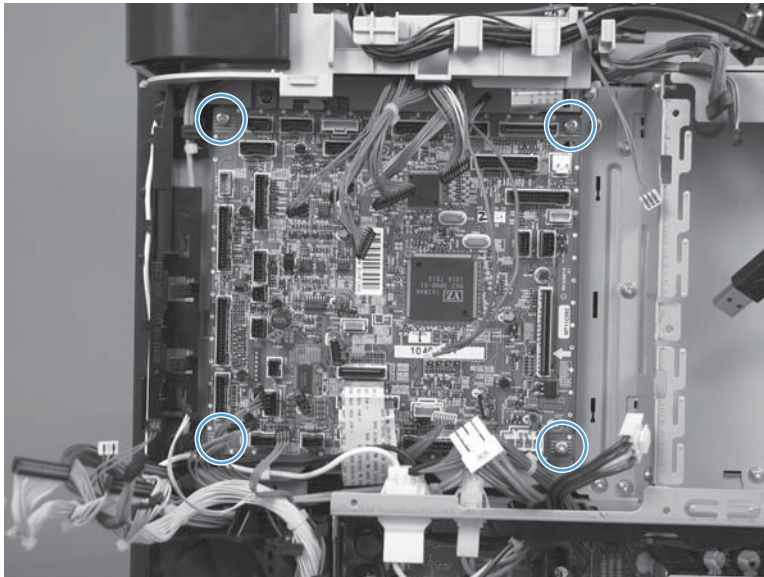
Figure 1-219 Remove the DC controller PCA and tray (4 of 4)



Low-voltage power supply (LVPS)

Before proceeding, remove the following components:

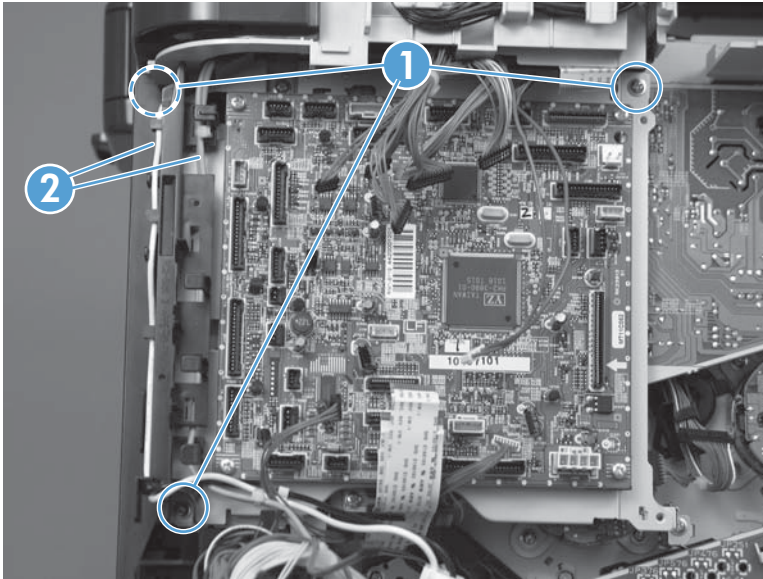
- Toner-collection unit. See [Toner-collection unit on page 15](#).
- Formatter PCA. See [Formatter PCA on page 17](#).
- Right-rear cover. See [Right-rear cover on page 90](#).
- Left cover. See [Left cover on page 92](#).
- Rear-upper cover. See [Rear-upper cover on page 95](#).
- Rear cover. See [Rear cover on page 98](#).
- Interconnect board (ICB). See [Interconnect board \(ICB\) on page 148](#).

 **NOTE:** If you are removing the power supply for internal product access, it is recommended that you leave the ICB installed on the power supply assembly.

Remove the LVPS

 **CAUTION:**  ESD-sensitive part.

 **NOTE:** The formatter cage is attached to the LVPS. Both components are removed as an assembly, and then the formatter cage is removed from the LVPS.

1. Disconnect six connectors (callout 1; J100, J101, J143 on the DC controller PCA).

 **NOTE:** To locate DC controller connector locations, see [DC controller PCA on page 8](#).

Figure 1-220 Remove the LVPS (1 of 8)



2. Push in on the locking tab to release the retainer (callout 2), and then separate the retainer from the assembly.

 **NOTE:** The retainer remains attached to the wire harness, and is disengaged from the assembly.

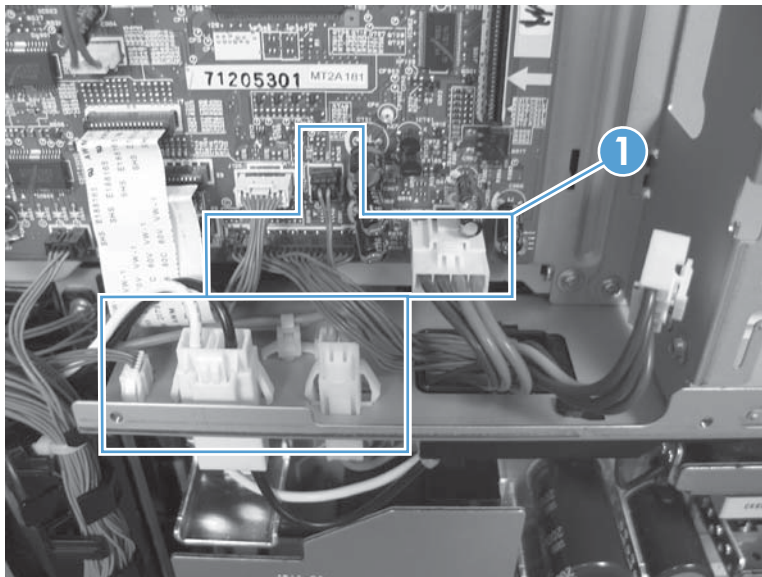
Figure 1-221 Remove the LVPS (2 of 8)



3. Remove three screws (callout 1), and then remove the handle (callout 2).

Figure 1-222 Remove the LVPS (3 of 8)

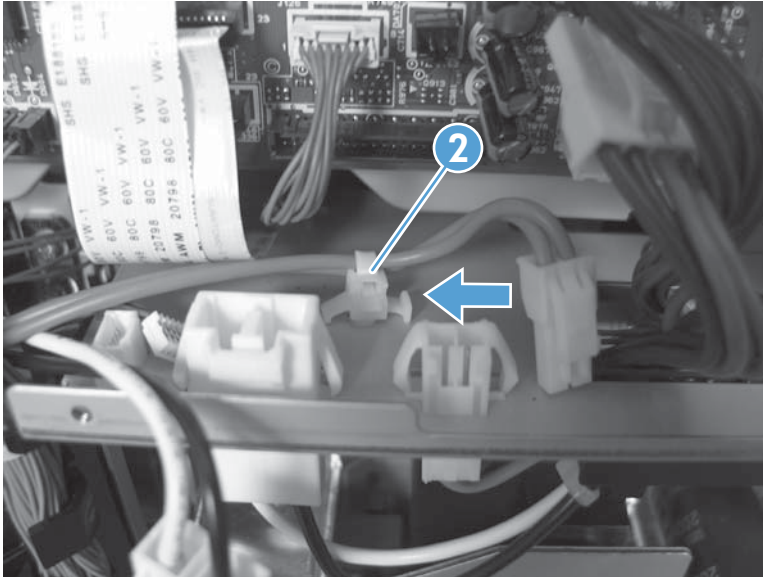
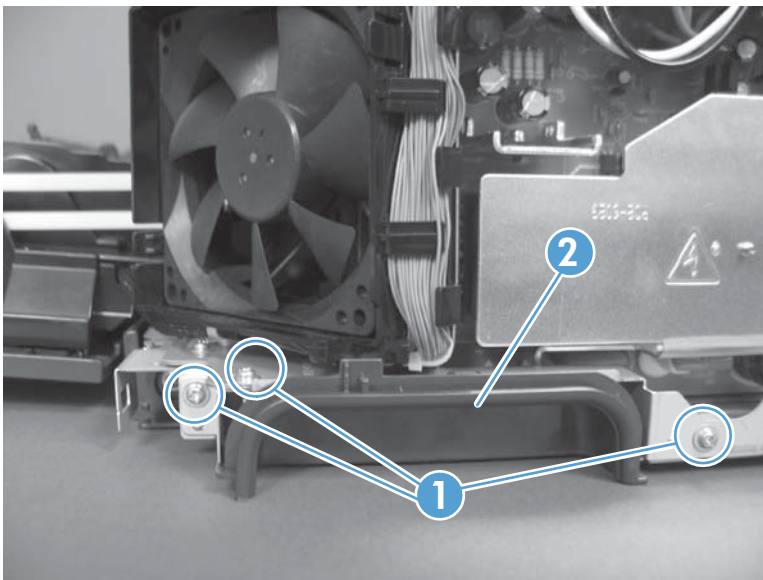

4. Remove five screws.

 **NOTE:** The illustration below shows the ICB removed.

Figure 1-223 Remove the LVPS (4 of 8)



5. Remove two screws.

Figure 1-224 Remove the LVPS (5 of 8)

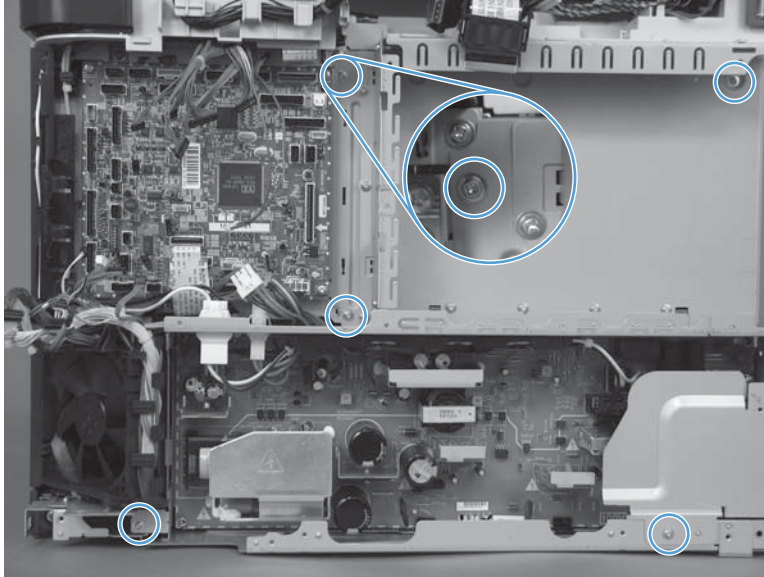
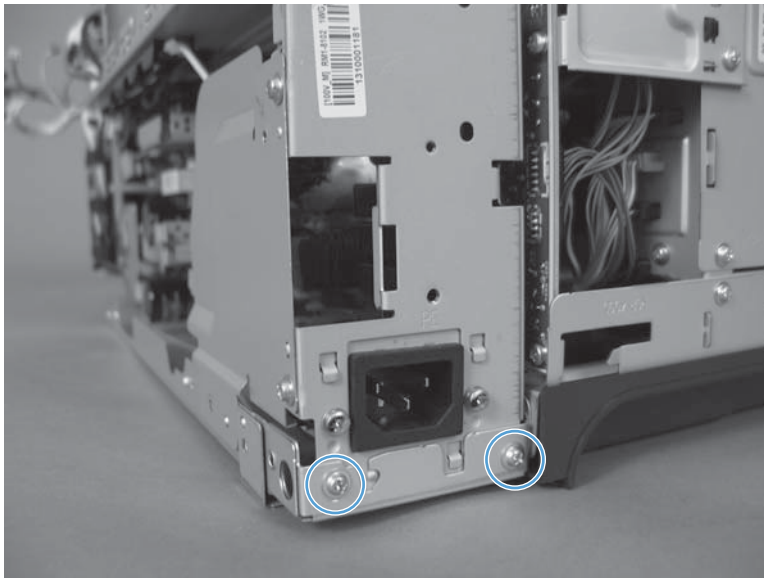

6. Rotate the formatter cage away from the top of the product.

Figure 1-225 Remove the LVPS (6 of 8)

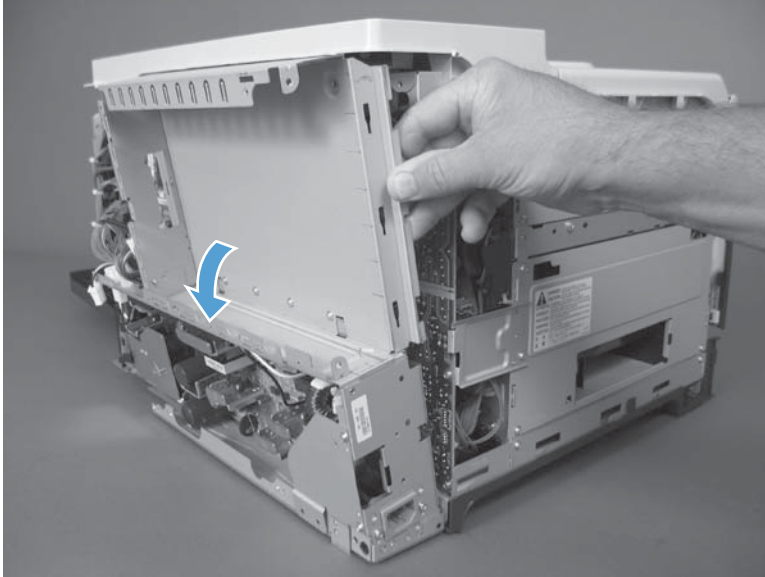

7. Remove the assembly.

Figure 1-226 Remove the LVPS (7 of 8)

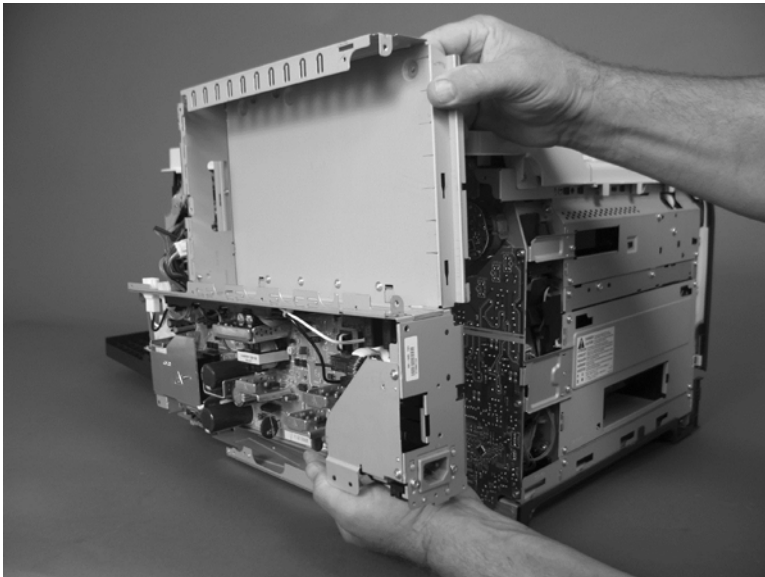

8. Remove four screws (callout 1), and then separate the formatter cage from the low-voltage power supply.

Figure 1-227 Remove the LVPS (8 of 8)

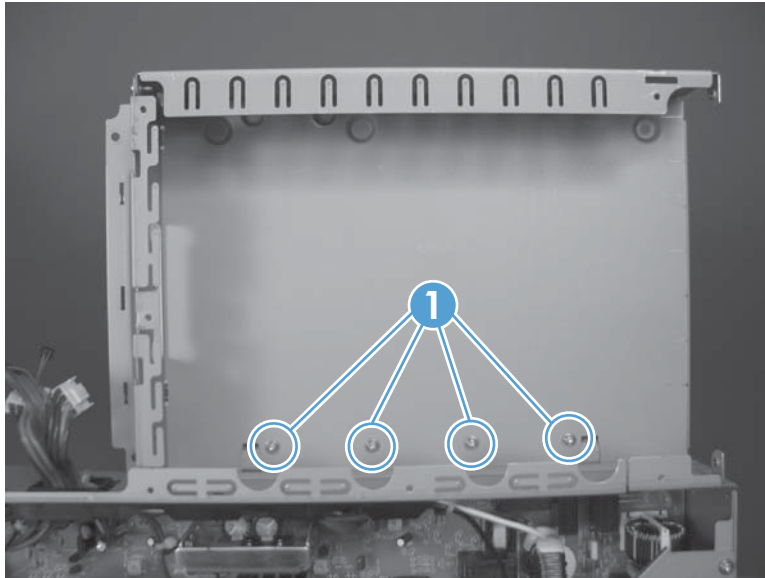

Delivery fan, cartridge fan, and environmental sensor

Before proceeding, remove the following components:

- Toner-collection unit. See [Toner-collection unit on page 15](#).
- Left cover. See [Left cover on page 92](#).

Remove the delivery fan, cartridge fan, and environmental sensor

1. Remove five screws (callout 1), and then remove the sheet-metal plate (callout 2).

 **NOTE:** Release the small sheet-metal plate (callout 3) to allow access to the larger sheet-metal plate behind it. Leave the smaller plate attached to the chassis.

Figure 1-228 Remove the delivery fan, cartridge fan, and environmental sensor (1 of 9)



2. Disconnect five connectors (callout 1).

 **NOTE:** Disconnect the larger connector on the right side from the bottom. Disconnect the two smaller connectors on the right side from the top.

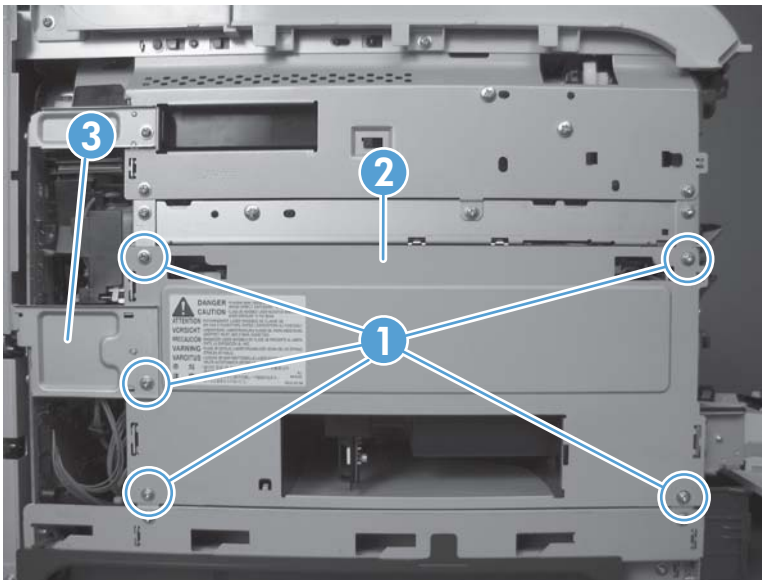
Figure 1-229 Remove the delivery fan, cartridge fan, and environmental sensor (2 of 9)



3. Release two tabs (callout 1), and then slide the delivery-fan and cartridge-fan assembly toward the power-supply side of the product to release it.

Figure 1-230 Remove the delivery fan, cartridge fan, and environmental sensor (3 of 9)

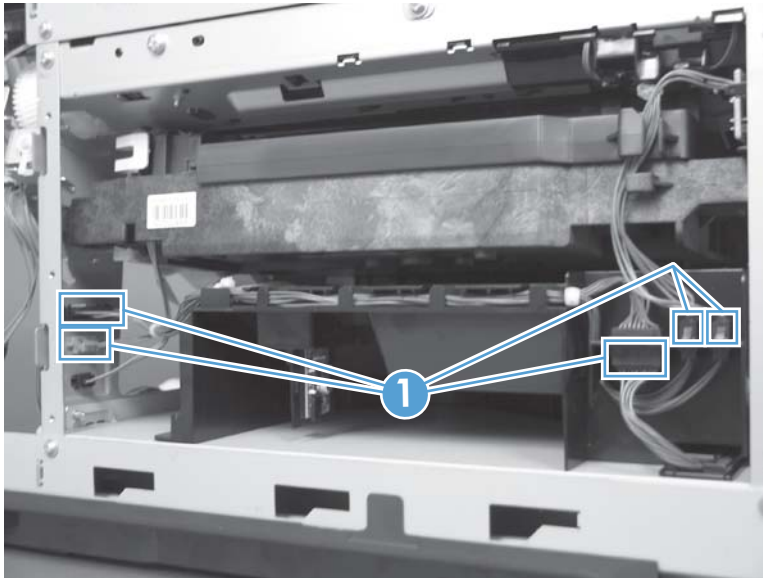
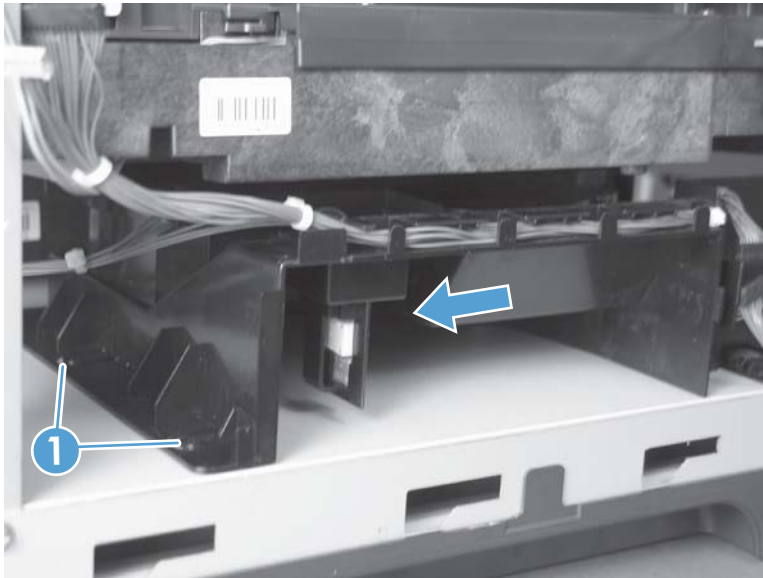

4. Pull the assembly slightly out of the product, disconnect two connectors (callout 1), and then remove the assembly.

Figure 1-231 Remove the delivery fan, cartridge fan, and environmental sensor (4 of 9)

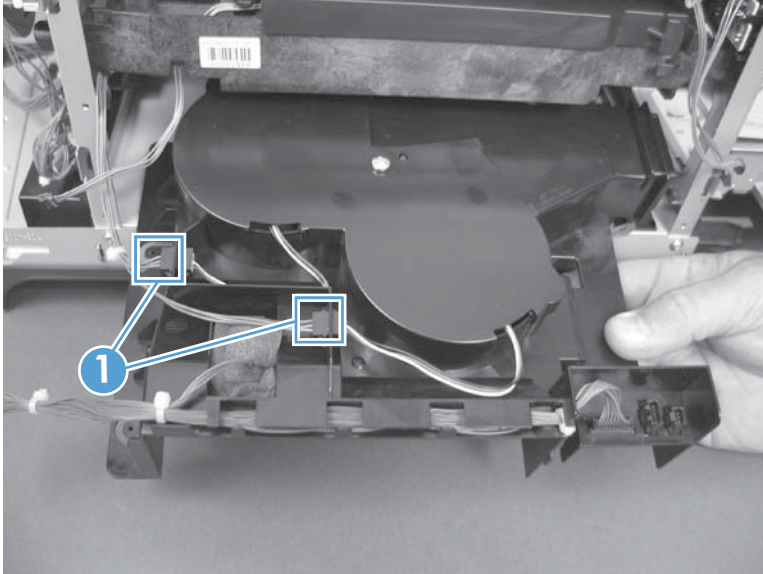

5. Remove one screw (callout 1), and then remove the cover (callout 2).

Figure 1-232 Remove the delivery fan, cartridge fan, and environmental sensor (5 of 9)

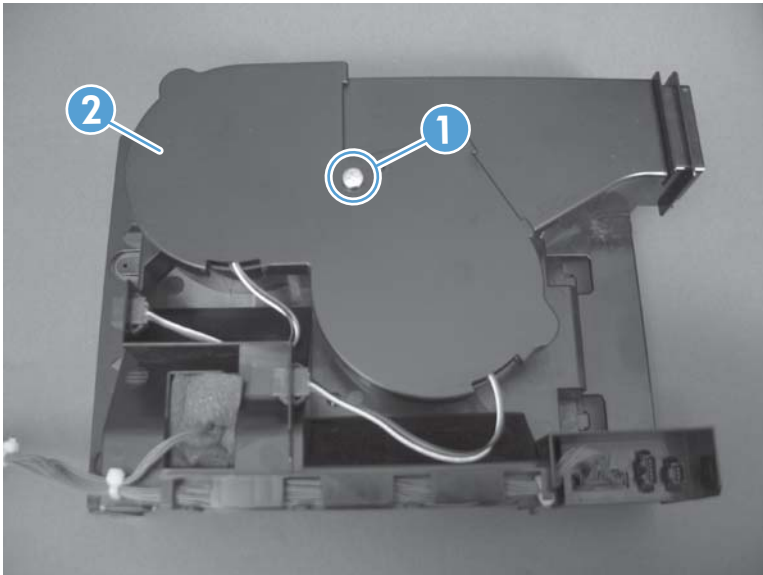

6. Disconnect two connectors (callout 1), and then remove the fans (callout 2).

Figure 1-233 Remove the delivery fan, cartridge fan, and environmental sensor (6 of 9)

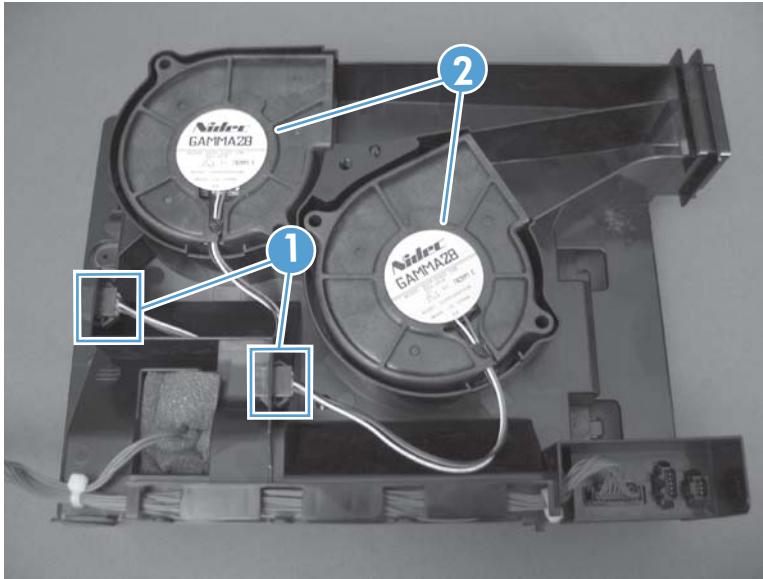

7. Remove the antistatic foam (callout 1).

Figure 1-234 Remove the delivery fan, cartridge fan, and environmental sensor (7 of 9)

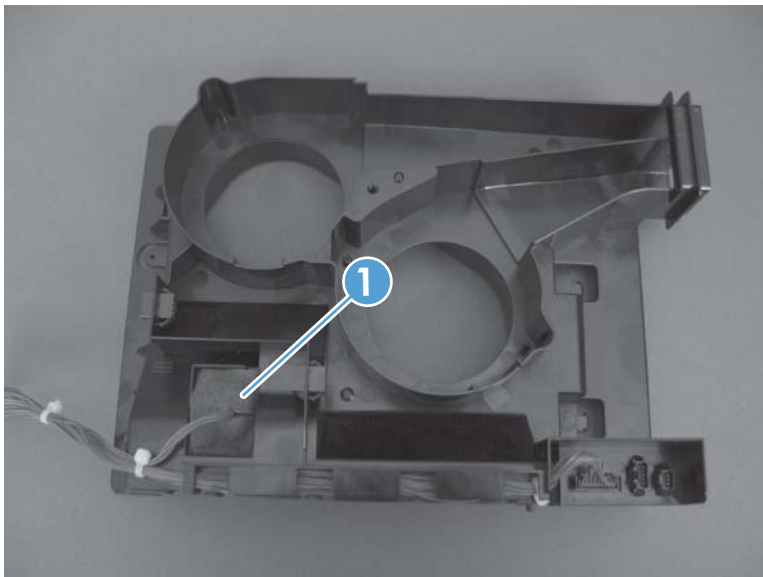

8. Release one tab (callout 1).

Figure 1-235 Remove the delivery fan, cartridge fan, and environmental sensor (8 of 9)

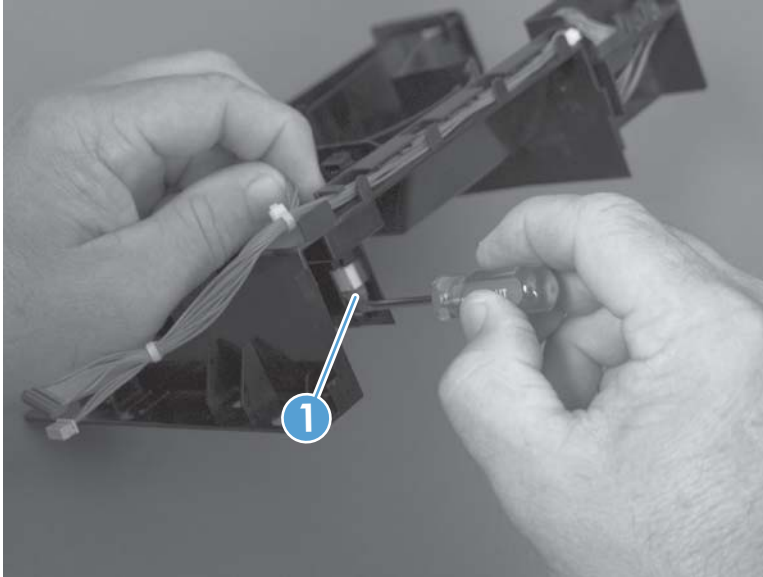

9. Disconnect one connector (callout 1), and then remove the environmental sensor.

CAUTION:  ESD-sensitive part.

Figure 1-236 Remove the delivery fan, cartridge fan, and environmental sensor (9 of 9)

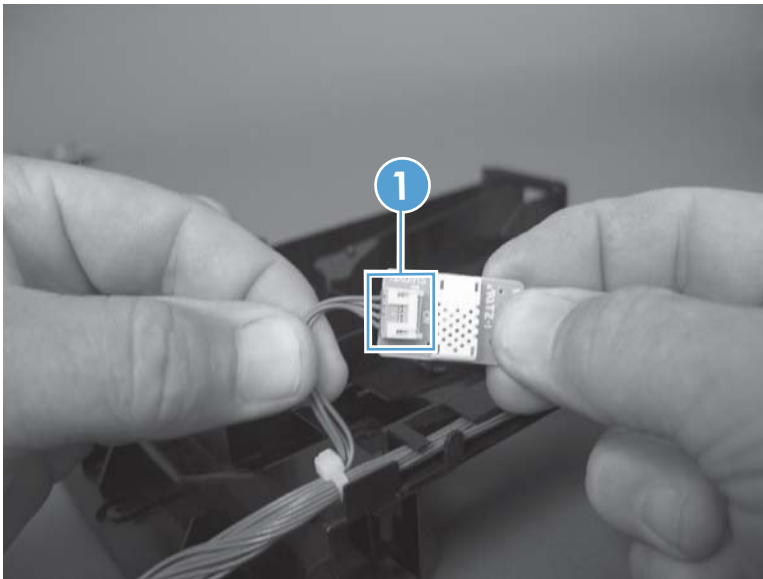

Toner-collection sensor

Before proceeding, remove the following components:

- Toner-collection unit. See [Toner-collection unit on page 15](#).
- Left cover. See [Left cover on page 92](#).

Remove the toner-collection sensor

1. Remove five screws (callout 1), and then remove the sheet-metal plate (callout 2).

 **NOTE:** Release the small sheet-metal plate (callout 3) to allow access to the larger sheet-metal plate behind it. Leave the smaller plate attached to the chassis.

Figure 1-237 Remove the toner-collection sensor (1 of 4)



2. Disconnect one connector (callout 1).

Figure 1-238 Remove the toner-collection sensor (2 of 4)

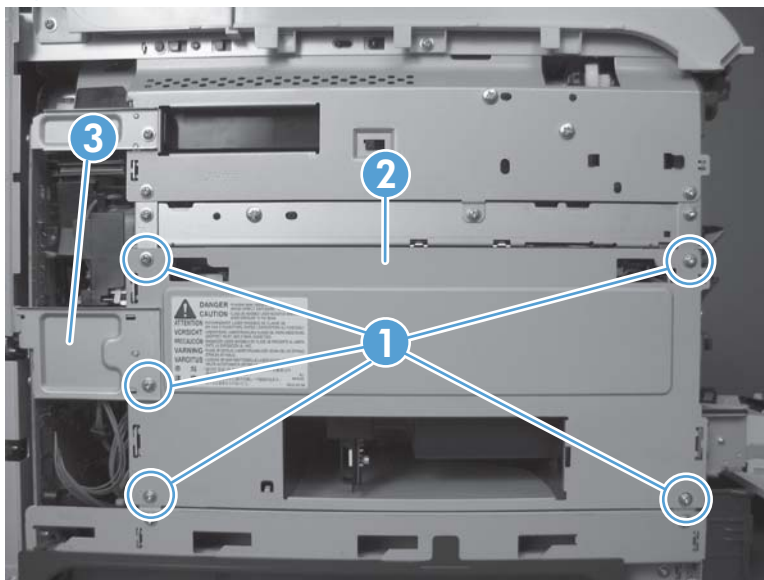
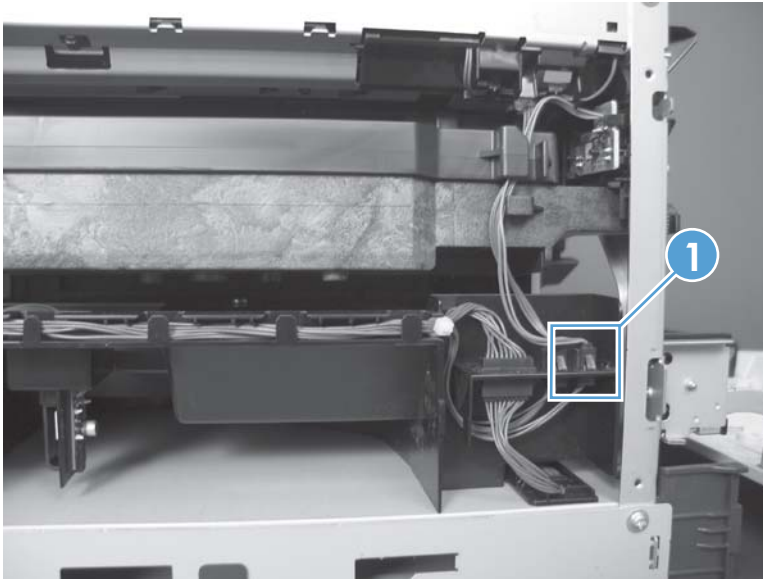

3. Remove one screw (callout 1).

 **Reinstallation tip** When you reinstall the sensor, make sure that the tab (callout 2) on the sensor body completely engages the slot in the product chassis.

Figure 1-239 Remove the toner-collection sensor (3 of 4)



4. Remove the toner-collection sensor.

Figure 1-240 Remove the toner-collection sensor (4 of 4)

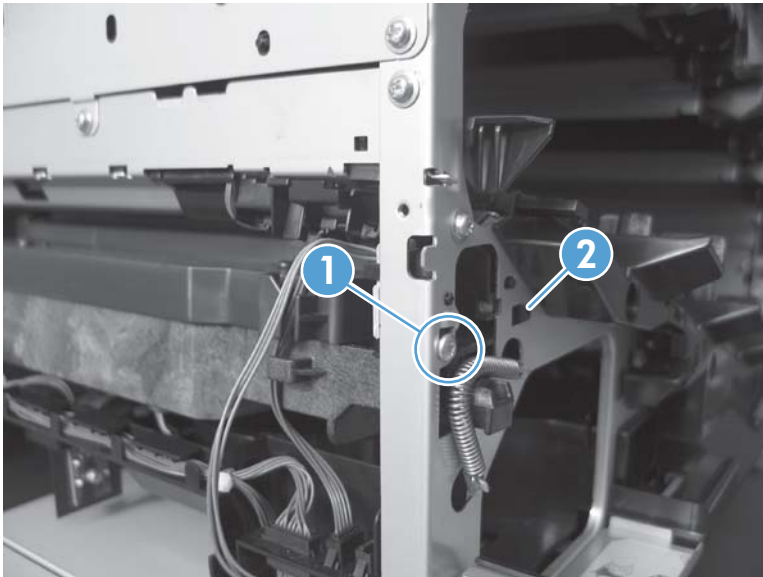

Residual-toner-feed motor

Before proceeding, remove the following components:

- Toner-collection unit. See [Toner-collection unit on page 15](#).
- Intermediate transfer belt (ITB). See [Intermediate transfer belt \(ITB\) on page 34](#).
- Left cover. See [Left cover on page 92](#).

Remove the residual-toner-feed motor

 **NOTE:** Be careful. Do not dislodge the residual-toner collection door when you remove the assembly. If the door becomes dislodged, see [Reinstall the residual-toner collection door on page 170](#) to reinstall it.

1. Release one tab (callout 1) while you support the cover (callout 2).

Figure 1-241 Remove the residual-toner-feed motor (1 of 7)

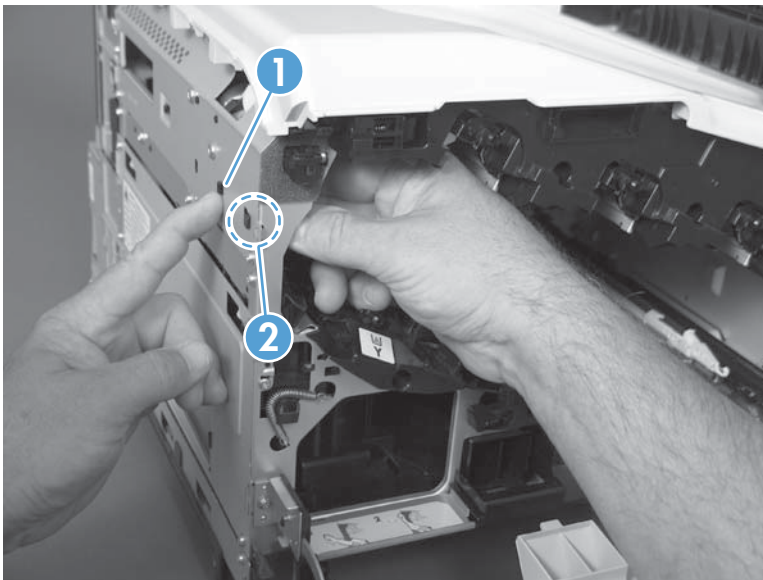

2. Remove the cover.

Figure 1-242 Remove the residual-toner-feed motor (2 of 7)



3. Disconnect one connector (callout 1).

Figure 1-243 Remove the residual-toner-feed motor (3 of 7)

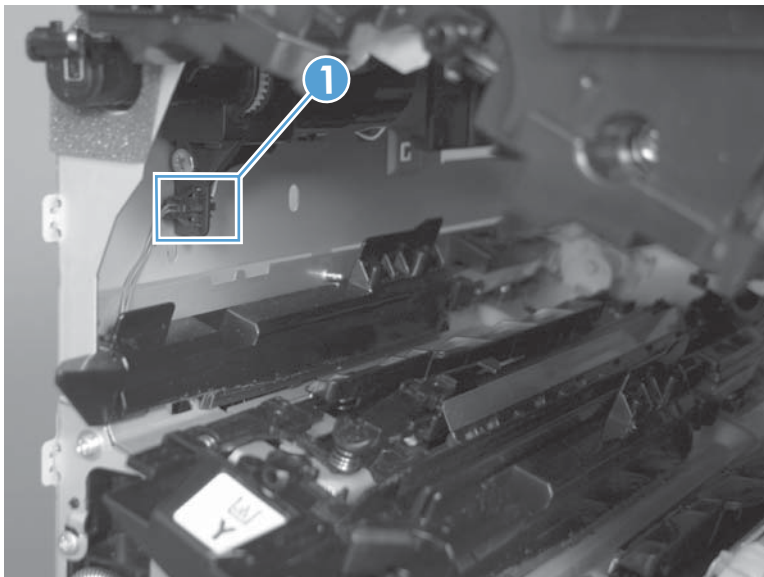

4. Support the assembly, and then remove two screws (callout 1).

Figure 1-244 Remove the residual-toner-feed motor (4 of 7)

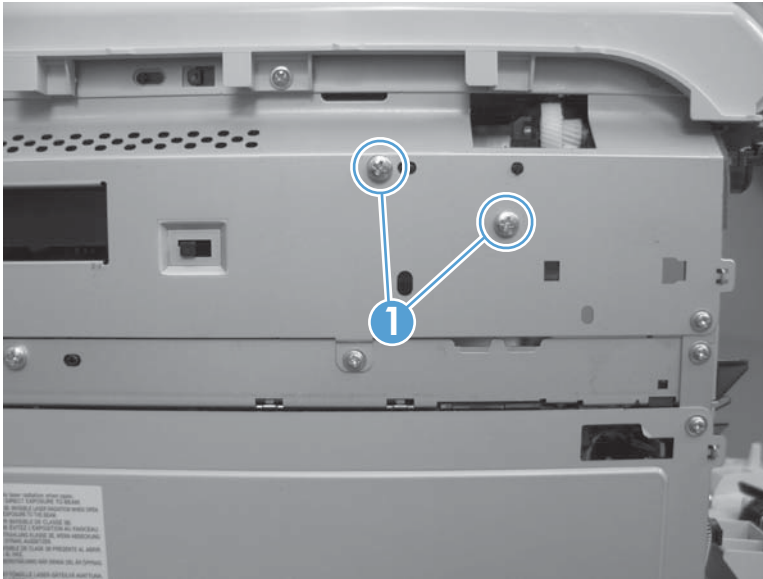

5. Be careful. Do not dislodge the residual-toner collection door when you remove the assembly. If the door becomes dislodged, see [Reinstall the residual-toner collection door on page 170](#) to reinstall it.

Figure 1-245 Remove the residual-toner-feed motor (5 of 7)

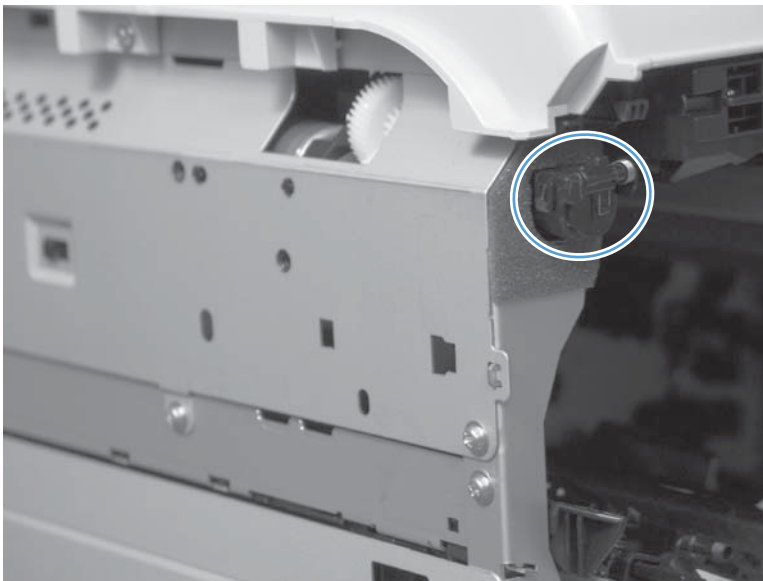

6. Push the assembly into the product to release it.

Figure 1-246 Remove the residual-toner-feed motor (6 of 7)

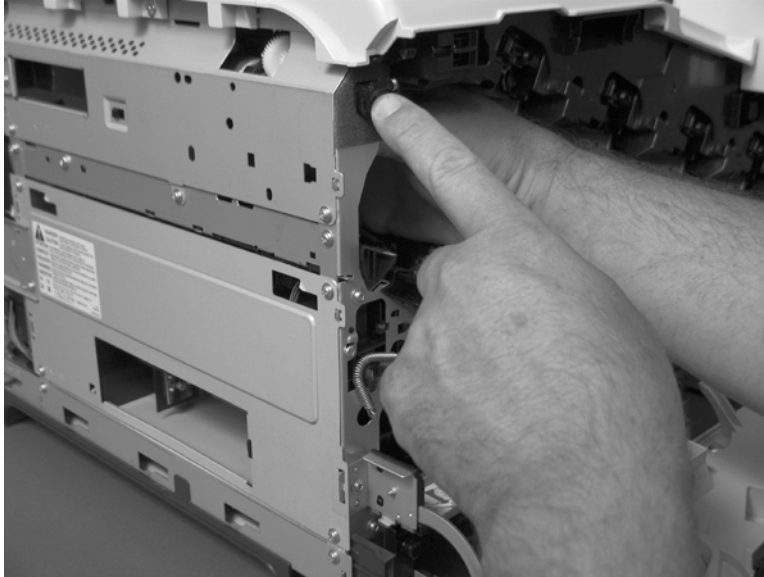

7. Remove the motor.

Figure 1-247 Remove the residual-toner-feed motor (7 of 7)



Reinstall the residual-toner collection door

Snap the residual-toner collection door into the holders on the assembly. Make sure that the spring is correctly installed.

Figure 1-248 Reinstall the residual-toner collection door



Secondary transfer assembly

The secondary transfer assembly includes the transfer roller.

1. Open the right-door assembly.
2. Use the blue lever (callout 1) to lower the secondary transfer assembly.

Figure 1-249 Remove the transfer roller (1 of 3)

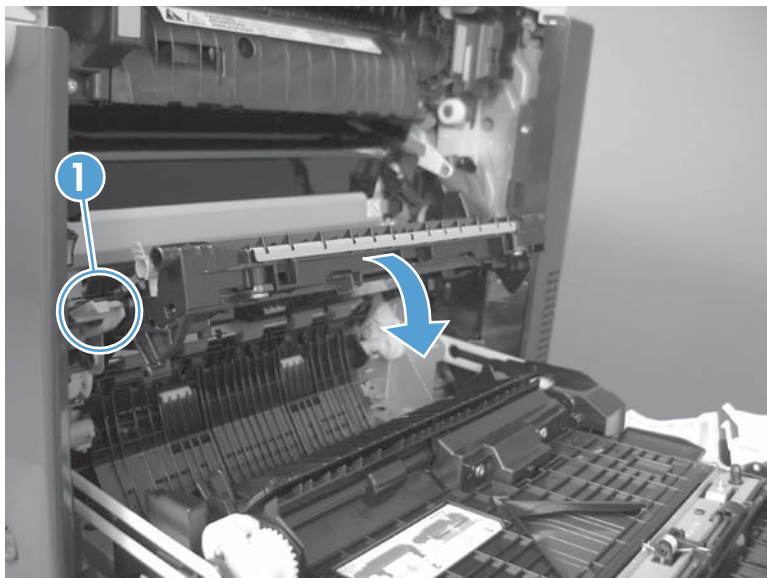

3. Release one tab and carefully remove the stopper.

 **NOTE:** You might have to slightly lift up on the corner of the assembly to release the stopper pin from the hole in the chassis.

Figure 1-250 Remove the secondary transfer assembly (2 of 3)



4. Remove the secondary transfer assembly.

Figure 1-251 Remove the secondary transfer assembly (3 of 3)

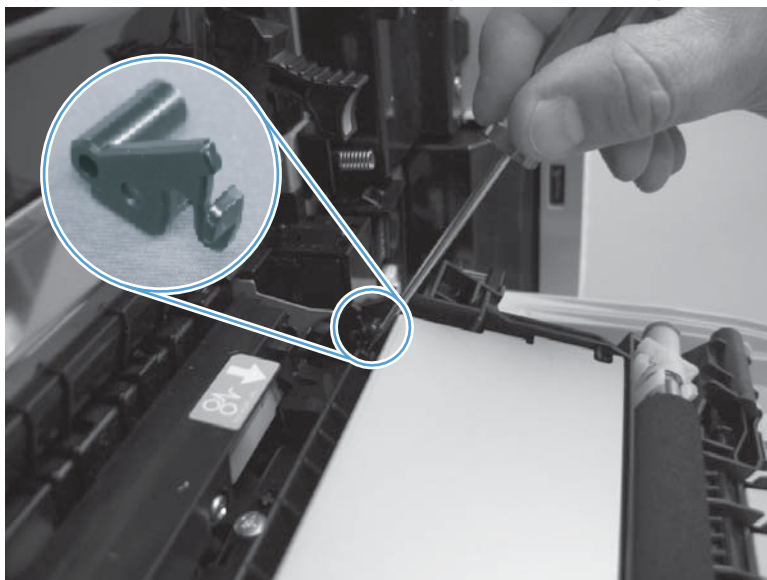

Reinstall the secondary transfer assembly

Press and hold down the blue release lever when you reinstall the assembly.

Figure 1-252 Reinstall the secondary transfer assembly

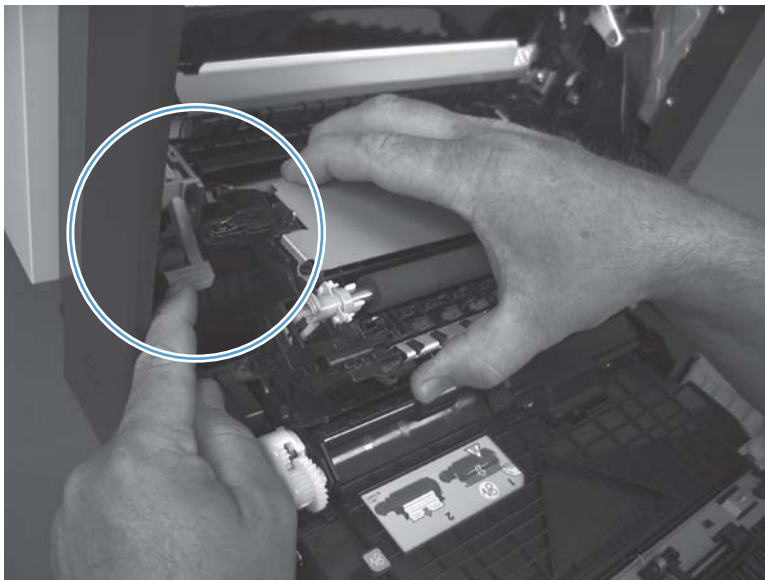

Lower pickup guide

Remove the lower pickup guide

1. Open the right-door assembly.
2. Locate the lower pickup guide directly below the registration assembly. The guide is locked into place by two green circular knobs (callout 1).

Figure 1-253 Remove the lower pickup guide (1 of 4)

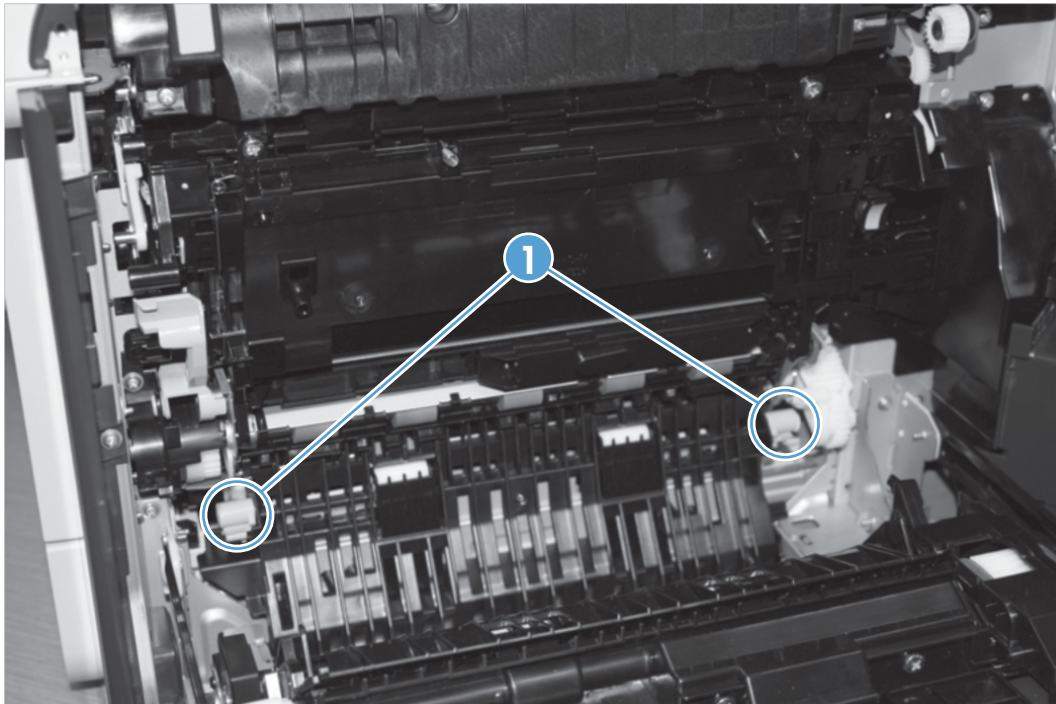

3. Lift the green circular knobs simultaneously to release the assembly.

Figure 1-254 Remove the lower pickup guide (2 of 4)

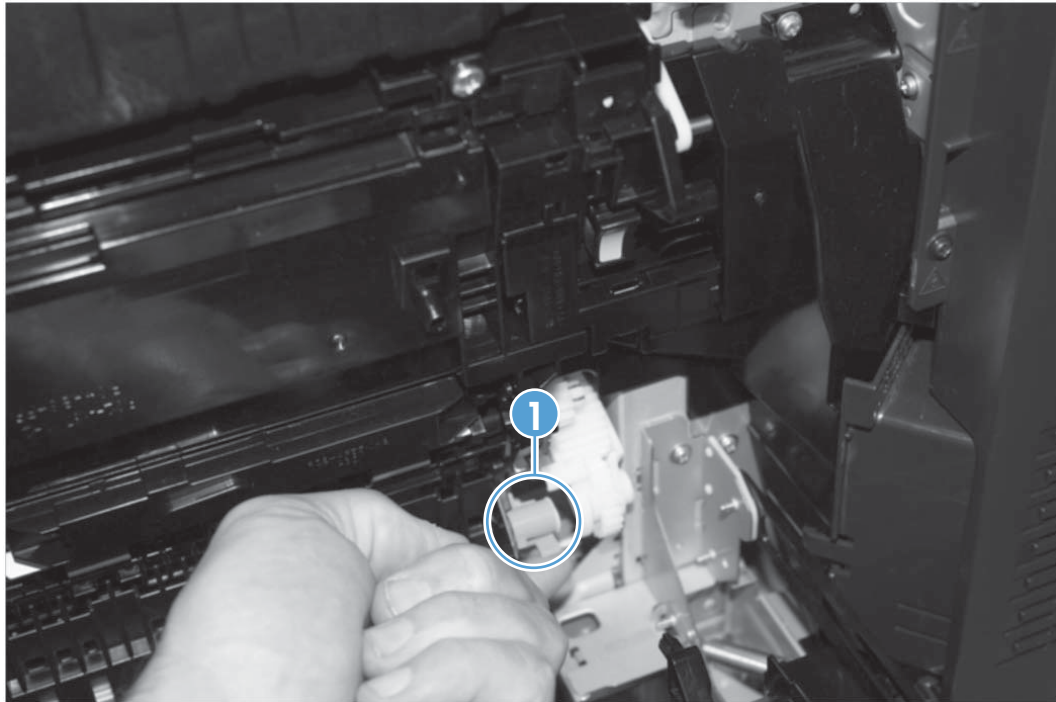

4. Raise the guide, and then loosen, but do not remove, one screw (callout 1) on the paper entrance guide.

Figure 1-255 Remove the lower pickup guide (3 of 4)

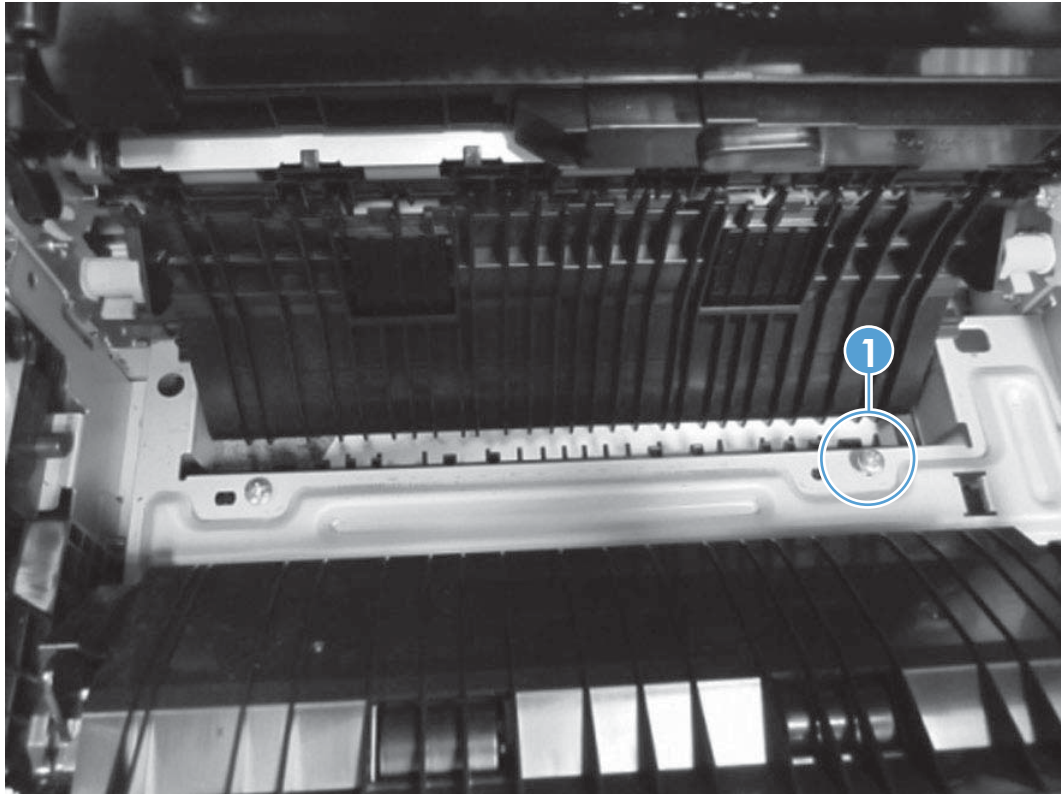

5. While pushing down on the paper entrance guide (callout 1), use a flat blade screwdriver to press in on the hinge pin (callout 2) and release it from the product. Rotate the assembly counterclockwise away from the product to remove it.

Figure 1-256 Remove the lower pickup guide (4 of 4)

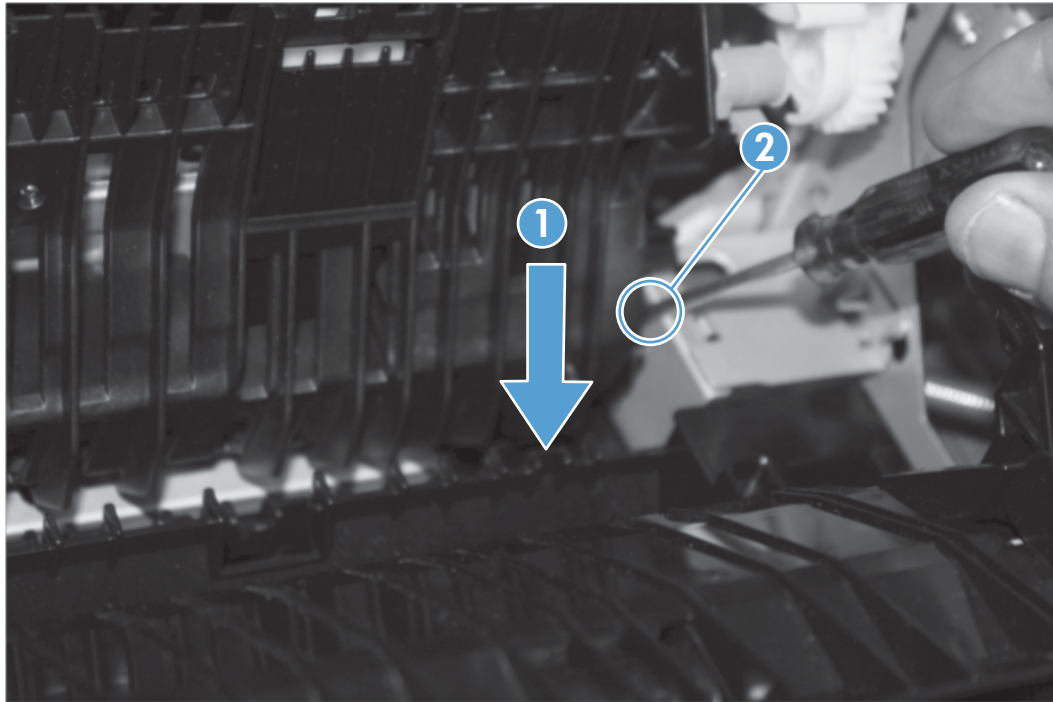

Reinstall the lower pickup guide

- ▲ Insert the front pin of the assembly into the hole at the front of the chassis. Slightly press down on the rear hinge pin and insert it into the hole at the rear of the chassis. Rotate the guide toward the product until the green knobs snap back into place. Tighten the screw on the paper entrance guide.

Registration density (RD) sensor assembly

Before proceeding, remove the following components:

- Intermediate transfer belt (ITB). See [Intermediate transfer belt \(ITB\) on page 34](#).
- Secondary transfer assembly. See [Secondary transfer assembly on page 171](#).

Remove the RD sensor assembly

1. Remove two screws (callout 1).

Figure 1-257 Remove the RD sensor assembly (1 of 6)

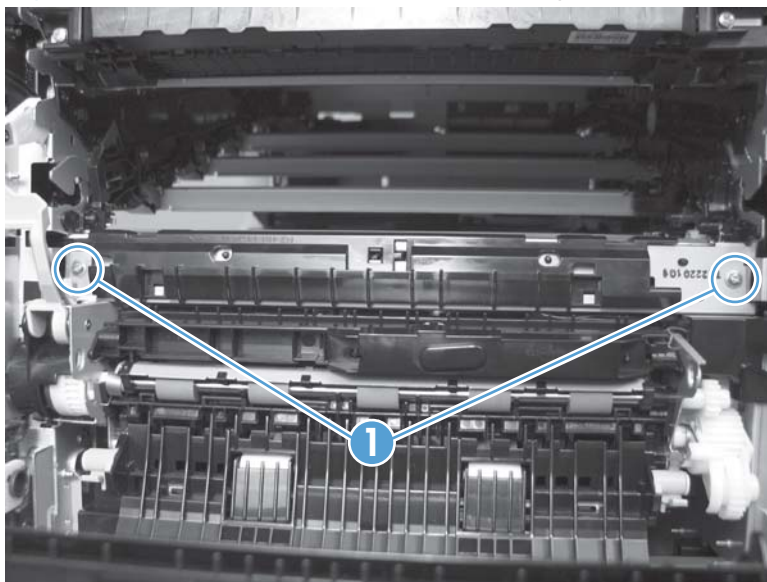

2. Slide the shutter toward the right side of the product. Keep the shutter in this position for the following step.

Figure 1-258 Remove the RD sensor assembly (2 of 6)

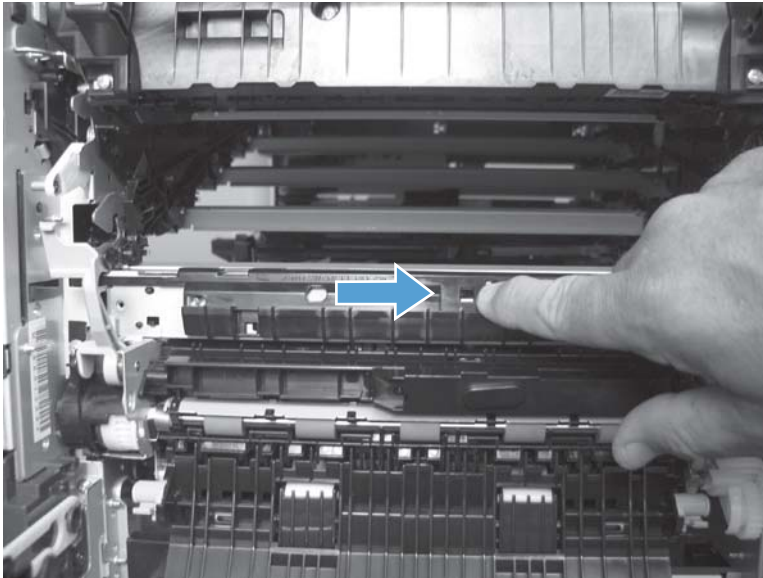

3. Carefully separate the assembly from the product. The assembly wire harnesses are still attached to the product.

CAUTION: Do not damage the shutter as it passes through the chassis.

Figure 1-259 Remove the RD sensor assembly (3 of 6)

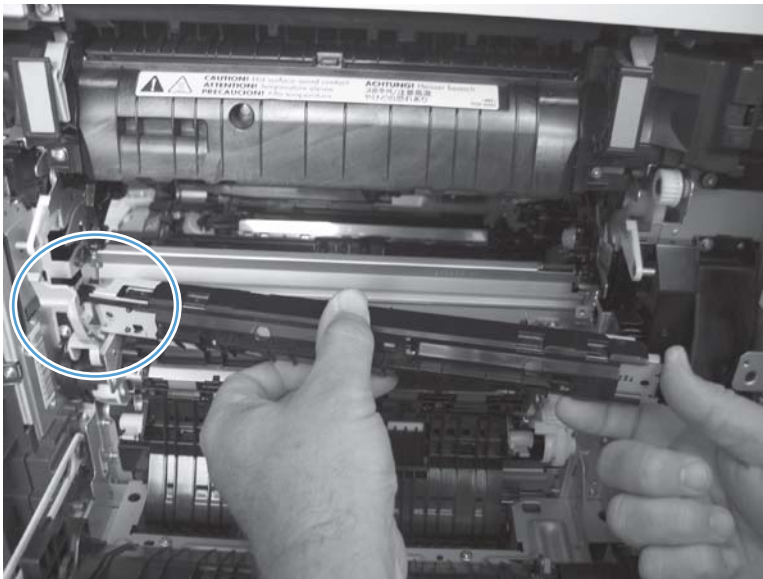

4. Disconnect two connectors (callout 1) on the back side of the assembly.

Figure 1-260 Remove the RD sensor assembly (4 of 6)

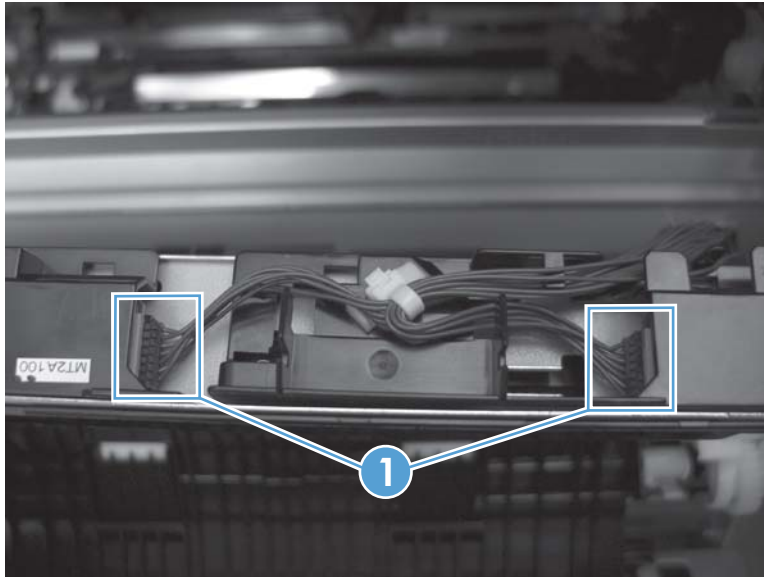

5. Push in on the locking tab to release the retainer (callout 1), and then separate the retainer from the assembly.

 **NOTE:** The retainer remains attached to the wire harness, and disengages from the assembly.

Figure 1-261 Remove the RD sensor assembly (5 of 6)



6. Remove the assembly.

Figure 1-262 Remove the RD sensor assembly (6 of 6)

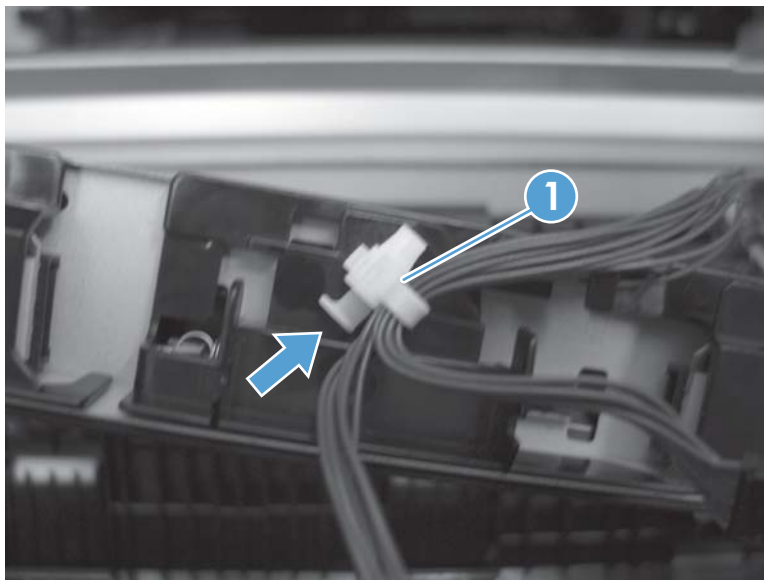
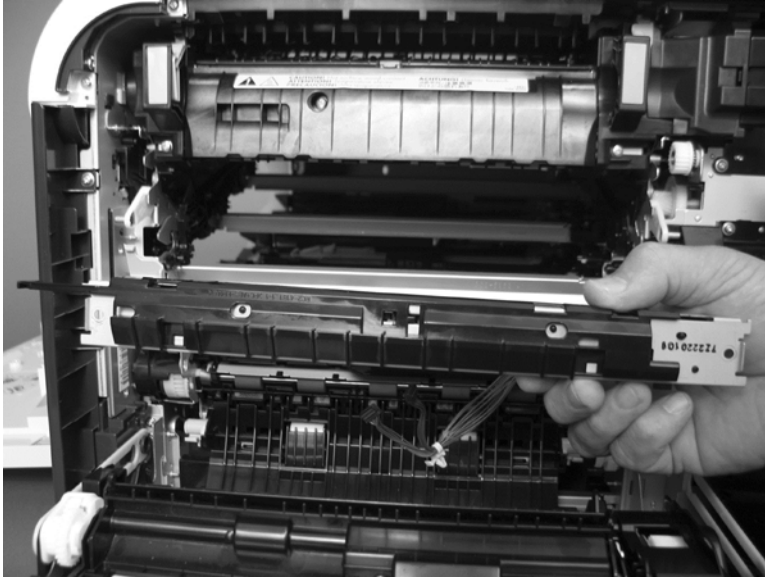

Power-supply fan and fan duct

Before proceeding, remove the following components:

- Toner-collection unit. See [Toner-collection unit on page 15](#).
- Right-rear cover. See [Right-rear cover on page 90](#).
- Left cover. See [Left cover on page 92](#).
- Rear-upper cover. See [Rear-upper cover on page 95](#).
- Rear cover. See [Rear cover on page 98](#).

Remove the power-supply fan and fan duct

1. Disconnect one connector (callout 1; J119) and release the wire harnesses from the guide (callout 2).

 **NOTE:** To locate DC controller connector locations, see [DC controller PCA on page 8](#).

Figure 1-263 Remove the power-supply fan (1 of 4)



- To remove the fan only:** Release two tabs (callout 1), and then remove the fan from the fan duct.

 **Reinstallation tip** When the fan is reinstalled, the air must flow into the product. Look at the arrows embossed on the fan frame that indicate air flow direction.

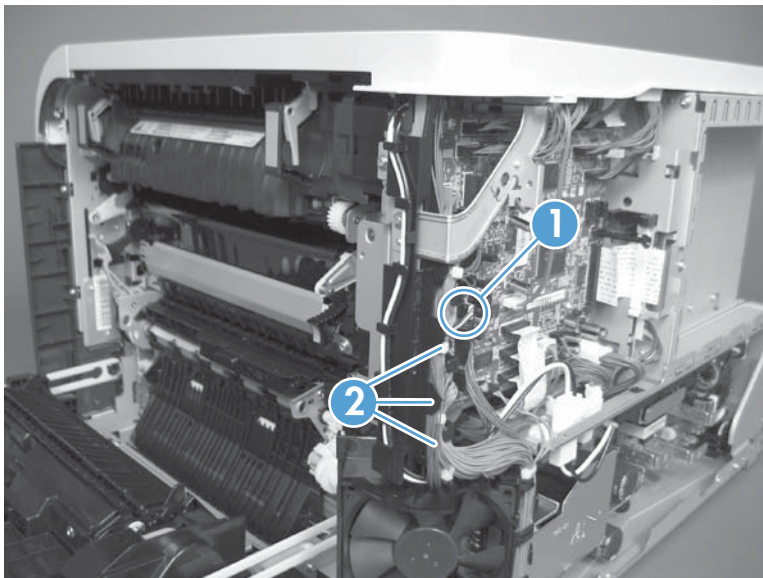
Figure 1-264 Remove the power-supply fan (2 of 4)



- To remove the fan and fan duct:** Remove one screw (callout 1), and then release the wire harnesses from the guides on the fan duct.

Figure 1-265 Remove the power-supply fan (3 of 4)

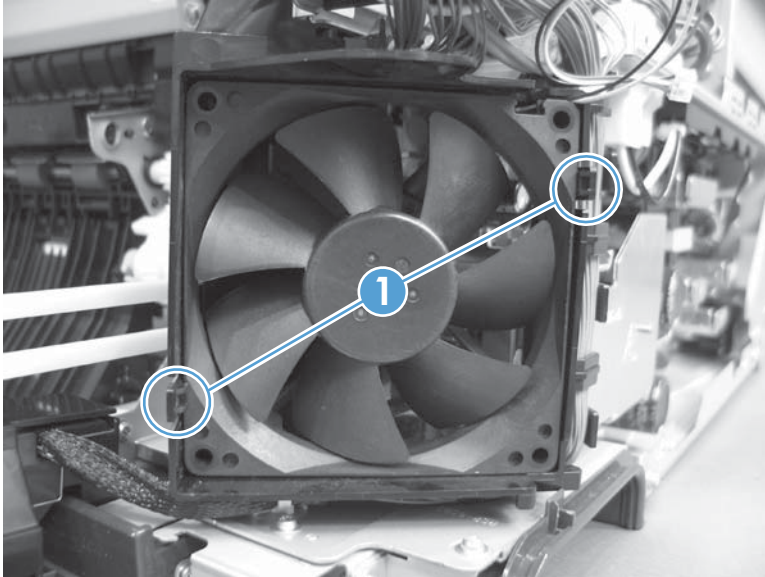
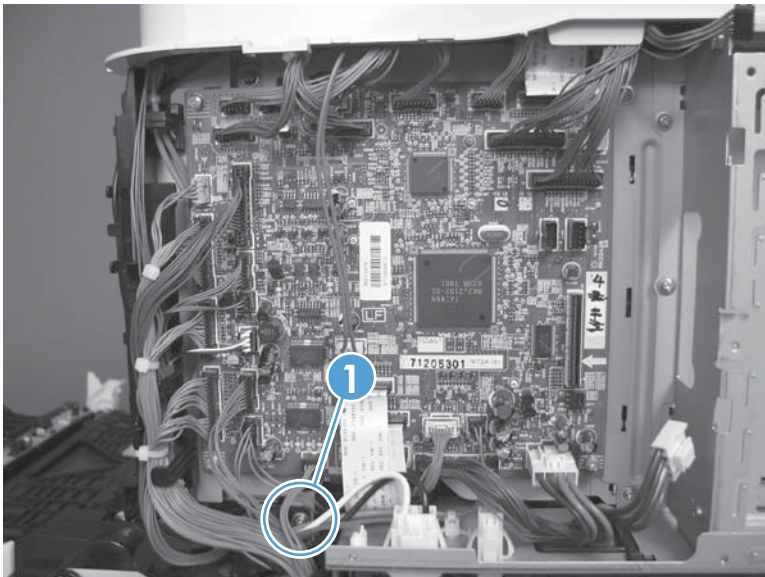

- 4. To remove the fan and fan duct:** Release one tab (callout 1), and then remove the fan and fan duct (callout 2).

Figure 1-266 Remove the power-supply fan (4 of 4)

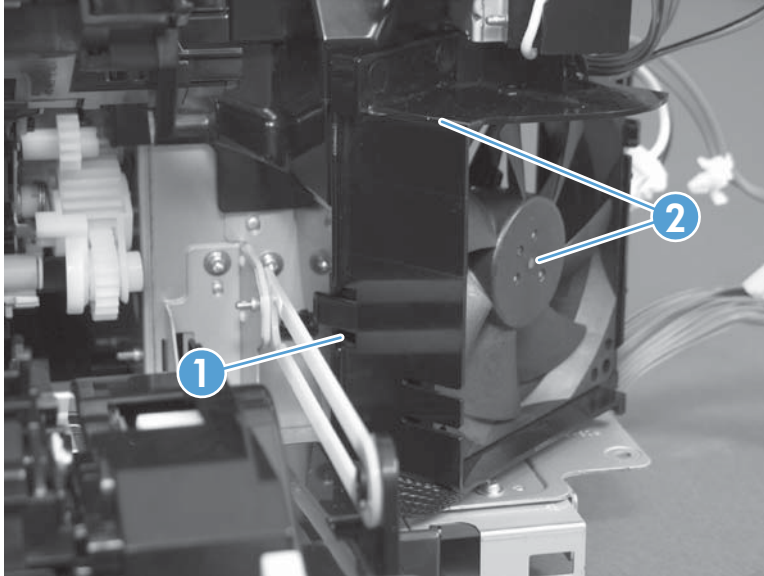

Registration assembly

Before proceeding, remove the following components:

- Toner-collection unit. See [Toner-collection unit on page 15](#).
- Intermediate transfer belt (ITB). See [Intermediate transfer belt \(ITB\) on page 34](#).
- Right-rear cover. See [Right-rear cover on page 90](#).
- Left cover. See [Left cover on page 92](#).
- Rear-upper cover. See [Rear-upper cover on page 95](#).
- Rear cover. See [Rear cover on page 98](#).
- Registration density (RD) sensor assembly. See [Registration density \(RD\) sensor assembly on page 177](#).

 **TIP:** Removing the RD sensor assembly makes it much easier to reinstall the registration assembly.

- Power-supply fan and fan duct. See [Power-supply fan and fan duct on page 181](#).
- Secondary transfer assembly. See [Secondary transfer assembly on page 171](#).

Remove the registration assembly

 **NOTE:** If a replacement registration assembly is installed, you must use the control-panel menus to reset the registration-roller count.

1. Remove two screws (callout 1).

Figure 1-267 Remove the registration assembly (1 of 8)

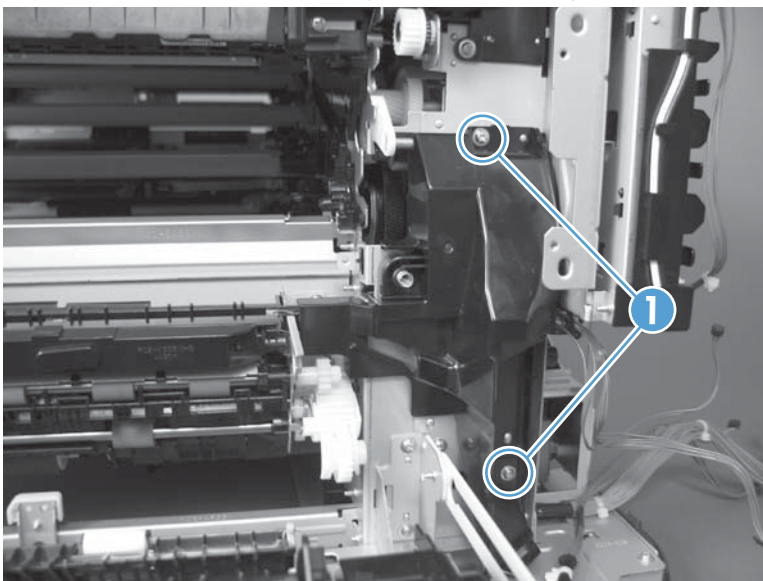

2. Pull down on the cover to release one tab, and then rotate the cover away from the product to remove it.

Figure 1-268 Remove the registration assembly (2 of 8)



3. Release two green latches (callout 1), and then lower the feed guide.

 **Reinstallation tip** Make sure that the feed guide snaps into the closed position when you reinstall the registration assembly.

Figure 1-269 Remove the registration assembly (3 of 8)



4. Remove three screws (callout 1).

Figure 1-270 Remove the registration assembly (4 of 8)

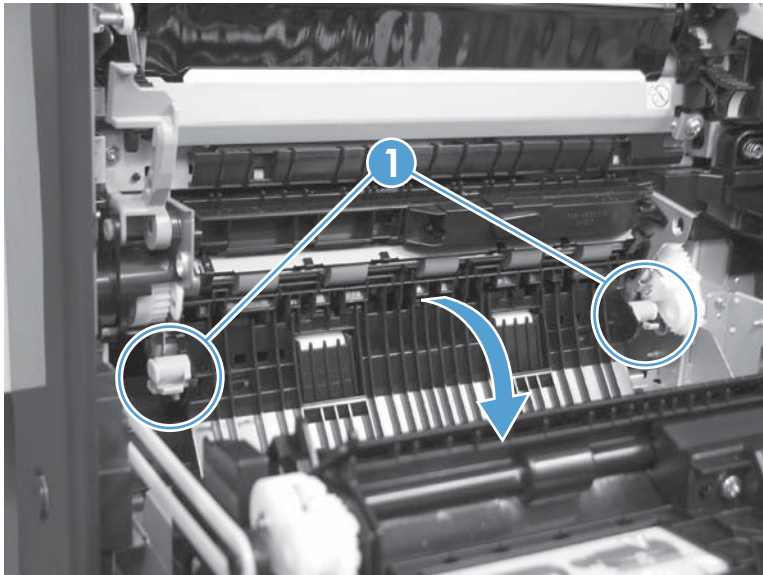
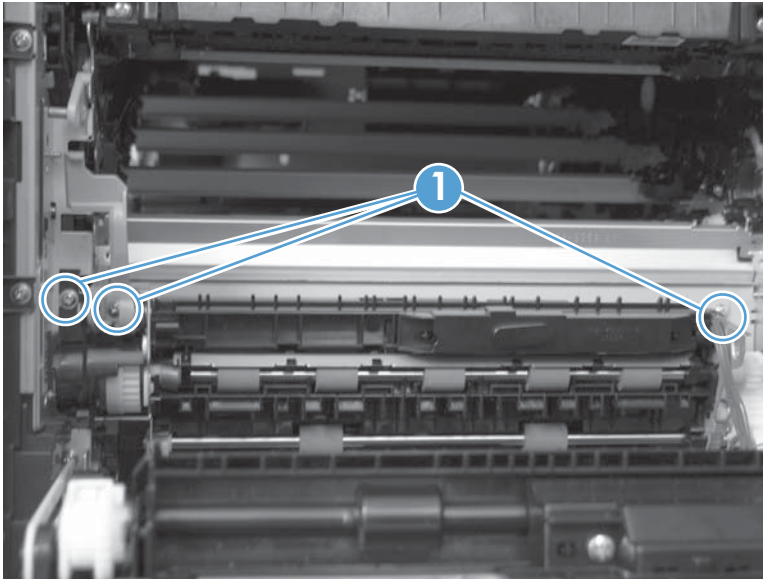

5. Separate the assembly from the product, release one tab (callout 1), and then remove the cover (callout 2).

CAUTION: The assembly is still attached to the product by the wire harnesses.

Figure 1-271 Remove the registration assembly (5 of 8)

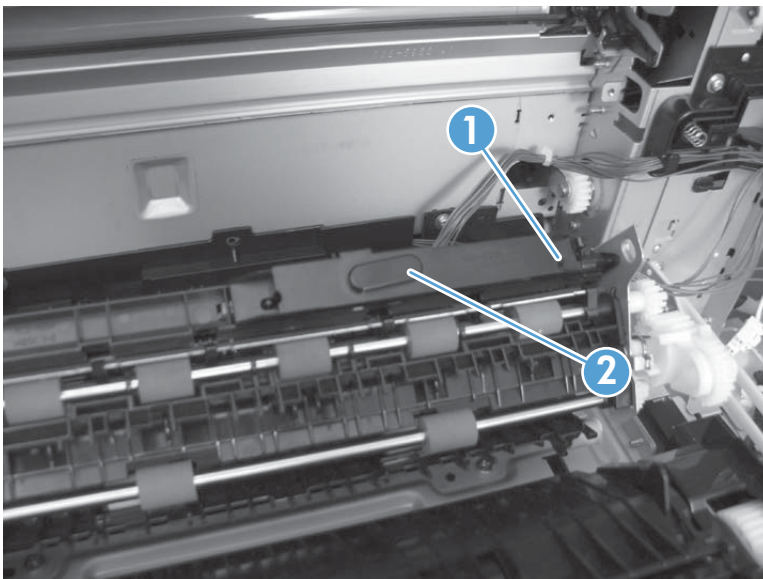

6. Disconnect one connector (callout 1), and then release the wire harness from the retainer.

Figure 1-272 Remove the registration assembly (6 of 8)

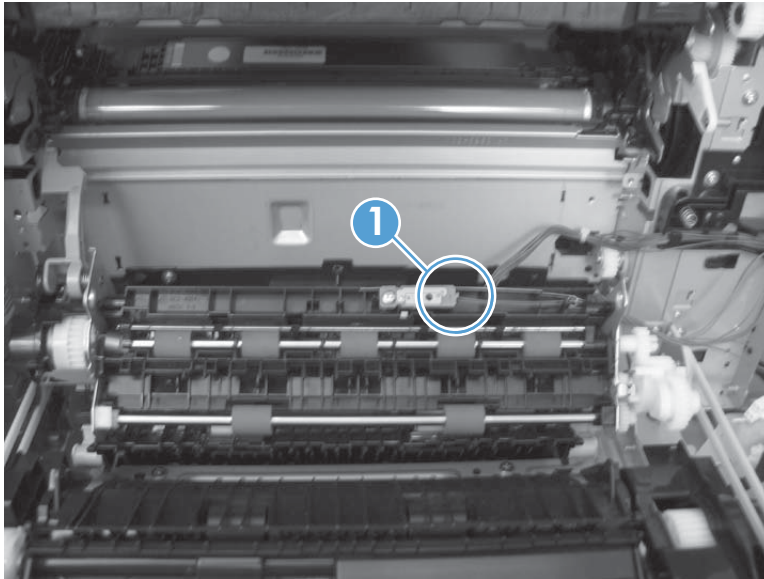

7. Disconnect three connectors (callout 1) on the back side of the assembly, and then release the wires from the retainers.

Figure 1-273 Remove the registration assembly (7 of 8)

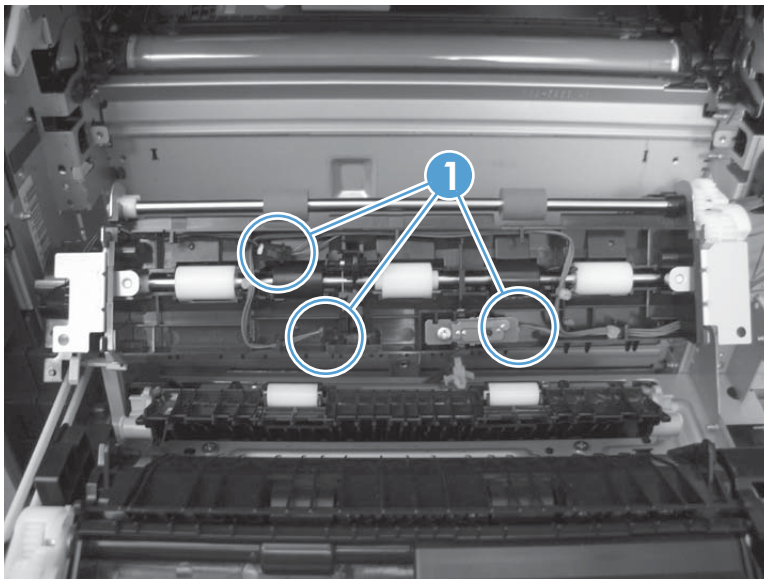

8. Remove the assembly.

 **Reinstallation tip** When you reinstall the registration assembly, make sure that it is correctly positioned in the product. The tabs on the assembly must fit into the slots in the product chassis and the assembly should fit securely up against the product chassis.

Figure 1-274 Remove the registration assembly (8 of 8)



High-voltage power supply lower

Before proceeding, remove the following components:

- Toner-collection unit. See [Toner-collection unit on page 15](#).
- Formatter PCA. See [Formatter PCA on page 17](#).
- Right-rear cover. See [Right-rear cover on page 90](#).
- Left cover. See [Left cover on page 92](#).
- Rear-upper cover. See [Rear-upper cover on page 95](#).
- Rear cover. See [Rear cover on page 98](#).
- Interconnect board (ICB). See [Interconnect board \(ICB\) on page 148](#).
- Low-voltage power supply (LVPS). See [Low-voltage power supply \(LVPS\) on page 153](#).

Remove the high-voltage power supply lower

CAUTION:  ESD-sensitive part.

1. Disconnect two connectors (callout 1), and then remove three screws (callout 2).

Figure 1-275 Remove the high-voltage power supply lower (1 of 4)

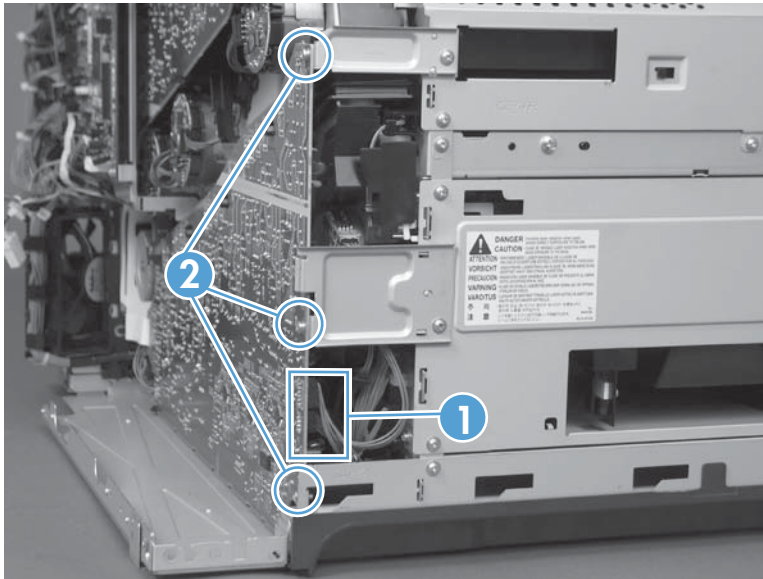

2. Use a small flat blade screwdriver to carefully remove three locking clips (callout 1).

⚠ CAUTION: Do not damage the PCA with the screwdriver.

Figure 1-276 Remove the high-voltage power supply lower (2 of 4)

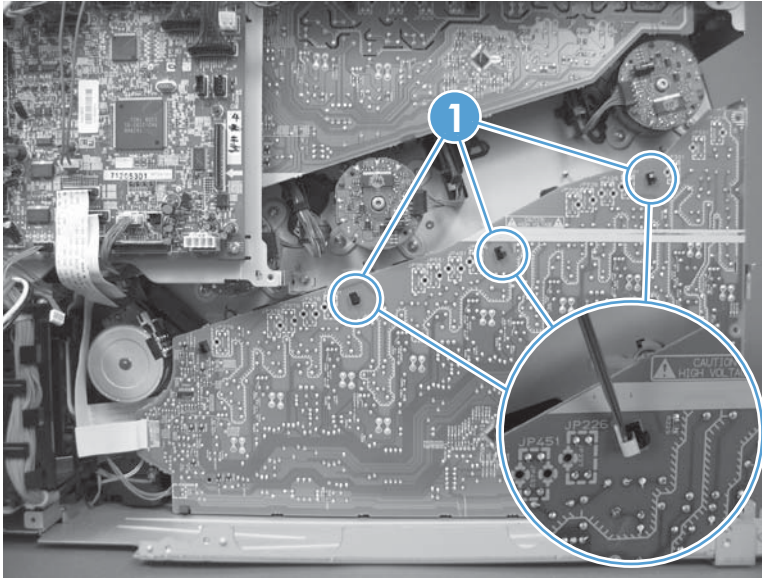

3. Disconnect one connector (callout 1; J114), and then release five clips (callout 2).

📝 NOTE: To locate DC controller connector locations, see [DC controller PCA on page 8](#).

Figure 1-277 Remove the high-voltage power supply lower (3 of 4)

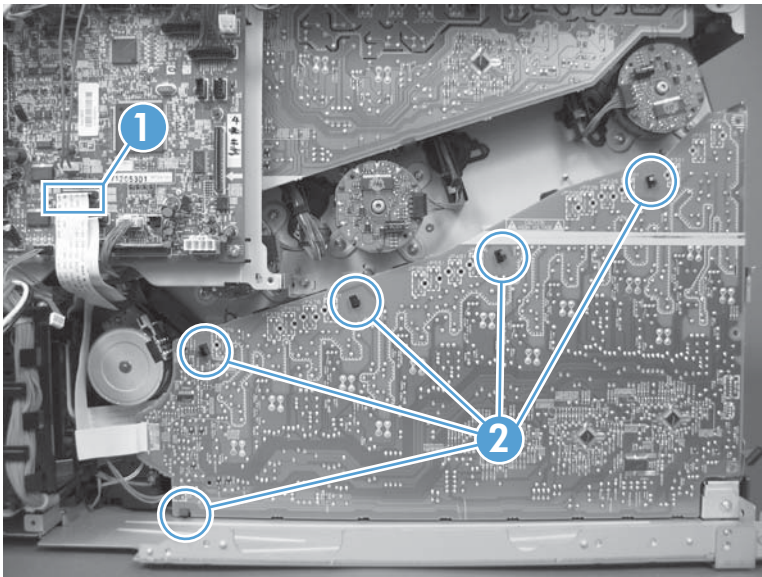

4. Rotate the top of the power supply away from the chassis, and then disconnect one connector (callout 1). Remove the power supply

Figure 1-278 Remove the high-voltage power supply lower (4 of 4)

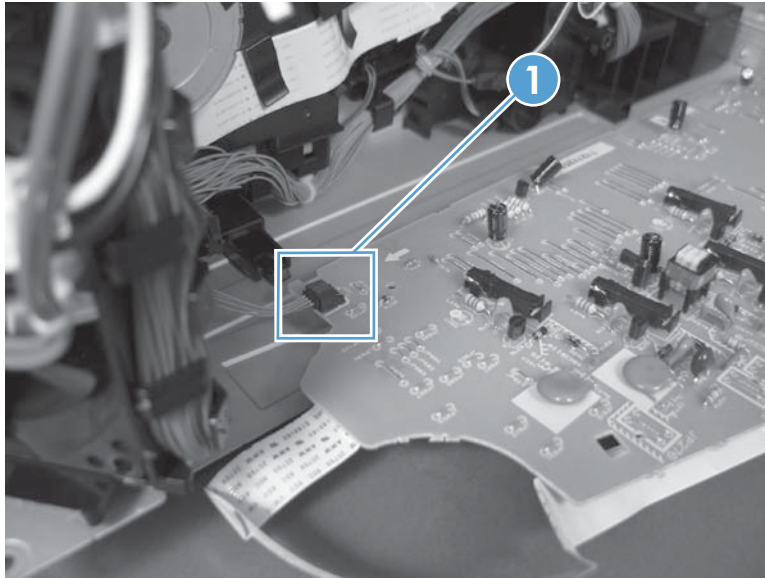

Reinstall the high-voltage power supply lower

When you reinstall the power supply, look through the holes in the PCA and make sure that the high-voltage contact springs are correctly seated against the PCA.

Figure 1-279 Reinstall the high-voltage power supply lower

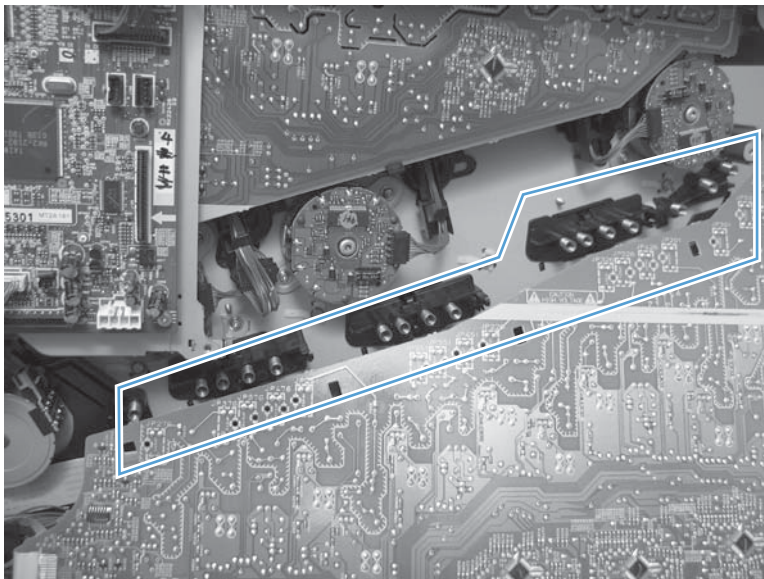

Developing-disengagement motor

Before proceeding, remove the following components:

- Toner-collection unit. See [Toner-collection unit on page 15](#).
- Formatter PCA. See [Formatter PCA on page 17](#).
- Right-rear cover. See [Right-rear cover on page 90](#).
- Left cover. See [Left cover on page 92](#).
- Rear-upper cover. See [Rear-upper cover on page 95](#).
- Rear cover. See [Rear cover on page 98](#).
- Interconnect board (ICB). See [Interconnect board \(ICB\) on page 148](#).
- Low-voltage power supply (LVPS). See [Low-voltage power supply \(LVPS\) on page 153](#).
- High-voltage power supply lower. See [High-voltage power supply lower on page 189](#).

Remove the developing-disengagement motor

1. Remove two screws (callout 1).

Figure 1-280 Remove the developing-disengagement motor (1 of 2)

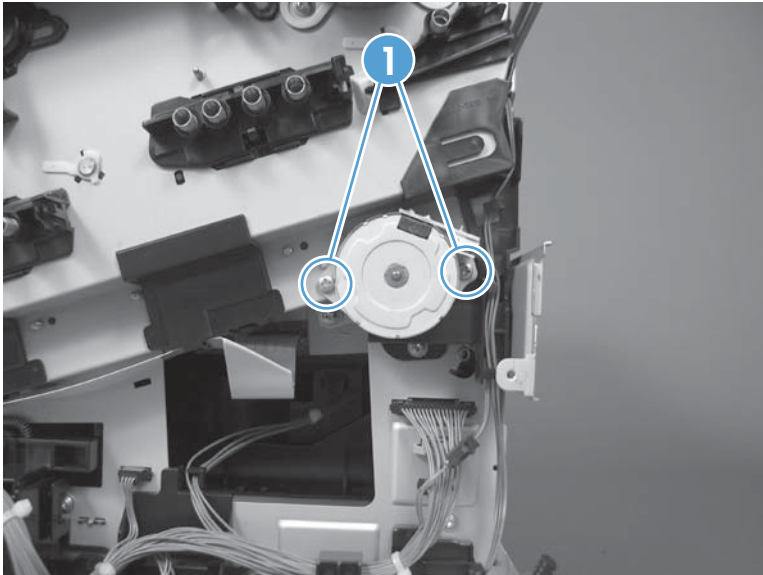

2. Remove the motor.

Figure 1-281 Remove the developing-disengagement motor (2 of 2)

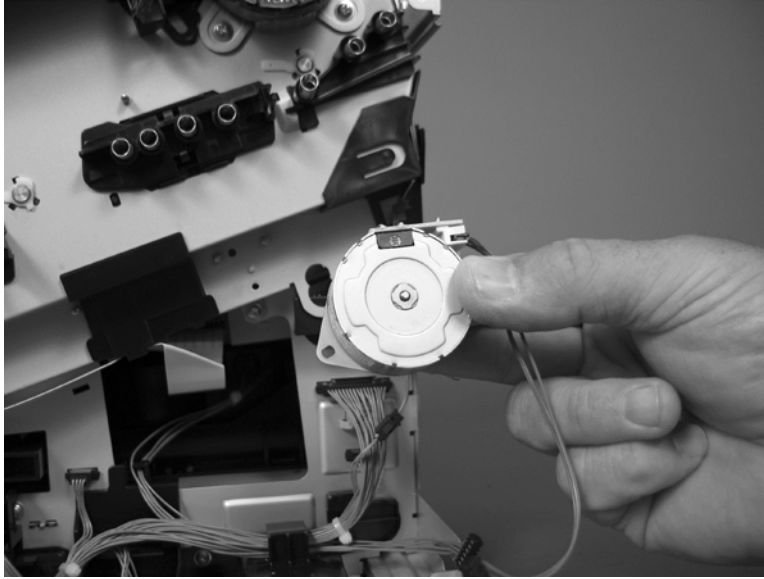

 **Reinstallation tip** Make sure the motor is installed correctly. The PCA on the motor should be on top when the installation is complete.

Pickup motor

Before proceeding, remove the following components:

- Toner-collection unit. See [Toner-collection unit on page 15](#).
- Formatter PCA. See [Formatter PCA on page 17](#).
- Right-rear cover. See [Right-rear cover on page 90](#).
- Left cover. See [Left cover on page 92](#).
- Rear-upper cover. See [Rear-upper cover on page 95](#).
- Rear cover. See [Rear cover on page 98](#).
- Interconnect board (ICB). See [Interconnect board \(ICB\) on page 148](#).
- Low-voltage power supply (LVPS). See [Low-voltage power supply \(LVPS\) on page 153](#).
- High-voltage power supply lower. See [High-voltage power supply lower on page 189](#).

Remove the pickup motor

Disconnect one connector (callout 1), remove two screws (callout 2), and then remove the motor.

Figure 1-282 Remove the pickup motor

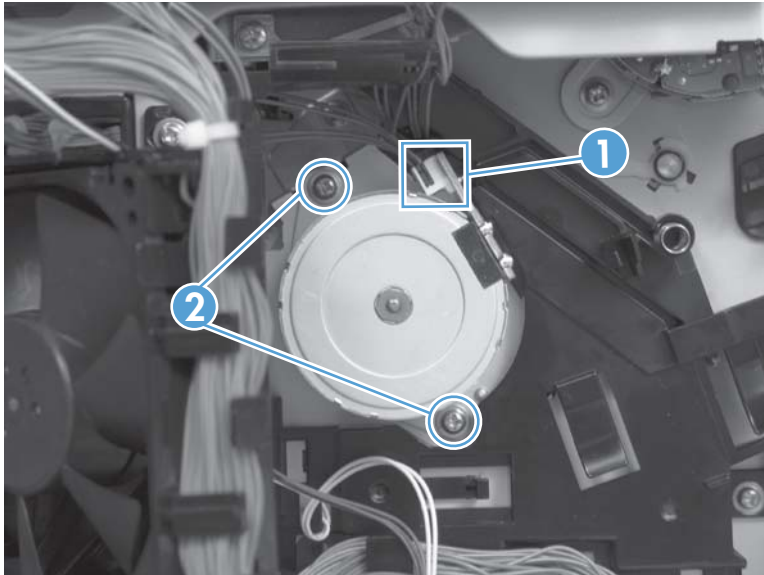

Lifter-drive assembly

Before proceeding, remove the following components:

- Toner-collection unit. See [Toner-collection unit on page 15](#).
- Formatter PCA. See [Formatter PCA on page 17](#).
- Right-rear cover. See [Right-rear cover on page 90](#).
- Left cover. See [Left cover on page 92](#).
- Rear-upper cover. See [Rear-upper cover on page 95](#).
- Rear cover. See [Rear cover on page 98](#).
- Interconnect board (ICB). See [Interconnect board \(ICB\) on page 148](#).
- Low-voltage power supply (LVPS). See [Low-voltage power supply \(LVPS\) on page 153](#).
- High-voltage power supply lower. See [High-voltage power supply lower on page 189](#).

Remove the lifter-drive assembly

1. Disconnect three connectors (callout 1), and then release the wire harness from the retainers.

Figure 1-283 Remove the lifter-drive assembly (1 of 2)

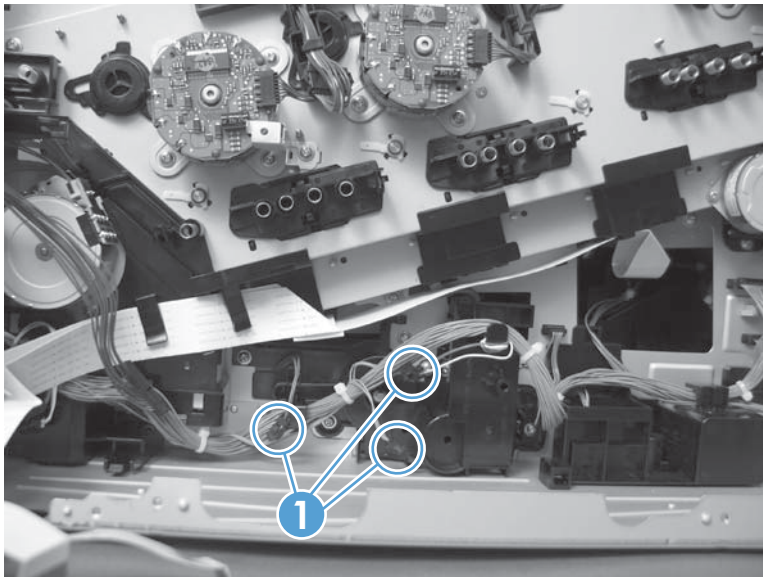

2. Remove five screws (callout 1), and then remove the assembly.

Figure 1-284 Remove the lifter-drive assembly (2 of 2)

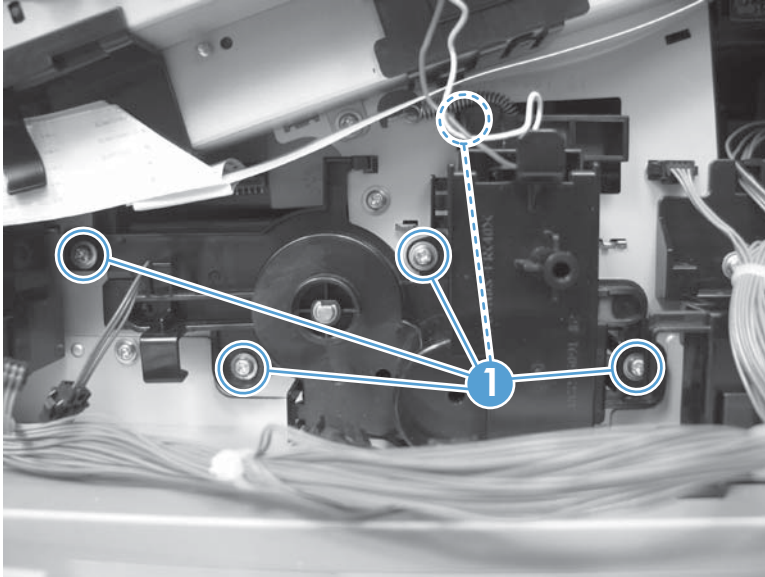

Tray-pickup drive assembly

Before proceeding, remove the following components:

- Toner-collection unit. See [Toner-collection unit on page 15](#).
- Formatter PCA. See [Formatter PCA on page 17](#).
- Right-rear cover. See [Right-rear cover on page 90](#).
- Left cover. See [Left cover on page 92](#).
- Rear-upper cover. See [Rear-upper cover on page 95](#).
- Rear cover. See [Rear cover on page 98](#).
- Interconnect board (ICB). See [Interconnect board \(ICB\) on page 148](#).
- Low-voltage power supply (LVPS). See [Low-voltage power supply \(LVPS\) on page 153](#).
- High-voltage power supply lower. See [High-voltage power supply lower on page 189](#).

Remove the tray-pickup drive assembly

 **NOTE:** To remove the pickup motor only, see [Pickup motor on page 194](#).

1. Remove one screw (callout 1), and then remove the sheet-metal bracket (callout 2).

Figure 1-285 Remove the tray-pickup drive assembly (1 of 10)

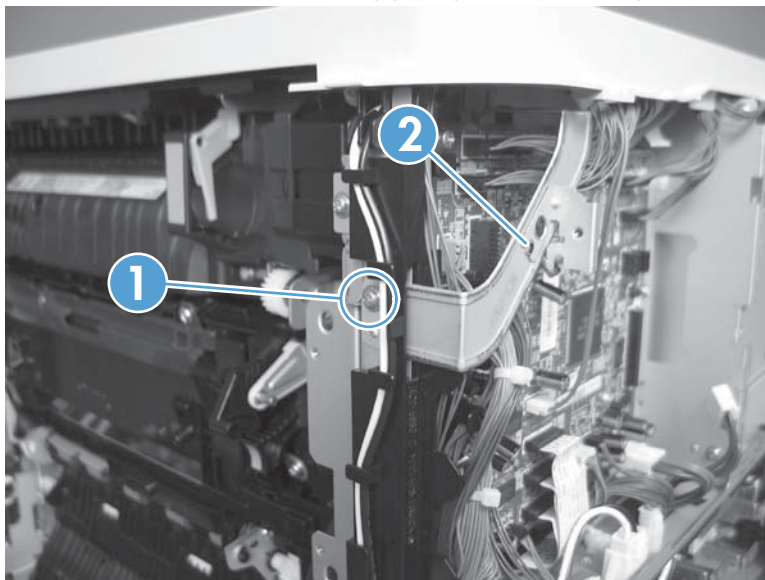

2. Disconnect six connectors (callout 1; J106, J107, J108, J137, J138, J140).

 **NOTE:** To locate DC controller connector locations, see [DC controller PCA on page 8](#).

Figure 1-286 Remove the tray-pickup drive assembly (2 of 10)

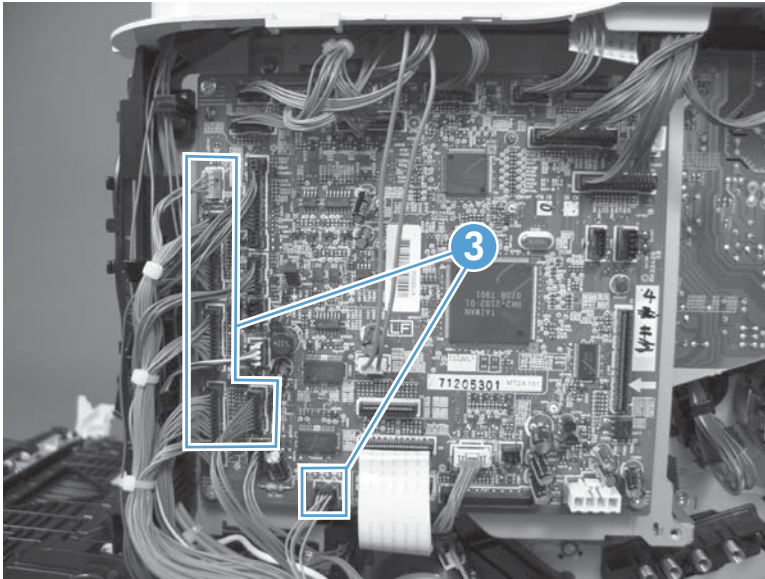

3. Disconnect one connector (callout 1; J119), remove one screw (callout 2), and then release the wire harness from the guides.

 **NOTE:** To locate DC controller connector locations, see [DC controller PCA on page 8](#).

Figure 1-287 Remove the tray-pickup drive assembly (3 of 10)

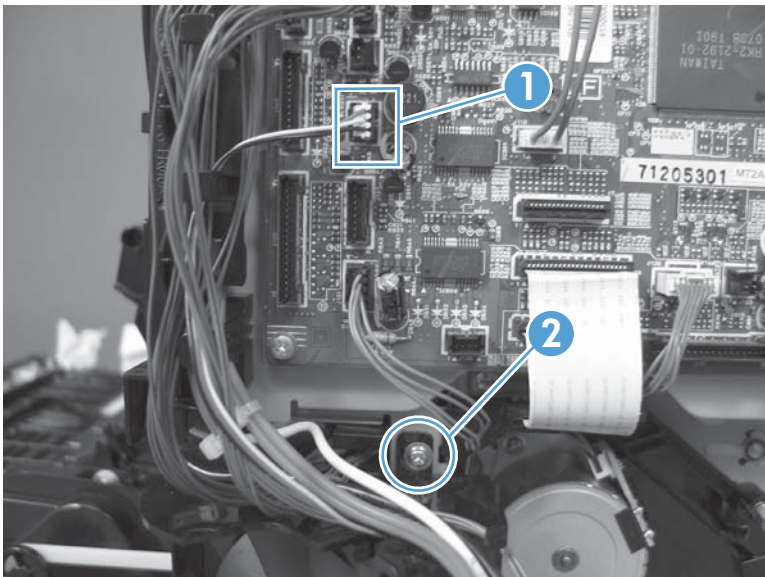

4. Release one tab (callout 1), and then remove the fan and fan duct (callout 2).

Figure 1-288 Remove the tray-pickup drive assembly (4 of 10)

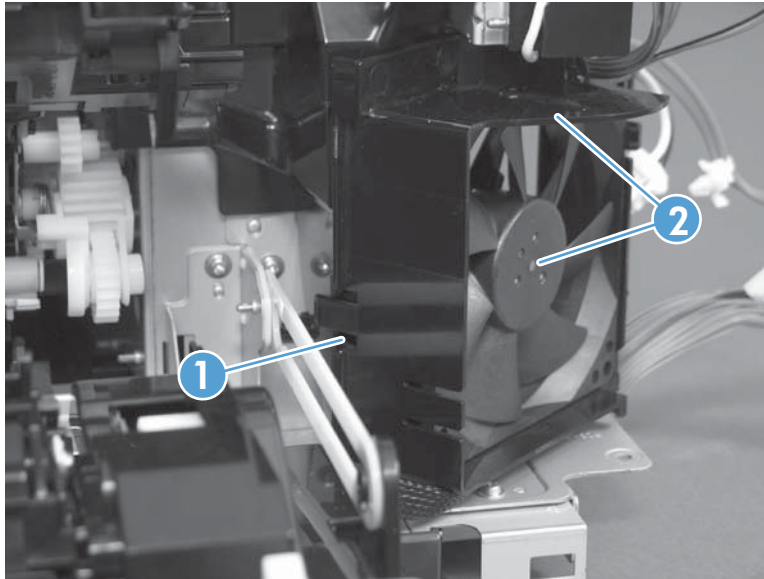

5. Disconnect five connectors (callout 1; J110, J111 on the DC controller PCA), release the FFCs from the guide (callout 2), and then release the wire harnesses from the guides.

 **NOTE:** To locate DC controller connector locations, see [DC controller PCA on page 8](#).

Figure 1-289 Remove the tray-pickup drive assembly (5 of 10)

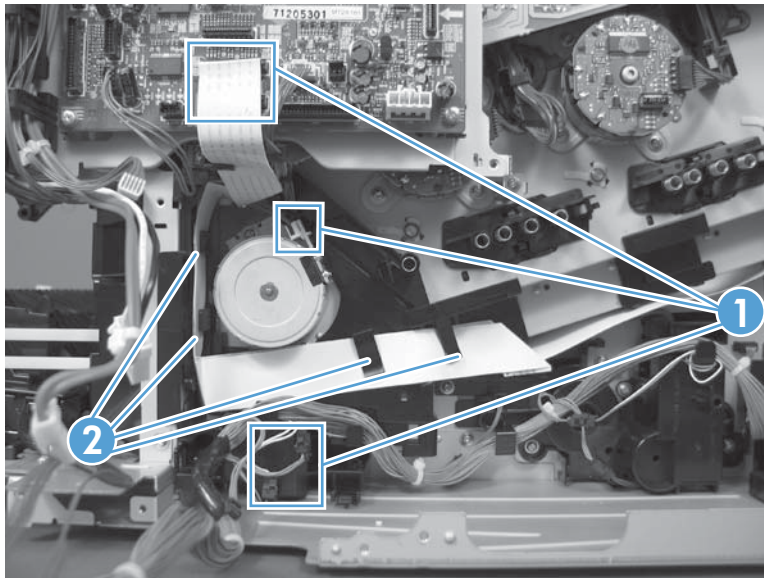

6. Release one tab (callout 1), and then remove the guide.

Figure 1-290 Remove the tray-pickup drive assembly (6 of 10)

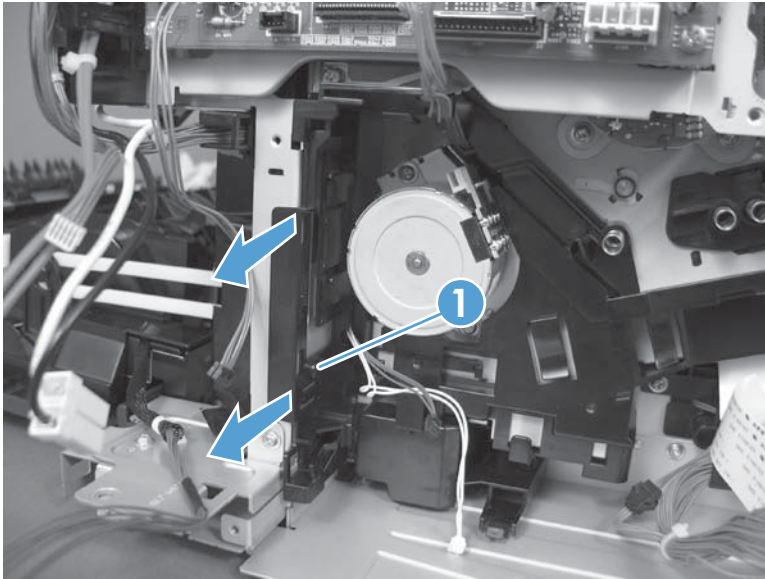

7. Release one tab (callout 1), and then remove the guide.

Figure 1-291 Remove the tray-pickup drive assembly (7 of 10)

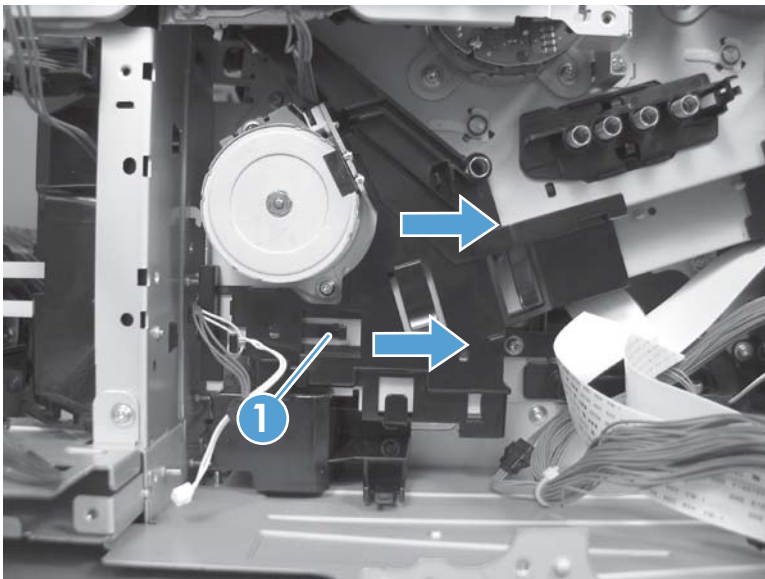

8. Remove two screws (callout 1), and then remove the high-voltage bracket (callout 2).

Figure 1-292 Remove the tray-pickup drive assembly (8 of 10)

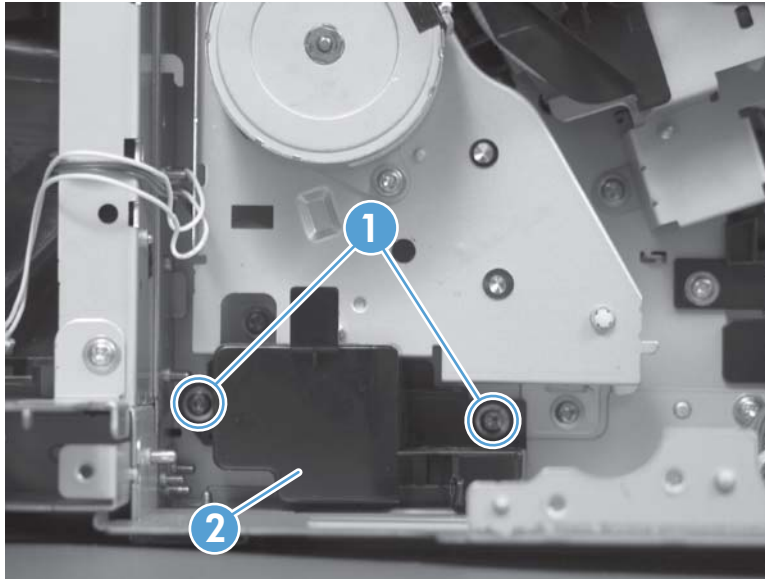

9. Remove three screws (callout 1).

Figure 1-293 Remove the tray-pickup drive assembly (9 of 10)

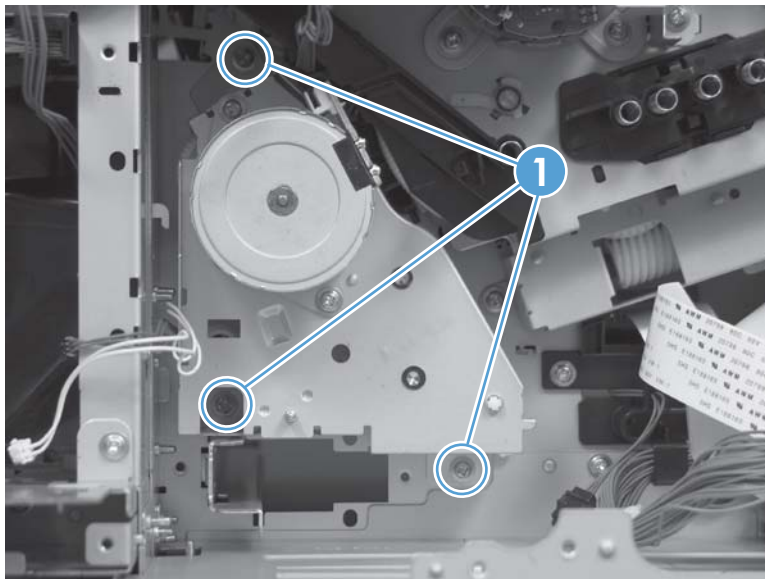

10. Carefully remove the assembly.

⚠ CAUTION: The gears, arm, and spring on the assembly are not captive. Use your finger to secure the arm and spring as you remove the assembly. If the gears, arm, or spring become dislodged, see [Reinstall the tray-pickup drive assembly on page 202](#).

Figure 1-294 Remove the tray-pickup drive assembly (10 of 10)

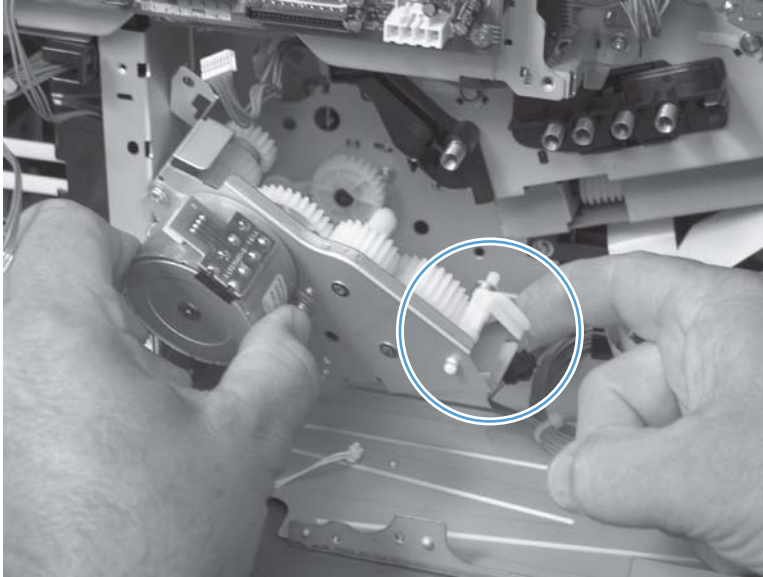

Reinstall the tray-pickup drive assembly

1. Make sure that the spring-loaded gear (callout 1) is correctly installed.

Figure 1-295 Reinstall the tray-pickup drive assembly (1 of 3)

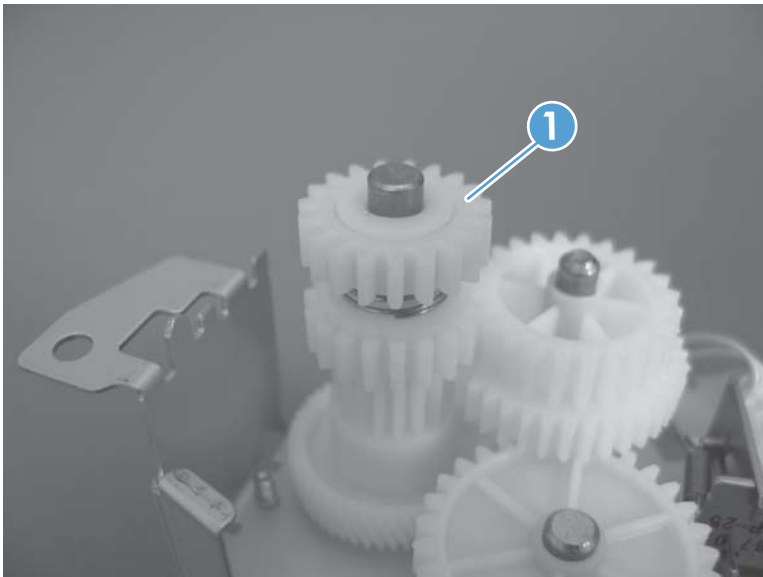

2. Make sure that the spring (callout 1) is correctly installed.

Figure 1-296 Reinstall the tray-pickup drive assembly (2 of 3)

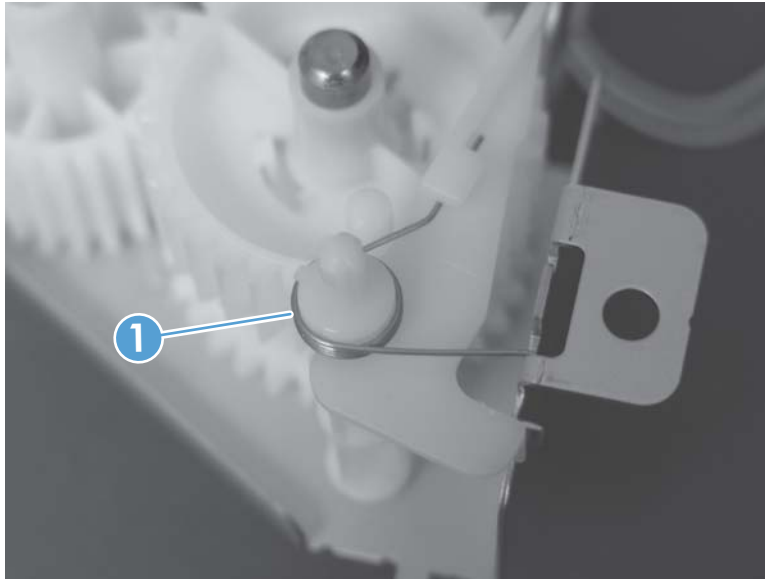

3. Make sure that the gears, arm, and spring are correctly installed.

Figure 1-297 Reinstall the tray-pickup drive assembly (3 of 3)

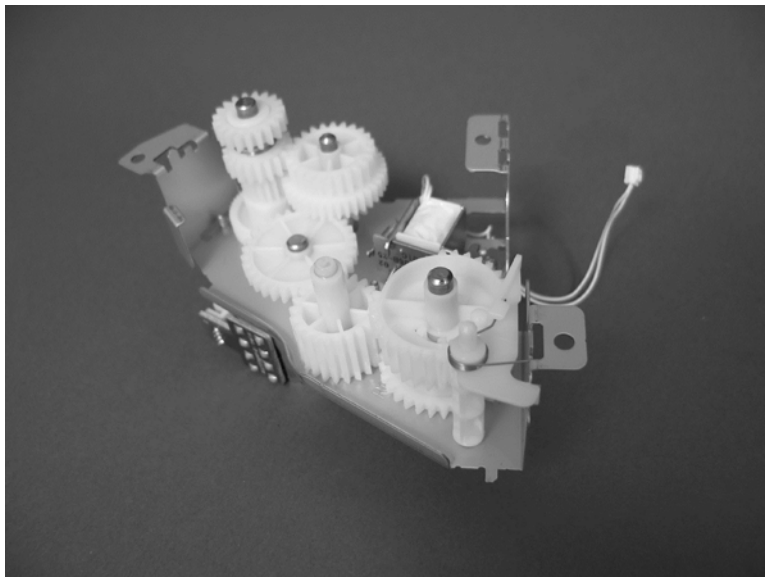

Tray-pickup assembly

Before proceeding, remove the following components:

- Toner-collection unit. See [Toner-collection unit on page 15](#).
- Formatter PCA. See [Formatter PCA on page 17](#).
- Right-rear cover. See [Right-rear cover on page 90](#).
- Left cover. See [Left cover on page 92](#).
- Rear-upper cover. See [Rear-upper cover on page 95](#).
- Rear cover. See [Rear cover on page 98](#).
- Interconnect board (ICB). See [Interconnect board \(ICB\) on page 148](#).
- Low-voltage power supply (LVPS). See [Low-voltage power supply \(LVPS\) on page 153](#).
- Registration density (RD) sensor assembly. See [Registration density \(RD\) sensor assembly on page 177](#).
- High-voltage power supply lower. See [High-voltage power supply lower on page 189](#).
- Tray-pickup drive assembly. See [Tray-pickup drive assembly on page 197](#).

Remove the tray-pickup assembly

1. Release one tab (callout 1), and then remove the gear (callout 2).

Figure 1-298 Remove the tray-pickup assembly (1 of 3)

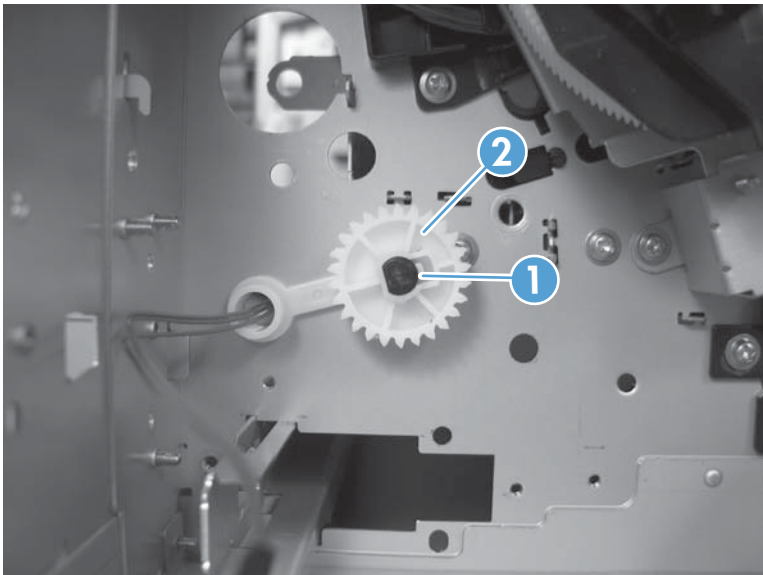

2. Remove two screws (callout 1).

Figure 1-299 Remove the tray-pickup assembly (2 of 3)

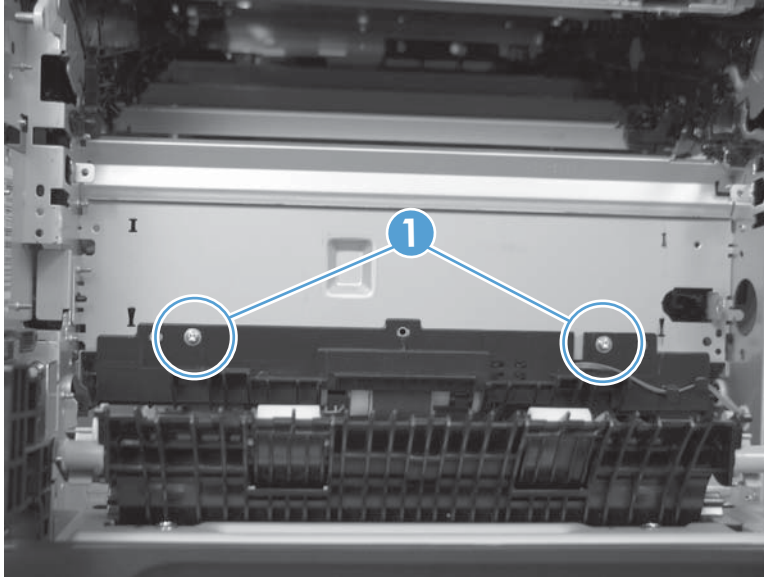

3. Remove the assembly.

Figure 1-300 Remove the tray-pickup assembly (3 of 3)



Laser/scanner assembly (Y/M)

Before proceeding, remove the following components:

- Toner-collection unit. See [Toner-collection unit on page 15](#).
- Formatter PCA. See [Formatter PCA on page 17](#).
- Right-rear cover. See [Right-rear cover on page 90](#).
- Left cover. See [Left cover on page 92](#).
- Rear-upper cover. See [Rear-upper cover on page 95](#).
- Rear cover. See [Rear cover on page 98](#).
- Interconnect board (ICB). See [Interconnect board \(ICB\) on page 148](#).
- Low-voltage power supply (LVPS). See [Low-voltage power supply \(LVPS\) on page 153](#).
- High-voltage power supply lower. See [High-voltage power supply lower on page 189](#).

Remove the laser/scanner assembly (Y/M)

1. Remove five screws (callout 1), and then remove the sheet-metal plate (callout 2).

Figure 1-301 Remove the laser/scanner assembly (Y/M) (1 of 12)

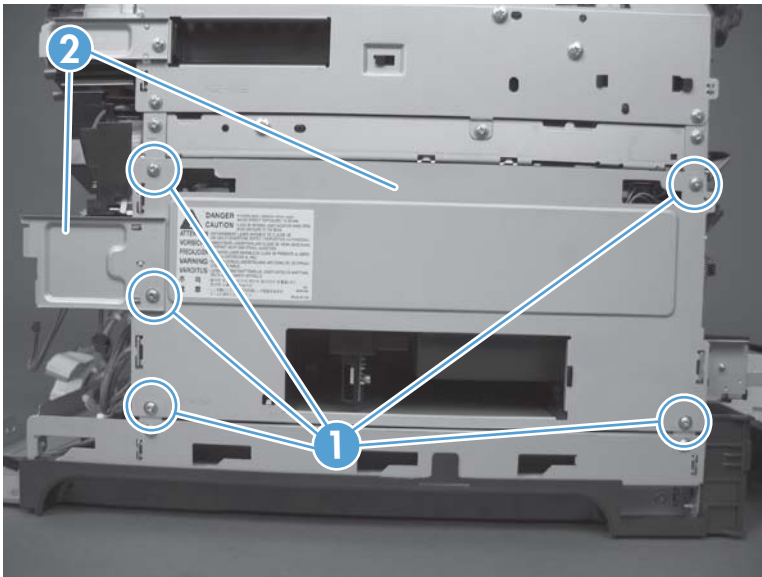

2. Disconnect in-line one connector (callout 1), and then release the wire harnesses from the guide (callout 2).

Figure 1-302 Remove the laser/scanner assembly (Y/M) (2 of 12)

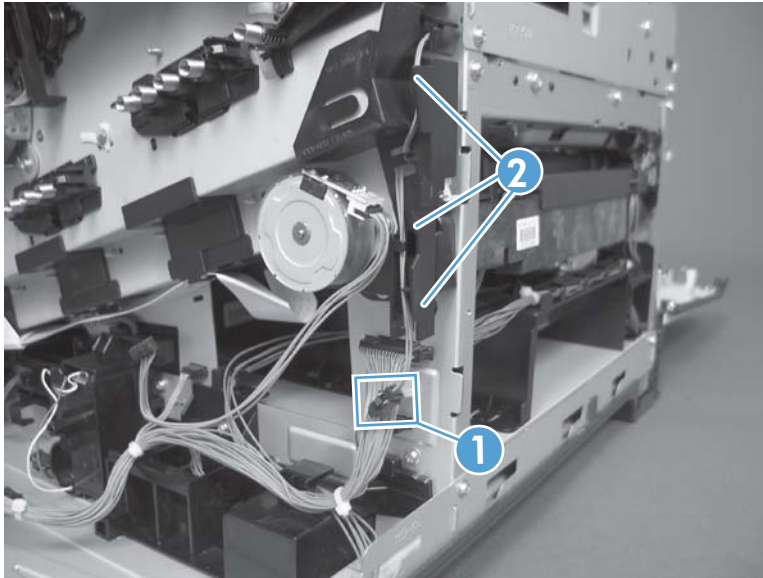

3. Release one tab (callout 1), and then remove the guide (callout 2).

Figure 1-303 Remove the laser/scanner assembly (Y/M) (3 of 12)

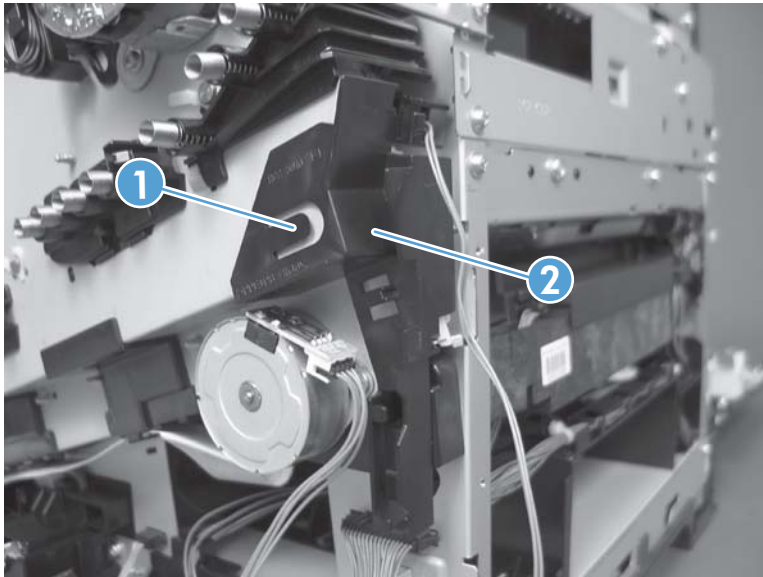

4. Remove one screw (callout 1), and then remove the cover (callout 2).

Figure 1-304 Remove the laser/scanner assembly (Y/M) (4 of 12)

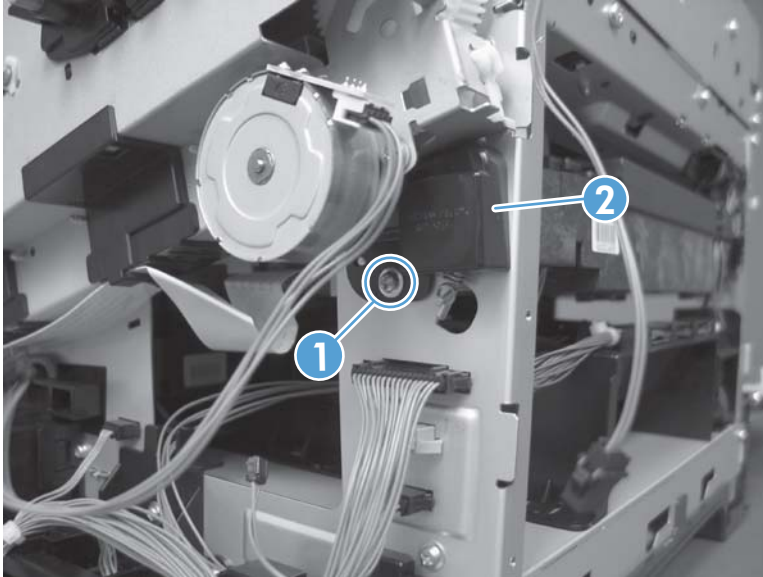

5. Disconnect one FFC (callout 1), and then release one spring (callout 2).

CAUTION: The spring is not captive. Do not lose the spring when it is removed. Use a pair of needle-nose pliers to safely retain the spring when it is removed. Do not use a flat blade screwdriver to remove the spring; the spring could forcibly leave the product and strike you.

Reinstallation tip When you reinstall the spring, make sure that the laser/scanner fits tightly up against the product chassis, and make sure that the FFC is fully seated in the connector. The locator tabs on the front and rear of the scanner must be firmly seated in the slots in the chassis.

Figure 1-305 Remove the laser/scanner assembly (Y/M) (5 of 12)

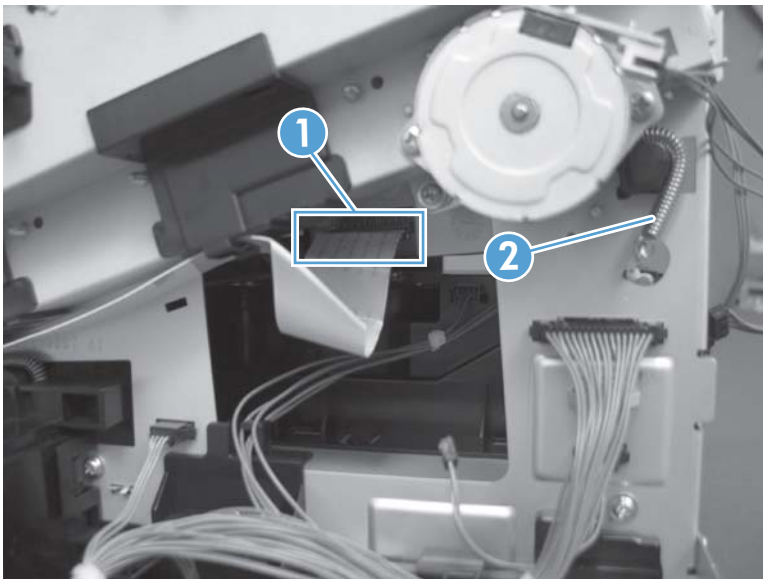

6. Disconnect six connectors (callout 1).

 **NOTE:** Disconnect the larger connector on the right side from the bottom. Disconnect the two smaller connectors on the right side from the top.

Figure 1-306 Remove the laser/scanner assembly (Y/M) (6 of 12)



7. Release two tabs (callout 1), and then slide the fan assembly toward the power-supply side of the product to release it.

Figure 1-307 Remove the laser/scanner assembly (Y/M) (7 of 12)

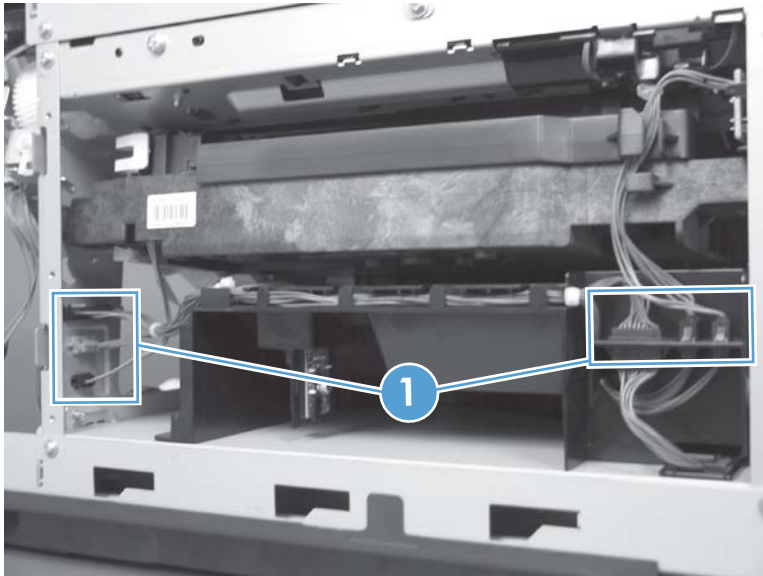
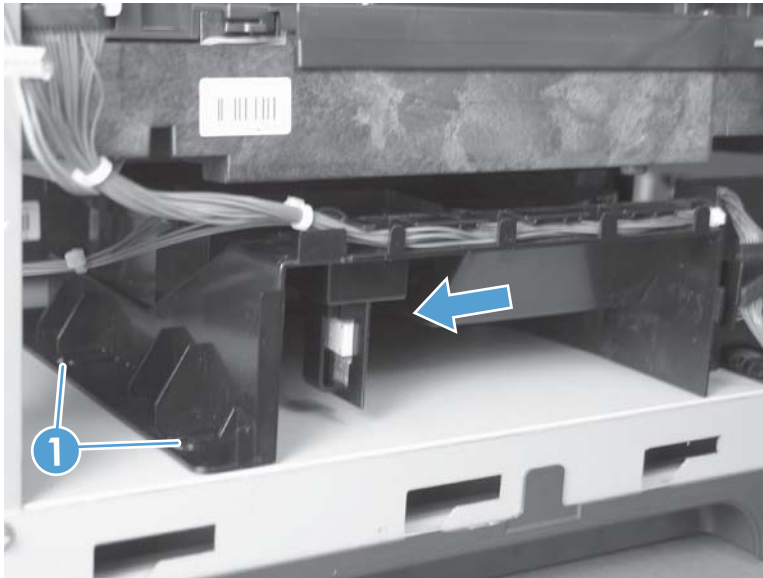

8. Pull the fan assembly slightly out of the product, disconnect two connectors (callout 1), and then remove the assembly.

Figure 1-308 Remove the laser/scanner assembly (Y/M) (8 of 12)

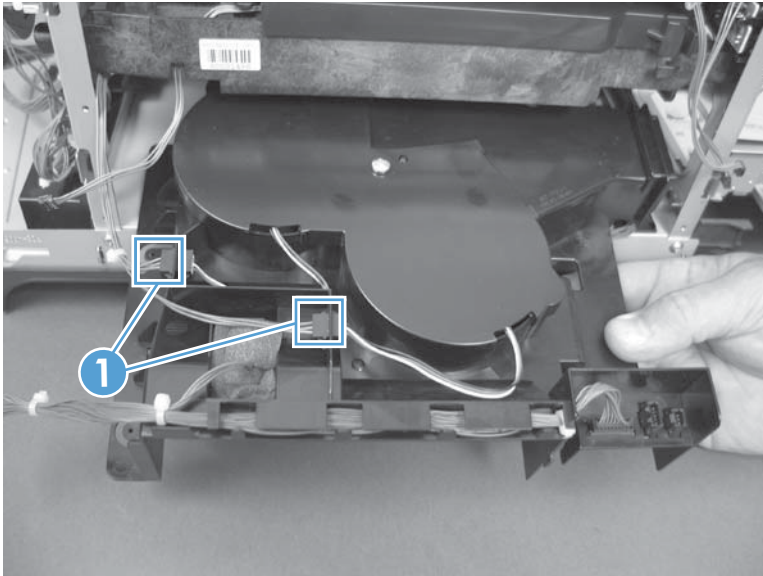

9. Remove one screw (callout 1), and then release one spring (callout 2).

CAUTION: The spring is not captive. Do not lose the spring when it is removed. Use a pair of needle-nose pliers to safely retain the spring when it is removed. Do not use a flat blade screwdriver to remove the spring; the spring could forcibly leave the product and strike you.

Reinstallation tip When the laser/scanner is properly positioned in the chassis, the plastic parts which protrude at the front and rear of the product will be firmly seated against the locator tabs on the chassis. Verify that the assembly is correctly seated, and then install the spring.

Figure 1-309 Remove the laser/scanner assembly (Y/M) (9 of 12)

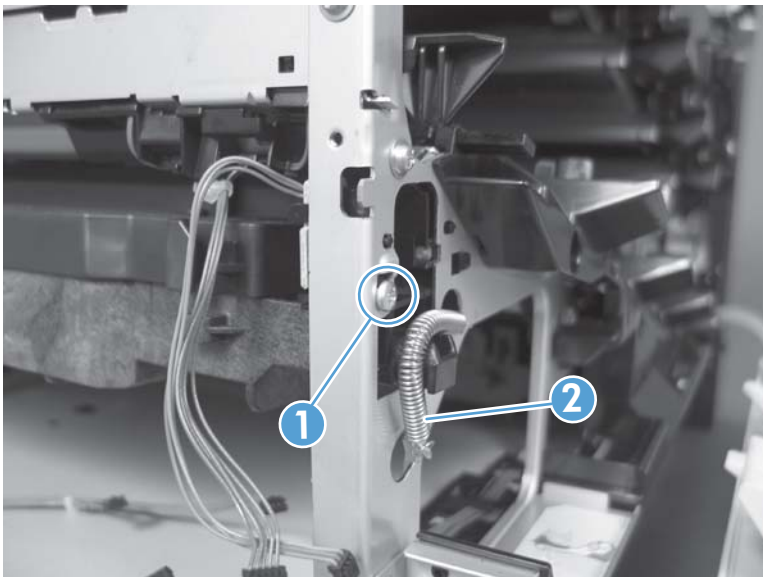

10. Remove the toner collection sensor.

Figure 1-310 Remove the laser/scanner assembly (Y/M) (10 of 12)

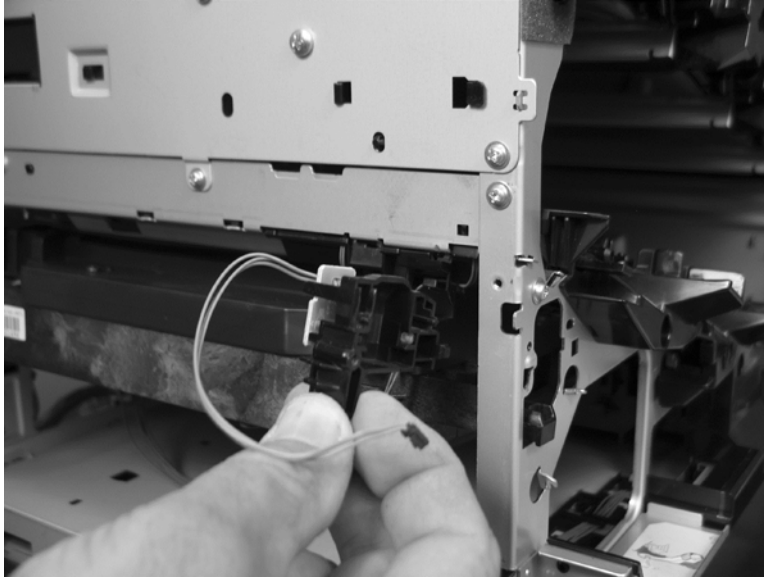

11. Rotate the front of the laser/scanner assembly down (callout 1), and then slide it toward the right (callout 2). Lower the left corner, and then rotate the left corner out of the product (callout 3).

Figure 1-311 Remove the laser/scanner assembly (Y/M) (11 of 12)

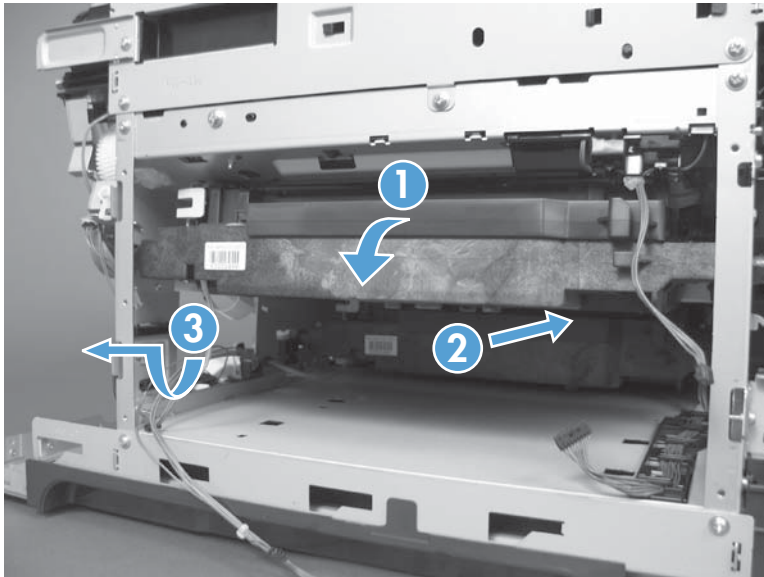

12. Pull the laser/scanner assembly straight out of the product to remove it.

Figure 1-312 Remove the laser/scanner assembly (Y/M) (12 of 12)



Laser/scanner assembly (C/Bk)

Before proceeding, remove the following components:

- Toner-collection unit. See [Toner-collection unit on page 15](#).
- Formatter PCA. See [Formatter PCA on page 17](#).
- Right-rear cover. See [Right-rear cover on page 90](#).
- Left cover. See [Left cover on page 92](#).
- Rear-upper cover. See [Rear-upper cover on page 95](#).
- Rear cover. See [Rear cover on page 98](#).
- Interconnect board (ICB). See [Interconnect board \(ICB\) on page 148](#).
- Low-voltage power supply (LVPS). See [Low-voltage power supply \(LVPS\) on page 153](#).
- High-voltage power supply lower. See [High-voltage power supply lower on page 189](#).
- Lifter drive assembly. See [Lifter-drive assembly on page 195](#).
- Laser/scanner assembly (Y/M). See [Laser/scanner assembly \(Y/M\) on page 206](#).

Remove the laser/scanner assembly (C/Bk)

1. Release one spring (callout 1), and then disconnect one connector (callout 2).

⚠ CAUTION: The spring is not captive. Do not lose the spring when it is removed. Use a pair of needle-nose pliers to safely retain the spring when it is removed. Do not use a flat blade screwdriver to remove the spring; the spring could forcibly leave the product and strike you.

💡 Reinstallation tip When you reinstall the spring, make sure that the laser/scanner fits tightly up against the product chassis, and make sure that the FFC is fully seated in the connector. The locator tabs on the front of the scanner must be firmly seated in the slots in the chassis.

Figure 1-313 Remove the laser/scanner assembly (C/Bk) (1 of 7)

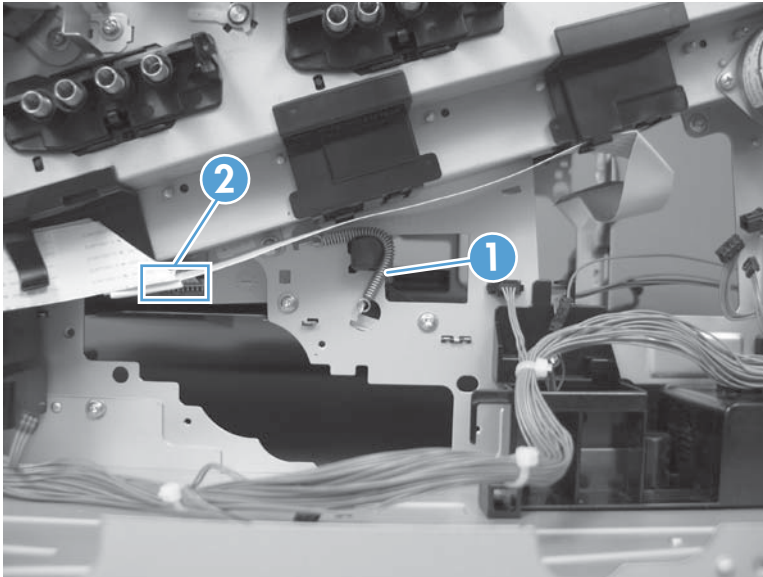

2. Disconnect one connector (callout 1).

Figure 1-314 Remove the laser/scanner assembly (C/Bk) (2 of 7)

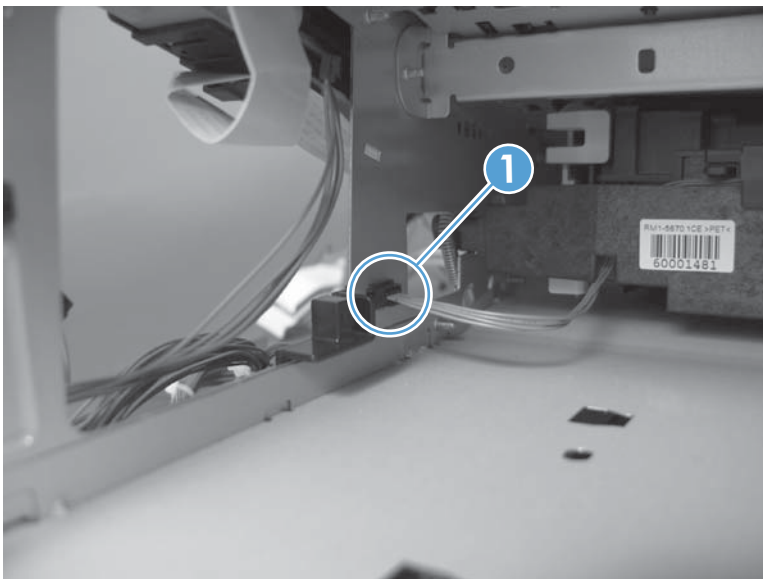

3. Remove two screws (callout 1) located below the front door.

Figure 1-315 Remove the laser/scanner assembly (C/Bk) (3 of 7)

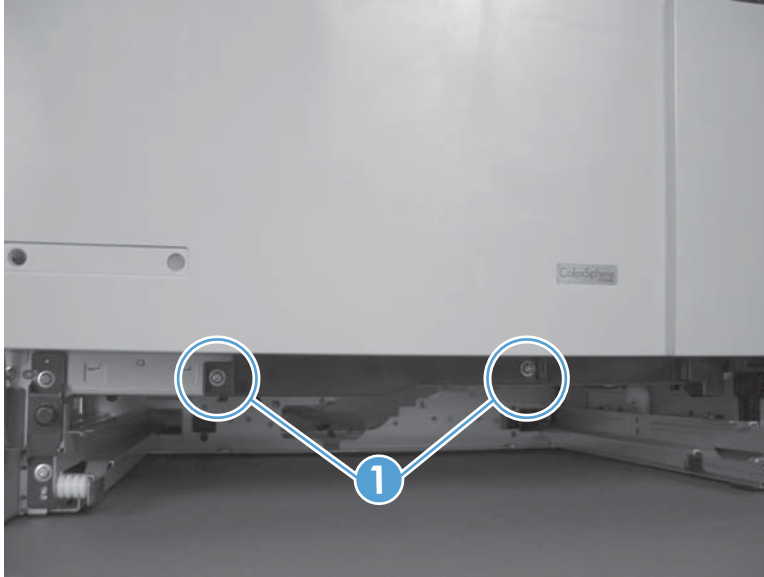

4. Open the front door, and then remove one screw (callout 1) and the cover (callout 2).

Figure 1-316 Remove the laser/scanner assembly (C/Bk) (4 of 7)

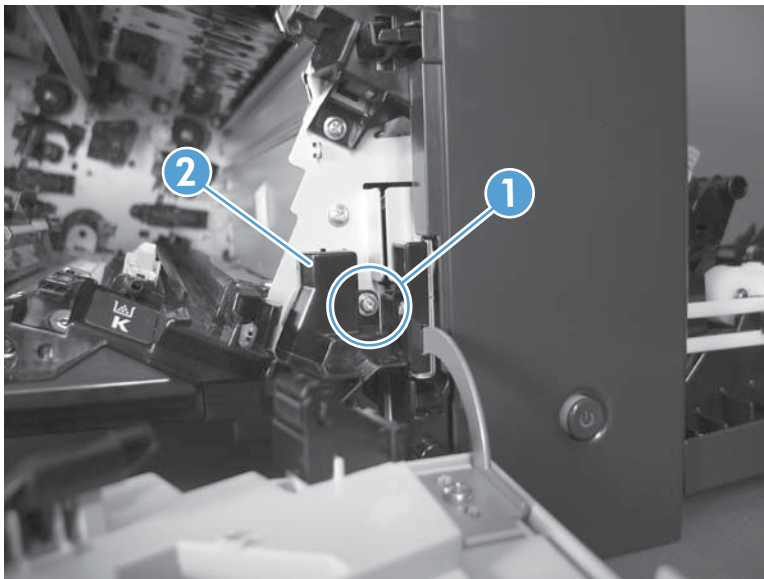

5. Remove two screws (callout 1). Use your finger to release the locking tab (callout 2), and then remove the cover.

⚠ CAUTION: Be careful. The PGC actuators are easily dislodged when the cover is removed. See [Figure 1-320 Reinstall the PGC actuators \(1 of 5\) on page 218](#). To reinstall the actuators, see [Reinstall the protective glass cleaner \(PGC\) actuators on page 218](#).

Figure 1-317 Remove the laser/scanner assembly (C/Bk) (5 of 7)

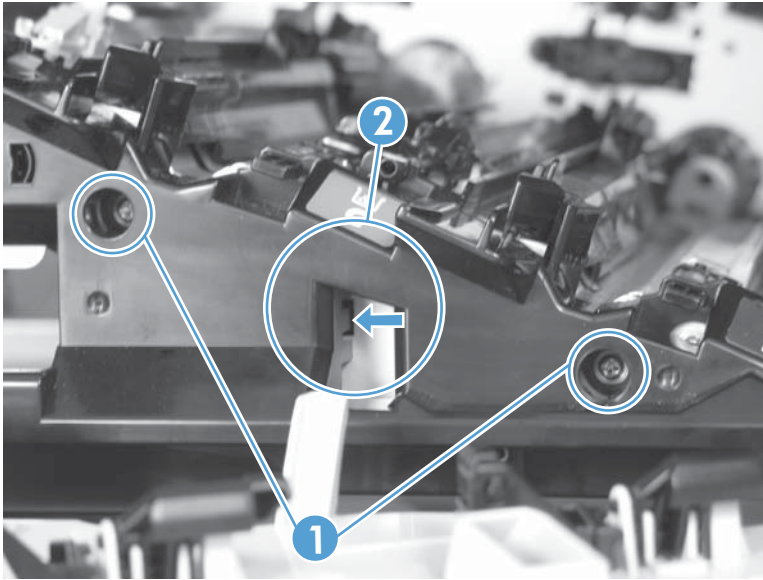

6. Release one spring (callout 1).

⚠ CAUTION: The spring is not captive. Do not lose the spring when it is removed. Use a pair of needle-nose pliers to safely retain the spring when it is removed. Do not use a flat blade screwdriver to remove the spring; the spring could forcibly leave the product and strike you.

💡 Reinstallation tip When you reinstall the spring, make sure that the laser/scanner fits tightly up against the product chassis.

Figure 1-318 Remove the laser/scanner assembly (C/Bk) (6 of 7)

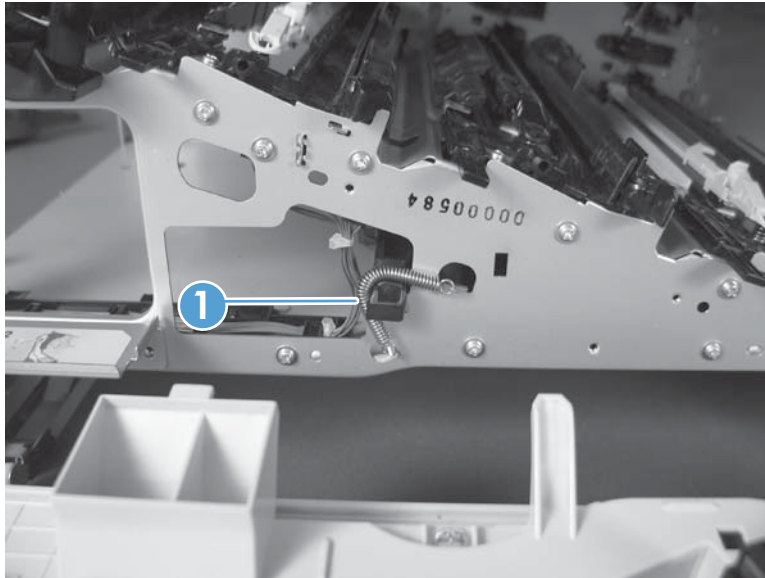

7. Rotate the corner of the assembly away from the product until you can see the PCA, and then remove the assembly from the product.

 **Reinstallation tip** When the laser/scanner is properly positioned in the chassis, the plastic parts which protrude at the front and rear of the product will be firmly seated against the locator tabs on the chassis. Verify that the assembly is correctly seated, and then install the spring.

Figure 1-319 Remove the laser/scanner assembly (C/Bk) (7 of 7)



Reinstall the protective glass cleaner (PGC) actuators

1. The following figure shows a dislodged PGC actuator.

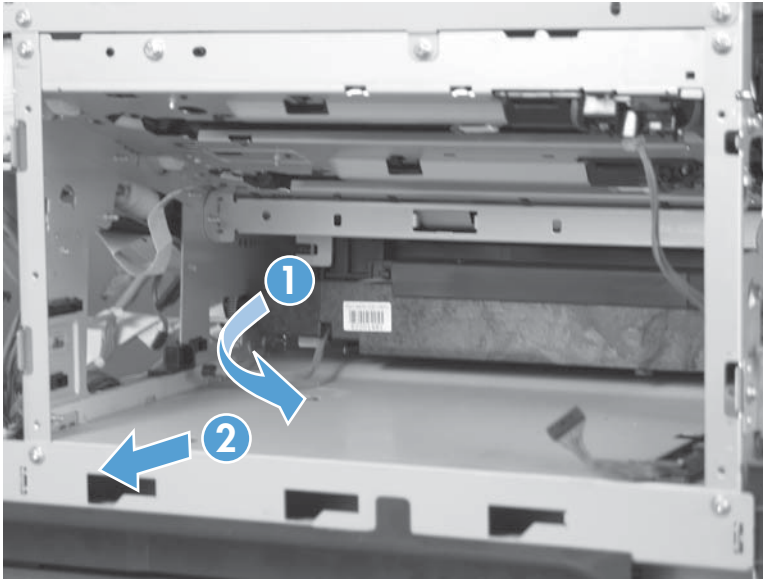
 **TIP:** If the actuator and spring are only slightly dislodged, you might be able to easily push them back into place.

Figure 1-320 Reinstall the PGC actuators (1 of 5)



2. Remove the actuator and spring from the product. Install the spring on the actuator.

Figure 1-321 Reinstall the PGC actuators (2 of 5)

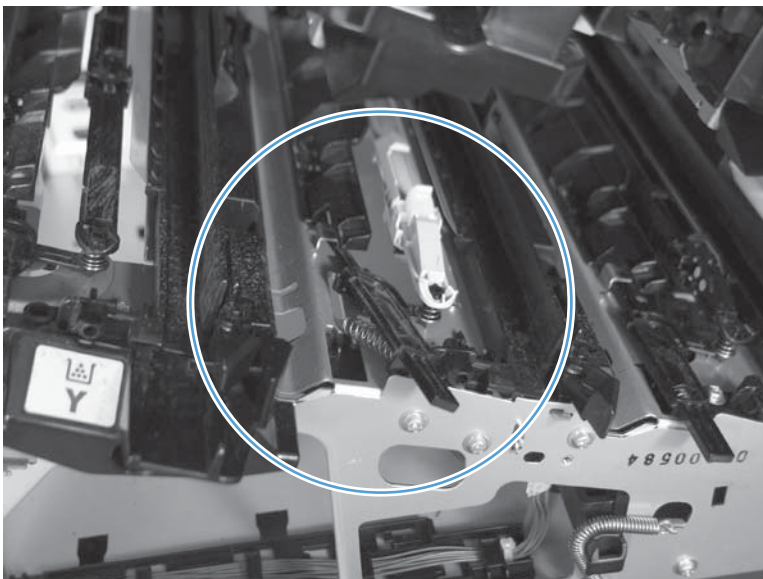

3. Before proceeding, take note of the following:
 - **Callout 1:** The pin on the actuator will be installed into the slot in the chassis.
 - **Callout 2:** The pin on the pivot arm will be installed into the slot on the actuator.
 - **Callout 3:** The end of the spring will be installed onto the tab on the chassis.

Figure 1-322 Reinstall the PGC actuators (3 of 5)

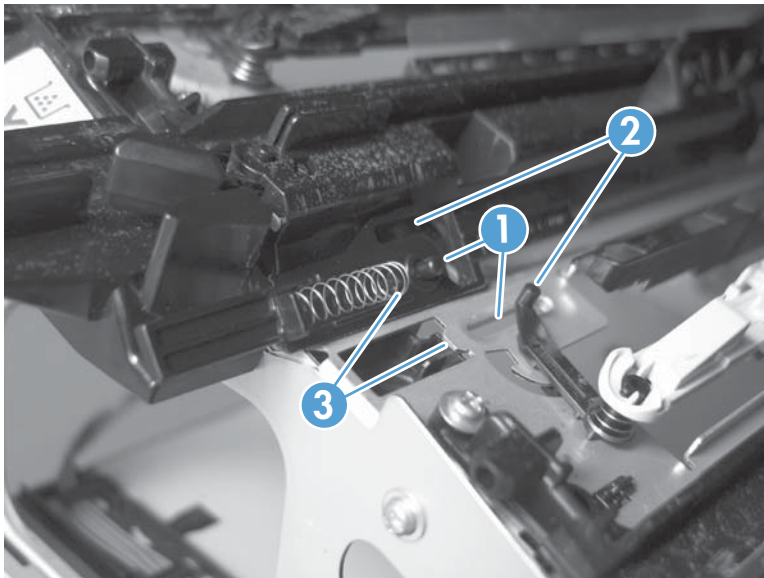

4. Place the end of the actuator into the PGC rod, and then use a small flat blade screw driver to fasten the end of the spring on the tab on the chassis.

Figure 1-323 Reinstall the PGC actuators (4 of 5)

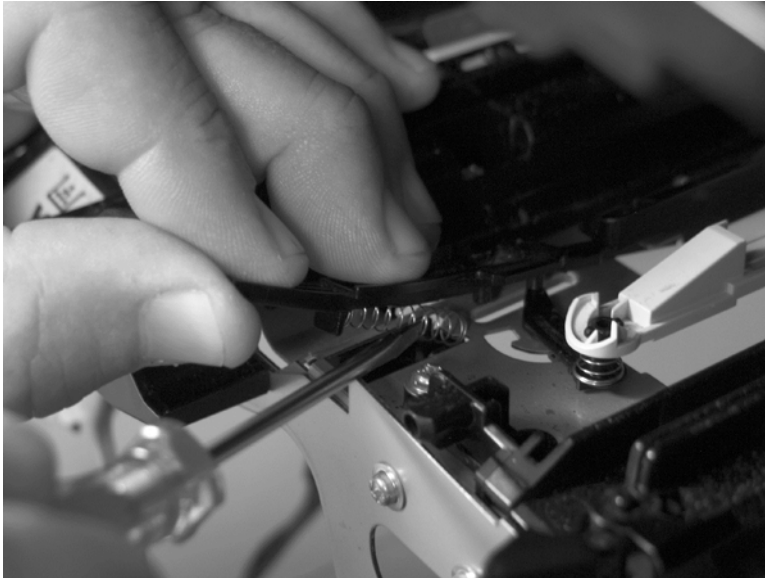

5. Push down on the actuator to seat it into place. Verify that the actuators is correctly installed. The PGC actuator should freely move when you push in on the actuator.

Figure 1-324 Reinstall the PGC actuators (5 of 5)

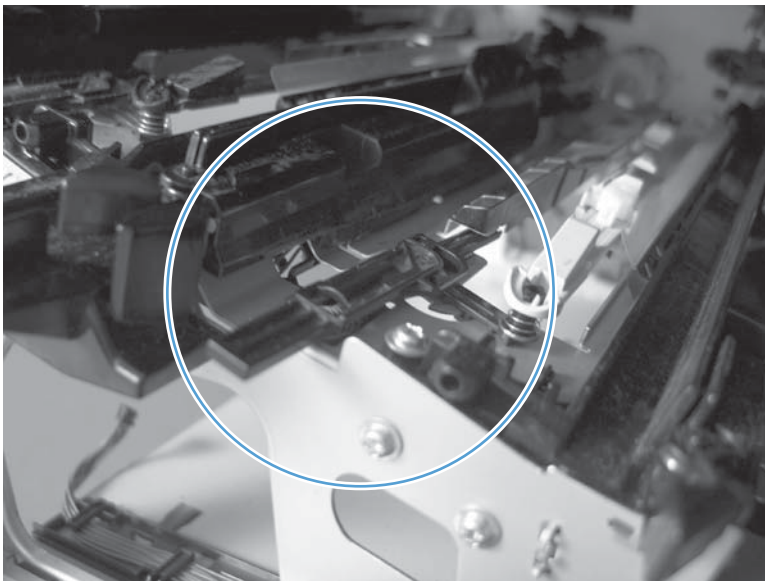

High-voltage power supply upper

Before proceeding, remove the following components:

- Toner-collection unit. See [Toner-collection unit on page 15](#).
- Formatter PCA. See [Formatter PCA on page 17](#).
- Right-rear cover. See [Right-rear cover on page 90](#).
- Left cover. See [Left cover on page 92](#).
- Rear-upper cover. See [Rear-upper cover on page 95](#).
- Rear cover. See [Rear cover on page 98](#).
- Interconnect board (ICB). See [Interconnect board \(ICB\) on page 148](#).
- DC controller. See [DC controller PCA and tray on page 150](#).
- Low-voltage power supply (LVPS). See [Low-voltage power supply \(LVPS\) on page 153](#).

Remove the high-voltage power supply upper

 **CAUTION:**  ESD-sensitive part.

1. Remove one screw (callout 1).

Figure 1-325 Remove the high-voltage power supply upper (1 of 5)

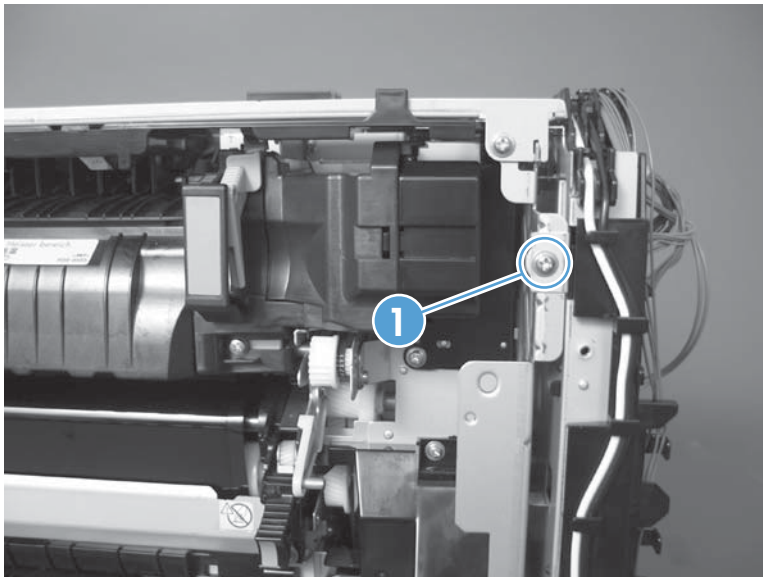

2. Remove four screws (callout 1), and then rotate the sheet-metal plate away from the power supply.

 **NOTE:** You do not need to completely remove the sheet-metal plate to access the power supply.

Figure 1-326 Remove the high-voltage power supply upper (2 of 5)



3. Disconnect two connectors (callout 1; J201, J202) from the back side of the power supply.

 **NOTE:** For clarity, the figure in this step shows the document feeder and scanner removed. Carefully reach under these components to access the two connectors.

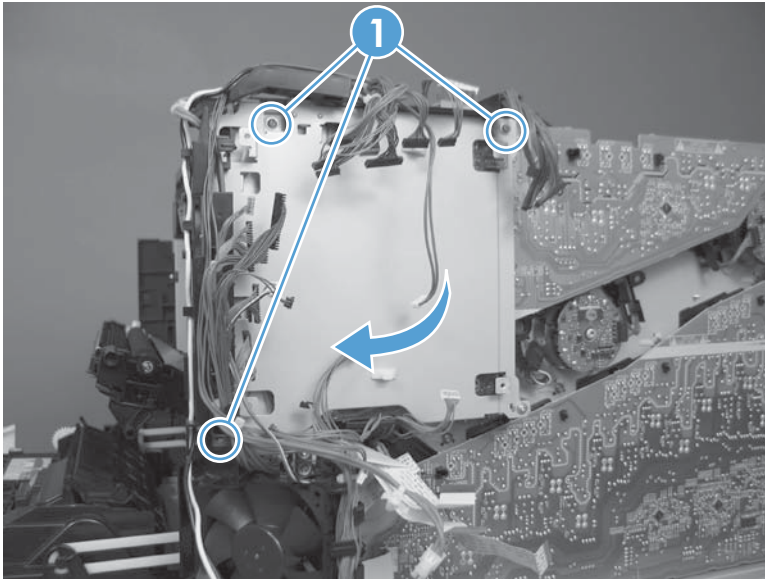
Figure 1-327 Remove the high-voltage power supply upper (3 of 5)



4. Remove three screws (callout 1).

Figure 1-328 Remove the high-voltage power supply upper (4 of 5)

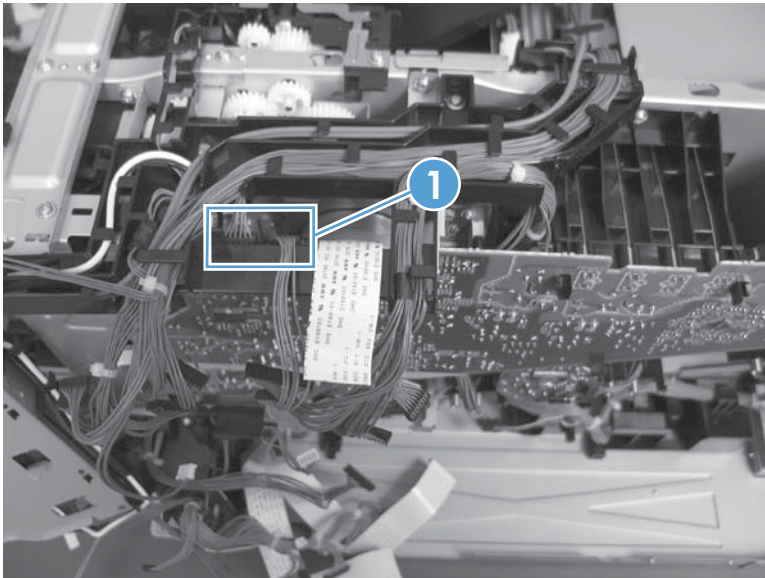
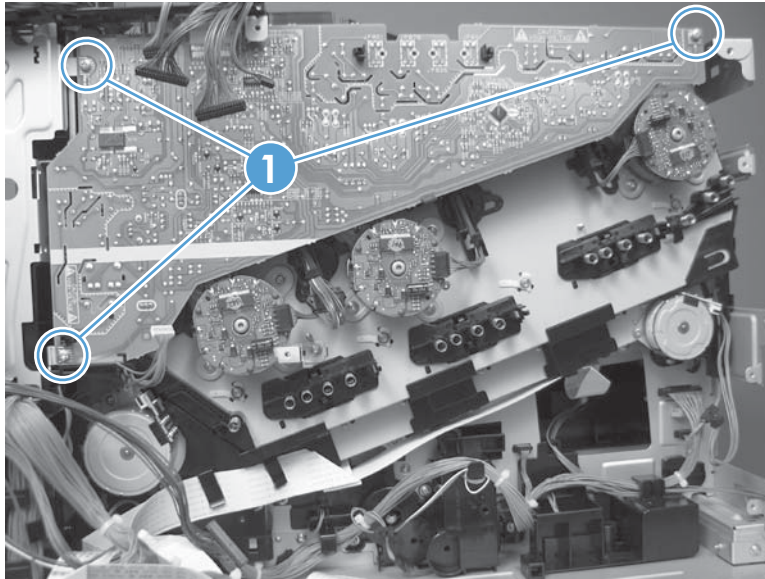

5. Release four tabs (callout 1), and then remove the power supply.

Figure 1-329 Remove the high-voltage power supply upper (5 of 5)

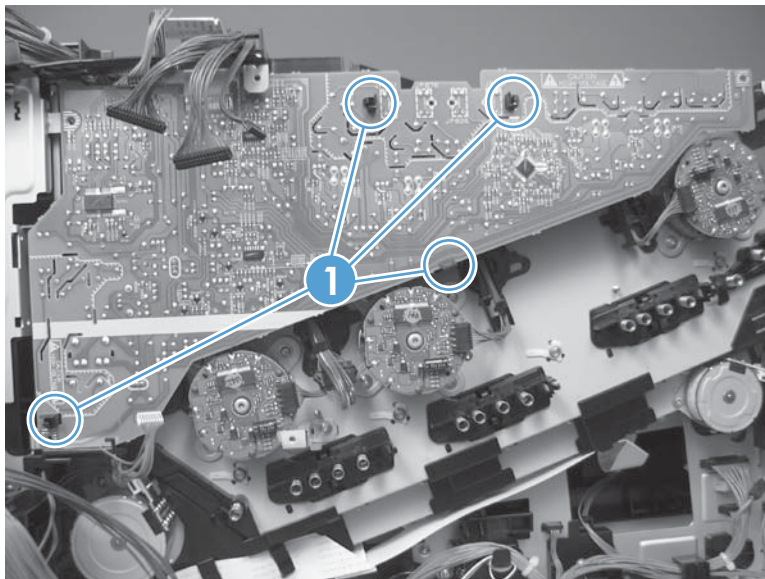

Reinstall the high-voltage power supply upper

When you reinstall the power supply, look through the holes in the PCA and make sure that the high-voltage contact springs are correctly seated against the PCA.

 **NOTE:** One wire harness (callout 1) is disconnected at both ends. Do not lose the wire harness.

Position the FFC (callout 2) *over* the cable guide when you reinstall the power supply.

Figure 1-330 Reinstall the high-voltage power supply upper

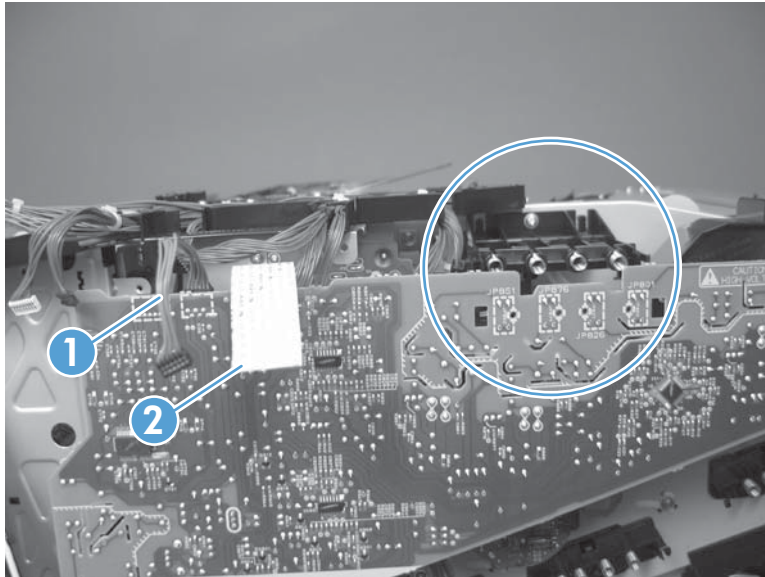

Drum motor 1

Before proceeding, remove the following components:

- Toner-collection unit. See [Toner-collection unit on page 15](#).
- Right-rear cover. See [Right-rear cover on page 90](#).
- Left cover. See [Left cover on page 92](#).
- Rear-upper cover. See [Rear-upper cover on page 95](#).
- Rear cover. See [Rear cover on page 98](#).
- Interconnect board (ICB). See [Interconnect board \(ICB\) on page 148](#).
- DC controller. See [DC controller PCA and tray on page 150](#).
- Low-voltage power supply (LVPS). See [Low-voltage power supply \(LVPS\) on page 153](#).
- High-voltage power supply upper. See [High-voltage power supply upper on page 221](#).

Remove the drum motor 1

- ▲ Disconnect one connector (callout 1), remove four screws (callout 2), and then remove the motor.

Figure 1-331 Remove the drum motor 1

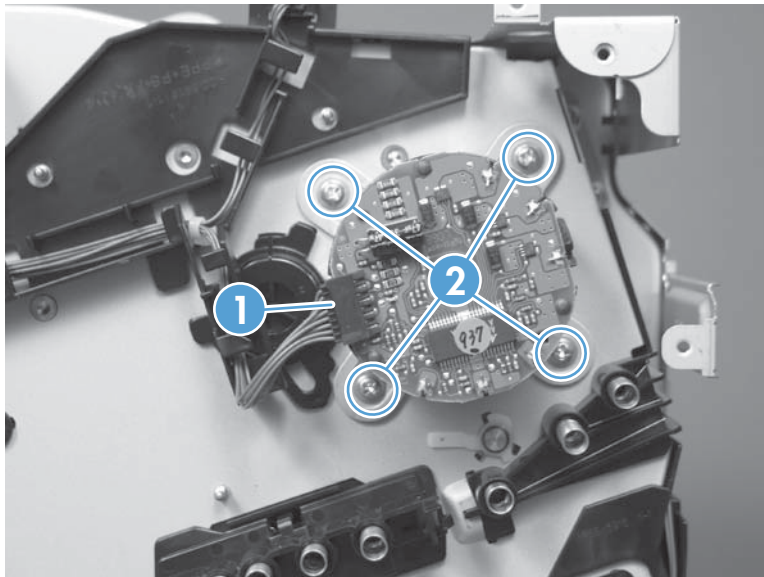

Drum motor 2 or drum motor 3

Before proceeding, remove the following components:

- Toner-collection unit. See [Toner-collection unit on page 15](#).
- Right-rear cover. See [Right-rear cover on page 90](#).
- Left cover. See [Left cover on page 92](#).
- Rear-upper cover. See [Rear-upper cover on page 95](#).
- Rear cover. See [Rear cover on page 98](#).
- Interconnect board (ICB). See [Interconnect board \(ICB\) on page 148](#).
- DC controller. See [DC controller PCA and tray on page 150](#).
- Low-voltage power supply (LVPS). See [Low-voltage power supply \(LVPS\) on page 153](#).
- High-voltage power supply upper. See [High-voltage power supply upper on page 221](#).

Remove the drum motor 2 or drum motor 3

▲ Do one of the following:

- Remove drum motor 2: Disconnect one connector (callout 1), remove four screws (callout 2), and then remove the motor.
- Remove drum motor 3: Disconnect one connector (callout 3), remove four screws (callout 4), and then remove the motor.

Figure 1-332 Remove the drum motor 2 or drum motor 3

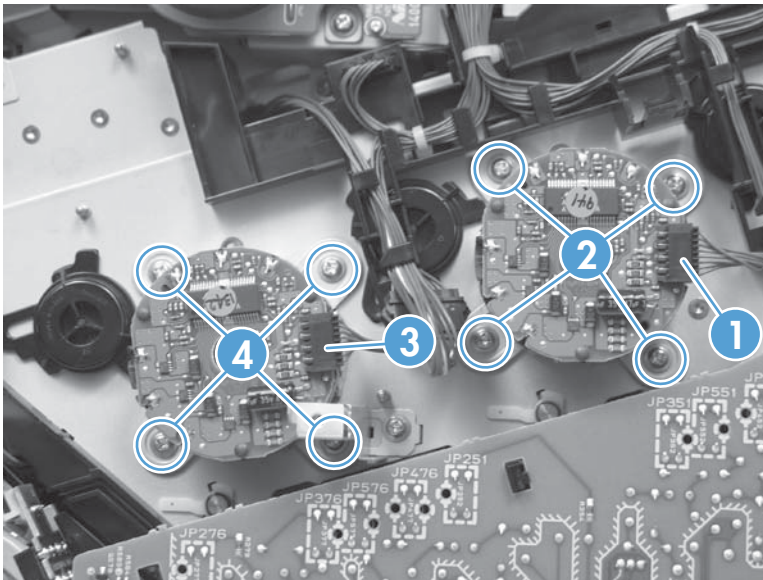

Fuser motor

Before proceeding, remove the following components:

- Toner-collection unit. See [Toner-collection unit on page 15](#).
- Formatter PCA. See [Formatter PCA on page 17](#).
- Right-rear cover. See [Right-rear cover on page 90](#).
- Left cover. See [Left cover on page 92](#).
- Rear-upper cover. See [Rear-upper cover on page 95](#).
- Rear cover. See [Rear cover on page 98](#).
- Interconnect board (ICB). See [Interconnect board \(ICB\) on page 148](#).
- DC controller. See [DC controller PCA and tray on page 150](#).
- Low-voltage power supply (LVPS). See [Low-voltage power supply \(LVPS\) on page 153](#).
- High-voltage power supply upper. See [High-voltage power supply upper on page 221](#).

Remove the fuser motor

Disconnect one connector (callout 1), remove three screws (callout 2), and then remove the motor.

Figure 1-333 Remove the fuser motor

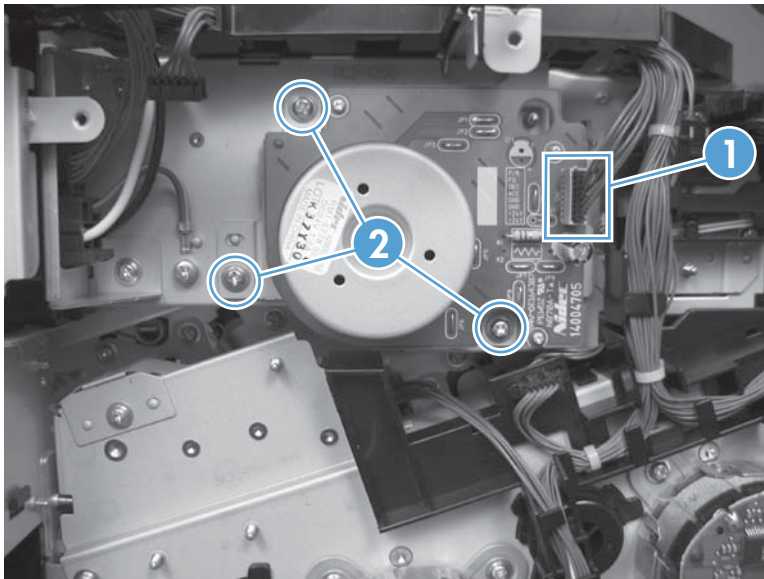

Main-drive assembly

Before proceeding, remove the following components:

- Toner-collection unit. See [Toner-collection unit on page 15](#).
- Formatter PCA. See [Formatter PCA on page 17](#).
- Fuser. See [Fuser on page 24](#).
- Intermediate transfer belt (ITB). See [Intermediate transfer belt \(ITB\) on page 34](#).
- Front-upper cover. See [Front-upper cover on page 83](#).
- Right-rear cover. See [Right-rear cover on page 90](#).
- Left cover. See [Left cover on page 92](#).
- Rear-upper cover. See [Rear-upper cover on page 95](#).
- Left-upper cover. See [Left-upper cover on page 97](#).
- Rear cover. See [Rear cover on page 98](#).
- Front-top cover. See [Front-top cover on page 110](#).
- Rear-top cover. See [Rear-top cover on page 112](#).
- Document feeder. See [Document feeder whole unit on page 127](#).
- Image scanner. See [Image scanner whole unit on page 139](#).
- Interconnect board (ICB). See [Interconnect board \(ICB\) on page 148](#).
- DC controller. See [DC controller PCA and tray on page 150](#).
- Low-voltage power supply (LVPS). See [Low-voltage power supply \(LVPS\) on page 153](#).
- Secondary transfer assembly. See [Secondary transfer assembly on page 171](#).
- Power-supply fan and fan duct. See [Power-supply fan and fan duct on page 181](#).
- High-voltage power supply lower. See [High-voltage power supply lower on page 189](#).
- High-voltage power supply upper. See [High-voltage power supply upper on page 221](#).

Remove the main-drive assembly

1. Remove two screws (callout 1), and then remove the cover (callout 2).

Figure 1-334 Remove the main-drive assembly (1 of 7)

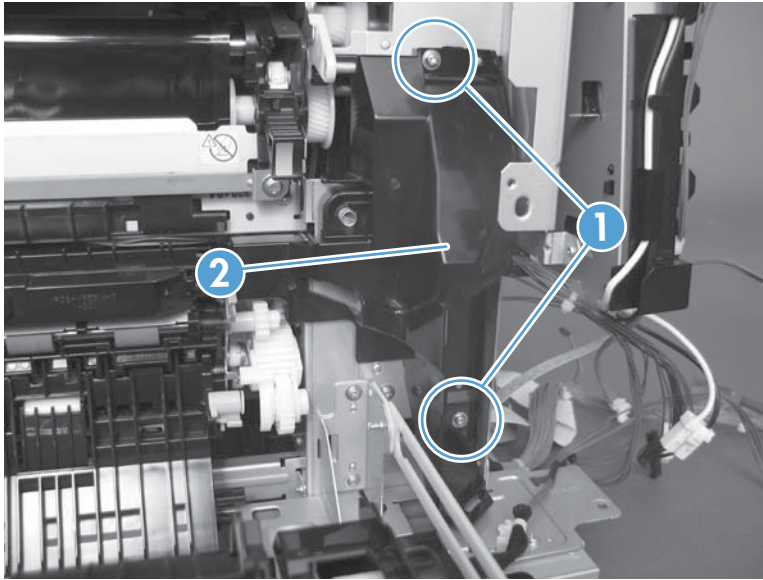

2. Release the wire harnesses from the guide (callout 1), and then remove one screw (callout 2).

Figure 1-335 Remove the main-drive assembly (2 of 7)

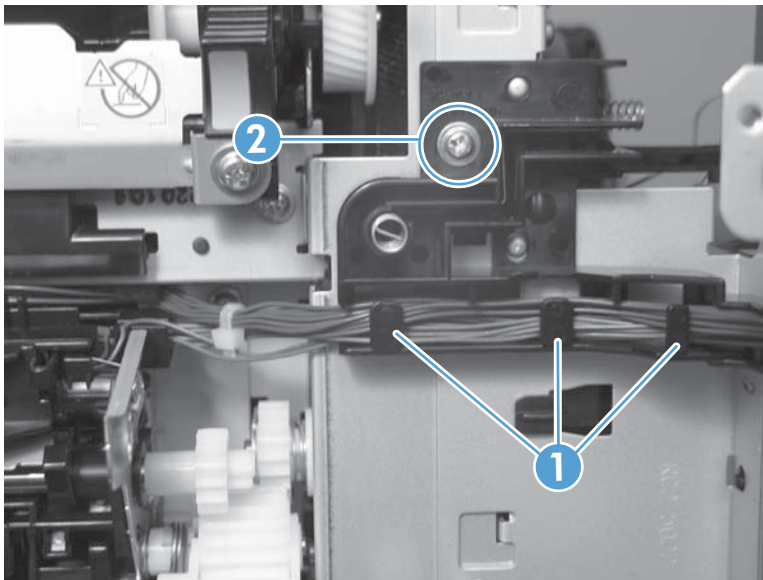

3. Lift the high-voltage bracket up to release it, and then remove the bracket.

Figure 1-336 Remove the main-drive assembly (3 of 7)

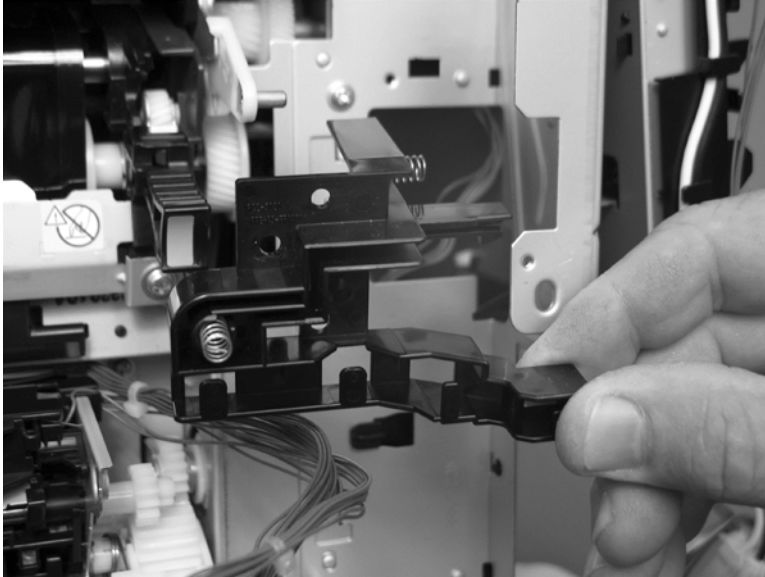

4. Disconnect seven connectors (callout 1), and then release the wire harnesses from the guides.

Figure 1-337 Remove the main-drive assembly (4 of 7)

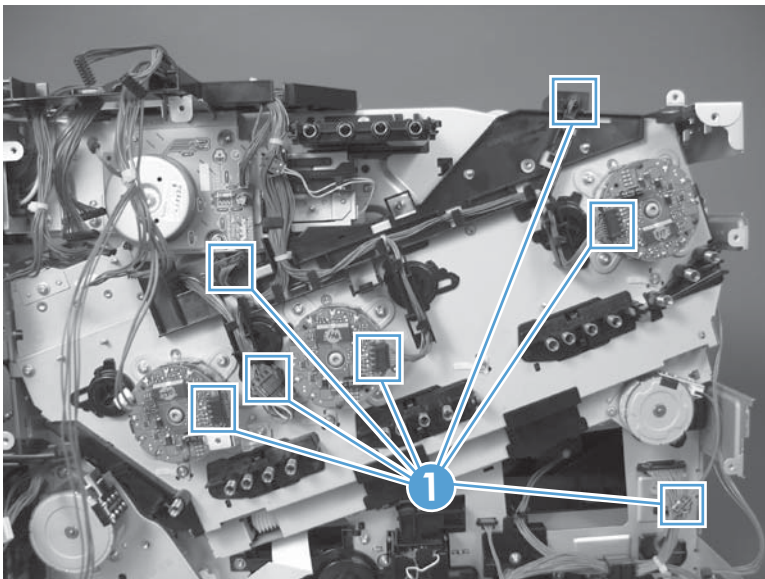

5. Remove two screws (callout 1), and then remove the sheet-metal plates (callout 2).

Figure 1-338 Remove the main-drive assembly (5 of 7)

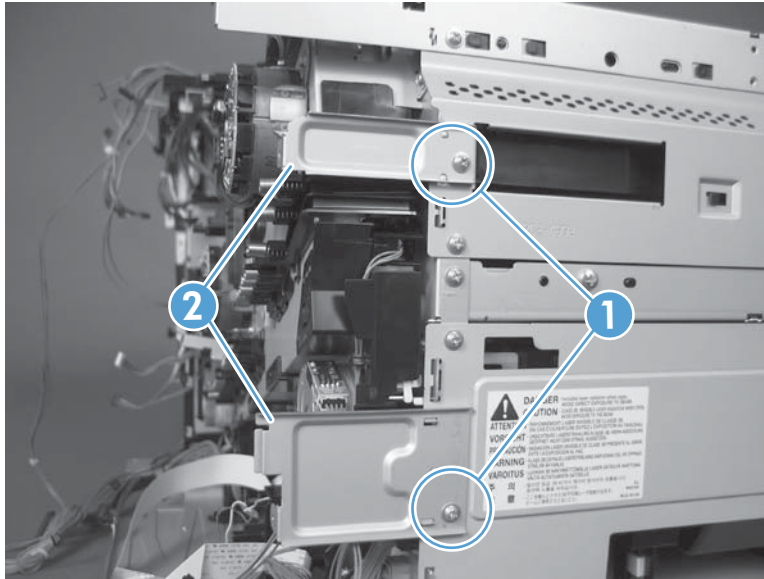

6. Release the FFCs and lower wiring harness from the guide, and then release one tab (callout 1) and remove the guide.

Figure 1-339 Remove the main-drive assembly (6 of 7)

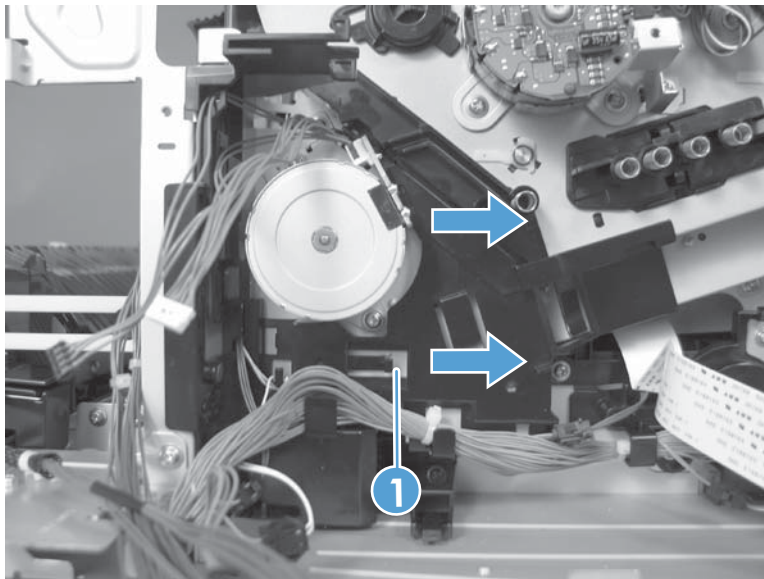

7. Remove ten screws (callout 1), and then carefully remove the assembly.

⚠ CAUTION: Be careful when you remove the assembly. The cams on the backside of the assembly can be dislodged. If the cams become dislodged, install them on the shafts as shown in [Figure 1-342 Reinstall the main-drive assembly \(2 of 11\) on page 233](#).

The black cam must be installed on the shaft furthest away from the developing-disengagement motor. The white cams are interchangeable.

Figure 1-340 Remove the main-drive assembly (7 of 7)

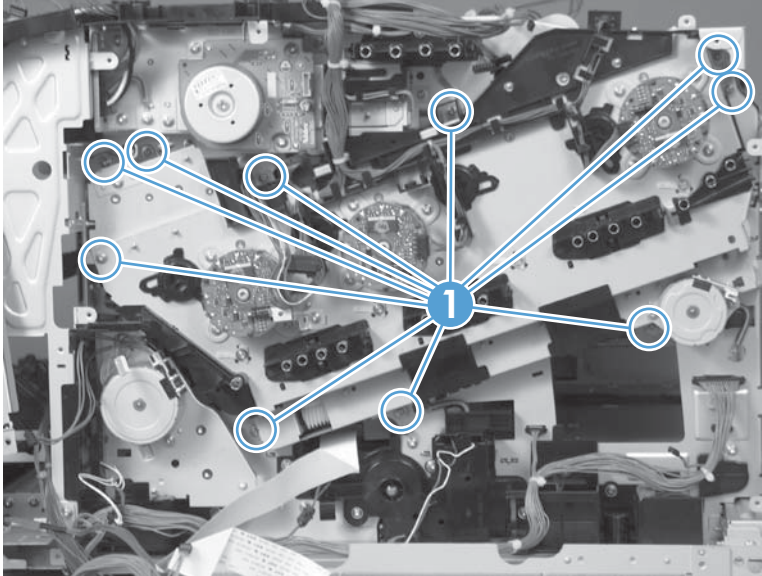

Reinstall the main-drive assembly

1. Remove the bracket (callout 1), two guides (callout 2), and the developing-disengagement motor (callout 3).

Install the bracket and guides on the replacement main-drive assembly.

 **NOTE:** Do not install the developing-disengagement motor on the assembly (this motor must be removed from the assembly to align the main-drive cams).

Figure 1-341 Reinstall the main-drive assembly (1 of 11)



2. Locate the cams (callout 1) on the back side of the assembly.

Figure 1-342 Reinstall the main-drive assembly (2 of 11)

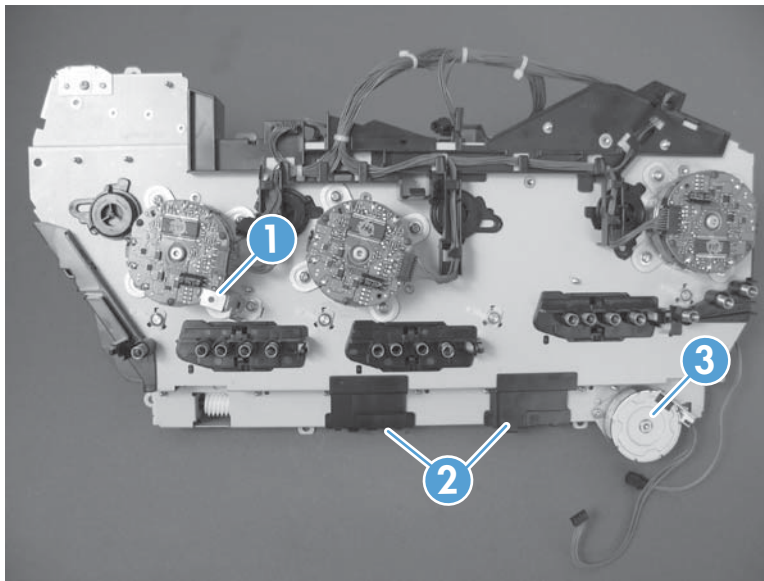
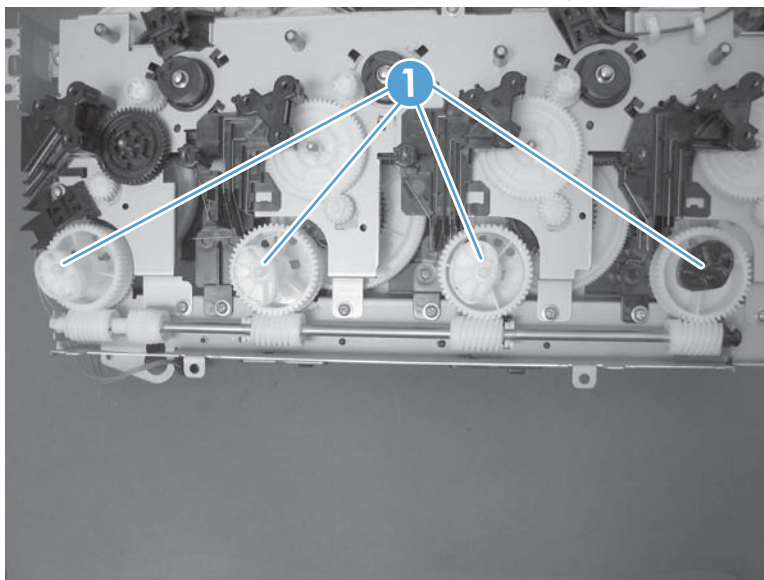

3. Slowly rotate the shaft near the black cam.

⚠ WARNING! Do not touch the plastic gears or cams. You must not wipe away any of the grease that is applied to these components. Always rotate the gears and cams by rotating the metal drive shaft.

Figure 1-343 Reinstall the main-drive assembly (3 of 11)

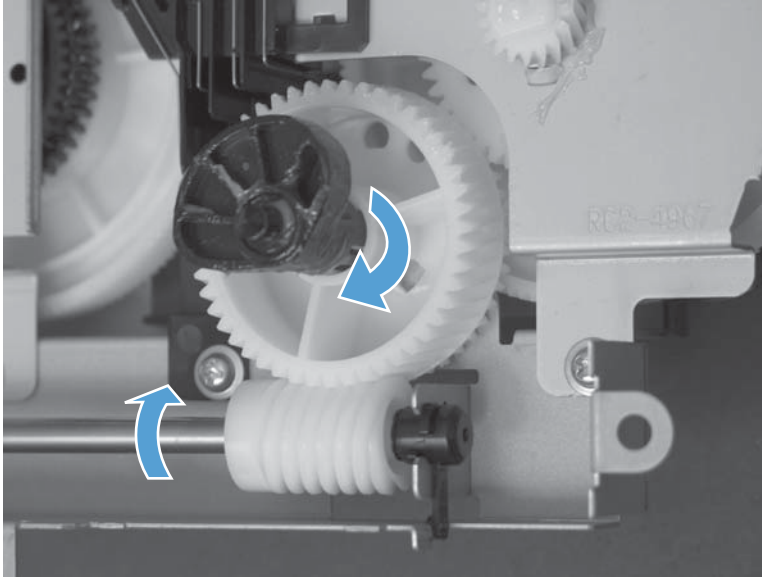

4. Continue to rotate the shaft until the holes in the black-cam gear align as shown below.

When correctly aligned, the *bottom-most* hole in the gear is aligned with a hole in the sheet-metal chassis.

📝 NOTE: The holes in the other cam gears have a different alignment. You must make sure that the holes in the black-cam gear are correctly aligned.

Figure 1-344 Reinstall the main-drive assembly (4 of 11)

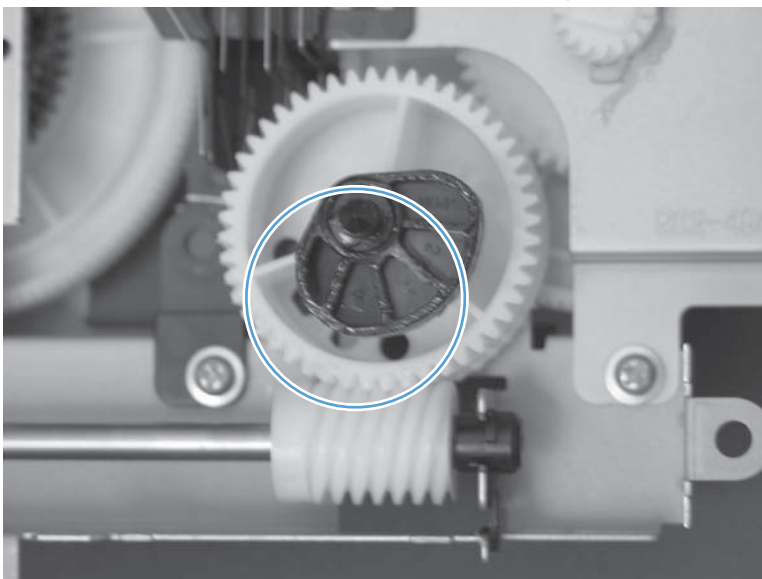

5. Verify that the cams (callout 1) align correctly.

 **TIP:** The second cam in from the right (the white cam to the left of the black cam), should have the *second* hole aligned with the hole in the sheet-metal chassis.

The third cam in from the right, should have the *third* hole aligned with the hole in the sheet-metal chassis.

The fourth cam in from the right (the cam nearest the developing-disengagement motor), should have the *fourth* hole aligned with the hole in the sheet-metal chassis.

If the second, third, or fourth cams do not correctly align, do the following. Hold the long drive shaft, gently tilt the cam and gear away from the shaft to allow clearance to rotate the gear until the correct hole in the gear aligns with the hole in the chassis.

Figure 1-345 Reinstall the main-drive assembly (5 of 11)

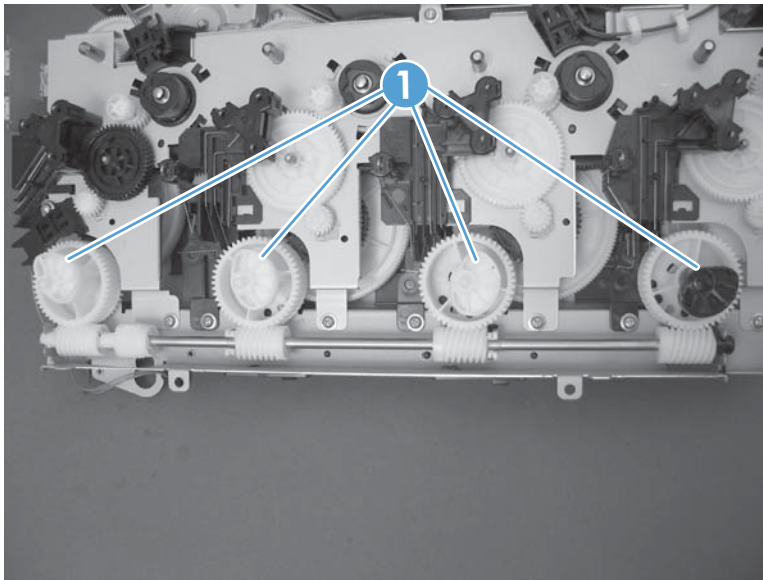

6. When the cams align correctly, they easily fit into the holes in the chassis.

Figure 1-346 Reinstall the main-drive assembly (6 of 11)

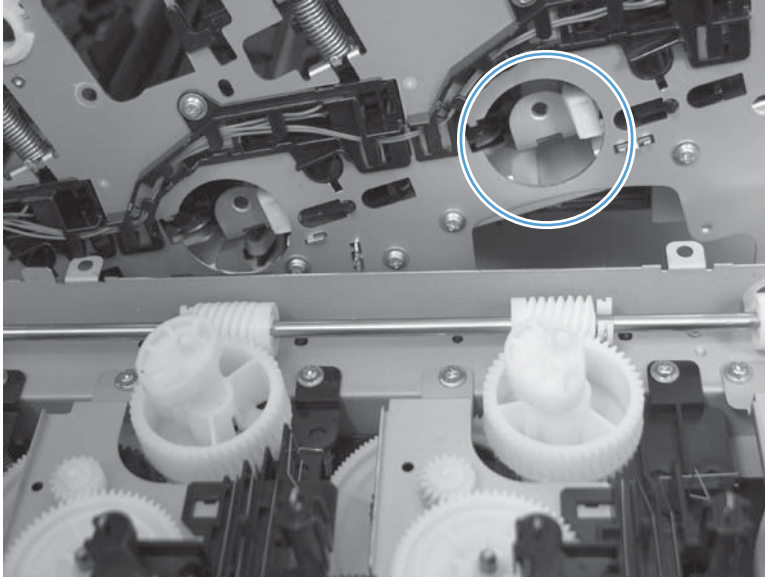

7. When the assembly is placed on the chassis, the pin on the swing gear and on the bracket (callout 1), must align with the holes in the chassis (callout 2).

Figure 1-347 Reinstall the main-drive assembly (7 of 11)

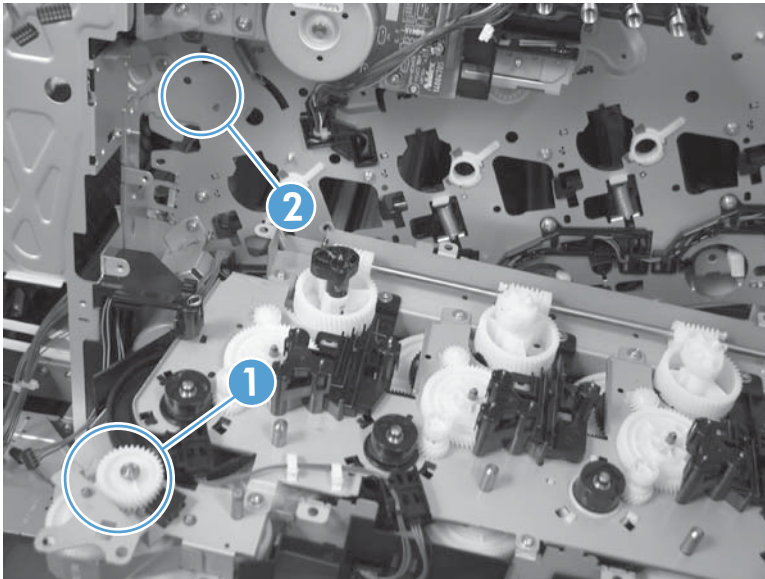

8. Position the assembly on the chassis.

Figure 1-348 Reinstall the main-drive assembly (8 of 11)

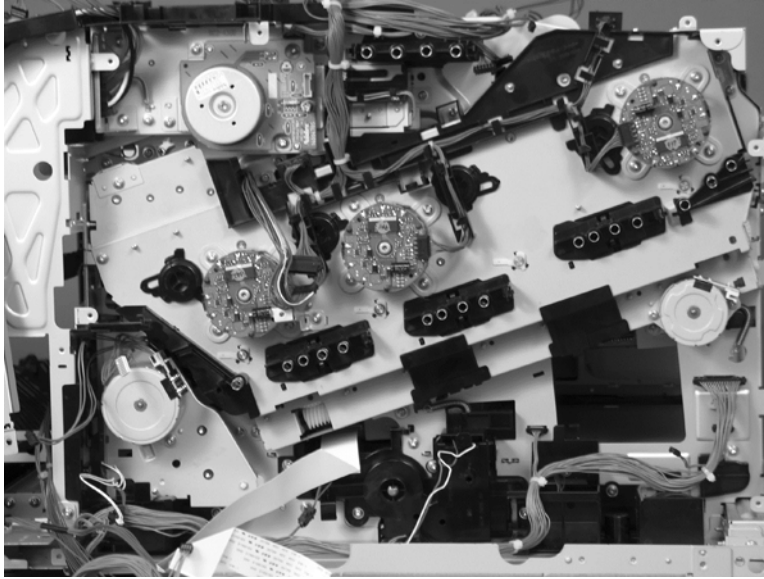

9. Use your finger to push in on the assembly, and use a small flat blade screwdriver to align the pin on the swing gear with the hole in the chassis.

Figure 1-349 Reinstall the main-drive assembly (9 of 11)

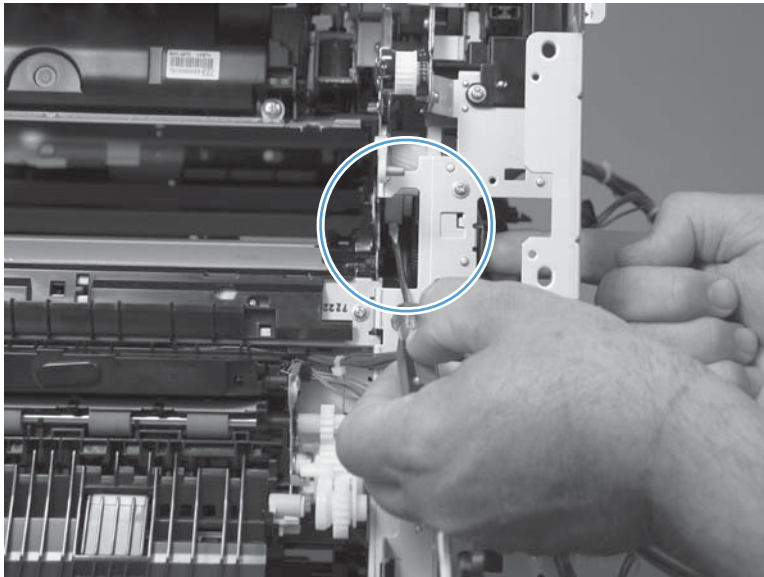

10. When the assembly is correctly installed against the chassis, the pin above the swing gear protrudes through the hole in the chassis.

Figure 1-350 Reinstall the main-drive assembly (10 of 11)

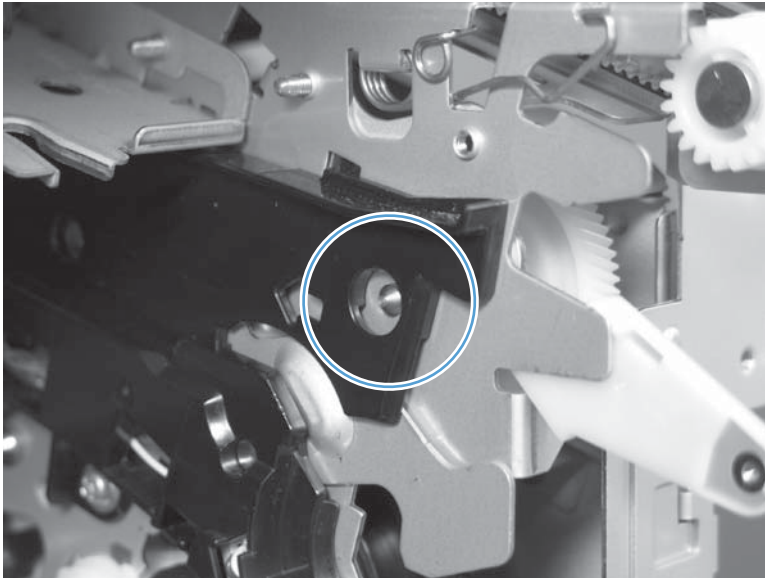

11. Install the main-drive assembly mounting screws, and then reinstall the developing-disengagement motor (callout 1).

 **TIP:** After reassembling the product, print a [Color Band Test](#) page.

If the test page shows one or more color planes are not printing (usually in the upper left corner of the page), the cam or cams for the missing color plane are not correctly aligned. Repeat the reinstall the main-drive assembly procedure.

Figure 1-351 Reinstall the main-drive assembly (11 of 11)

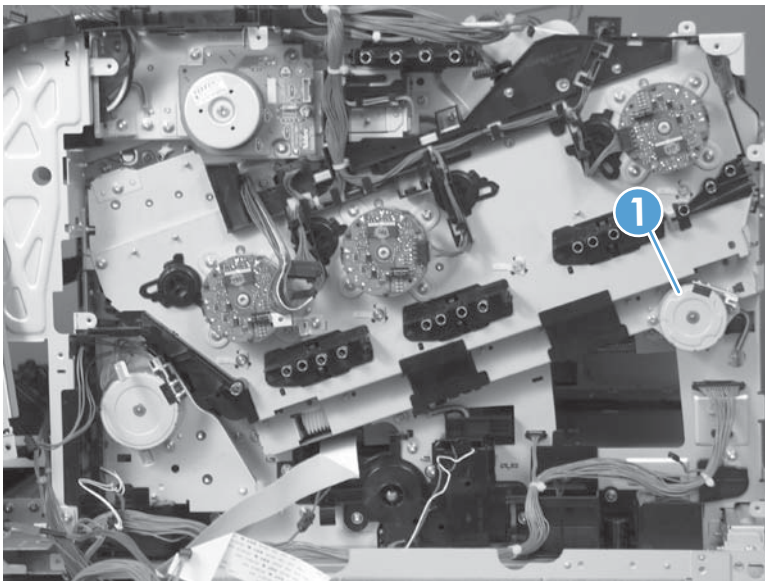

Fuser-drive assembly

Before proceeding, remove the following components:

- Toner-collection unit. See [Toner-collection unit on page 15](#).
- Formatter PCA. See [Formatter PCA on page 17](#).
- Fuser. See [Fuser on page 24](#).
- Intermediate transfer belt (ITB). See [Intermediate transfer belt \(ITB\) on page 34](#).
- Front-upper cover. See [Front-upper cover on page 83](#).
- Stapler cover. See [Stapler cover on page 85](#).
- Right-rear cover. See [Right-rear cover on page 90](#).
- Left-upper cover. See [Left-upper cover on page 97](#).
- Rear-upper cover. See [Rear-upper cover on page 95](#).
- Left-upper cover. See [Left-upper cover on page 97](#).
- Rear cover. See [Rear cover on page 98](#).
- Front-top cover. See [Front-top cover on page 110](#).
- Rear-top cover. See [Rear-top cover on page 112](#).
- Document feeder whole unit. See [Document feeder whole unit on page 127](#).
 - See [Document feeder whole unit on page 127](#).
 - See [Document feeder whole unit \(M575c model\) on page 130](#).
- Scanner-control board (SCB).
 - See [Scanner-control board \(SCB\) on page 133](#).
 - See [Scanner-control board \(SCB; M575c\) on page 136](#).
- Image scanner whole unit. See [Image scanner whole unit on page 139](#).
- Interconnect board (ICB). See [Interconnect board \(ICB\) on page 148](#).
- DC controller. See [DC controller PCA and tray on page 150](#).
- Low-voltage power supply (LVPS). See [Low-voltage power supply \(LVPS\) on page 153](#).
- Secondary transfer assembly. See [Secondary transfer assembly on page 171](#).
- Power-supply fan and fan duct. See [Power-supply fan and fan duct on page 181](#).
- High-voltage power supply lower. See [High-voltage power supply lower on page 189](#).

- High-voltage power supply upper. See [High-voltage power supply upper on page 221](#).
- Main-drive assembly. See [Main-drive assembly on page 228](#).

Remove the fuser-drive assembly

1. Disconnect one connector (callout 1), and then release the wire harnesses from the guide (callout 2).

Figure 1-352 Remove the fuser-drive assembly (1 of 6)

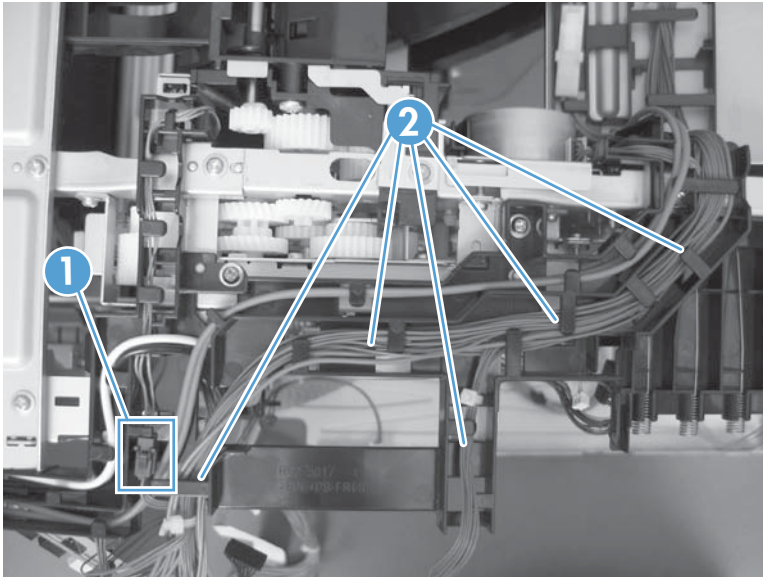

2. Remove two screws (callout 1), and then remove the guide (callout 2).

Figure 1-353 Remove the fuser-drive assembly (2 of 6)

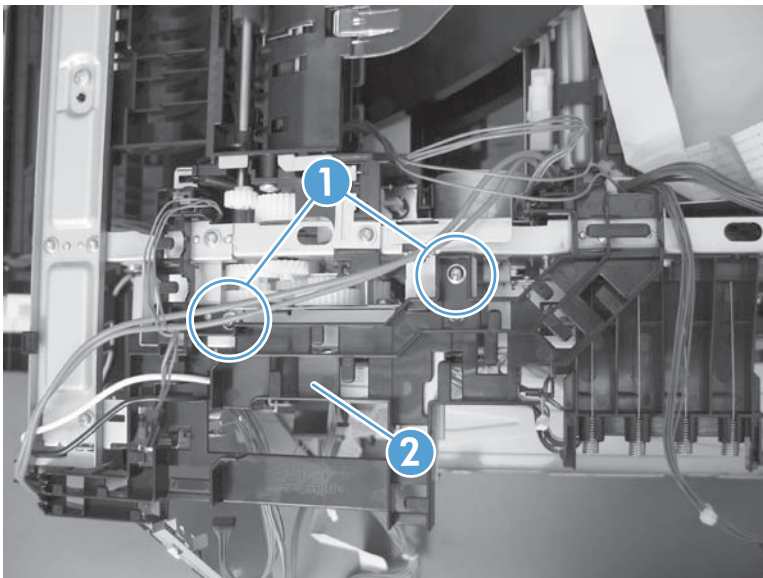

3. Remove one screw (callout 1), and then remove the sheet-metal plate (callout 2).

Figure 1-354 Remove the fuser-drive assembly (3 of 6)

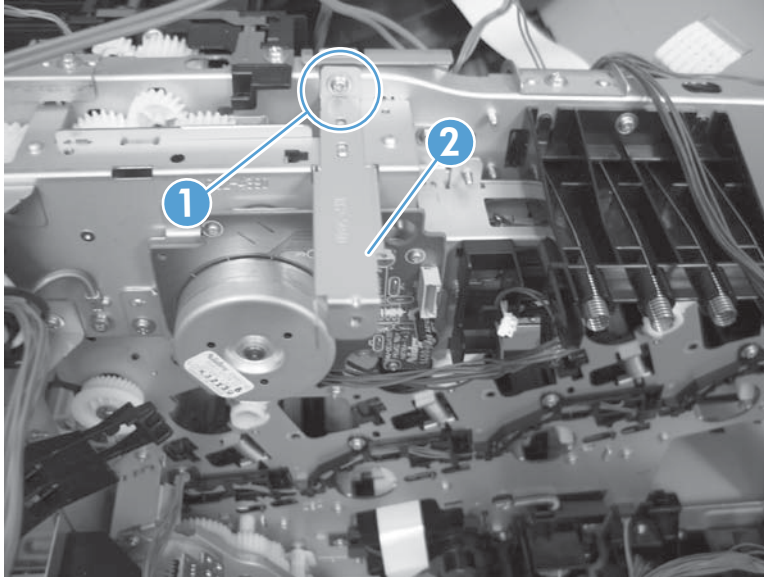

4. Remove one screw (callout 1), and then remove the cover (callout 2).

Figure 1-355 Remove the fuser-drive assembly (4 of 6)

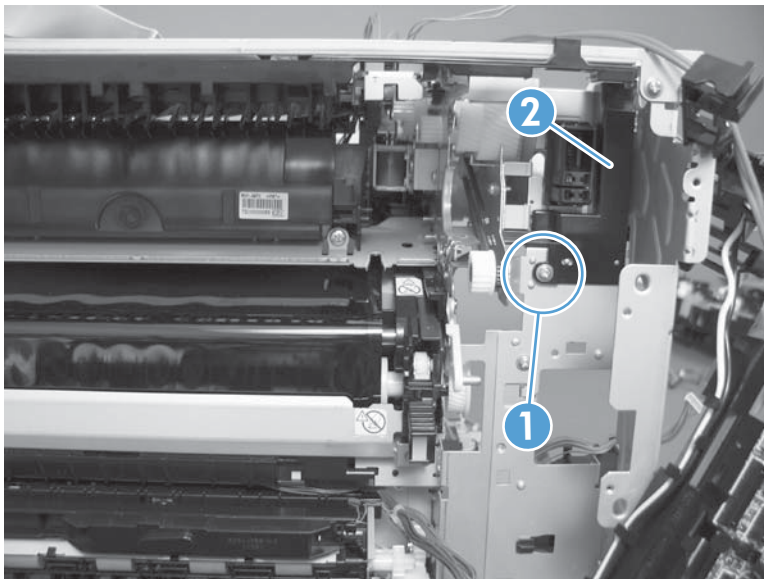

5. Remove five screws (callout 1).

Figure 1-356 Remove the fuser-drive assembly (5 of 6)

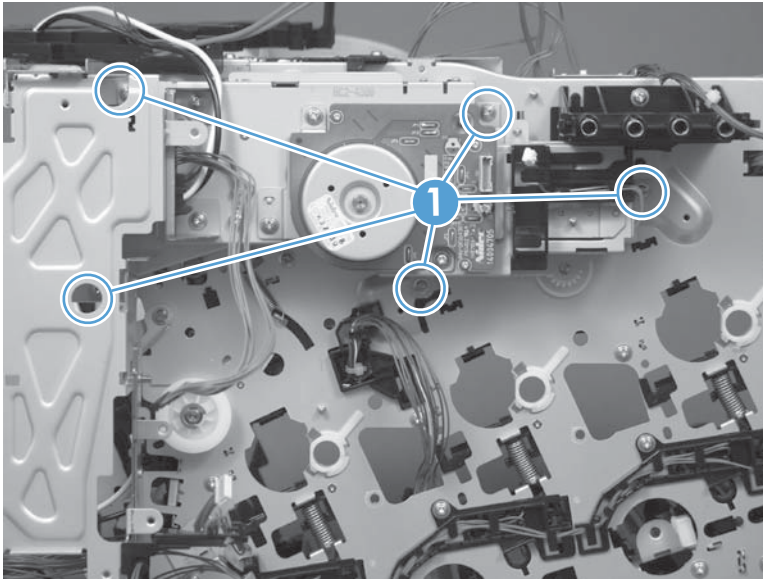

6. Carefully remove the assembly.

⚠ CAUTION: A gear on the assembly is not captive. Do not lose the gear when you remove the assembly. If the gear becomes dislodged, see [Reinstall the fuser-drive assembly on page 243](#).

Figure 1-357 Remove the fuser-drive assembly (6 of 6)

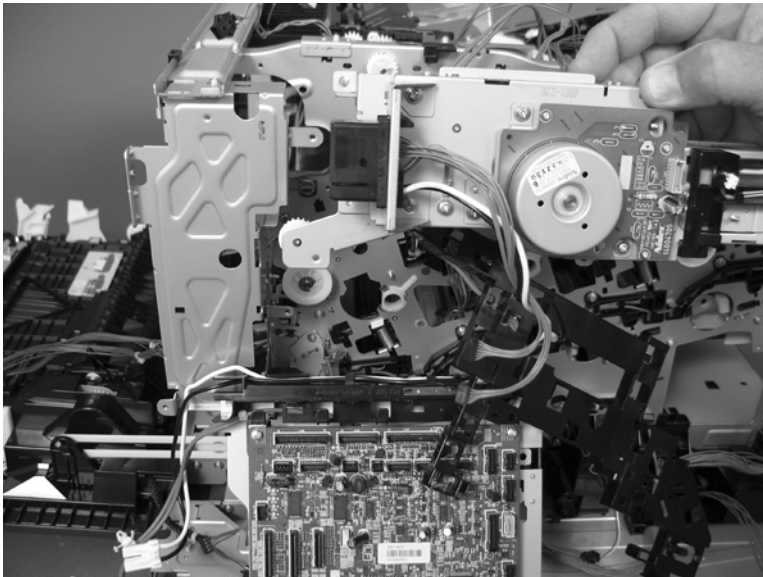

Reinstall the fuser-drive assembly

If the gear (callout 1) is dislodged when the assembly is removed, use the figure below to correctly install it on the assembly.

Figure 1-358 Reinstall the fuser-drive assembly

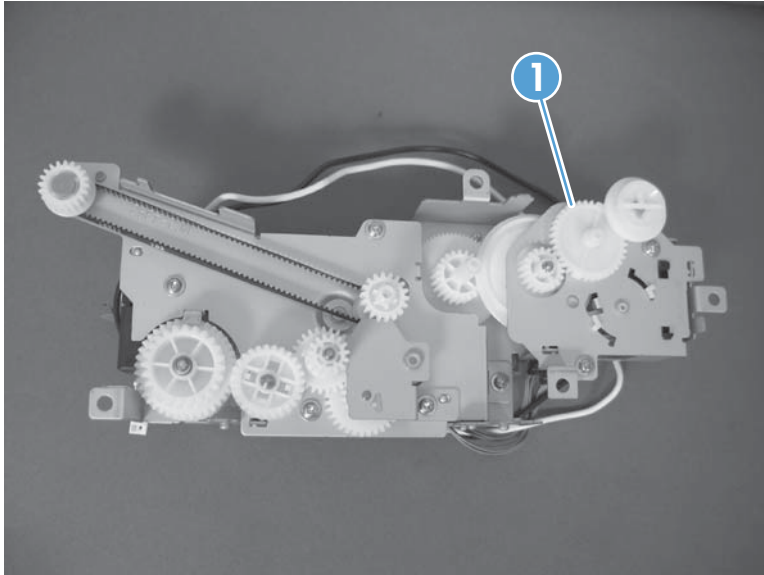

Delivery assembly

Before proceeding, remove the following components:

- Toner-collection unit. See [Toner-collection unit on page 15](#).
- Formatter PCA. See [Formatter PCA on page 17](#).
- Fuser. See [Fuser on page 24](#).
- Intermediate transfer belt (ITB). See [Intermediate transfer belt \(ITB\) on page 34](#).
- Front-upper cover. See [Front-upper cover on page 83](#).
- Left-upper cover. See [Left-upper cover on page 97](#).
- Right-rear cover. See [Right-rear cover on page 90](#).
- Left cover. See [Left cover on page 92](#).
- Stapler cover. See [Stapler cover on page 85](#).
- Rear-upper cover. See [Rear-upper cover on page 95](#).
- Rear cover. See [Rear cover on page 98](#).
- Front-top cover. See [Front-top cover on page 110](#).
- Rear-top cover. See [Rear-top cover on page 112](#).
- Document feeder whole unit.
 - See [Document feeder whole unit on page 127](#).
 - See [Document feeder whole unit \(M575c model\) on page 130](#).
- Scanner-control board (SCB).
 - See [Scanner-control board \(SCB\) on page 133](#).
 - See [Scanner-control board \(SCB; M575c\) on page 136](#).
- Image scanner whole unit. See [Image scanner whole unit on page 139](#).
- Interconnect board (ICB). See [Interconnect board \(ICB\) on page 148](#).
- DC controller. See [DC controller PCA and tray on page 150](#).
- Low-voltage power supply (LVPS). See [Low-voltage power supply \(LVPS\) on page 153](#).
- Secondary transfer assembly. See [Secondary transfer assembly on page 171](#).
- Power-supply fan and fan duct. See [Power-supply fan and fan duct on page 181](#).
- High-voltage power supply lower. See [High-voltage power supply lower on page 189](#).
- High-voltage power supply upper. See [High-voltage power supply upper on page 221](#).

- Main-drive assembly. See [Main-drive assembly on page 228](#).
- Fuser-drive assembly. See [Fuser-drive assembly on page 239](#).

Remove the delivery assembly

1. Remove two screws (callout 1), and then remove the guide (callout 2).

Figure 1-359 Remove the delivery assembly (1 of 5)

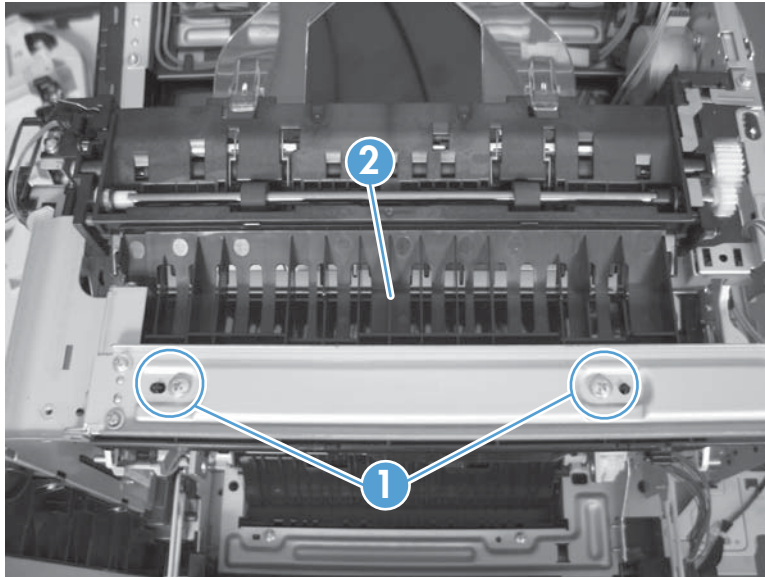

2. Remove two screws (callout 1).

Figure 1-360 Remove the delivery assembly (2 of 5)

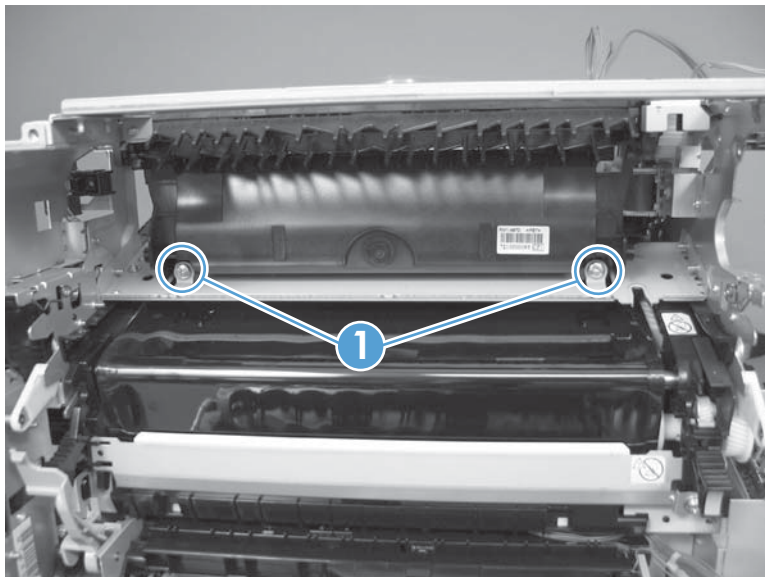

3. Release one tab (callout 1), and then remove the gear (callout 2).

Figure 1-361 Remove the delivery assembly (3 of 5)

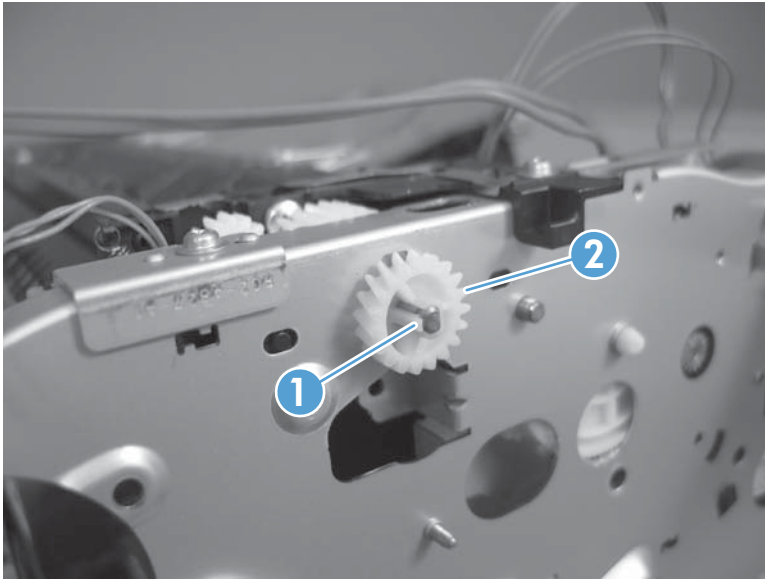

4. Release one tab (callout 1), and then rotate the locking clip until the tab on the clip aligns with the slot in the chassis.

Figure 1-362 Remove the delivery assembly (4 of 5)

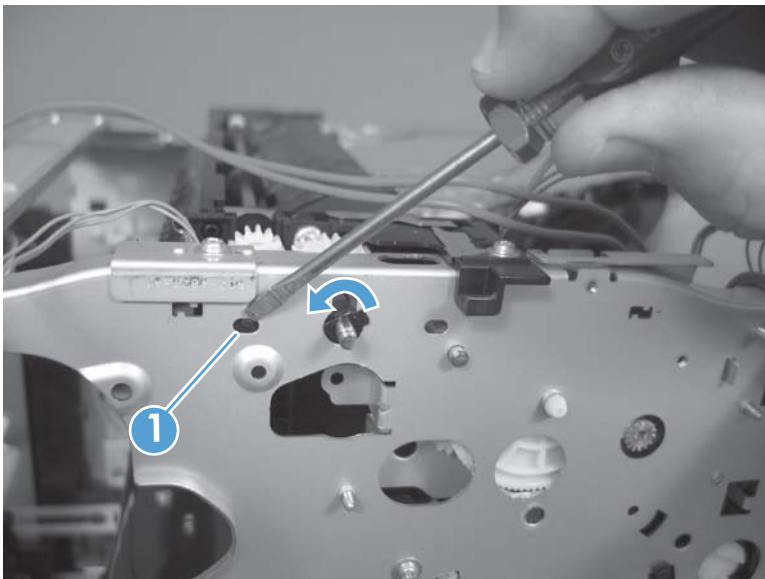

5. Disconnect one connector (callout 1), remove two screws (callout 2), and then carefully lift the assembly (callout 3) off of the product to remove it.

⚠ CAUTION: A solenoid arm (on the right side) and a spring (on the left side) on the assembly are not captive. Do not lose the solenoid arm or spring when you remove the assembly. If the solenoid arm or spring become dislodged, see [Reinstall the delivery assembly on page 248](#).

Figure 1-363 Remove the delivery assembly (5 of 5)

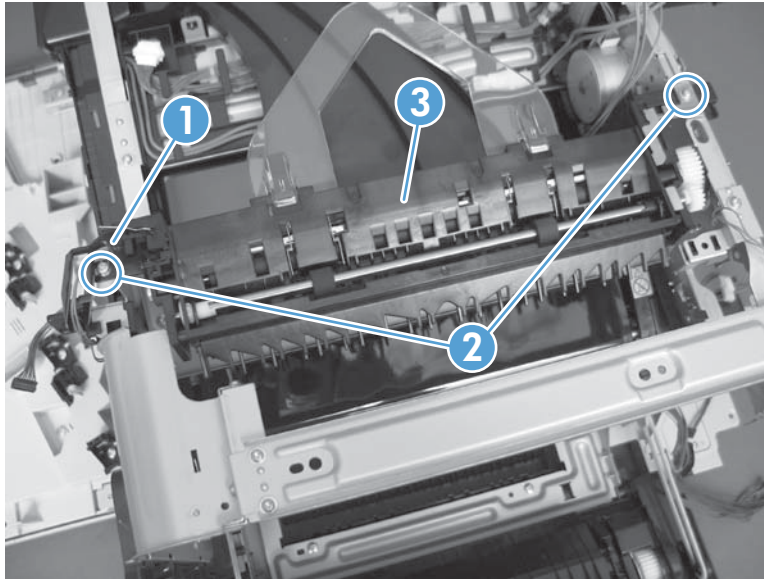

Reinstall the delivery assembly

1. Make sure that the solenoid arm is correctly installed on the assembly.

Figure 1-364 Reinstall the delivery assembly (1 of 2)

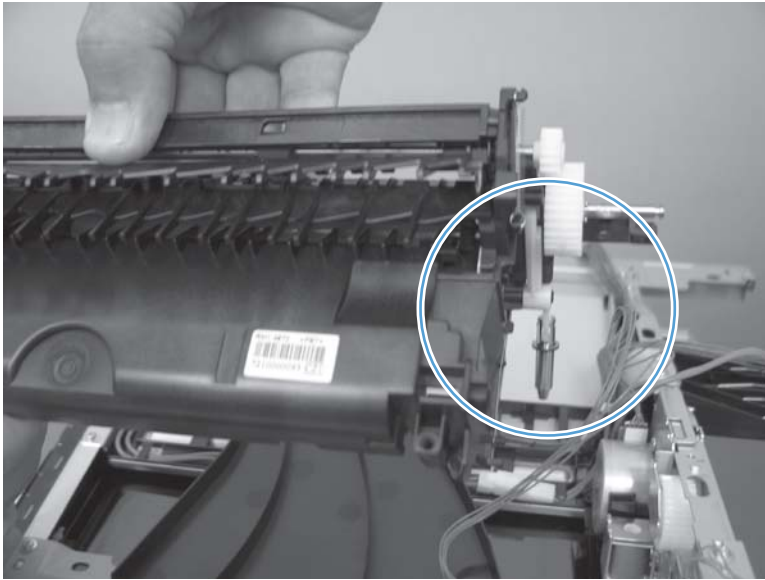

2. Make sure that the spring is correctly installed on the assembly.

Figure 1-365 Reinstall the delivery assembly (2 of 2)

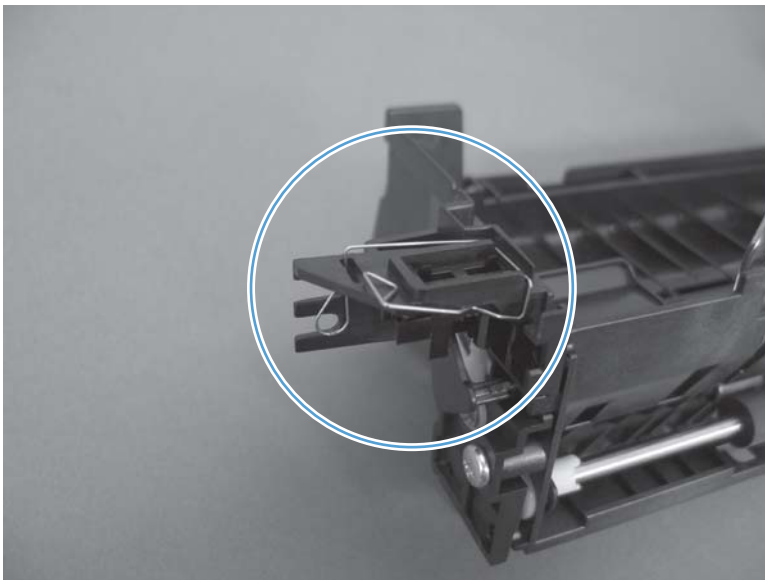

Duplex-drive assembly

Before proceeding, remove the following components:

- Toner-collection unit. See [Toner-collection unit on page 15](#).
- Formatter PCA. See [Formatter PCA on page 17](#).
- Fuser. See [Fuser on page 24](#).
- Intermediate transfer belt (ITB). See [Intermediate transfer belt \(ITB\) on page 34](#).
- Front-upper cover. See [Front-upper cover on page 83](#).
- Stapler cover. See [Stapler cover on page 85](#).
- Right-rear cover. See [Right-rear cover on page 90](#).
- Left cover. See [Left cover on page 92](#).
- Rear-upper cover. See [Rear-upper cover on page 95](#).
- Left-upper cover. See [Left-upper cover on page 97](#).
- Rear cover. See [Rear cover on page 98](#).
- Front-top cover. See [Front-top cover on page 110](#).
- Rear-top cover. See [Rear-top cover on page 112](#).
- Document feeder whole unit.
 - See [Document feeder whole unit on page 127](#).
 - See [Document feeder whole unit \(M575c model\) on page 130](#).
- Scanner-control board (SCB).
 - See [Scanner-control board \(SCB\) on page 133](#).
 - See [Scanner-control board \(SCB; M575c\) on page 136](#).
- Interconnect board (ICB). See [Interconnect board \(ICB\) on page 148](#).
- DC controller. See [DC controller PCA and tray on page 150](#).
- Low-voltage power supply (LVPS). See [Low-voltage power supply \(LVPS\) on page 153](#).
- Secondary transfer assembly. See [Secondary transfer assembly on page 171](#).
- Power-supply fan and fan duct. See [Power-supply fan and fan duct on page 181](#).
- High-voltage power supply lower. See [High-voltage power supply lower on page 189](#).
- High-voltage power supply upper. See [High-voltage power supply upper on page 221](#).
- Main-drive assembly. See [Main-drive assembly on page 228](#).

- Fuser-drive assembly. See [Fuser-drive assembly on page 239](#).
- Delivery assembly. See [Delivery assembly on page 244](#).

Remove the duplex-drive assembly

1. Disconnect two connectors (callout 1), and then remove three screws (callout 2).

Figure 1-366 Remove the duplex-drive assembly (1 of 2)

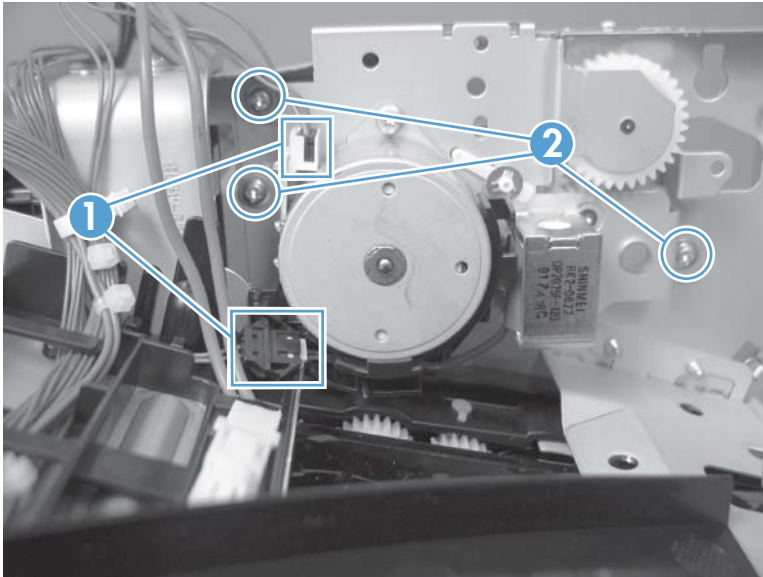

2. Remove the assembly.

Figure 1-367 Remove the duplex-drive assembly (2 of 2)

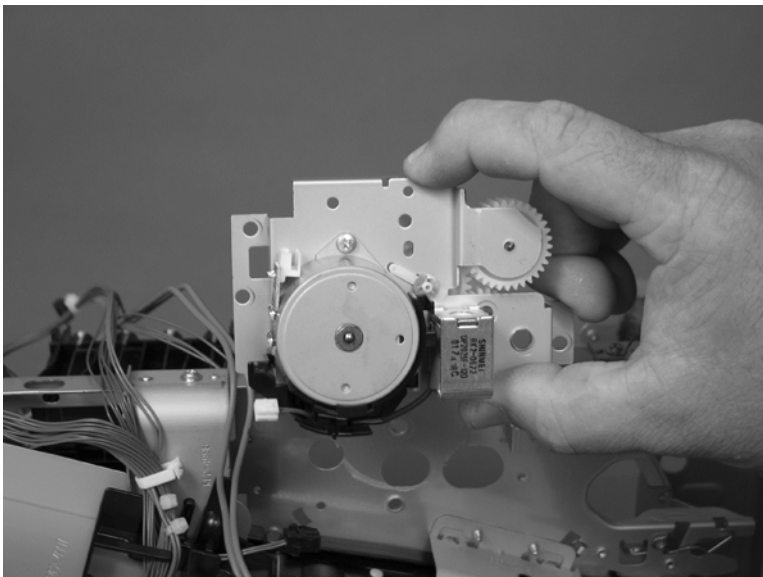

Optional paper feeder assembly (Tray 3)

 **NOTE:** For information about removing the Tray 3 pickup roller, see [Pickup and feed rollers \(Tray 3\) on page 29](#).

For information about removing the Tray 3, see [Tray 2 and 3 on page 23](#).

For information about removing the right door (optional paper feeder), see [Right door \(optional paper feeder\) on page 78](#).

Drawer connector

1. With a small screwdriver, lift one tab and then slide the drawer connector to release.

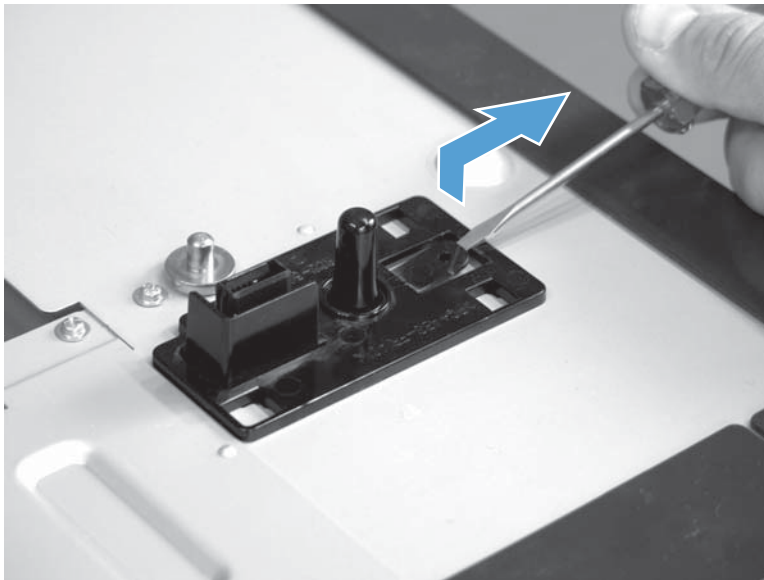

2. Remove one connector (callout 1).

Figure 1-368 Remove the drawer connector; optional paper feeder

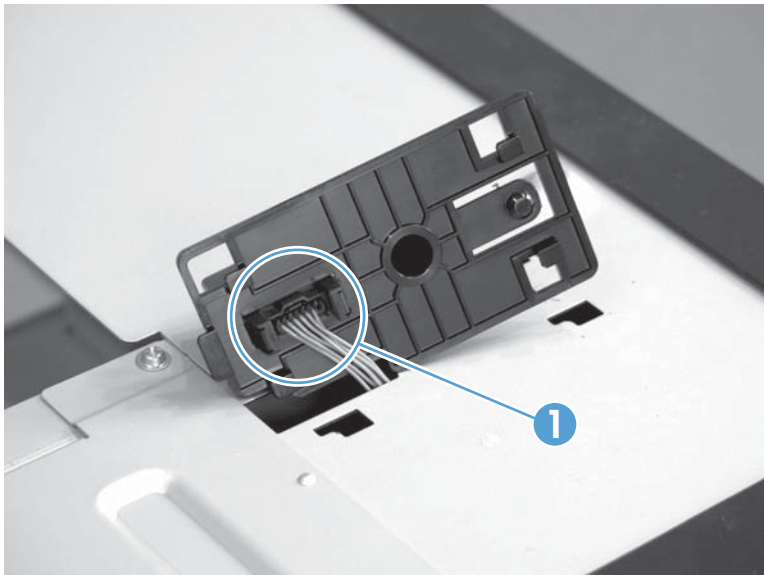

2 Parts and diagrams

- [Order parts, accessories, and supplies](#)
- [Orderable parts](#)
- [Related documentation and software](#)
- [Fasteners used in this product](#)
- [How to use the parts lists and diagrams](#)
- [Assembly locations](#)
- [Covers](#)
- [Document feeder and scanner assemblies \(M575dn and 575f models\)](#)
- [Document feeder and scanner assemblies \(M575c model\)](#)
- [Keyboard \(M575c model\)](#)
- [Control panel assembly](#)
- [ADF assemblies](#)
- [Scanner assemblies](#)
- [Right-door assembly](#)
- [Internal assemblies](#)
- [Assessories](#)
- [Alphabetical parts list](#)
- [Numerical parts list](#)

Order parts, accessories, and supplies

You can obtain the following items directly from HP:

- **Replacement parts:** To order replacement parts in the U.S., go to www.hp.com/go/hpparts/. Outside the United States, order parts by contacting your local authorized HP service center.
- **Supplies and accessories:** To order supplies in the U.S., go to www.hp.com/go/ljsupplies. To order supplies worldwide, go to www.hp.com/ghp/buyonline.html. To order accessories, go to www.hp.com/support/lj500colorMFPM575 and www.hp.com/support/ljcolorflowMFPM575.

Orderable parts

The following list of accessories was current at the time of printing. Ordering information and availability of the accessories might change during the life of the product.

The tables in this section describe customer replaceable repair (CSR) assemblies and service kit assemblies. Use the list below to determine the level of ability required to install a listed assembly.

- **CSR A:** Easy install; minimum technical ability required to install the assembly.
- **CSR B:** Basic install; some technical ability required to install the assembly.
- **CSR N:** Difficult install; maximum technical ability required to install the assembly.

 **NOTE:** CSR N assemblies are not customer replaceable assemblies. These assemblies must be installed by a qualified service technician.

Accessories

Table 2-1 Accessories

Item	Description	Product number	Part number	CSR level
1 x 500-sheet paper feeder		CE084A	CF084-67901	CSR A

Table 2-1 Accessories (continued)

Item	Description	Product number	Part number	CSR level
LaserJet printer cabinet		CE085A	CD644-67917	CSR A
Power cords	PWR-CORD OPT-934 3-COND 1.9-M-LG ROHS		8121-0971	CSR A
	PWR-CORD OPT-902 3-COND 1.9-M-LG ROHS		8121-0950	
	PWR-CORD OPT-922 3-COND 1.9-M-LG ROHS		8121-0945	
	PWR-CORD OPT-901 3-COND 1.9-M-LG ROHS		8121-0872	
	PWR-CORD OPT-918 3-COND 1.9-M-LG ROHS		8121-1144	
	PWR-CORD OPT-919 3-COND 1.9-M-LG ROHS		8121-1005	
	PWR-CORD OPT-912 3-COND 1.9-M-LG ROHS		8121-0949	
	PWR-CORD OPT-923 3-COND 1.9-M-LG ROHS		8121-1083	
	PWR-CORD OPT-917 3-COND 1.9-M-LG ROHS		8121-0954	
	PWR-CORD OPT-900 3-COND 1.9-M-L 10A ROHS		8121-0946	
	PWR-CORD OPT-906 3-COND 1.9-M-LG ROHS		8121-0947	
	PWR-CORD OPT-903 3-COND 1.9-M-LG ROHS		8121-0921	
	PWR-CORD OPT-921 3-COND 1.9-M-LG ROHS		8121-0951	
	PWR-CORD OPT-940 3 COND 1.9-M-LG ROHS		8121-0952	
	PWR-CORD OPT-940 3 COND 1.9-M-LG ROHS		8121-1070	
	PWR-CORD OPT-920 3-COND 1.9-M-LG ROHS		8121-0953	

Print cartridges and toner collection unit

Product name	Cartridge number	Part number (service)	CSR level
HP Color LaserJet standard black print cartridge	CE400A	CE400-67901	CSR A
HP Color LaserJet high capacity black print cartridge	CE400X	CE400-67902	
HP Color LaserJet cyan print cartridge	CE401A	CE401-67901	
HP Color LaserJet yellow print cartridge	CE402A	CE402-67901	
HP Color LaserJet magenta print cartridge	CE403A	CE403-67901	

Product name	Cartridge number	Part number (service)	CSR level
Toner collection unit (TCU)	CE254A	CF081-67903	CSR A
Fuser kit		CD644-67906 (110 V)	CSR A
<ul style="list-style-type: none"> Fuser assembly (110 V or 220 V) Installation instructions Recycle guide 		CD644-67907 (220 V)	

CAUTION: Make sure that you order the correct kit for the rated voltage of your product.

Memory

Product name	Part number	CSR level
Hard drive replacement kit	CD644-67912	CSR B
<ul style="list-style-type: none"> 250 GB HDD Bracket Installation instructions 	NOTE: 575dn and 575f models only.	
HDD Replacement Kit (U.S. government only)	CD644-67913	CSR B
<ul style="list-style-type: none"> 320 GB HDD Bracket Installation instructions 	NOTE: 575dn and 575f models only.	
Hard drive replacement kit	CD646-67905	CSR B
<ul style="list-style-type: none"> 320 GB encrypted HDD Bracket Installation instructions 	NOTE: 575c model only.	

Customer self repair and service kits

The tables in this section describe customer replaceable repair (CSR) assemblies and service kit assemblies. Use the list below to determine the level of ability required to install a listed assembly.

- **CSR A:** Easy install; minimum technical ability required to install the assembly.
- **CSR B:** Basic install; some technical ability required to install the assembly.
- **CSR N:** Difficult install; maximum technical ability required to install the assembly.



NOTE: CSR N assemblies are not customer replaceable assemblies. These assemblies must be installed by a qualified service technician.

Product name	Part number	CSR level
1 x 500-sheet paper feeder right door kit	CC468-67906	CSR A
<ul style="list-style-type: none"> • Right-door assembly • Right-door stopper • Right-door link • Installation instructions 		
1 x 500-sheet paper feeder kit	CF084-67901	CSR A
<ul style="list-style-type: none"> • 1 x 500-sheet paper feeder • Installation instructions 		
ADF open close sensor assembly kit	5851-4846	CSR N
<ul style="list-style-type: none"> • Plunger, ADF open • Spring, ADF open • ADF open sensor • Installation instructions 		
ADF pick success sensor assembly kit	5851-4849	CSR N
<ul style="list-style-type: none"> • Flag pick success • Spring duplex • Installation instructions 		
ADF roller maintenance kit	L2725-60002	CSR A
<ul style="list-style-type: none"> • PM roller kit • Installation instructions 		
ADF whole unit kit	CD644-67918	CSR N
<ul style="list-style-type: none"> • ADF assembly • Foam reflector • Installation instructions 	NOTE: 575dn and 575f models only.	
ADF whole unit kit	CD644-67921	CSR N
<ul style="list-style-type: none"> • ADF assembly • Foam reflector • Installation instructions 	NOTE: 575c models only.	

Product name	Part number	CSR level
ADF width adjustor kit <ul style="list-style-type: none"> • Width adjustor guide, rear • Width adjustor guide, front • Width adjustor slider guide • Installation instructions 	5851-4880	CSR N
Duplex reverse guide kit <ul style="list-style-type: none"> • Duplex reverse guide • Installation instructions 	CC468-67913	CSR A
Back-side background selector assembly kit <ul style="list-style-type: none"> • Back-side background selector assembly • Installation instructions 	5851-5022	CSR A
Fax kit <ul style="list-style-type: none"> • Fax PCA • Fax cradle • Installation instructions 	CC478-67901	CSR A
Foam reflector kit <ul style="list-style-type: none"> • Foam reflector • Installation instructions 	5851-4878	CSR B
Formatter assembly kit (New) <ul style="list-style-type: none"> • Formatter PCA • Formatter tray • Screw (1) • Installation instructions 	CD644-67909	CSR A
Formatter assembly kit (China only) <ul style="list-style-type: none"> • Formatter PCA • Formatter tray • Screw (2) • Installation instructions 	CD644-67910	CSR A

Product name	Part number	CSR level
Front-door assembly and name plate <ul style="list-style-type: none"> • Front-door assembly • HP Jewel • Name plate • Installation instructions 	CD644-67902 NOTE: 575dn and 575f models only.	CSR A
Front-door assembly and name plate <ul style="list-style-type: none"> • Front-door assembly • HP Jewel • Name plate • Installation instructions 	CD646-67904 NOTE: 575c models only.	CSR A
Image scanner whole unit kit <ul style="list-style-type: none"> • Image scanner assembly • Foam reflector kit • Installation instructions 	CD644-67922 NOTE: 575dn and 575f models only.	CSR N
Image scanner whole unit kit <ul style="list-style-type: none"> • Image scanner assembly • Foam reflector kit • Installation instructions 	CD646-67901 NOTE: 575c models only.	CSR N
ITB service maintenance kit <ul style="list-style-type: none"> • Intermediate transfer belt (ITB) • Secondary transfer roller assembly • Installation instructions 	CD644-67908	CSR A
Laser scanner assembly kit <ul style="list-style-type: none"> • Laser/scanner assembly • Installation instructions 	CD644-67905	CSR N
Main drive assembly kit <ul style="list-style-type: none"> • Main drive assembly • Installation instructions 	CD644-67911	CSR N

Product name	Part number	CSR level
Document feeder mylar A4 kit <ul style="list-style-type: none"> Document feeder mylar <p>NOTE: The document feeder mylar kit contains six mylar guides. Only two guides are required for the product. Additional guides are to be used if the adhesive on a guide is contaminated during installation.</p> <ul style="list-style-type: none"> Installation instructions 	5851-4998	CSR N
Memory board kit <ul style="list-style-type: none"> AY memory board Installation instructions 	CD644-67924	CSR N
Photon control panel <ul style="list-style-type: none"> Photon-R control panel Installation instructions 	CD644-67916	CSR A
Photon control panel <ul style="list-style-type: none"> Photon-R control panel Control-panel FFC Installation instructions 	CD644-67920	CSR B
Pick/feed and separation roller kit (Tray 1) <ul style="list-style-type: none"> Separation pad Pickup roller Installation instructions 	CD644-67903	CSR B
Pick/feed and separation roller kit (Tray 2/3) <ul style="list-style-type: none"> Separation roller assembly Pickup roller assembly Pickup roller Feed roller Installation instructions 	CD644-67904	CSR A
Product cabinet kit <ul style="list-style-type: none"> Product cabinet Installation instructions 	CD644-67917	CSR A
Secondary transfer (T2) roller kit <ul style="list-style-type: none"> Secondary transfer roller Installation instructions 	CD644-67914	CSR A

Product name	Part number	CSR level
Spring separation pad kit	5851-4879	CSR B
<ul style="list-style-type: none"> • Spring separation pad • Installation instructions 		
Staple cartridge kit	Q7432-67901/Q7432A	CSR A
Toner collection unit (TCU) kit	CF081-67903/CE254A	CSR A
<ul style="list-style-type: none"> • Toner collection unit • Installation instructions 		
Keyboard overlay kit	NOTE: 575c models only.	CSR A
<ul style="list-style-type: none"> • Keyboard overlay • Installation instructions 	5851-5001; Russian 5851-5002; Italian 5851-5003; French 5851-5004; Portuguese 5851-5005; Spanish-Spain 5851-5006; Spanish-LA 5851-5007; French Canadian 5851-5145; German 5851-5146; French Swiss 5851-5157; German Swiss 5851-5148; Danish 5851-5148; Danish 5851-5149; Traditional Chinese 5851-5150; Simlified Chinese	

Related documentation and software

Table 2-2 Related documentation and software

Item	Description	Part number
<i>HP LaserJet Enterprise 500 color MFP M575 and HP LaserJet Enterprise color flow MFP M575 Printer User Guide</i>	Product user guide	CD644-90907
<i>HP LaserJet Enterprise 500 color MFP M575 and HP LaserJet Enterprise color flow MFP M575 Printer Service Repair Manual</i>	English service repair manual	CD644-90966
<i>HP LaserJet Enterprise 500 color MFP M575 and HP LaserJet Enterprise color flow MFP M575 Printer Service Troubleshooting Manual</i>	English service troubleshooting manual	CD644-90967

Fasteners used in this product





 **NOTE:** The screw illustrations in the following table are for reference only. Screws might vary in size and appearance from those shown in this table.

Table 2-3 Common fasteners

Example	Description	Size	Part Number
	Screw, tapping, truss head	M4X10	XB4-7401-005CN
	Screw, tapping, pan head	M4X10	XB4-7401-007CN
	Screw, D	M3X8	XA9-1671-000CN
	Screw, D	M3X8	XA9-1834-000CN
	Screw (formatter assembly)	M3X0.5	0515-4679

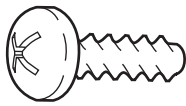
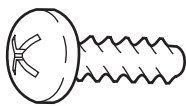
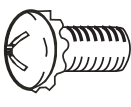
6 mm 8 mm 10 mm M 3 M 4

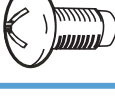
How to use the parts lists and diagrams

The figures in this chapter show the major subassemblies in the product and their component parts. A parts list table follows each exploded view assembly diagram. Each table lists the item number, the associated part number, and the description of each part. If a part is not listed in the table, then it is not a field replacement unit (FRU).

 **CAUTION:** Be sure to order the correct part. When looking for part numbers for electrical components, pay careful attention to the voltage that is listed in the description column. Doing so will ensure that the part number selected is for the correct all-in-one model.

 **NOTE:** In this manual, the abbreviation “PCA” stands for “printed circuit-board assembly.” Components described as a PCA might consist of a single circuit board or a circuit board plus other parts, such as cables and sensors.

Assembly locations

Base product (no optional trays or accessories)

Figure 2-1 Base product (no optional trays or accessories)

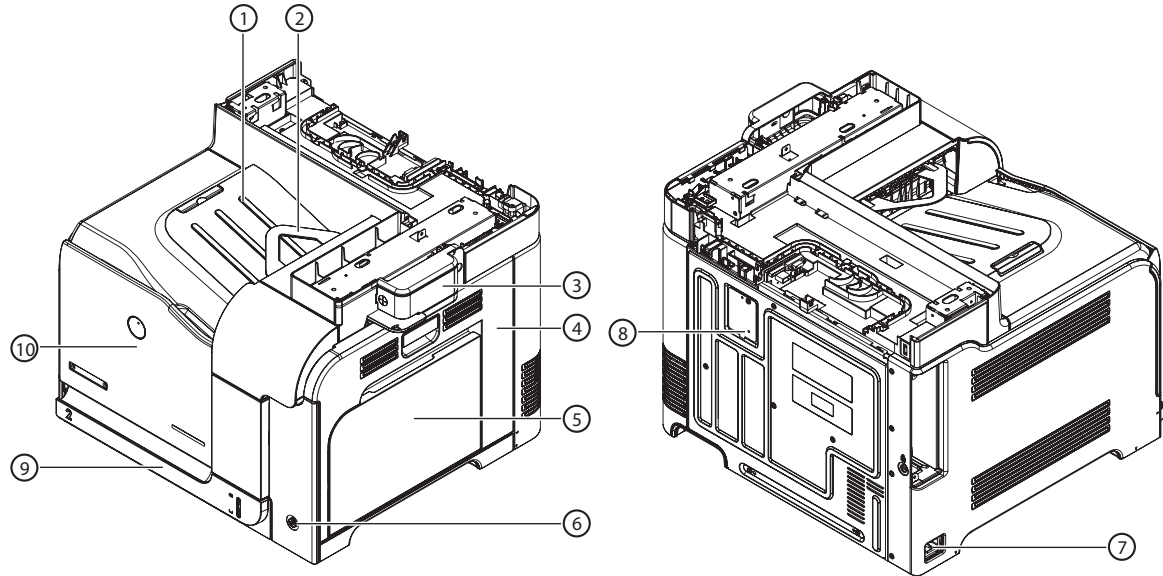

Item	Description	Item	Description
1	Face-down output bin	6	Power switch
2	Reverse tray	7	Power receptacle
3	Stapler cover	8	Test print switch
4	Right door	9	Tray 2
5	Tray 1	10	Front door

Base product (optional trays or accessories)

Figure 2-2 Base product (optional trays or accessories)

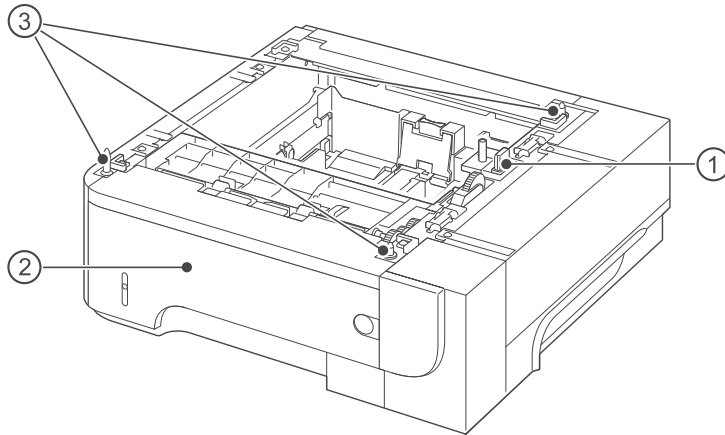

Table 2-4 Optional 500-sheet input tray

Item	Description
1	Connector
2	Tray 3
3	Positioning pins

Covers

Figure 2-3 External covers, panels, and doors

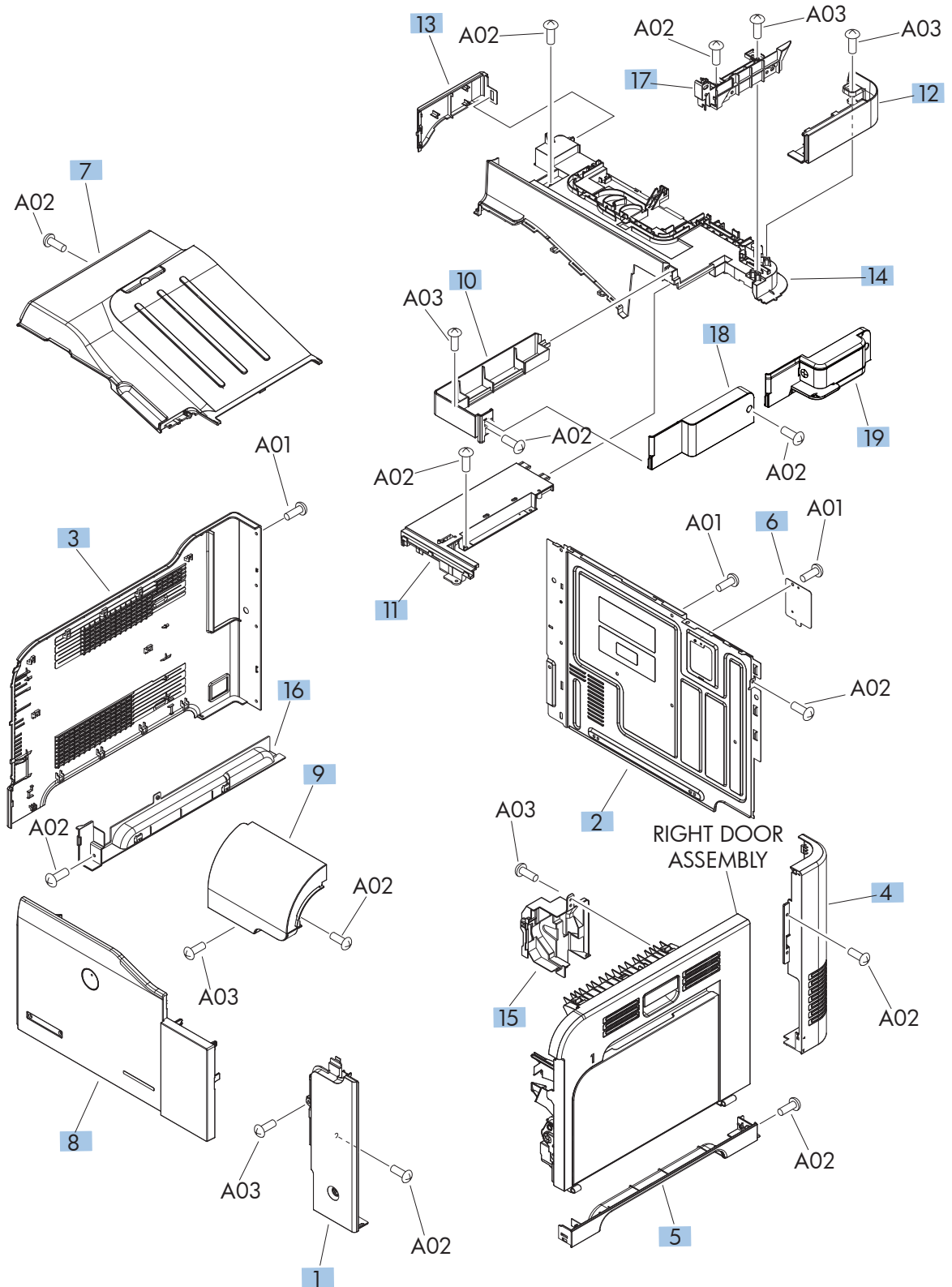

Table 2-5 External covers, panels, and doors

Ref	Description	Part number	Qty
1	Cover, right front	RC2-5056-000CN	1
2	Cover, rear	RC2-5048-000CN	1
3	Cover, left	RC2-5052-000CN	1
4	Cover, rear right	RC2-5057-000CN	1
5	Cover, right lower	RC2-5059-000CN	1
6	Plate, blanking	RC2-5938-000CN	1
7	Tray, paper delivery	RL1-1941-030CN	1
8	Front door assembly; 575dn and 575f models	CD644-67902	1
8	Front door assembly; 575c model	CD646-67904	1
9	Control panel cover assembly	RM1-9198-000CN	1
10	Cover, right	RC3-2095-000CN	1
11	Cover, upper right	RC3-2093-000CN	1
12	Cover, right rear	RC3-2096-000CN	1
13	Cover, left rear	RC3-2094-000CN	1
14	Cover, upper rear	RC3-2092-000CN	1
15	Cover, right door gear rear	RC2-4924-000CN	1
16	Cover, left lower	RC2-5069-000CN	1
17	Guide, cable	RC3-2103-000CN	1
18	Cover, image scanner unit	RRC3-2097-000CN	1
19	Cover, stapler unit	RM1-9199-000CN	1

Document feeder and scanner assemblies (M575dn and 575f models)

Figure 2-4 Document feeder and scanner assemblies (M575dn and 575f models)

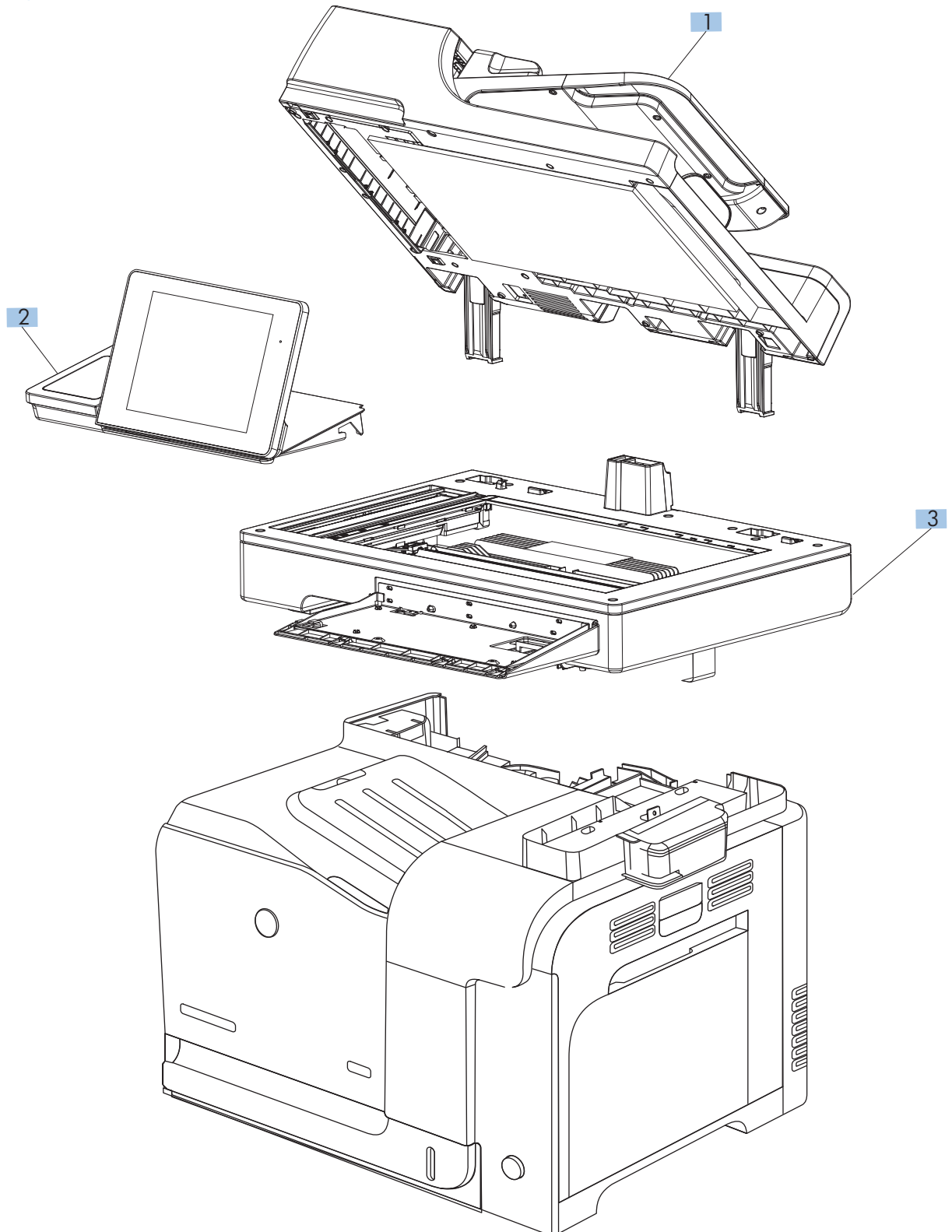

Table 2-6 Document feeder and scanner assemblies (M575dn and 575f models)

Ref	Description	Part number	Qty
1	ADF whole unit	CD644-67918	1
2	Control panel	CD644-67916	1
3	Scanner whole unit	CD644-67922	1
Not Shown	PCA, scanner control board	CD644-67926	1

Document feeder and scanner assemblies (M575c model)

Figure 2-5 Document feeder and scanner assemblies (575c models)

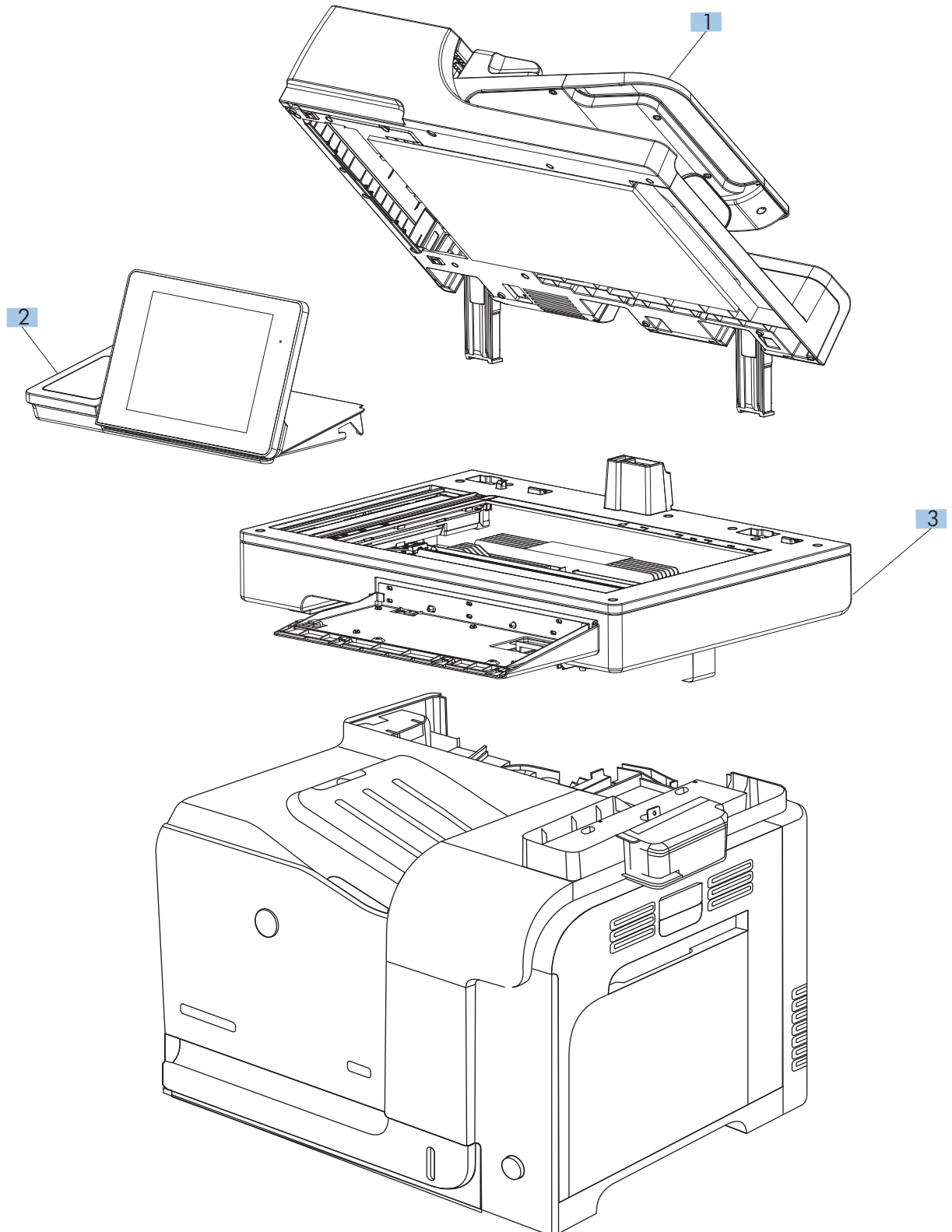

Table 2-7 Document feeder and scanner assemblies (575c models)

Ref	Description	Part number	Qty
1	Document feeder whole unit, M575c	CD644-67921	1
2	Control panel, M575c	CD644-67920	1
Not shown	FFC, control-panel keyboard, M575c	CD644-60113	1
3	Scanner whole unit, M575c	CD646-67901	1
Not Shown	PCA, scanner control board, M575c	CD646-67902	1
Not Shown	e-Duplex assembly, document feeder, M575c	5851-5022	1

Keyboard (M575c model)

Figure 2-6 Keyboard and brackets

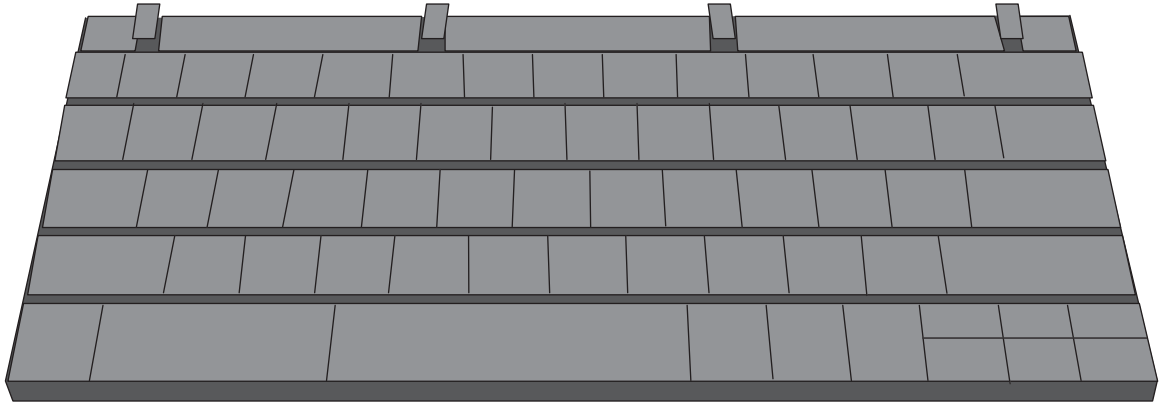

Table 2-8 Keyboard and brackets

Ref	Description	Part number	Qty
1	Keyboard assembly English, M575c	5851-5380	1
1	Keyboard assembly United Kingdom, M575c	5851-5008	1

Control panel assembly

Figure 2-7 Control panel assembly

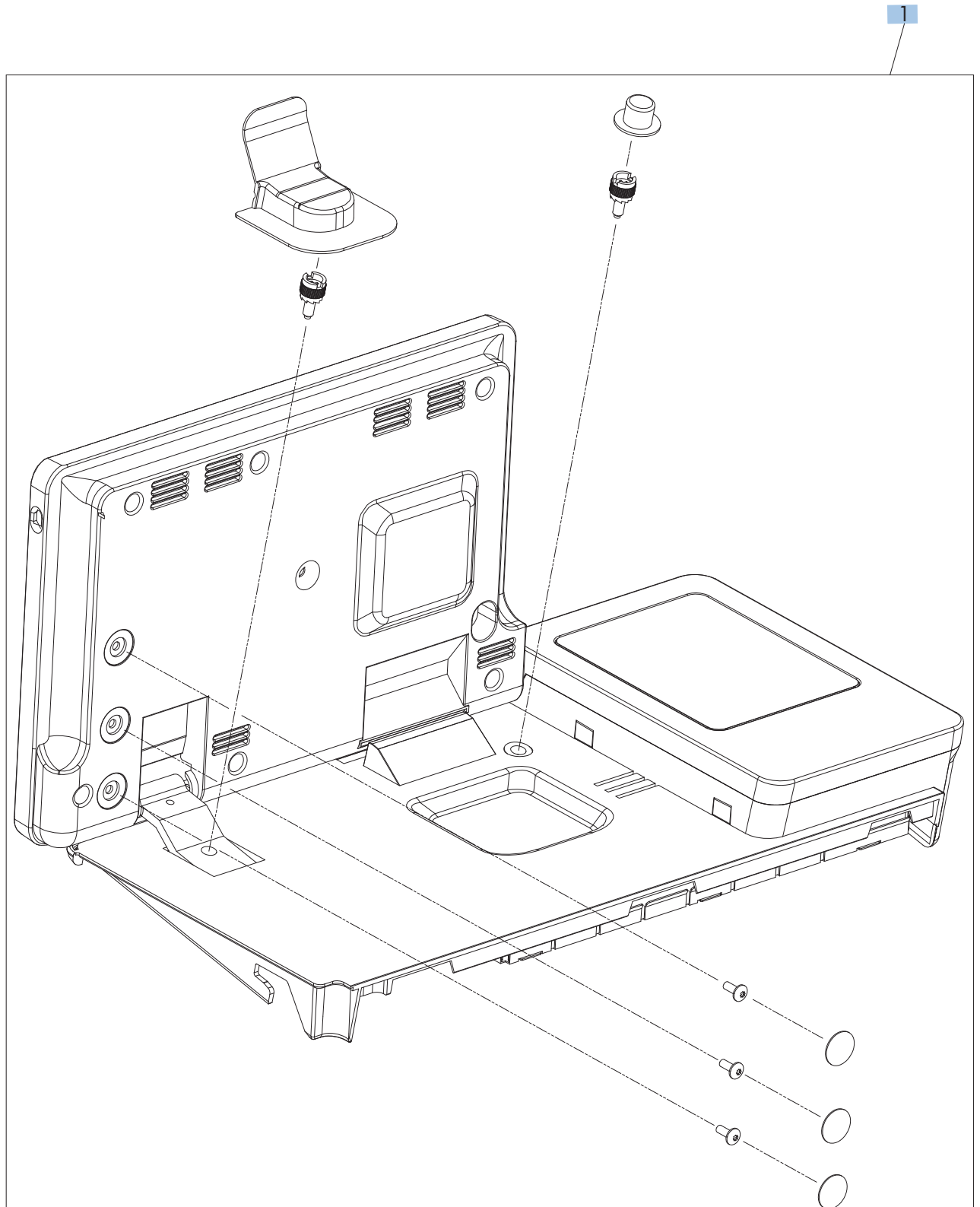

Table 2-9 Control panel assembly

Ref	Description	Part number	Qty
1	Control panel assembly kit, 575dn and 575f	CD644-67916	1
1	Control panel assembly kit, 575c	CD644-67920	1
Not shown	Control-panel FFC, 575c	CD644-60113	1

ADF assemblies

Figure 2-8 ADF assemblies

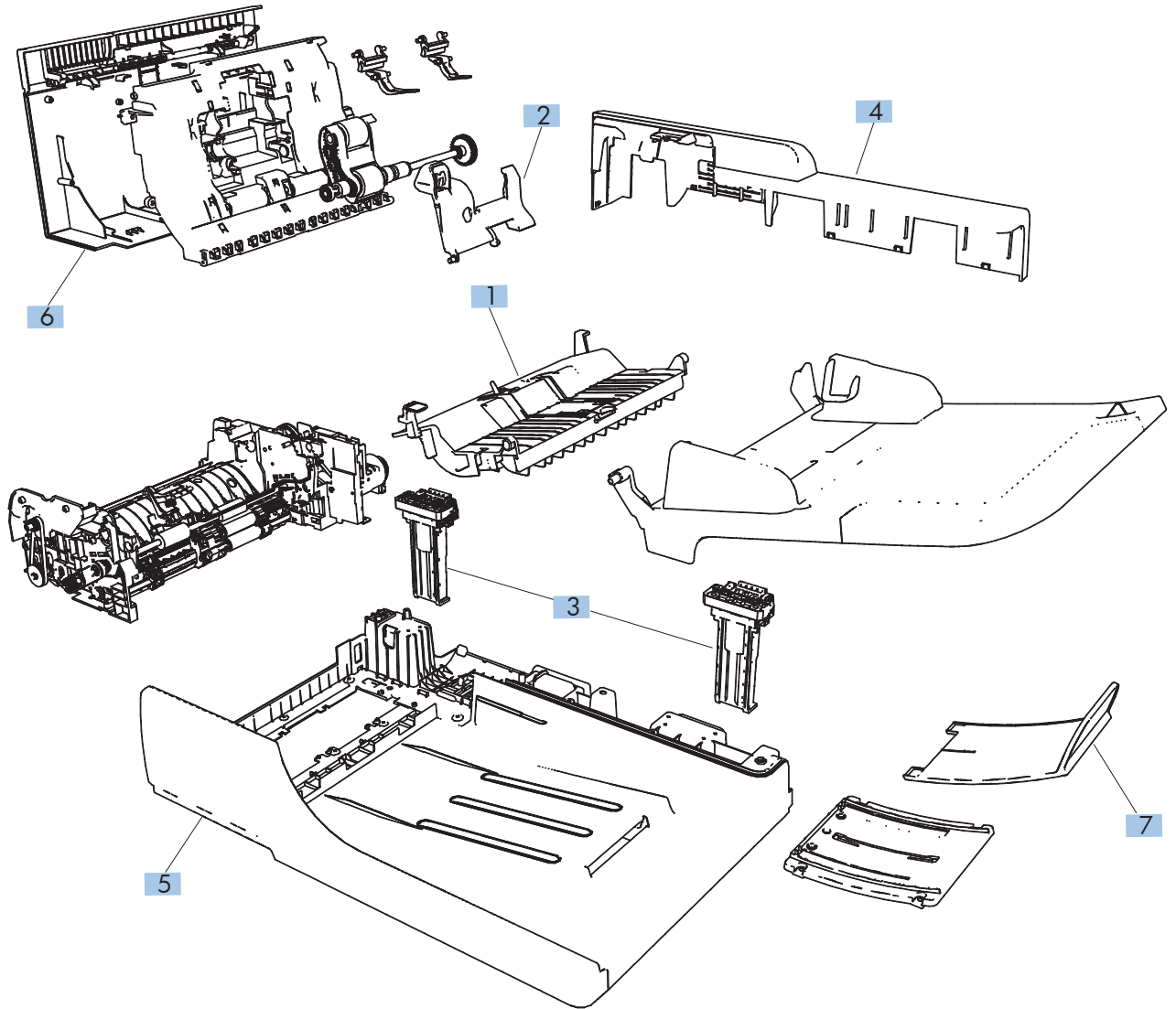

Table 2-10 ADF assemblies

Ref	Description	Part number	Qty
1	ADF separation pad spring	5851-4879	1
2	ADF roller cover	CC355-40013	1
3	ADF hinge assembly	Q7404-60024	2
4	Cover, ADF rear	Q7404-40007	1
5	Cover, ADF front	Q7404-40030	1
6	Cover, hatch	Q7404-40006	1
7	ADF tray extender	Q7404-40020	1

Scanner assemblies

Figure 2-9 Scanner assemblies

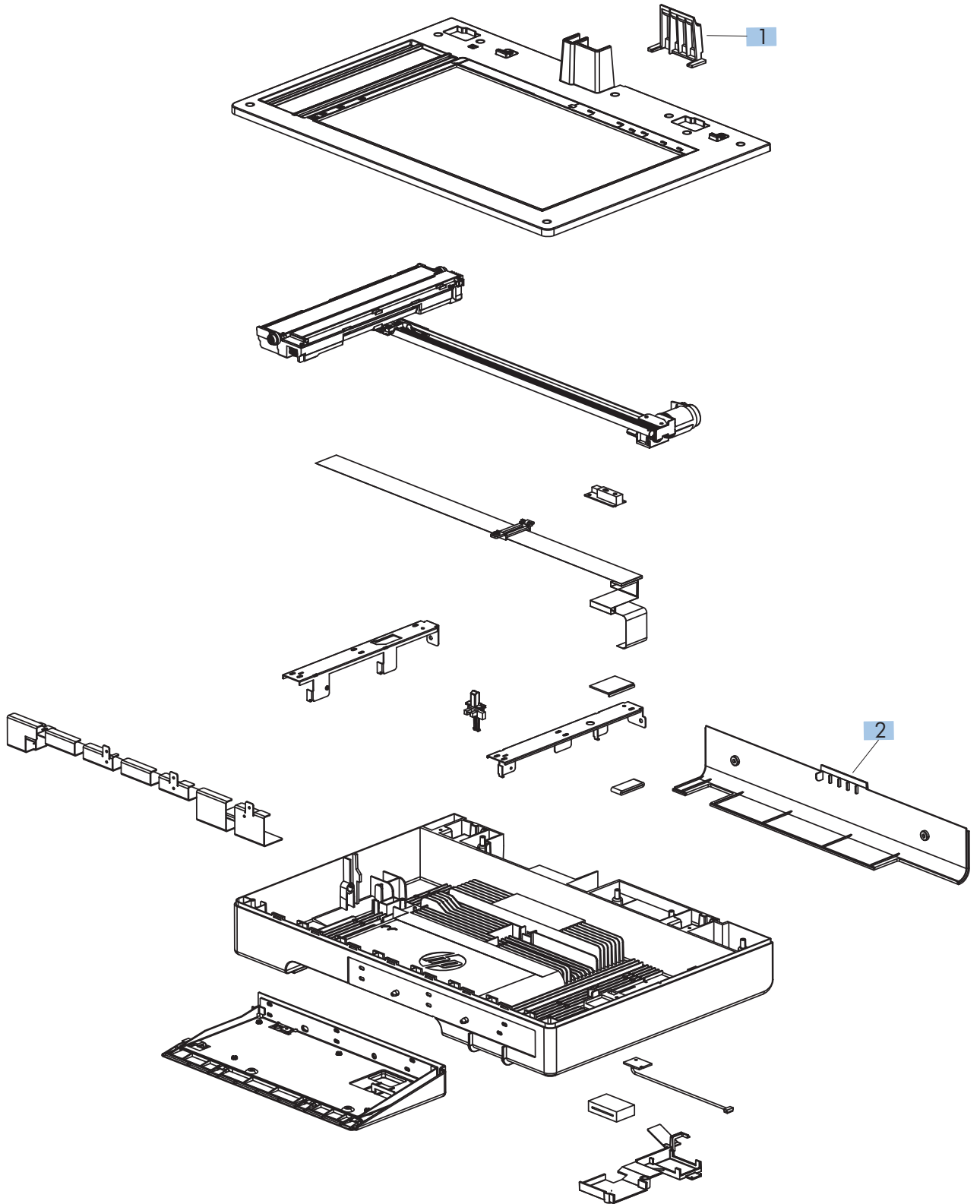

Table 2-11 Scanner assemblies

Ref	Description	Part number	Qty
1	Cover, ADF cable	5851-0630	1
2	Cover, rear scanner	CD644-40001	1
Not shown	PCA, scanner memory	CD644-67924	1
Not shown	Cave light	CF116-60104	1
Not shown	Cable harness merge assy	Q7404-50005	1

Right-door assembly

Figure 2-10 Right-door assembly

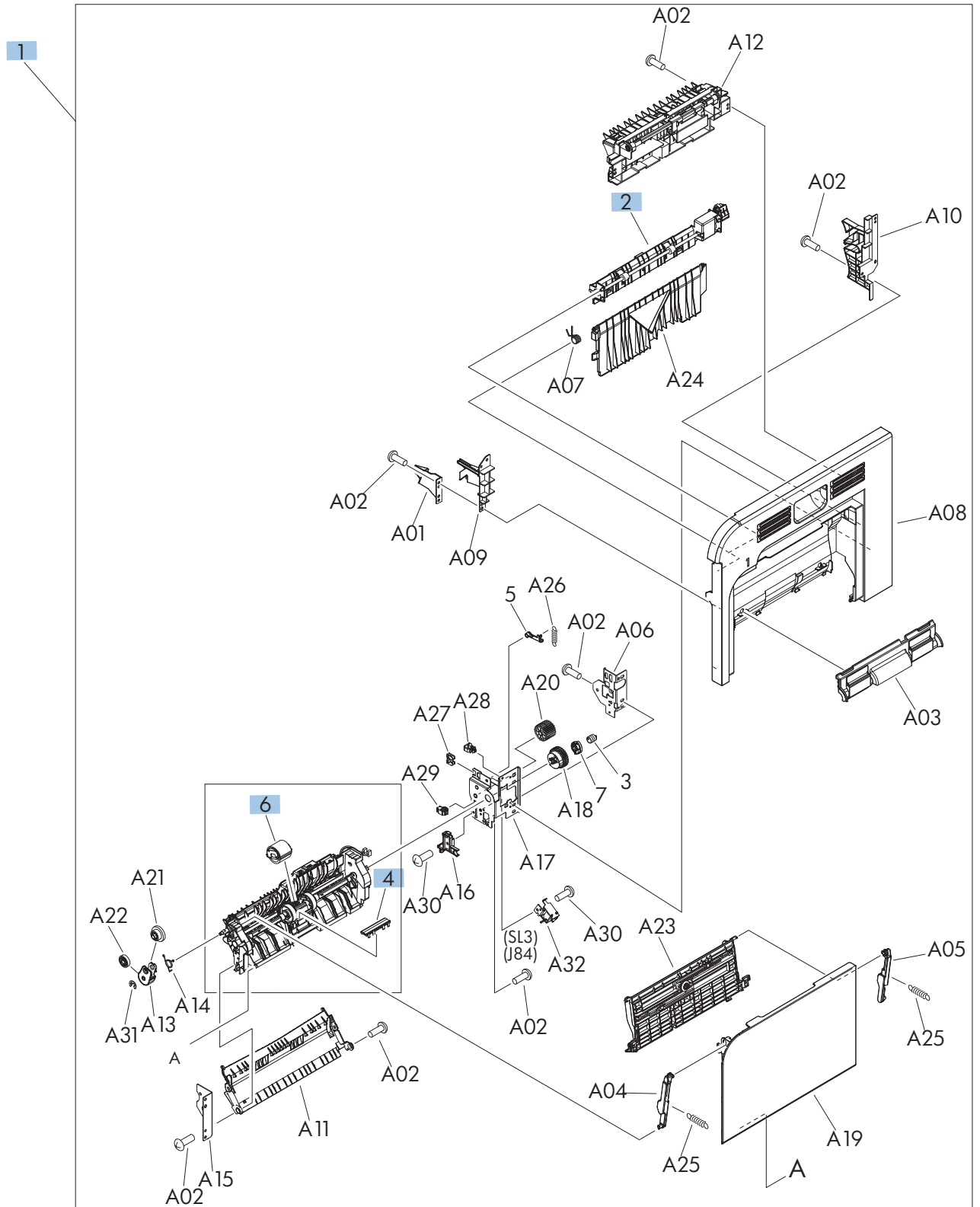

Table 2-12 Right-door assembly

Ref	Description	Part number	Qty
1	Right door assembly	RM1-8123-000CN	1
2	Duplexing paper feed assembly	RM1-4959-000CN	1
4, 6	Kit, Tray 1 roller (pickup roller and separation pad)	CD644-67903	1

Internal assemblies

Internal assemblies (1 of 6)

Figure 2-11 Internal assemblies (1 of 6)

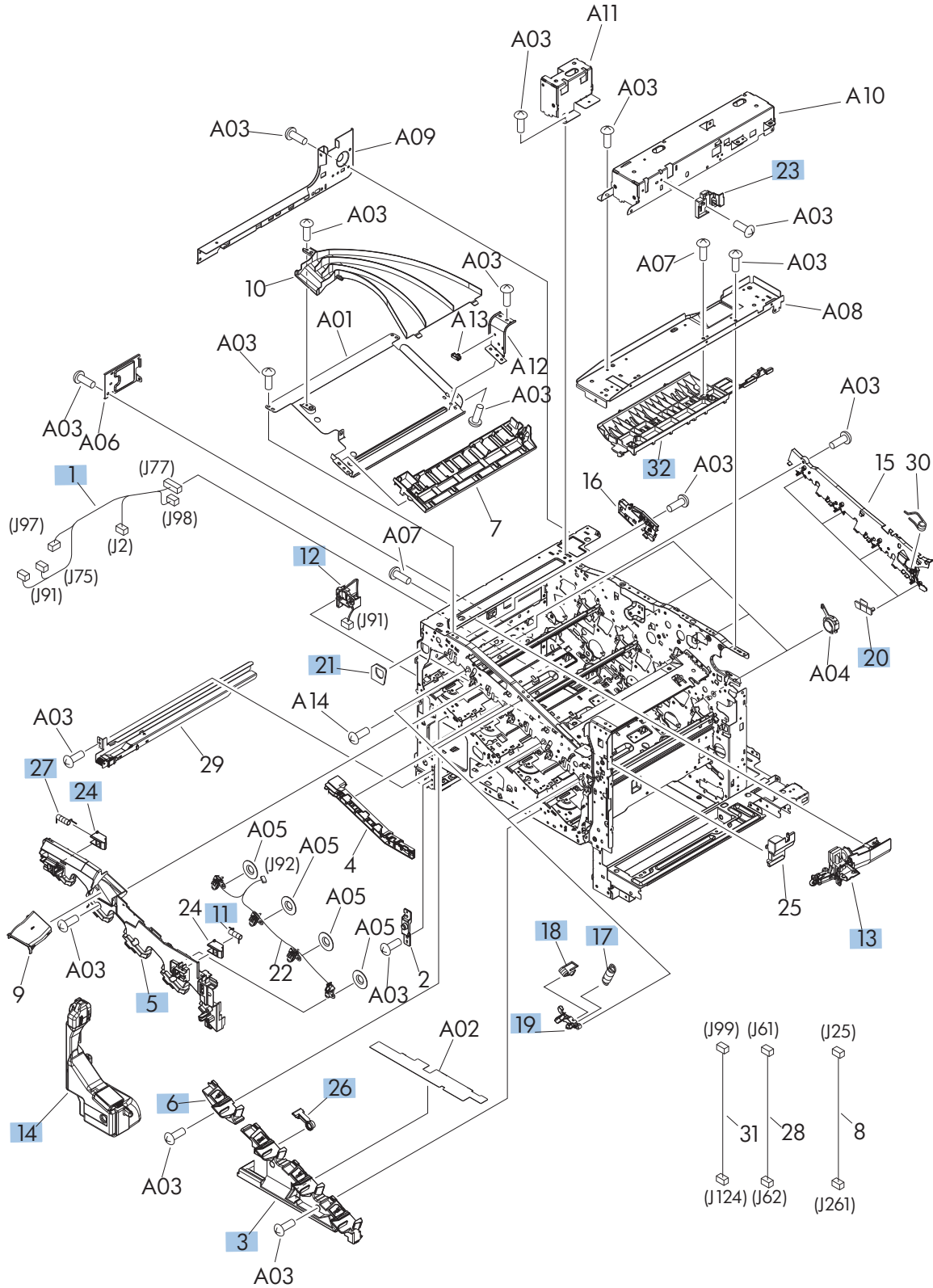

Table 2-13 Internal assemblies (1 of 6)

Ref	Description	Part number	Qty
1	Left cable assembly	RM1-5742-000CN	1
3	Cover, front inner lower unit	RL1-1914-020CN	1
5	Cover, front inner upper	RC3-1070-000CN	1
6	Cover, front inner lower	RL1-1915-000CN	1
11	Spring, compression	RU6-2567-000CN	1
12	Waste toner detect assembly	RM1-5696-000CN	1
13	Waste toner duct assembly	RM1-8138-000CN	1
14	Toner collection unit (TCU)	RM1-4989-000CN	1
17	Spring, tension	RU7-2192-000CN	4
18	Spring, ground	RU6-2237-000CN	4
19	Lever, cartridge pressure front	RC2-3983-030CN	4
20	Guide, light	RC2-4426-000CN	4
21	Waste toner box seal	RC2-4780-000CN	4
23	Cover, stapler switch	RC3-2116-000CN	4
24	Lock, door	RC2-5937-000CN	2
26	Lever, box presence detect	RC2-5951-000CN	1
27	Spring, compression	RU6-2568-000CN	1
32	Guide, door latch right	RC2-4914-000CN	1

Internal assemblies (2 of 6)

Figure 2-12 Internal assemblies (2 of 6)

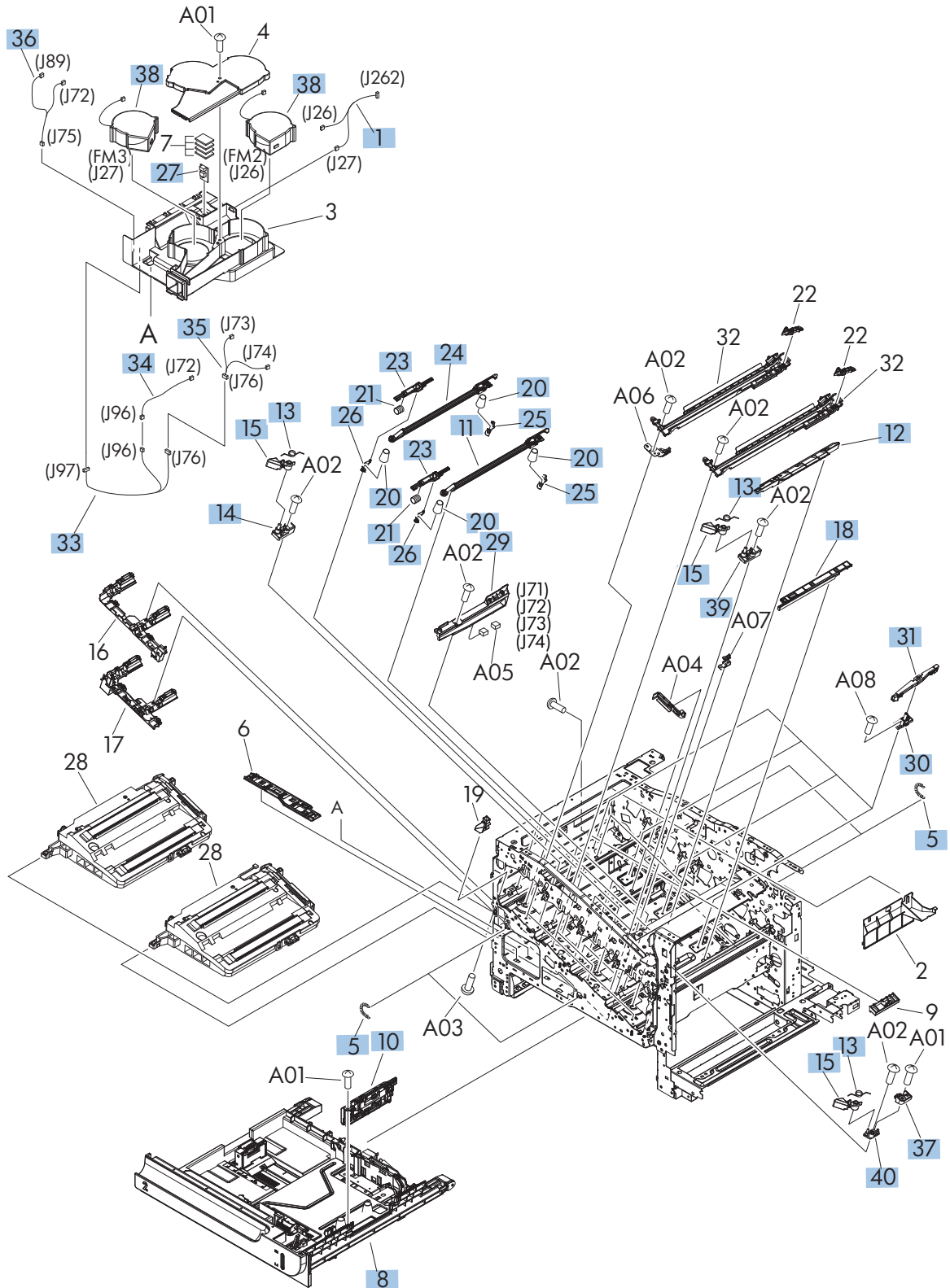

Table 2-14 Internal assemblies (2 of 6)

Ref	Description	Part number	Qty
1	Fan cable assembly	RM1-5746-000CN	1
5	Spring, tension	RU6-2436-000CN	4
8	Tray 2	RM1-4962-060CN	1
10	Separation roller assy (part of roller kit)	RM1-4966-020CN	1
11	Shutter assembly	RM1-4999-000CN	2
12	Cover	RC2-5912-000CN	1
13	Spring, torsion	RC2-5958-000CN	4
14	Holder, cartridge lock lever	RC2-5955-000CN	1
15	Lever, cartridge lock lever	RC2-5954-000CN	4
18	Cover	RC2-5962-000CN	1
20	Spring, compression	RU6-2318-000CN	8
21	Spring, compression	RU6-2316-000CN	4
23	Lever, shutter	RC2-4415-000CN	4
24	Shutter assembly	RM1-5488-000CN	2
25	Arm, shutter rear	RC2-4407-030CN	4
26	Arm, shutter front	RC2-4406-000CN	4
27	Temperature sensor unit	RK2-3267-000CN	1
29	Toner sensor holder assembly	RM1-5700-000CN	4
30	Stand assembly	RM1-5588-000CN	4
31	Base assembly	RM1-8149-000CN	4
33	Connecting cable assembly	RM1-5749-000CN	1
34	Sensor cable assembly	RM1-5740-000CN	1
35	Sensor cable assembly	RM1-5741-000CN	1
36	Motor/sensor cable assembly	RM1-5752-000CN	1
37	Cartridge lock lever holder	RC2-5957-000CN	1
38	Fan (FM2, FM3)	RK2-2418-000CN	2
39	Cartridge lock lever holder	RC3-1075-000CN	2
40	Cartridge lock lever holder	RC2-5956-000CN	2

Internal assemblies (3 of 6)

Figure 2-13 Internal assemblies (3 of 6)

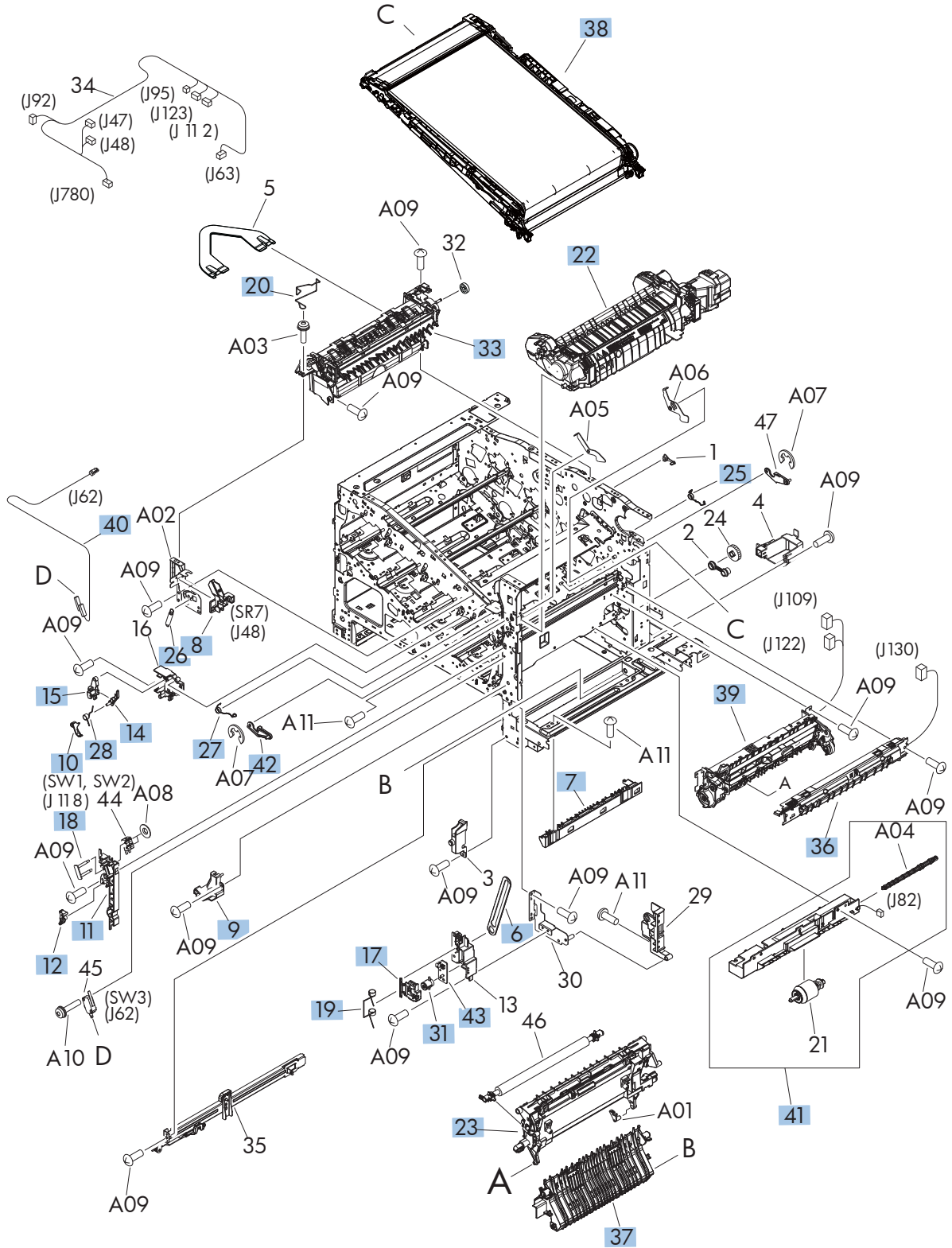

Table 2-15 Internal assemblies (3 of 6)

Ref	Description	Part number	Qty
6	Link, door stopper	RC2-4916-000CN	1
7	Guide, option entrance	RC2-4915-000CN	1
8	Sensor cable guide assembly (SR7)	RM1-8178-000CN	1
9	Cover, inner right lower	RC2-5019-000CN	1
10	Link, interlock (SW1)	RC2-5120-000CN	1
11	Mount, interlock switch	RC2-5123-000CN	1
12	Arm, interlock link switch	RC2-5121-000CN	1
14	Link, interlock	RC2-5119-000CN	1
15	Link, interlock	RC2-5118-000CN	1
17	Lever, switch	RC3-1208-000CN	1
18	Shaft	RC2-5913-000CN	1
19	Spring	RC3-1212-000CN	1
20	Wire (mech) sensor project	RC2-4828-000CN	1
22	Fuser 110v	CD644-67906	1
22	Fuser 220v	CD644-67907	1
23	Secondary transfer assembly	RM1-4952-030CN	1
25	Spring, torsion	RC2-4378-000CN	1
26	Spring, torsion	RU6-2268-000CN	1
27	Spring, torsion	RC2-4377-000CN	1
28	Spring, torsion	RC2-5122-000CN	1
31	Button, power supply	RL1-1947-000CN	1
33	Paper delivery assembly	RM1-4970-060CN	1
36	Density detect assembly	RM1-8163-000CN	1
37	Pick up lower guide assembly	RM1-9192-000CN	1
38	ITB kit	CD644-67908	1
39	Registration assembly	RM1-4969-000CN	1
40	Switch cable assembly	RM1-8065-000CN	1
41	Paper pick up assembly	RM1-4967-000CN	1
42	Front lock arm assembly	RM1-5532-000CN	1
43	Switch PCA assembly	RM1-8097-000CN	1

Internal assemblies (4 of 6)

Figure 2-14 Internal assemblies (4 of 6)

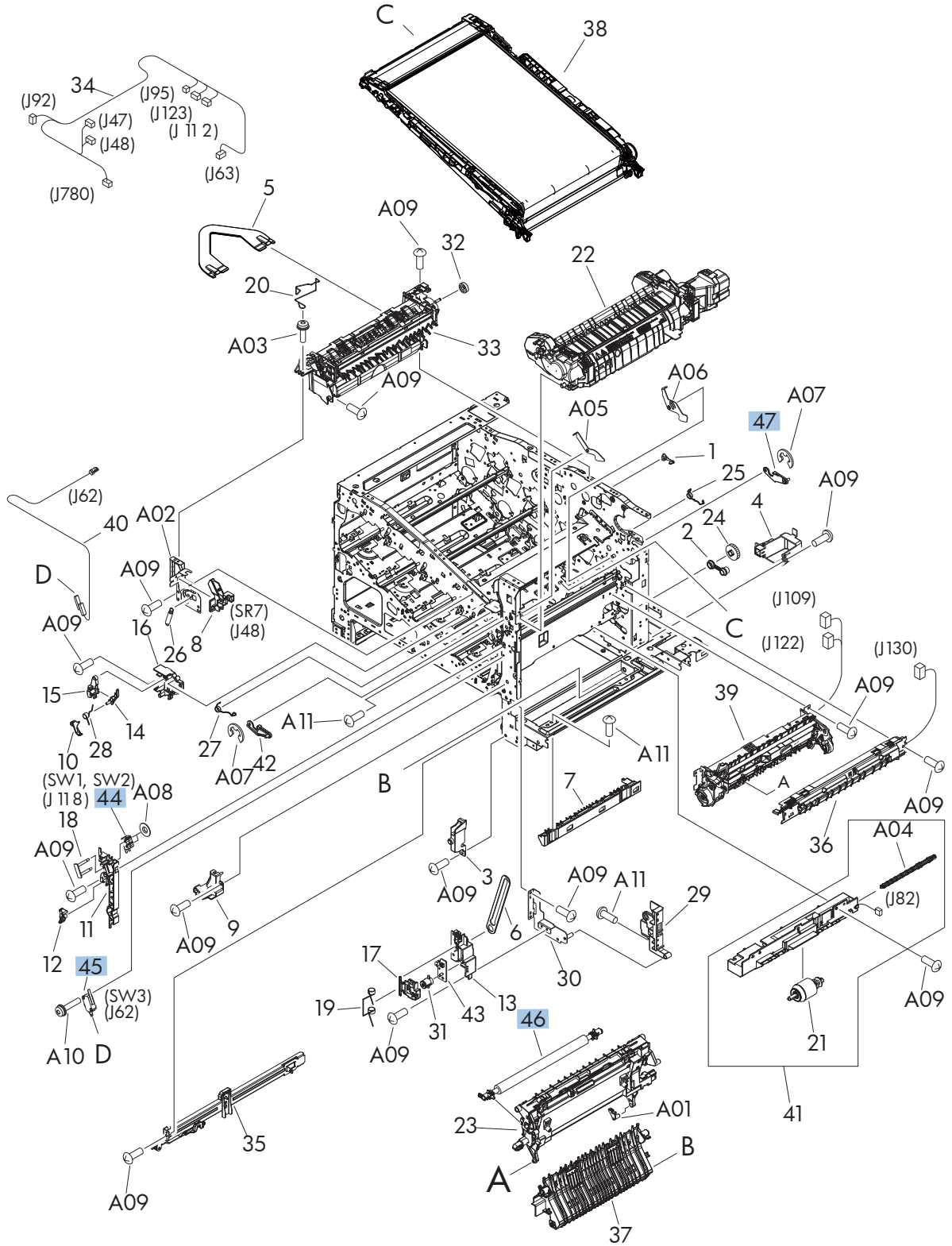

Table 2-16 Internal assemblies (4 of 6)

Ref	Description	Part number	Qty
44	Door switch assembly (SW2)	RM1-5732-000CN	1
45	Microswitch (SW3)	WC4-5171-000CN	1
46	Secondary transfer roller	CD644-67914	1
47	Rear lock arm assembly	RM1-5533-000CN	1

Internal assemblies (5 of 6)

Figure 2-15 Internal assemblies (5 of 6)

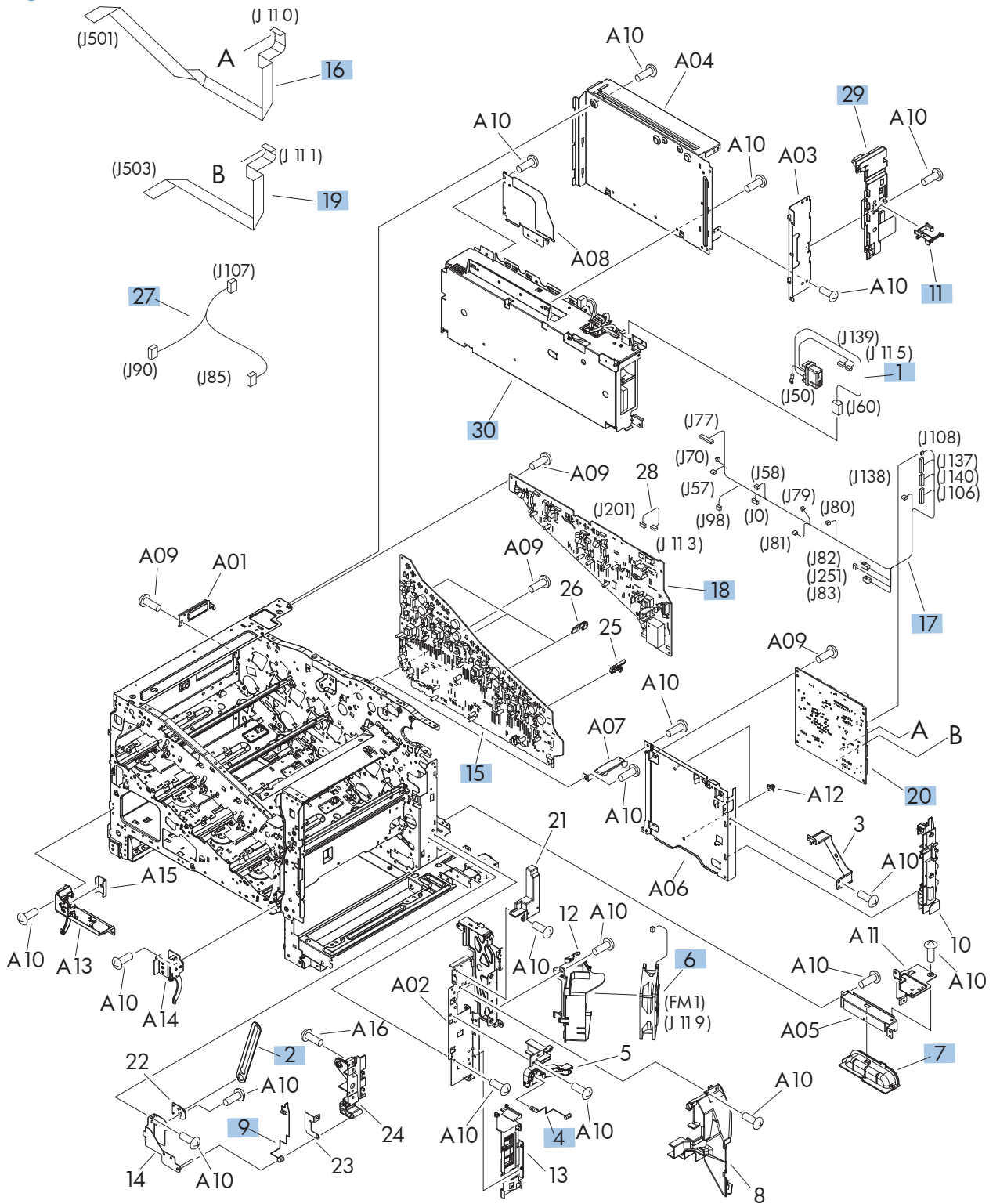

Table 2-17 Internal assemblies (5 of 6)

Ref	Description	Part number	Qty
1	Fusing connecting cable assembly	RM1-5714-000CN	1
2	Link, door stopper	RC2-4916-000CN	1
4	Spring, compression	RC2-5021-000CN	1
6	Fan (FM1)	RK2-2416-000CN	1
7	Rear handle	RC2-5042-000CN	1
9	Spring, grounding	RC2-5148-000CN	1
11	Switch arm	RC2-5943-000CN	1
15	Lower HVPS (D)	RM1-8087-000CN	1
16	Cable, laser FCC 1	RK2-3941-000CN	1
17	Cable, rear assembly	RM1-8084-000CN	1
18	Upper HVPS (T)	RM1-8088-000CN	1
19	Cable, laser FCC 2	RK2-3943-000CN	1
20	DC Controller	RM1-8119-000CN	1
27	Cable, MP sensor assembly	RM1-5737-000CN	1
29	Interconnect PCA (ICB)	RM1-8086-000CN	1
30	LVPS (110V)	RM1-8102-000CN	1
30	LVPS (220V)	RM1-8103-000CN	1

Internal assemblies (6 of 6)

Figure 2-16 Internal assemblies (6 of 6)

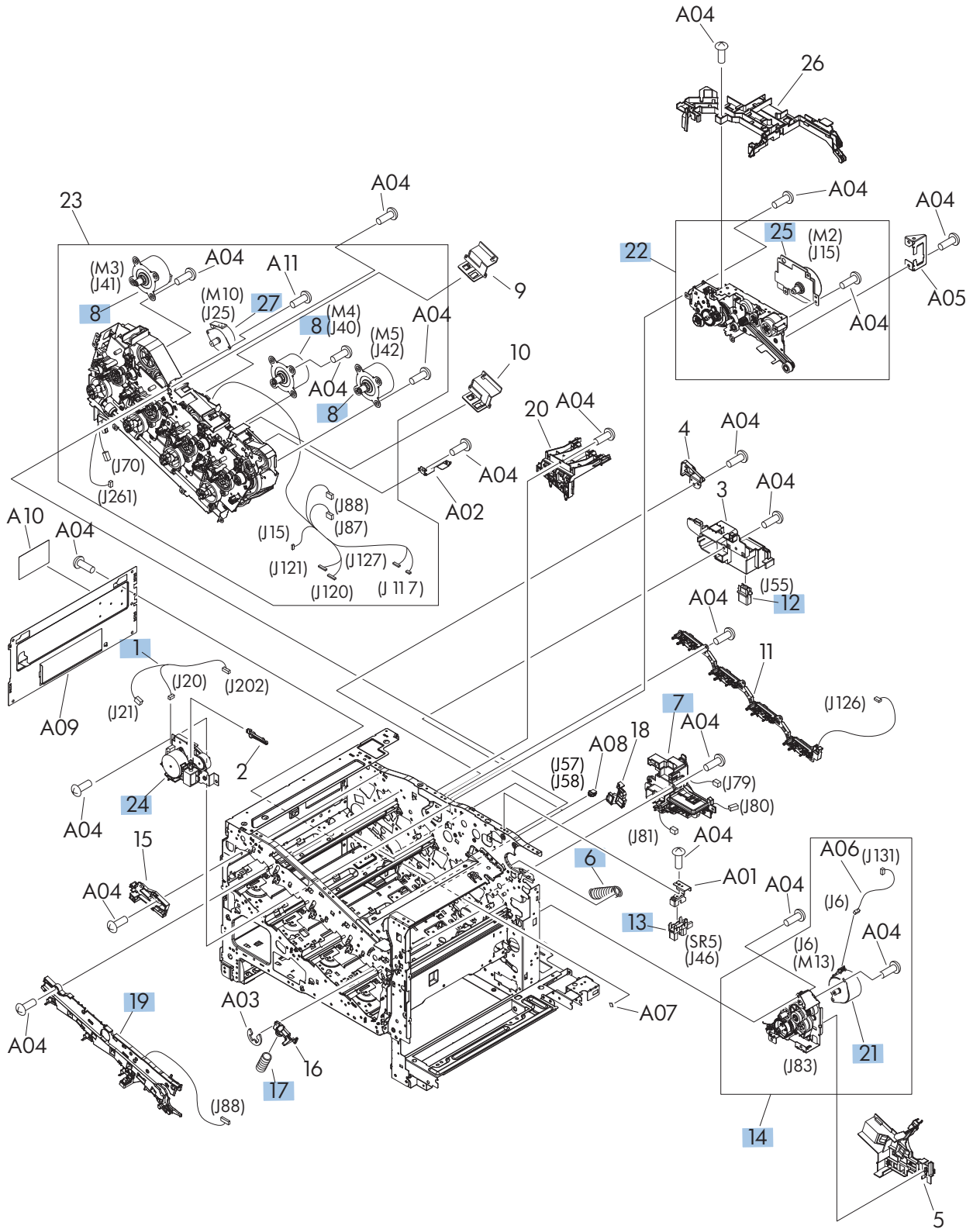

Table 2-18 Internal assemblies (6 of 6)

Ref	Description	Part number	Qty
1	Duplexing unit cable assembly	RM1-5730-000CN	1
6	Spring, tension	RU6-2405-000CN	1
7	Lifter drive assembly	RM1-4976-000CN	1
8	Main motor unit (M3, M4, M5)	RM1-8105-000CN	3
12	Connector, drawer	VS1-7258-007CN	1
13	Photo interrupter (SR5)	WG8-5935-000CN	1
14	Paper pick up drive assembly	RM1-8135-000CN	1
17	Spring, compression	RU7-2193-000CN	1
19	Rear Pre-exposure PCA assembly	RM1-8174-000CN	1
21	Pickup motor assembly (M13)	RM1-5773-000CN	1
22	Fusing drive assembly	RM1-8134-000CN	1
24	Duplex drive assembly	RM1-4973-000CN	1
25	Fusing motor assembly (M2)	RM1-4983-000CN	1
27	Stepping motor, DC (M10)	RK2-2415-000CN	1

Tray 2

Figure 2-17 Tray 2

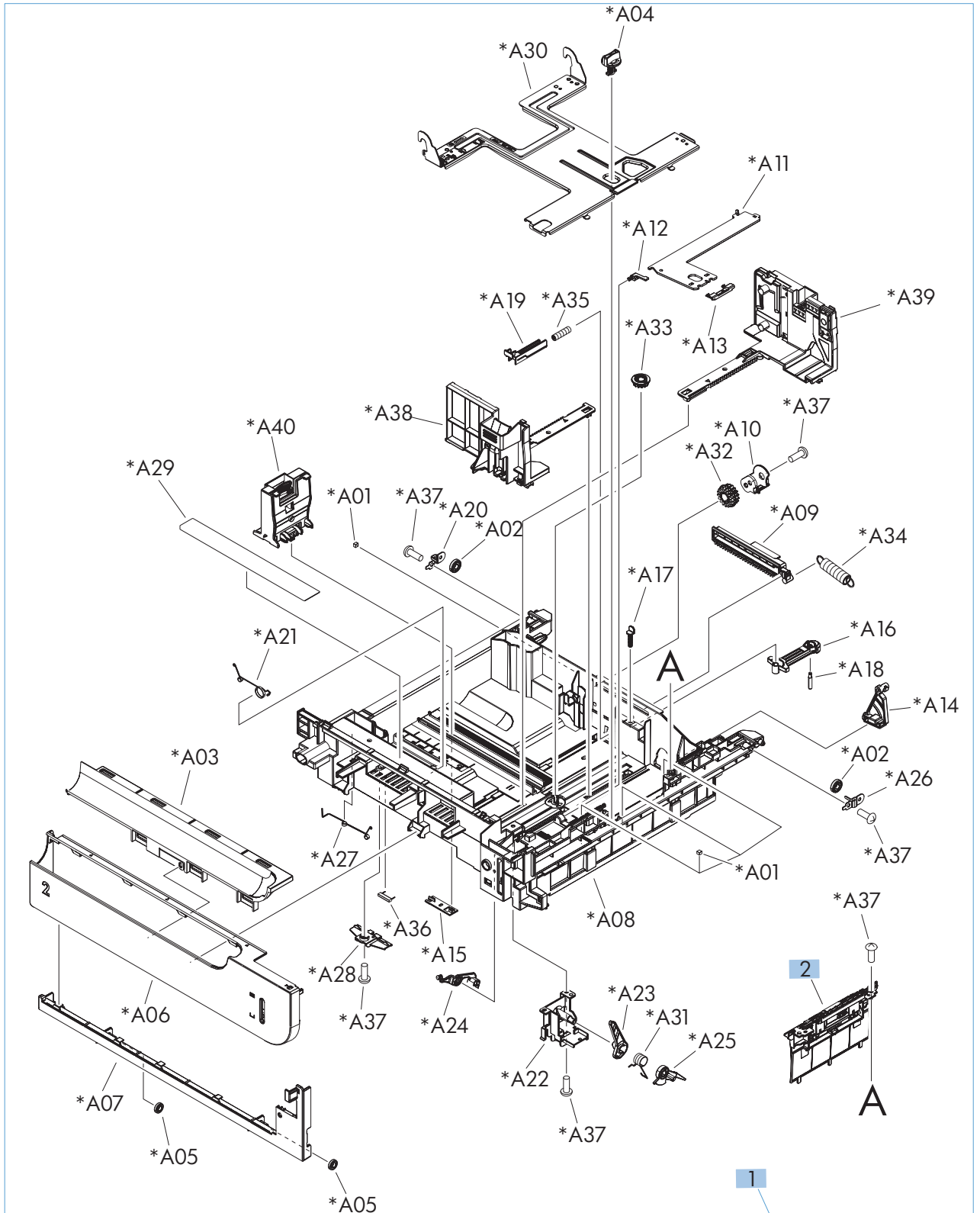

Table 2-19 Tray 2

Ref	Description	Part number	Qty
1	Tray 2	RM1-6198-000CN	1
2	Separation roller assembly (part of roller kit)	CD644-67904	1

Paper pickup assembly

Figure 2-18 Paper pickup assembly (Tray 2)

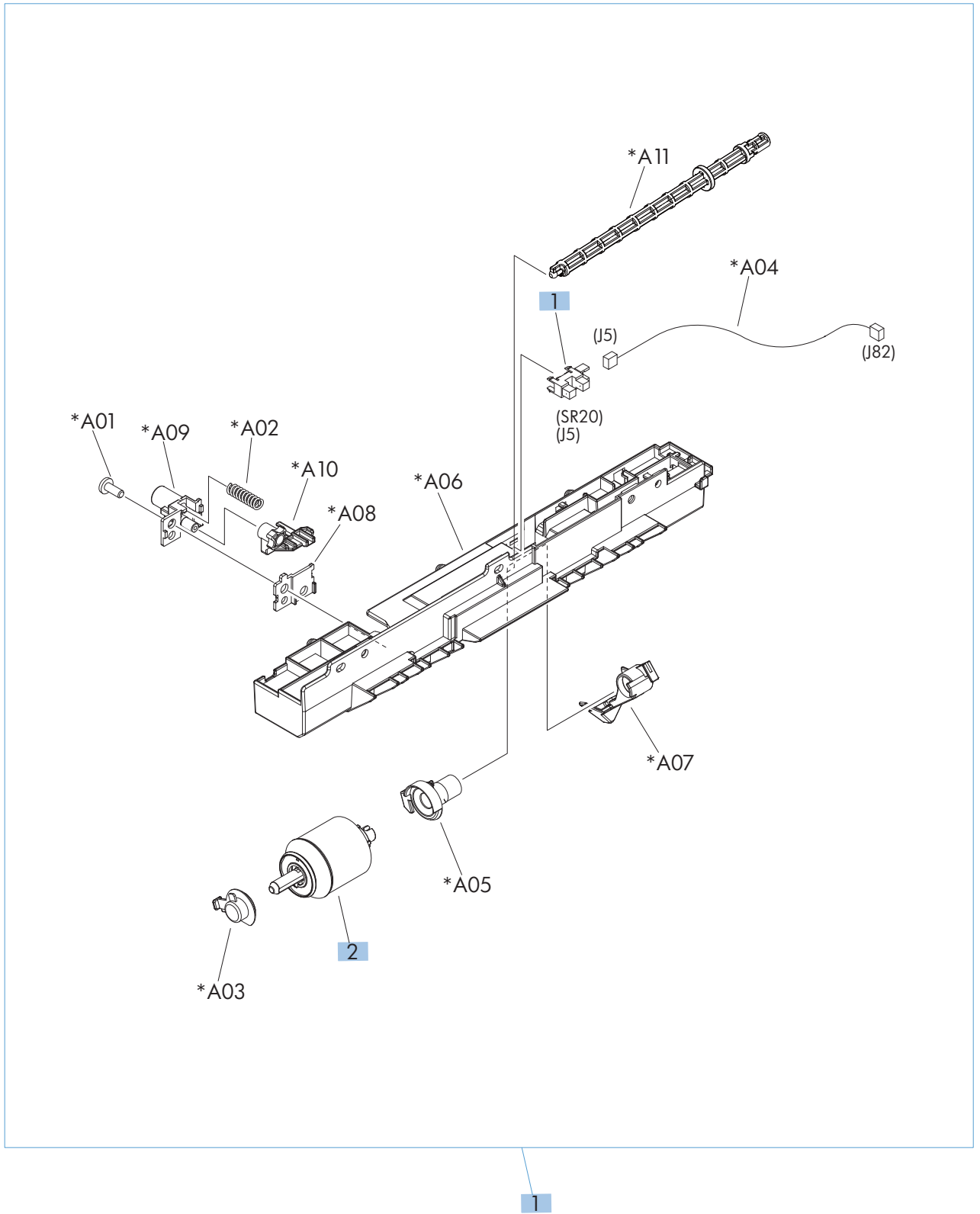

Table 2-20 Paper pickup assembly (Tray 2)

Ref	Description	Part number	Qty
1	Paper pickup assembly	RM1-4967-000CN	1
2	Pickup roller	RM1-4968-040CN	1
3	Photointerrupter	WG8-5935-000CN	1

PCAs

Figure 2-19 PCAs

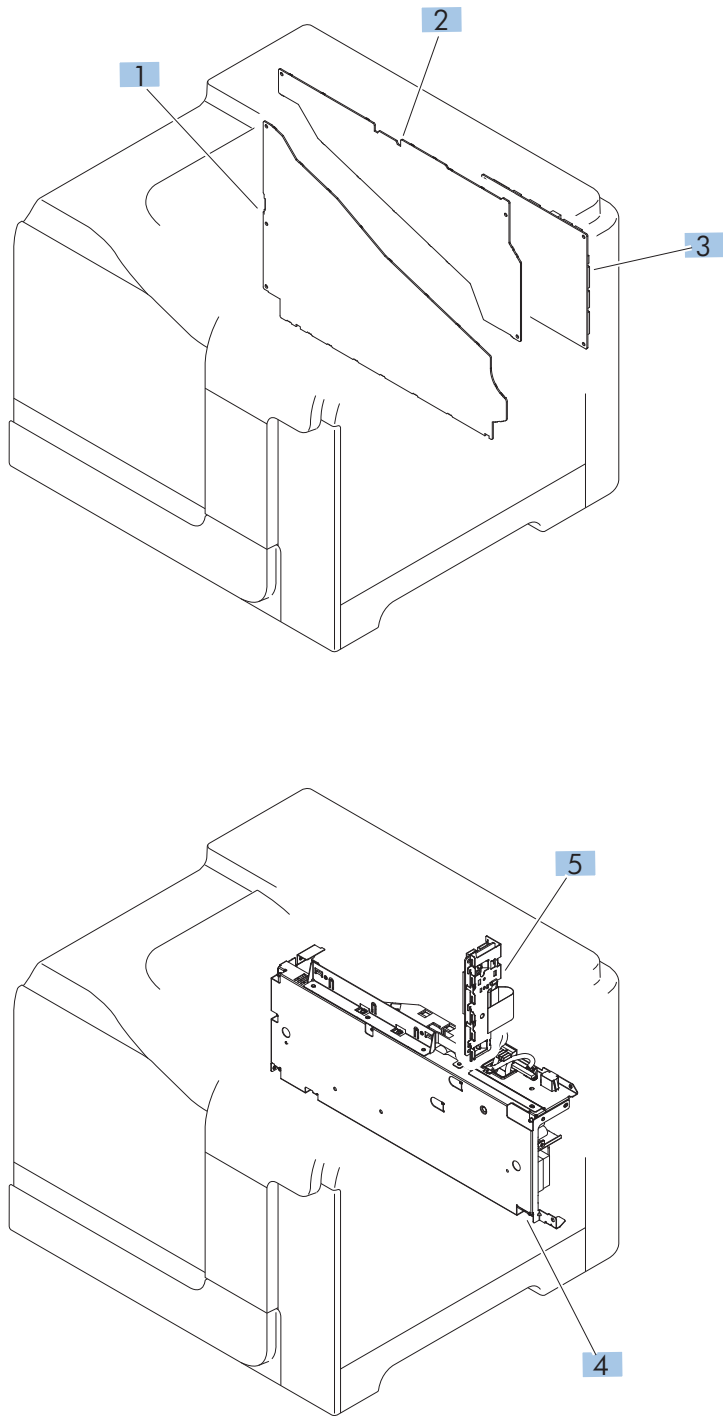

Table 2-21 PCAs

Ref	Description	Part number	Qty
1	Lower HVPS-D PCA	RM1-8087-000CN	1
2	Upper HVPS-T PCA	RM1-8088-000CN	1
3	DC controller PCA	RM1-8104-000CN	1
4	Low-voltage power supply 110V	RM1-8102-000CN	1
4	Low-voltage power supply 220V	RM1-8103-000CN	1
5	Inner connecting PCA (ICB)	RM1-8143-000CN	1
Not shown	Formatter assembly kit (New)	CD644-67909	1
Not shown	Formatter assembly kit (China)	CD644-67910	1

Assessories

1 x 500-sheet paper feeder

Figure 2-20 1 x 500-sheet paper feeder

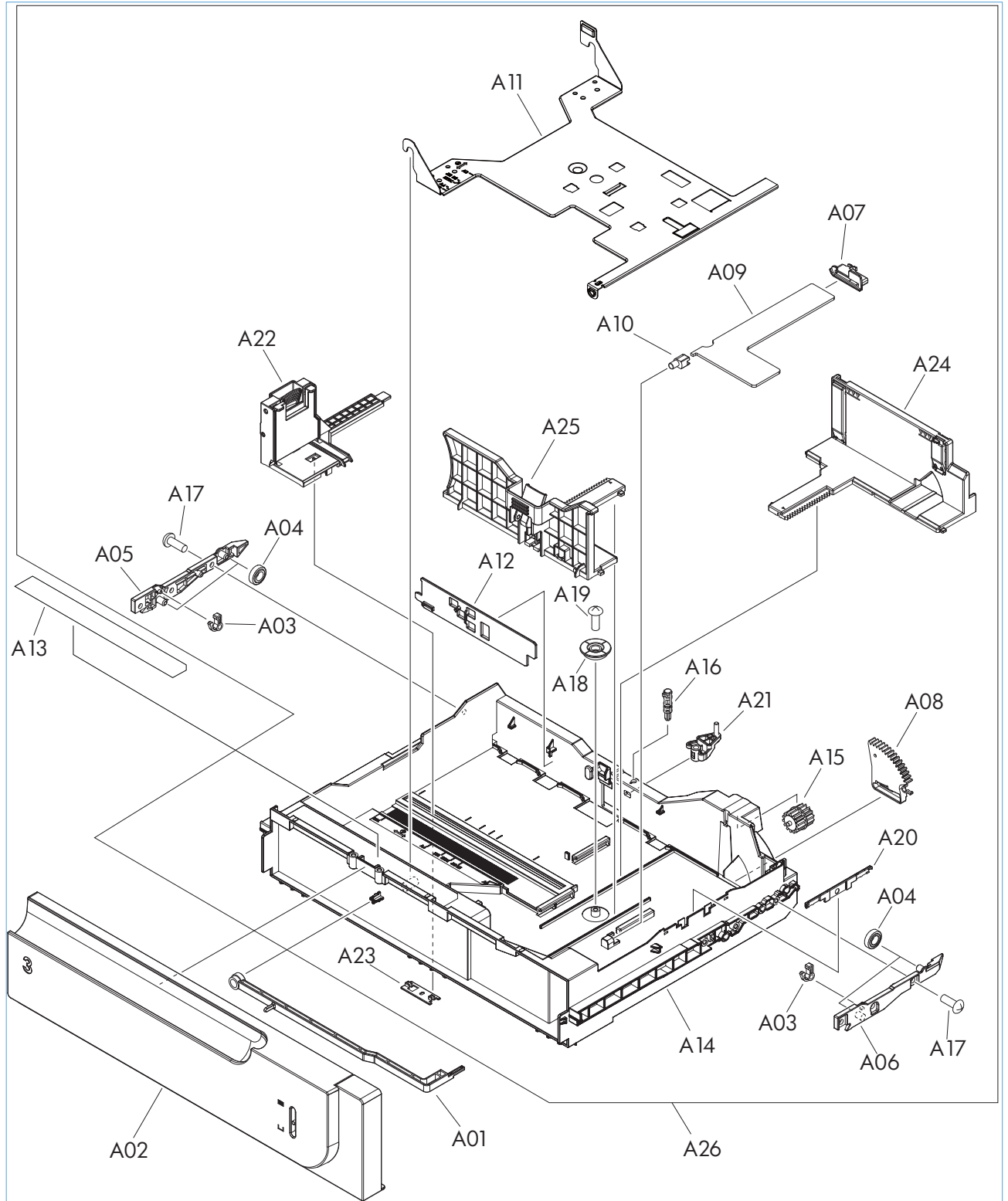

Table 2-22 1 x 500-sheet paper feeder

Ref	Description	Part number	Qty
1	1 x 500-sheet feeder replacement kit	CF084-67901	1

Paper feeder covers

Figure 2-21 Paper feeder covers

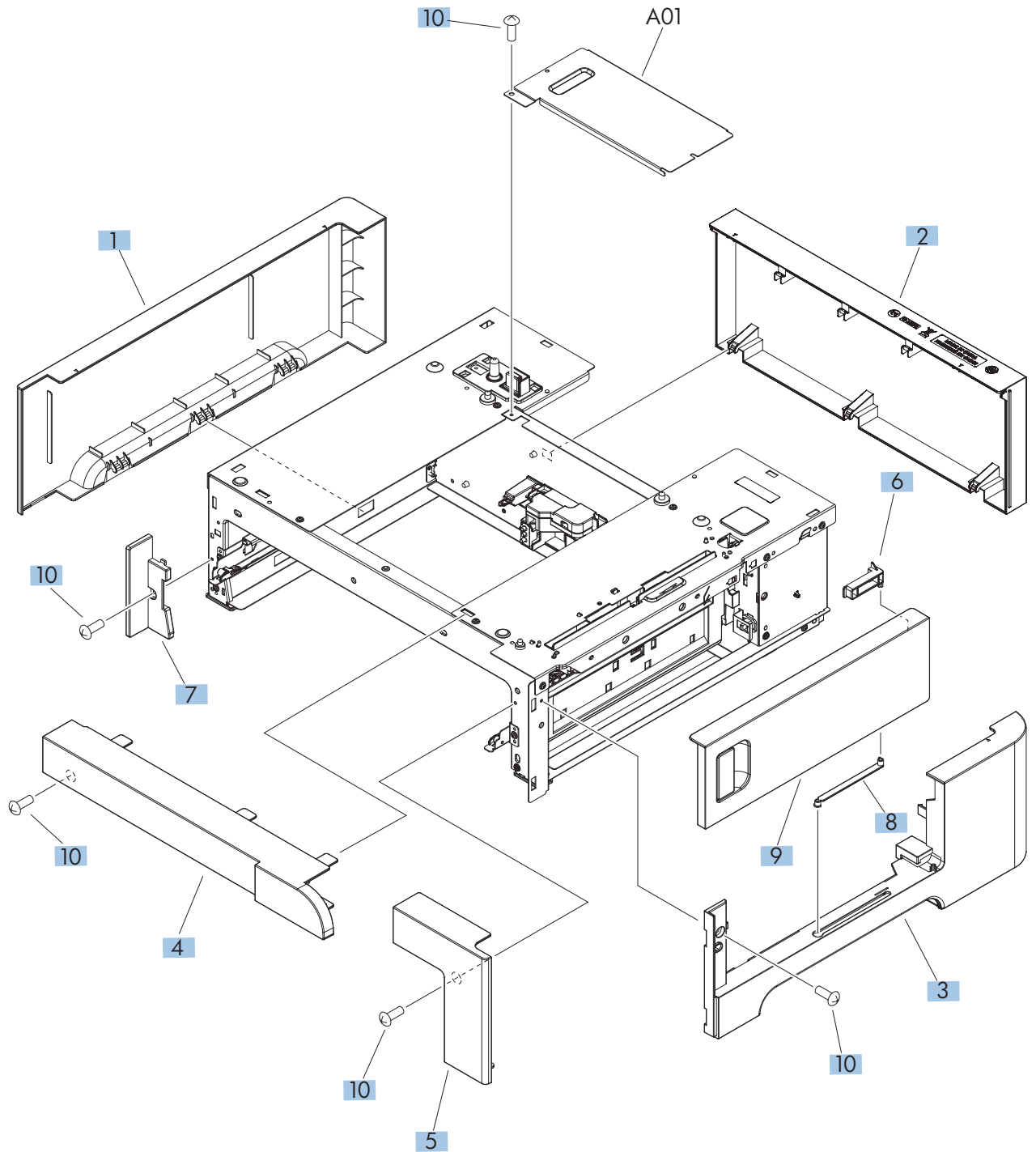

Table 2-23 Paper feeder covers

Ref	Description	Part number	Qty
1	Cover, left	RC2-5428-000CN	1
2	Cover, rear	RC2-5429-000CN	1
3	Cover, right	RC2-5427-000CN	1
4	Cover, front upper	RC2-5425-000CN	1
5	Cover, front right	RC2-5426-000CN	1
6	Stopper, door	RC2-5417-000CN	1
7	Cover, left front	RC2-5430-000CN	1
8	Link, door right	RC2-5435-000CN	1
9	Right door assembly	CC468-67906	1

Table 2-24 Paper feeder main body

Ref	Description	Part number	Qty
1	Lifter base assembly	RM1-5913-000CN	1
2	Paper feed assembly	RM1-6194-030CN	1
4	Paper pickup assembly	RM1-5919-000CN	1
5	Paper feed roller assembly	CD644-67904	1
6	Roller, paper pickup	CD644-67904	1
13	Drawer connector	VS1-7257-007CN	1
14	Holder, drawer connector	RC2-5416-000CN	1

Paper feeder cassette

Figure 2-23 Paper feeder cassette

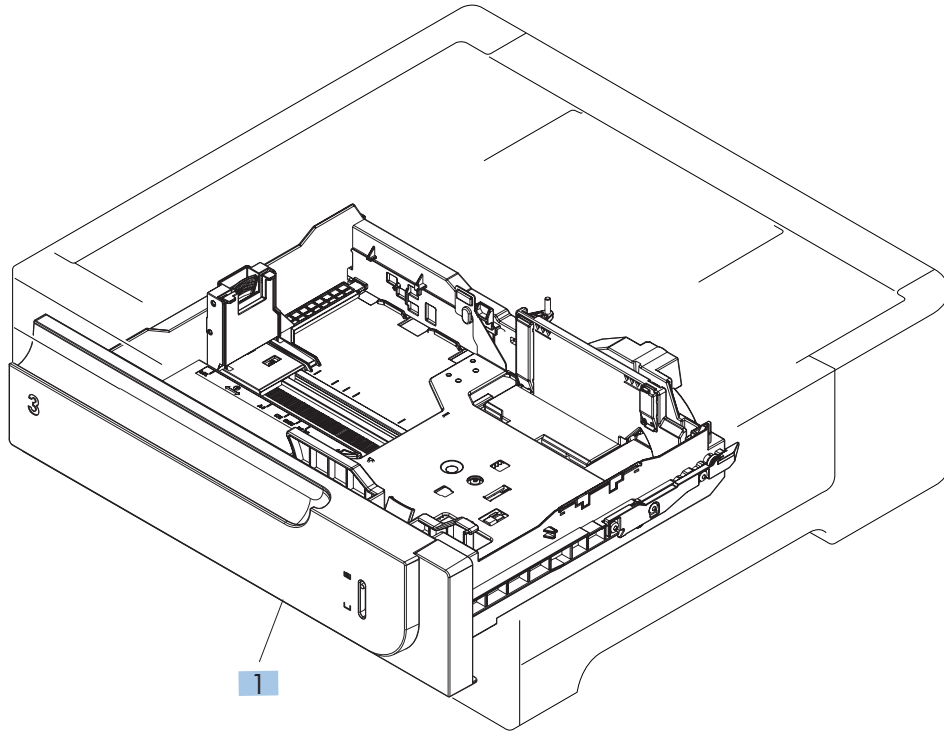

Table 2-25 Paper feeder cassette

Ref	Description	Part number	Qty
1	Cassette, Tray 3	RM1-6198-000CN	1
All shown	Optional 1 x 500-sheet feeder	CF084-67901	1

Paper feeder PCA

Figure 2-24 Paper feeder PCA

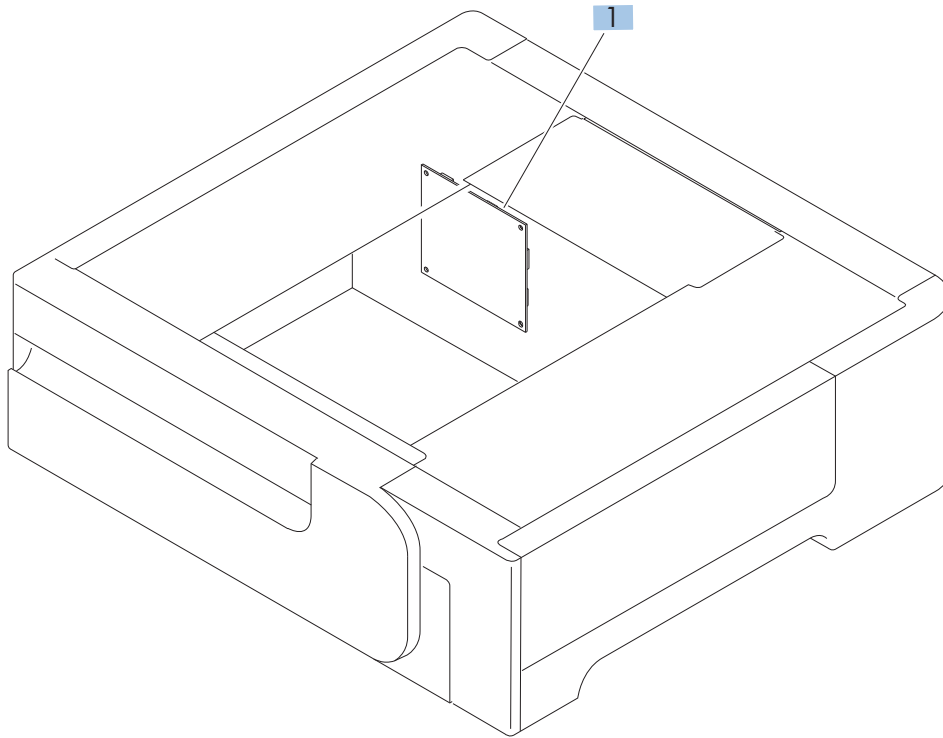

Table 2-26 Paper feeder PCA

Ref	Description	Part number	Qty
1	PCA, paper feeder driver (1 x 500)	RM1-5839-000CN	1

Alphabetical parts list

Table 2-27 Alphabetical parts list

Description	Part number	Table and page
1 x 500-sheet feeder replacement kit	CF084-67901	1 x 500-sheet paper feeder on page 301
ADF hinge assembly	Q7404-60024	ADF assemblies on page 277
ADF roller cover	CC355-40013	ADF assemblies on page 277
ADF separation pad spring	5851-4879	ADF assemblies on page 277
ADF tray extender	Q7404-40020	ADF assemblies on page 277
ADF whole unit	CD644-67918	Document feeder and scanner assemblies (M575dn and 575f models) on page 269
Arm, interlock link switch	RC2-5121-000CN	Internal assemblies (3 of 6) on page 287
Arm, shutter front	RC2-4406-000CN	Internal assemblies (2 of 6) on page 285
Arm, shutter rear	RC2-4407-030CN	Internal assemblies (2 of 6) on page 285
Base assembly	RM1-8149-000CN	Internal assemblies (2 of 6) on page 285
Button, power supply	RL1-1947-000CN	Internal assemblies (3 of 6) on page 287
Cable harness merge assy	Q7404-50005	Scanner assemblies on page 279
Cable, laser FCC 1	RK2-3941-000CN	Internal assemblies (5 of 6) on page 291
Cable, laser FCC 2	RK2-3943-000CN	Internal assemblies (5 of 6) on page 291
Cable, MP sensor assembly	RM1-5737-000CN	Internal assemblies (5 of 6) on page 291
Cable, rear assembly	RM1-8084-000CN	Internal assemblies (5 of 6) on page 291
Cartridge lock lever holder	RC2-5957-000CN	Internal assemblies (2 of 6) on page 285
Cartridge lock lever holder	RC3-1075-000CN	Internal assemblies (2 of 6) on page 285
Cartridge lock lever holder	RC2-5956-000CN	Internal assemblies (2 of 6) on page 285
Cassette, Tray 3	RM1-6198-000CN	Paper feeder cassette on page 307

Table 2-27 Alphabetical parts list (continued)

Description	Part number	Table and page
Cave light	CF116-60104	Scanner assemblies on page 279
Connecting cable assembly	RM1-5749-000CN	Internal assemblies (2 of 6) on page 285
Connector, drawer	VS1-7258-007CN	Internal assemblies (6 of 6) on page 293
Control panel	CD644-67916	Document feeder and scanner assemblies (M575dn and 575f models) on page 269
Control panel assembly kit, 575c	CD644-67920	Control panel assembly on page 275
Control panel assembly kit, 575dn and 575f	CD644-67916	Control panel assembly on page 275
Control panel cover assembly	RM1-9198-000CN	External covers, panels, and doors on page 267
Control panel, M575c	CD644-67920	Document feeder and scanner assemblies (M575dn and 575f models) on page 269
Control-panel FFC, 575c	CD644-60113	Control panel assembly on page 275
Cover	RC2-5912-000CN	Internal assemblies (2 of 6) on page 285
Cover	RC2-5962-000CN	Internal assemblies (2 of 6) on page 285
Cover, ADF cable	5851-0630	Scanner assemblies on page 279
Cover, ADF front	Q7404-40030	ADF assemblies on page 277
Cover, ADF rear	Q7404-40007	ADF assemblies on page 277
Cover, front inner lower	RL1-1915-000CN	Internal assemblies (1 of 6) on page 283
Cover, front inner lower unit	RL1-1914-020CN	Internal assemblies (1 of 6) on page 283
Cover, front inner upper	RC3-1070-000CN	Internal assemblies (1 of 6) on page 283
Cover, front right	RC2-5426-000CN	Paper feeder covers on page 303
Cover, front upper	RC2-5425-000CN	Paper feeder covers on page 303
Cover, hatch	Q7404-40006	ADF assemblies on page 277

Table 2-27 Alphabetical parts list (continued)

Description	Part number	Table and page
Cover, image scanner unit	RRC3-2097-000CN	External covers, panels, and doors on page 267
Cover, inner right lower	RC2-5019-000CN	Internal assemblies (3 of 6) on page 287
Cover, left	RC2-5052-000CN	External covers, panels, and doors on page 267
Cover, left	RC2-5428-000CN	Paper feeder covers on page 303
Cover, left front	RC2-5430-000CN	Paper feeder covers on page 303
Cover, left lower	RC2-5069-000CN	External covers, panels, and doors on page 267
Cover, left rear	RC3-2094-000CN	External covers, panels, and doors on page 267
Cover, rear	RC2-5048-000CN	External covers, panels, and doors on page 267
Cover, rear	RC2-5429-000CN	Paper feeder covers on page 303
Cover, rear right	RC2-5057-000CN	External covers, panels, and doors on page 267
Cover, rear scanner	CD644-40001	Scanner assemblies on page 279
Cover, right	RC3-2095-000CN	External covers, panels, and doors on page 267
Cover, right	RC2-5427-000CN	Paper feeder covers on page 303
Cover, right door gear rear	RC2-4924-000CN	External covers, panels, and doors on page 267
Cover, right front	RC2-5056-000CN	External covers, panels, and doors on page 267
Cover, right lower	RC2-5059-000CN	External covers, panels, and doors on page 267
Cover, right rear	RC3-2096-000CN	External covers, panels, and doors on page 267
Cover, stapler switch	RC3-2116-000CN	Internal assemblies (1 of 6) on page 283
Cover, stapler unit	RM1-9199-000CN	External covers, panels, and doors on page 267
Cover, upper rear	RC3-2092-000CN	External covers, panels, and doors on page 267

Table 2-27 Alphabetical parts list (continued)

Description	Part number	Table and page
Cover, upper right	RC3-2093-000CN	External covers, panels, and doors on page 267
DC Controller	RM1-8119-000CN	Internal assemblies (5 of 6) on page 291
DC controller PCA	RM1-8104-000CN	PCAs on page 299
Density detect assembly	RM1-8163-000CN	Internal assemblies (3 of 6) on page 287
Document feeder whole unit, M575c	CD644-67921	Document feeder and scanner assemblies (M575dn and 575f models) on page 269
Door switch assembly (SW2)	RM1-5732-000CN	Internal assemblies (3 of 6) on page 287
Drawer connector	VS1-7257-007CN	Paper feeder main body on page 305
Duplex drive assembly	RM1-4973-000CN	Internal assemblies (6 of 6) on page 293
Duplexing paper feed assembly	RM1-4959-000CN	Right-door assembly on page 281
Duplexing unit cable assembly	RM1-5730-000CN	Internal assemblies (6 of 6) on page 293
e-Duplex assembly, document feeder, M575c	5851-5022	Document feeder and scanner assemblies (M575dn and 575f models) on page 269
Fan (FM1)	RK2-2416-000CN	Internal assemblies (5 of 6) on page 291
Fan (FM2, FM3)	RK2-2418-000CN	Internal assemblies (2 of 6) on page 285
Fan cable assembly	RM1-5746-000CN	Internal assemblies (2 of 6) on page 285
FFC, control-panel keyboard, M575c	CD644-60113	Document feeder and scanner assemblies (M575dn and 575f models) on page 269
Formatter assembly kit (China)	CD644-67910	PCAs on page 299
Formatter assembly kit (New)	CD644-67909	PCAs on page 299
Front door assembly; 575c model	CD646-67904	External covers, panels, and doors on page 267
Front door assembly; 575dn and 575f models	CD644-67902	External covers, panels, and doors on page 267
Front lock arm assembly	RM1-5532-000CN	Internal assemblies (3 of 6) on page 287

Table 2-27 Alphabetical parts list (continued)

Description	Part number	Table and page
Fuser 110v	CD644-67906	Internal assemblies (3 of 6) on page 287
Fuser 220v	CD644-67907	Internal assemblies (3 of 6) on page 287
Fusing connecting cable assembly	RM1-5714-000CN	Internal assemblies (5 of 6) on page 291
Fusing drive assembly	RM1-8134-000CN	Internal assemblies (6 of 6) on page 293
Fusing motor assembly (M2)	RM1-4983-000CN	Internal assemblies (6 of 6) on page 293
Guide, cable	RC3-2103-000CN	External covers, panels, and doors on page 267
Guide, door latch right	RC2-4914-000CN	Internal assemblies (1 of 6) on page 283
Guide, light	RC2-4426-000CN	Internal assemblies (1 of 6) on page 283
Guide, option entrance	RC2-4915-000CN	Internal assemblies (3 of 6) on page 287
Holder, cartridge lock lever	RC2-5955-000CN	Internal assemblies (2 of 6) on page 285
Holder, drawer connector	RC2-5416-000CN	Paper feeder main body on page 305
Inner connecting PCA (ICB)	RM1-8143-000CN	PCAs on page 299
Interconnect PCA (ICB)	RM1-8086-000CN	Internal assemblies (5 of 6) on page 291
ITB kit	CD644-67908	Internal assemblies (3 of 6) on page 287
Keyboard assembly English, M575c	5851-5380	Keyboard and brackets on page 273
Keyboard assembly United Kingdom, M575c	5851-5008	Keyboard and brackets on page 273
Kit, Tray 1 roller (pickup roller and separation pad)	CD644-67903	Right-door assembly on page 281
Left cable assembly	RM1-5742-000CN	Internal assemblies (1 of 6) on page 283
Lever, box presence detect	RC2-5951-000CN	Internal assemblies (1 of 6) on page 283
Lever, cartridge lock lever	RC2-5954-000CN	Internal assemblies (2 of 6) on page 285

Table 2-27 Alphabetical parts list (continued)

Description	Part number	Table and page
Lever, cartridge pressure front	RC2-3983-030CN	Internal assemblies (1 of 6) on page 283
Lever, shutter	RC2-4415-000CN	Internal assemblies (2 of 6) on page 285
Lever, switch	RC3-1208-000CN	Internal assemblies (3 of 6) on page 287
Lifter base assembly	RM1-5913-000CN	Paper feeder main body on page 305
Lifter drive assembly	RM1-4976-000CN	Internal assemblies (6 of 6) on page 293
Link, door right	RC2-5435-000CN	Paper feeder covers on page 303
Link, door stopper	RC2-4916-000CN	Internal assemblies (3 of 6) on page 287
Link, door stopper	RC2-4916-000CN	Internal assemblies (5 of 6) on page 291
Link, interlock	RC2-5119-000CN	Internal assemblies (3 of 6) on page 287
Link, interlock	RC2-5118-000CN	Internal assemblies (3 of 6) on page 287
Link, interlock (SW1)	RC2-5120-000CN	Internal assemblies (3 of 6) on page 287
Lock, door	RC2-5937-000CN	Internal assemblies (1 of 6) on page 283
Low-voltage power supply 110V	RM1-8102-000CN	PCAs on page 299
Low-voltage power supply 220V	RM1-8103-000CN	PCAs on page 299
Lower HVPS (D)	RM1-8087-000CN	Internal assemblies (5 of 6) on page 291
Lower HVPS-D PCA	RM1-8087-000CN	PCAs on page 299
LVPS (110V)	RM1-8102-000CN	Internal assemblies (5 of 6) on page 291
LVPS (220V)	RM1-8103-000CN	Internal assemblies (5 of 6) on page 291
Main motor unit (M3, M4, M5)	RM1-8105-000CN	Internal assemblies (6 of 6) on page 293
Microswitch (SW3)	WC4-5171-000CN	Internal assemblies (3 of 6) on page 287
Motor/sensor cable assembly	RM1-5752-000CN	Internal assemblies (2 of 6) on page 285

Table 2-27 Alphabetical parts list (continued)

Description	Part number	Table and page
Mount, interlock switch	RC2-5123-000CN	Internal assemblies (3 of 6) on page 287
Optional 1 x 500-sheet feeder	CF084-67901	Paper feeder cassette on page 307
Paper delivery assembly	RM1-4970-060CN	Internal assemblies (3 of 6) on page 287
Paper feed assembly	RM1-6194-030CN	Paper feeder main body on page 305
Paper feed roller assembly	CD644-67904	Paper feeder main body on page 305
Paper pick up assembly	RM1-4967-000CN	Internal assemblies (3 of 6) on page 287
Paper pick up drive assembly	RM1-8135-000CN	Internal assemblies (6 of 6) on page 293
Paper pickup assembly	RM1-4967-000CN	Paper pickup assembly (Tray 2) on page 297
Paper pickup assembly	RM1-5919-000CN	Paper feeder main body on page 305
PCA, paper feeder driver (1 x 500)	RM1-5839-000CN	Paper feeder PCA on page 309
PCA, scanner control board	CD644-67926	Document feeder and scanner assemblies (M575dn and 575f models) on page 269
PCA, scanner control board, M575c	CD646-67902	Document feeder and scanner assemblies (M575dn and 575f models) on page 269
PCA, scanner memory	CD644-67924	Scanner assemblies on page 279
Photo interrupter (SR5)	WG8-5935-000CN	Internal assemblies (6 of 6) on page 293
Photointerrupter	WG8-5935-000CN	Paper pickup assembly (Tray 2) on page 297
Pick up lower guide assembly	RM1-9192-000CN	Internal assemblies (3 of 6) on page 287
Pickup motor assembly (M13)	RM1-5773-000CN	Internal assemblies (6 of 6) on page 293
Pickup roller	RM1-4968-040CN	Paper pickup assembly (Tray 2) on page 297
Plate, blanking	RC2-5938-000CN	External covers, panels, and doors on page 267

Table 2-27 Alphabetical parts list (continued)

Description	Part number	Table and page
Rear handle	RC2-5042-000CN	Internal assemblies (5 of 6) on page 291
Rear lock arm assembly	RM1-5533-000CN	Internal assemblies (3 of 6) on page 287
Rear Pre-exposure PCA assembly	RM1-8174-000CN	Internal assemblies (6 of 6) on page 293
Registration assembly	RM1-4969-000CN	Internal assemblies (3 of 6) on page 287
Right door assembly	RM1-8123-000CN	Right-door assembly on page 281
Right door assembly	CC468-67906	Paper feeder covers on page 303
Roller, paper pickup	CD644-67904	Paper feeder main body on page 305
Scanner whole unit	CD644-67922	Document feeder and scanner assemblies (M575dn and 575f models) on page 269
Scanner whole unit, M575c	CD646-67901	Document feeder and scanner assemblies (M575dn and 575f models) on page 269
Secondary transfer assembly	RM1-4952-030CN	Internal assemblies (3 of 6) on page 287
Secondary transfer roller	CD644-67914	Internal assemblies (3 of 6) on page 287
Sensor cable assembly	RM1-5740-000CN	Internal assemblies (2 of 6) on page 285
Sensor cable assembly	RM1-5741-000CN	Internal assemblies (2 of 6) on page 285
Sensor cable guide assembly (SR7)	RM1-8178-000CN	Internal assemblies (3 of 6) on page 287
Separation roller assembly (part of roller kit)	CD644-67904	Tray 2 on page 295
Separation roller assy (part of roller kit)	RM1-4966-020CN	Internal assemblies (2 of 6) on page 285
Shaft	RC2-5913-000CN	Internal assemblies (3 of 6) on page 287
Shutter assembly	RM1-4999-000CN	Internal assemblies (2 of 6) on page 285
Shutter assembly	RM1-5488-000CN	Internal assemblies (2 of 6) on page 285
Spring	RC3-1212-000CN	Internal assemblies (3 of 6) on page 287

Table 2-27 Alphabetical parts list (continued)

Description	Part number	Table and page
Spring, compression	RU6-2567-000CN	Internal assemblies (1 of 6) on page 283
Spring, compression	RU6-2568-000CN	Internal assemblies (1 of 6) on page 283
Spring, compression	RU6-2318-000CN	Internal assemblies (2 of 6) on page 285
Spring, compression	RU6-2316-000CN	Internal assemblies (2 of 6) on page 285
Spring, compression	RC2-5021-000CN	Internal assemblies (5 of 6) on page 291
Spring, compression	RU7-2193-000CN	Internal assemblies (6 of 6) on page 293
Spring, ground	RU6-2237-000CN	Internal assemblies (1 of 6) on page 283
Spring, grounding	RC2-5148-000CN	Internal assemblies (5 of 6) on page 291
Spring, tension	RU7-2192-000CN	Internal assemblies (1 of 6) on page 283
Spring, tension	RU6-2436-000CN	Internal assemblies (2 of 6) on page 285
Spring, tension	RU6-2405-000CN	Internal assemblies (6 of 6) on page 293
Spring, torsion	RC2-5958-000CN	Internal assemblies (2 of 6) on page 285
Spring, torsion	RC2-4378-000CN	Internal assemblies (3 of 6) on page 287
Spring, torsion	RU6-2268-000CN	Internal assemblies (3 of 6) on page 287
Spring, torsion	RC2-4377-000CN	Internal assemblies (3 of 6) on page 287
Spring, torsion	RC2-5122-000CN	Internal assemblies (3 of 6) on page 287
Stand assembly	RM1-5588-000CN	Internal assemblies (2 of 6) on page 285
Stepping motor, DC (M10)	RK2-2415-000CN	Internal assemblies (6 of 6) on page 293
Stopper, door	RC2-5417-000CN	Paper feeder covers on page 303
Switch arm	RC2-5943-000CN	Internal assemblies (5 of 6) on page 291

Table 2-27 Alphabetical parts list (continued)

Description	Part number	Table and page
Switch cable assembly	RM1-8065-000CN	Internal assemblies (3 of 6) on page 287
Switch PCA assembly	RM1-8097-000CN	Internal assemblies (3 of 6) on page 287
Temperature sensor unit	RK2-3267-000CN	Internal assemblies (2 of 6) on page 285
Toner collection unit (TCU)	RM1-4989-000CN	Internal assemblies (1 of 6) on page 283
Toner sensor holder assembly	RM1-5700-000CN	Internal assemblies (2 of 6) on page 285
Tray 2	RM1-4962-060CN	Internal assemblies (2 of 6) on page 285
Tray 2	RM1-6198-000CN	Tray 2 on page 295
Tray, paper delivery	RL1-1941-030CN	External covers, panels, and doors on page 267
Upper HVPS (T)	RM1-8088-000CN	Internal assemblies (5 of 6) on page 291
Upper HVPS-T PCA	RM1-8088-000CN	PCAs on page 299
Waste toner box seal	RC2-4780-000CN	Internal assemblies (1 of 6) on page 283
Waste toner detect assembly	RM1-5696-000CN	Internal assemblies (1 of 6) on page 283
Waste toner duct assembly	RM1-8138-000CN	Internal assemblies (1 of 6) on page 283
Wire (mech) sensor project	RC2-4828-000CN	Internal assemblies (3 of 6) on page 287

Numerical parts list

Table 2-28 Numerical parts list

Part number	Description	Table and page
5851-0630	Cover, ADF cable	Scanner assemblies on page 279
5851-4879	ADF separation pad spring	ADF assemblies on page 277
5851-5008	Keyboard assembly United Kingdom, M575c	Keyboard and brackets on page 273
5851-5022	e-Duplex assembly, document feeder, M575c	Document feeder and scanner assemblies (M575dn and 575f models) on page 269
5851-5380	Keyboard assembly English, M575c	Keyboard and brackets on page 273
CC355-40013	ADF roller cover	ADF assemblies on page 277
CC468-67906	Right door assembly	Paper feeder covers on page 303
CD644-40001	Cover, rear scanner	Scanner assemblies on page 279
CD644-60113	FFC, control-panel keyboard, M575c	Document feeder and scanner assemblies (M575dn and 575f models) on page 269
CD644-60113	Control-panel FFC, 575c	Control panel assembly on page 275
CD644-67902	Front door assembly; 575dn and 575f models	External covers, panels, and doors on page 267
CD644-67903	Kit, Tray 1 roller (pickup roller and separation pad)	Right-door assembly on page 281
CD644-67904	Separation roller assembly (part of roller kit)	Tray 2 on page 295
CD644-67904	Paper feed roller assembly	Paper feeder main body on page 305
CD644-67904	Roller, paper pickup	Paper feeder main body on page 305
CD644-67906	Fuser 110v	Internal assemblies (3 of 6) on page 287
CD644-67907	Fuser 220v	Internal assemblies (3 of 6) on page 287
CD644-67908	ITB kit	Internal assemblies (3 of 6) on page 287
CD644-67909	Formatter assembly kit (New)	PCAs on page 299
CD644-67910	Formatter assembly kit (China)	PCAs on page 299

Table 2-28 Numerical parts list (continued)

Part number	Description	Table and page
CD644-67914	Secondary transfer roller	Internal assemblies (3 of 6) on page 287
CD644-67916	Control panel	Document feeder and scanner assemblies (M575dn and 575f models) on page 269
CD644-67916	Control panel assembly kit, 575dn and 575f	Control panel assembly on page 275
CD644-67918	ADF whole unit	Document feeder and scanner assemblies (M575dn and 575f models) on page 269
CD644-67920	Control panel, M575c	Document feeder and scanner assemblies (M575dn and 575f models) on page 269
CD644-67920	Control panel assembly kit, 575c	Control panel assembly on page 275
CD644-67921	Document feeder whole unit, M575c	Document feeder and scanner assemblies (M575dn and 575f models) on page 269
CD644-67922	Scanner whole unit	Document feeder and scanner assemblies (M575dn and 575f models) on page 269
CD644-67924	PCA, scanner memory	Scanner assemblies on page 279
CD644-67926	PCA, scanner control board	Document feeder and scanner assemblies (M575dn and 575f models) on page 269
CD646-67901	Scanner whole unit, M575c	Document feeder and scanner assemblies (M575dn and 575f models) on page 269
CD646-67902	PCA, scanner control board, M575c	Document feeder and scanner assemblies (M575dn and 575f models) on page 269
CD646-67904	Front door assembly; 575c model	External covers, panels, and doors on page 267
CF084-67901	1 x 500-sheet feeder replacement kit	1 x 500-sheet paper feeder on page 301
CF084-67901	Optional 1 x 500-sheet feeder	Paper feeder cassette on page 307
CF116-60104	Cave light	Scanner assemblies on page 279
Q7404-40006	Cover, hatch	ADF assemblies on page 277
Q7404-40007	Cover, ADF rear	ADF assemblies on page 277

Table 2-28 Numerical parts list (continued)

Part number	Description	Table and page
Q7404-40020	ADF tray extender	ADF assemblies on page 277
Q7404-40030	Cover, ADF front	ADF assemblies on page 277
Q7404-50005	Cable harness merge assy	Scanner assemblies on page 279
Q7404-60024	ADF hinge assembly	ADF assemblies on page 277
RC2-3983-030CN	Lever, cartridge pressure front	Internal assemblies (1 of 6) on page 283
RC2-4377-000CN	Spring, torsion	Internal assemblies (3 of 6) on page 287
RC2-4378-000CN	Spring, torsion	Internal assemblies (3 of 6) on page 287
RC2-4406-000CN	Arm, shutter front	Internal assemblies (2 of 6) on page 285
RC2-4407-030CN	Arm, shutter rear	Internal assemblies (2 of 6) on page 285
RC2-4415-000CN	Lever, shutter	Internal assemblies (2 of 6) on page 285
RC2-4426-000CN	Guide, light	Internal assemblies (1 of 6) on page 283
RC2-4780-000CN	Waste toner box seal	Internal assemblies (1 of 6) on page 283
RC2-4828-000CN	Wire (mech) sensor project	Internal assemblies (3 of 6) on page 287
RC2-4914-000CN	Guide, door latch right	Internal assemblies (1 of 6) on page 283
RC2-4915-000CN	Guide, option entrance	Internal assemblies (3 of 6) on page 287
RC2-4916-000CN	Link, door stopper	Internal assemblies (3 of 6) on page 287
RC2-4916-000CN	Link, door stopper	Internal assemblies (5 of 6) on page 291
RC2-4924-000CN	Cover, right door gear rear	External covers, panels, and doors on page 267
RC2-5019-000CN	Cover, inner right lower	Internal assemblies (3 of 6) on page 287
RC2-5021-000CN	Spring, compression	Internal assemblies (5 of 6) on page 291
RC2-5042-000CN	Rear handle	Internal assemblies (5 of 6) on page 291

Table 2-28 Numerical parts list (continued)

Part number	Description	Table and page
RC2-5048-000CN	Cover, rear	External covers, panels, and doors on page 267
RC2-5052-000CN	Cover, left	External covers, panels, and doors on page 267
RC2-5056-000CN	Cover, right front	External covers, panels, and doors on page 267
RC2-5057-000CN	Cover, rear right	External covers, panels, and doors on page 267
RC2-5059-000CN	Cover, right lower	External covers, panels, and doors on page 267
RC2-5069-000CN	Cover, left lower	External covers, panels, and doors on page 267
RC2-5118-000CN	Link, interlock	Internal assemblies (3 of 6) on page 287
RC2-5119-000CN	Link, interlock	Internal assemblies (3 of 6) on page 287
RC2-5120-000CN	Link, interlock (SW1)	Internal assemblies (3 of 6) on page 287
RC2-5121-000CN	Arm, interlock link switch	Internal assemblies (3 of 6) on page 287
RC2-5122-000CN	Spring, torsion	Internal assemblies (3 of 6) on page 287
RC2-5123-000CN	Mount, interlock switch	Internal assemblies (3 of 6) on page 287
RC2-5148-000CN	Spring, grounding	Internal assemblies (5 of 6) on page 291
RC2-5416-000CN	Holder, drawer connector	Paper feeder main body on page 305
RC2-5417-000CN	Stopper, door	Paper feeder covers on page 303
RC2-5425-000CN	Cover, front upper	Paper feeder covers on page 303
RC2-5426-000CN	Cover, front right	Paper feeder covers on page 303
RC2-5427-000CN	Cover, right	Paper feeder covers on page 303
RC2-5428-000CN	Cover, left	Paper feeder covers on page 303
RC2-5429-000CN	Cover, rear	Paper feeder covers on page 303

Table 2-28 Numerical parts list (continued)

Part number	Description	Table and page
RC2-5430-000CN	Cover, left front	Paper feeder covers on page 303
RC2-5435-000CN	Link, door right	Paper feeder covers on page 303
RC2-5912-000CN	Cover	Internal assemblies (2 of 6) on page 285
RC2-5913-000CN	Shaft	Internal assemblies (3 of 6) on page 287
RC2-5937-000CN	Lock, door	Internal assemblies (1 of 6) on page 283
RC2-5938-000CN	Plate, blanking	External covers, panels, and doors on page 267
RC2-5943-000CN	Switch arm	Internal assemblies (5 of 6) on page 291
RC2-5951-000CN	Lever, box presence detect	Internal assemblies (1 of 6) on page 283
RC2-5954-000CN	Lever, cartridge lock lever	Internal assemblies (2 of 6) on page 285
RC2-5955-000CN	Holder, cartridge lock lever	Internal assemblies (2 of 6) on page 285
RC2-5956-000CN	Cartridge lock lever holder	Internal assemblies (2 of 6) on page 285
RC2-5957-000CN	Cartridge lock lever holder	Internal assemblies (2 of 6) on page 285
RC2-5958-000CN	Spring, torsion	Internal assemblies (2 of 6) on page 285
RC2-5962-000CN	Cover	Internal assemblies (2 of 6) on page 285
RC3-1070-000CN	Cover, front inner upper	Internal assemblies (1 of 6) on page 283
RC3-1075-000CN	Cartridge lock lever holder	Internal assemblies (2 of 6) on page 285
RC3-1208-000CN	Lever, switch	Internal assemblies (3 of 6) on page 287
RC3-1212-000CN	Spring	Internal assemblies (3 of 6) on page 287
RC3-2092-000CN	Cover, upper rear	External covers, panels, and doors on page 267
RC3-2093-000CN	Cover, upper right	External covers, panels, and doors on page 267

Table 2-28 Numerical parts list (continued)

Part number	Description	Table and page
RC3-2094-000CN	Cover, left rear	External covers, panels, and doors on page 267
RC3-2095-000CN	Cover, right	External covers, panels, and doors on page 267
RC3-2096-000CN	Cover, right rear	External covers, panels, and doors on page 267
RC3-2103-000CN	Guide, cable	External covers, panels, and doors on page 267
RC3-2116-000CN	Cover, stapler switch	Internal assemblies (1 of 6) on page 283
RK2-2415-000CN	Stepping motor, DC (M10)	Internal assemblies (6 of 6) on page 293
RK2-2416-000CN	Fan (FM1)	Internal assemblies (5 of 6) on page 291
RK2-2418-000CN	Fan (FM2, FM3)	Internal assemblies (2 of 6) on page 285
RK2-3267-000CN	Temperature sensor unit	Internal assemblies (2 of 6) on page 285
RK2-3941-000CN	Cable, laser FCC 1	Internal assemblies (5 of 6) on page 291
RK2-3943-000CN	Cable, laser FCC 2	Internal assemblies (5 of 6) on page 291
RL1-1914-020CN	Cover, front inner lower unit	Internal assemblies (1 of 6) on page 283
RL1-1915-000CN	Cover, front inner lower	Internal assemblies (1 of 6) on page 283
RL1-1941-030CN	Tray, paper delivery	External covers, panels, and doors on page 267
RL1-1947-000CN	Button, power supply	Internal assemblies (3 of 6) on page 287
RM1-4952-030CN	Secondary transfer assembly	Internal assemblies (3 of 6) on page 287
RM1-4959-000CN	Duplexing paper feed assembly	Right-door assembly on page 281
RM1-4962-060CN	Tray 2	Internal assemblies (2 of 6) on page 285
RM1-4966-020CN	Separation roller assy (part of roller kit)	Internal assemblies (2 of 6) on page 285
RM1-4967-000CN	Paper pick up assembly	Internal assemblies (3 of 6) on page 287

Table 2-28 Numerical parts list (continued)

Part number	Description	Table and page
RM1-4967-000CN	Paper pickup assembly	Paper pickup assembly (Tray 2) on page 297
RM1-4968-040CN	Pickup roller	Paper pickup assembly (Tray 2) on page 297
RM1-4969-000CN	Registration assembly	Internal assemblies (3 of 6) on page 287
RM1-4970-060CN	Paper delivery assembly	Internal assemblies (3 of 6) on page 287
RM1-4973-000CN	Duplex drive assembly	Internal assemblies (6 of 6) on page 293
RM1-4976-000CN	Lifter drive assembly	Internal assemblies (6 of 6) on page 293
RM1-4983-000CN	Fusing motor assembly (M2)	Internal assemblies (6 of 6) on page 293
RM1-4989-000CN	Toner collection unit (TCU)	Internal assemblies (1 of 6) on page 283
RM1-4999-000CN	Shutter assembly	Internal assemblies (2 of 6) on page 285
RM1-5488-000CN	Shutter assembly	Internal assemblies (2 of 6) on page 285
RM1-5532-000CN	Front lock arm assembly	Internal assemblies (3 of 6) on page 287
RM1-5533-000CN	Rear lock arm assembly	Internal assemblies (3 of 6) on page 287
RM1-5588-000CN	Stand assembly	Internal assemblies (2 of 6) on page 285
RM1-5696-000CN	Waste toner detect assembly	Internal assemblies (1 of 6) on page 283
RM1-5700-000CN	Toner sensor holder assembly	Internal assemblies (2 of 6) on page 285
RM1-5714-000CN	Fusing connecting cable assembly	Internal assemblies (5 of 6) on page 291
RM1-5730-000CN	Duplexing unit cable assembly	Internal assemblies (6 of 6) on page 293
RM1-5732-000CN	Door switch assembly (SW2)	Internal assemblies (3 of 6) on page 287
RM1-5737-000CN	Cable, MP sensor assembly	Internal assemblies (5 of 6) on page 291
RM1-5740-000CN	Sensor cable assembly	Internal assemblies (2 of 6) on page 285

Table 2-28 Numerical parts list (continued)

Part number	Description	Table and page
RM1-5741-000CN	Sensor cable assembly	Internal assemblies (2 of 6) on page 285
RM1-5742-000CN	Left cable assembly	Internal assemblies (1 of 6) on page 283
RM1-5746-000CN	Fan cable assembly	Internal assemblies (2 of 6) on page 285
RM1-5749-000CN	Connecting cable assembly	Internal assemblies (2 of 6) on page 285
RM1-5752-000CN	Motor/sensor cable assembly	Internal assemblies (2 of 6) on page 285
RM1-5773-000CN	Pickup motor assembly (M13)	Internal assemblies (6 of 6) on page 293
RM1-5839-000CN	PCA, paper feeder driver (1 x 500)	Paper feeder PCA on page 309
RM1-5913-000CN	Lifter base assembly	Paper feeder main body on page 305
RM1-5919-000CN	Paper pickup assembly	Paper feeder main body on page 305
RM1-6194-030CN	Paper feed assembly	Paper feeder main body on page 305
RM1-6198-000CN	Tray 2	Tray 2 on page 295
RM1-6198-000CN	Cassette, Tray 3	Paper feeder cassette on page 307
RM1-8065-000CN	Switch cable assembly	Internal assemblies (3 of 6) on page 287
RM1-8084-000CN	Cable, rear assembly	Internal assemblies (5 of 6) on page 291
RM1-8086-000CN	Interconnect PCA (ICB)	Internal assemblies (5 of 6) on page 291
RM1-8087-000CN	Lower HVPS (D)	Internal assemblies (5 of 6) on page 291
RM1-8087-000CN	Lower HVPS-D PCA	PCAs on page 299
RM1-8088-000CN	Upper HVPS (T)	Internal assemblies (5 of 6) on page 291
RM1-8088-000CN	Upper HVPS-T PCA	PCAs on page 299
RM1-8097-000CN	Switch PCA assembly	Internal assemblies (3 of 6) on page 287
RM1-8102-000CN	LVPS (110V)	Internal assemblies (5 of 6) on page 291

Table 2-28 Numerical parts list (continued)

Part number	Description	Table and page
RM1-8102-000CN	Low-voltage power supply 110V	PCAs on page 299
RM1-8103-000CN	LVPS (220V)	Internal assemblies (5 of 6) on page 291
RM1-8103-000CN	Low-voltage power supply 220V	PCAs on page 299
RM1-8104-000CN	DC controller PCA	PCAs on page 299
RM1-8105-000CN	Main motor unit (M3, M4, M5)	Internal assemblies (6 of 6) on page 293
RM1-8119-000CN	DC Controller	Internal assemblies (5 of 6) on page 291
RM1-8123-000CN	Right door assembly	Right-door assembly on page 281
RM1-8134-000CN	Fusing drive assembly	Internal assemblies (6 of 6) on page 293
RM1-8135-000CN	Paper pick up drive assembly	Internal assemblies (6 of 6) on page 293
RM1-8138-000CN	Waste toner duct assembly	Internal assemblies (1 of 6) on page 283
RM1-8143-000CN	Inner connecting PCA (ICB)	PCAs on page 299
RM1-8149-000CN	Base assembly	Internal assemblies (2 of 6) on page 285
RM1-8163-000CN	Density detect assembly	Internal assemblies (3 of 6) on page 287
RM1-8174-000CN	Rear Pre-exposure PCA assembly	Internal assemblies (6 of 6) on page 293
RM1-8178-000CN	Sensor cable guide assembly (SR7)	Internal assemblies (3 of 6) on page 287
RM1-9192-000CN	Pick up lower guide assembly	Internal assemblies (3 of 6) on page 287
RM1-9198-000CN	Control panel cover assembly	External covers, panels, and doors on page 267
RM1-9199-000CN	Cover, stapler unit	External covers, panels, and doors on page 267
RRC3-2097-000CN	Cover, image scanner unit	External covers, panels, and doors on page 267
RU6-2237-000CN	Spring, ground	Internal assemblies (1 of 6) on page 283
RU6-2268-000CN	Spring, torsion	Internal assemblies (3 of 6) on page 287

Table 2-28 Numerical parts list (continued)

Part number	Description	Table and page
RU6-2316-000CN	Spring, compression	Internal assemblies (2 of 6) on page 285
RU6-2318-000CN	Spring, compression	Internal assemblies (2 of 6) on page 285
RU6-2405-000CN	Spring, tension	Internal assemblies (6 of 6) on page 293
RU6-2436-000CN	Spring, tension	Internal assemblies (2 of 6) on page 285
RU6-2567-000CN	Spring, compression	Internal assemblies (1 of 6) on page 283
RU6-2568-000CN	Spring, compression	Internal assemblies (1 of 6) on page 283
RU7-2192-000CN	Spring, tension	Internal assemblies (1 of 6) on page 283
RU7-2193-000CN	Spring, compression	Internal assemblies (6 of 6) on page 293
VS1-7257-007CN	Drawer connector	Paper feeder main body on page 305
VS1-7258-007CN	Connector, drawer	Internal assemblies (6 of 6) on page 293
WC4-5171-000CN	Microswitch (SW3)	Internal assemblies (3 of 6) on page 287
WG8-5935-000CN	Photo interrupter (SR5)	Internal assemblies (6 of 6) on page 293
WG8-5935-000CN	Photointerrupter	Paper pickup assembly (Tray 2) on page 297

Index

A

- accessories
 - ordering 254
 - part numbers 254
- after service checklist 6

B

- back-side background selector assembly (M575c model)
 - removing 76

C

- cartridges
 - removing 11
- cartridges, print
 - part numbers 255
- cassette
 - tray 2, removing 23
 - tray 3, removing 23
- cautions iii
- checklists
 - after service 6
 - preservice 6
- components
 - Registration density (RD) sensor assembly, removing 177
 - residual-toner-feed motor, removing 166
 - toner-collection sensor, removing 163
- control panel
 - removing 44
- control-panel assembly M575c model)
 - removing 47
- conventions, document iii
- covers
 - delivery cover, removing 104

- front-door assembly, removing 37
- front-top, removing 110
- front-upper cover, removing 83
- left, removing 92
- left-upper cover, removing 97
- rear cover, removing 98
- rear-toptop, removing 112
- rear-upper cover, removing 95
- right-door assembly, removing 86
- right-front, removing 100
- right-rear, removing 90
- right-top cover, removing 106
- stapler, removing 85

D

- DC controller PCA and tray, removing 150
- delivery assembly
 - removing 244
- delivery cover, removing 104
- deskew mylar
 - removing 118
- diagrams 253
- document feeder hinge assy
 - removing 132
- document feeder front cover
 - removing 114
- document feeder whole unit
 - removing 127
- document conventions iii
- document feeder jam-access cover
 - removing 121
- document feeder rear cover
 - removing 116
- document feeder roller cover
 - removing 124

- document feeder tray extender
 - removing 120
- document feeder whole unit (M575c model)
 - removing 130
- drawer connector
 - drawer connector, removing 251
- duplexing unit
 - duplex-drive assembly, removing 249

E

- electrostatic discharge (ESD) 3
- ESD (electrostatic discharge) 3

F

- fans
 - cartridge, removing 158
 - delivery, removing 158
 - power-supply fan and fan duct, removing 181
- fasteners
 - screws 262
- fax PCA, removing 18
- FFC, keyboard yto control-panel assembly
 - removing 63
- formatter
 - PCA, removing 17
- front-door assembly, removing 37
- front-top cover, removing 110
- front-upper cover, removing 83
- fuser
 - drive assembly, removing 239
 - motor, removing 227

- H**
 hardward integration pocket
 removing 82
 high-voltage power supply
 removing, lower 189
 removing, upper 221
 HIP
 removing 82
- I**
 ICB, removing 148
 image scanner whole unit
 removing 139
 intermediate transfer belt (ITB) 34
- K**
 keyboard assembly (M575c model)
 removing 68
 keyboard overlay (M575c model)
 installing 72
- L**
 laser/scanner
 assembly (C/Bk), removing
 213
 assembly (Y/M), removing
 206
 left cover, removing 92
 left-upper cover, removing 97
 lifter-drive assembly
 removing 195
 location
 optional trays or accessories
 (base product) 265
 LVPS, removing 153
- M**
 main-drive assembly
 removing 228
 motors
 developing-disengagement,
 removing 192
 drum motor 1, removing 225
 drum motor 2 or 3, removing
 226
 fuser, removing 227
 pickup, removing 194
- N**
 notes iii
- O**
 ordering
 part numbers for 254
 product documents 262
 supplies and accessories 254
- P**
 part numbers
 print cartridges 255
 screws 262
 toner collection unit 256
 parts 253
 control panel 274
 optional trays or accessories
 (base product) 265
 parts lists and diagrams
 covers 266
 internal assemblies 282, 284,
 286, 288, 290, 292
 using 263
 pliers, required 3
 post-service tests 7
 preservice checklist 6
 print cartridges
 part numbers 255
 print-quality test 7
- R**
 rear cover, removing 98
 rear-top cover, removing 112
 rear-upper cover, removing 95
 registration assembly
 removing 184
 Registration density (RD) sensor
 assembly, removing 177
 removing parts
 back-side background selector
 assembly (M575c model) 76
 cartridge fan 158
 cautions for 2
 checklists 6
 control-panel assembly M575c
 model) 47
 control-panel assembly to
 keyboard FFC 63
 DC controller PCA and tray
 150
 delivery assembly 244
 delivery cover 104
 delivery fan 158
 des skew mylar 118
 developing-disengagement
 motor 192
 document feeder whole unit
 (M575c model) 130
 document feeder F jam-access
 cover 121
 document feeder front cover
 114
 document feeder hinge assy
 132
 document feeder rear cover
 116
 document feeder roller cover
 124
 document feeder tray
 extender 120
 document feeder whole unit
 127
 drawer connector 251
 drum motor 1 225
 drum motor 2 or 3 226
 duplex-drive assembly 249
 environmental sensor 158
 fax PCA 18
 formatter PCA 17
 front-door assembly 37
 front-top cover 110
 front-upper cover 83
 fuser 24
 fuser motor 227
 fuser-drive assembly 239
 hardward integration pocket
 82
 high-voltage power supply
 lower 189
 high-voltage power supply
 upper 221
 ICB 148
 image scanner whole unit 139
 intermediate transfer belt 34
 keyboard assembly (M575c
 model) 68
 laser/scanner assembly (C/
 Bk) 213
 laser/scanner assembly (Y/
 M) 206
 left cover 92
 left-upper cover 97
 lifter-drive assembly 195

- LVPS 153
- main-drive assembly 228
- pickup motor 194
- pickup roller (tray 1) 25
- pickup roller (tray 2) 27
- power-supply fan and fan duct 181
- rear cover 98
- rear-top cover 112
- rear-upper cover 95
- registration assembly 184
- Registration density (RD) sensor assembly 177
- residual-toner-feed motor 166
- right-door assembly 86
- right-front cover 100
- right-rear cover 90
- right-top cover 106
- SCB 133, 136
- secondary transfer assembly 171
- secondary transfer roller 32
- separation mylar 118
- separation roller (tray 2) 31
- service approach 5
- stable cartridge 13
- stapler assembly 147
- stapler cover 85
- toner cartridges 11
- toner-collection sensor 163
- toner-collection unit 15
- tools, required 3
- tray 23
- tray extender 120
- tray-pickup assembly 204
- tray-pickup drive assembly 197
- USB cover 81
- repair approach 5
- replacing
 - parts 2
- replacing parts
 - service approach 5
- residual-toner-feed motor, removing 166
- right-front cover, removing 100
- right-top cover, removing 106

- roller
 - pickup roller (Tray 1), removing 25
 - pickup roller (Tray 2), removing 27
- rollers
 - secondary transfer roller, removing 171
 - separation roller (Tray 2), removing 31

S

- SCB, removing 133, 136
- screwdrivers, required 3
- screws
 - part numbers 262
 - replacing 2
 - types of 4
- secondary transfer roller, removing 32
- sensors
 - environmental, removing 158
- separation mylar
 - removing 118
- service
 - approach 5
 - tools, required 3
- stable cartridge, removing 13
- stapler assembly, removing 147
- static precautions 3
- supplies
 - ordering 254
 - part numbers 254, 255, 256

T

- TCU
 - part numbers 256
- tests
 - post-service 7
 - print-quality 7
- tips iii
- toner cartridges
 - removing 11
- toner collection unit
 - part numbers 256
 - removing 15
- toner-collection sensor, removing 163
- tools, required 3

- tray
 - pickup assembly, removing 204
 - pickup drive assembly, removing 197
- tray extender
 - removing 120
- trays
 - removing 23
- troubleshooting
 - service approach 5

U

- USB cover
 - removing 81

W

- warnings iii
- Web sites
 - ordering supplies 254



CD644-90966

