

brother®

SERVICE MANUAL

MODEL: LX-200/LX-900/LX-910D



MECHANISMS & ELECTRONICS
REVISED EDITION May, 2000

Unauthorized copying of all or part of the contents of this manual is prohibited.
The contents of this manual may change without notice.

INTRODUCTION

This Service Manual describes the Cool Laminator LX-200/900/910D specifications, operating principles of the mechanisms, disassembly and reassembly procedures, and maintenance and troubleshooting procedures.

This Service Manual is intended for use by trained technicians. It is not intended for use by the user.

The manual is divided into the following chapters.

- Chapter 1. Specifications
- Chapter 2. Mechanism
- Chapter 3. Disassembly Procedures
- Chapter 4. Reassembly Procedures
- Chapter 5. Electronic Controllers
- Chapter 6. Maintenance
- Chapter 7. Troubleshooting
- Appendix Main PCB Circuit Diagram

Chapter 1.
SPECIFICATIONS

CONTENTS

Chapter 1. SPECIFICATIONS

1.1	Mechanical Specifications.....	1-1
1.1.1	Appearance.....	1-1
1.1.2	Operating Panel.....	1-1
1.1.3	Indicators.....	1-2
1.2	Electrical Specifications.....	1-2
1.2.1	Power Supply.....	1-2

1.1 Mechanical Specifications

1.1.1 Appearance

- [1] External dimensions (W x D x H) 357 mm x 293 mm x 195 mm
- [2] Mass Approx. 4.6 kg (main unit only)

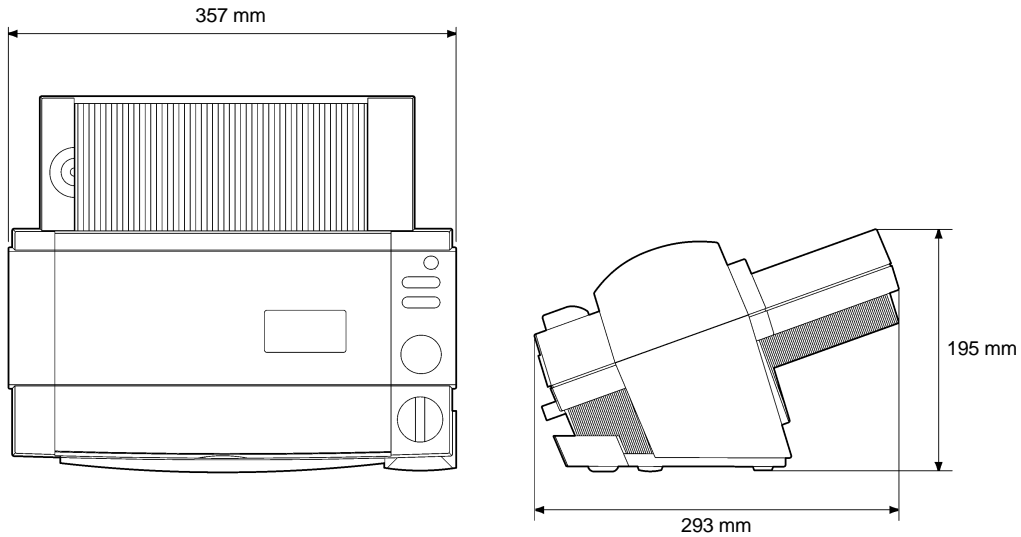

Fig. 1.1-1 Appearance

1.1.2 Operating Panel

- [1] Number of Keys 5 (Power switch, Cut key, Feed key, Start/Stop button, Cutting mode selector)
- [2] Key Arrangement

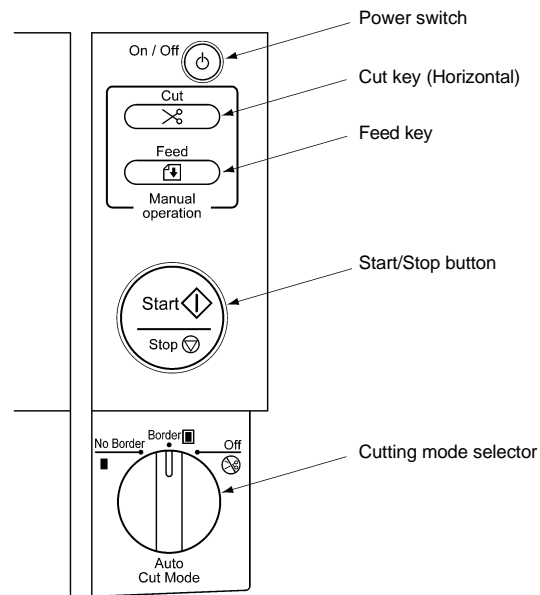

Fig. 1.1-2 Key Arrangement

1.1.3 Indicators

[1] Positions

Start/Stop button LED indicators (red, green, orange)

1.2 Electrical Specifications

1.2.1 Power Supply

[1] Power supply

Commercial power supply (locally available power supply).
Converted to DC by the AC adaptor.

Chapter 2.
MECHANISMS

CONTENTS

Chapter 2. MECHANISMS

2.1	Mechanical Operating Principles	2-1
2.1.1	Description of Mechanisms (Border Mode)	2-1
2.1.2	Feed and Compression Mechanisms	2-2
2.1.3	Cutter Mechanism (Border Mode)	2-4
2.1.4	Paper Size Detector Mechanism	2-6
2.1.5	Trimming Mechanism	2-8

2.1 Mechanical Operating Principles

2.1.1 Description of Mechanisms (Border Mode)

1. When a document is inserted into the paper loading gate, the paper feed rollers feed it to the driving roller.
2. As the document passes between the paper feed rollers, the paper size detector determines its size (length and width).
3. When the document passes between the film cartridges it is sandwiched between the upper and lower films in the compression-feed area, where the films and document are compressed between the driving roller and sub-roller.
4. The compressed document and film is fed to the cutting area, where it is cut to the document size detected by the paper size detector with borders added. It is then transported to the next stage.
5. The laminated document is fed out of the eject gate by the paper eject rollers.

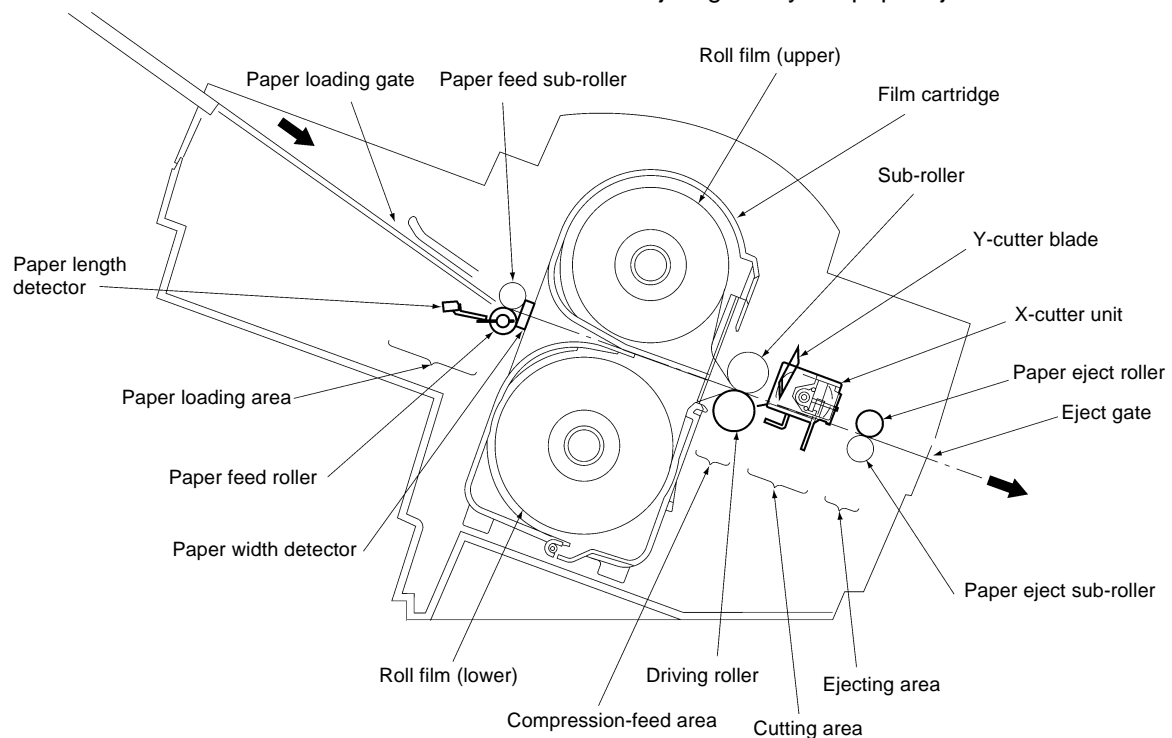

Fig. 2.1-1 Description of Mechanisms

2.1.2 Feed and Compression Mechanisms

The feed and compression mechanism controls the motor drive to feed the document into the film cartridge, compression-feed the films, and eject the laminated document.

When no compression-feed is applied while feeding a document into the film cartridge or ejecting a laminated document, the LF motor rotates clockwise and the motor drive is transmitted via gears to the paper feed roller and paper eject roller.

At this time, the planet gear (A) is free from the drive gear (A), such that the drive is not transmitted to the driving roller.

During compression-feeding of the films, LF motor rotates counterclockwise to move the planet gear (A) against the drive gear (A), such that the drive from the LF motor is transmitted to the driving roller.

Also, planet gear (B) moves against the drive gear (B) and planet gear (C) moves against the drive gear (C), such that the LF motor drive continues to be transmitted to the paper feed roller and paper eject roller, without changing the direction of roller rotation.

- Operation when Feeding Document into the Film Cartridge or when Ejecting a Laminated Document
 1. When the LF motor rotates clockwise (as indicated by the arrow in the diagram), the drive is transmitted via a series of gears to drive the paper feed roller and paper eject roller in the directions indicated by the arrows. At this time, planet gear (A) is free, such that no drive is transmitted to drive gear (A) and the driving roller does not rotate.
 2. The document is fed into the film cartridge when the paper feed roller rotates in the direction indicated by the arrow.
 3. The laminated document is ejected from the eject gate when the paper eject roller rotates in the direction indicated by the arrow.

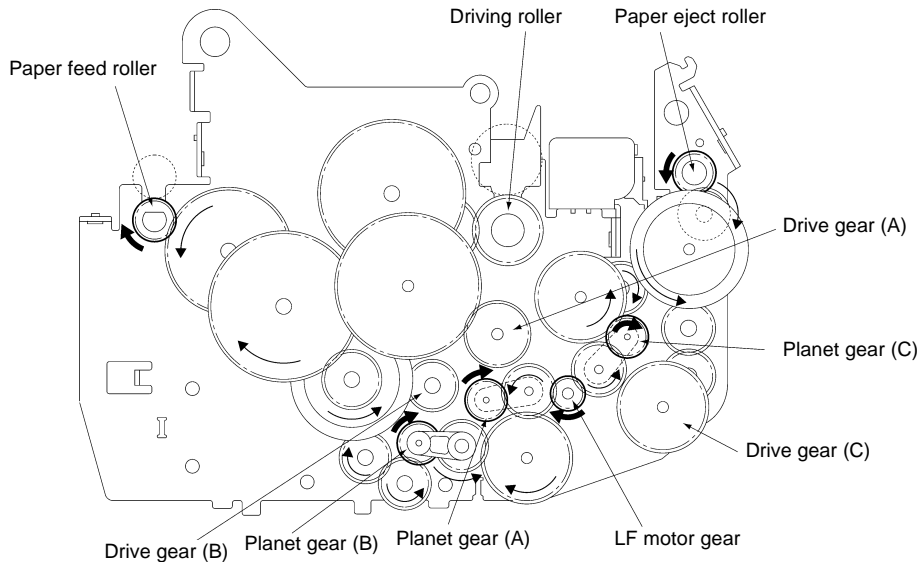

Fig. 2.1-2 Operation when Feeding Document into the Film Cartridge or when Ejecting a Laminated Document

- Operation During Film Compression-Feed
 1. When the leading edge of the document enters the compression-feed area, LF motor starts to rotate counterclockwise, as indicated by the arrow.
 2. Planet gear (A), which had been free, moves to engage with drive gear (A). The drive from the LF motor is then transmitted to the various gears, as shown in the diagram, and the driving roller rotates as indicated by the arrow. Also, planet gear (B) moves against the drive gear (B) and planet gear (C) moves against the drive gear (C), such that the LF motor drive continues to be transmitted to the paper feed roller and paper eject roller, without changing the direction of roller rotation.
 3. The rotation of the driving roller is transmitted to the sub-roller. These rollers feed the films and press them against the document. At this time, the rotations of the paper feed roller and paper eject roller continue uninterrupted.
 4. When the trailing edge of the document leaves the compression-feed area and the X-cutters finish cutting the film, the LF motor reverses to rotate counterclockwise. Planet gear (A) again becomes free such that the driving roller rotation stops and feeding of the films also stops.

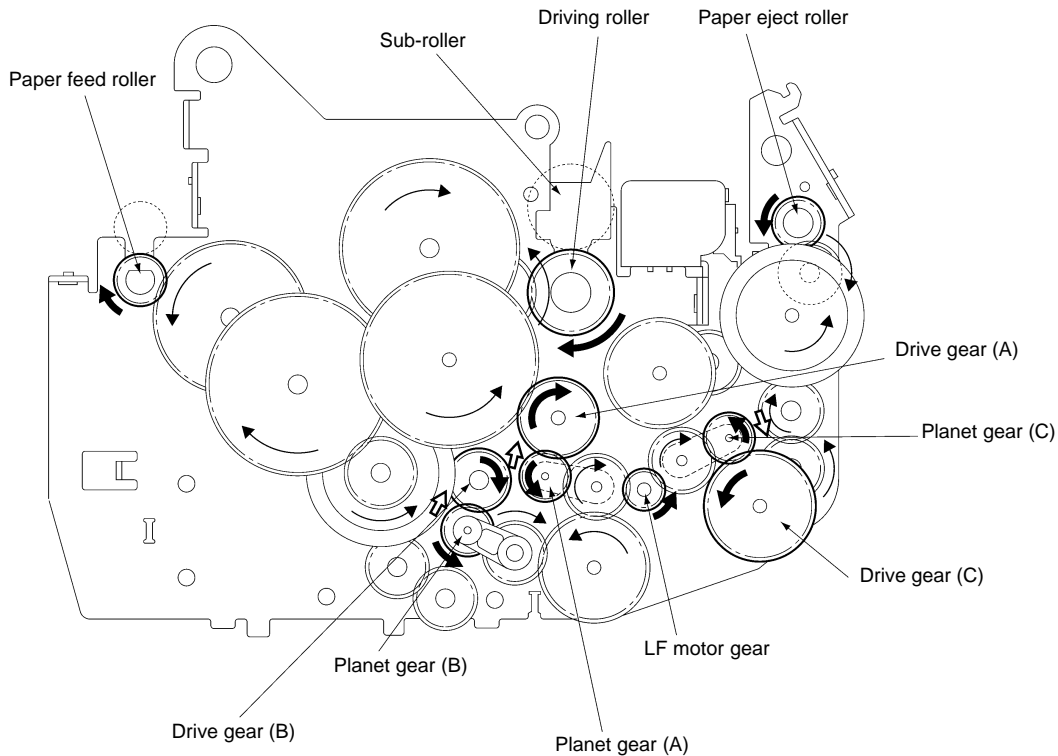

Fig. 2.1-3 Operation During Film Compression-Feed

2.1.3 Cutter Mechanism (Border Mode)

The cutter mechanism cuts the laminated document to the size of the document plus an added border. Both edges of the films are cut to suit the width of the document and the leading edge and trailing edge are cut according to the document length.

- Y-Cutter Vertical Drive Operation

1. The TC motor rotates clockwise from its reference position to drive the cam clockwise via a series of gears. The cam rotates the Y-diversion lever clockwise about its pivot. (All rotations indicated by arrows.)

When the Y-diversion lever reaches its maximum displacement position with the cam at approximately its 180° rotated position, rotation of the TC motor pauses.

2. When the Y-diversion lever reaches its maximum displacement position, its movement lowers the two Y-cutter blades from the standby position to the cutting position, where they start cutting the edges of the laminated film.
3. When the Y-axis cutters reach the trailing edge cutting position, the TC motor starts rotating again and stops when it reaches its reference position. This rotation returns the cam and Y-diversion lever to their original positions and the cutters move to their standby positions.

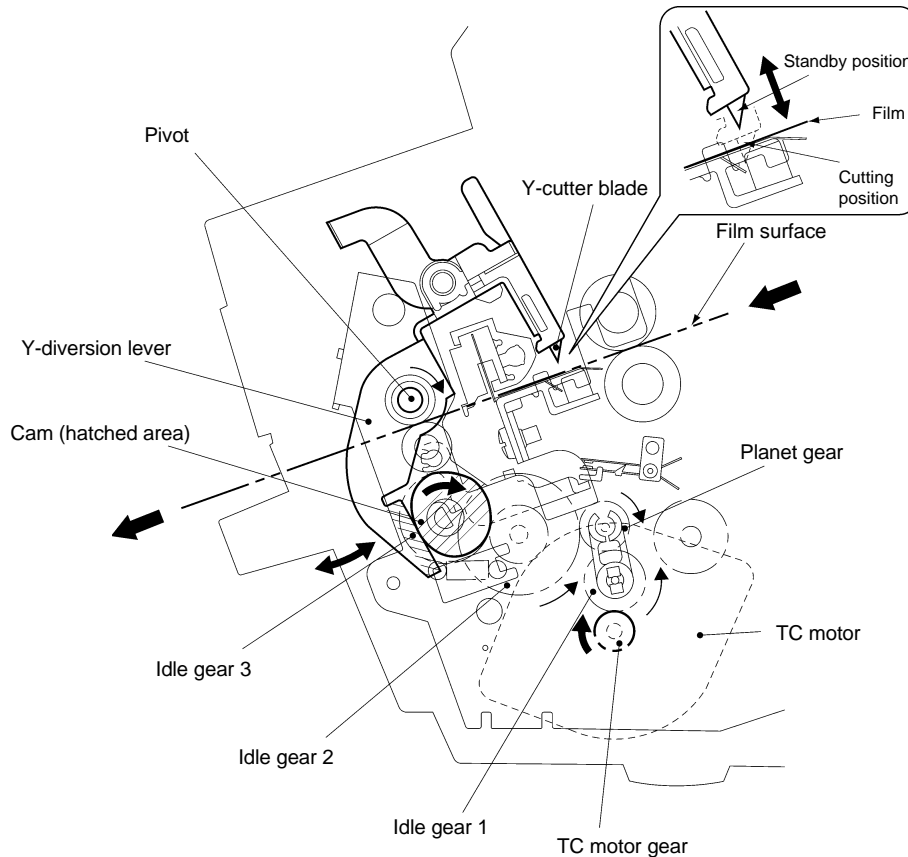

Fig. 2.1-4 Y-Cutter Vertical Drive Operation

- Cutting Leading and Trailing Edges (X-cutter Mechanism)
 1. All the rollers which feed the document stop when the cut position at the leading edge of the document reaches the cutting position of the rotary cutter and fixed-blade cutter.
 2. The DC motor rotates to drive the carriage in the X-cutter assembly via the spiral mechanism (not illustrated).
 3. As the carriage makes a reciprocal movement, the rotary cutter attached to the carriage moves against the fixed cutter to cut the compressed leading edge of the document.
 4. The rotation of the rollers which feed the document restarts when the cutting of the leading edge is complete. Then, when the cut position at the trailing edge of the document reaches the cutting position of the rotary cutter and fixed-blade cutter, the feed rollers stop again.
 5. The document trailing edge is cut in the same way as the leading edge, by a reciprocal movement of the rotary cutter attached to the carriage.
 6. The rotation of the rollers restarts to feed the laminated document from the eject gate after the cutting of the trailing edge is complete.

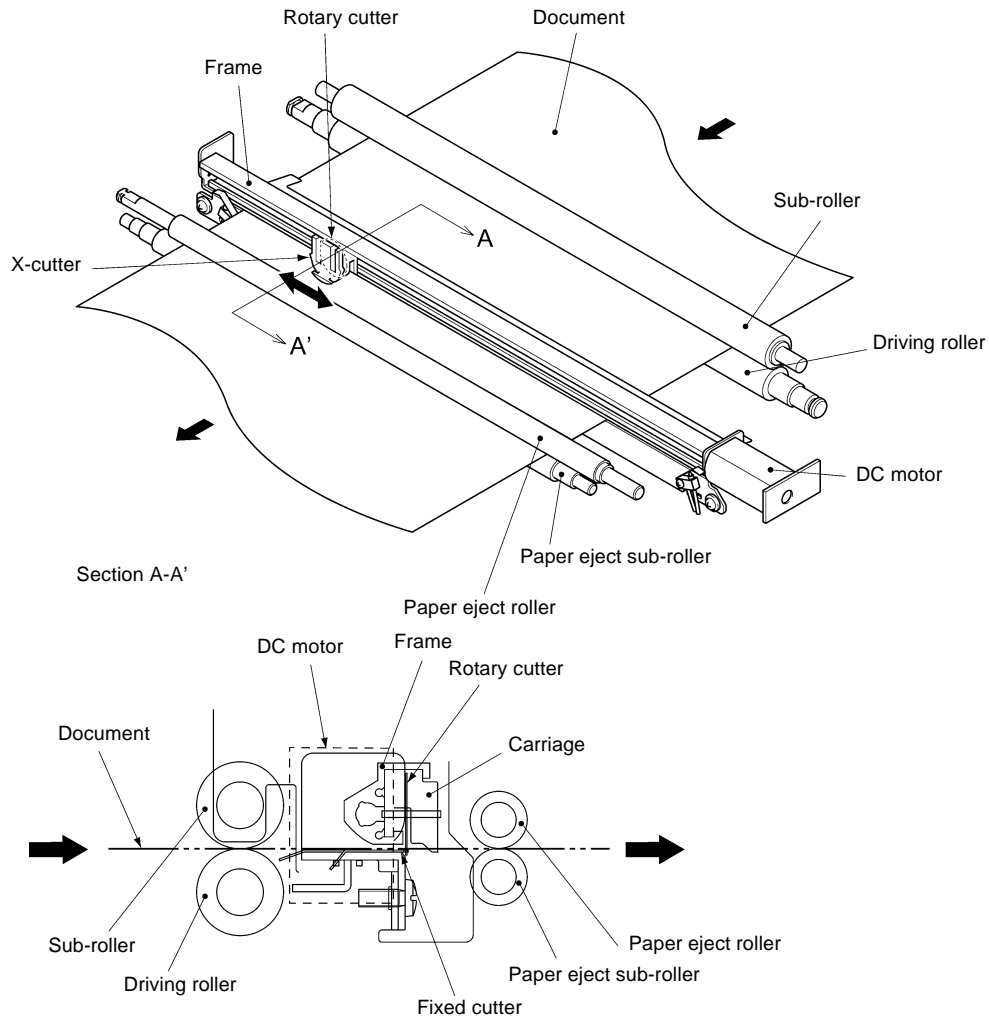

Fig. 2.1-5 Cutting Leading and Trailing Edges (X-cutter Mechanism)

2.1.4 Paper Size Detector Mechanism

- Paper Length Detection

1. When the leading edge of the document passes between the paper feed rollers, it rotates the paper sensor crank about the pivot to turn on the paper sensor which detects the document leading edge.
2. When the trailing edge of the document passes out of the paper feed rollers, the paper sensor crank reverts to its original position to turn off the paper sensor to detect the document trailing edge.

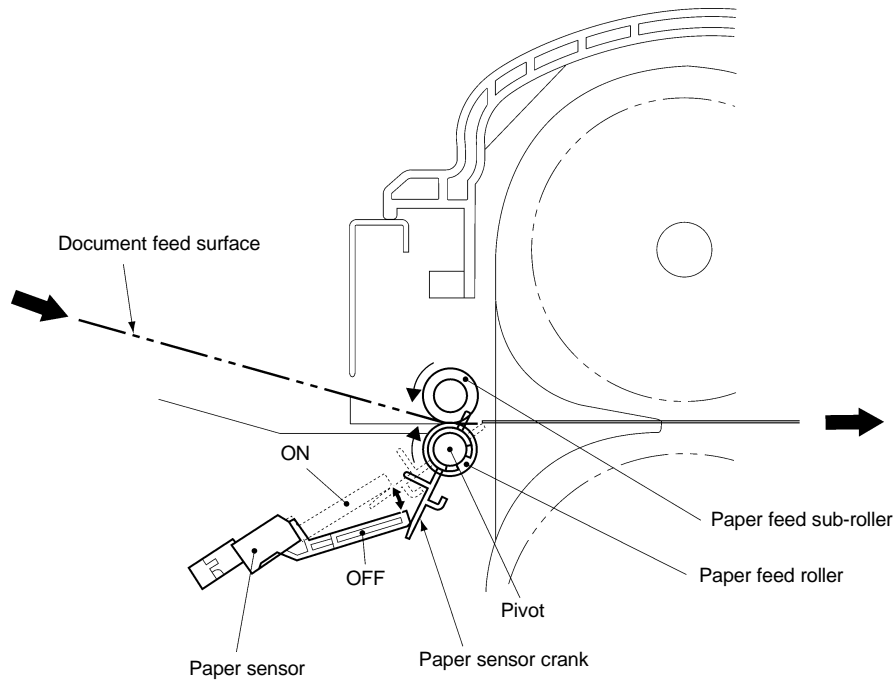
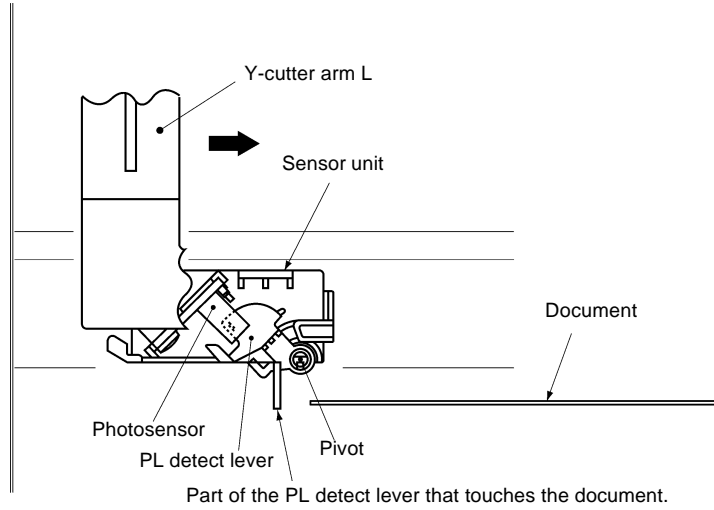

Fig. 2.1-6 Paper Length Detection

- Paper Width Detection

1. The Y-cutter arm L (sensor unit) moves in the direction of the arrow. When the PL detect lever touches the document, it rotates about the pivot to switch off the photosensor.
2. When the photosensor turns off, the Y-cutter arm L movement stops and this position is detected as the document width.



* Photosensor ON status

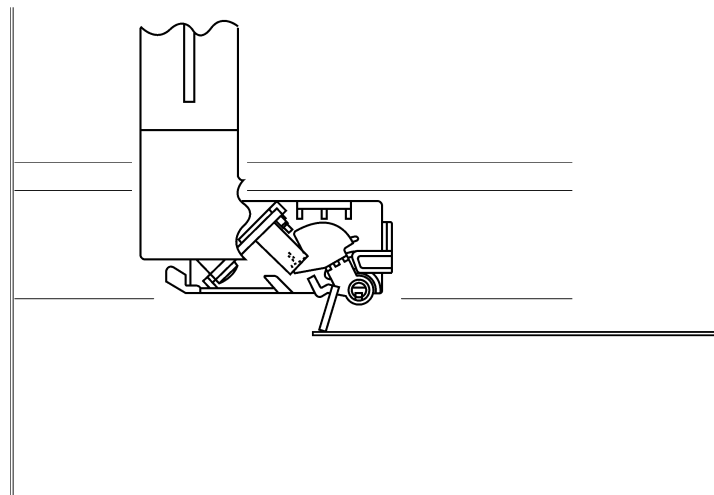

* Photosensor OFF status

Fig. 2.1-7 Paper Width Detection

2.1.5 Trimming Mechanism

1. When a corner of the laminated document is inserted over the T-cutter plate, the sensor lever operates a leaf switch that detects the document.
2. When the document is detected, the motor gear of TC motor rotates in the direction of the arrow (counterclockwise) from its reference position to drive the T-cam gear in the direction indicated by the arrow (clockwise) via a series of gears.
3. Rotation of the T-cam gear forces the T-cam roller to make a vertical movement, such that T-lever1 moves vertically, rotating around its pivot.
4. As T-lever 1 moves vertically, the T-cutter mounted on the end of T-lever 1 moves up and down, trimming the corner of the laminated document into a rounded radius.

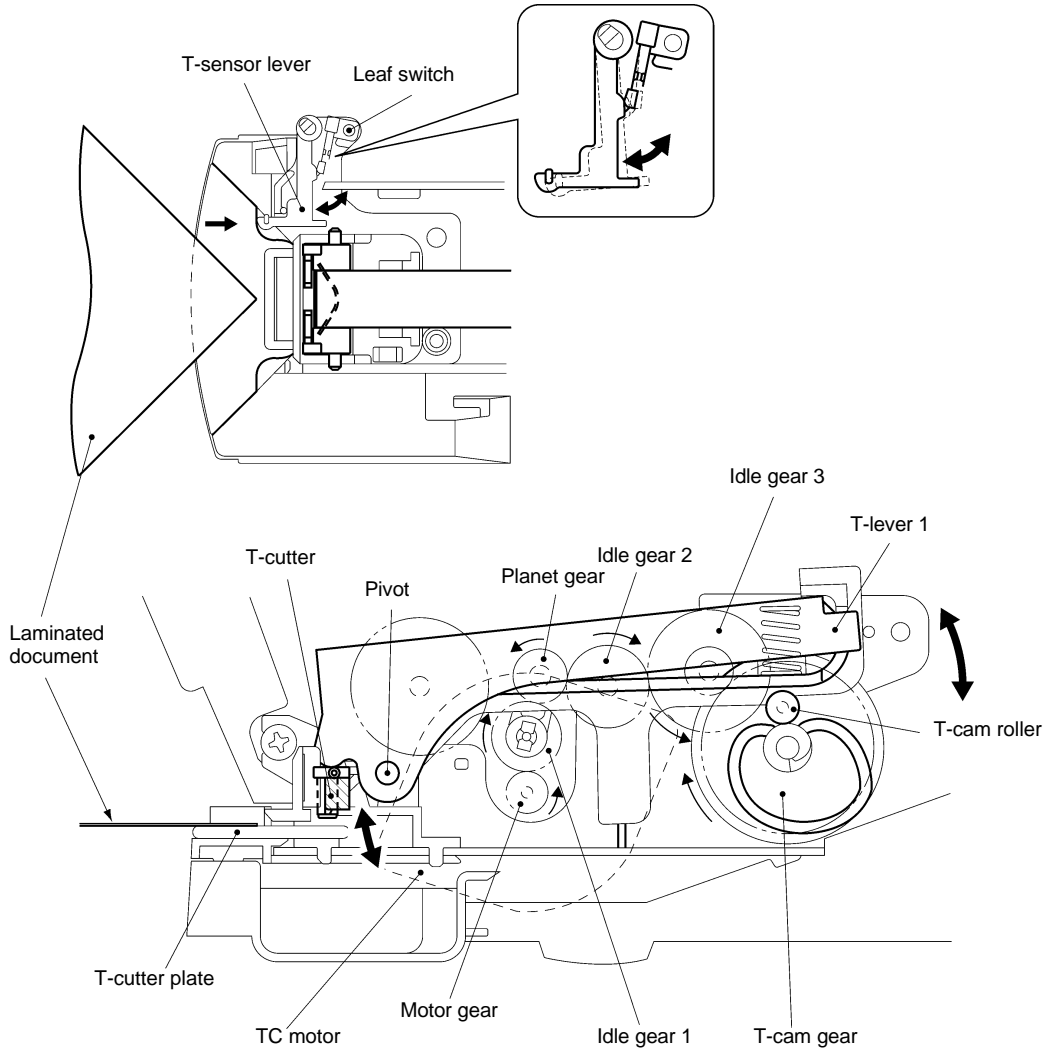

Fig. 2.1-8 Trimming Mechanism

Chapter 3.

DISASSEMBLY PROCEDURES

CONTENTS

Chapter 3. DISASSEMBLY PROCEDURES

3.1	Safety Precautions	3-1
3.2	Removing the Film Cartridge	3-1
3.3	Covers	3-2
3.3.1	Removing the Trimmer Upper Cover	3-2
3.3.2	Removing the Top Cover	3-3
3.3.3	Removing the Sub-tray	3-4
3.3.4	Removing the Paper Tray and Paper Guide.....	3-4
3.3.5	Removing the Body Cover B.....	3-5
3.3.6	Removing the Front Cover.....	3-7
3.3.7	Removing the Cover Switch Assy	3-8
3.3.8	Removing the Dial Switch Holder Assy B.....	3-9
3.3.9	Disassembling the Dial Switch Holder Assy B	3-10
3.4	Chassis.....	3-12
3.4.1	Removing the Harness Connectors.....	3-12
3.4.2	Removing the PE Sensor Unit	3-12
3.4.3	Removing the Chassis Unit	3-13
3.5	PCBs.....	3-15
3.5.1	Removing the Main PCB Assy.....	3-15
3.5.2	Removing the Jack PCB Assy	3-15
3.5.3	Removing the Switch PCB Assy.....	3-16
3.6	T-Chassis	3-17
3.6.1	Removing the T-Chassis Unit.....	3-17
3.6.2	Disassembling the T-Chassis Unit.....	3-18
3.7	Y-CA Chassis	3-19
3.7.1	Removing the Y-CA Chassis Assy	3-19
3.7.2	Disassembling the Y-CA Chassis Assy	3-20
3.7.3	Removing the Roller Holder Assy.....	3-21
3.7.4	Disassembling the Roller Holder Assy	3-22
3.8	Sensor Frame and Y-cutter Arm L	3-23
3.8.1	Removing the Sensor Frame.....	3-23
3.8.2	Removing the Y-cutter Arm L	3-23
3.8.3	Disassembling the Sensor Frame	3-24
3.8.4	Disassembling the Y-cutter Arm L.....	3-25
3.9	Paper Feed Roller	3-26
3.9.1	Removing the Paper Feed Sub-roller Assy	3-26
3.9.2	Removing the Paper Feed Roller Assy.....	3-27

3.10 Paper Eject Roller	3-28
3.10.1 Removing the Y-D Shaft	3-28
3.10.2 Removing the Paper Eject Sub-roller Unit.....	3-29
3.10.3 Removing the Paper Eject Roller Unit	3-29
3.11 Y-diversion Lever	3-30
3.11.1 Removing the Y-diversion Lever Assy.....	3-30
3.11.2 Disassembling the Y-diversion Lever Assy	3-31
3.12 X-cutter	3-32
3.12.1 Removing the X-cutter Unit.....	3-32
3.12.2 Disassembling the Tape Sensor Unit	3-32
3.13 Driving Roller.....	3-33
3.13.1 Removing the Driving Roller.....	3-33
3.14 Left Side of the Chassis	3-33
3.14.1 Removing the Gears	3-33
3.14.2 Disassembling the Left Side of the Chassis	3-35
3.15 Right Side of the Chassis	3-36
3.15.1 Disassembling the Right Side of the Chassis.....	3-36
3.16 Lower Chassis.....	3-37
3.16.1 Removing the Left and Right Sides of the Chassis	3-37
3.16.2 Removing the Cassette Holder	3-38
3.16.3 Removing the Encoder (ENC) Sensor PCB	3-38
3.16.4 Removing the Cassette Detect Switch	3-39

3.1 Safety Precautions

When conducting disassembly operations, place the unit on a grounded anti-static sheet. LSI and other electronic components are sensitive to static electricity and may be damaged if touched while charged.

Before transporting a circuit board, wrap it in a conducting sheet such as aluminum foil.

When using a soldering iron or other heat-producing tool, ensure that heat does not damage wires, circuit boards, or plastic parts such as covers.

Take care not to lose small screws or washers removed when replacing parts.

3.2 Removing the Film Cartridge

1. Open the top cover and move the Y-cutter arm L as far as possible to the left.
2. Push the lock lever R in the direction indicated by the arrow to unlock the roller holder assy.

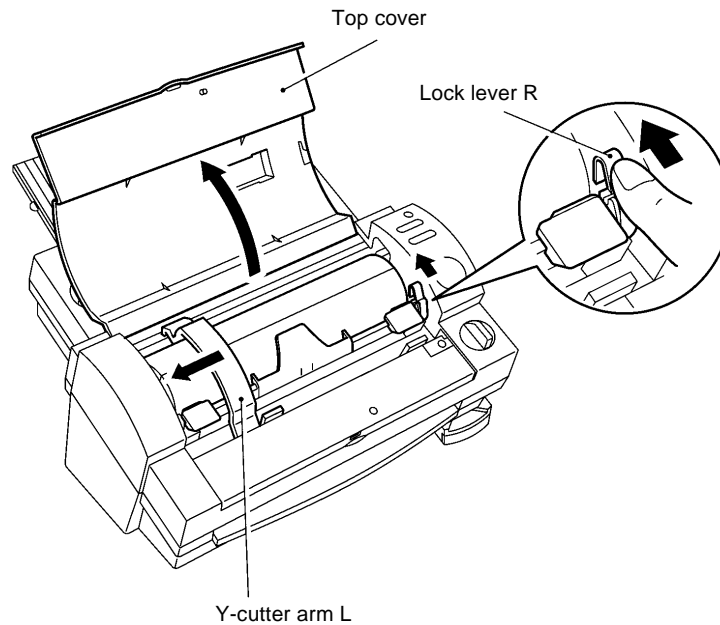

Fig. 3.2-1 Removing the Film Cartridge 1

3. Lift up the roller holder assy and pull out the film cartridge.

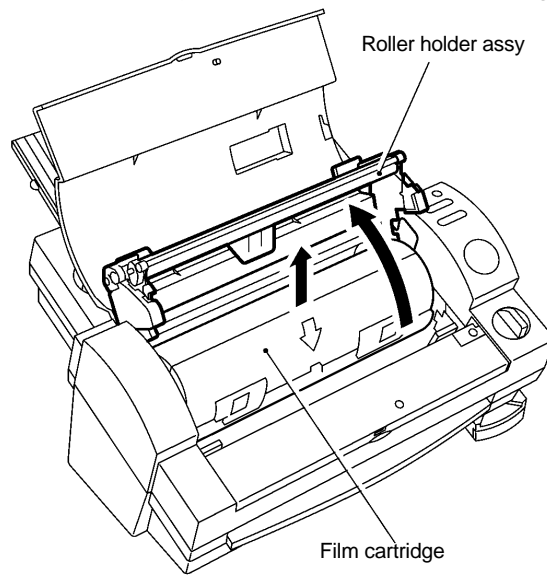

Fig. 3.2-2 Removing the Film Cartridge 2

3.3 Covers

3.3.1 Removing the Trimmer Upper Cover

1. Pull out the T-cutter plate and the trimmer bottom cover.

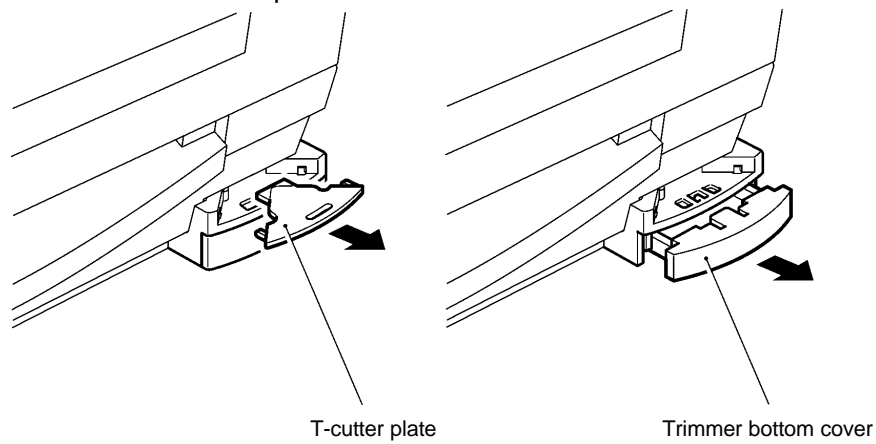

Fig. 3.3-1 Removing the Trimmer Cover 1

2. Set the unit on its side with the trimmer cover uppermost. Remove the two trimmer cover screws. Remove the trimmer upper cover.

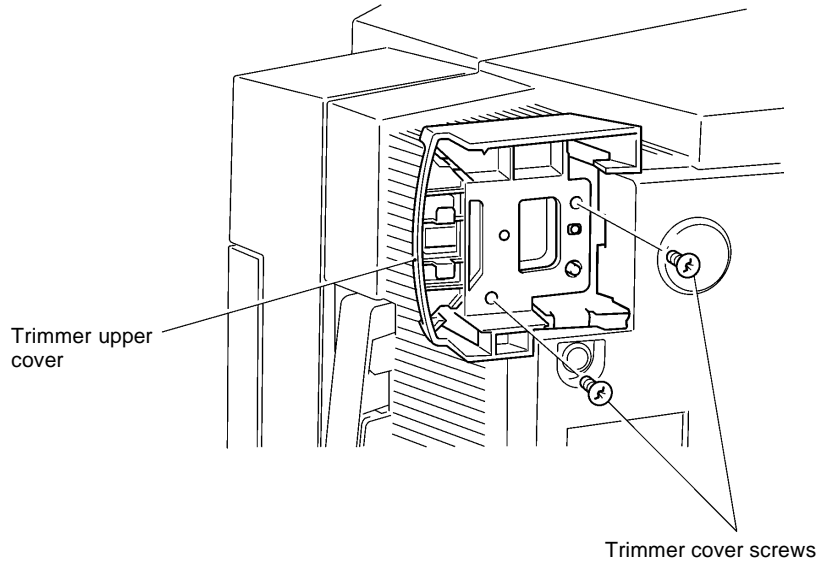

Fig. 3.3-2 Removing the Trimmer Upper Cover 2

3.3.2 Removing the Top Cover

Open the top cover. Lift the top cover shafts out of the shaft recesses in the body cover and remove the cover.

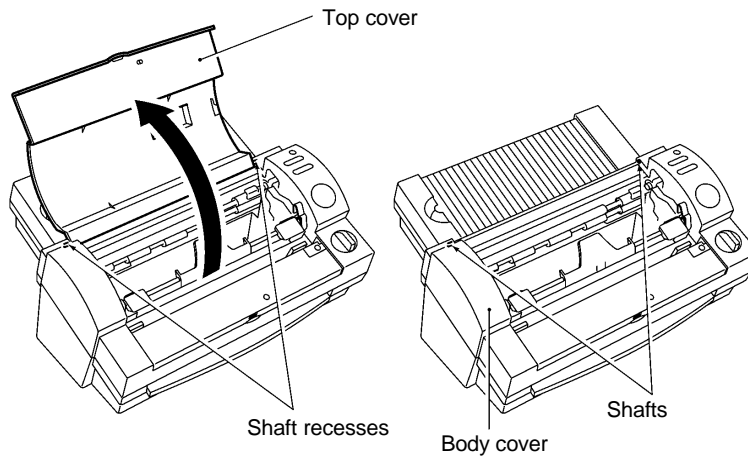

Fig. 3.3-3 Removing the Top Cover

3.3.3 Removing the Sub-tray

1. Open the sub-tray.
2. Flex the center of the sub-tray toward you to release the shafts from the shaft recesses in the body cover. Remove the sub-tray.

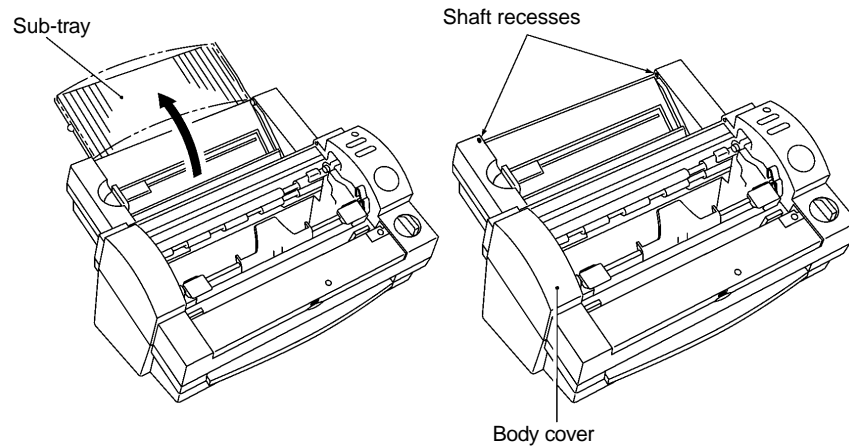

Fig. 3.3-4 Removing the Sub-tray

3.3.4 Removing the Paper Tray and Paper Guide

1. Lift the top of the paper tray in the direction of arrow A, then pull it in the direction of arrow B. Remove the paper tray.

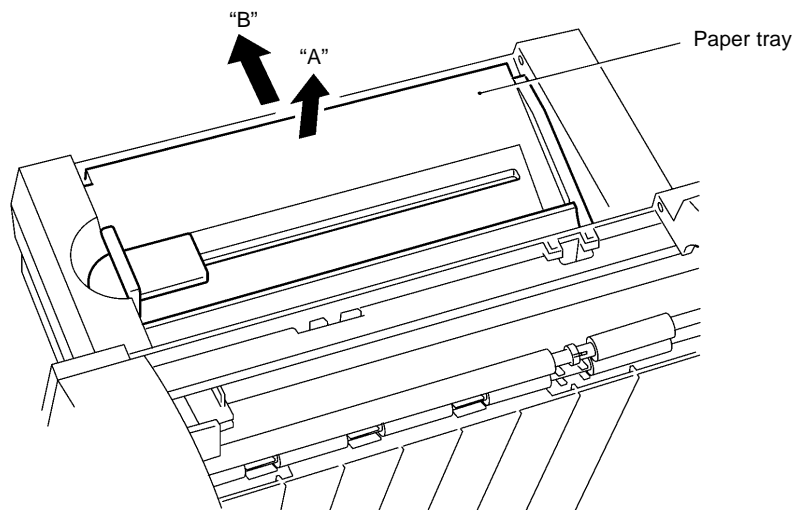

Fig. 3.3-5 Removing the Paper Tray

2. Disengage the paper guide hook (at the rear of the paper tray) from the paper tray. Remove the paper guide.

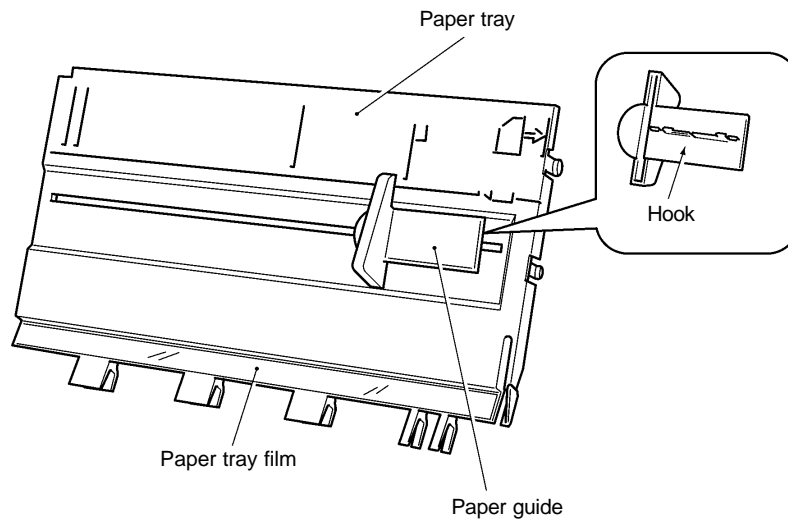

Fig. 3.3-6 Removing the Paper Guide

3.3.5 Removing the Body Cover B

1. Remove the two bottom cover screws A from the bottom of the bottom cover.

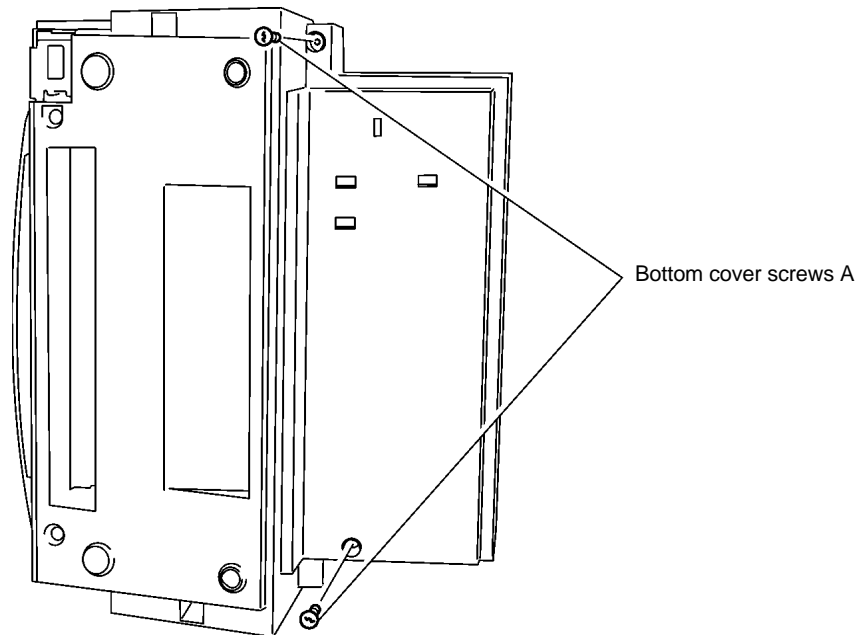

Fig. 3.3-7 Removing the Body Cover B (1)

2. Lift the rear of the bottom cover in the direction of arrow B while pushing it in the direction of arrow A. Release the four hooks at the rear face.
3. Push the body cover in the directions indicated by the arrows C to release the hook at the left and right side.
4. Release the two hooks from the front of the body cover.

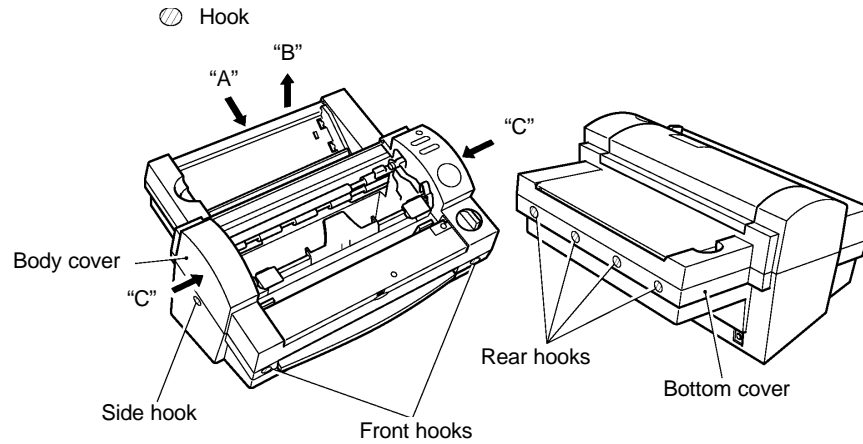

Fig. 3.3-8 Removing the Body Cover (2)

5. Disconnect the switch harness assy (white CN1) from the main PCB and remove the body cover. (The body cover switch PCB is connected to the main PCB of bottom cover via the switch harness assy.)

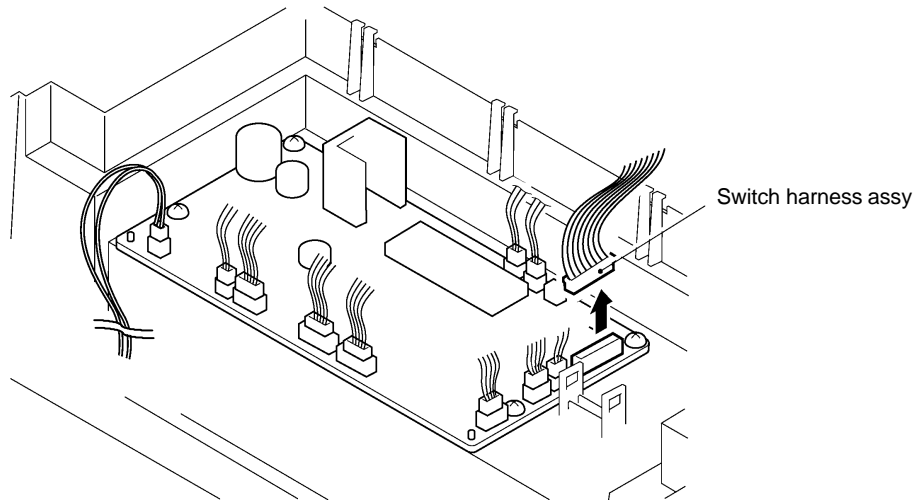

Fig. 3.3-9 Removing the Body Cover (3)

3.3.6 Removing the Front Cover

1. Remove the two front cover screws under the bottom cover.

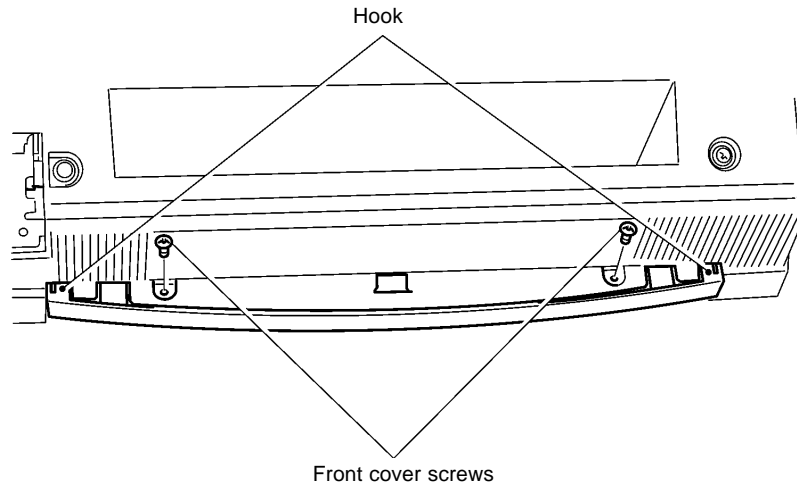

Fig. 3.3-10 Removing the Front Cover (1)

2. While pressing up the two hooks on the front cover from underneath, pull the front cover out to remove it.

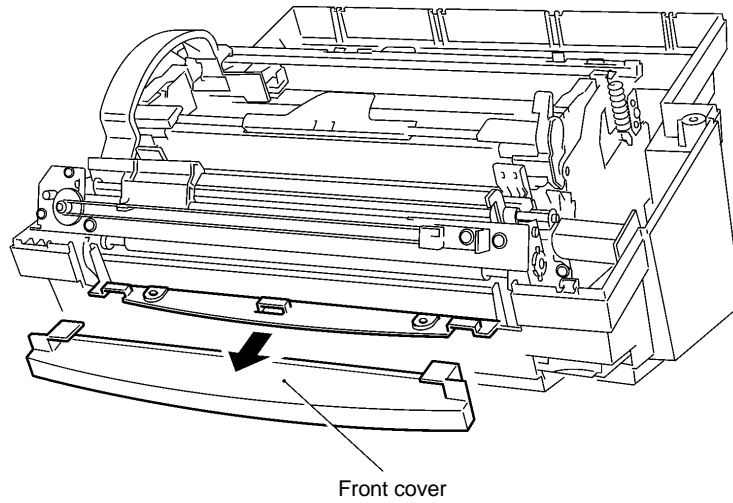

Fig. 3.3-11 Removing the Front Cover (2)

3.3.7 Removing the Cover Switch Assy

1. Disconnect the cover switch assy harness connector (yellow CN4) located under the body cover from the switch PCB.
2. Remove the cover switch screw. Remove the cover switch assy.

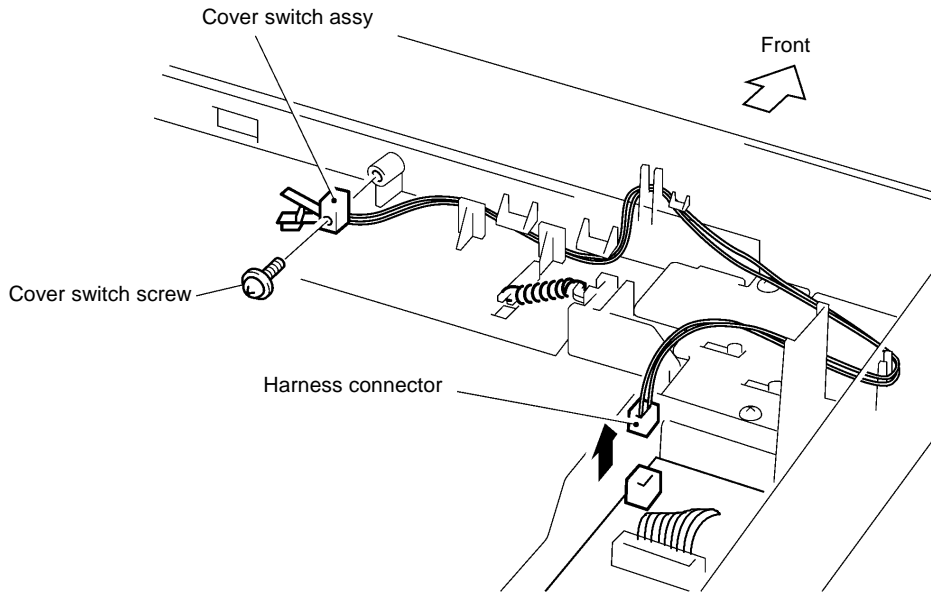

Fig. 3.3-12 Removing the Cover Switch Assy

3.3.8 Removing the Dial Switch Holder Assy B

1. Disconnect the leaf switch R Assy (red CN2) and leaf switch L Assy (white CN3) harness connectors from the switch PCB.
2. Remove the dial lock arm and the dial lock arm spring that is hooked on the body cover.
3. Remove the switch harness Assy from switch PCB.
4. Remove the two dial holder screws. Remove the Dial Switch Holder Assy B.

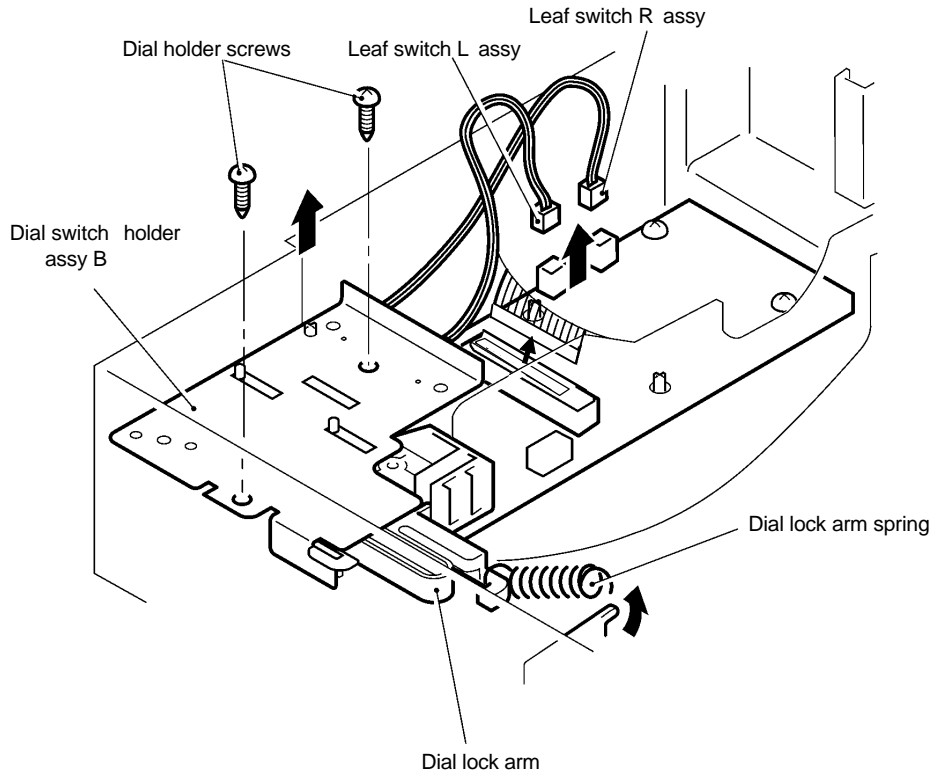

Fig. 3.3-13 Removing the Dial Switch Holder Assy B

3.3.9 Disassembling the Dial Switch Holder Assy B

1. Pull the plate spring in the direction of the arrow. Remove dial switch B.
2. Remove the two leaf switch R/L screws. Remove the leaf switch R Assy (red CN2) and the leaf switch L Assy (white CN3).

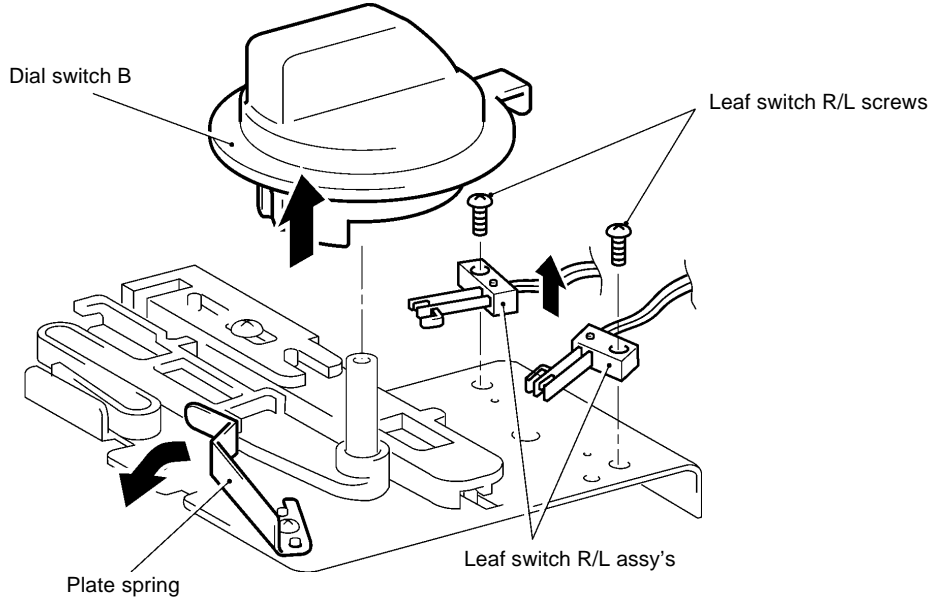

Fig. 3.3-14 Disassembling the Dial Switch Holder Assy B (1)

3. Remove the slide plate spring screw. Remove the plate spring.
4. Lift the slide plate 1B diagonally upward. Disengage slide plate 1B from the hook and remove it.

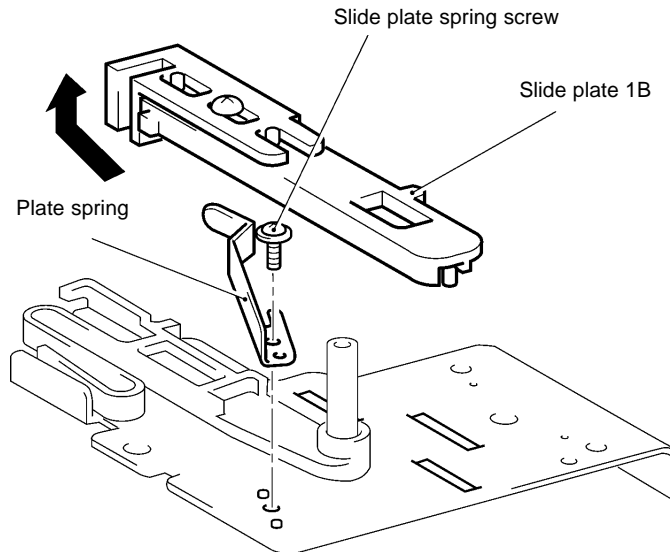

Fig. 3.3-15 Disassembling the Dial Switch Holder Assy B (2)

5.Remove the slide plate screw. Remove slide plate 2 from slide plate 1B.

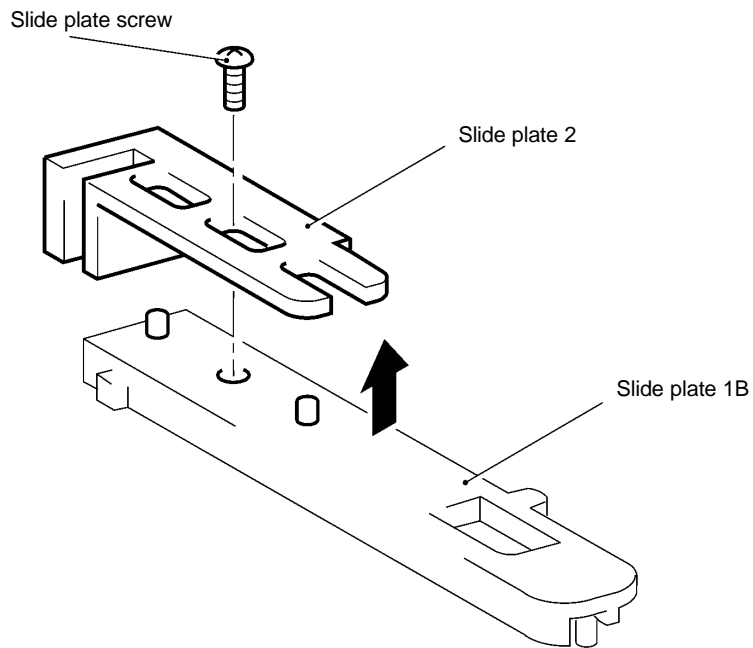

Fig. 3.3-16 Disassembling the Dial Switch Holder Assy B (3)

6.Disconnect lug A on the dial lock arm from the dial switch holder. Pull the dial lock arm off the shaft.

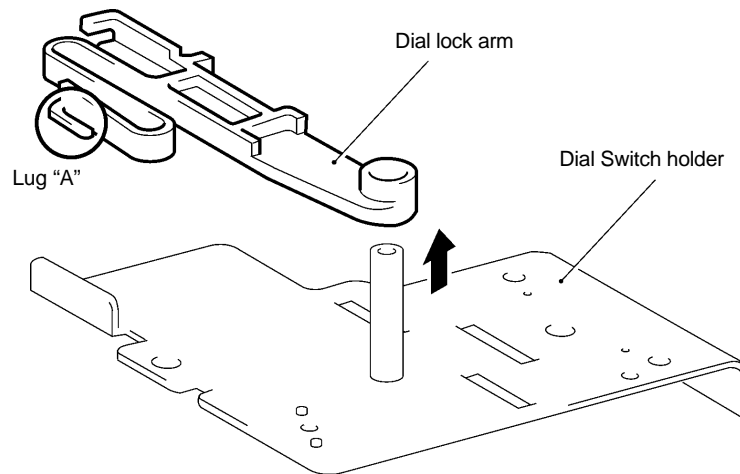

Fig. 3.3-17 Disassembling the Dial Switch Holder Assy B (4)

3.4 Chassis

3.4.1 Removing the Harness Connectors

Remove 12 harness connectors from the main PCB. Do not remove the power harness assy (red/black CN13).

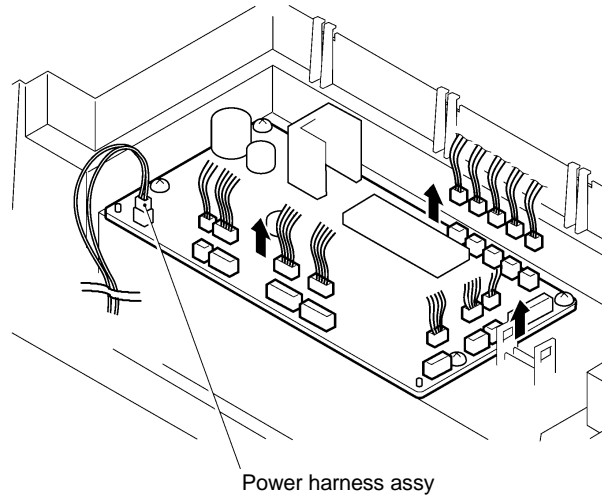

Fig. 3.4-1 Removing the Harness Connectors

3.4.2 Removing the PE Sensor Unit

Open the bearing supports in the bottom cover outward. Lift the PE sensor unit out of the bottom cover bearing supports. Pull the tip of the PE sensor unit off the paper feed roller shaft and remove the PE sensor unit. Take care not to damage the tip of the PE sensor unit when disconnecting it.

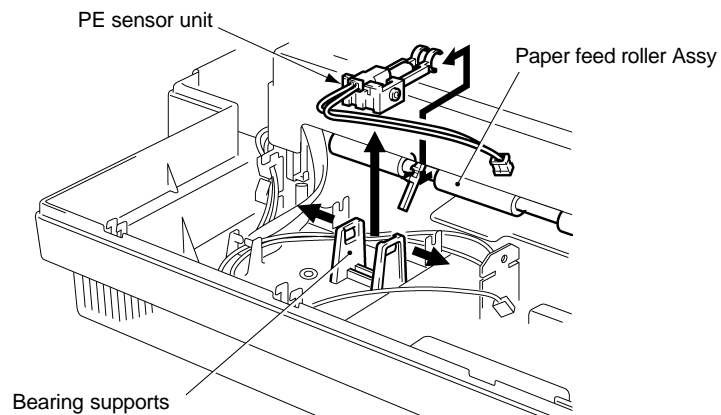

Fig. 3.4-2 Removing the PE Sensor Unit

3.4.3 Removing the Chassis Unit

1. Remove the sensor frame screw from the sensor frame. Remove the ground wire (jack PCB). After removing the wire, reinsert the sensor frame screw to fasten the sensor frame to the chassis.

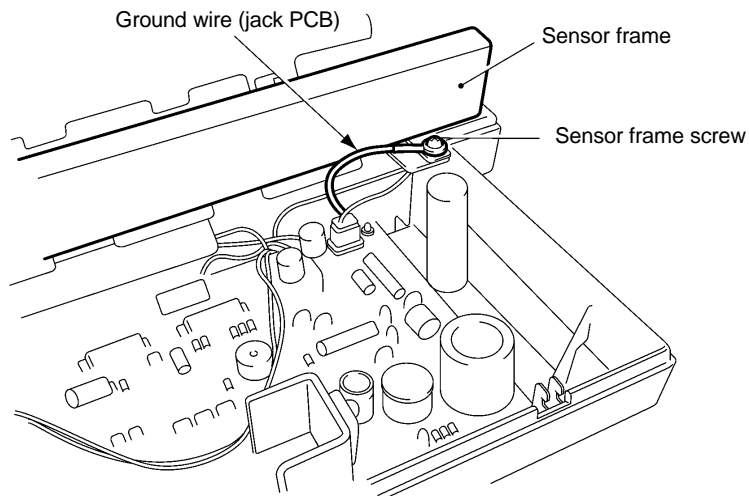

Fig. 3.4-3 Removing the Chassis Unit (1)

2. Remove the two bottom cover screws B and the spring washers from under the bottom cover B.

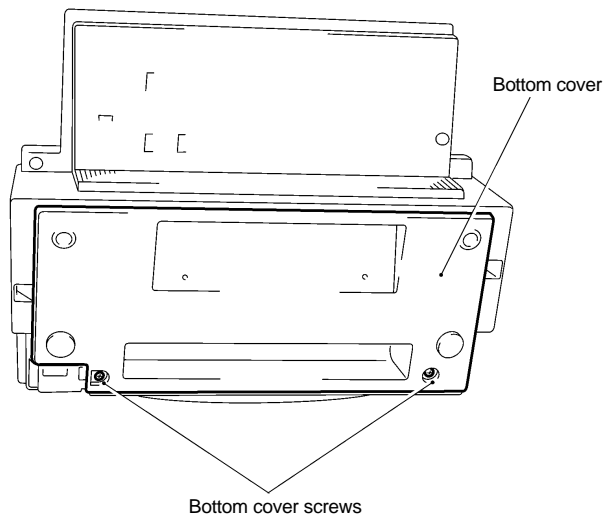

Fig. 3.4-4 Removing the Chassis Unit (2)

3.Remove the cassette holder screws from under the chassis unit.

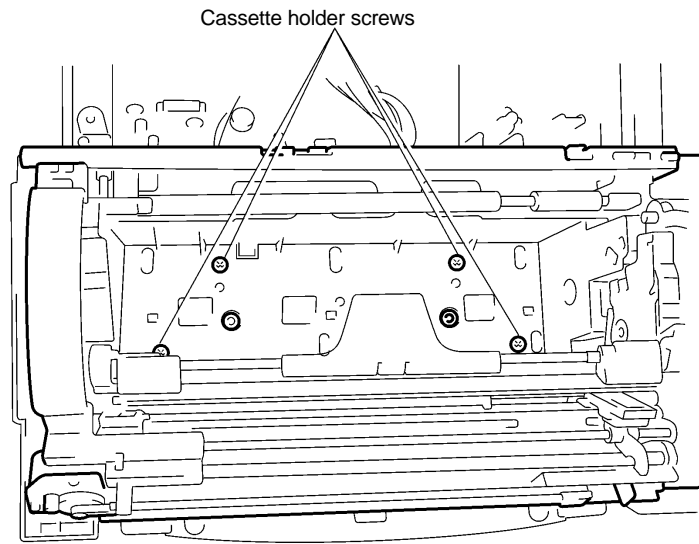

Fig. 3.4-5 Removing the Chassis Unit (3)

4.Pull out the chassis unit.

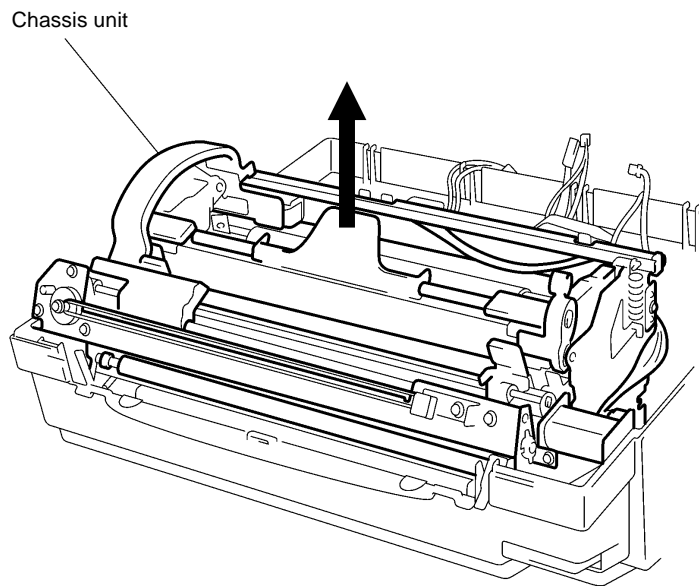

Fig. 3.4-6 Removing the Chassis Unit (4)

3.5 PCBs

3.5.1 Removing the Main PCB Assy

1. Disconnect the power harness assy (red/black CN13) from the Main PCB assy 1.
2. Remove the four main PCB screws. Remove the Main PCB assy 1.

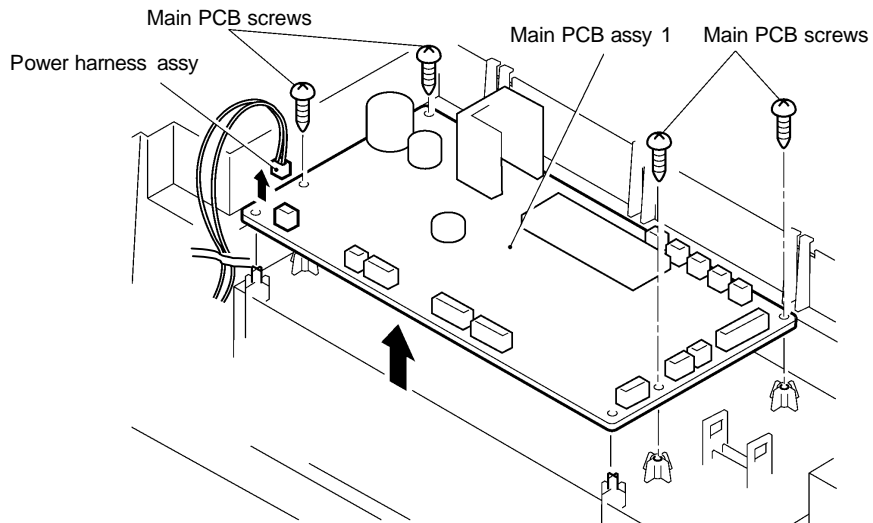

Fig. 3.5-1 Removing the Main PCB Assy

3.5.2 Removing the Jack PCB Assy

1. Remove the Jack PCB screw and remove the jack PCB assy 1.

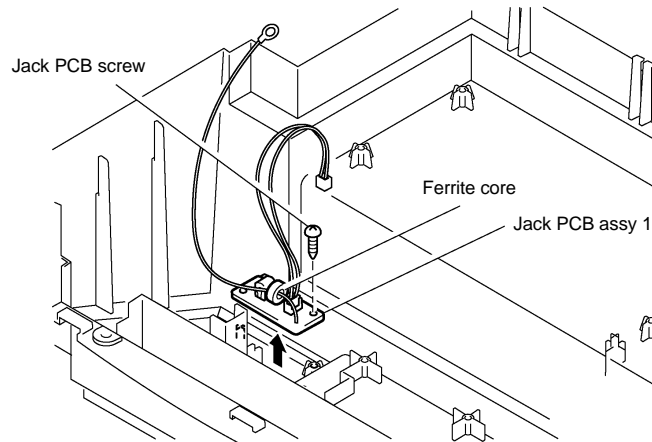

Fig. 3.5-2 Removing the Jack PCB Assy

3.5.3 Removing the Switch PCB Assy

1. Remove the two switch PCB screws A and three switch PCB screws B from under the body cover B. Remove the switch PCB assy 1.

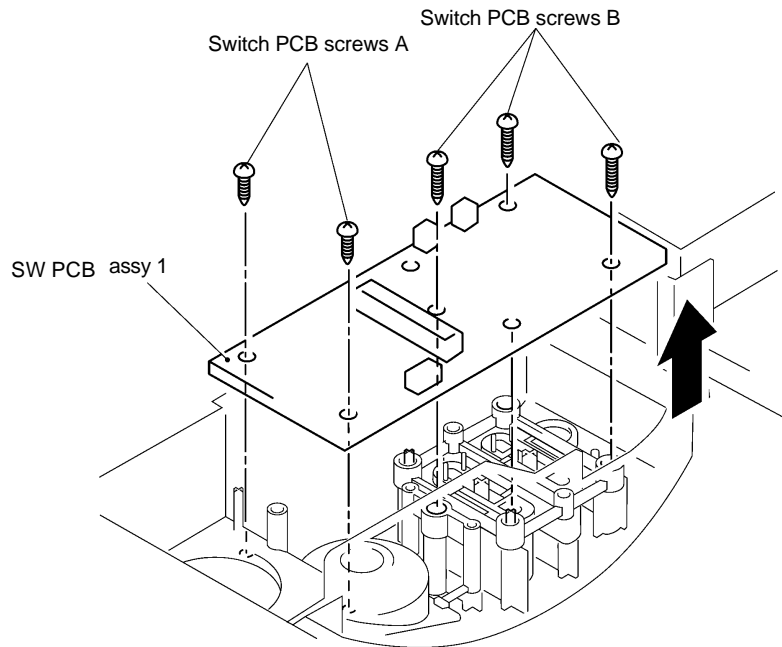

Fig. 3.5-3 Removing the Switch PCB Assy (1)

2. Remove the start switch B, start key film, start key actuator, two-connection switch, and power switch.

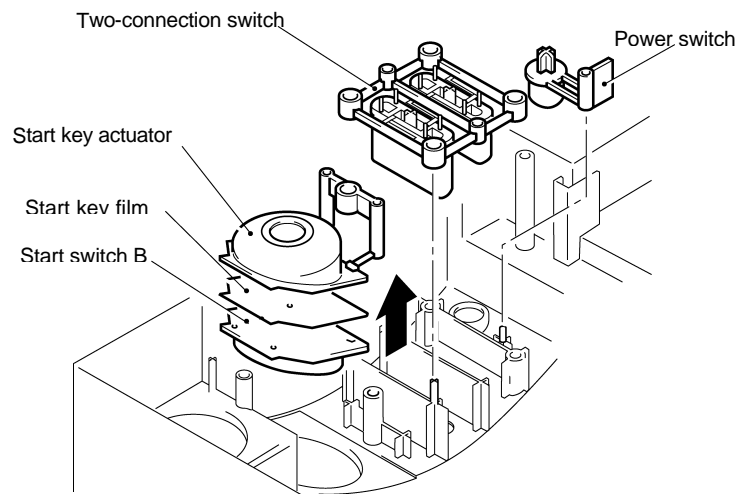

Fig. 3.5-4 Removing the Switch PCB Assy (2)

3.6 T-Chassis

3.6.1 Removing the T-Chassis Unit

- 1.Remove the plate spring screw. Remove the plate spring.
- 2.Remove the two T-chassis screws and remove the T-chassis unit.

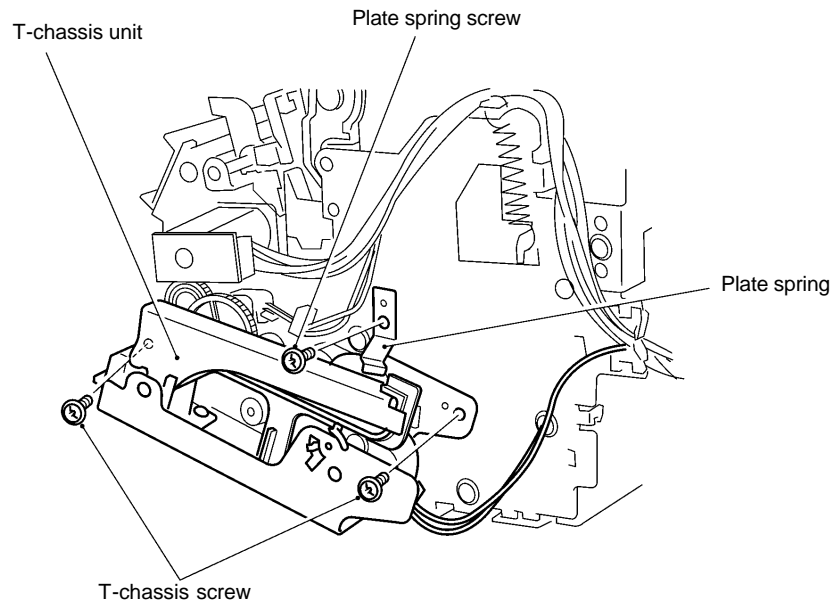

Fig. 3.6-1 Removing the T-Chassis Unit

3.6.2 Disassembling the T-Chassis Unit

1. Open hook A on the T-paper guide in the direction A'. Pull out the T-lever shaft to remove the T-lever unit.
2. Remove T-lever 2 from T-lever 1. Remove the T-push spring and T-cam roller.
3. Remove the leaf switch TRI screw and remove the leaf switch TRI assy.
4. Disconnect the switch lever from the shaft hook on the T-paper guide and remove the switch lever.
5. Remove the T-cutter upper unit from the T-paper guide. Remove the T-cutter stopper from the T-cutter holder, then remove the T-cutter.
6. Remove the paper guide screw and remove the T-paper guide.
7. Remove the leaf switch TRG screw and remove the leaf switch TRG assy.
8. Turn the T-sensor lever until lug A aligns with the slot in the T-chassis and remove the T-sensor lever.
9. Disengage hook B on the T-cam gear. Pull out the T-cam shaft to release T-gear 35-14 and T-idle gear.

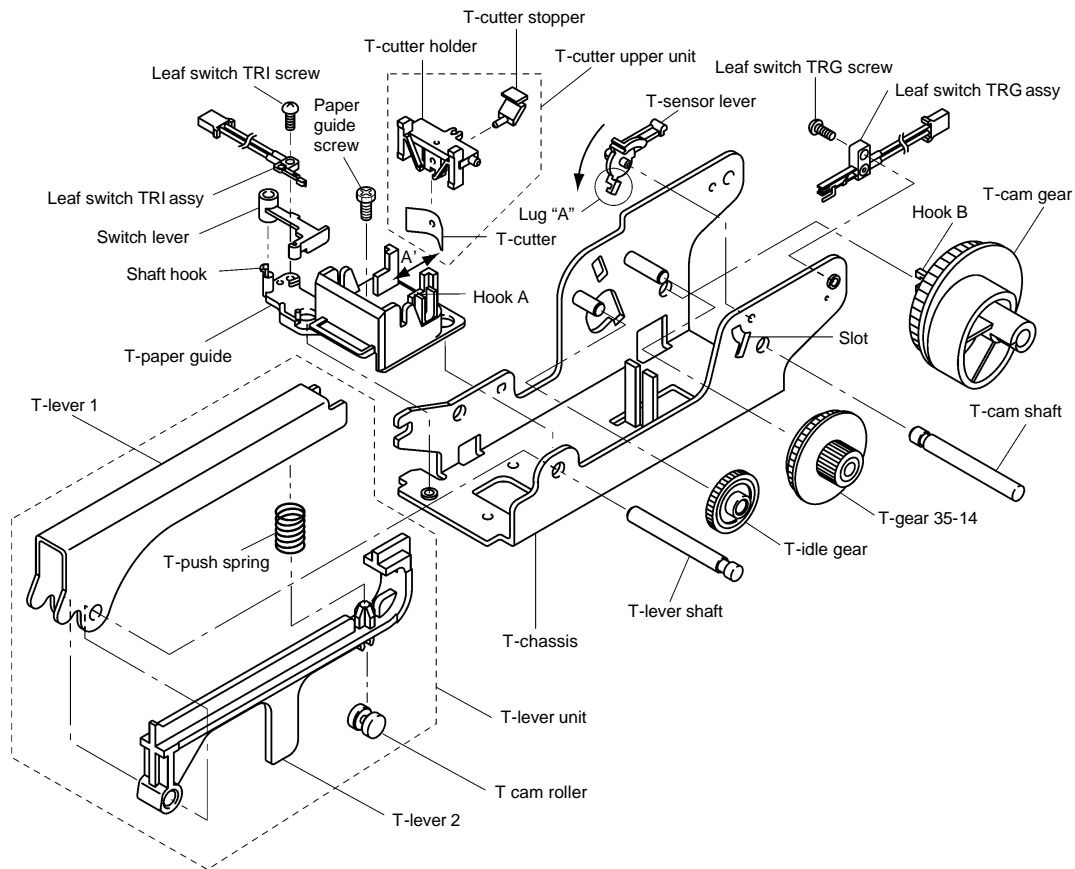

Fig. 3.6-2 Disassembling the T-Chassis Unit

3.7 Y-CA Chassis

3.7.1 Removing the Y-CA Chassis Assy

1. Remove the Y-extension spring L.
2. Remove the two Y-CA chassis screws
3. Remove the Y-CA timing belt from the Y-cutter arm and remove the Y-CA chassis assy.

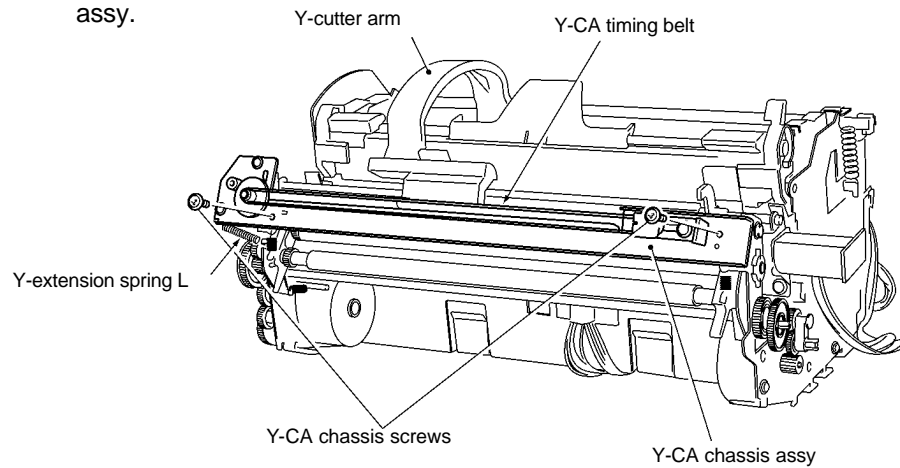

Fig. 3.7-1 Removing the Y-CA Chassis Assy

3.7.2 Disassembling the Y-CA Chassis Assy

1. Remove the pulley holder screw. Move the Y-CA pulley holder in the direction of arrow A and remove the Y-CA timing belt.
2. Move the Y-CA pulley holder in the direction of arrow B and remove it.
3. Move the Y-CA idle pulley in the direction of arrow B and remove it.
4. Remove the Y-CA driving pulley ring and pull off the Y-CA driving pulley.
5. Remove the two Y-CA motor screws and remove the Y-CA motor.

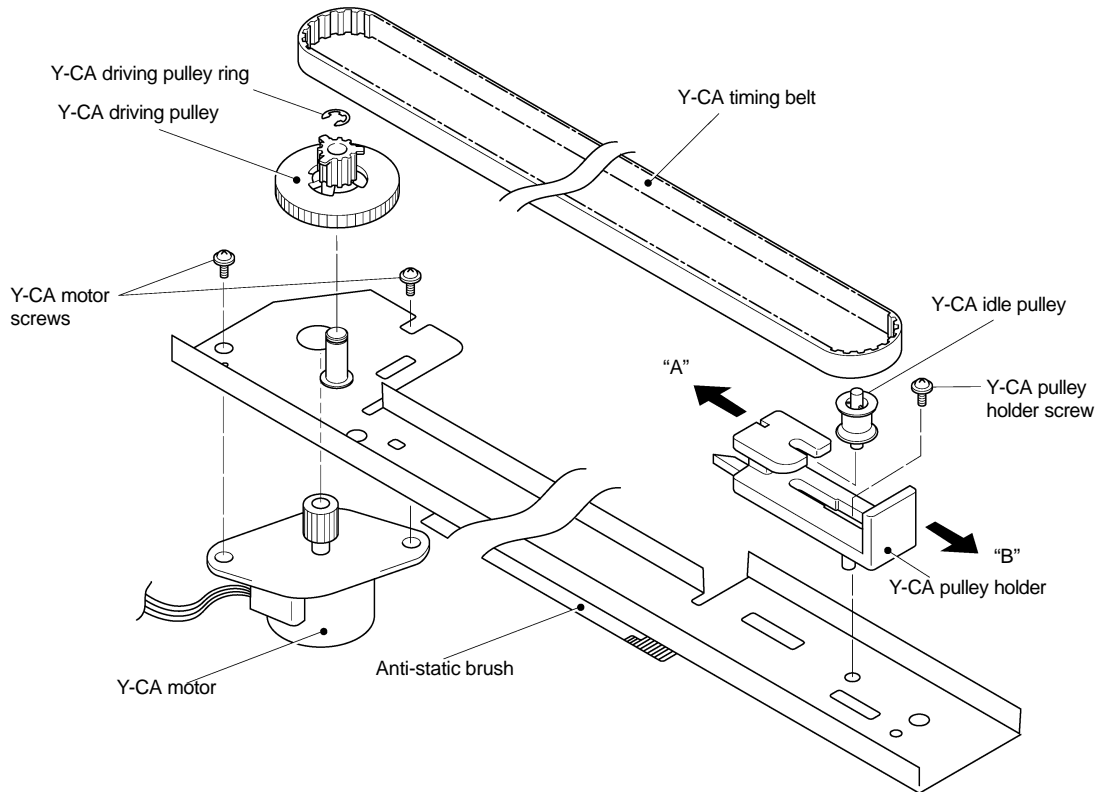

Fig. 3.7-2 Disassembling the Y-CA Chassis Assy

3.7.3 Removing the Roller Holder Assy

1. Move the Y-cutter arm L as far as possible to the left.
2. Lift up the roller holder assy and remove the roller holder spring.
3. Remove the two roller holder rings. Push the roller holder assy to the right to disengage it from the chassis unit L boss shaft. Disengage the roller holder assy from the chassis unit R boss shaft.

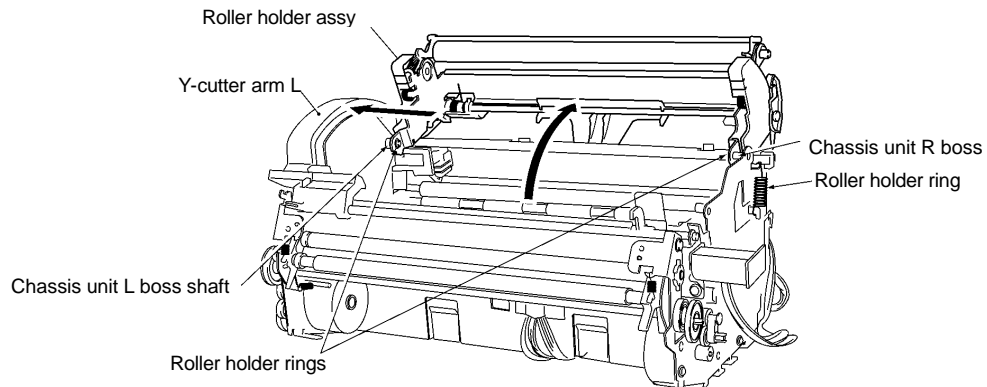

Fig. 3.7-3 Removing the Roller Holder Assy

3.7.4 Disassembling the Roller Holder Assy

1. Disengage the two hooks A and remove the side covers L/R.
2. Remove the lock lever springs L/R from inside the lock levers L/R to allow the lock levers L/R to move freely.
3. Turn hook B on lock lever L to the position of the cut-out on the roller holder and remove lock lever L. Pull out the lock lever shaft and remove the set buttons L/R, lock lever springs L/R, and the interference board.
4. Turn hook C on lock lever R to the position of the cut-out on the roller holder and remove lock lever R.
5. Remove the extension springs 0.4 from the left and right.
6. Pull the sub-roller bearings L/R out of the boss holes and remove them from the release plates L/R.
7. Remove the sub-roller bearings L/R, tape hold bearings L/R, and tape hold shaft from the sub-roller assy.
8. Remove the press roller springs L/R.
9. Remove the release plate rings. Remove the release plates L/R.

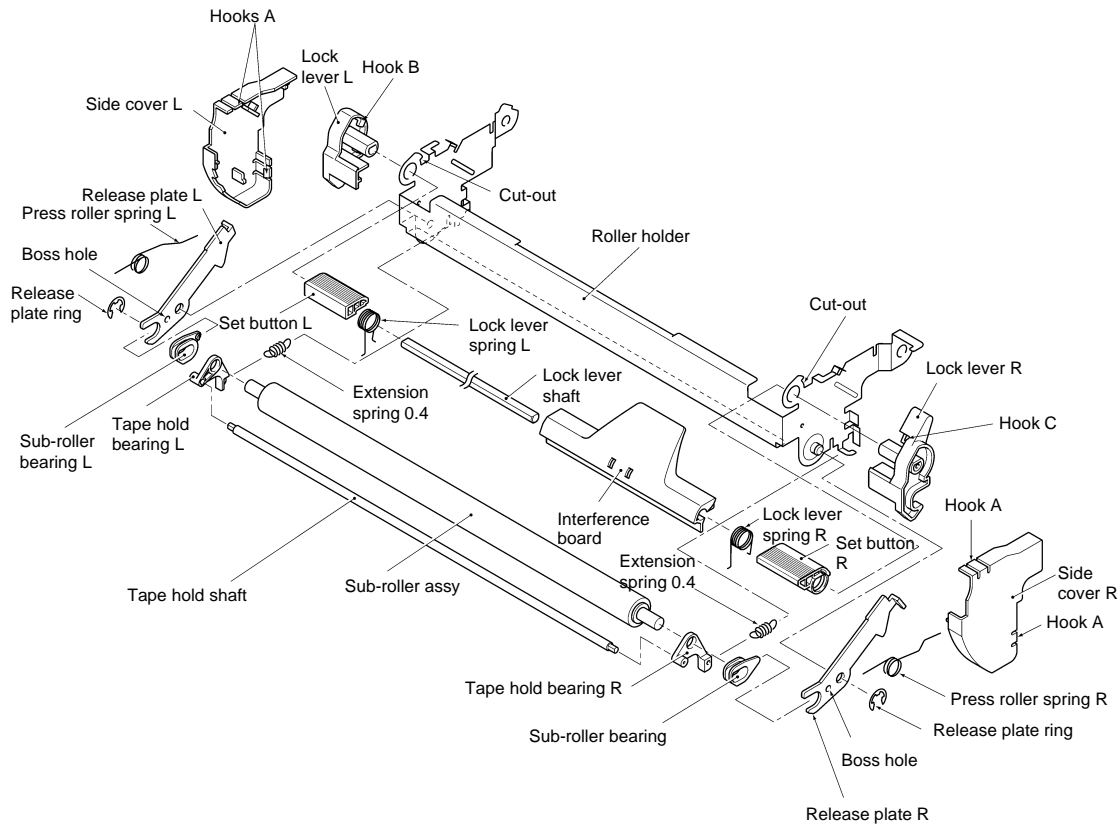

Fig. 3.7-4 Disassembling the Roller Holder Assy

3.8 Sensor Frame and Y-cutter Arm L

3.8.1 Removing the Sensor Frame

1. Position the chassis unit as shown in the diagram. Remove the paper sensor crank from the paper feed roller.
2. Remove the two sensor frame screws.
3. Lift the right end of the sensor frame to release it from the top-right boss. Move the sensor frame to the left to release it from the two bosses at the left. Remove the sensor frame.

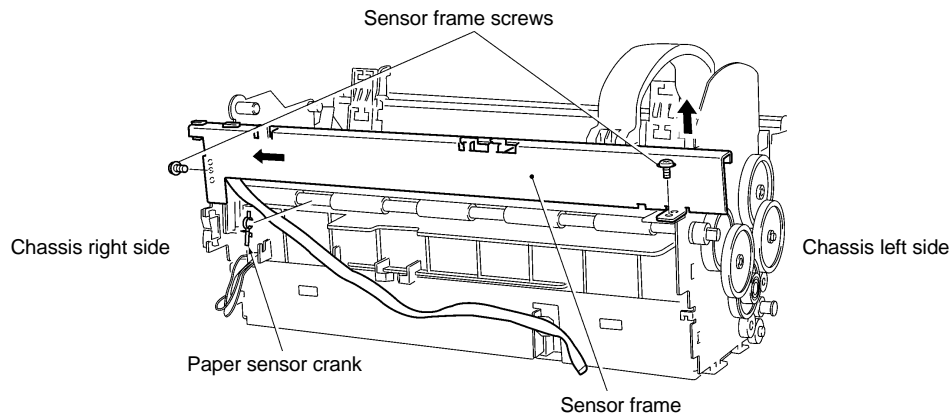

Fig. 3.8-1 Removing the Sensor Frame

3.8.2 Removing the Y-cutter Arm L

Remove the two arm shaft rings and pull the Y-cutter arm shaft in the direction of the arrow to remove the Y-cutter arm L.

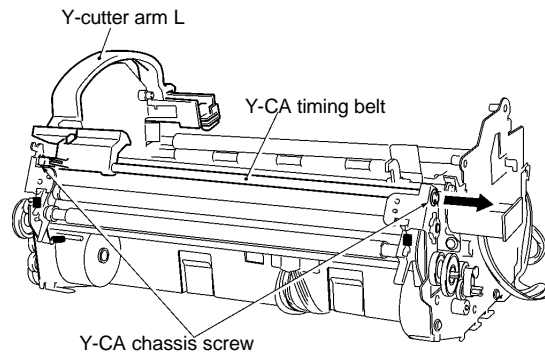

Fig. 3.8-2 Removing the Y-cutter Arm L

3.8.3 Disassembling the Sensor Frame

1. Disengage the hooks on FPC holder A from the cut-outs in the sensor frame. Move the FPC holder A in the direction of the arrow to remove it.
2. Release the FPC holder B from the boss hole in the sensor frame. Move the FPC holder B in the direction of the arrow to remove it.
3. Remove the paper sensor harness assy (flat cable) from the FPC holder A and FPC holder B.
4. Remove the sensor crank protect film from the sensor frame, if it requires replacing.

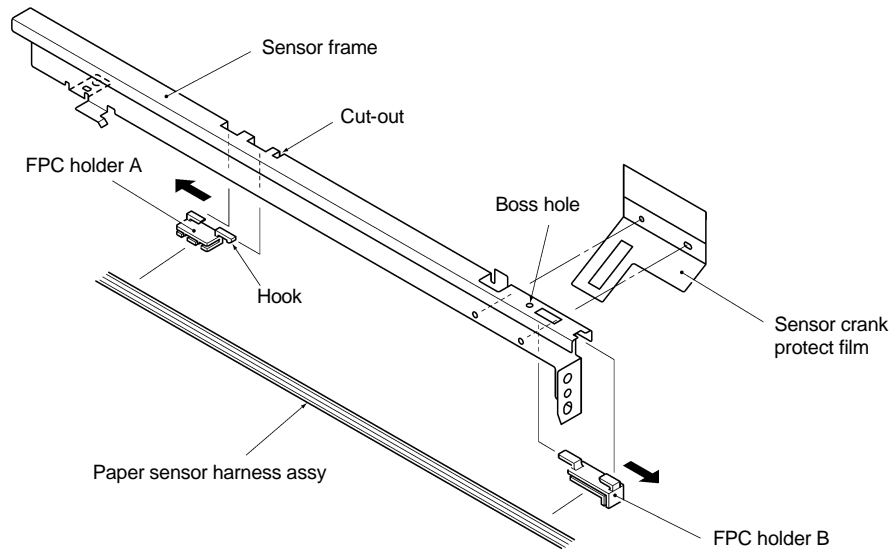

Fig. 3.8-3 Disassembling the Sensor Frame

3.8.4 Disassembling the Y-cutter Arm L

1. Remove the sensor holder screw. Remove the photosensor (PS) PCB holder from the Y-cutter arm L.
2. Disengage the PS PCB holder hook. Turn the PL detect lever to a position where it does not engage with the sensor, then remove it.
3. Remove the Y-CA sensor screw and remove the Y-CA sensor.

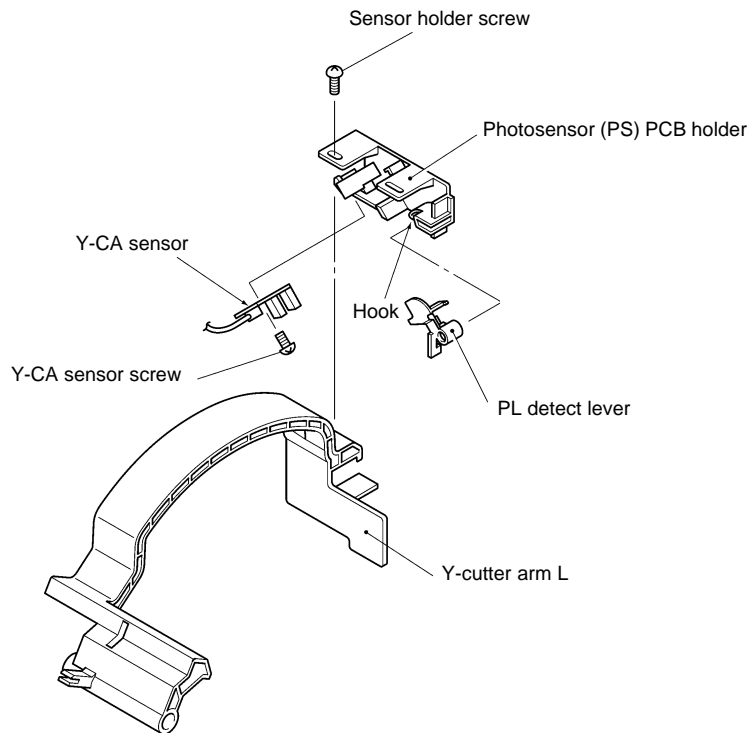

Fig. 3.8-4 Disassembling the Y-cutter Arm L

3.9 Paper Feed Roller

3.9.1 Removing the Paper Feed Sub-roller Assy

1. Position the chassis unit as shown in the diagram. Release the gear 16 hook from the paper feed sub-roller assy. Take care not to damage the gear hook by opening too far.
2. Remove the paper feed shaft spring R and paper feed shaft spring.

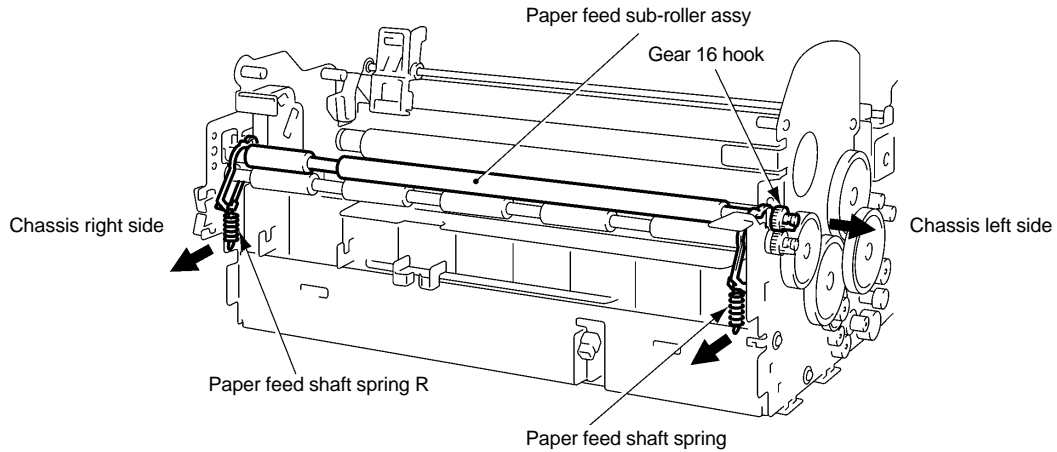

Fig. 3.9-1 Removing the Paper Feed Sub-roller Assy

3. Remove the left and right rod holder from the chassis L/R units. Pull the paper feed sub-roller assy up from the bearings to remove it.

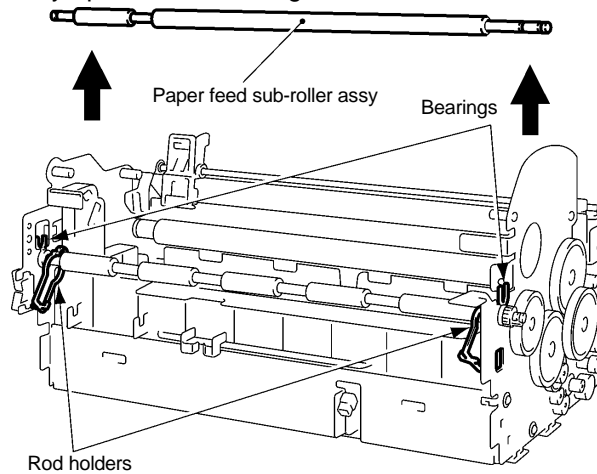

Fig. 3.9-2 Removing the Paper Feed Sub-roller Assy

3.9.2 Removing the Paper Feed Roller Assy

1. Position the chassis unit as shown in the diagram. Release the gear 16 hook from the paper feed sub-roller assy. Take care not to damage the gear hook by opening too far.
2. Remove the paper feed roller ring from the chassis right side.

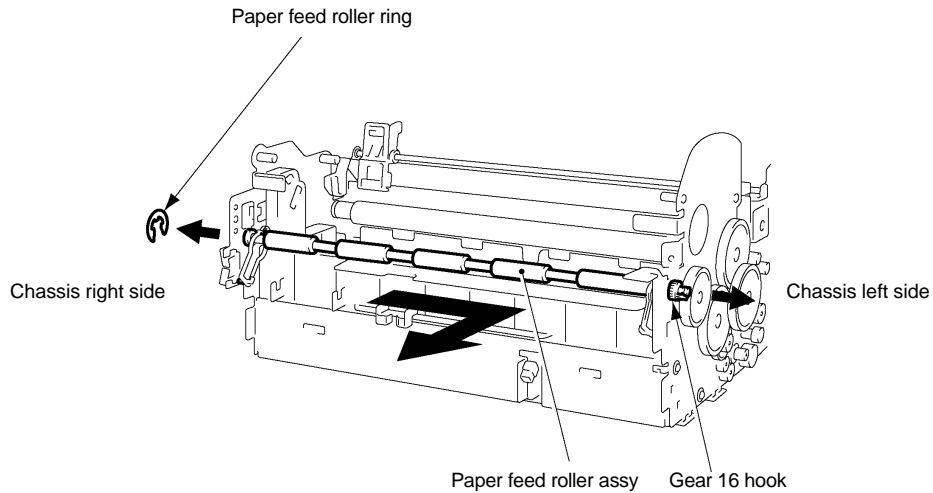

Fig. 3.9-3 Removing the Paper Feed Roller Assy (1)

3. Remove the left and right bearing.
4. Remove the paper feed roller assy from the left and right sides of the chassis.

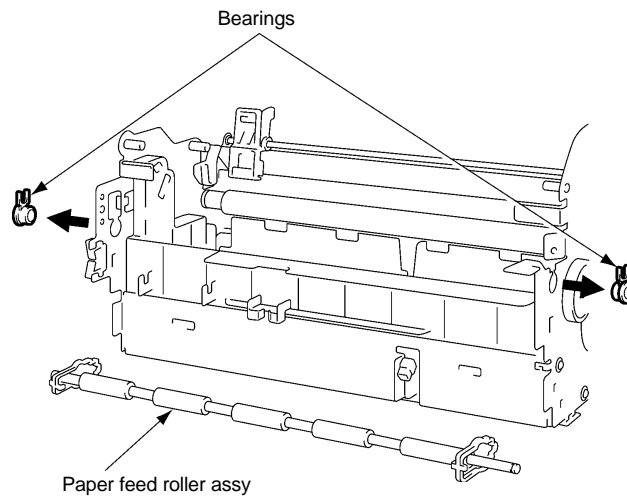

Fig. 3.9-4 Removing the Paper Feed Roller Assy (2)

3.10 Paper Eject Roller

3.10.1 Removing the Y-D Shaft

1. Remove the left and right paper eject sub-roller springs.
2. Remove the left and right Y-extension springs L/R.
3. Pull out the Y-gear 40-20 from the shaft and remove the Y-driving gear. Take care not to damage the gear hook by opening too far while removing the Y-gear 40-20.
4. Push the Y-D shaft to the right, then remove from the left.

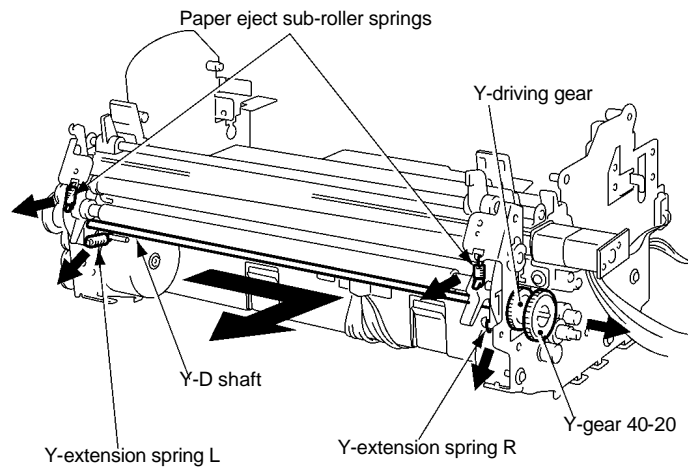

Fig. 3.10-1 Removing the Y-D Shaft (1)

5. Remove the Y-cutter cams L/R from the removed Y-D shaft.

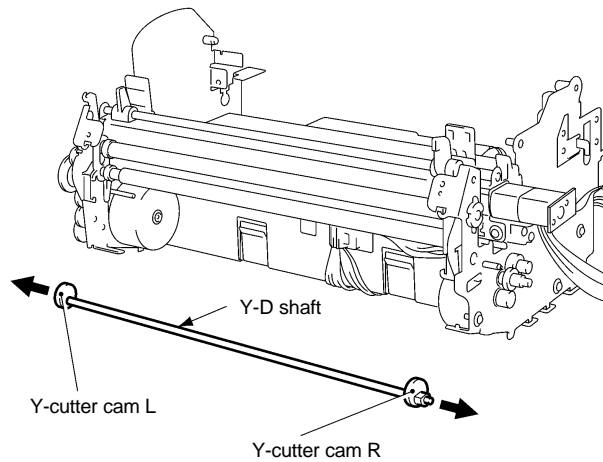

Fig. 3.10-2 Removing the Y-D Shaft (2)

3.10.2 Removing the Paper Eject Sub-roller Unit

1. Remove the paper eject shaft holders L/R attached to the paper eject sub-roller unit by pulling them from the paper eject roller shaft in the direction of the arrow.
2. Remove the paper eject shaft holders L/R from the removed paper eject sub-roller unit.

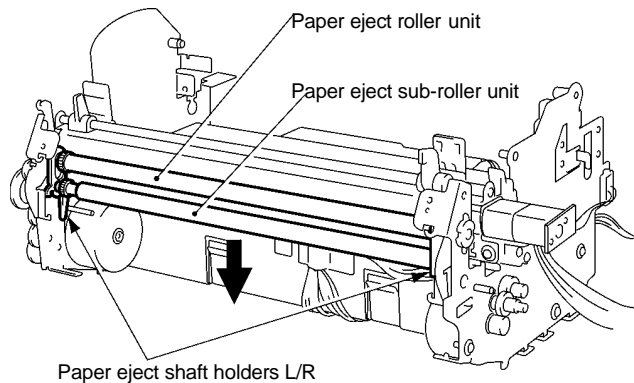

Fig. 3.10-3 Removing the Paper Eject Sub-roller Unit

3.10.3 Removing the Paper Eject Roller Unit

1. Pull out the Y-gear 40-16 from the shaft and remove the gear 20. Take care not to damage the gear hook by opening too far while removing the Y-gear 40-16.
2. Remove the gear 16 hook from the paper eject roller unit. Take care not to damage the gear hook by opening too far.
3. Turn the paper eject roller bearing L clockwise at the chassis left side with needle-nosed pliers and remove it. Remove the paper eject roller screw then turn the paper eject roller bearing R counterclockwise at the chassis right side with needle-nosed pliers and remove it.

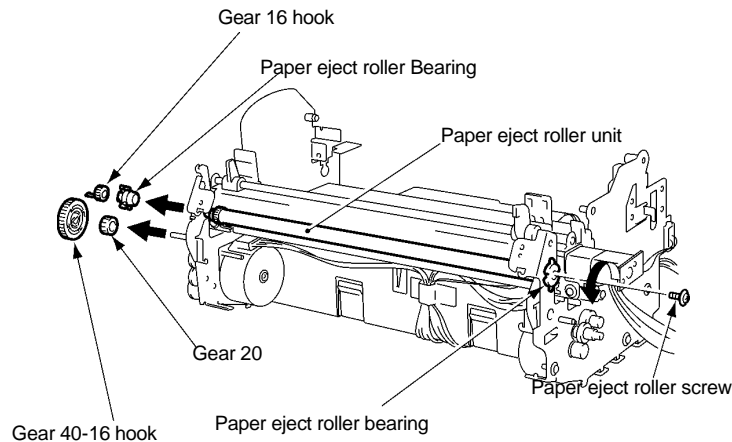

Fig. 3.10-4 Removing the Paper Eject Roller Unit (1)

4. Push the paper eject roller unit to the left, then remove from the right.

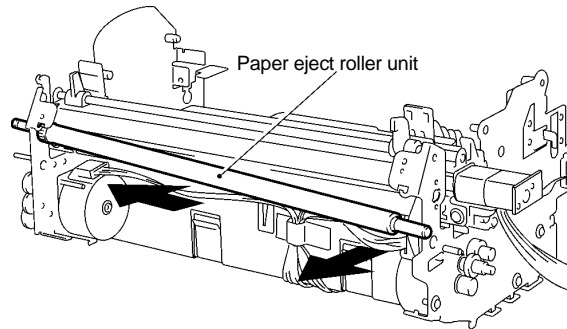

Fig. 3.10-5 Removing the Paper Eject Roller Unit (2)

3.11 Y-diversion Lever

3.11.1 Removing the Y-diversion Lever Assy

1. Press the tabs on the two Y-cutter units in the direction of arrow 1 to release the hooks. Move them down in the direction of arrow 2 and then in the direction of arrow 3 to release.

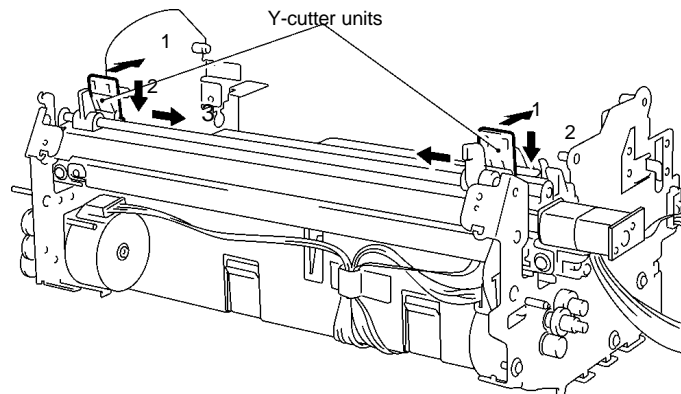

Fig. 3.11-1 Removing the Y-diversion Lever Assy (1)

2. Lift up the right end and the left end of the Y-diversion lever assy in sequence to remove it.

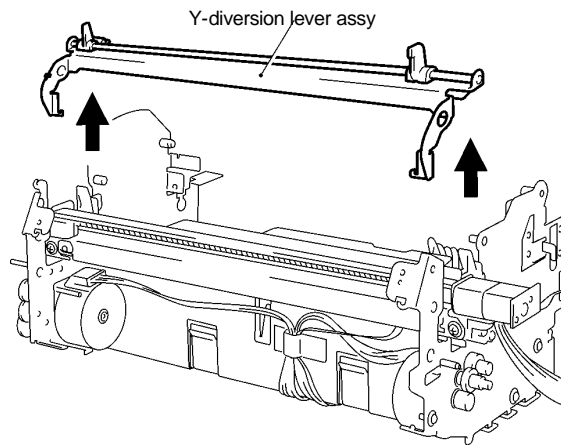

Fig. 3.11-2 Removing the Y-diversion Lever Assy (2)

3.11.2 Disassembling the Y-diversion Lever Assy

1. Release the two Y-cutter guide shaft rings from the right end.
2. Pull up the Y-cutter guide shaft then remove the Y-cutter guides L/R from each end.
3. Remove the Y-diversion lever film, if it requires replacing.

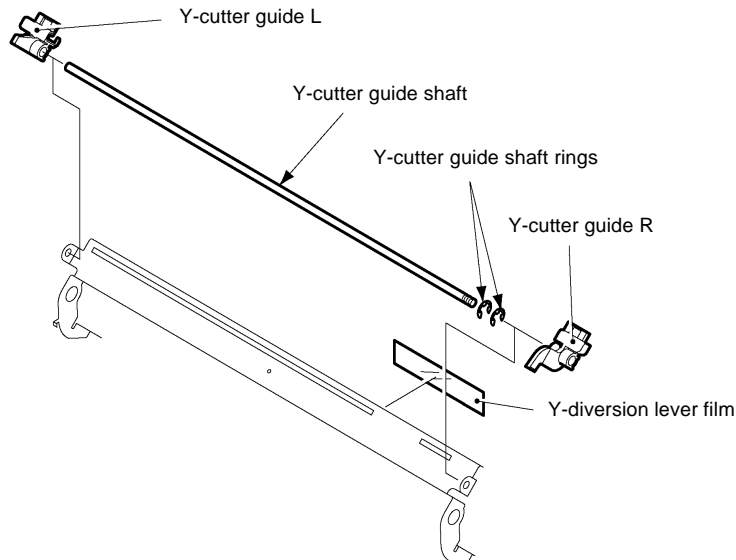

Fig. 3.11-3 Disassembling the Y-diversion Lever Assy

3.12 X-cutter

3.12.1 Removing the X-cutter Unit

1. Remove the two X-cutter screws. Lift up the X-cutter unit.

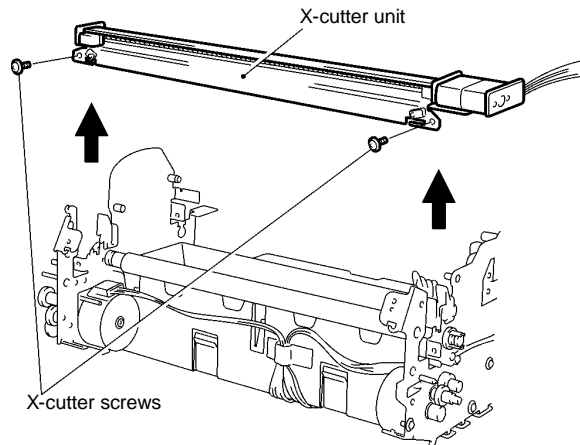

Fig. 3.12-1 Removing the X-cutter Unit

3.12.2 Disassembling the Tape Sensor Unit

1. Remove the leaf switch screw. Remove the leaf switch F Assy.
2. Remove the sensor holder screw. Remove the tape sensor holder from the X-cutter unit.
3. Remove the tape sensor lever from the tape sensor holder.

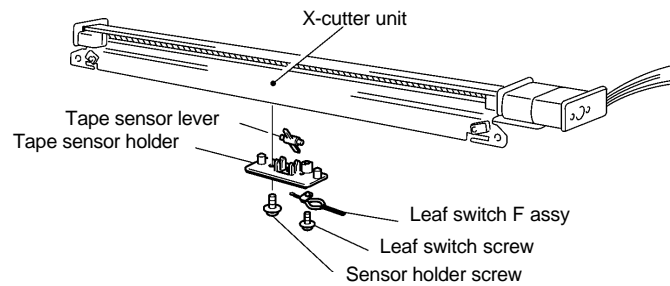

Fig. 3.12-2 Disassembling the Tape Sensor Unit

3.13 Driving Roller Shaft

3.13.1 Removing the Driving Roller Shaft

1. Remove the driving roller C ring. Remove the gear 16M1 hook and driving roller bearing. Take care not to open the driving roller C ring too far.
2. Remove the driving roller E ring. Remove the driving roller bearing.
3. Remove the driving roller shaft.

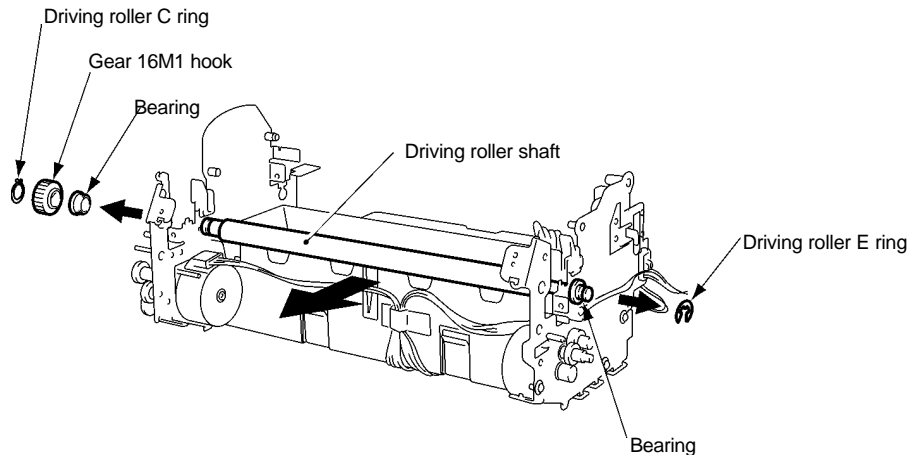

Fig. 3.13-1 Removing the Driving Roller

3.14 Left Side of the Chassis

3.14.1 Removing the Gears

Remove the gears from the left side of the chassis in the sequence described below.

If the gear has one or two hooks, disengage the hooks from the locking groove in the shaft before removing. Gear 20, removed at step 18 is fastened by a ring. Remove the ring before removing the gear.

1. Gear 37 hook
2. TY-planet gear unit

Remove the TY-planet gear holder, before removing the felt, TY-idle gear, and TY-spring washer from the shaft. Remove the TY-planet gear from the TY-planet gear holder.

3. Gear 25 hook
4. Planet 20 hook (two)

Remove the planet 20 hook, before removing the felt, TY-planet gear holder, TY-spring washer, and TY-planet gear.

5. Gear 36/12 hook
6. Gear 21
7. Gear 37 hook
8. Gear 21
9. Gear 40/16 hook (This is removed when removing the paper eject roller.)
10. Gear 21
11. Gear 20 (This is removed when removing the paper eject roller.)
12. Gear 60/20 hook
13. Gear 60/16M1
14. Gear 60/16
15. Gear 16M1
16. Gear 48/24
17. Gear 20
18. Gear 20
19. Gear 20
20. Gear 50

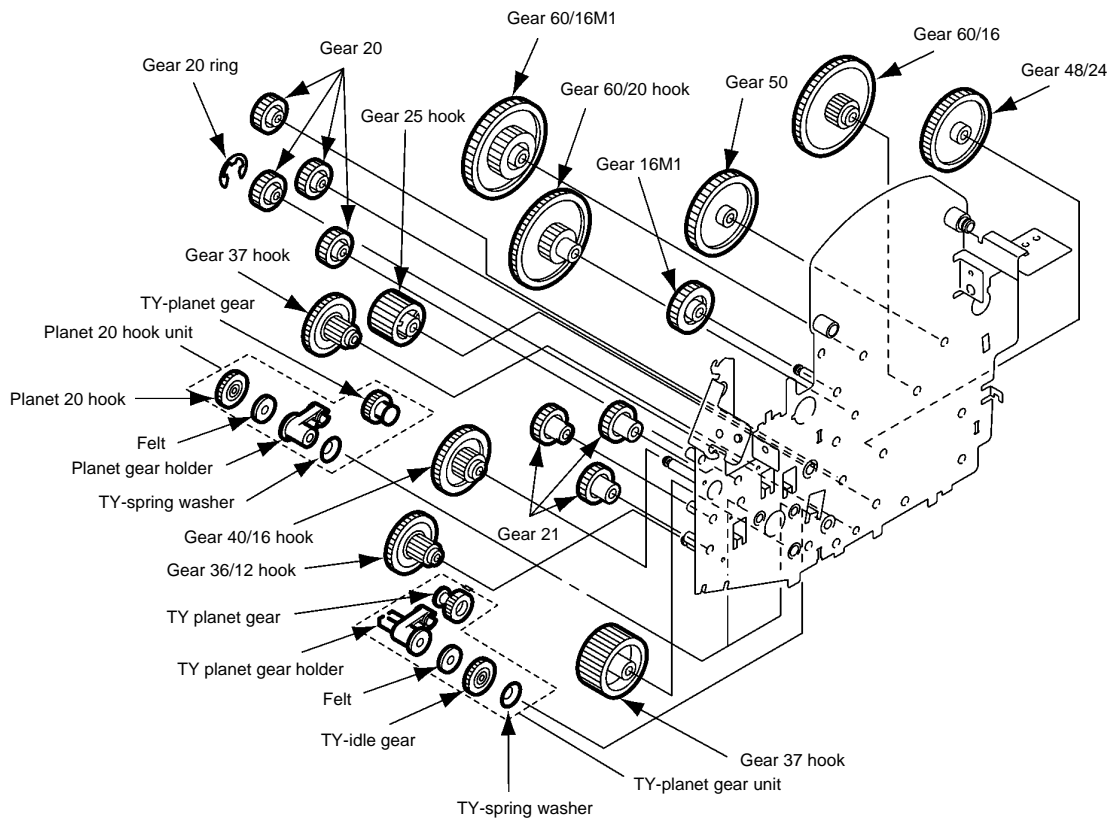

Fig. 3.14-1 Removing the Gears

3.14.2 Disassembling the Left Side of the Chassis

1. Release roller guide L from the boss hole. Incline the guide and remove it.
2. Remove the LF motor screw and TC/LF motor screw. Remove the LF motor.

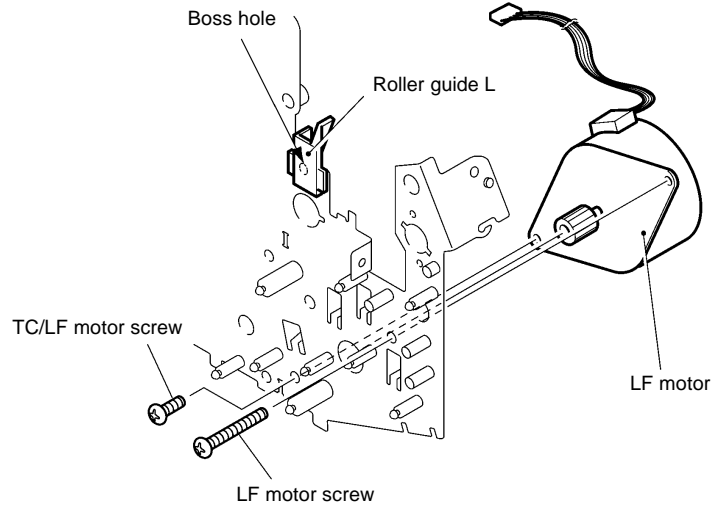

Fig. 3.14-2 Disassembling the Left Side of the Chassis

3.15 Right Side of the Chassis

3.15.1 Disassembling the Right Side of the Chassis

1. Remove the leaf switch Y screw. Remove the leaf switch Y assy.
2. Release the Y-sensor lever hook and remove the Y-sensor lever.
3. Incline the edging saddle EDS-1 and remove it.
4. Release roller guide R from the boss hole. Incline the guide and remove it.
5. Remove the TY-planet gear holder, before removing the felt, TY-idle gear, and TY-spring washer from the shaft. Take care not to damage the TY-planet gear holder hooks by opening too far.
6. Remove the TY-planet gear from the TY-planet gear holder.

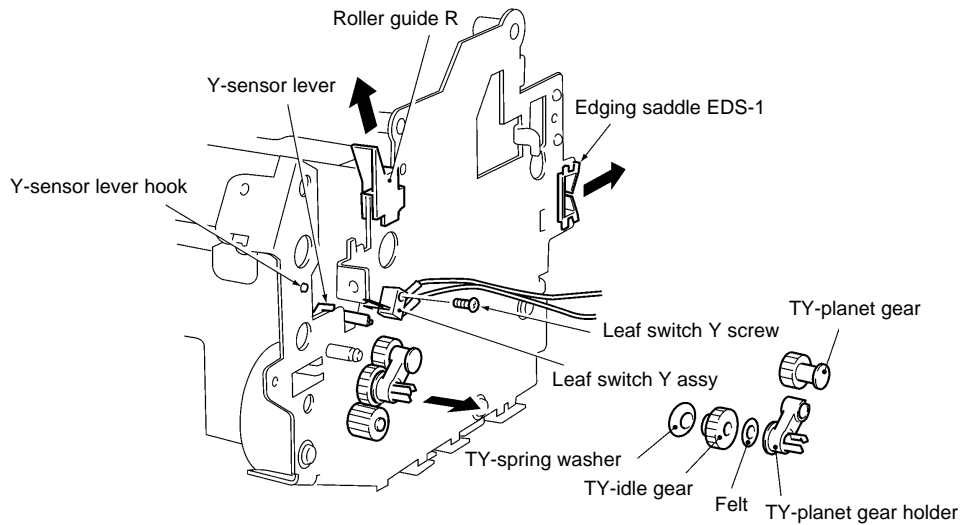

Fig. 3.15-1 Disassembling the Right Side of the Chassis (1)

7. Remove the two TC motor screws. Remove the TC motor.

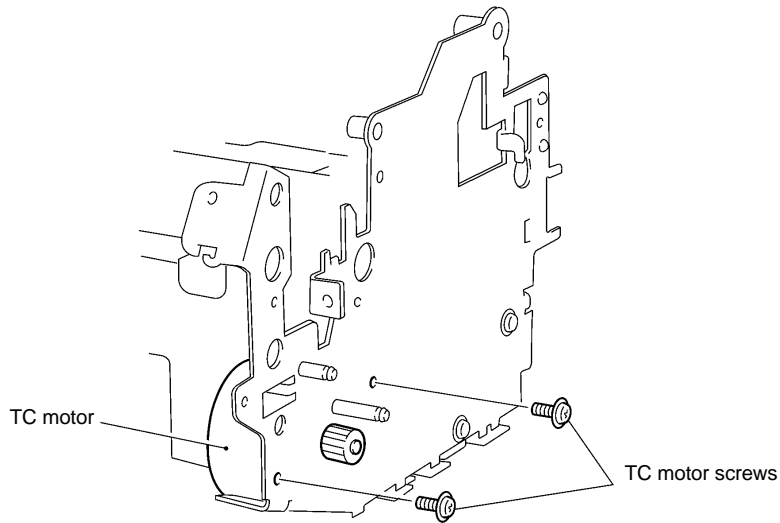

Fig. 3.15-2 Disassembling the Right Side of the Chassis (2)

3.16 Lower Chassis

3.16.1 Removing the Left and Right Sides of the Chassis

Remove the six side chassis screws and remove the left and right sides of the chassis.

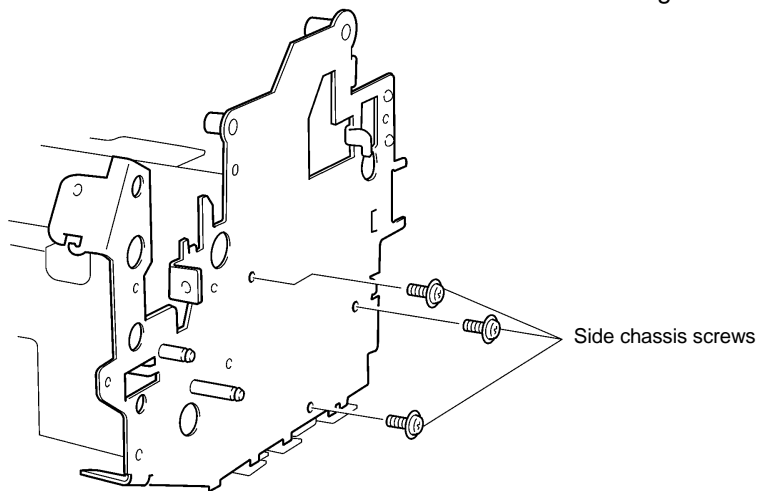

Fig. 3.16-1 Removing the Left and Right Sides of the Chassis

3.16.2 Removing the Cassette Holder

1. Release the two side hooks fastening the cassette holder.
2. Flex the rear face of the cassette holder inward to release the two lugs. Remove the cassette holder from the bottom chassis.

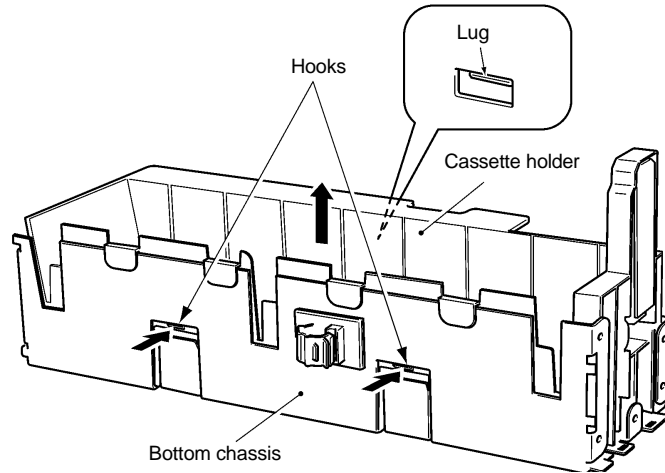

Fig. 3.16-2 Removing the Cassette Holder

3.16.3 Removing the Encoder (ENC) Sensor PCB

Remove the ENC sensor screw. Remove the ENC sensor assy.

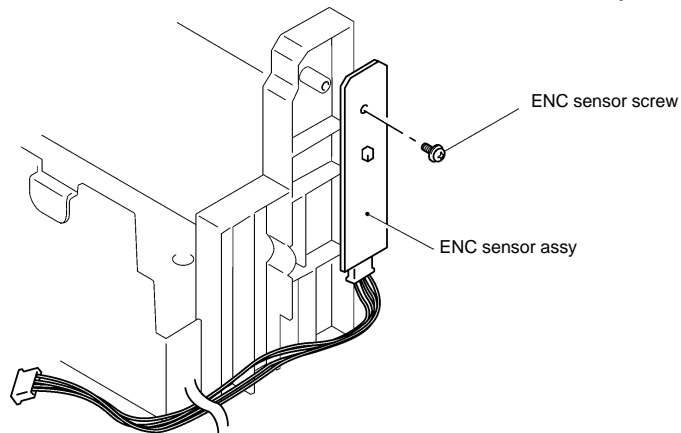

Fig. 3.16-3 Removing the ENC Sensor PCB

3.16.4 Removing the Cassette Detect Switch

Remove the leaf switch (SW) C screw. Remove the leaf switch C Assy.

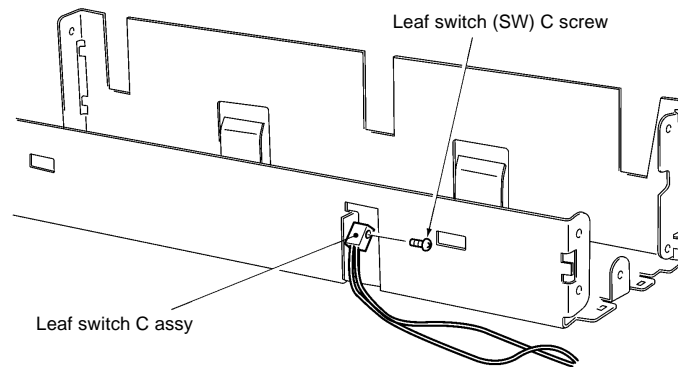

Fig. 3.16-4 Removing the Cassette Detect Switch

Chapter 4.

REASSEMBLY PROCEDURES

CONTENTS

Chapter 4. REASSEMBLY PROCEDURES

4.1	Safety Precautions	4-1
4.2	Table of Tightening Torque	4-1
4.3	Lower Chassis	4-2
4.3.1	Installing the Cassette Detect Switch.....	4-2
4.3.2	Installing the Encoder (ENC) Sensor PCB	4-2
4.3.3	Installing the Cassette Holder	4-3
4.3.4	Installing the Left and Right Sides of the Chassis	4-3
4.4	Right Side of the Chassis	4-4
4.4.1	Reassembling the Right Side of the Chassis.....	4-4
4.5	Left Side of the Chassis	4-6
4.5.1	Reassembling the Left Side of the Chassis	4-6
4.5.2	Installing the Gears	4-6
4.6	Driving Roller Shaft.....	4-9
4.6.1	Installing the Driving Roller Shaft.....	4-9
4.7	X-cutter	4-10
4.7.1	Reassembling the Tape Sensor Unit	4-10
4.7.2	Installing the X-cutter Unit.....	4-10
4.8	Y-diversion Lever.....	4-11
4.8.1	Reassembling the Y-diversion Lever Assy	4-11
4.8.2	Installing the Y-diversion Lever Assy	4-12
4.9	Paper Eject Roller.....	4-13
4.9.1	Installing the Paper Eject Roller Unit	4-13
4.9.2	Installing the Paper Eject Sub-roller Unit	4-15
4.9.3	Installing the Y-D Shaft	4-15
4.10	Paper Feed Roller	4-17
4.10.1	Installing the Paper Feed Roller Assy.....	4-17
4.10.2	Installing the Paper Feed Sub-roller Assy	4-18
4.11	Sensor Frame and Y-cutter Arm L	4-19
4.11.1	Reassembling the Y-cutter Arm L	4-19
4.11.2	Reassembling the Sensor Frame	4-20
4.11.3	Installing the Y-cutter Arm L.....	4-21
4.11.4	Installing the Sensor Frame	4-22
4.12	Roller Holder.....	4-22
4.12.1	Reassembling the Roller Holder Assy	4-22
4.12.2	Installing the Roller Holder Assy	4-24
4.13	Y-CA Chassis	4-25
4.13.1	Reassembling the Y-CA Chassis Assy.....	4-25
4.13.2	Installing the Y-CA Chassis Assy.....	4-26

4.14 T-Chassis.....	4-27
4.14.1 Reassembling the T-Chassis Unit.....	4-27
4.14.2 Installing the T-Chassis Unit	4-28
4.15 PCBs.....	4-29
4.15.1 Installing the Switch PCB Assy	4-29
4.15.2 Installing the Jack PCB Assy	4-30
4.15.3 Installing the Main PCB Assy.....	4-30
4.16 Chassis	4-31
4.16.1 Installing the Chassis Unit.....	4-31
4.16.2 Installing the PE Sensor Unit	4-32
4.16.3 Installing the Harness Connectors	4-33
4.17 Covers	4-33
4.17.1 Reassembling the Dial Switch Holder Assy B	4-33
4.17.2 Installing the Dial Switch Holder Assy B	4-35
4.17.3 Installing the Cover Switch Assy	4-36
4.17.4 Installing the Front Cover.....	4-37
4.17.5 Installing the Body Cover	4-38
4.17.6 Installing the Paper Tray and Paper Guide.....	4-41
4.17.7 Installing the Sub-tray	4-42
4.17.8 Installing the Top Cover	4-42
4.17.9 Installing the Trimmer Upper Cover	4-43
4.18 Installing the Film Cartridge.....	4-44

4.1 Safety Precautions

- When conducting reassembly operations, place the unit on a grounded anti-static sheet. LSI and other electronic components are sensitive to static electricity and may be damaged if touched while charged.
- Before transporting a circuit board, wrap it in a conducting sheet such as aluminum foil.
- When using a soldering iron or other heat-producing tool, ensure that heat does not damage wires, circuit boards, or plastic parts such as covers.
- Take care not to lose small screws or washers removed when replacing parts.
- Tighten all screws to the torque specified in the table below.

4.2 Table of Tightening Torque

Name of Screw	Qty.	Screw Size	Tightening Torque	See Page
Leaf switch (SW) C screw	1	SCREW FLANGED 2.6 × 8	0.196 to 0.392N•m	4-2
ENC sensor screw	1	TAPTITE, BIND B M2.6 × 6	0.196 to 0.392N•m	4-2
Side chassis screw	6	TAPTITE, CUP M3 × 5	0.49 to 0.686N•m	4-3
TC/LF motor screw	2	SCREW, BIND M3 × 6	0.49 to 0.686N•m	4-4
Leaf switch Y screw	1	PAN-HEAD MACHINE SCREW M2.6 × 8	0.196 to 0.392N•m	4-5
TC/LF motor screw	1	TAPTITE, CUP M3 × 6	0.49 to 0.686N•m	4-6
LF motor screw	1	TAPTITE, CUP M3 × 16	0.49 to 0.686N•m	4-6
X-cutter screw	2	TAPTITE, CUP M 3 × 5	0.49 to 0.686N•m	4-10
Leaf switch screw	1	TAPTITE, PAN B M2 × 6	0.196 to 0.392N•m	4-10
Sensor holder screw	1	TAPTITE BIND B M2.6 × 6	0.686 to 0.882N•m	4-10
Paper eject roller screw	1	TAPTITE, CUP M3 × 5	0.49 to 0.686N•m	4-14
Y-CA sensor screw	1	TAPTITE, BIND B M2.6 × 6	0.196 to 0.392N•m	4-19
Sensor holder screw	1	TAPTITE, BIND B M2.6 × 6	0.196 to 0.392N•m	4-19
Sensor frame screw	2	TAPTITE, CUP M3 × 5	0.49 to 0.686N•m	4-22, 32
Y-CA motor screw	2	SCREW, FLANGED M2.6 × 5	0.196 to 0.392N•m	4-25
Y-CA pulley holder screw	1	TAPTITE, CUP M3 × 5	0.49 to 0.686N•m	4-25
Y-CA frame screw	2	TAPTITE, CUP M3 × 5	0.49 to 0.686N•m	4-26
Leaf switch TRI screw	1	TAPTITE, PAN B M2 × 6	0.196 to 0.392N•m	4-27
Paper guide screw	1	SCREW, BIND M3 × 6	0.49 to 0.686N•m	4-27
Leaf switch TRG screw	1	PAN-HEAD MACHINE SCREW M2.6 × 8	0.196 to 0.392N•m	4-27
T-chassis unit screw	2	TAPTITE, CUP M3 × 5	0.49 to 0.686N•m	4-28
Plate spring screw	1	TAPTITE, CUP M3 × 5	0.49 to 0.686N•m	4-28
Switch PCB screw A	2	TAPTITE, BIND B M3 × 12	0.49 to 0.686N•m	4-29
Switch PCB screw B	3	TAPTITE, BIND B M3 × 14	0.49 to 0.686N•m	4-29
Jack PCB screw	1	TAPTITE, BIND B M 3 × 8	0.49 to 0.686N•m	4-30
Main PCB screw	4	TAPTITE, BIND B M3 × 8	0.49 to 0.686N•m	4-30
Cassette holder screw	4	TAPTITE, CUP B M4 × 12	0.98 to 1.176N•m	4-31
Bottom cover screw B	2	TAPTITE, BIND B M3 × 8	0.49 to 0.686N•m	4-31
Slide plate screw	1	TAPTITE, BIND B M3 × 8	0.49 to 0.686N•m	4-34
Slide plate spring screw	1	SCREW, FLANGED M2.6 × 5	0.196 to 0.392N•m	4-34

Name of Screw	Qty.	Screw Size	Tightening Torque	See Page
Leaf switch R/L screw	2	PAN-HEAD MACHINE SCREW M2.6 × 8	0.196 to 0.392N•m	4-35
Dial holder screw	2	TAPTITE,BIND B M3 × 8	0.49 to 0.686N•m	4-35
Cover switch screw	1	PHILLIPS PAN-HEAD TAPTILE B M2.6 × 12	0.49 to 0.686N•m	4-36
Front cover screw	2	TAPTITE,BIND B M2.6X6	0.294 to 0.49N•m	4-37
Bottom cover screw A	2	TAPTITE,BIND B M3X12	0.196 to 0.392N•m	4-40
Trimmer cover screw	2	SCREW,BIND M3 × 6	0.49 to 0.686N•m	4-43

4.3 Lower Chassis

4.3.1 Installing the Cassette Detect Switch

Align the leaf switch C assy with the boss hole in the lower chassis and fasten it in position with the leaf switch (SW) C screw. Take care not to deform the tip of the leaf switch C assy during installation.

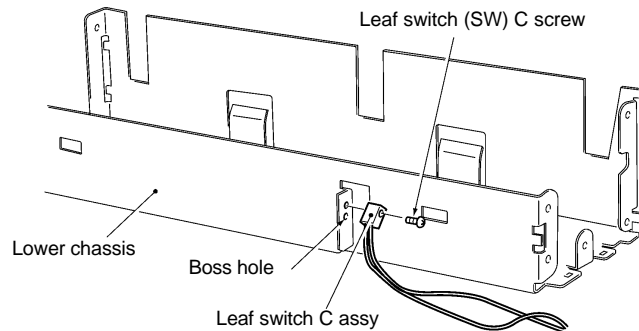

Fig. 4.3-1 Installing the Cassette Detect Switch

4.3.2 Installing the Encoder (ENC) Sensor PCB

Align the ENC sensor assy with the two bosses. Fasten the assembly to the cassette holder with the ENC sensor screw.

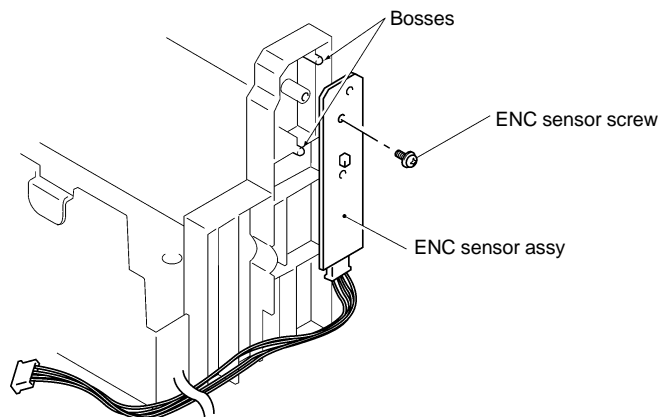

Fig. 4.3-2 Installing the ENC Sensor PCB

4.3.3 Installing the Cassette Holder

Engage the two side hooks and four claws on the cassette holder with the bottom chassis. Insert the two rear lugs into the slots to fasten the cassette holder.

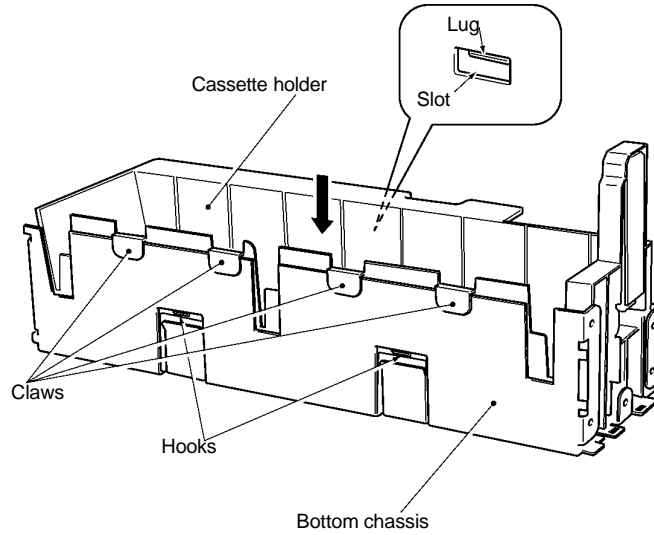

Fig. 4.3-3 Installing the Cassette Holder

4.3.4 Installing the Left and Right Sides of the Chassis

Insert the two lugs on the left or right side of the chassis into the rectangular holes in the lower chassis. Fasten each side chassis in position with the three side chassis screws.

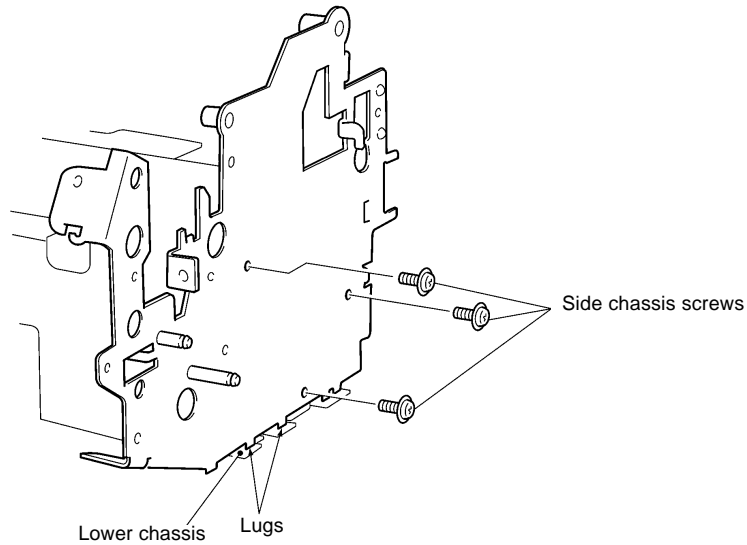

Fig. 4.3-4 Installing the Left and Right Sides of the Chassis

4.4 Right Side of the Chassis

4.4.1 Reassembling the Right Side of the Chassis

1. Attach the TC motor with the two TC/LF motor screws.

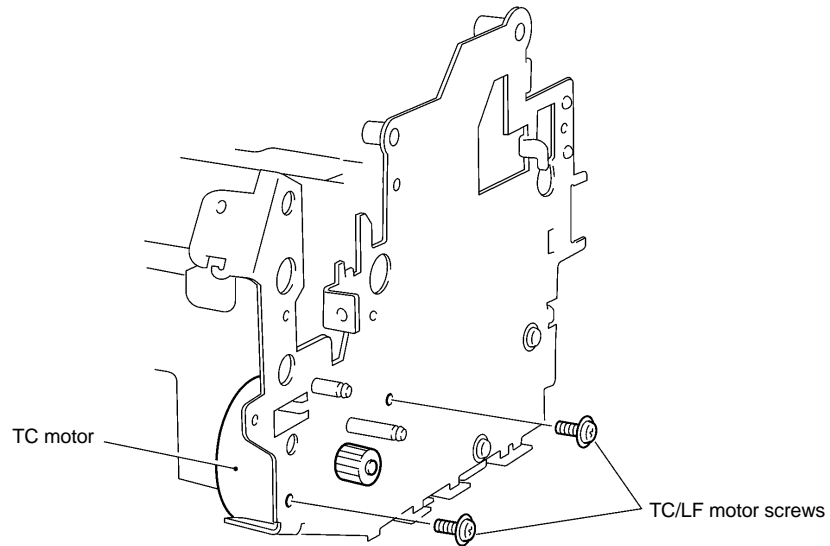

Fig. 4.4-1 Reassembling the Right Side of the Chassis (1)

2. Put the TY-spring washer, TY-idle gear, and felt (stick onto the TY-idle gear) on the shaft.
3. Attach the TY-planet gear to the TY-planet gear holder. Put the TY-planet gear holder on the shaft and push it until the hooks engage.
4. Incline the roller guide R and push the cut-out and align the roller guide R with the boss hole A to engage with chassis R.
5. Incline the edging saddle EDS-1 and push it into position.
6. Align the Y-sensor lever hook with boss hole B in the chassis R and push it into hooking position.
7. Align the leaf switch Y assy with the chassis R boss hole C and fasten it in position with the leaf switch Y screw. Install the contacts of the leaf switch Y assy over the Y-sensor lever.

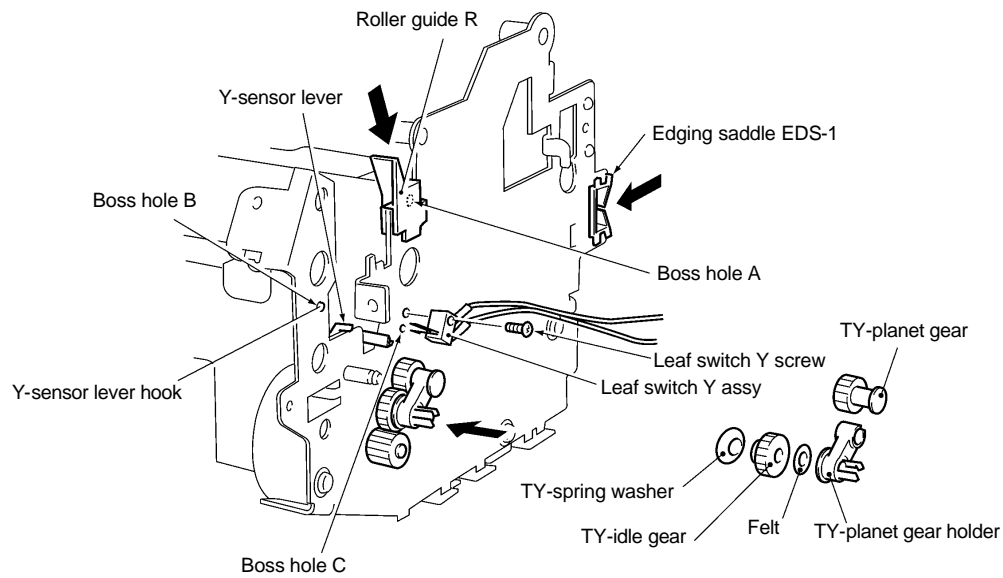

Fig. 4.4-2 Reassembling the Right Side of the Chassis (2)

4.5 Left Side of the Chassis

4.5.1 Reassembling the Left Side of the Chassis

1. Fasten the LF motor with one TC/LF motor screw and one LF motor screw.
2. Incline the roller guide L. Insert the cut-out into chassis L and push it into place until the hooks engage in the boss hole.

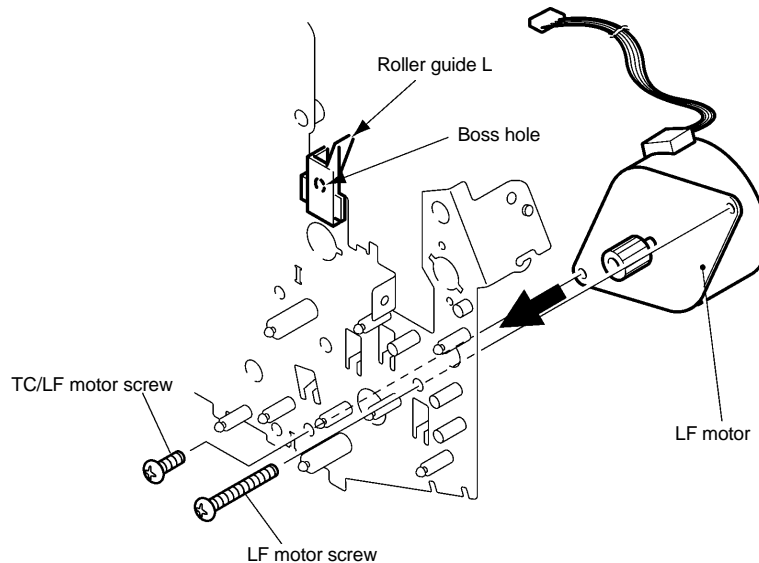

Fig. 4.5-1 Reassembling the Left Side of the Chassis

4.5.2 Installing the Gears

Install the gears at the left side of the chassis in the sequence described below.

If the gear (or holder) has one or two hooks, push it into place until the hooks engage in the locking groove in the shaft.

Gear 20, installed at step 3, is fastened by a ring.

1. Gear 50
2. Gear 20
3. Gear 20
4. Gear 20
5. Gear 48/24 (48-tooth side against chassis)
6. Gear 16M1
7. Gear 60/16 (16-tooth side against chassis)
8. Gear 60/16M1 (16-tooth side against chassis)
9. Gear 60/20 hook
10. Gear 20
11. Gear 21
12. Gear 40/16 hook

13. Gear 21
14. Gear 37 hook
15. Gear 21
16. Gear 36/12 hook
17. Planet 20 hook (two)

Attach the TY-planet gear to the planet gear holder. Put the TY-spring washer, planet gear holder, felt (stick onto the TY-planet gear holder), and planet 20 hook on the shaft.

18. Gear 25 hook
19. TY-planet gear unit

Attach the TY-planet gear to the TY-planet gear holder. Put the TY-spring washer, TY-idle gear, felt (stick onto the TY-idle gear), and TY-planet gear holder on the shaft.

20. Gear 37 hook

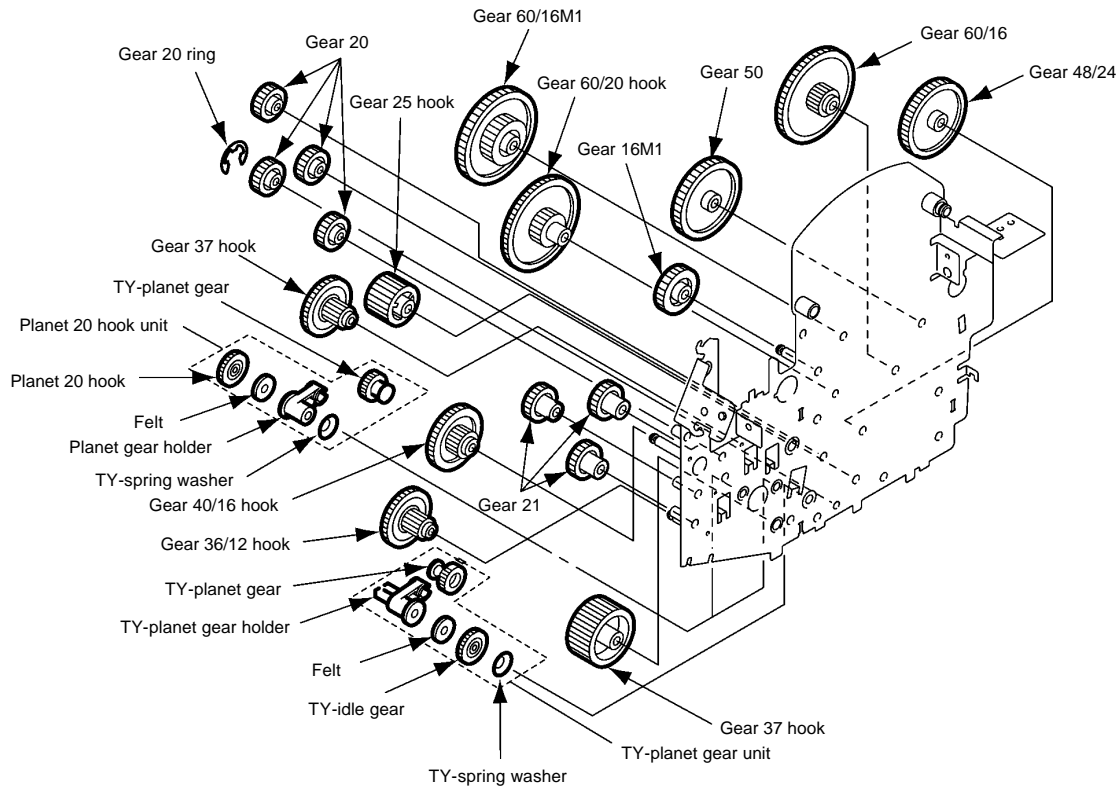

Fig. 4.5-2 Installing the Gears (1)

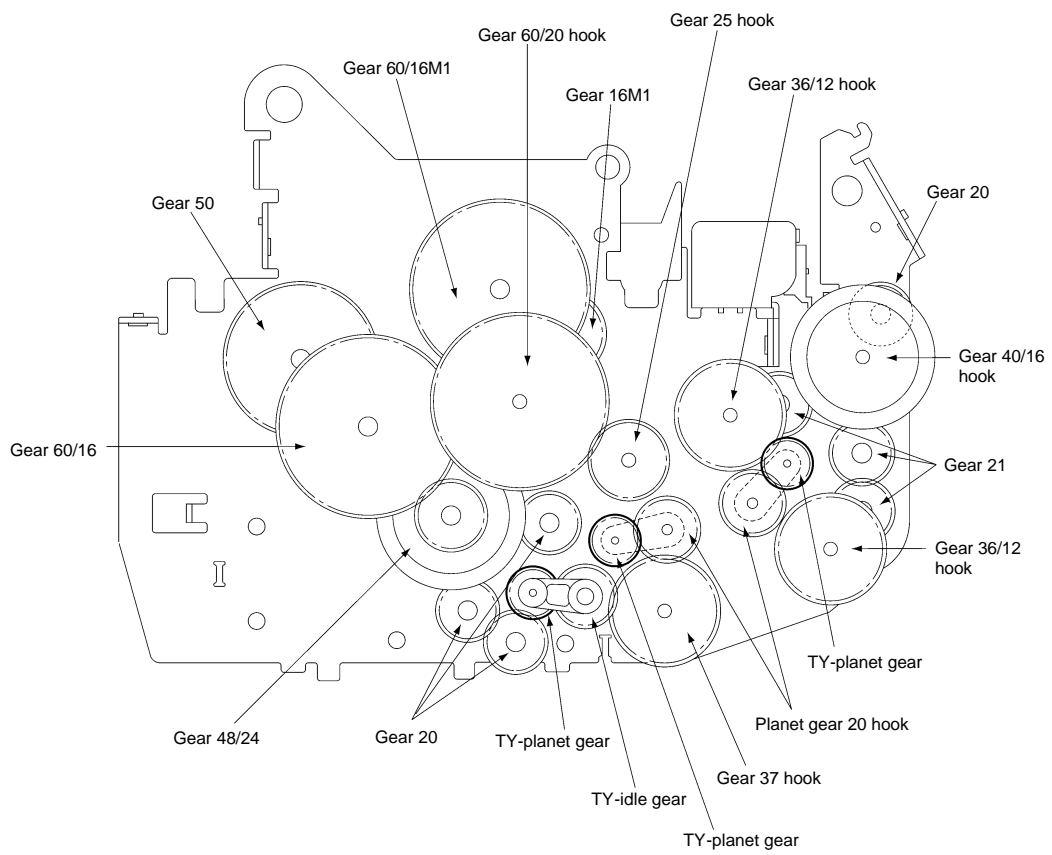

Fig. 4.5-3 Installing the Gears (2)

4.6 Driving Roller Shaft

4.6.1 Installing the Driving Roller Shaft

1. Insert the semicircular end of the driving roller shaft into the hole in chassis L.
2. Put the driving roller bearing from the left and attach it to chassis L. (Align the lug on the bearing with the cut-out in the chassis.)
3. Insert the right end of the driving roller shaft into the hole in chassis R.
4. Put the driving roller bearing from the right and attach it to chassis R. (Align the lug on the bearing with the cut-out in the chassis.)
5. Fasten the right end of the driving roller shaft with the driving roller E ring.
6. Put the gear 16M1 hook on the left end of the driving roller shaft and fasten it with the driving roller C ring. Take care not to open the driving roller C ring too far.

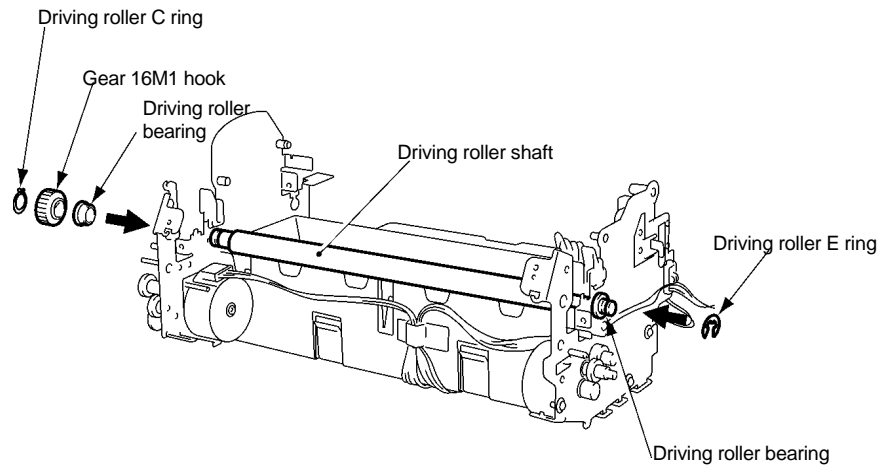

Fig. 4.6-1 Installing the Driving Roller Shaft

4.7 X-cutter

4.7.1 Reassembling the Tape Sensor Unit

1. Fasten the leaf switch F Assy to the tape sensor holder with the leaf switch screw.
2. Attach the tape sensor lever to the tape sensor holder.
3. Attach the tape sensor holder to the X-cutter unit with the sensor holder screw.

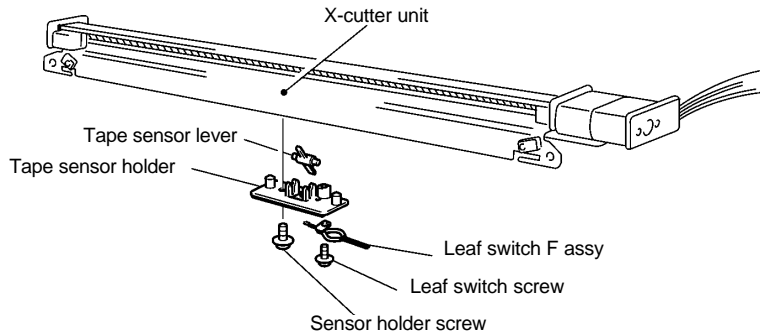

Fig. 4.7-1 Reassembling the Tape Sensor Unit

4.7.2 Installing the X-cutter Unit

Install the X-cutter unit into the chassis unit from above. Fasten it in position with the two X-cutter screws.

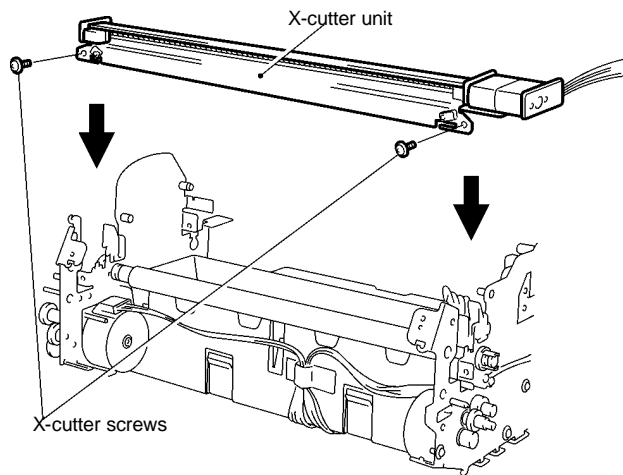

Fig. 4.7-2 Installing the X-cutter Unit

4.8 Y-diversion Lever

4.8.1 Reassembling the Y-diversion Lever Assy

1. Hold the Y-cutter guide shaft with the two rings at the right end. Insert the left end into Y-cutter guide L and the right end into Y-cutter guide R.
2. Insert the Y-cutter guide shaft through the holes in the Y-diversion lever. Fasten with the two Y-cutter guide shaft rings.
3. Stick new Y-diversion lever film on the Y-diversion lever, if it requires replacing.

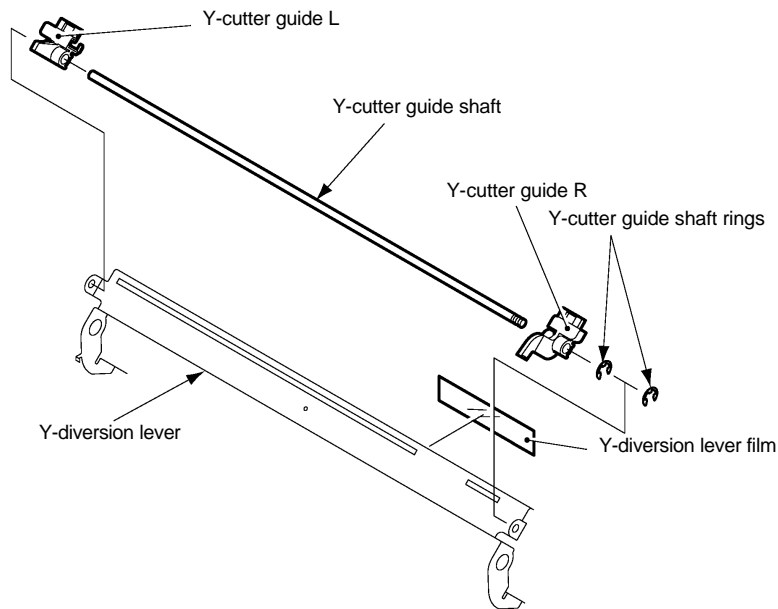

Fig. 4.8-1 Reassembling the Y-diversion Lever Assy

4.8.2 Installing the Y-diversion Lever Assy

1. Mount the Y-diversion lever assy on the X-cutter unit by inserting the left end into chassis L then the right end into chassis R.

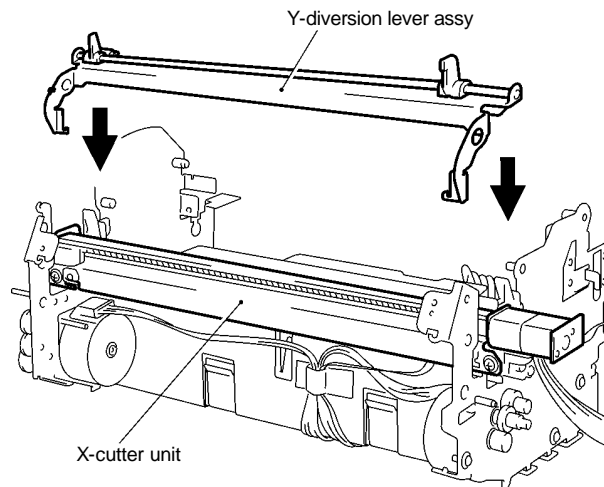

Fig. 4.8-2 Installing the Y-diversion Lever Assy 1

2. Press each of the two Y-cutter assy's against the Y-diversion lever assy and move it in the direction of arrow 1 up to the position of the Y-cutter guide L/R.
3. Install the Y-cutter guides by lifting the tab on each Y-cutter assy in the direction of arrow 2, then pushing in the direction of arrow 3 to engage the hook.

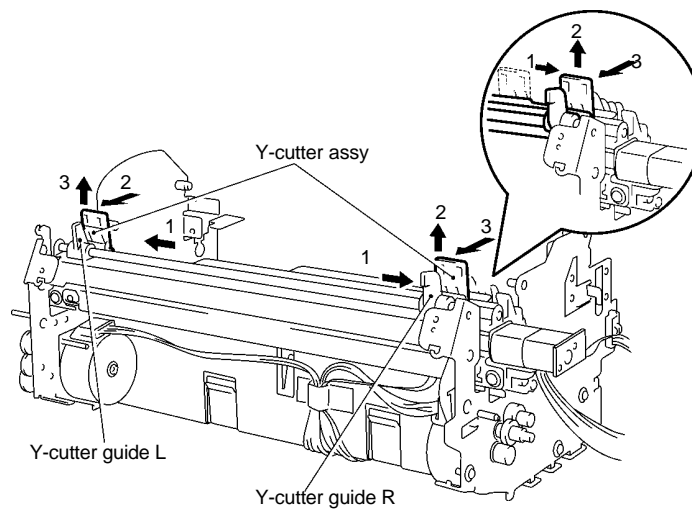

Fig. 4.8-3 Installing the Y-diversion Lever Assy 2

4.9 Paper Eject Roller

4.9.1 Installing the Paper Eject Roller Unit

1. Temporarily remove gear 40-16 and gear 20 when installing the paper eject roller unit, as these can interfere with the installation.
2. Hold the paper eject roller unit with the end where the gears mount at the left. Insert the left end into the hole in chassis L, then the right end into the hole in chassis R.

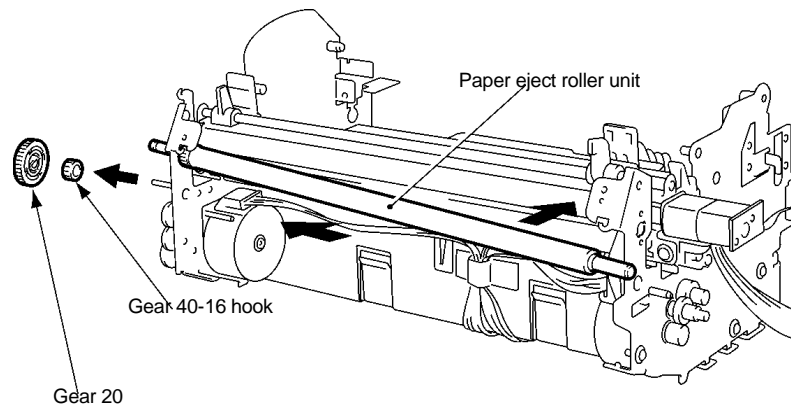

Fig. 4.9-1 Installing the Paper Eject Roller Unit (1)

3. Insert the left and right paper eject roller bearings into the chassis L/R. The paper eject roller bearings can only be inserted if the lugs on the bearings are aligned with the grooves in the chassis.
4. Turn the paper eject roller bearing L counterclockwise to the boss hole to insert it in the chassis left side. Likewise, turn the paper eject roller bearing R clockwise to the boss hole to insert it in the chassis right side.
5. After inserting the paper eject roller bearing R in the chassis right side, fasten it in position with the paper eject roller screw.
6. Align the gear 16 hook with the semicircular end of the paper eject roller unit and push the gear until the hook engages.
7. Replace gear 40-16 hook and gear 20 which were temporarily removed previously.

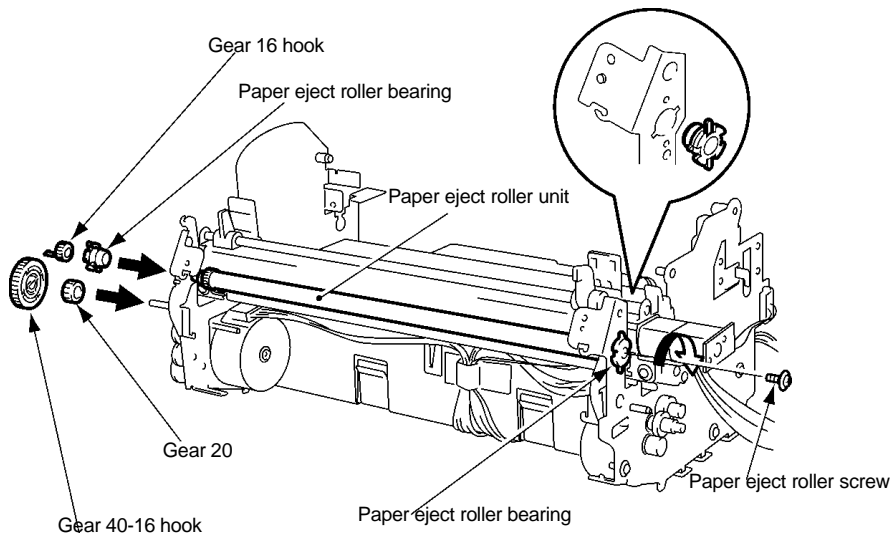

Fig. 4.9-2 Installing the Paper Eject Roller Unit (2)

4.9.2 Installing the Paper Eject Sub-roller Unit

1. Orient the left paper eject shaft holder L (narrow) and right paper eject shaft holder R (wide) with the flat face inward and attach them to the paper eject sub-roller unit.
2. Attach the paper eject shaft holders L/R attached to paper eject sub-roller unit to the paper eject roller shaft in the chassis.

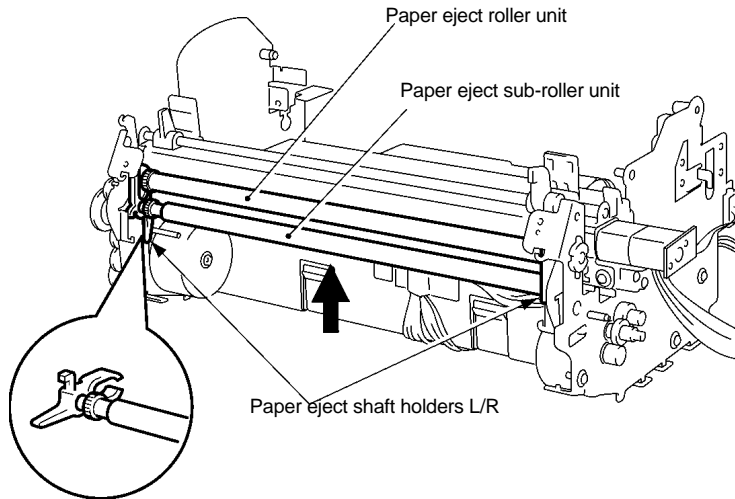

Fig. 4.9-3 Installing the Paper Eject Sub-roller Unit

4.9.3 Installing the Y-D Shaft

1. Align the Y-D shaft with the long semicircular end to the right. Align the Y-cutter cams L/R with each semicircular end of the Y-D shaft and attach them to the shaft.

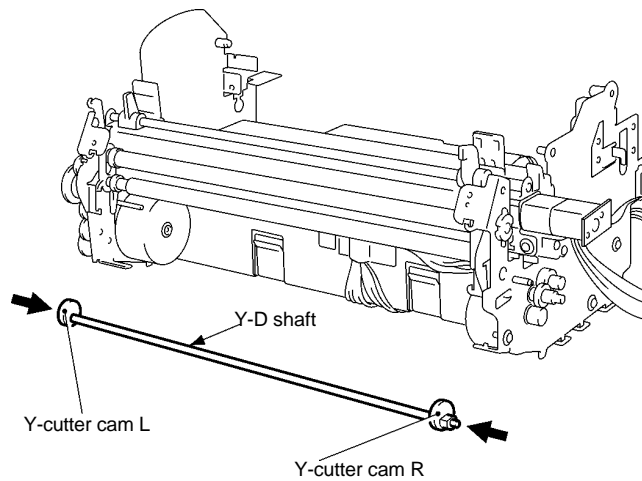
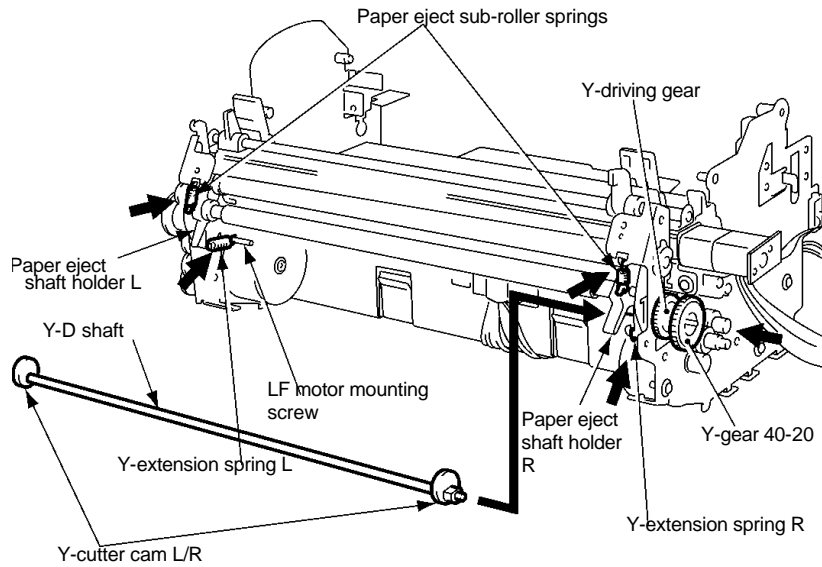

Fig. 4.9-4 Installing the Y-D Shaft (1)

2. Insert the Y-D shaft (with cams) first into chassis R, then into chassis L. The Y-D shaft should be inserted behind the paper eject shaft holders L/R.
3. Put the Y-driving gear onto the right semicircular end of the Y-D shaft. Next put the Y-gear 40-20 on this shaft and push the gear until the hook engages.
4. Attach the left and right Y-extension springs (L/R). Attach the Y-extension spring L (the longer one) to the LF motor mounting screw.
5. Attach the left and right paper eject sub-roller springs.



4.10 Paper Feed Roller

4.10.1 Installing the Paper Feed Roller Assy

1. Insert the bearings into the chassis L/R.
2. Attach the left and right rod holders to the paper feed roller assy with the hooks inward.

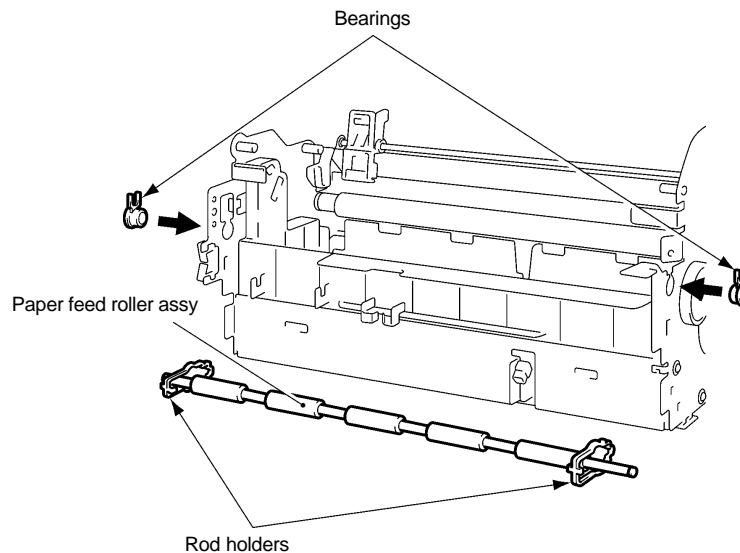

Fig. 4.10-1 Installing the Paper Feed Roller Assy (1)

3. Hold the paper feed roller assy with the semicircular end to the right. Insert the right bearing, then insert the left bearing. Fasten by attaching the paper feed roller ring to the shaft.
4. Align the gear 16 hook with the semicircular end of the paper feed roller assy and push the gear until the hook engages.

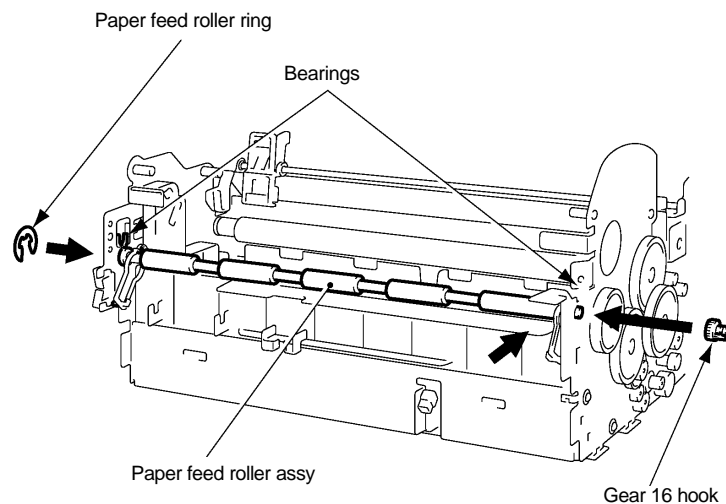

Fig. 4.10-2 Installing the Paper Feed Roller Assy (2)

4.10.2 Installing the Paper Feed Sub-roller Assy

1. Hold the paper feed sub-roller assy with the semicircular end to the right. Push through the left and right rod holders and engage the paper feed roller grooves in the bearings.

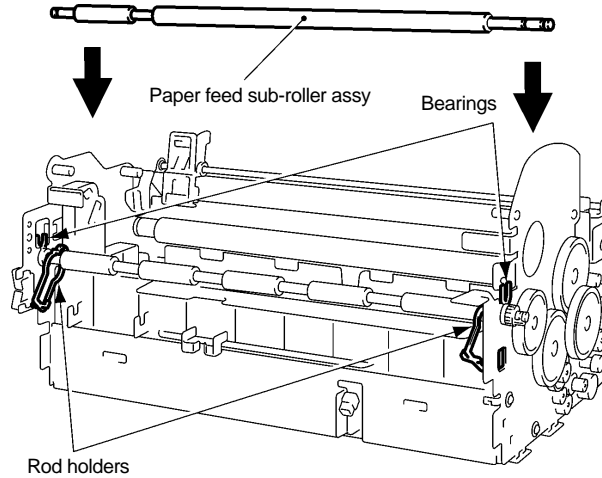

Fig. 4.10-3 Installing the Paper Feed Sub-roller Assy (1)

2. Align the lower boss of the left and right rod holders with the slots in the chassis L/R.
3. Attach the left and right paper feed shaft spring (L/R).
4. Align the gear 16 hook with the semicircular end of the paper feed sub-roller assy and push the gear until the hook engages.

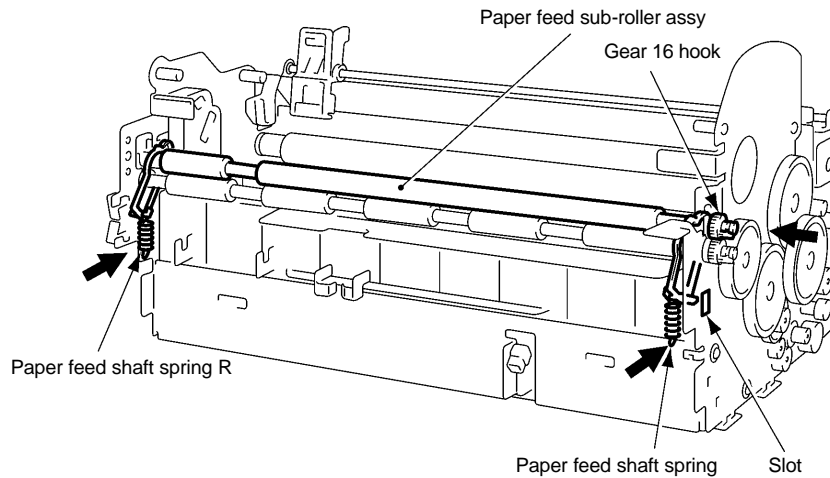

Fig. 4.10-4 Installing the Paper Feed Sub-roller Assy (2)

4.11 Sensor Frame and Y-cutter Arm L

4.11.1 Reassembling the Y-cutter Arm L

1. Fasten the Y-CA sensor to the photosensor (PS) PCB holder with the Y-CA sensor screw.
2. Put the PL detect lever on the photosensor (PS) PCB holder shaft. Turn the PL detect lever to the position where the sensor is cut off and push it until the hook engages.
3. Align the boss hole in the photosensor (PS) PCB holder with the Y-cutter arm L and fasten it in position with the sensor holder screw.

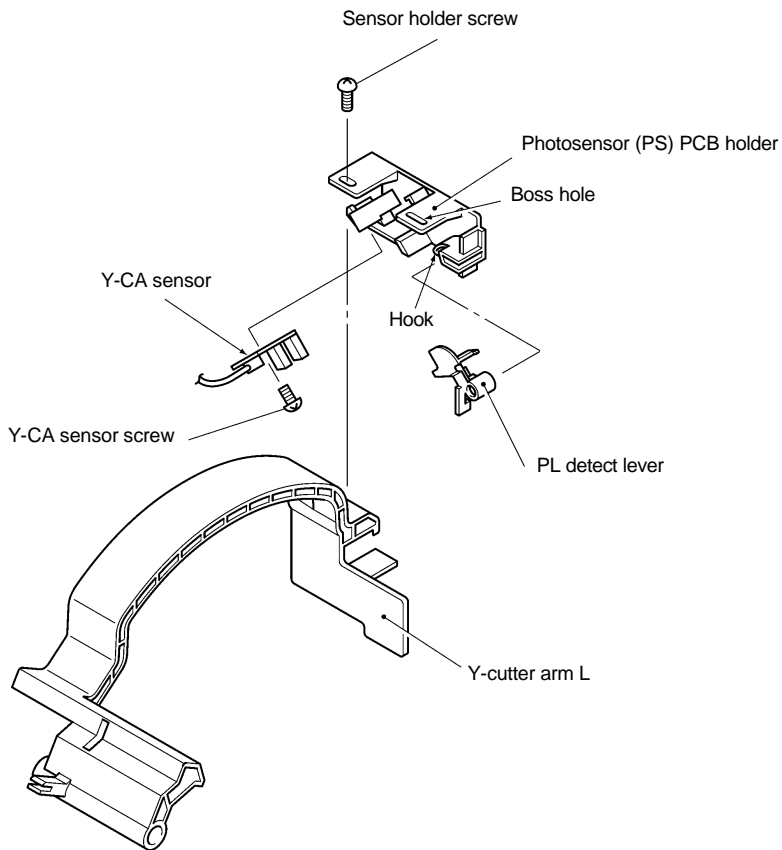

Fig. 4.11-1 Reassembling the Y-cutter Arm L

4.11.2 Reassembling the Sensor Frame

1. Attach the paper sensor harness assy (flat cable) to the FPC holder A and FPC holder B.
2. Insert the hooks on FPC holder A into slots A in the sensor frame. Attach FPC holder A by moving it in the direction of the arrow until the hook tip engages in the groove.
3. Insert the hooks on FPC holder B into slot B and the end hole in the sensor frame. Attach FPC holder B by moving it in the direction of the arrow until it engages with the boss holes.
4. Stick new sensor crank protect film aligned with the sensor frame boss, if the film requires replacing.

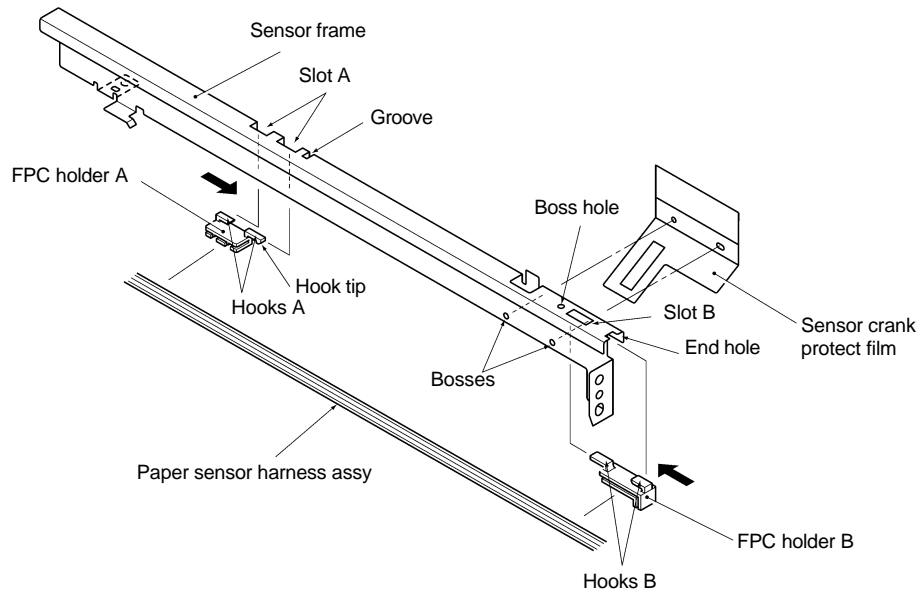

Fig. 4.11-2 Reassembling the Sensor Frame

4.11.3 Installing the Y-cutter Arm L

1. Engage the lug on Y-cutter guide L with the groove in Y-cutter arm L. Insert the Y-cutter arm shaft in Y-cutter arm L.
2. Insert the Y-cutter arm shaft in holes in the chassis L/R. Fasten with the two arm shaft rings.

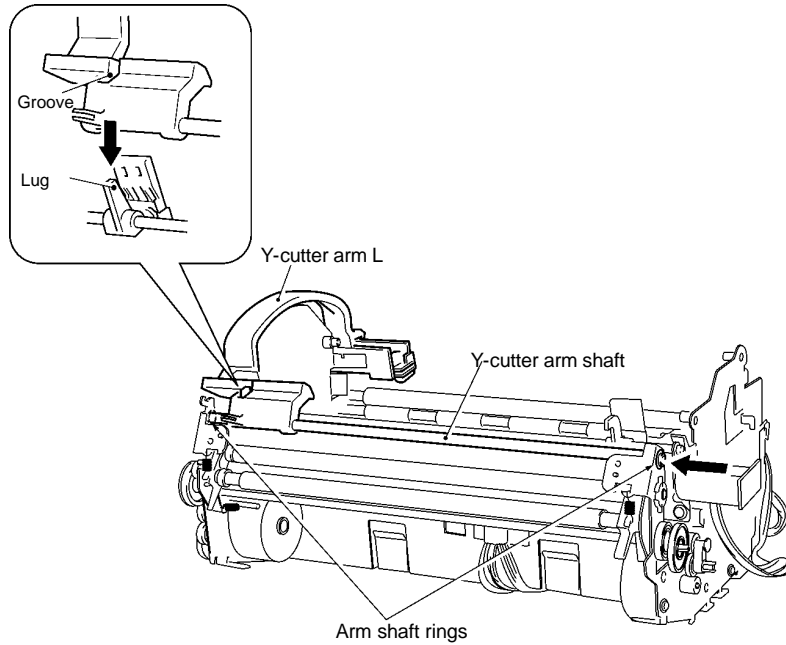

Fig. 4.11-3 Installing the Y-cutter Arm L

4.11.4 Installing the Sensor Frame

1. Align the left end of the sensor frame with boss A on the side of chassis R. Align the right end of the sensor frame above boss B on chassis L.
2. Insert the paper sensor crank through the cut-out in the in the sensor crank protective film and engage it with the paper feed roller unit shaft. Pass the bottom edge of the sensor crank protective film between the paper feed sub-roller and the paper feed roller.
3. Fasten into place with the two sensor frame screws.

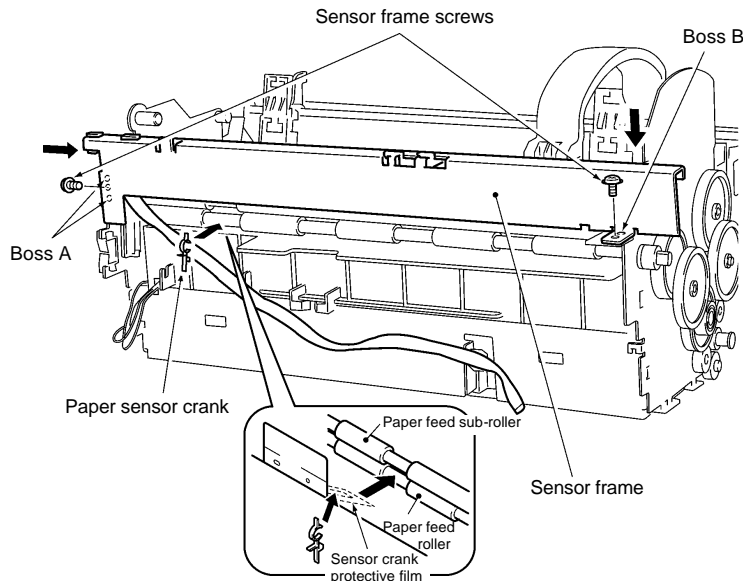

Fig. 4.11-4 Installing the Sensor Frame

4.12 Roller Holder

4.12.1 Reassembling the Roller Holder Assy

1. Put the release plates L/R onto the roller holder shaft and fasten them with the release plate rings.
2. Insert the round part of the press roller springs into part A of the roller holder assy. Make sure that the long leg of each press roller spring faces outward.
3. Attach the sub-roller bearings L/R and tape hold bearings L/R to the sub-roller assy. Install the tape hold shaft into the semicircular holes in the tape hold bearings L/R.
4. Align the sub-roller bearings L/R with the boss holes and attach them to the release plates L/R.
5. Hook the left and right extension springs 0.4 in the holes in the tape hold bearings L/R, then install by hooking the springs on part B of the roller holder assy.
6. Put the lock lever spring R on the set button R and attach them to the lock lever R through the roller holder assy. In this operation, engage the lock lever spring R on the lock lever R as shown at "E" in the figure below, then turn the lock lever R until hook C fits the cut-out A.

7. Put the interference board, set button L, and lock lever spring L onto the lock lever shaft. Pass the shaft through the hole in the left side of the roller holder assy.
8. Insert the lock lever shaft in the semicircular hole in lock lever R. Insert hook B of lock lever L from the position of cut-out A as with lock lever R, and turn to fasten in position.
9. Fasten the lock lever springs L/R inside the lock levers L/R.
10. Fasten the left and right side covers L/R to the roller holder by engaging the individual two hooks A to it.

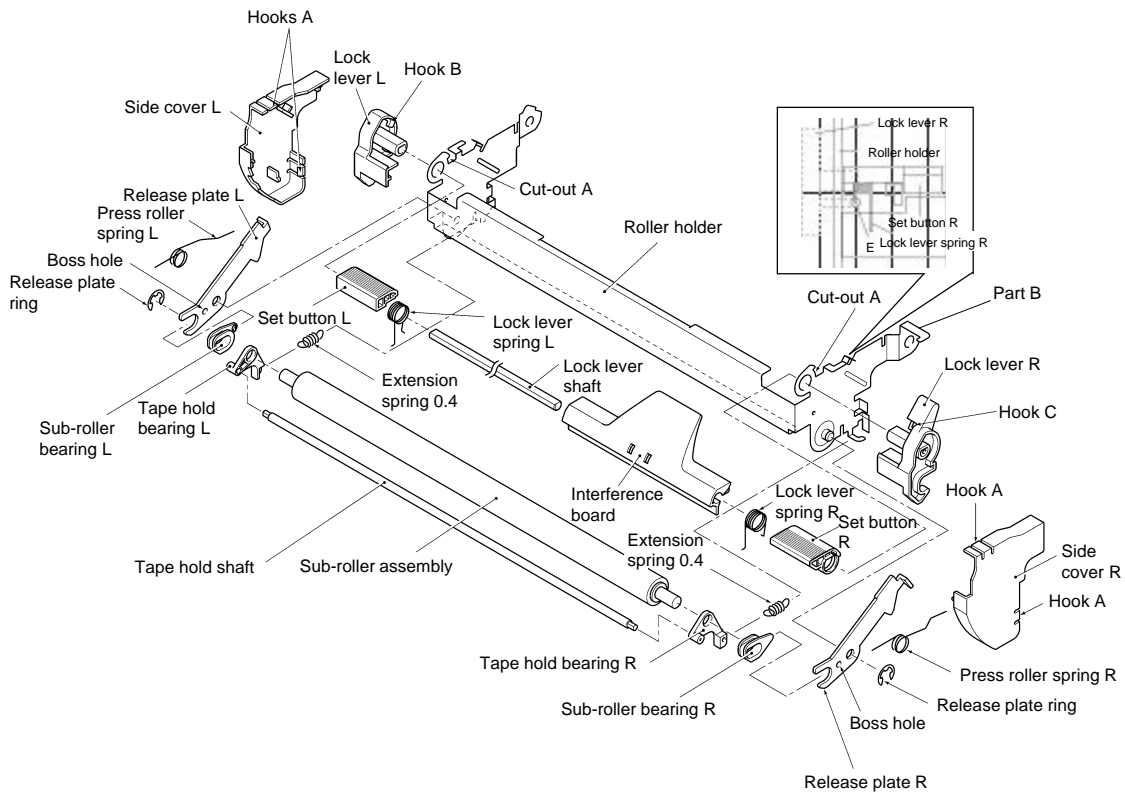

Fig. 4-12-1 Reassembling the Roller Holder Assy

4.12.2 Installing the Roller Holder Assy

1. Move the Y-cutter arm L as far as possible to the left.
2. Insert the chassis unit R boss shaft into the hole in the roller holder assy, then insert the chassis unit L boss shaft. Attach the roller holder rings to the left and right boss shafts to fasten the roller holder assy in position.
3. Lift up the roller holder assy and attach the roller holder spring.

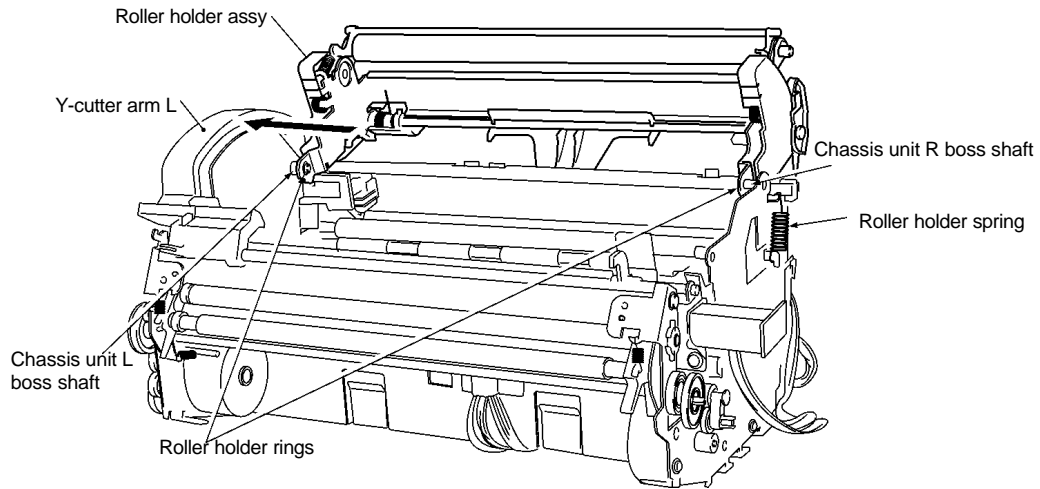

Fig. 4.12-2 Installing the Roller Holder Assy

4.13 Y-CA Chassis

4.13.1 Reassembling the Y-CA Chassis Assy

1. Attach the Y-CA motor with the two Y-CA motor screws.
2. Put the Y-CA driving pulley on the Y-CA chassis shaft and fasten it with the Y-CA driving pulley ring.
3. Insert the shaft of the Y-CA idle pulley into slot A of the Y-CA pulley holder. Push the Y-CA idle pulley in the direction of arrow A to fasten it in position.
4. Insert lug A of the Y-CA pulley holder into slot B in the Y-CA chassis. Push the Y-CA idle pulley holder in the direction of arrow A to fasten it in position.
5. Push the Y-CA pulley holder in the direction of arrow A and put the Y-CA timing belt over the Y-CA idle pulley. Put the timing belt over the Y-CA driving pulley.
6. Slide the Y-CA pulley holder in the direction of arrow B to tension the Y-CA timing belt and tighten the Y-CA pulley holder screw. Y-CA Adjust the timing belt tension to 0.784 to 1.37 N.m

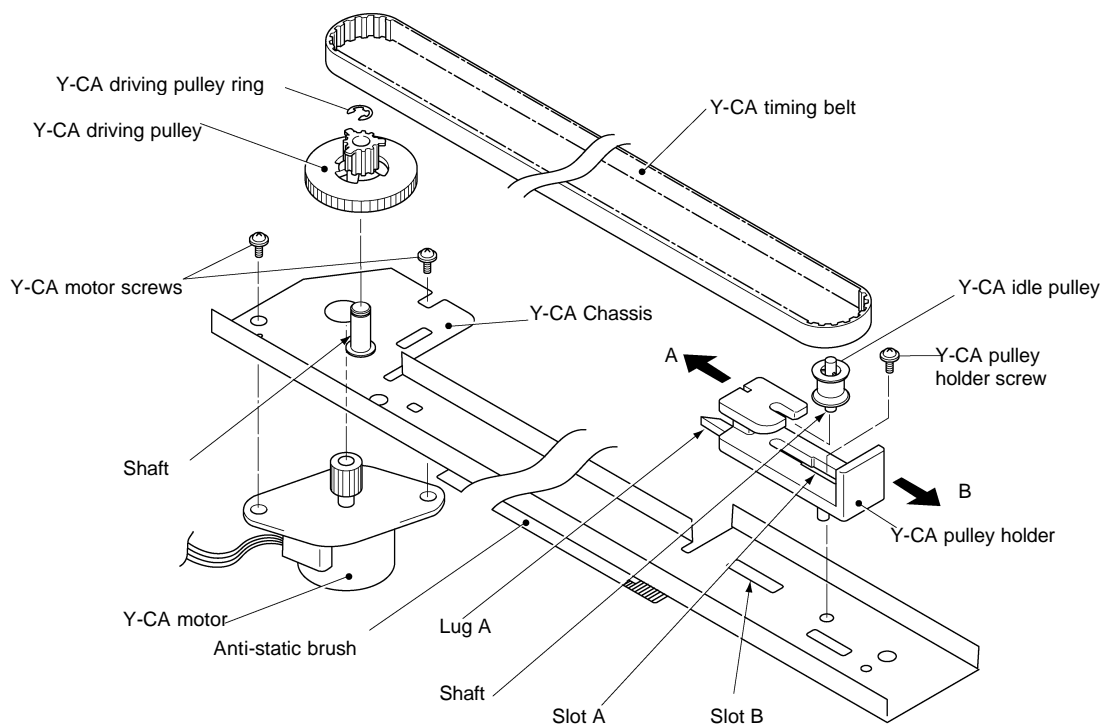

Fig. 4.13-1 Reassembling the Y-CA Chassis Assy

4.13.2 Installing the Y-CA Chassis Assy

1. Align the Y-CA chassis assy with the positioning hook and the two bosses on chassis L.

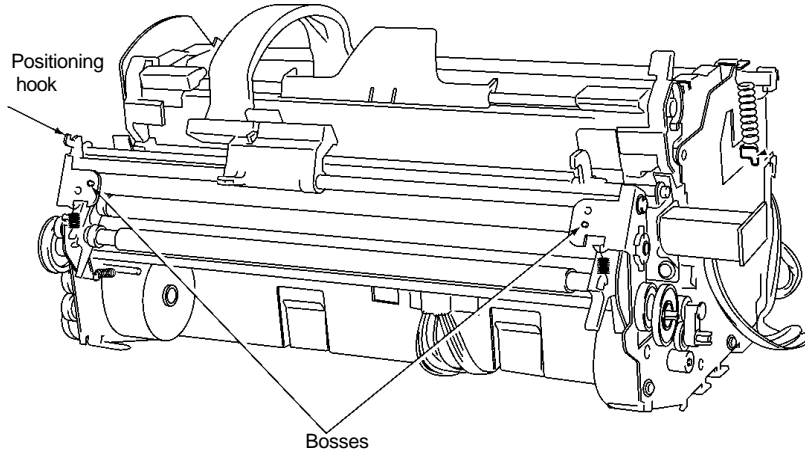

Fig. 4.13-2 Installing the Y-CA Chassis Assy (1)

2. Attach the Y-CA timing belt to the attachment position on the Y-cutter arm L.
3. Fasten the Y-CA unit with the two Y-CA frame screws.
4. Attach the Y-extension spring L.

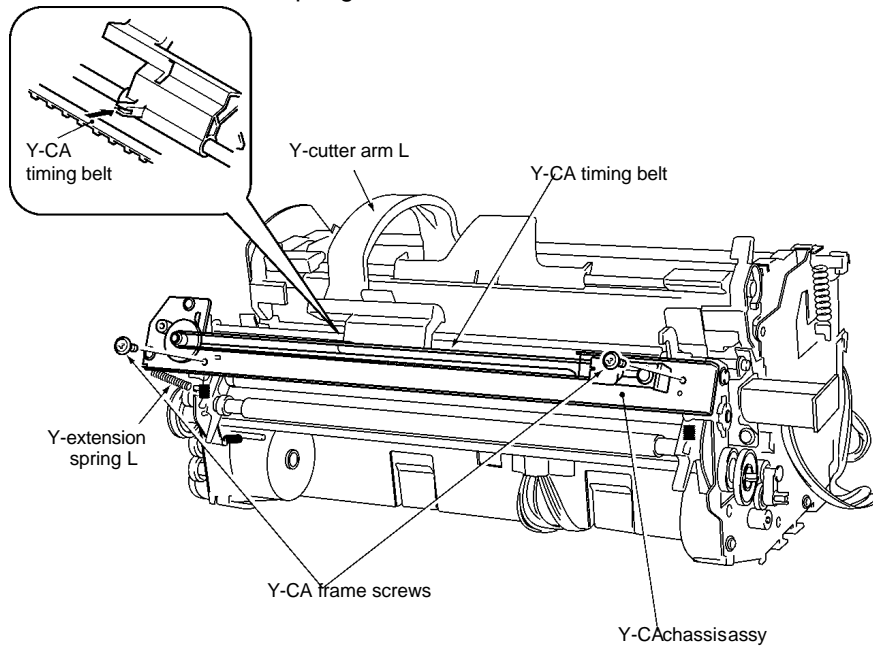

Fig. 4.13-3 Installing the Y-CA Chassis Assy (2)

4.14 T-Chassis

4.14.1 Reassembling the T-Chassis Unit

1. Install the T-idle gear and T-gear 35-14 on the T-chassis. Put the T-cam shaft through the T-cam gear and engage the hook on the T-cam gear with the groove on the T-cam shaft.
2. Align the T-sensor lever with boss hole A. Insert lug A through the slot and rotate in the direction of the arrow to fasten it in position.
3. Align the leaf switch TRG assy with boss hole B. Fasten the leaf switch TRG assy above the T-sensor lever with the leaf switch TRG screw.
4. Align the T-paper guide with the two boss holes C and fasten with the paper guide screw.
5. Insert the T-cutter upper assy into the T-cutter holder and fasten it with the T-cutter stopper.
6. Align the lug at each side of the T-cutter holder with the grooves in the T-paper guide. Install the T-cutter upper assy with the blade facing down.
7. Push the switch lever until it engages with the shaft hook on the T-paper guide.
8. Align the leaf switch TRI assy with boss hole D and fasten it in position with the leaf switch TRI screw.
9. Attach the T-push spring and T-cam roller to T-lever 2. Assemble T-lever 2 to T-lever 1 to form the T-lever unit.
10. Pass the T-lever shaft through the holes in the T-chassis and the T-lever unit. Open the T-paper guide hook and engage it with the groove in the T-lever shaft to install the T-lever unit.

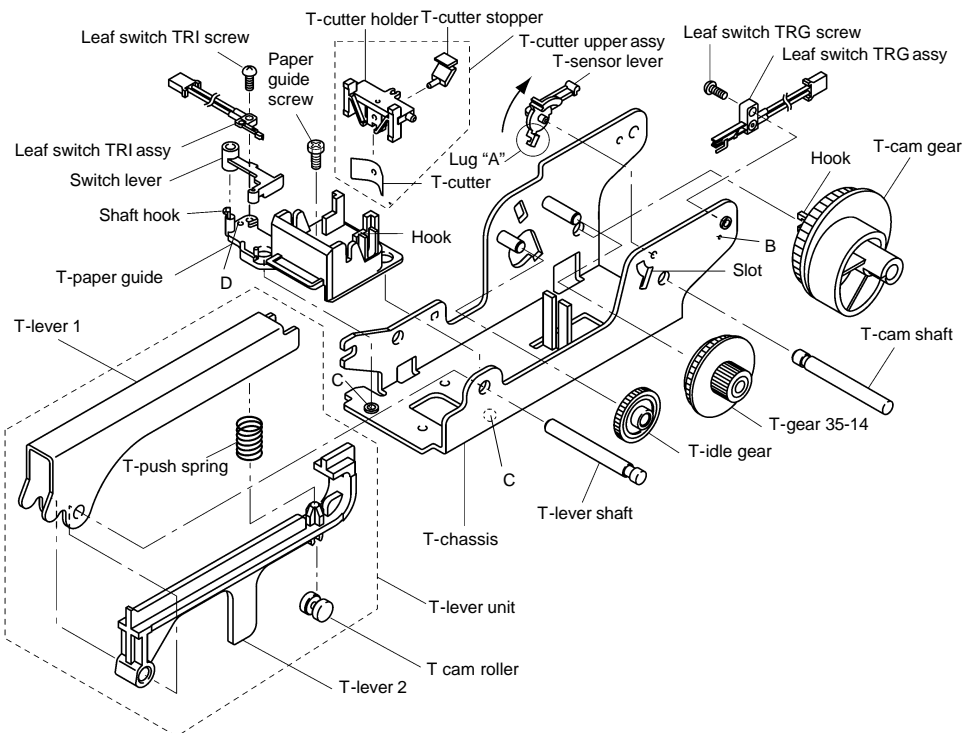

Fig. 4.14-1 Reassembling the T-Chassis Unit

4.14.2 Installing the T-Chassis Unit

1. Align the T-chassis unit with the two bosses.

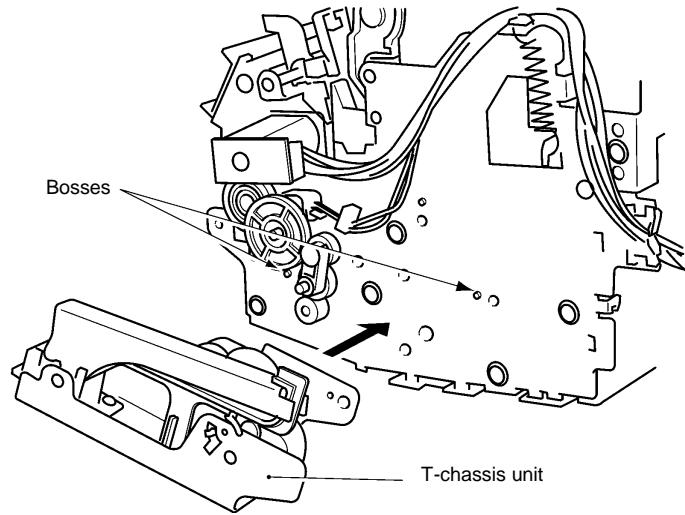

Fig. 4.14-2 Installing the T-Chassis (1)

2. Fasten the T-chassis unit with the two T-chassis screws.

3. Align the plate spring with the boss and fasten it with the plate spring screw, such that it holds T-gear 35-14 in position.

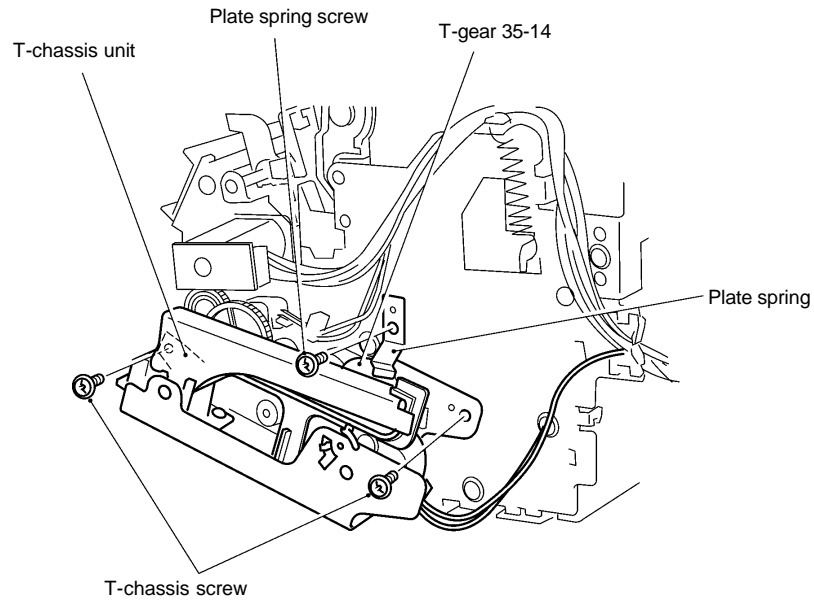
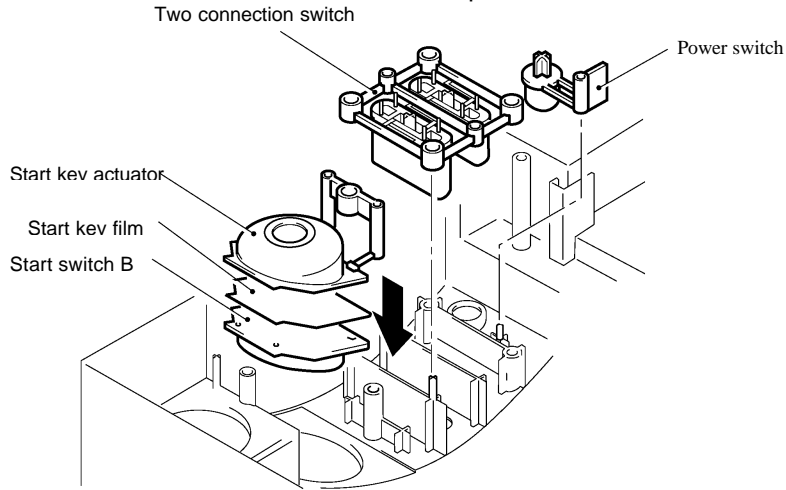

Fig. 4.14-3 Installing the T-Chassis Unit (2)

4.15 PCBs

4.15.1 .Installing the Switch PCB Assy

1. Turn the body cover upside-down, and attach the start switch B, start key film, start key actuator, two-connection switch, and power switch.



ig. 4.15-1 Installing the Switch PCB Assy (1)

2. Align the switch PCB assy 1 with the two bosses. Fasten it in position with the two switch PCB screws A and three switch PCB screws B.

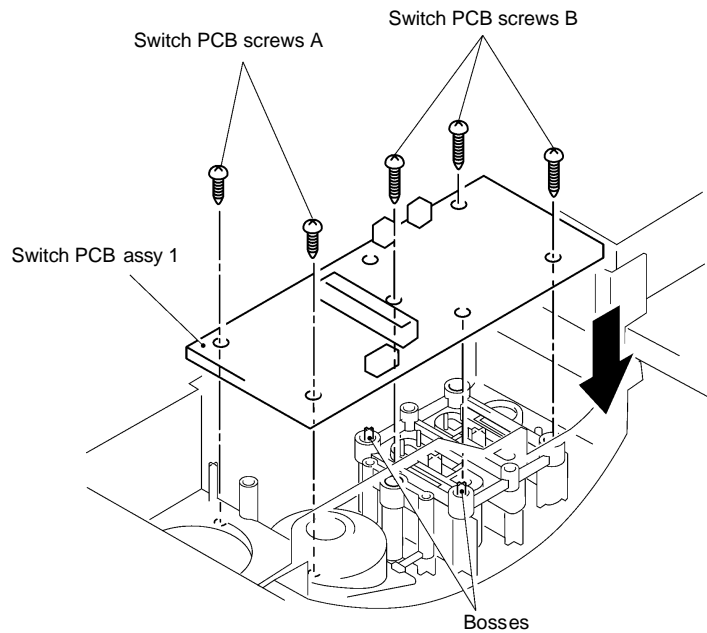

Fig. 4.15-2 Installing the Switch PCB Assy (2)

4.15.2 Installing the Jack PCB Assy

Align the jack PCB assy 1 with the boss and fasten it in position with the jack PCB screw.

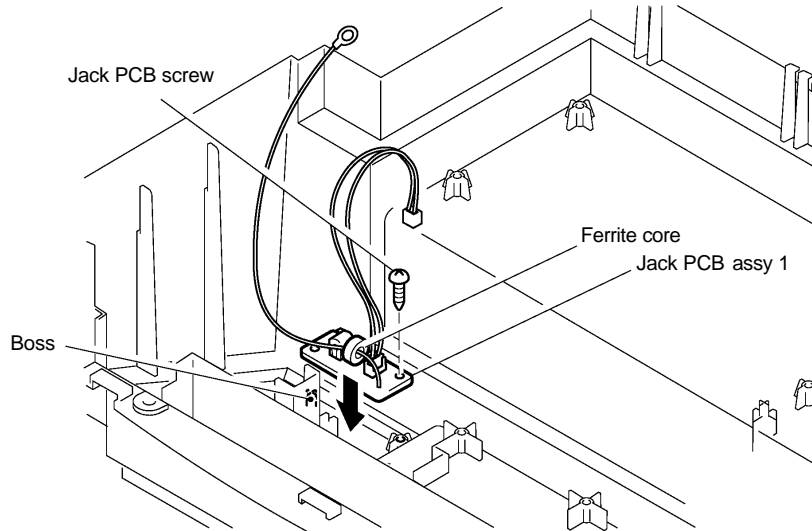

Fig. 4.15-3 Installing the Jack PCB Assy

4.15.3 Installing the Main PCB Assy

1. Align the Main PCB assy 1 with the two bosses and fasten it in position with the four main PCB screws.

2. Attach the power harness assy (red/black CN13) to the Main PCB assy 1.

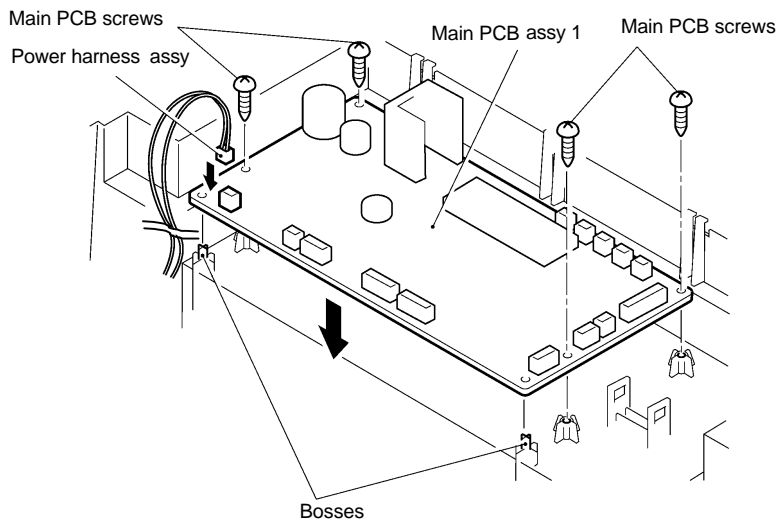

Fig. 4.15-4 Installing the Main PCB Assy

4.16 Chassis

4.16.1 Installing the Chassis Unit

1. Align the chassis unit with the two bosses on the bottom cover and fasten it in position with the four cassette holder screws.

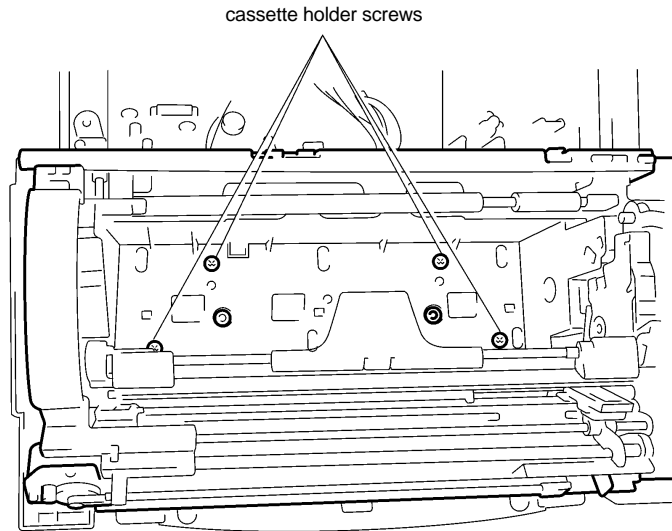

Fig. 4.16-1 Installing the Chassis Unit (1)

2. Attach the chassis unit using the two bottom cover screws B and the spring washers in the bottom cover.

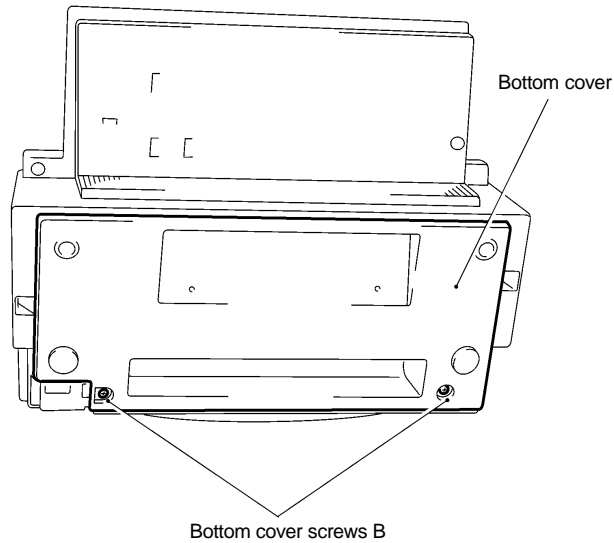

Fig. 4.16-2 Installing the Chassis Unit (2)

3. Remove the sensor frame screw from the sensor frame. Attach the ground wire and fasten it with the sensor frame screw.

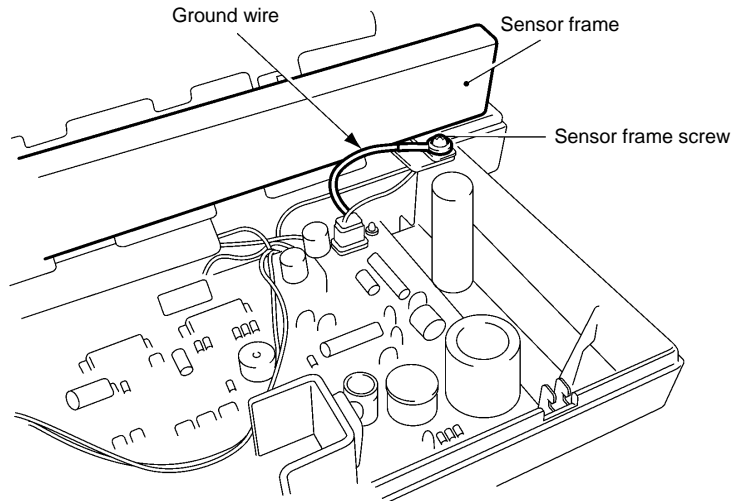

Fig. 4.16-3 Installing the Chassis Unit (3)

4.16.2 Installing the PE Sensor Unit

1. Engage the tip of the PE sensor unit with the paper sensor crank. Attach the PE sensor unit to the paper feed roller, such that the sensor is located vertically above the paper sensor crank. Take care not to damage the tip of the PE sensor unit during installation.
2. Open the bottom cover bearing supports outward and mount the PE sensor unit in the bearing supports.

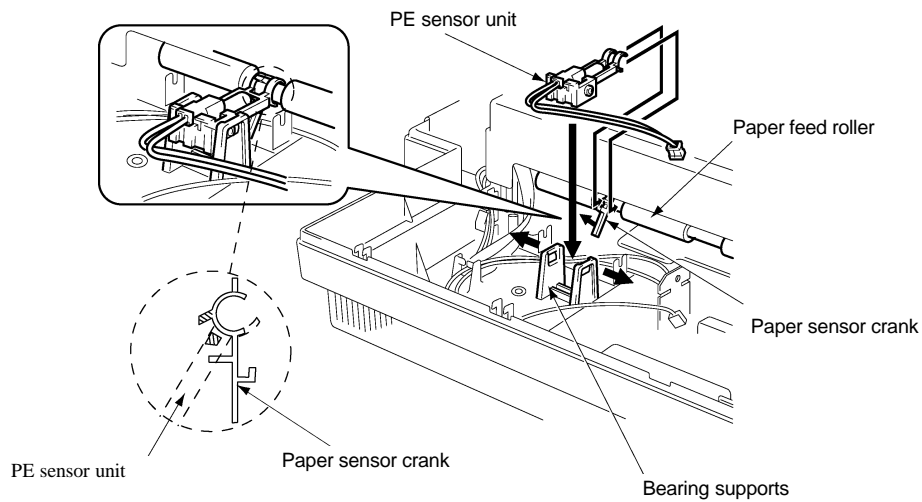

Fig. 4.16-4 Installing the PE Sensor Unit

4.16.3 Installing the Harness Connectors

Attach the 12 harness connectors to the MAIN PCB. Do not attach the power harness assembly (red/ black CN13).

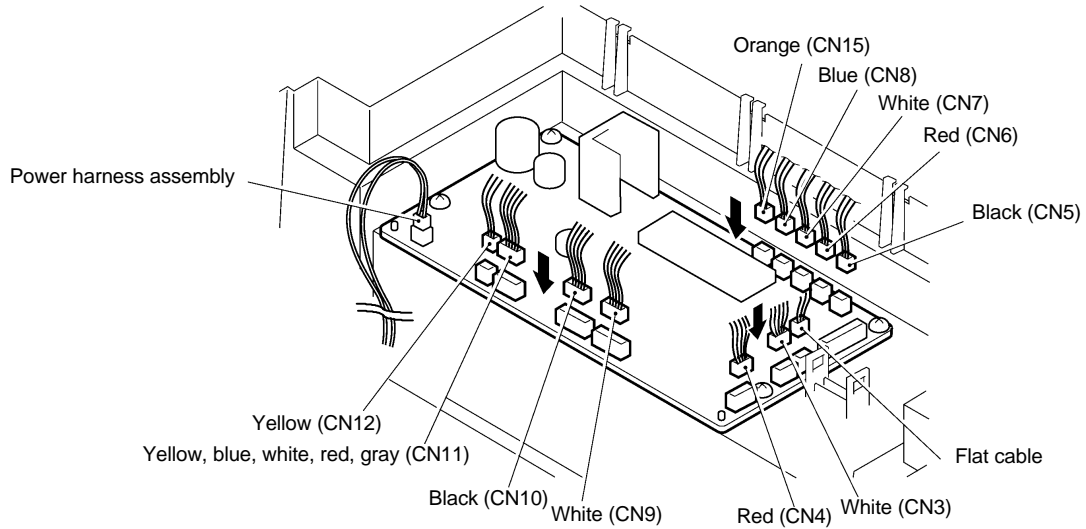

Fig. 4.16-5 Installing the Harness Connectors

4.17 Covers

4.17.1 Reassembling the Dial Switch Holder Assy B

1. Put the dial lock arm on the dial S holder assy shaft. Engage lug A with the dial S holder assy.

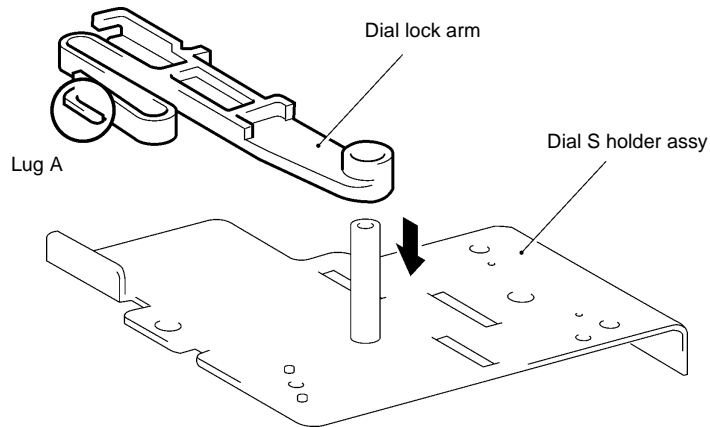

Fig. 4.17-1 Reassembling the Dial Switch Holder Assy B (1)

2. Align slide plate 2 with the boss on slide plate 1B and fasten it with the slide plate screw.

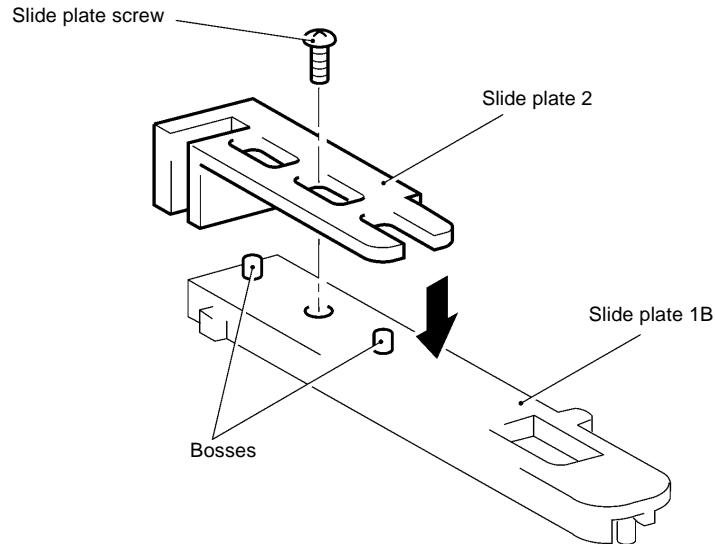

Fig. 4.17-2 Reassembling the Dial Switch Holder Assy B (2)

3. Engage the slide plate 1B hook and bosses A with the slots in the dial S holder assy. Ensure that slide plate 1B is positioned relative to the dial lock arm as shown in detail A.

4. Align the plate spring with bosses B and fasten it in position with the slide plate spring screw.

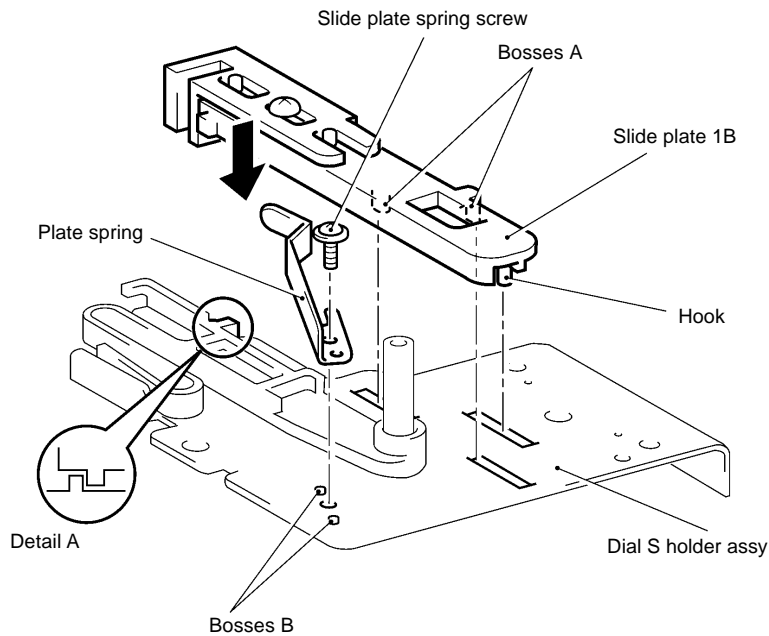

Fig. 4.17-3 Reassembling the Dial Switch Holder Assy B (3)

5. Align the leaf switch R assy (red CN2) and the leaf switch L assy (white CN3) with the boss holes and fasten them in position with the two leaf switch R/L screws.
6. Pull the plate spring in the direction of the arrow. Insert the dial switch B such that the indicator is positioned between the two leaf switches.

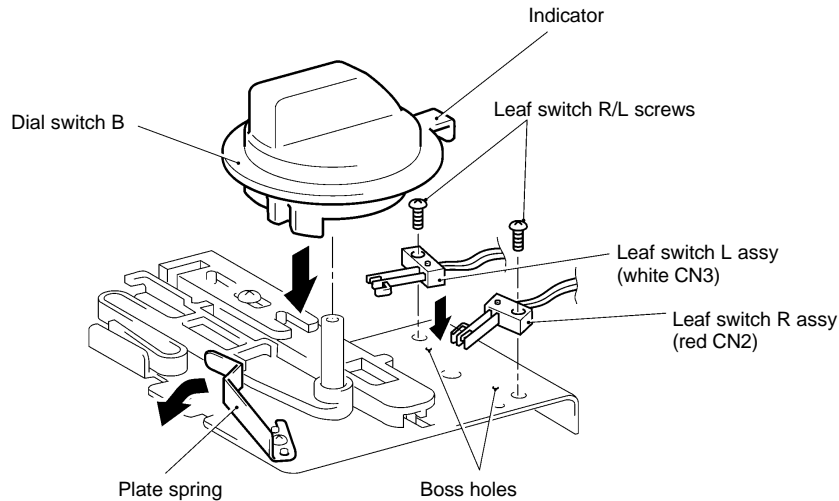

Fig. 4.17-4 Reassembling the Dial Switch Holder Assy B (4)

4.17.2 Installing the Dial Switch Holder Assy B

1. Align the dial switch holder assy with the boss under the body cover and fasten it in position with the two dial holder screws.
2. Attach the leaf switch R assy (red CN2) and leaf switch L assy (white CN3) harness connectors to the switch PCB.
3. Install the switch harness assy (CN1) to the switch PCB.
4. Attach the dial lock arm spring between the dial lock arm and the lug on the body cover.

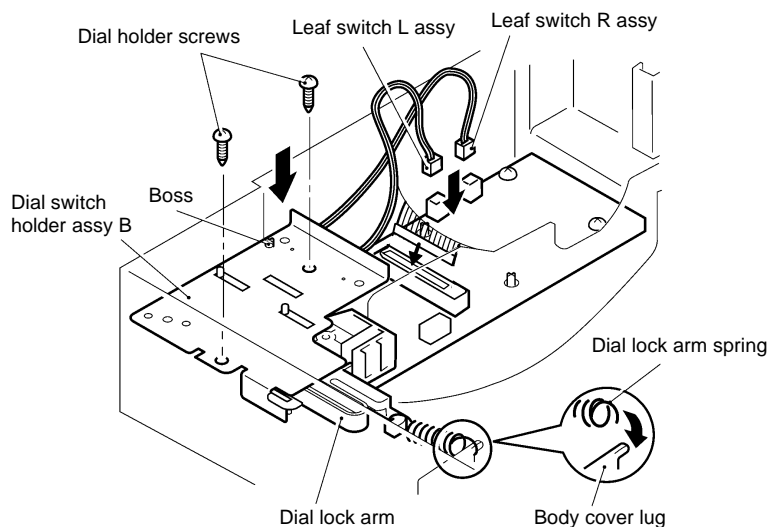

Fig. 4.17-5 Installing the Dial Switch Holder Assy B

4.17.3 Installing the Cover Switch Assy

1. Align the cover switch assy with the boss hole and fasten it in position with the cover switch screw.
2. Connect the cover switch unit harness connector (yellow CN4) to the switch PCB.

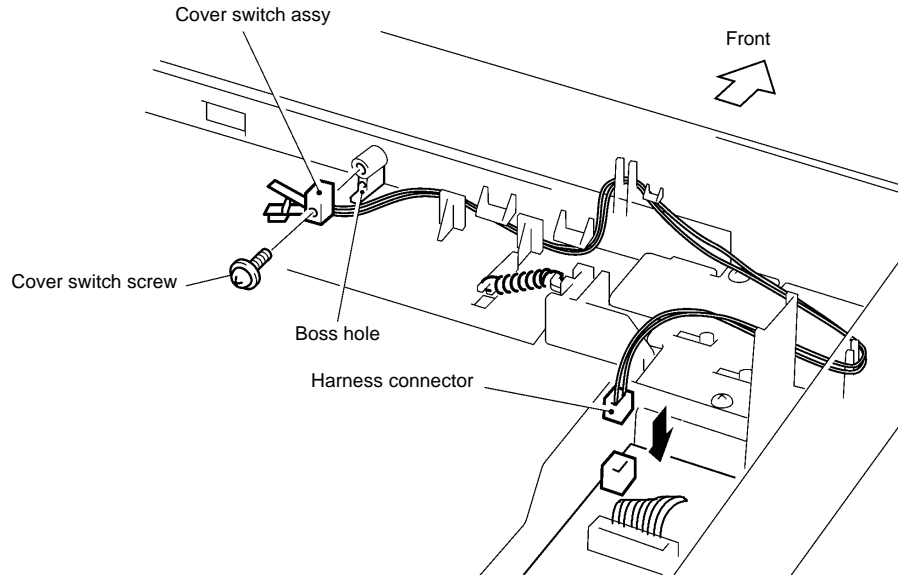

Fig. 4.17-6 Installing the Cover Switch Assy

4.17.4 Installing the Front Cover

1. Align the front cover with the angle of the cover front face and insert parts A into parts B. Push until the hooks at each side of the front cover engage.

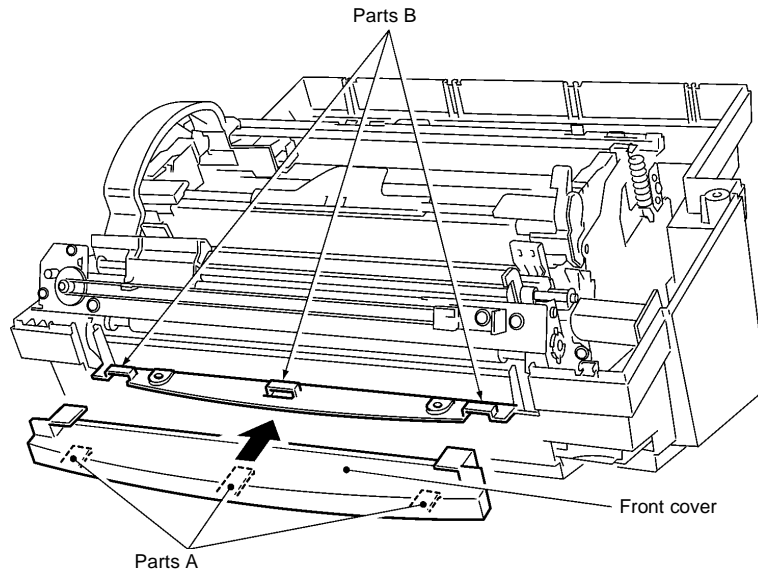

Fig. 4.17-7 Installing the Front Cover (1)

2. Fasten the two front cover screws under the bottom cover.

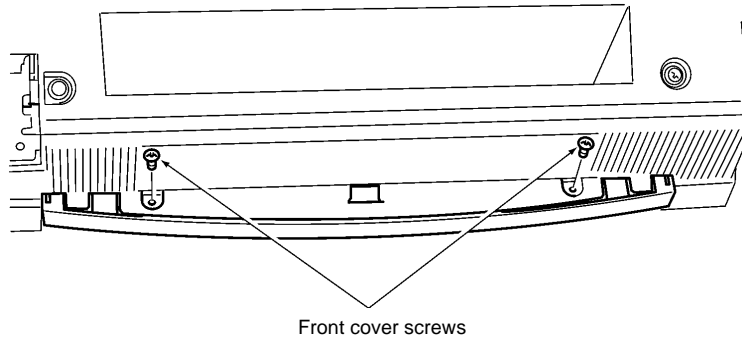

Fig. 4.17-8 Installing the Front Cover (2)

4.17.5 Installing the Body Cover

1. Pass all the harnesses through the hooks in the bottom cover.

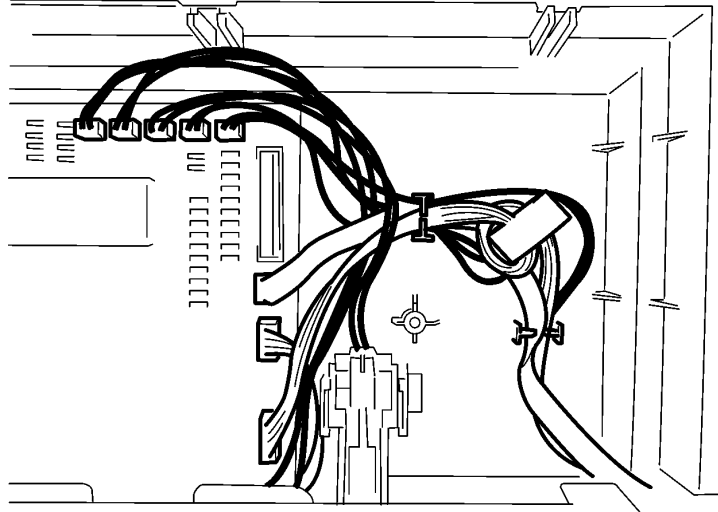

Fig. 4.17-9 Installing the Body Cover (1)

2. Connect the switch harness assy (white CN1) to the MAIN PCB.

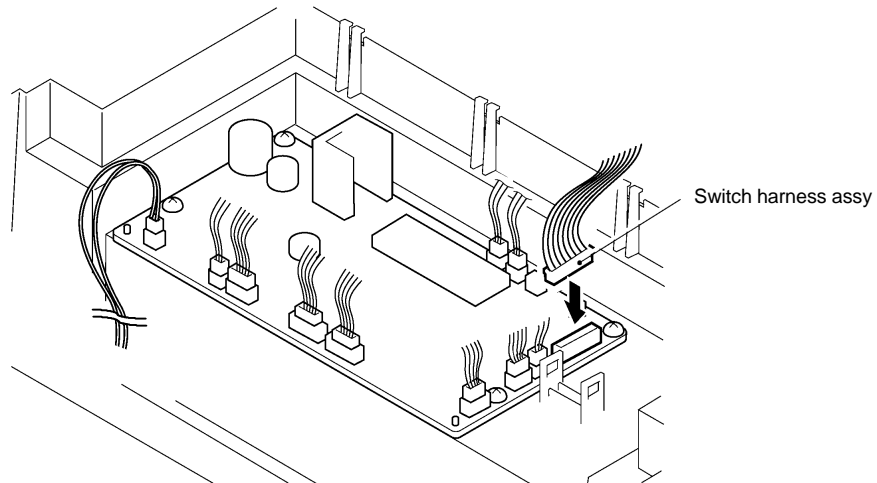

Fig. 4.17-10 Installing the Body Cover (2)

3. Insert the lug on the Y-cutter guide R into the slot in the dial switch holder assy.

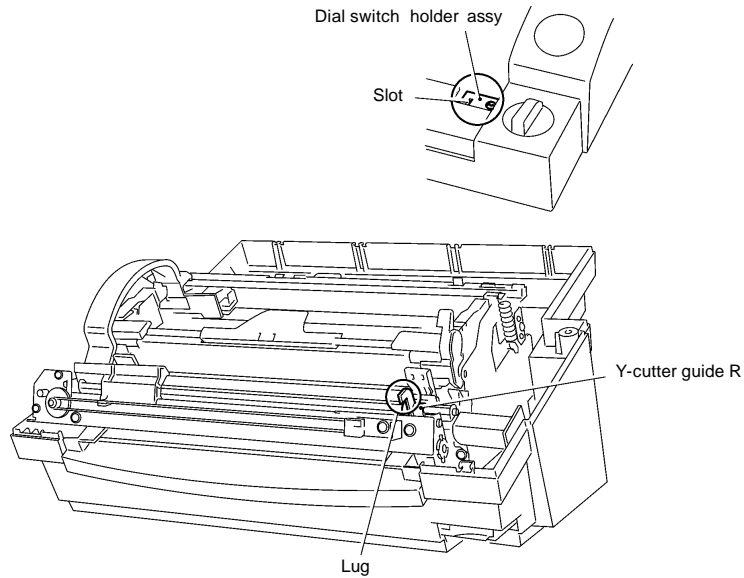

Fig. 4.17-11 Installing the Body Cover (3)

4. Engage the two hooks on the body cover front face.
5. Push down the body cover sides to engage the two hooks.
6. Push down the body cover rear face to engage the four hooks.

⊗ Hook

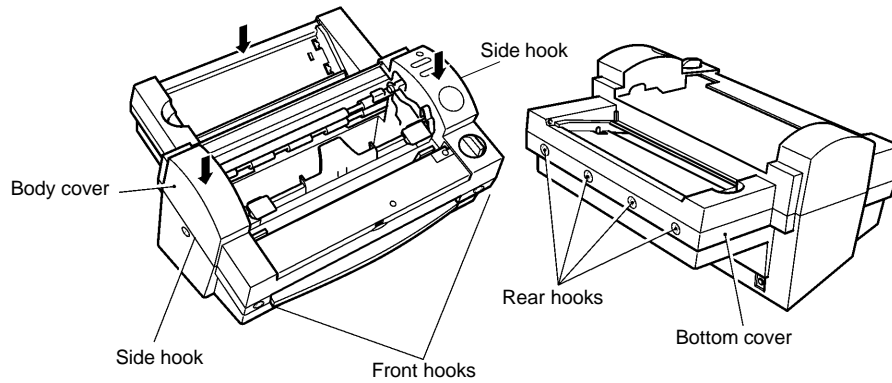

Fig. 4.17-12 Installing the Body Cover (4)

7. Insert the two bottom cover screws A from underneath to fasten the body cover in position.

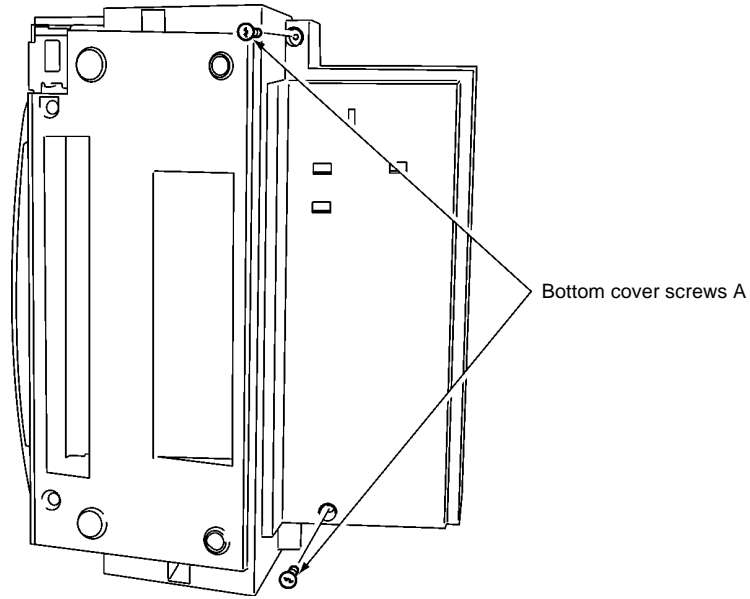

Fig. 4.17-13 Installing the Body Cover (5)

4.17.6 Installing the Paper Tray and Paper Guide

1. Press the paper guide hook (at the rear of the paper tray) into the groove in the paper tray.

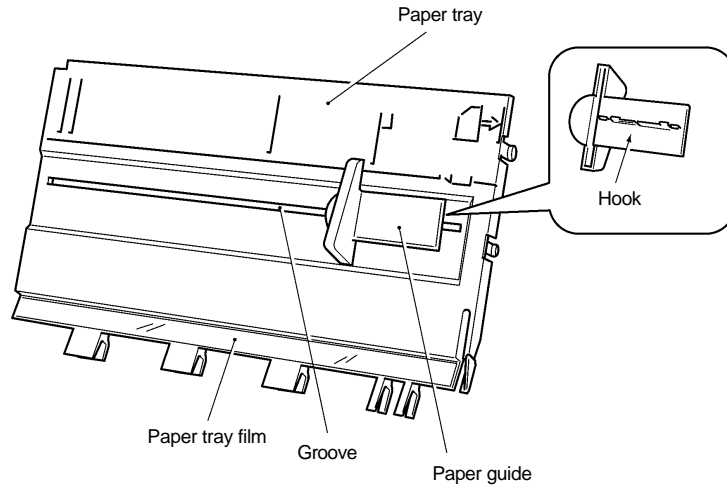

Fig. 4.17-14 Installing the Paper Guide

2. Push the paper tray in the direction of arrow A until its edge reaches the paper feed roller. Press the top of the paper tray in the direction of arrow B to fasten it in position.

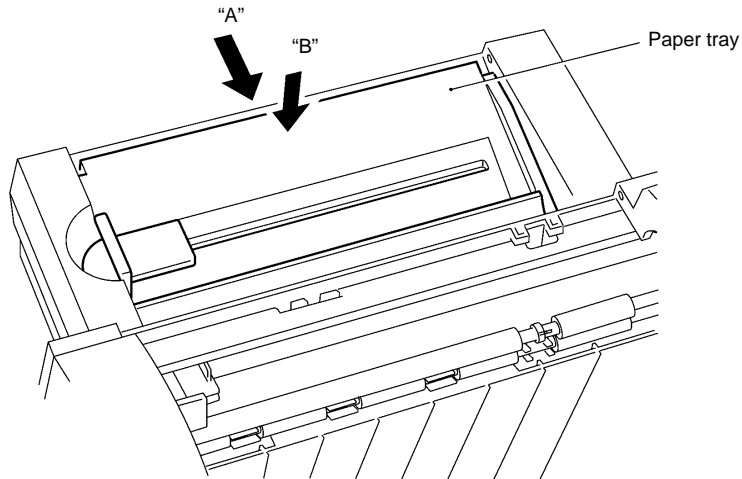

Fig. 4.17-15 Installing the Paper Tray

4.17.7 Installing the Sub-tray

Flex the center of the sub-tray toward you to insert the shafts into the shaft recesses in the body cover. The sub-tray can be folded in the direction of the arrow.

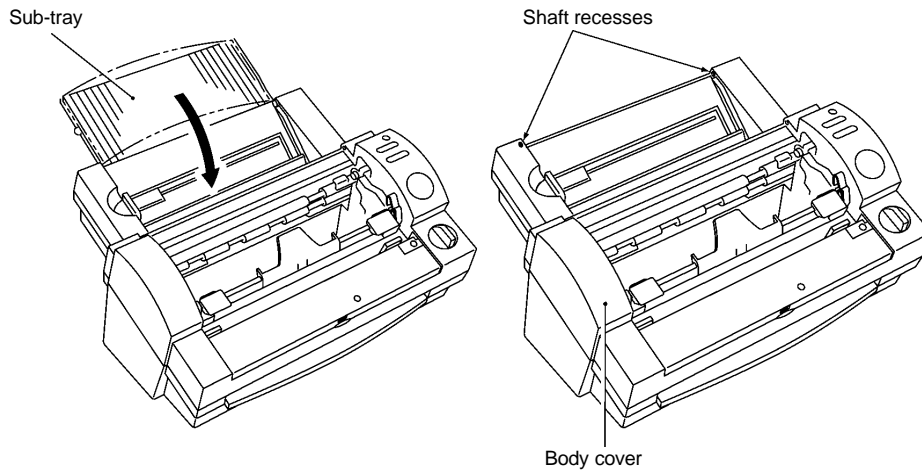

Fig. 4.17-16 Installing the Sub-tray

4.17.8 Installing the Top Cover

With the top cover in the open position, insert the shafts into the shaft recesses in the body cover to mount the cover.

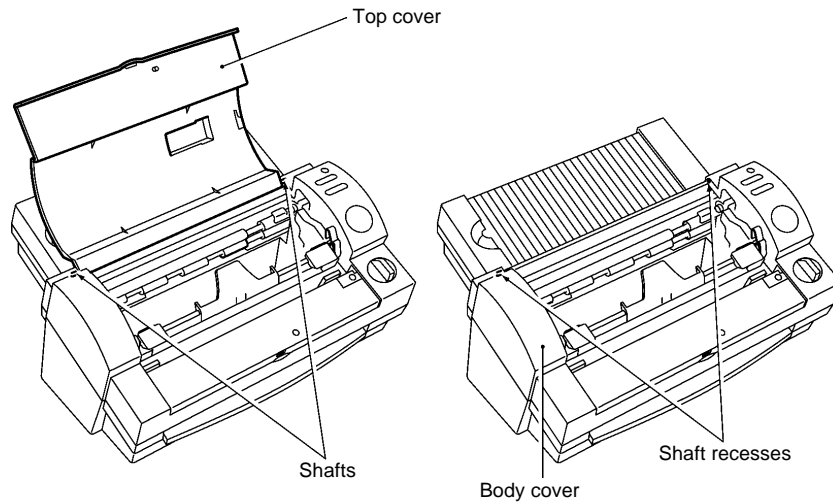

Fig. 4.17-17 Installing the Top Cover

4.17.9 Installing the Trimmer Upper Cover

1. Set the unit on its side with the trimmer upper cover uppermost.
2. Engage part B of the trimmer upper cover with part A on the chassis. Align the trimmer cover with the two bosses and fasten it in position with the two trimmer cover screws.

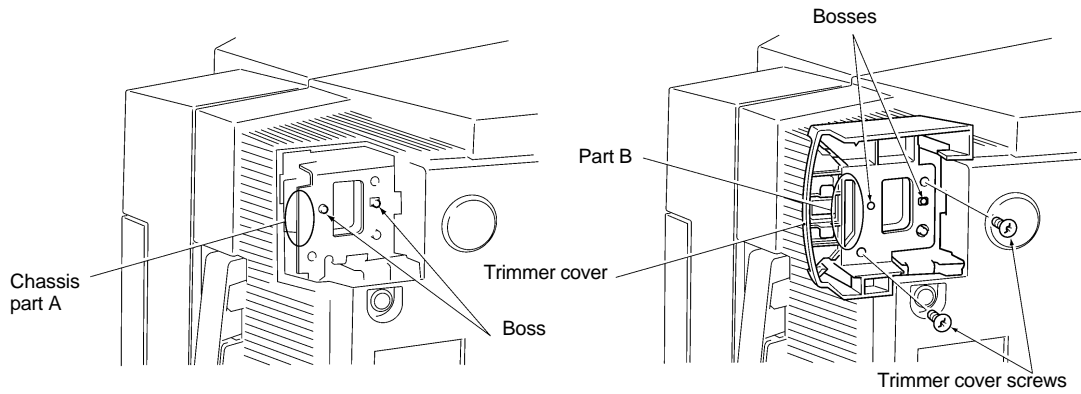

Fig. 4.17-18 Installing the Trimmer Cover 1

3. Insert the T-cutter plate into the trimmer cover.
4. Insert the trimmer bottom cover.

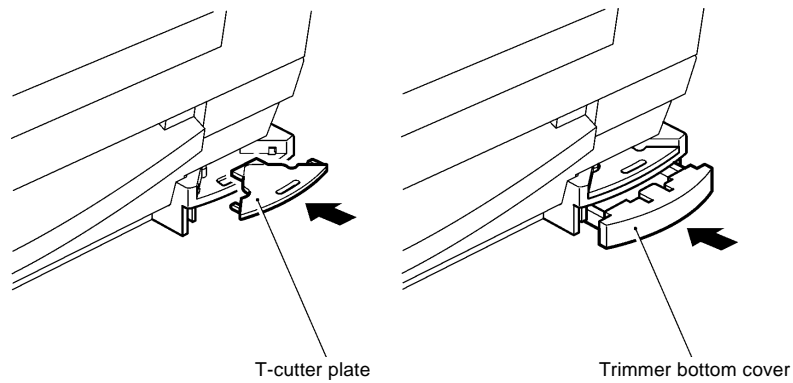

Fig. 4.17-19 Installing the Trimmer Cover 2

4.18 Installing the Film Cartridge

1. Insert the film cartridge with the arrow mark facing forward. Lower it into the roller holder assembly.

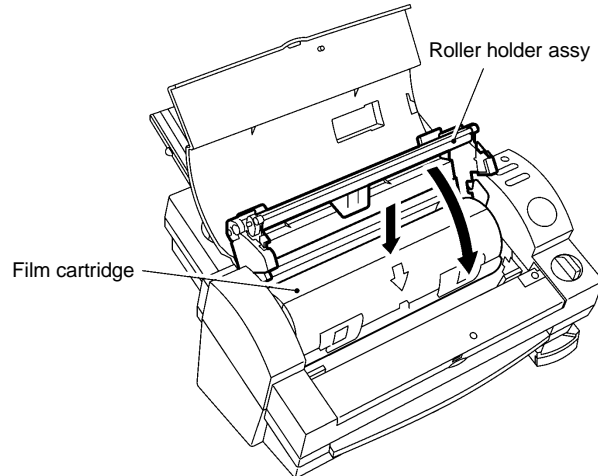

Fig. 4.18-1 Installing the Film Cartridge (1)

2. Push the left and right set buttons to lock the roller holder assembly in position. Close the top cover.

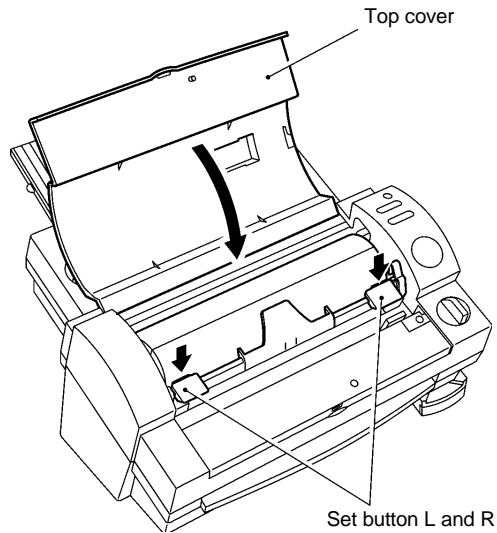

Fig. 4.18-2 Installing the Film Cartridge (2)

Note: See 6.2.1 Replacing the Cartridge in Chapter 6 Maintenance for details about changing the film cartridge.

Chapter 5.

ELECTRONIC CONTROLLERS

CONTENTS

Chapter 5. ELECTRONIC CONTROLLERS

5.1	Electronic Parts.....	5-1
5.1.1	Configuration of the Electronic Parts	5-1
5.1.2	Outline of the Electronic Parts	5-2
5.2	Operation of Each Part	5-3
5.3	Main PCB.....	5-4
5.4	Detector Circuits	5-9
5.5	Motor Drive Circuits	5-15
5.6	Power Supply Circuits.....	5-18

5.1 Electronic Parts

5.1.1 Configuration of the Electronic Parts

The electronic parts of the unit comprise the following PCBs and an AC adaptor.

- Main PCB
- Switch PCB
- Jack PCB
- Paper size sensor PCB
- Film detector PCB
- AC adaptor

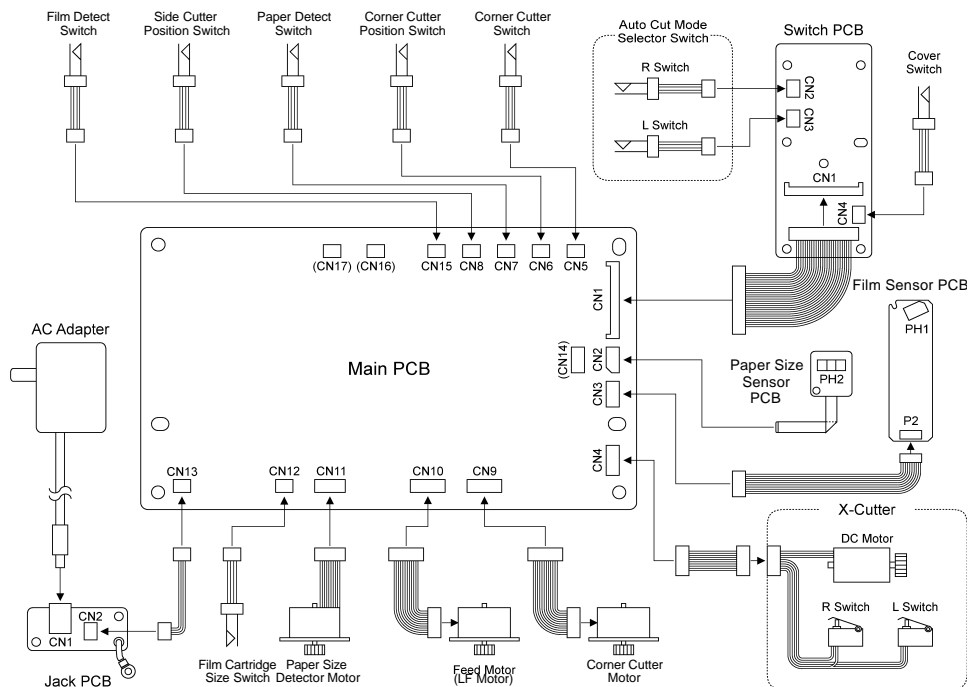

Fig. 5.1-1 Configuration of the Electronic Parts

5.1.2 Outline of the Electronic Parts

Each PCB and the AC adaptor are described below.

- Main PCB

The main PCB is located below the paper guide. It is connected to all PCBs, motors, switches, and cables.

It converts the unstabilized DC voltages input from the Jack PCB to stabilized +5V and +24V DC voltages, which are supplied to all controllers.

The Main PCB controls motors, LED indicators, and buzzers according to the signals input from the detector circuits on the Switch PCB, Paper size detector PCB, Film detector PCB, and on the Main PCB itself.

- Switch PCB

The Switch PCB is located at the rear of the body cover. It is connected by a cable to the Main PCB.

On the Switch PCB are mounted the Power switch, Cut button, Feed button, and Start button; the LED which lights the Start button; and connectors to connect to the cover and dial leaf switches.

- Jack PCB

The Jack PCB is located at the jack input at the rear of the bottom cover. It supplies unstabilized DC voltages from the AC adaptor to the Main PCB.

- Paper size sensor PCB

The Paper size sensor PCB is located on the Y-carriage. The sensors to detect the document width are mounted on this PCB.

- Film sensor PCB

The Film sensor PCB is located on the side of the film cartridge holder. The sensors to detect the film type are mounted on this PCB.

- AC adaptor

The AC adaptor converts the input AC voltage to an unstabilized DC voltage. The AC adaptor jack is connected to the Jack PCB connector.

5.2 Operation of Each Part

This unit is operated by three 24 V stepping motors and one DC motor (for the X-cutter unit). The operation of each motor shown in Fig. 5.1-1 is described below.

- Paper feed motor (LF Motor)

This motor is used to feed the document and film and to eject the laminated document.

The motor is a 42 mm dia. 48-step PM stepping motor. It is set to feed the document and tape approximately 1 mm per 16 steps using 2-2 phase drive.
- Trimming motor (TC Motor)

This motor conducts trimming operation and drives the Y-cutter vertical movement.

The motor is a 42 mm dia. 48-step PM stepping motor. 480 steps complete one trimming operation. When the direction of motor rotation is reversed, 250 steps complete the Y-cutter up and down movements.
- Y-CA motor

This motor moves the Y-carriage to the edge of the document. The Y-cutter and paper size sensor PCB are mounted on the Y-carriage. The motor is a 42 mm dia. 24-step PM stepping motor. It is set to feed the Y-carriage approximately 1 mm per 5 steps using 2-2 phase drive.
- X-cutter (DC motor)

This 24V DC motor and two cutter position detector switches are mounted on the X-cutter. The direction of cutter movement is determined by the direction of current flow in the DC motor.

5.3 Main PCB

Fig. 5.3-1 shows a block diagram of the electrical parts.

The Main PCB comprises the CPU, detector circuits (including switch status detection), motor drive circuits, and power circuits.

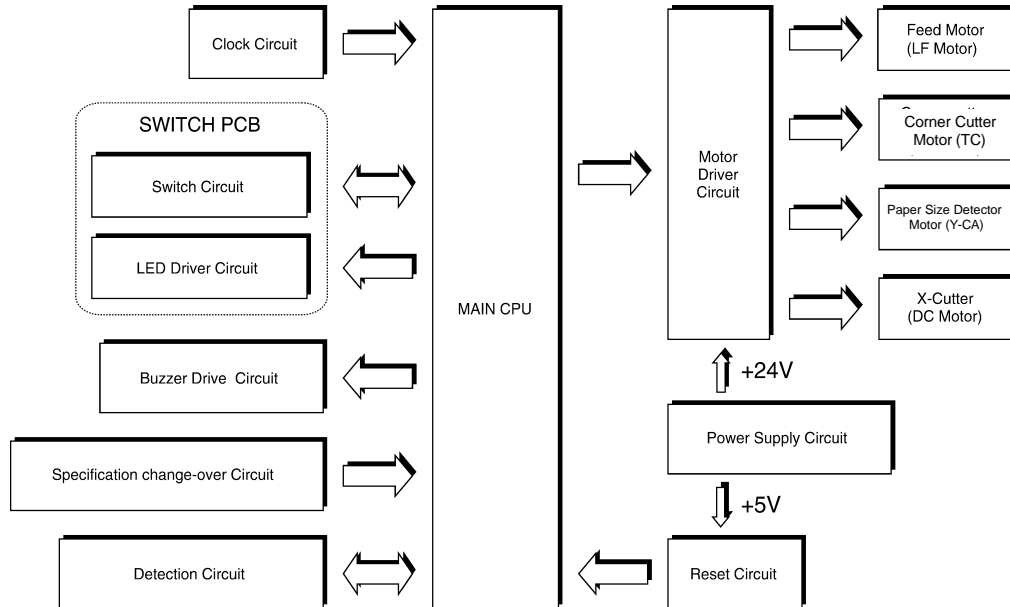

Fig. 5.3-1 Block Diagram of the Electrical Parts

- **Main CPU**

The main CPU is an 8-bit CMOS microcontroller that controls the overall system.

The main CPU incorporates 256 kB RAM, 8 kB ROM, and 56 I/O ports.

The I/O map for the I/O ports is shown in Table 5.3-1 overleaf.

Table 5.3-1 CPU I/O Map

Port	Pin No.	I/O	
P07	16	IN	S3
P06	15	IN	S2
P05	14	IN	S1
P04	13	IN	S0
P03	12	OUT	YA MOTOR PHASE A
P02	11	OUT	YA MOTOR PHASE B
P01	10	OUT	YA MOTOR PHASE C
P00	9	OUT	YA MOTOR PHASE D
P17	24	OUT	DC-IN1
P16	23	OUT	DC-IN2
P15	22	OUT	DC-ENA
P14	21	OUT	DC-IL
DVO (P13)	20	OUT	BUZZER
P12	19	IN	ENC
INT1 (P11)	18	IN	INT (COVER)
P10	17	IN	COVER
P22	28	IN	S8
P21	27	IN	S7
P20	25	IN	S6
P37	40	OUT	KO0
P36	39	OUT	KO1
P35	38	OUT	LED 4
P34	37	OUT	LED 1
P33	36	OUT	LED 2
P32	35	OUT	LED 3
P31	34	OUT	YCA-LED
P30	33	OUT	ENC-LED
P47	48	IN	ON/OFF-R
P46	47	IN	Y-G
P45	46	IN	P-END
P44	45	IN	TR-G
P43	44	IN	KI3
P42	43	IN	KI2
P41	42	IN	KI1
P40	41	IN	KI0
P54	53	IN	X-CUT2
P53	52	IN	X-CUT1
P52	51	IN	ON/OFF-L
P51	50	IN	S4
P50	49	IN	S5
P67	63	IN	ACVL
P66	62	IN	ACVH
P65	61	OUT	YA MOTOR HIGH VOLT
P64	60	IN	CSEL B
P63	59	IN	YCA-F
P62	58	IN	Csize

Port	Pin No.	I/O	
P61	57	IN	CSEL A
P60	56	IN	TPS
P77	8	OUT	T/C MOTOR PHASE B
P76	7	OUT	T/C MOTOR PHASE A
P75	6	OUT	T/C MOTOR PHASE D
P74	5	OUT	T/C MOTOR PHASE C
P73	4	OUT	LF MOTOR PHASE B
P72	3	OUT	LF MOTOR PHASE A
P71	2	OUT	LF MOTOR PHASE D
P70	1	OUT	LF MOTOR PHASE C

- Clock Circuit

The main CPU incorporates a clock-generation circuit which uses externally mounted components. This circuit and the main CPU internal circuit generate an 8 MHz clock signal.

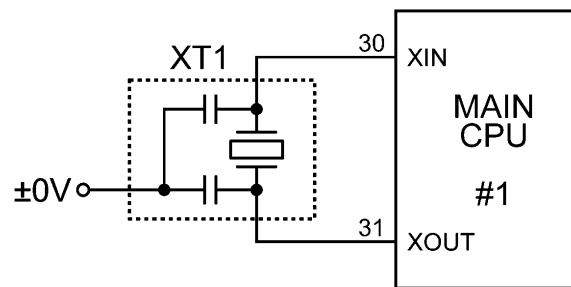

Fig. 5.3-2 Clock Circuit

- Reset Circuit

This circuit resets the main CPU when the power is turned ON or OFF. M51953 is used as the reset IC in this circuit.

When the power is turned ON, the reset IC holds the reset output Low for approximately 30 ms after the +5V DC power supply applied voltage reaches 4.25 V. After this period the reset output becomes High to clear the main CPU reset status.

When the power is turned OFF, after the +5V DC power supply applied voltage drops to 4.25 V, or below, the reset IC sets the reset output Low to reset the main CPU.

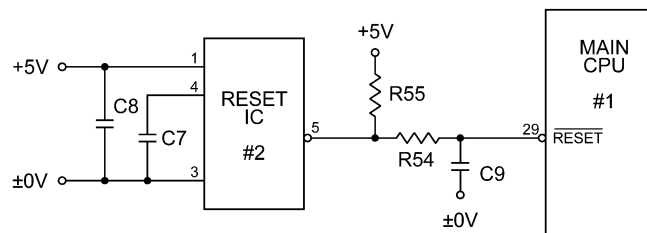

Fig. 5.3-3 Reset Circuit

- Buzzer Drive Circuit

This circuit sounds the piezoelectric buzzer.

To sound the buzzer, the main CPU outputs a 4 kHz squarewave with 50% duty from port DV0 (P13). This signal is used to generate the buzzer sound.

To stop the buzzer, the port status is set to High level using R82 in the input mode.

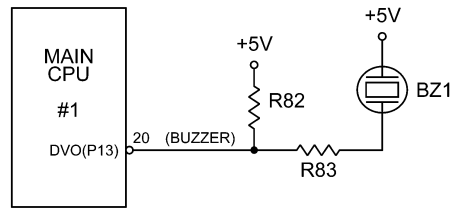

Fig. 5.3-4 Buzzer Drive Circuit

- LED Drive Circuit

This circuit drives the red and green LED indicators mounted on the switch LED and lights the Power button red, green, or orange.

The LEDs are directly driven by the high-current ports P32, P33, P34, and P35 of the main CPU. The LED lights when the corresponding output is Low.

When not lit, the LED is in the high-impedance status and the port level is indeterminate.

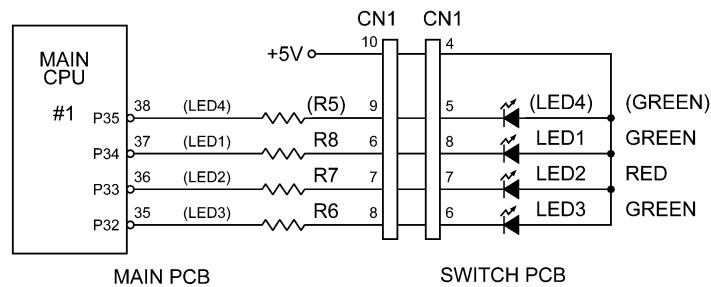

Fig. 5.3-5 LED Drive Circuit

- Specification Switching Circuit

This circuit reads the specification switching information.

The specification switching is conducted by a ROM program built into the main CPU according to the solder point settings on the PCB.

The relationships between the solder points and specifications are shown in PART LIST.

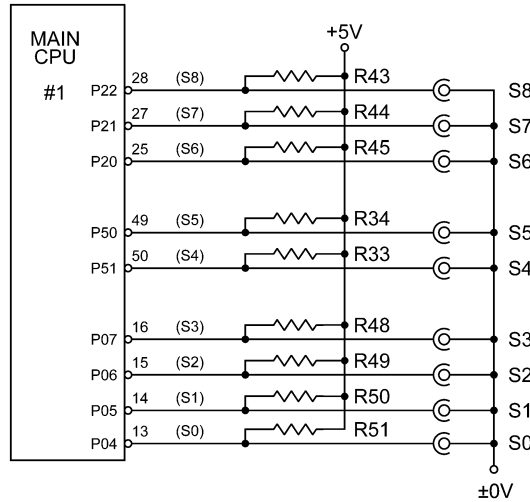

Fig. 5.3-6 Specification Switching Circuit

- Detector Circuits

These circuits detect the status of the switches and buttons that operate the unit (Power switch, Cut button, Feed button, Start button, and dial switches) and the sensors that determine the film type, document length and width, and cover open/closed status.

- Motor Drive Circuits

These circuits convert the motor control signals output from the main CPU output ports to 24 V drive signals and supplies these voltage signals to each motor.

- Power Supply Circuits

These circuits convert the unstabilized DC power supply input from the Jack PCB into a stabilized +5V DC power supply for the logic ICs, including the main CPU, and into a stabilized +24V DC power supply to drive the motors.

5.4 Detector Circuits

These circuits detect the status of the switches, keys and buttons that operate the machine (Power switch, Cut key, Feed key, Start/Stop button, and dial switches) and the sensors that determine the film type, document length and width, and cover open/closed status.

The circuits that detect each switch and sensor are listed below.

In addition, a separate switch to detect the motor initial status is also mounted.

- Switch scan circuit Power switch, Cut key, Feed key, Start/Stop button, and TRIMMING switch
- Dial switch circuit ON/OFF-R, ON/OFF-L switches
- Cover switch circuit Cover switch
- Paper width detector circuit YCA-F switch
- Paper length detector circuit P-END switch
- Cartridge type detector circuit CSIZE switch
- Film type detector circuit ENC sensor
- Film feed detector circuit TPS switch
- Input voltage detector circuit ACVL, ACVH signals

- Switch Scan Circuit

This circuit in the main CPU scans the status of the Power switch, Cut button, Feed button, Start button, and TRI switch (leaf switch) at 14 ms intervals to continuously detect the status of each switch.

The circuit comprises a matrix of two output ports (P36, P37) and four input ports (P40 to P43). A Low signal is output at 7 ms intervals from one of the two output ports and the switch status at that time is detected from the status of P40 to P43).

- When the main CPU detects that the Power switch was pressed, it turns the power ON if it was previously OFF, or it turns the power OFF if it was previously ON.
- When the main CPU detects that the Feed button was pressed, it starts the document and film feed operation. The document and tape are fed in approximately 0.5 mm intervals but the document and tape are fed continuously while the Feed button is held down.
- When the main CPU detects that the Cut button was pressed, it operates the X-cutter to start the film-cutting operation.
- When the main CPU detects that the TRI switch was pressed, it starts the trimming operation.
- When the main CPU detects that the Start button was pressed, it starts feeding and compressing the document in the selected automatic cutting mode.

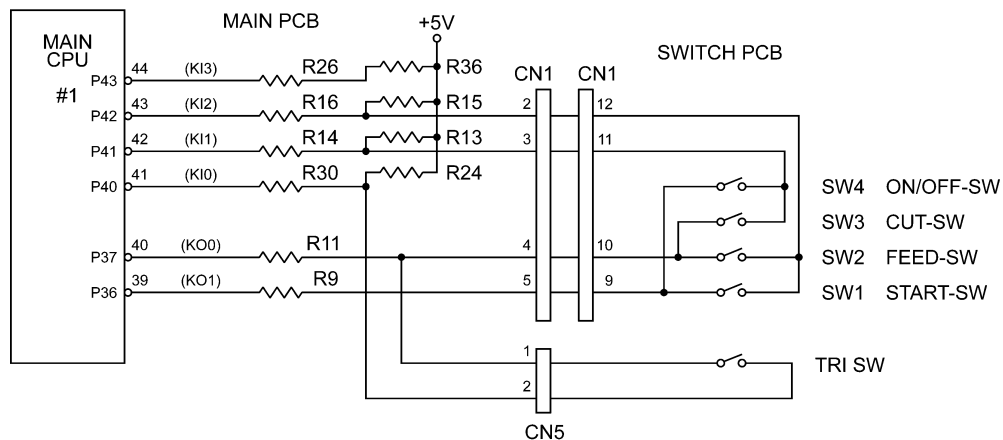

Fig. 5.4-1 Switch Scan Circuit

- Dial Switch Circuit

This circuit detects the automatic cutting mode selected on the Cutting mode selector switch.

This circuit comprises two leaf switches (ON/OFF-R, ON/OFF-L) mounted on each side of the dial switch. The signals detected by these two leaf switches are input to the Main PCB via the Switch PCB. When the dial is turned, one leaf switch turns ON and the other turns OFF.

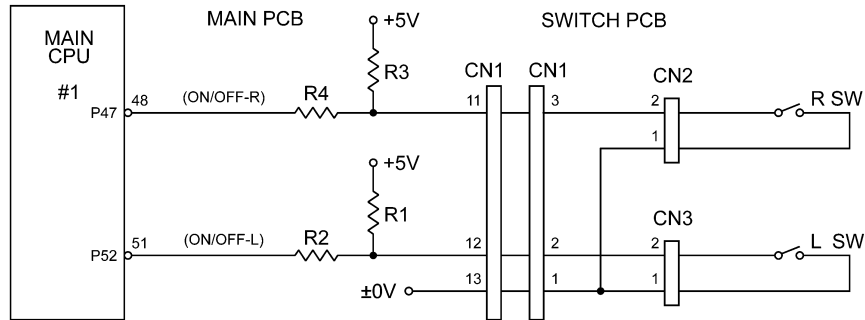

Fig. 5.4-2 Dial Switch Circuit

- Cover Switch Circuit

This circuit detects whether the cover is open or closed.

The cover switch is located in the center of the body cover. The signal detected by the cover switch (leaf switch) is input to the Main PCB via the Switch PCB. The cover switch turns OFF when the cover is open and the CPU input signal (COVER) P10 becomes High status.

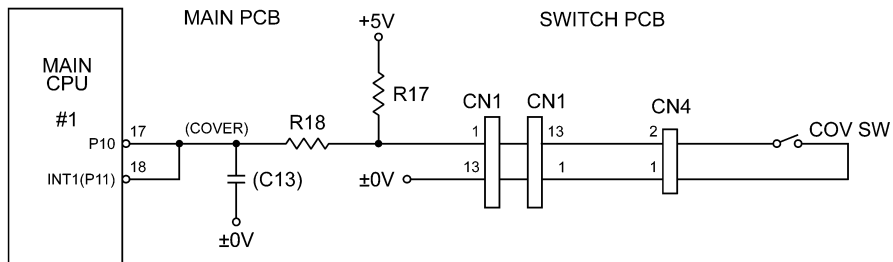

Fig. 5.4-3 Cover Switch Circuit

- Paper Width Detector Circuit

This circuit detects the width of the document and determines the Y-carriage position. It also determines the Y-carriage standby position when the power is ON or the cover is closed.

This circuit comprises the transmissive photosensor YCA-F mounted on the Paper size detector PCB that is attached to the Y-carriage. If the Y-carriage is in its standby position, the sensor lever cuts the photosensor. When the main CPU output P31 (YCA-LED) is Low, the input signal P63 (YCA-F) becomes Low.

When a document is inserted, the Y-CA motor rotates to move the Y-carriage to the edge of the document, where it moves the sensor lever cutting off the photosensor and thereby detects the edge of the document. The selected automatic cutting mode is also used to determine the Y-carriage (Y-cutter) position.

When the document edge is detected, the main CPU input signal P63 (YCA-F) becomes Low. However, as P31 is normally at High status, the photosensor does not operate and the main CPU input signal P63 (YCA-F) remains High, irrespective of the Y-carriage position.

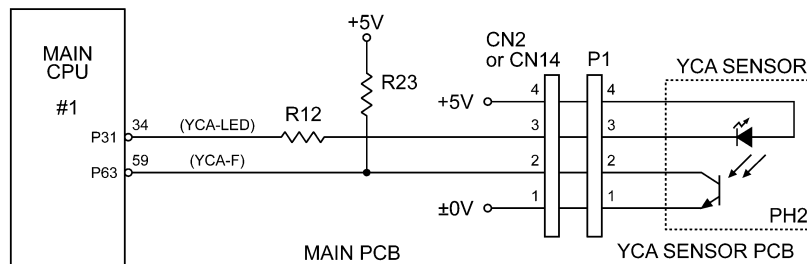

Fig. 5.4-4 Paper Width Detector Circuit

- Paper Length Detector Circuit

This circuit detects the length of the document and determines the X-cutter position.

The paper length detect switch P-END (paper sensor) is attached to the paper feed roller unit. When a document is inserted, the sensor lever turns ON the switch and the CPU input signal becomes Low status.

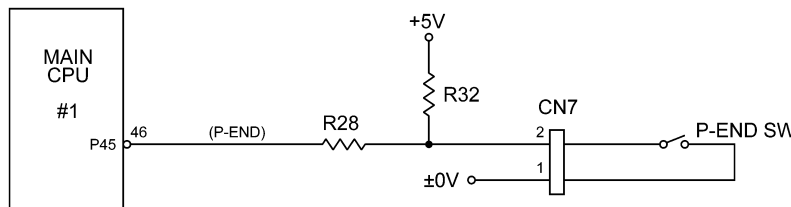

Fig. 5.4-5 Paper Length Detector Circuit

- **Film Feed Detector Circuit**

This circuit detects the film feed status to prevent jams if a problem occurs.

The film feed detector switch TPS is mounted before the paper eject roller and if there's no problem with the film during document feed or compression, the film presses against the film feed detector switch TPS and sets the ON (input Low).

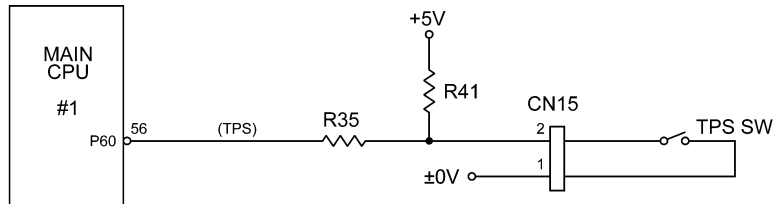

Fig. 5.4-8 Film Feed Detector Circuit

- **Input Voltage Detector Circuit**

This circuit detects the AC adaptor output voltage to prevent danger due to an AC adaptor that is faulty or incorrectly inserted.

The circuit detects high voltages using transistor Q7.

When the AC adaptor output voltage is below approximately 23 V, transistor Q7 is ON. When +24V DC is applied to R80 and R81, port P66 of the main CPU becomes approximately 4 V, and a High status is detected.

If the AC adaptor output voltage exceeds approximately 23 V, transistor Q7 turns OFF and port P66 of the main CPU detects a Low status. As the normal output voltage of the AC adaptor does not exceed approximately 23 V, port P66 of the main CPU is normally at High status.

This circuit detects low voltages using ZD1 and transistor Q6.

When the AC adaptor output voltage exceeds approximately 16 V, ZD1 is conducting and transistor Q6 is ON. Port P67 of the main CPU detects a Low status.

If the AC adaptor output voltage drops below approximately 16 V, ZD1 becomes non-conducting and transistor Q6 turns OFF. Port P67 of the main CPU detects a High status. As the normal output voltage of the AC adaptor does exceeds approximately 16 V, port P67 of the main CPU is normally at Low status.

The main CPU does not process port P67.

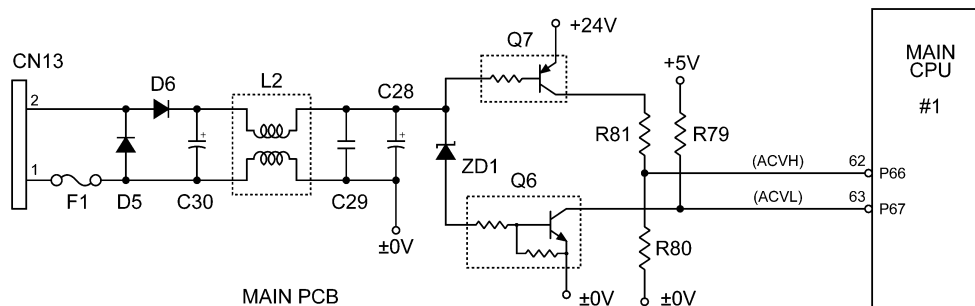

Fig. 5.4-9 Input Voltage Detector Circuit

5.5 Motor Drive Circuits

- Paper Feed Motor Drive Circuit (LF Motor)

This circuit drives the paper feed motor using 2-2 phase excitation from the +24V DC stabilized constant voltage.

The stepping motor excitation phases A, B, C, and D are controlled by main CPU ports P72, P73, P70, and P71, respectively. The four transistor arrays incorporated into QA2 drive the paper feed motor.

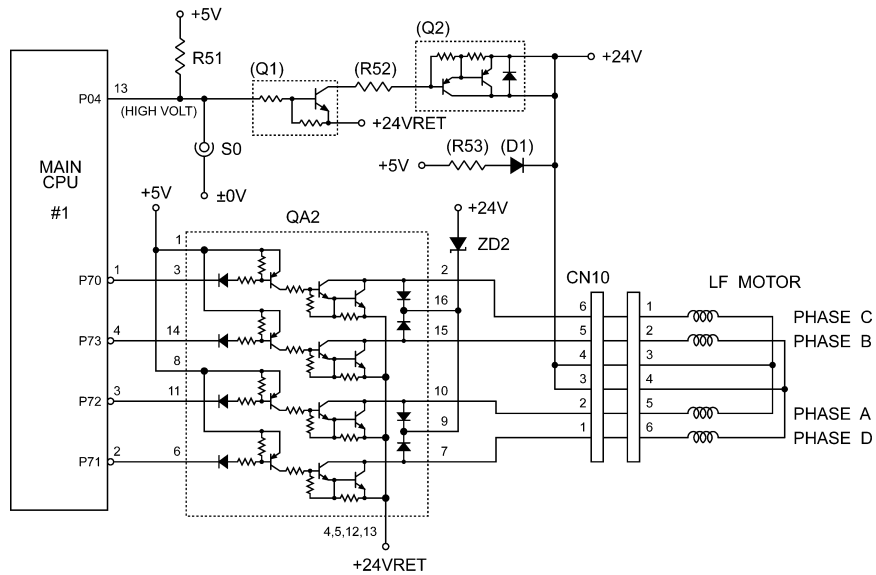

Fig. 5.5-1 Paper Feed Motor Drive Circuit

- Trimming Motor Drive Circuit

This circuit drives the trimming motor using 2-2 phase excitation from the +24V DC stabilized constant voltage.

The stepping motor excitation phases A, B, C, and D are controlled by main CPU ports P76, P77, P74, and P75, respectively. The four transistor arrays incorporated into QA1 drive the trimming motor.

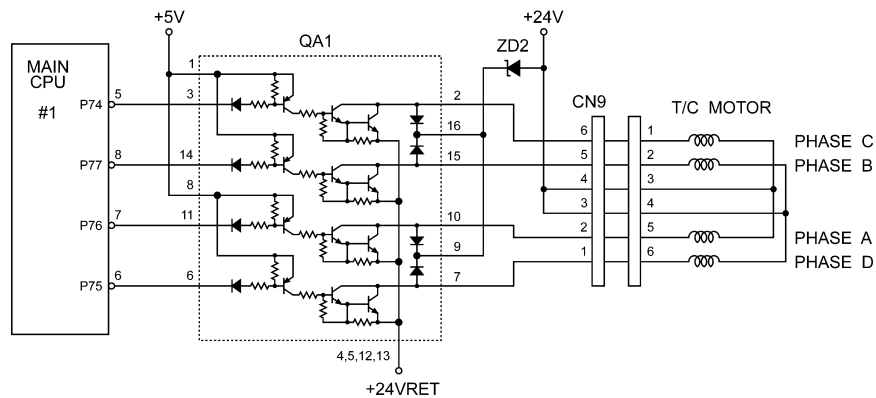

Fig. 5.5-2 Trimming Motor Drive Circuit

- Trimming Motor Start Point Detect Circuit

This circuit rotates the trimming cam and Y-cutter cam forward and backward with the trimming motor (T/C motor) to detect the position of each cam.

The trimming switch (TRG) is designed to turn OFF 150 steps before the trimming cam standby position (T-cutter top position). Consequently, TRG switch is normally ON.

The Y-cutter switch (Y-G) is designed to turn OFF at the Y-cutter top position. When the power is turned on, the circuit checks that the Y-G switch is OFF. If the switch is ON, the trimming motor reverses until the switch turns OFF. The position of the TRG switch is not checked at power ON.

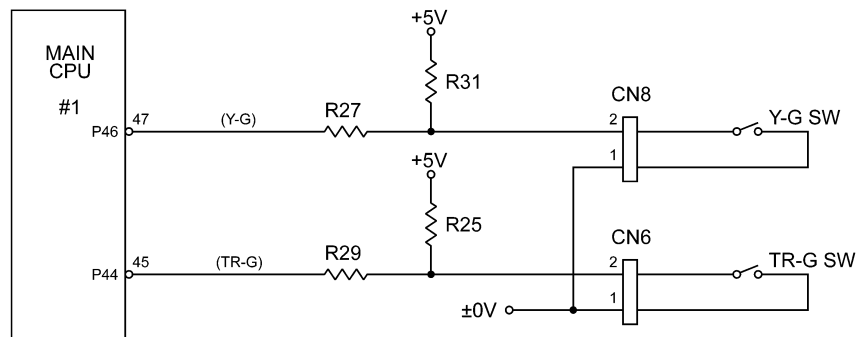

Fig. 5.5-3 Trimming Motor Start Point Detect Circuit

- Y-CA Motor Drive Circuit

This circuit drives the Y-CA motor using 2-2 phase excitation from the +24V DC stabilized constant voltage and maintains a low voltage during Y-cutter operation.

The stepping motor excitation phases A, B, C, and D are controlled by main CPU ports P03, P02, P01, and P00, respectively. The seven transistor arrays incorporated into QA3 drive the Y-CA motor.

The drive voltage is controlled by the main CPU port P65, which applies +24V DC to the Y-CA motor through transistors Q3 and Q4.

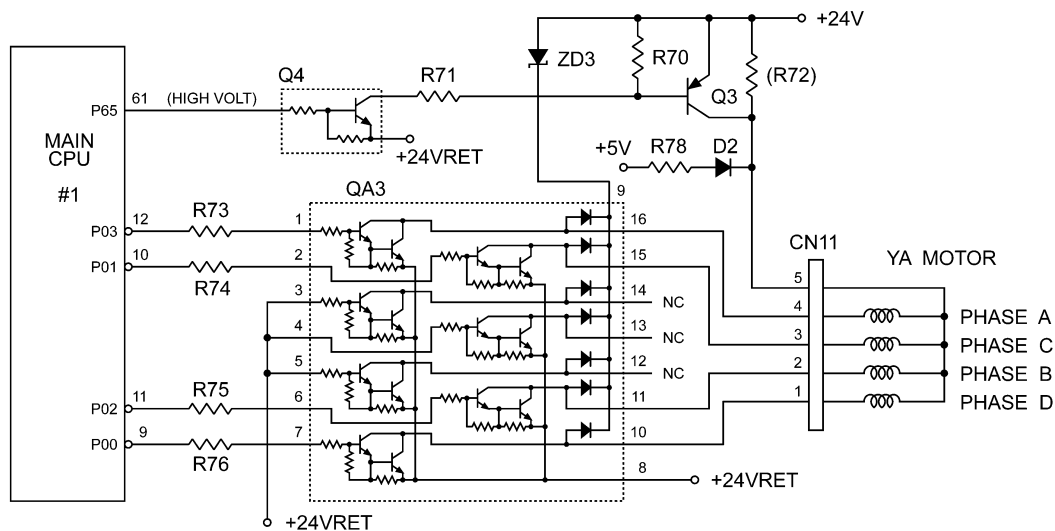

Fig. 5.5-4 Y-CA Motor Drive Circuit

5.6 Power Supply Circuits

The power supply circuits receive the unstabilized DC voltage supplied to CN1 from the AC adaptor through the Jack PCB via fuse F1 (protective circuit), diode D6, and the filter circuit.

The 2-channel switching power IC (IC#6) in the circuits converts the unstabilized DC voltage into a stabilized +5V voltage (logic power supply) and into a stabilized +24V DC voltage (drive power supply).

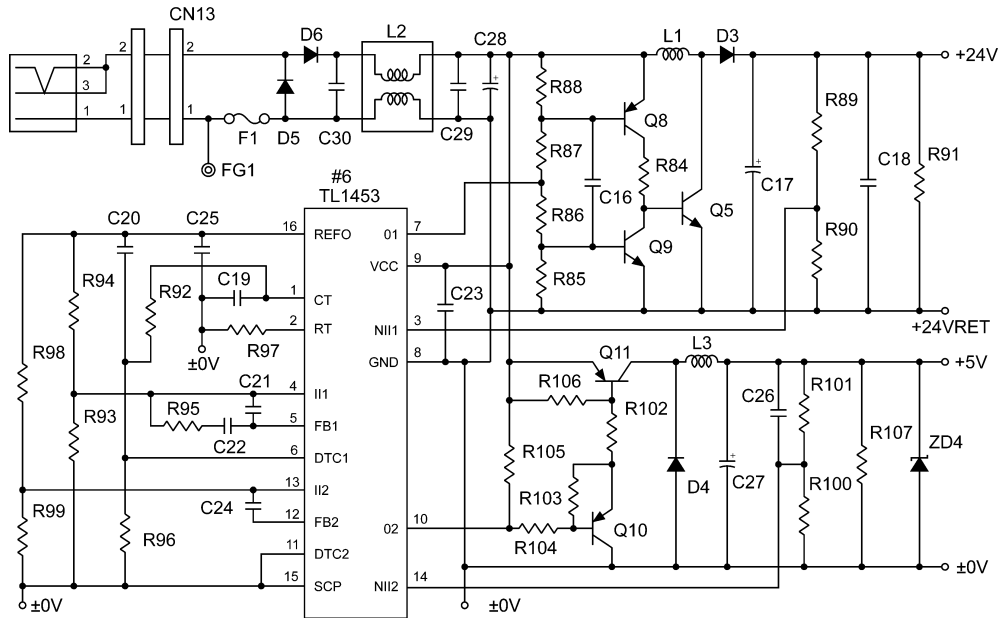

Fig. 5.6-1 Power Supply Circuits

- +5V Power Supply

Fig. 5.6-2 shows the timing chart of the power IC (IC#6) for the +5V DC power supply during idling.

In this circuit, the transistor Q11 switches at approximately 100 kHz to convert the unstabilized input voltage to a stabilized +5V supply.

When transistor Q11 is ON, energy accumulates in the coil L3 and electrolytic capacitor C27 until they are able to supply a +5V voltage. Transistor Q11 turns OFF and the energy is supplied by diode D4. The transistor Q11 switching ratio is changed by the load current to create a stable supply. This control is conducted in the power IC.

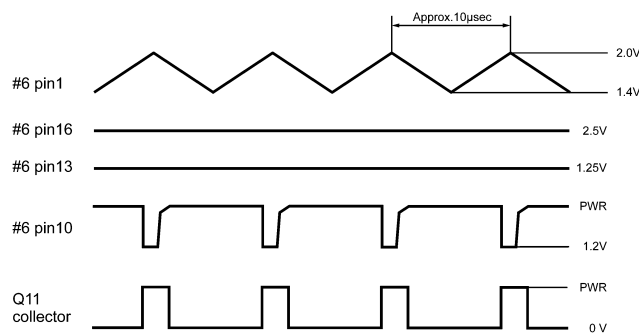

Fig. 5.6-2 +5 V Timing Chart

- +24V Power Supply

Fig. 5.6-3 shows the timing chart for the +24V DC power supply during idling.

In this circuit, the transistor Q5 switches at approximately 100 kHz to convert the unstabilized input voltage to a stabilized +24V supply.

When transistor Q5 is ON, energy accumulates in the coil L1. When transistor Q5 turns OFF, this energy is supplied through diode D3 to the electrolytic capacitor C17, where it accumulates and is output as +24V DC.

The transistor Q5 switching ratio is changed by the load current to create a stable supply. This control is conducted in the power IC.

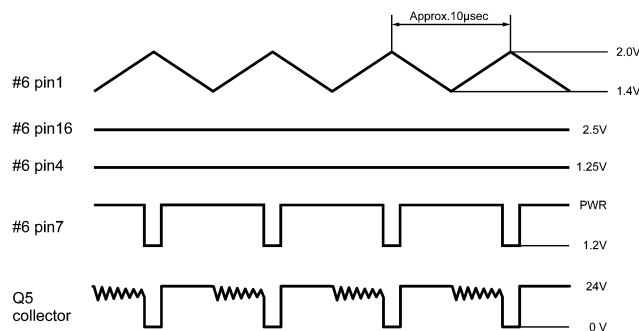

Fig. 5.6-3 +24V Timing Chart

Chapter 6.
MAINTENANCE

CONTENTS

Chapter 6. MAINTENANCE

6.1	Lubrication	6-1
6.1.1	Table of Lubricants	6-1
6.1.2	Precautions during Lubrication	6-1
6.1.3	Lubrication Positions	6-1
6.2	Replacing the Cartridge and Film	6-9
6.2.1	Replacing the Cartridge	6-9
6.2.2	Replacing the Sheet	6-12
6.3	Adjustments	6-17
6.3.1	Adjusting the Right Y-cutting Position (Border Mode)	6-17
6.3.2	Adjusting the Left Y-cutting Position	6-18
6.3.3	Adjusting Perpendicularity of Chassis and Document	6-19
6.4	Quick way to clean X-cutter	6-20

6.1 Lubrication

After the parts of 6.1.3 are replaced, apply lubricant to the positions indicated in 6.1.3 Lubrication Positions below. If only one of a pair of touching parts is replaced, lubricant remains on the other part and no further lubrication is required. If both of a pair of touching parts is replaced, lubricant must be applied to the indicated position.

6.1.1 Table of Lubricants

Use the lubricants designated below. The codes in the table below are used in the descriptions in section 6.1.3.

Code	Lubricant Name
E	Epinoc grease #1
S	Silicon grease KS64F

6.1.2 Precautions during Lubrication

- Do not apply lubricant to parts other than the specified parts. The lubricant may adversely affect plastic parts or PCBs.
- Take care not to apply too much lubricant, which can then drip onto other parts. As a guideline, apply a drop the size of a grain of rice.
- Apply lubricant to contacting areas or sliding surfaces of each part at the designated position.

6.1.3 Lubrication Positions

- ◆ Chassis
 - Chassis L Planet Gear Holder (two positions)

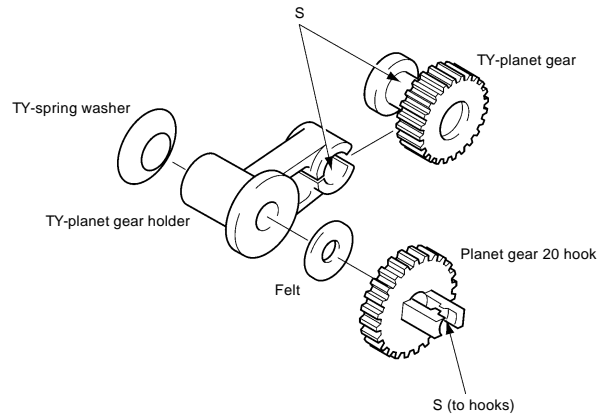

Fig. 6.1-1 Chassis L Planet Gear Holder

- Chassis L LF motor Gear

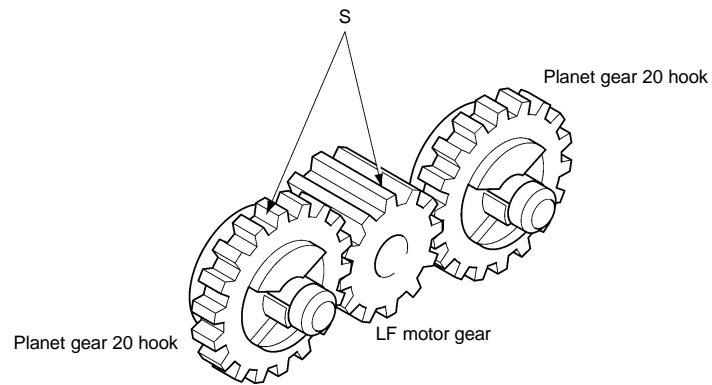

Fig. 6.1-2 Chassis L LF motor Gear

- Chassis R TC motor Gear

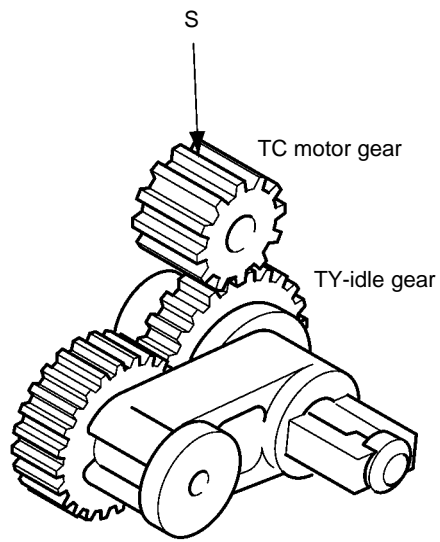

Fig. 6.1-3 Chassis R TC motor Gear

- Chassis L/R TY-planet Gear Holder

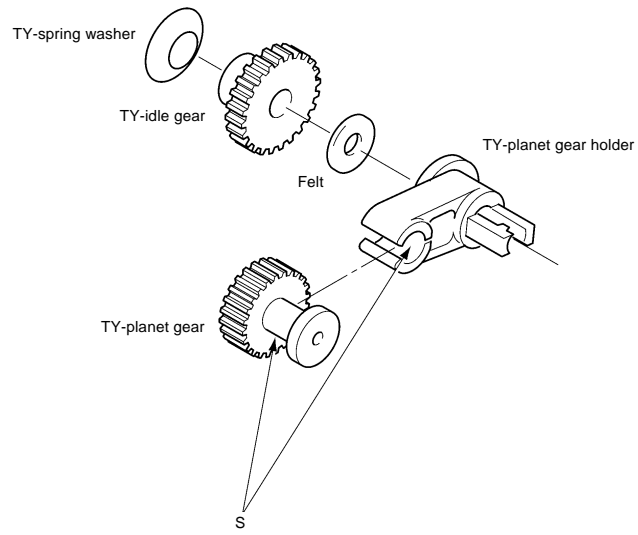

Fig. 6.1-4 Chassis L/R TY-planet Gear Holder

- Top of Chassis L/R

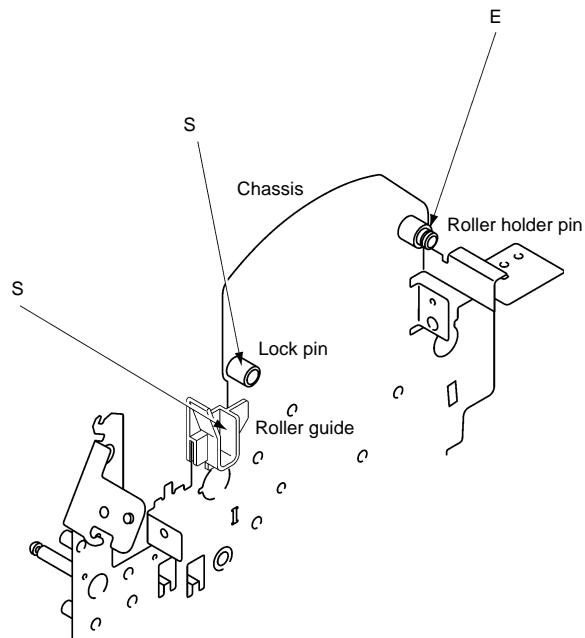

Fig. 6.1-5 Top of Chassis L/R

◆ Roller Holder (left and right)

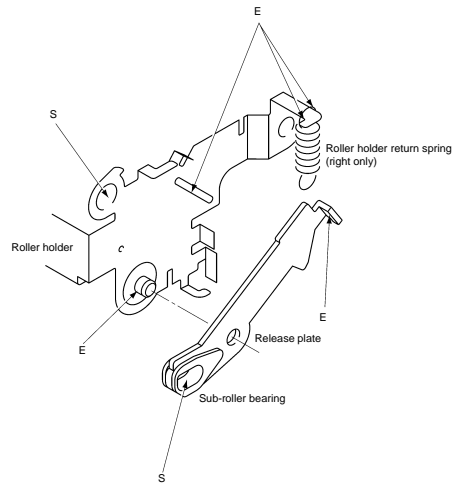

Fig. 6.1-6 Roller Holder

◆ Y-cutter Arm L

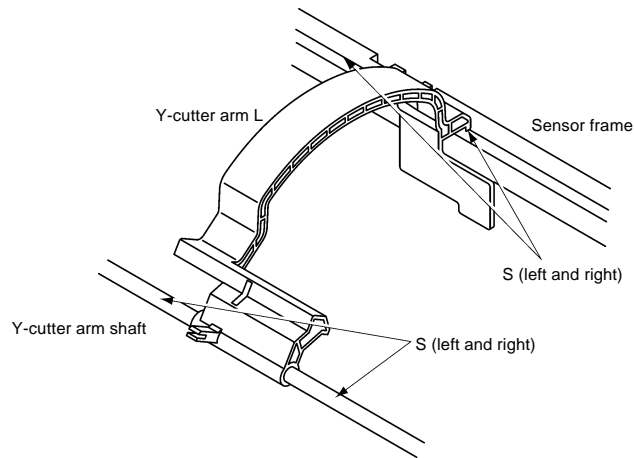

Fig. 6.1-7 Y-cutter Arm L

- ◆ Paper Eject Roller
- Paper Eject Roller

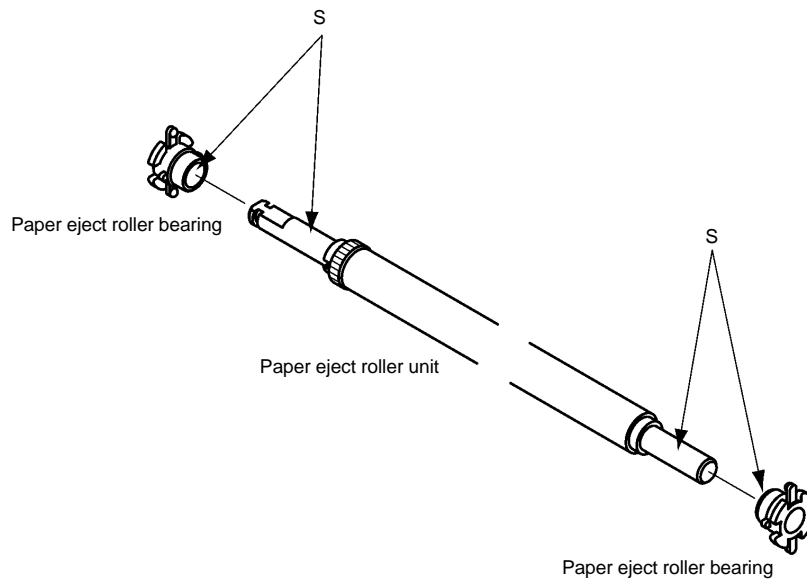

Fig. 6.1-8 Paper Eject Roller

- Paper Eject Sub-roller

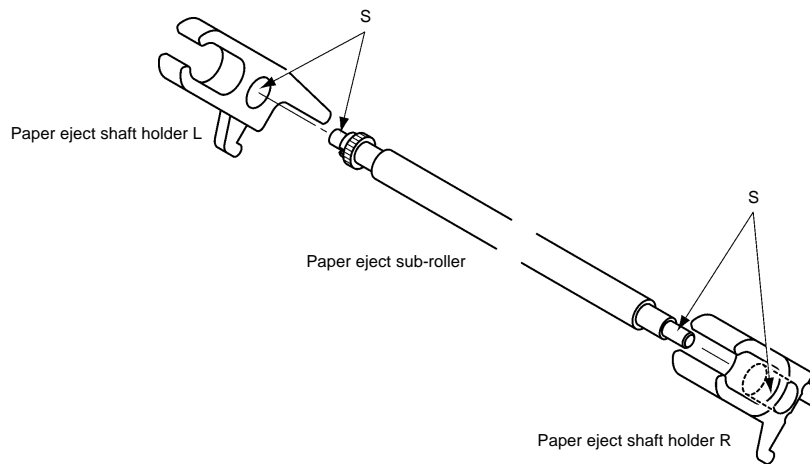

Fig. 6.1-9 Paper Eject Sub-roller

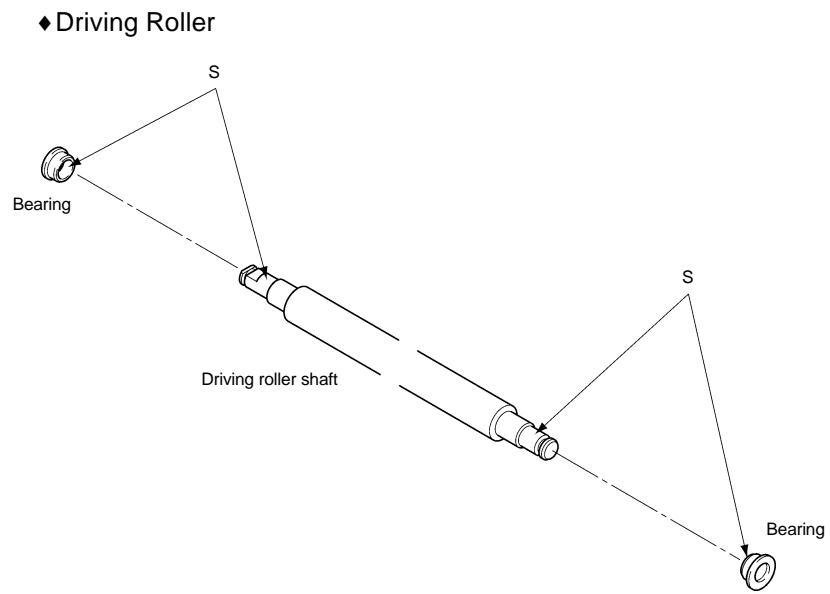

Fig. 6.1-10 Driving Roller

◆ T-Chassis Unit

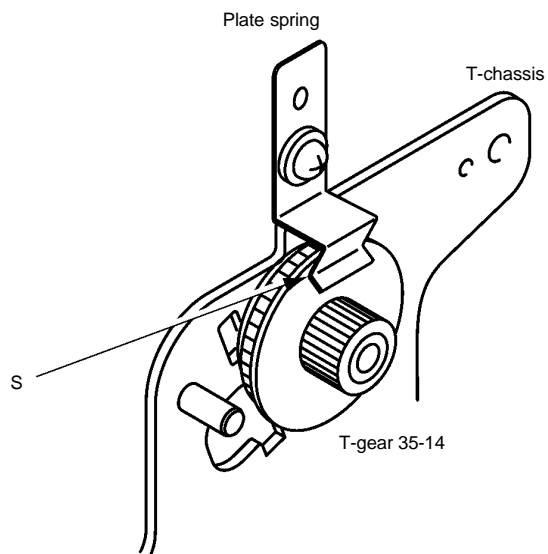

Fig. 6.1-11 T-Chassis Unit

◆ Y-CA Chassis Assy

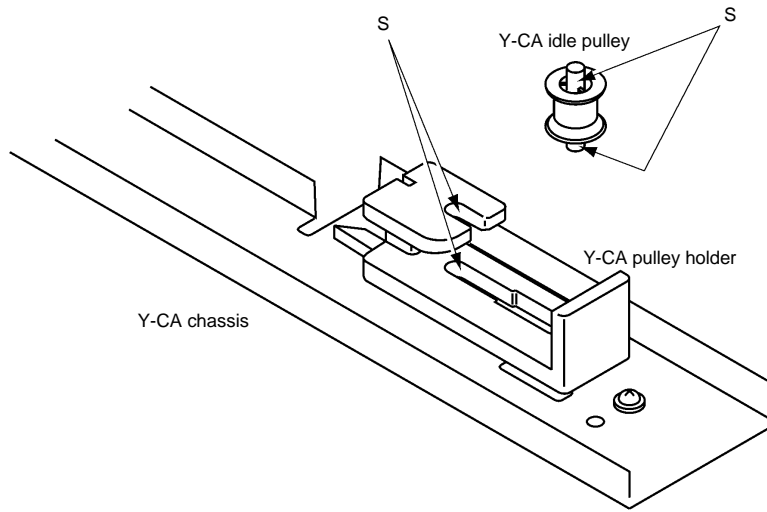

Fig. 6.1-12 Y-CA Chassis Assy

◆ Dial Switch

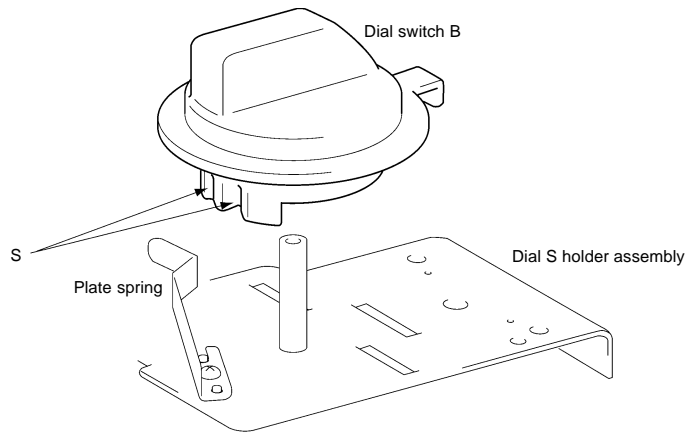

Fig. 6.1-13 Dial Switch

◆ Y-Diversion Lever

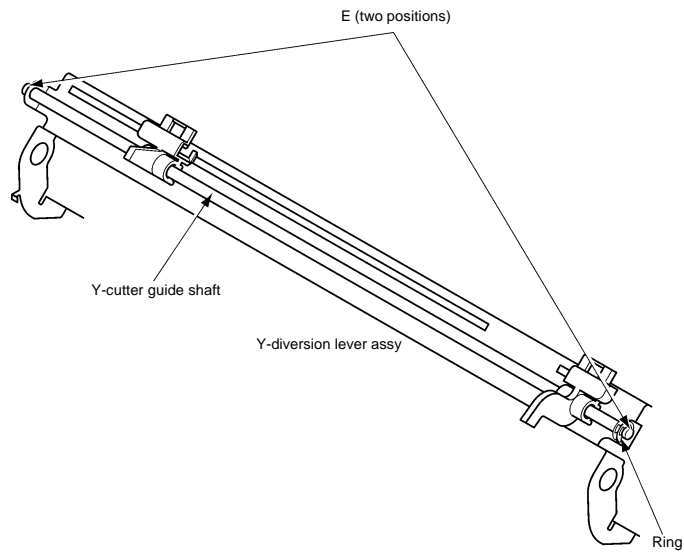

Fig. 6.1-14 Y-Diversion Lever

6.2 Replacing the Cartridge and Film

6.2.1 Replacing the Cartridge

- [1] Turn off the power switch and open the top cover.

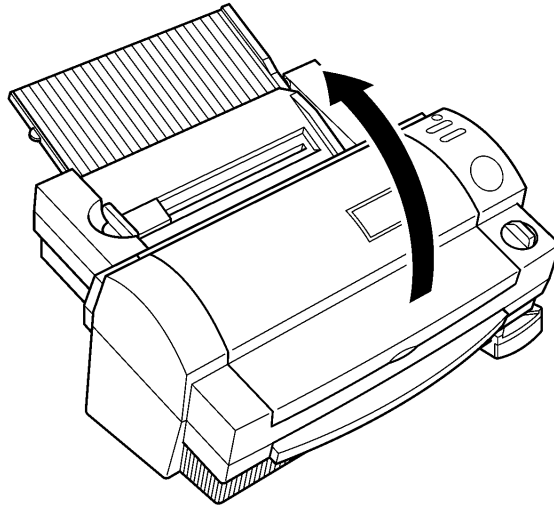

Fig. 6.2-1 Replacing the Cartridge (1/6)

- [2] Push the lock lever R in the direction of the arrow to unlock the roller holder assembly. Hold the set buttons and lift out the roller holder assembly.

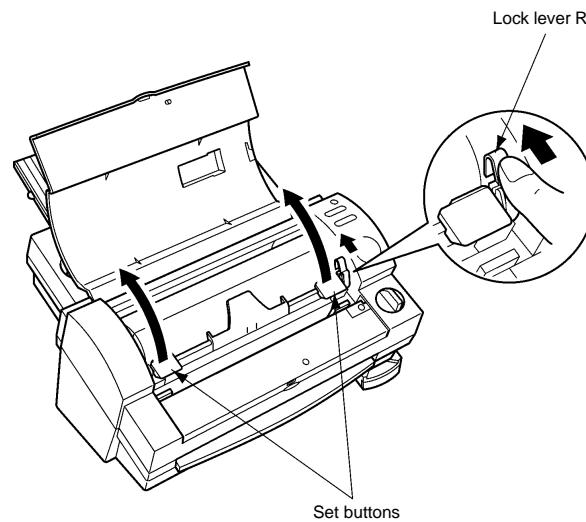

Fig. 6.2-2 Replacing the Cartridge (2/6)

[3] Carefully remove the cartridge.

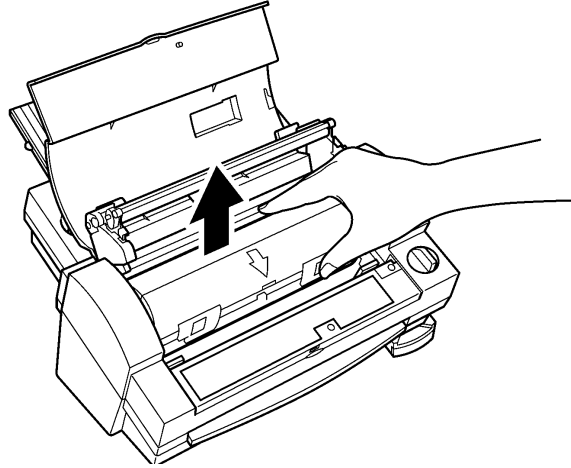

Fig. 6.2-3 Replacing the Cartridge (3/6)

[4] Orient the new cartridge with the arrow mark facing forward and carefully insert it. Check the following items before inserting the cartridge.

- Cartridge shutter is fully closed.
- The edge of the sheet is parallel with the cartridge film outlet. If the edge is not parallel, cut it parallel with scissors.
- The edge of the sheet is below the Y-cutter unit.

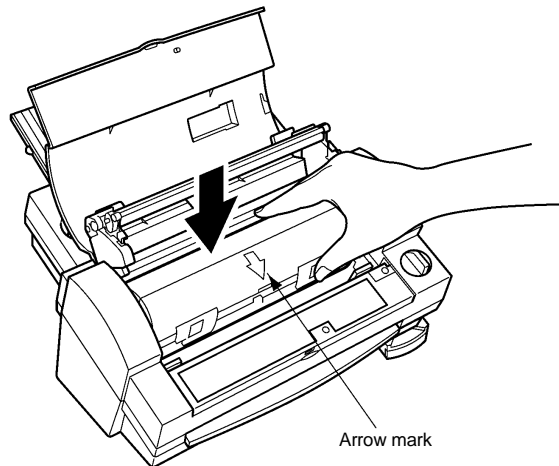

Fig. 6.2-4 Replacing the Cartridge (4/6)

- [5] Lower the roller holder assy and push the set buttons in the direction of the arrows to lock the roller holder assy in position.

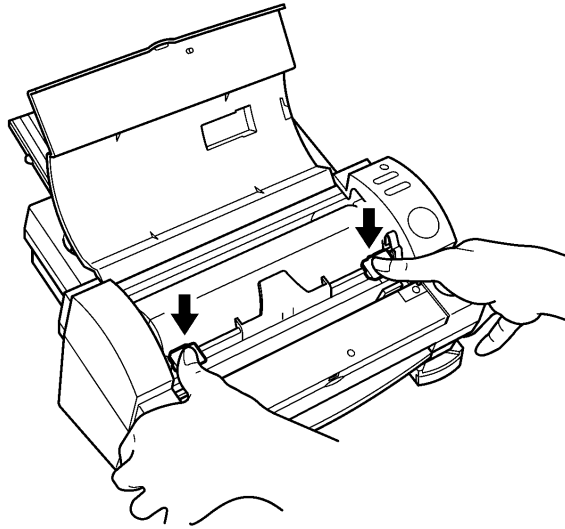

Fig. 6.2-5 Replacing the Cartridge (5/6)

- [6] Close the top cover.

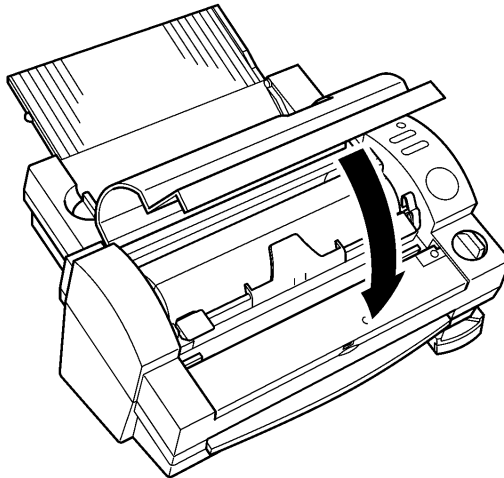

Fig. 6.2-6 Replacing the Cartridge (6/6)

- [7] Turn on the power switch and press the Feed button to feed out some sheet and remove the slackness in the sheet. Hold down the Feed button until the edge of the sheet reaches the eject gate.
- [8] Press the Cut button to cut off the end of the sheet fed out to remove the slackness.

6.2.2 Replacing the Sheet

[1] Carefully remove the cartridge.

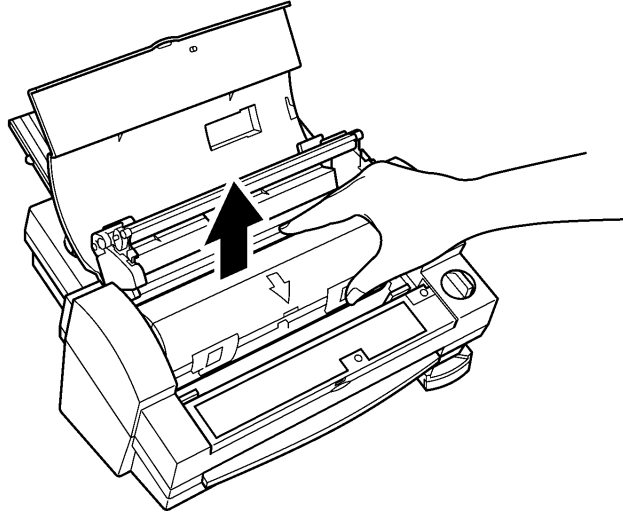

Fig. 6.2-7 Replacing the Sheet (1/9)

[2] Open the cartridge shutter, then open the cartridge cover.

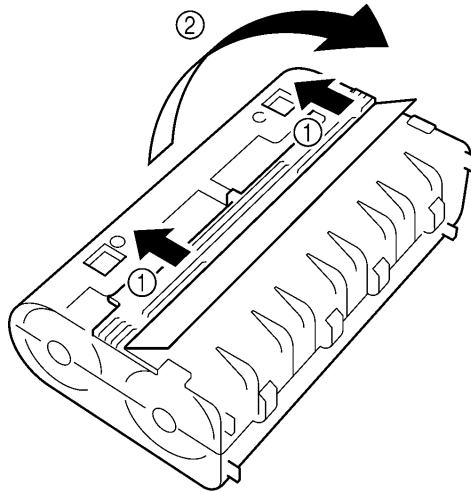

Fig. 6.2-8 Replacing the Sheet (2/9)

[3] Remove the old sheet.

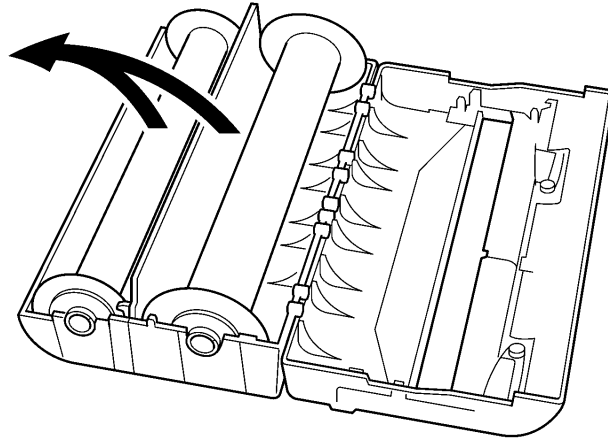

Fig. 6.2-9 Replacing the Sheet (3/9)

[4] Hold the yellow plastic holders of the new sheet and insert the sheet in the cartridge as shown in the diagram. It is not possible to insert the sheet in the wrong direction.

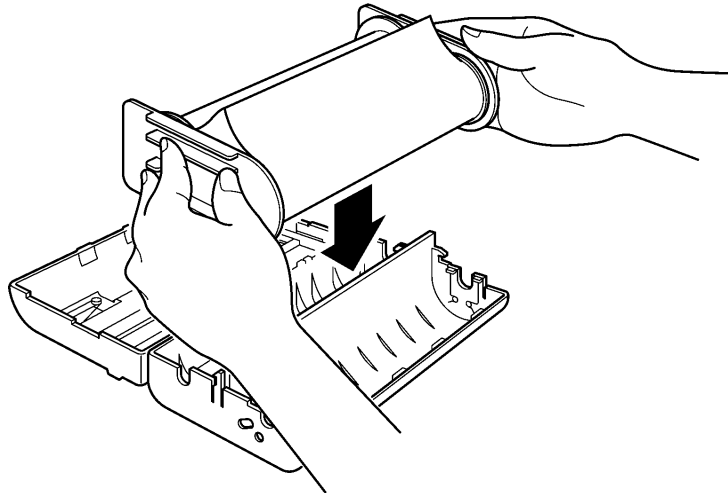

Fig. 6.2-10 Replacing the Sheet (4/9)

- [5] Close the cartridge cover, ensuring that the edge of the sheet protrudes from the cartridge film outlet.

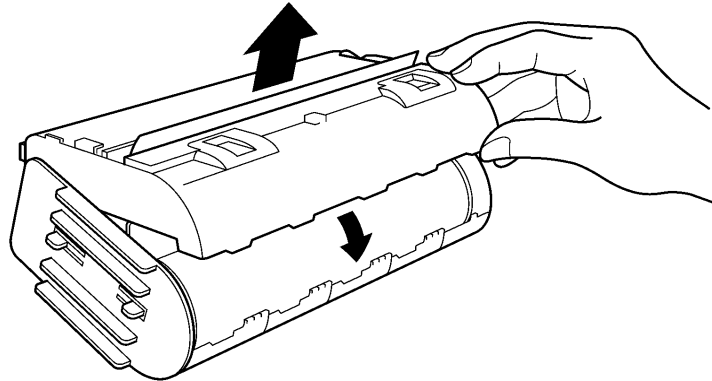

Fig. 6.2-11 Replacing the Sheet (5/9)

- [6] Press the shutter buttons and close the shutter.

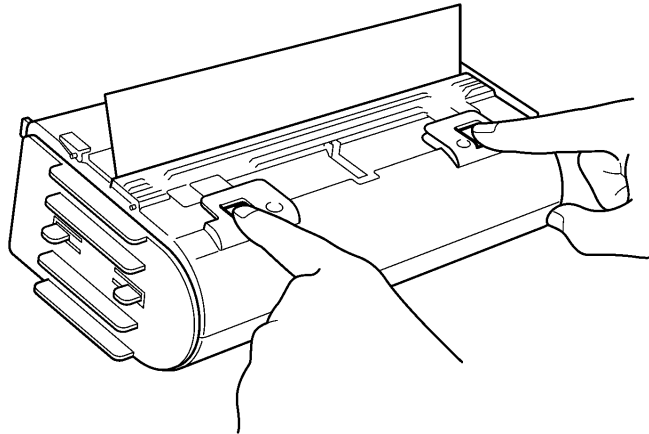

Fig. 6.2-12 Replacing the Sheet (6/9)

- [7] Press the catches on the yellow plastic holders and remove them in the sequence shown.

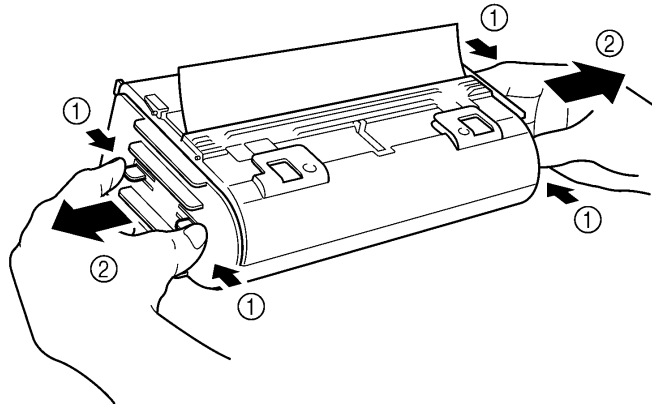

Fig. 6.2-13 Replacing the Sheet (7/9)

- [8] Check that the edge of the sheet is parallel with the cartridge film outlet. If the edge is not parallel, cut it parallel with scissors.

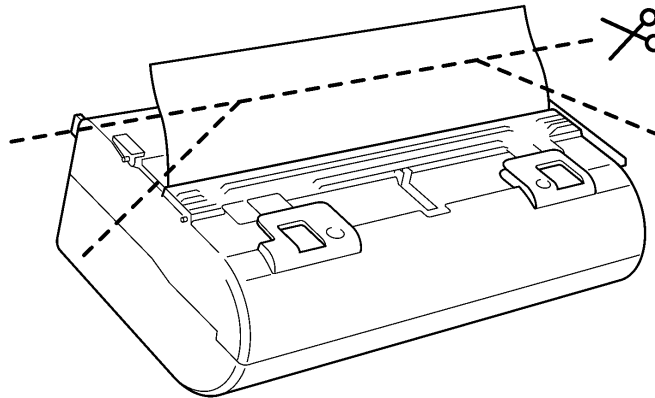

Fig. 6.2-14 Replacing the Sheet (8/9)

[9] Orient the cartridge with the arrow mark facing forward and carefully insert it.

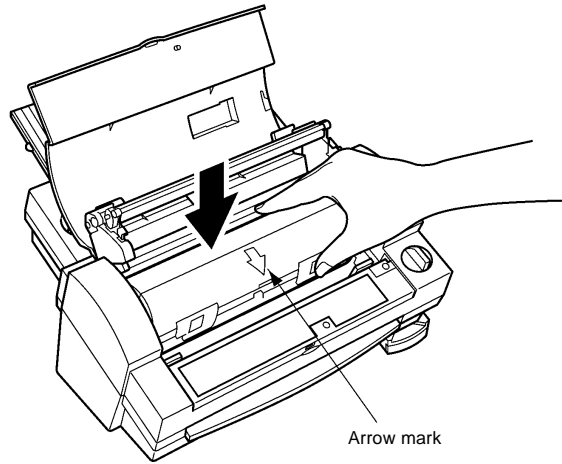

Fig. 6.2-15 Replacing the Sheet (9/9)

Note: After removing sheet from its sealed pack, it will dry up if not inserted into the cartridge.

6.3 Adjustments

6.3.1 Adjusting the Right Y-cutting Position (Border Mode)

Loosen the screw and move slide plate 2 in the direction of the arrow indicated in the diagram below. This moves the Y-cutter attached to the Y-cutter guide and adjusts the cutting position for the right edge of the sheet.

In the diagram below, move slide plate 2 in the direction of the arrow to increase the border of the laminated document.

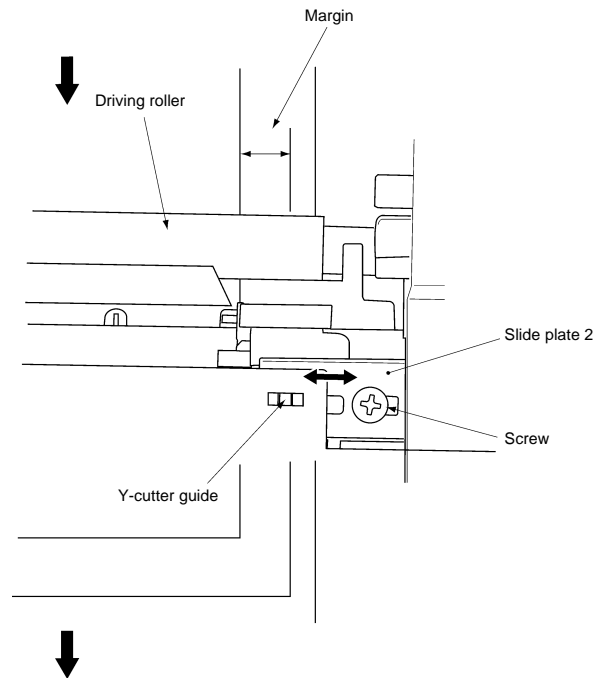

Fig. 6.3-1 Adjusting the Right Y-cutting Position

6.3.2 Adjusting the Left Y-cutting Position

Loosen the screw and move the photosensor (PS) PCB holder left or right. This moves the detection position of the sensor attached to the photosensor (PS) PCB holder and adjusts the cutting position for the left edge of the sheet.

In the diagram below, move the photosensor (PS) PCB holder to the right to increase the border of the laminated document.

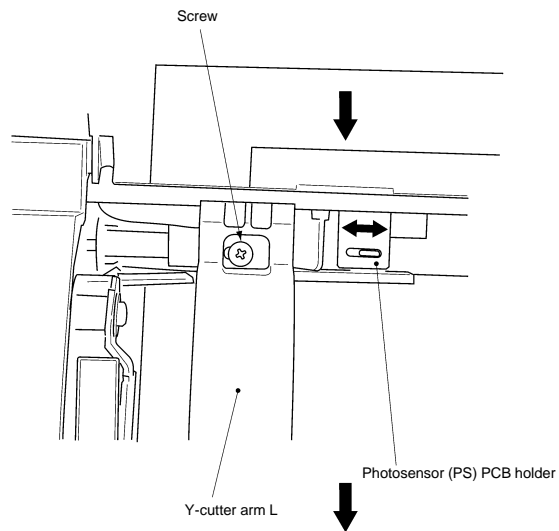

Fig. 6.3-2 Adjusting the Left Y-cutting Position

6.3.3 Adjusting Perpendicularity of Chassis and Document

1. Loosen the four screws under the bottom cover, as shown in the diagram.
2. Insert the Slant adjust plate between the paper feed roller and paper feed sub-roller until the edge of the gauge is near the fixed cutter.
3. Check that the side of the gauge lies against the sub-tray rib. Turn the chassis about the pivot until the fixed cutter mounted on the chassis is parallel with the edge of the gauge.
4. After adjusting the fixed cutter parallel with the edge of the gauge, tighten the screws A and A', taking care not to change the chassis alignment. Remove the gauge and tighten the remaining two screws.

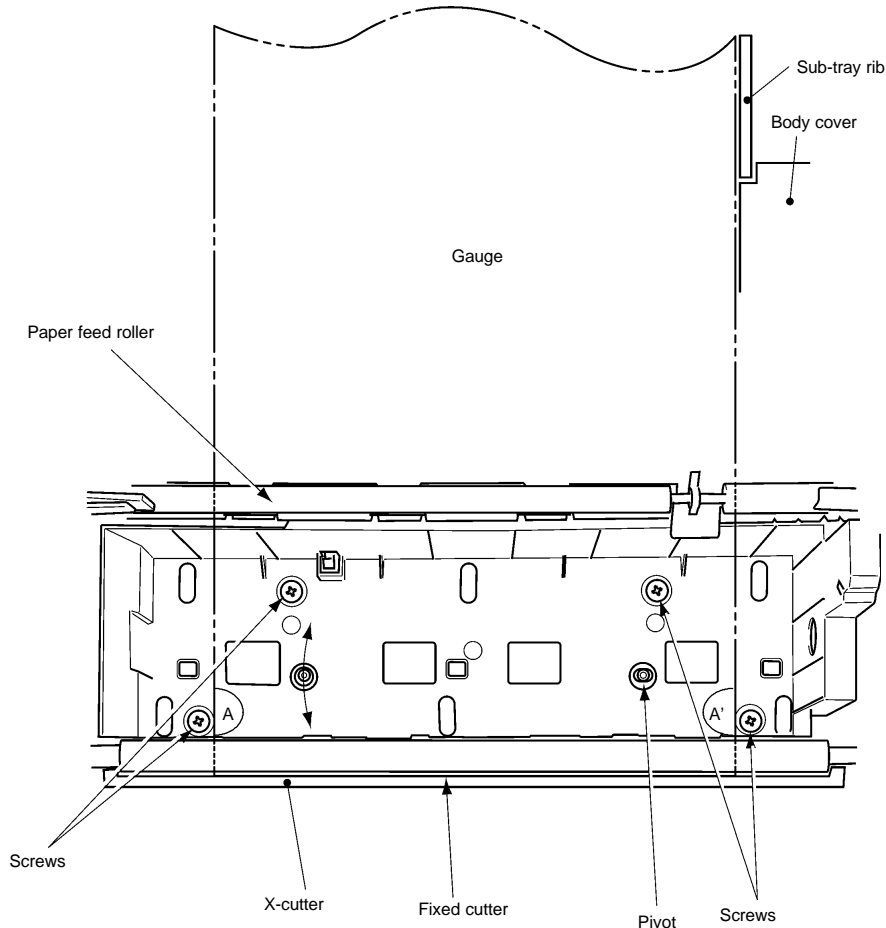

Fig. 6.3-3 Adjusting Perpendicularity of Chassis and Document

6.4 Quick way to clean X-cutter

Here's procedure for quick way to clean X-cutter.

Note that this indicates only the way of cleaning, and If mal-cutting still persists after cleaning according the way below, then replacement of X-cutter unit according disassembly procedure of Chapter 3 is necessary.

1. Disassemble machine to the extent of Fig.3.3-11 (Like Fig. 6.4-1 below)

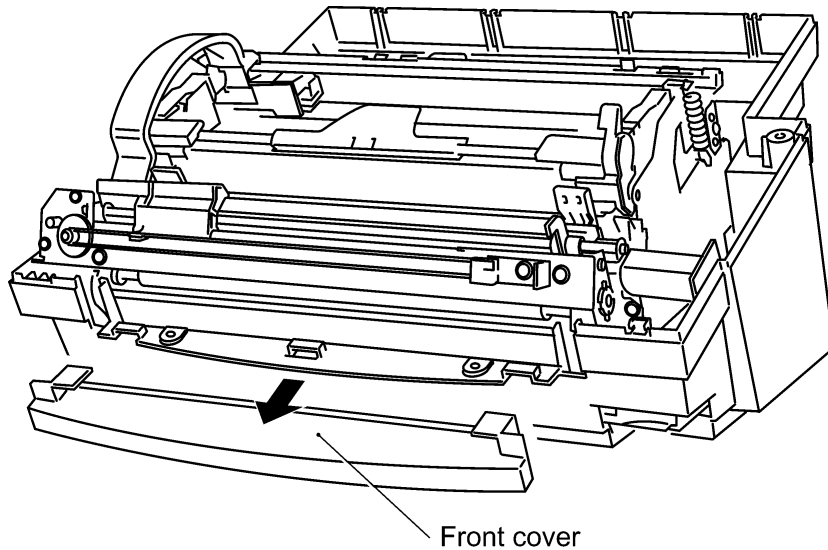

Fig. 6.4-1 Disassemble machine

2. Remove Y-CA chassis screws and Y-extension spring L to remove Y-CA chassis Assy, with chassis still assembled with bottom cover.

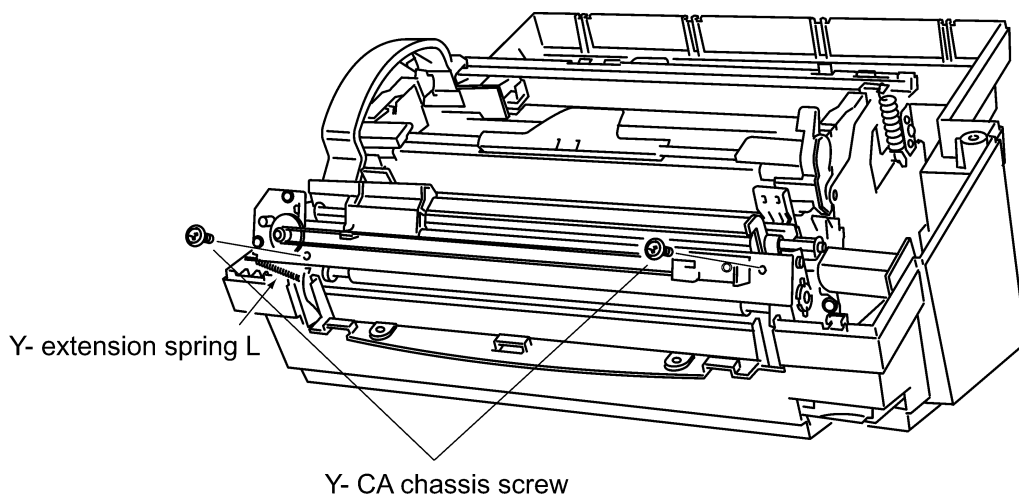

Fig. 6.4-2 Removing Y-CA chassis Assy

3. Remove Paper eject sub-roller springs.

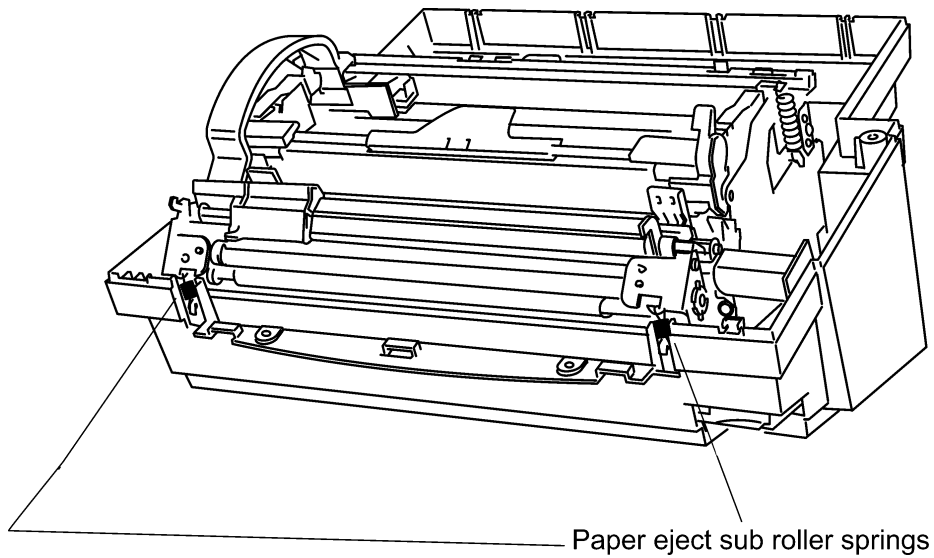

Fig. 6.4-3 Removing Paper eject sub roller springs

4. Clean fixed blade of X-cutter by inserting alcohol-soaked cotton bar into clearance between Paper eject roller and Paper eject sub-roller and sliding it horizontally, along cleaning range indicated in the Fig. below. After cleaning X-cutter, reassemble machine in the reverse order of disassembly, and start machine to check quality of X-cutting .

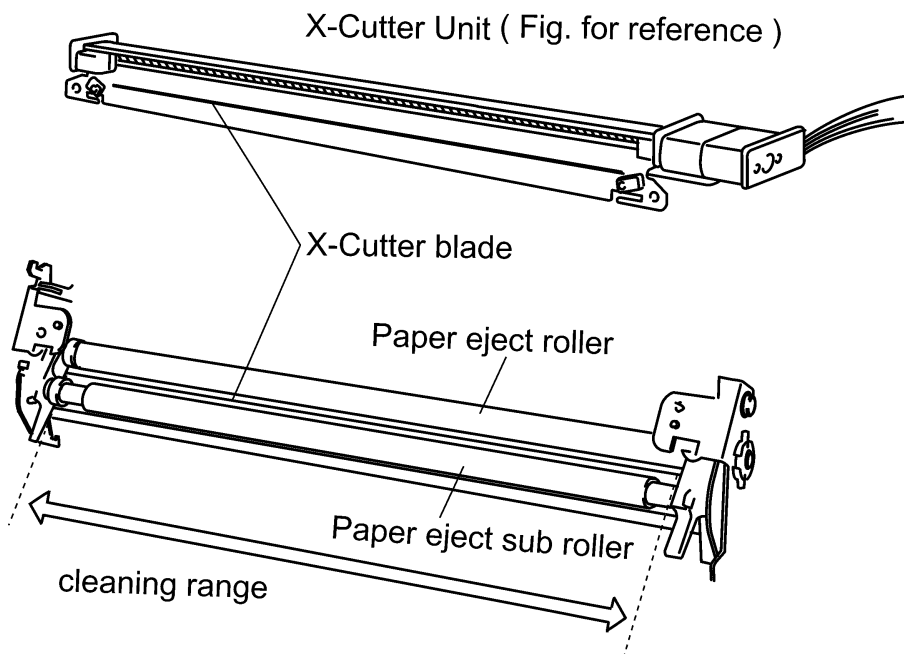

Fig. 6.4-4 Cleaning X-cutter blade

Chapter 7.

TROUBLESHOOTING

CONTENTS

Chapter 7. TROUBLESHOOTING

7.1	Outline	7-1
7.2	Precautions during Repair.....	7-1
7.3	After Making a Repair	7-1
7.4	Basic Checks.....	7-1
7.5	Troubleshooting Flowcharts.....	7-2
7.6	Troubleshooting Tables.....	7-5

7.1 Outline

It is extremely difficult to determine when and where a problem may arise and to determine the cause of a problem that did arise. It is even more difficult to formulate remedies for theoretical problems which may or may not occur. This chapter gives examples of actual problems that have occurred, together with suggested remedies. While this chapter may not allow all faults to be remedied, use it as one means of rectifying problems.

7.2 Precautions during Repair

Always follow the precautions below when repairing the unit.

1. Always unplug the AC adaptor from the main power socket before removing a cover, adjusting mechanical parts, or removing a PCB.
2. Always unplug the AC adaptor from the main power socket measuring conductivity with a circuit tester.
3. When removing a connector, pull on the body of the connector, not on the lead attached to it.

7.3 After Making a Repair

Always test the unit after diagnosing and repairing a problem to ensure that the problem is completely remedied.

When the cause of a problem is identified, make a note of it in the troubleshooting procedures for future reference.

7.4 Basic Checks

Check the following items whenever a problem occurs.

- Check the power supply voltage.
Make sure that the AC input voltage, the AC adaptor output voltage, and the DC supply voltage for each part are at the prescribed value.
- Check the connectors
Ensure that no connector is loose or disconnected.
- Check the fuses
Check if the fuse F1 or thermal fuse in the AC adaptor has blown.

7.5 Troubleshooting Flowcharts

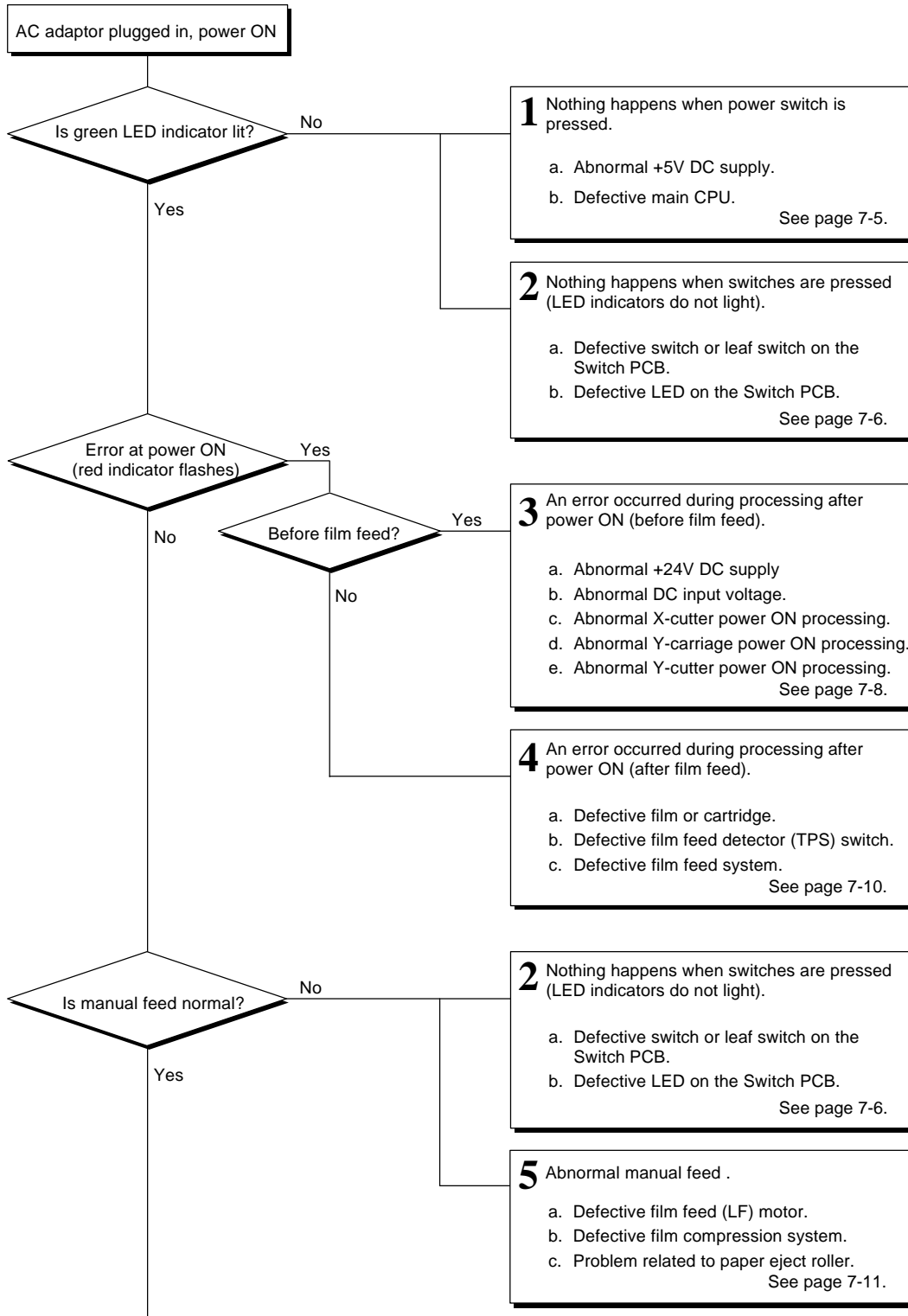

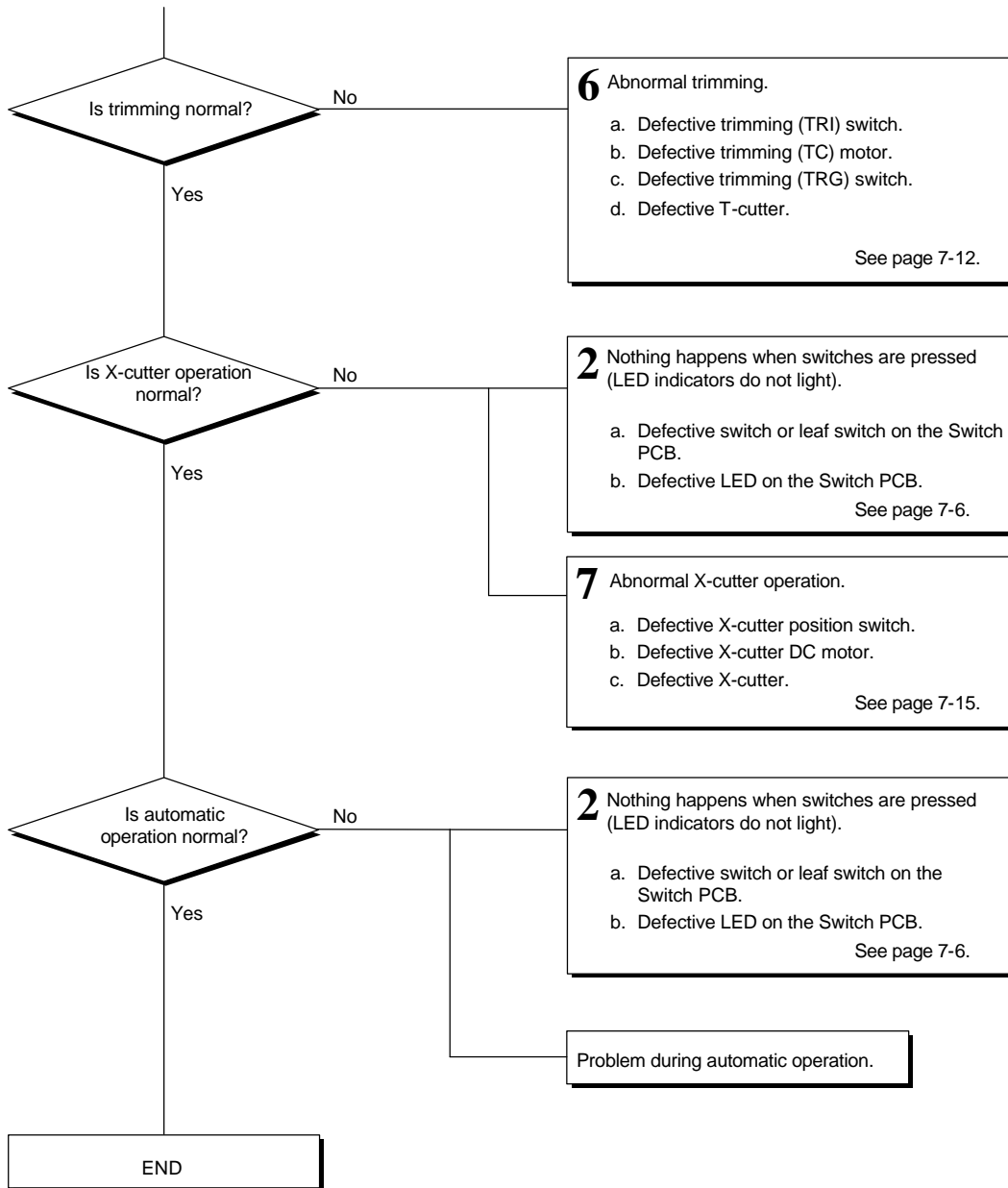

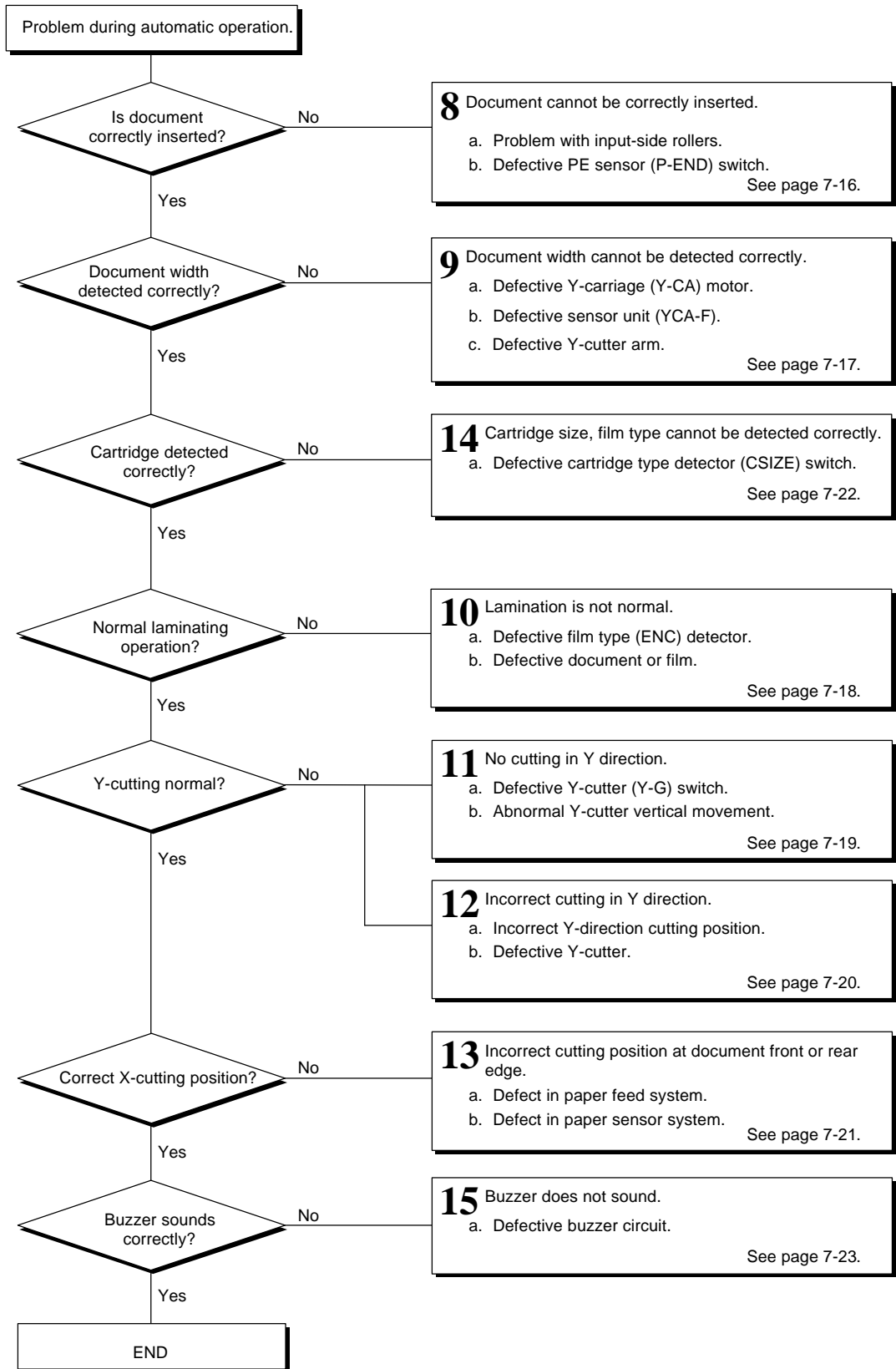

7.6 Troubleshooting Tables

1 Nothing happens when power switch is pressed. (LED indicator does not light.)

- a. Abnormal input voltage.
- b. Abnormal +5V DC supply.
- c. Defective main CPU.

Problem	Check Item	Cause	Remedy	Repair	See Section
a. Abnormal input voltage	Are AC adaptor, Jack PCB, power harness correctly connected?	Defective harness connection.	Connect harness		3.3.3 3.3.4
	Is fuse F1 on Main PCB blown?	Blown fuse.	Replace fuse.		3.3.5 3.5.1
	Is AC adaptor output voltage normal (about 21V DC at rated input)?	Defective AC adaptor.	Replace AC adaptor.		—
	Is AC adaptor voltage applied to connector CN13 on Main PCB?	Defective Jack PCB.	Replace Jack PCB.		3.3.1 4.3.2 3.3.3 3.3.4 3.3.5 3.5.2
		Defective power harness.	Replace power harness.		3.3.1 3.3.2 3.3.3 3.3.4 3.3.5 3.4.1
b. Abnormal +5V DC supply	Is power supply IC#6 pin 10 output Low or switching?	Defective power supply IC#6.	Replace Main PCB assy.	Replace IC#6.	3.3.3 3.3.4 3.3.5 3.5.1
	When power supply IC#6 pin 10 output is Low, is transistor Q10 ON?	Defective transistor Q10.	Replace Main PCB assy.	Replace Q10.	
	When transistor Q10 is ON, is transistor Q11 ON?	Defective transistor Q11.	Replace Main PCB assy.	Replace Q11.	
		Zener diode ZD4 is shorted.	Replace Main PCB assy.	Replace ZD4. Replace Q11.	
c. Defective main CPU	Is Reset (Pin 29) of the main CPU #1 High?	Defective reset IC#2.	Replace Main PCB assy.	Replace IC#2.	
	Is oscillator waveform output from XIN (Pin 30) and XOUT (Pin 31) of the main CPU?	Defective oscillator XT1.	Replace Main PCB assy.	Replace XT1.	
		Defective main CPU#1.	Replace Main PCB assy.	Replace CPU#1.	

2 Nothing happens when switches are pressed.

a. Defective switch or leaf switch on the Switch PCB.

b. Defective LED on the Switch PCB.

Problem	Check Item	Cause	Remedy	Repair	See Section
a. Defective switch or leaf switch on the Switch PCB	Is Switch PCB correctly mounted?	Defective Switch PCB mounting.	Correctly mount Switch PCB.		3.3.3 3.3.4 3.3.5 3.3.7 3.3.8 3.3.9
	Is switch harness assy correctly connected?	Defective connection of switch harness assy.	Correctly connect switch harness assy.		
	Is the red lead connector connected to CN2 on the Switch PCB?	Leaf switch assy not connected.	Correctly connect the leaf switch assy.		
	Is the white lead connector connected to CN3 on the Switch PCB?	Leaf switch assy not connected.	Correctly connect the leaf switch assy.		
	Is the yellow lead connector connected to CN4 on the Switch PCB?	Leaf switch assy not connected.	Correctly connect the leaf switch assy.		
	When switch SW1 to SW4 is pressed on the Switch PCB, does the switch become conducting?	Continuity problem in switch SW1 to SW4.	Replace the Switch PCB.	Replace switch SW1 to SW4.	
	When the cover R/cover L leaf switch is shorted, does the connector on the leaf switch assy become conducting?	Defective leaf switch assy.	Replace cover switch assy. Replace leaf switch R assy. Replace leaf switch L assy.		
	When switch SW1 to SW4 is pressed on the Switch PCB or the leaf switch assy is shorted, can the conductivity be checked at CN1 on the main CPU?	Defective switch harness assy.	Replace switch harness assy.		
	If conductivity can be checked at CN1 on the main CPU when switch SW1 to SW4 is pressed or the leaf switch assy is shorted, can the conductivity be checked at the main CPU ports?	Continuity problem in Main PCB.	Replace Main PCB assy.		
Defective series resistor on main CPU.		Replace Main PCB assy.	Replace series resistor.		
Defective main CPU#1.		Replace Main PCB assy.	Replace CPU#1.		

Problem	Check Item	Cause	Remedy	Repair	See Section
b. Defective LED on the Switch PCB	Low output from the main CPU ports P32 to P35 (Pin 35 to Pin 38) that drive indicators LED1 to LED4?	Defective main CPU#1.	Replace Main PCB assy.	Replace CPU#1.	3.3.3 3.3.4 3.3.5 3.5.1
	Does LED1 to LED4 light when Pin 6 to Pin 9 on Main PCB connector CN1 is Low?	Defective switch harness assy.	Replace switch harness assy.		3.3.3 3.3.4 3.3.5
		Defective LED1 to LED4.	Replace the Switch PCB.	Replace indicator LED1 to LED4.	3.3.3 3.3.4 3.3.5 3.3.7 3.3.8 3.3.9

3 An error occurred during processing after power ON (before film feed).

- a. Abnormal +24V DC supply
- b. Abnormal DC input voltage.
- c. Abnormal X-cutter power ON processing.
- d. Abnormal Y-carriage power ON processing.
- e. Abnormal Y-cutter power ON processing.

Problem	Check Item	Cause	Remedy	Repair	See Section
a. Abnormal +24V DC supply	Is +24V DC voltage at $\pm 0V$?	Coil L1 discharged.	Replace Main PCB Assy.	Replace L1.	3.3.3 3.3.4
		Continuity problem with diode D2.	Replace Main PCB Assy.	Replace D2.	3.3.5 3.5.1
	Does +24V DC voltage exceed 24 V, at the same level as the AC adaptor output voltage (at rated AC input)?	Defective AC adaptor.	Replace AC adaptor.		---
	Is power supply IC#6 pin 7 switching?	Defective power supply IC#6.	Replace Main PCB Assy.	Replace IC#6.	3.3.3 3.3.4 3.3.5 3.5.1
	Is transistor Q8 collector voltage switching between 0 V and input voltage?	Defective transistor Q8.	Replace Main PCB Assy.	Replace Q8.	
		Defective transistor Q9.	Replace Main PCB Assy.	Replace Q9.	
	Is transistor Q5 collector voltage switching between +24 V and 0 V?	Defective transistor Q5.	Replace Main PCB Assy.	Replace Q5.	
b. Abnormal DC input voltage	Is input voltage from AC adaptor between 16 V and 23 V (at rated input)?	Defective AC adaptor.	Replace AC adaptor.		---
	If AC adaptor input voltage is equal or below 23 V, is main CPU port P66 (Pin 62) at High level?	Defective transistor Q7.	Replace Main PCB Assy.	Replace Q7.	3.3.3 3.3.4 3.3.5 3.5.1
	If AC adaptor input voltage is equal or above 16 V, is main CPU port P67 (Pin 63) at Low level?	Defective transistor Q6.	Replace Main PCB Assy.	Replace Q6.	
		Defective Zener diode ZD1.	Replace Main PCB Assy.	Replace ZD1.	
c. Abnormal X-cutter power ON processing	X-cutter does not move at all?	Foreign matter stuck in cutter.	Clean out foreign matter.		---
		Defective X-cutter.	Replace the X-cutter unit.		3.3.1 3.3.3 3.3.4 3.3.5 3.4 3.6.1 3.7.1 3.8.1 3.8.2 3.10 3.11.1 3.12.1
	Error occurs during X-cutter position detection?	See 7 Abnormal X-cutter operation.			

Problem	Check Item	Cause	Remedy	Repair	See Section
d. Abnormal Y-carriage power ON processing	Sensor lever cuts photosensor at start position?	Deformed sensor frame unit?	Replace the sensor frame unit.		3.3.3
	Photosensor cut off when not at start position?	Sensor lever incorrectly installed.			3.3.4
		Defective sensor lever.	Replace the sensor lever.		3.3.5
	Error during Y-carriage position detection?	See 9 Document width cannot be detected correctly.			
e. Abnormal Y-cutter power ON processing	Error during Y-cutter position detection?	See 11 No cutting in Y direction.			

- 4** An error occurred during processing after power ON (after film feed).
- a. Defective film or cartridge.
 - b. Defective film feed detector (TPS) switch.
 - c. Defective film feed system.

Problem	Check Item	Cause	Remedy	Repair	See Section	
a. Defective film or cartridge	Is the film cartridge correctly mounted?	Defective film cartridge mounting.	Correctly mount the film cartridge.		3.2	
	Does film remain in the cartridge?	No film remaining.	Replace the film.			
	Is the cartridge deformed or cracked?	Defective cartridge.	Replace the cartridge.			
b. Defective film feed detector (TPS) switch.	Is the orange lead connector connected to CN15 on the Main PCB?	Leaf switch assy not connected.	Correctly connect the leaf switch assy.		3.3.3 3.3.4 3.3.5	
	Does the sensor lever press the film feed detector (TPS) switch (leaf switch F assy) when film is inserted?	Incorrectly installed leaf switch.	Correctly install the leaf switch.		3.3.1 3.3.3 3.3.4	
		Is the leaf switch open when no film is inserted?	Incorrectly installed sensor lever.	Correctly install the sensor lever.		3.3.5 3.4
	Is main CPU port P60 (Pin 56) at High level when leaf switch TPS is open?	Defective sensor lever.	Replace the sensor lever.			3.12.2
		Continuity problem in Main PCB.	Replace Main PCB assy.			3.3.3 3.3.4
	When leaf switch TPS is shorted, is CN15 on the Main PCB shorted?	Defective pull-up resistor R41.	Replace Main PCB assy.	Replace R41.		3.3.5 3.5.1
		Defective leaf-switch F assy.	Replace leaf-switch F assy.			3.3.1 3.3.3 3.3.4 3.3.5 3.4 3.12.2
	Is main CPU port P60 (Pin 56) at Low level when CN15 on the Main PCB is shorted?	Continuity problem in Main PCB.	Replace Main PCB assy.			3.3.3
		Defective series resistor R35.	Replace Main PCB assy.	Replace R35.		3.3.4 3.3.5
		Defective main CPU#1.	Replace Main PCB assy.	Replace CPU#1.		3.5.1
c. Defective film feed system	Defective film feed (LF) motor.	See 5 Abnormal manual feed .				
	Defective film compression system.					

5 Abnormal manual feed

- a. Defective film feed (LF) motor.
- b. Defective film compression system.
- c. Problem related to paper eject roller.

Problem	Check Item	Cause	Remedy	Repair	See Section
a. Defective film feed (LF) motor	Is the black lead connector connected to CN10 on the Main PCB?	Motor harness assy not connected.	Correctly connect the motor harness assy.		3.3.3 3.3.4 3.3.5
	Are pulses output from output ports P70 to P73 (Pin 1 to Pin 4) of the main CPU#1?	Defective main CPU#1.	Replace Main PCB assy.	Replace CPU#1.	3.3.3 3.3.4 3.3.5 3.5.1
	When the output from output ports P70 to P73 (Pin 1 to Pin 4) of the main CPU#1 is Low, is the output from transistor array QA2 Low?	Defective transistor array QA2.	Replace Main PCB assy.	Replace QA2.	
	Is +24V DC applied to Pins 3 and 4 of connector CN10 on the Main PCB?	Continuity problem in Main PCB.	Replace Main PCB assy.		
	Continuity in motor harness assy?	Defective motor harness assy.	Replace motor harness assy for LF motor.		3.3.1 3.3.3
	Correct resistance value (approx. 38 ohms) between each phase of the LF motor (LF motor) and the COM pin?	Defective LF motor.	Replace LF motor.		3.3.4 3.3.5 3.4 3.14.2
b. Defective film compression system.	Are top and bottom feed rollers correctly engaged?	Roller holder unit is incorrectly set up.	Correctly set up the roller holder unit.		6.2
	Is film correctly placed between the feed rollers?	Defective cassette setting.	Set the cassette correctly.		
c. Problem related to paper eject roller	Film or other foreign matter stuck to top or bottom paper eject roller.	Foreign matter stuck to roller.	Clean off foreign matter.		3.3.1 3.3.3 3.3.4
	Do the top and bottom paper eject rollers move smoothly?	Problem with paper eject rollers.	Apply KS64F silicon grease to the four bearings.		3.3.5 3.4

6 Abnormal trimming

- a. Defective trimming (TRI) switch.
- b. Defective trimming (TC) motor.
- c. Defective trimming (TRG) switch.
- d. Defective T-cutter.

Problem	Check Item	Cause	Remedy	Repair	See Section
a. Defective trimming (TRI) switch	Is document correctly inserted?	Document inserted incorrectly.	Correctly insert the document.		
	Does the sensor lever press the trimming switch (leaf switch TRI assy) when a document is inserted? Is the leaf switch open when no document is inserted?	Incorrectly installed trimming switch.	Correctly install the trimming switch.		3.3.1 3.3.3 3.3.4
		Incorrectly installed sensor lever. Defective sensor lever.	Correctly install the sensor lever. Replace the sensor lever.		3.3.5 3.4 3.6
	Is the black lead connector connected to CN5 on the Main PCB?	Leaf switch assy not connected.	Correctly connect the leaf switch assy.		3.3.3 3.3.4 3.3.5
	Is main CPU port P40 (Pin 41) at High level when trimming switch TRI is open?	Continuity problem in Main PCB.	Replace Main PCB assy.		3.3.3 3.3.4 3.3.5 3.5.1
		Defective pull-up resistor R24.	Replace Main PCB assy.	Replace R24.	
	When trimming switch TRI is shorted, is CN5 on the Main PCB shorted?	Defective trimming-switch TRI assy.	Replace trimming-switch TRI assy.		3.3.1 3.3.3 3.3.4 3.3.5 3.4 3.6
	Is main CPU port P40 (Pin 41) at Low level when CN5 on the Main PCB is shorted?	Continuity problem in Main PCB.	Replace Main PCB assy.		3.3.3 3.3.4 3.3.5 3.5.1
		Defective series resistor R30.	Replace Main PCB assy.	Replace R30.	
	When main CPU port P40 (Pin 41) is at Low level, is this recognized by the main CPU?	Defective main CPU#1.	Replace Main PCB assy.	Replace CPU#1.	

Problem	Check Item	Cause	Remedy	Repair	See Section
b. Defective trimming (TC) motor.	Is the white lead connector connected to CN9 on the Main PCB?	Motor harness assy not connected.	Correctly connect the motor harness assy.		3.3.3 3.3.4 3.3.5
	Are pulses output from output ports P74 to P77 (Pin 5 to Pin 8) of the main CPU#1?	Defective main CPU#1.	Replace Main PCB assy.	Replace CPU#1.	3.3.3 3.3.4 3.3.5 3.5.1
	When the output from output ports P74 to P77 (Pin 5 to Pin 8) of the main CPU#1 is Low, is the output from transistor array QA1 Low?	Defective transistor array QA1.	Replace Main PCB assy.	Replace QA1.	
	Is +24V DC applied to Pins 3 and 4 of connector CN9 on the Main PCB?	Continuity problem in Main PCB.	Replace Main PCB assy.		
	Continuity in motor harness assy?	Defective motor harness assy.	Replace motor harness assy for TC motor.		3.3.1 3.3.3 3.3.4 3.3.5 3.4
	Correct resistance value (approx. 43 ohms) between each phase of the TC motor and the COM pin?	Defective TC motor.	Replace TC motor.		3.3.1 3.3.3 3.3.4 3.3.5 3.4 3.15
c. Defective trimming (TRG) switch.	Is the red lead connector connected to CN6 on the Main PCB?	Leaf switch assy not connected.	Correctly connect the leaf switch assy.		3.3.3 3.3.4 3.3.5
	Is main CPU port P44 (Pin 45) at High level when leaf switch TR-G is open?	Continuity problem in Main PCB.	Replace Main PCB assy.		3.3.3 3.3.4 3.3.5
		Defective pull-up resistor R25.	Replace Main PCB assy.	Replace R25.	3.5.1
	When leaf switch TR-G is shorted, is CN6 on the Main PCB shorted?	Defective leaf-switch TR-G assy.	Replace leaf-switch TR-G assy.		3.3.1 3.3.3 3.3.4 3.3.5 3.4 3.6
	Is main CPU port P44 (Pin 45) at Low level when CN6 on the Main PCB is shorted?	Continuity problem in Main PCB.	Replace Main PCB assy.		3.3.3
		Defective series resistor R29.	Replace Main PCB assy.	Replace R29.	3.3.4 3.3.5
	When main CPU port P44 (Pin 45) is at Low level, is this recognized by the main CPU?	Defective main CPU#1.	Replace Main PCB assy.	Replace CPU#1.	3.5.1

Problem	Check Item	Cause	Remedy	Repair	See Section
d. Defective T-cutter.	Does the trimming T-cam rotate when the trimming motor (TC motor) rotates?	Problem with planet gear operation.	Apply KS64F silicon grease to the four bearings. Replace the TY planet gear.		3.3.1 3.3.3 3.3.4 3.3.5 3.4 3.15
	No cutting occurs despite a grating noise is heard?	The T-cutter plate is not installed.	Install a T-cutter plate.		3.3.1 3.3.3
		The T-cutter plate is not installed correctly.	Correctly install the T-cutter plate.		3.3.4 3.3.5
Cutting position is correct but cutting is incomplete?	Defective T-cutter plate.	Replace the T-cutter plate.		3.4 3.6	

7 Abnormal X-cutter operation.

- a. Defective X-cutter position switch.
- b. Defective X-cutter DC motor.
- c. Defective X-cutter.

Problem	Check Item	Cause	Remedy	Repair	See Section
a. Defective X-cutter position switch	The X-cutter rotary cutter is at the left or right end but neither Pin 2 nor 3 is continuous with Pin 1? Alternatively, both Pin 2 and 3 are continuous with Pin 1?	Defective X-cutter unit.	Replace the X-cutter unit.		3.3.1 3.3.3 3.3.4 3.3.5 3.4 3.6.1 3.7.1 3.8.1 3.8.2 3.10 3.11.1 3.12.1
	Continuity between Pins 1, 2, and 3 of the X-cutter harness assy?	Defective X-cutter harness assy.	Replace the X-cutter harness assy.		3.3.1 3.3.3 3.3.4 3.3.5 3.4
	During X-cutter operation, do main CPU port P53 (Pin 52) and port P54 (Pin 53) switch to High level?	Defective pull-up resistors R20 and R22.	Replace Main PCB assy.	Replace R20 and R22.	3.3.3 3.3.4
	When main CPU port P53 (Pin 52) and port P54 (Pin 53) are at Low level, is this recognized by the main CPU?	Defective main CPU#1.	Replace Main PCB assy.	Replace CPU#1.	3.3.5 3.5.1
b. Defective X-cutter DC motor	When output is normal from the main CPU#1 output ports P15 to P17 (Pin 22 to Pin 24 [See Table 5.5-1]), does the output between OUT1 (Pin 1) and OUT2 (Pin 3) of the DC motor driver #4 changes alternatively between 0 V and +24 V?	Defective DC motor driver #4.	Replace Main PCB assy.	Replace #4.	3.3.3 3.3.4 3.3.5 3.5.1
	Continuity between Pins 4 and 5 of the X-cutter harness assy?	Defective X-cutter harness assy.	Replace the X-cutter harness assy.		3.3.1 3.3.3 3.3.4 3.3.5 3.4
	Normal resistance (approx. 30 ohms) between Pins 4 and 5 of the X-cutter harness assy (DC motor resistance value)?	Defective X-cutter unit.	Replace the X-cutter unit.		3.3.1 3.3.3 3.3.4 3.3.5 3.4 3.6.1
c. Defective X-cutter.	Does the rotary cutter rotate when the DC motor rotates?	Defective X-cutter unit.	Replace the X-cutter unit.		3.7.1 3.8.1 3.8.2
	Cutting of only halfway?	Defective X-cutter unit.	Replace the X-cutter unit.		3.10 3.11.1 3.12.1
		Metal or other foreign matter in the laminated document.	Remove the foreign matter.		3.3.1 3.3.3 3.3.4 3.3.5 3.4

8 Document cannot be correctly inserted.

- a. Problem with input-side rollers.
- b. Defective PE sensor (P-END) switch.

Problem	Check Item	Cause	Remedy	Repair	See Section
a. Problem with input-side rollers	Is document correctly inserted against the paper feed roller?	Document inserted incorrectly.	Correctly insert the document.		—
	Is document correctly aligned at right edge?	Document inserted incorrectly.	Correctly insert the document.		—
	Is document inserted at an slant?	Defective paper feed roller extension springs.	Correctly install extension springs.		3.3.1 3.3.3 3.3.4 3.3.5 3.4
		Are the paper reference in the body cover and paper feed roller perpendicular?	Re-adjust.		6.3.3
b. Defective PE sensor (P-END) switch	Does the sensor lever press the PE sensor (P-END) switch when a document is inserted? Is the PE sensor (P-END) switch OFF when no document is inserted?	Incorrectly installed PE sensor.	Correctly install the PE sensor.		3.3.3 3.3.4 3.3.5
		Incorrectly installed sensor crank.	Correctly install the sensor crank.		
		Defective sensor crank.	Replace the sensor crank.		
	Is the white lead harness assy connected to the PE sensor connector?	Defective harness assy connection.	Correctly connect the harness assy.		
	Is the white lead connector connected to CN7 on the Main PCB?	Defective harness assy connection.	Correctly connect the harness assy.		
	Is main CPU port P45 (Pin 46) at High level when PE sensor P-END is OFF?	Continuity problem in Main PCB.	Replace Main PCB assy.		3.3.3 3.3.4 3.3.5 3.5.1
		Defective pull-up resistor R32.	Replace Main PCB assy.	Replace R32.	
	When paper sensor P-END is ON, is CN7 on the Main PCB shorted?	Defective PE sensor assy.	Replace PE sensor assy.		3.3.3 3.3.4 3.3.5
		Defective harness assy.	Replace the paper sensor harness assy.		
	Is main CPU port P45 (Pin 46) at Low level when CN7 on the Main PCB is shorted?	Continuity problem in Main PCB.	Replace Main PCB assy.		3.3.3 3.3.4 3.3.5 3.5.1
Defective series resistor R28.		Replace Main PCB assy.	Replace R28.		
When main CPU port P45 (Pin 46) is at Low level, is this recognized by the main CPU?	Defective main CPU#1.	Replace Main PCB assy.	Replace CPU#1.		

9 Document width cannot be detected correctly.

- a. Defective Y-carriage (Y-CA) motor.
- b. Defective sensor unit (YCA-F).
- c. Defective Y-cutter arm.

Problem	Check Item	Cause	Remedy	Repair	See Section
a. Defective Y-carriage (Y-CA) motor	Is the Y-CA motor harness connected to connector C11 on the Main PCB?	Motor harness not connected.	Correctly connect the motor harness.		3.3.3 3.3.4 3.3.5
	Are pulses output from output ports P00 to P03 (Pin 9 to Pin 12) of the main CPU#1?	Defective main CPU#1.	Replace Main PCB assy.	Replace CPU#1.	3.3.3 3.3.4 3.3.5 3.5.1
	When the output from output ports P00 to P03 (Pin 9 to Pin 12) of the main CPU#1 is High, is the output from transistor array QA3 Low?	Defective transistor array QA3.	Replace Main PCB assy.	Replace QA3.	
	When output port P65 (Pin 61) of the main CPU#1 is High (equal or more than 4V), is +24V DC applied to Pin 5 of connector CN11?	Defective transistor Q4.	Replace Main PCB assy.	Replace Q4.	
		Defective transistor Q3.	Replace Main PCB assy.	Replace Q3.	
		Continuity problem in Main PCB.	Replace Main PCB assy.		
	Correct resistance value (approx. 227 ohms) between each phase of the Y-CA motor and the COM pin?	Defective Y-CA motor.	Replace the Y-CA motor.		
b. Defective sensor unit (YCA-F).	Is the flat cable connected to connector CN2 (CN14) on the Main PCB?	Defective connection of the flat cable.	Correctly connect the flat cable.		3.3.3 3.3.4 3.3.5
	Sensor lever cuts photosensor when a document is inserted?	Sensor lever incorrectly installed.	Correctly install the sensor lever.		3.3.3 3.3.4 3.3.5 3.8
	Photosensor cut off when no document is inserted?	Defective sensor lever.	Replace the sensor lever.		
	Is photosensor PH2 on the Paper size detector PCB working correctly?	Defective photosensor PH2.	Replace the Paper size detector PCB.	Replace PH2.	
	Normal continuity in Paper size detector PCB flat cable?	Discontinuity in flat cable.	Replace the Paper size detector PCB.	Replace the sensor harness 550X4.	
c. Defective Y-cutter arm	Does the Y-cutter arm move when the Y-CA motor rotates?	Y-cutter arm and timing belt incorrectly installed.	Correctly install the timing belt.		
	Y-cutter arm is caught during its movement?	Foreign matter stuck to the sensor arm.	Clean off the foreign matter.		3.3.4 3.3.5
	Is the Y-cutter arm separated from the sensor frame?	The Y-cutter arm shaft is incorrectly installed.	Correctly install the Y-cutter arm shaft.		

10 Lamination is not normal.

- a. Defective film type (ENC) detector.
- b. Defective document or film.

Problem	Check Item	Cause	Remedy	Repair	See Section
a. Defective film type (ENC) detector.	Is the white lead connector connected to CN3 on the Main PCB?	Defective harness assy connection.	Correctly connect the harness assy.		3.3.3 3.3.4
	Is the white lead harness assy connected to the ENC sensor assy?	Defective harness assy connection.	Correctly connect the harness assy.		3.3.1 3.3.3
	Is the ENC sensor assy correctly installed on the cassette holder?	Incorrectly installed ENC sensor assy.	Correctly install the ENC sensor assy.		3.3.4 3.3.5 3.4
	Continuity in ENC harness assy?	Defective ENC harness assy.	Replace the ENC harness assy.		3.6.1 3.7.1
	When the output from output port P30 (Pin 33) of the main CPU#1 is Low, does the output from CN3 Pin 2 vary between 0 and 4V DC due to black and silver targets?	Defective photosensor in ENC sensor assy.	Replace ENC sensor assy.	Replace the photosensor.	3.8.1 3.8.2 3.9 3.10 3.11.1 3.12.1 3.13.1
		ENC sensor assy incorrectly adjusted.	Replace ENC sensor assy.		3.16
	When a signal is input to CN3 Pin 2, does the signal change at output port TC1 (Pin 19) of the main CPU?	Defective IC#5.	Replace Main PCB assy.	Replace IC#5.	3.3.3
		Defective R47.	Replace Main PCB assy.	Replace R47.	3.3.4 3.3.5
		Continuity problem in Main PCB.	Replace Main PCB assy.		3.5.1
	b. Defective document or film	Is a cartridge mounted?	No cartridge mounted.	Mount a cartridge.	
Does film remain in the cartridge?		No film remaining.	Replace the film.		
Is silver-black foil stuck to the edge of the film?		Defective film.	Replace the film.		

11 No cutting in Y direction.

- a. Defective Y-cutter (Y-G) switch.
- b. Abnormal Y-cutter vertical movement.

Problem	Check Item	Cause	Remedy	Repair	See Section	
a. Defective Y-cutter (Y-G) switch	Is the blue lead connector connected to CN8 on the Main PCB?	Leaf-switch assy not connected correctly.	Correctly connect the leaf-switch assy.		3.3.3 3.3.4 3.3.5	
	Is leaf switch Y-G not contacted when the Y-cutter is at the standby position?	Leaf switch incorrectly installed.	Correctly install the leaf switch.		3.3.1 3.3.3 3.3.4 3.3.5 3.4	
		Y-sensor lever incorrectly installed.	Correctly install the Y-sensor lever.		3.3.1 3.3.3 3.3.4 3.3.5 3.4	
	Does the Y-sensor lever press the leaf switch when Y-cutter is not at the standby position?	Defective Y-sensor lever.	Replace the Y-sensor lever.		3.6.1 3.7.1 3.8.1 3.8.2 3.10	
		Is main CPU port P46 (Pin 47) at High level when leaf switch Y-G is open?	Continuity problem in Main PCB.	Replace Main PCB assy.		3.3.3 3.3.4 3.3.5 3.5.1
	When leaf switch Y-G is shorted, is CN8 on the Main PCB shorted?	Defective pull-up resistor R31.	Replace Main PCB assy.	Replace R31.		3.3.1 3.3.3 3.3.4 3.3.5 3.4
		Defective leaf switch assy.	Replace leaf switch Y assy.			
	Is main CPU port P46 (Pin 47) at Low level when CN8 on the Main PCB is shorted?	Continuity problem in Main PCB.	Replace Main PCB assy.			3.3.3
		Defective series resistor R27.	Replace Main PCB assy.	Replace R27.		3.3.4 3.3.5
		When main CPU port P46 (Pin 47) is at Low level, is this recognized by the main CPU?	Defective main CPU#1.	Replace Main PCB assy.	Replace CPU#1.	
b. Abnormal Y-cutter vertical movement	Does the Y-cutter cam rotate when the trimming motor (TC motor) rotates?	Problem with planet gear operation.	Apply KS64F silicon grease to the four bearings. Replace the TY planet gear.		3.3.1 3.3.3 3.3.4	
	Does the Y-diversion lever rotate when the Y-cutter cam rotates?	Y-extension springs L/R incorrectly installed.	Correctly install Y-extension springs L/R.		3.3.5 3.4 3.15	
		Foreign matter under the Y-diversion lever	Clean out foreign matter.			
Is Y-cutter assy mounted correctly?	Incorrectly mounted Y-cutter assy.	Mount the Y-cutter assy correctly.			---	

12 Incorrect cutting in Y direction.

- a. Incorrect Y-direction cutting position.
- b. Defective Y-cutter.

Problem	Check Item	Cause	Remedy	Repair	See Section
a. Incorrect Y-direction cutting position	Does the right cutter move when the mode is changed?	Y-cutter guide R and slide plate 2 incorrectly installed.	Correctly reassemble the body cover.		3.3.3 3.3.4
	Does the Y-cutter move when the Y-carriage moves?	Y-cutter arm L and Y-cutter guide L incorrectly installed.	Correctly reassemble Y-cutter arm L.		3.3.5
	Right cut position is always displaced in one direction.	Incorrect adjustment of slide plates 1 and 2.	Readjust.		6.3.1
	Left cut position is always displaced in one direction.	Incorrect adjustment of Y-sensor unit.	Readjust the Y-sensor unit.		6.3.2
	Does Y-cutter arm move smoothly?	Defective Y-cutter arm movement.	Apply KS64F silicon grease to Y-cutter arm shaft and sensor frame.		3.3.1 3.3.3 3.3.4 3.3.5 3.4
b. Defective Y-cutter	Is the Y-cutter unit correctly installed?	Incorrectly installed Y-cutter unit.	Correctly install the Y-cutter unit.		3.11.1
	Y-cutter makes jagged cuts?	Defective Y-cutter unit.	Replace Y-cutter unit.		

13 Incorrect cutting position at document front or rear edge.

- a. Defect in paper feed system.
- b. Defect in paper sensor system.

Problem	Check Item	Cause	Remedy	Repair	See Section
a. Defect in paper feed system	Do the three planet gear units mounted on chassis L move smoothly?	Defective operation of planet gear units.	Apply KS64F silicon grease to the planet gear units. Replace the planet gear units.		3.3.1 3.3.3 3.3.4 3.3.5 3.4 3.14.1
	Does the rollers slip?	Dirt or other foreign matter stuck to rollers.	Clean the rollers.		—
	Is LF motor out of step?	Defective driving roller shaft.	Apply KS64F silicon grease to the driving roller shaft bearings.		3.3.1 3.3.3 3.3.4 3.3.5 3.4
b. Defect in paper sensor system	Does the paper sensor work smoothly?	Defective paper sensor.	Replace the paper sensor.		3.3.3
	Deformed sensor lever (paper sensor crank)?	Defective paper sensor crank.	Replace the paper sensor crank.		3.3.4 3.3.5
	Does the sensor lever work smoothly?	Defective paper sensor crank.	Replace the paper sensor crank.		

14 Cartridge size, film type cannot be detected correctly.

a. Defective cartridge type detector (CSIZE) switch.

Problem	Check Item	Cause	Remedy	Repair	See Section
a. Defective cartridge type detector (CSIZE) switch	Is the yellow lead connector connected to CN12 on the main PCB?	Leaf switch C Assy not connected.	Correctly connect the leaf switch C Assy.		3.3.3 3.3.4 3.3.5
	Is the cartridge leaf switch pressed when an A4 cartridge is inserted?	Incorrectly installed leaf switch C Assy.	Correctly install the leaf switch C Assy.		3.3.1 3.3.3 3.3.4 3.3.5 3.4
		Incorrectly inserted cartridge?	Re-insert the cartridge.		6.2
	Is the cartridge leaf switch not pressed when an A6 cartridge is inserted?	Incorrectly installed leaf switch C Assy.	Correctly install the leaf switch C Assy.		3.3.1 3.3.3 3.3.4 3.3.5 3.4
	Is main CPU port P62 (Pin 58) at High level when leaf switch CSIZE is open?	Continuity problem in Main PCB.	Replace Main PCB Assy.		3.3.3 3.3.4 3.3.5
		Defective pull-up resistor R77.	Replace Main PCB Assy.	Replace R77.	3.5.1
	When leaf switch CSIZE is shorted, is CN12 on the Main PCB shorted?	Defective leaf switch C Assy.	Replace leaf switch C Assy.		3.3.1 3.3.3 3.3.4 3.3.5 3.4
	Is main CPU port P62 (Pin 58) at Low level when CN12 on the Main PCB is shorted?	Continuity problem in Main PCB.	Replace Main PCB Assy.		3.3.3
		Defective series resistor R42.	Replace Main PCB Assy.	Replace R42.	3.3.4 3.3.5
	When main CPU port P62 (Pin 58) is at Low level, is this recognized by the main CPU?	Defective main CPU#1.	Replace Main PCB Assy.	Replace CPU#1.	3.5.1

15 Buzzer does not sound.

a. Defective buzzer circuit.

Problem	Check Item	Cause	Remedy	Repair	See Section
a. Defective buzzer circuit	Are 4kHz pulses output from DV0 (20 pin) on main CPU#1?	Defective main CPU#1.	Replace Main PCB assy.	Replace CPU#1.	3.3.3
	Are correct voltages applied across buzzer BZ1?	Defective resistors R82 and R83.	Replace Main PCB assy.	Replace R82 and R83.	3.3.4 3.3.5
	Buzzer BZ1 does not sound?	Defective buzzer BZ1.	Replace Main PCB assy.	Replace BZ1.	3.5.1

brother®

May, 2000
86S004BE3
Printed in Japan