



## *Service Manual*

**Color Jetprinter™ 1020**

**4078-00X**

- ***Table of Contents***
- ***Start Diagnostics***
- ***Safety and Notices***
- ***Trademarks***
- ***Index***
- ***Manuals Menu***

**LEXMARK™**

*Lexmark and Lexmark with diamond design are trademarks of Lexmark International, Inc., registered in the United States and/or other countries.*

**Second Edition (July, 1996)**

The following paragraph does not apply to the United Kingdom or any country where such provisions are inconsistent with local law: LEXMARK INTERNATIONAL, INC. PROVIDES THIS PUBLICATION "AS IS" WITHOUT WARRANTY OF ANY KIND, EITHER EXPRESS OR IMPLIED, INCLUDING, BUT NOT LIMITED TO, THE IMPLIED WARRANTIES OF MERCHANTABILITY OR FITNESS FOR A PARTICULAR PURPOSE. Some states do not allow disclaimer of express or implied warranties in certain transactions, therefore, this statement may not apply to you.

This publication could include technical inaccuracies or typographical errors. Changes are periodically made to the information herein; these changes will be incorporated in later editions of the publication. Improvements or changes in the products or the programs described in this publication may be made at any time. Publications are not stocked at the address given below; requests for publications should be made to your point of purchase.

Comments may be addressed to Lexmark International, Inc., Department D22A/035-3, 740 New Circle Road, Lexington, Kentucky 40550, U.S.A. Lexmark may use or distribute any of the information you supply in any way it believes appropriate without incurring any obligation to you.

Lexmark is a trademark of Lexmark International, Inc., registered in the United States and/or other countries.

Color Jetprinter is a trademark of Lexmark International, Inc.

Other trademarks are the property of their respective owners.

**© Copyright Lexmark International, Inc. 1995, 1996. All Rights Reserved.**

**UNITED STATES GOVERNMENT RESTRICTED RIGHTS**

This software and documentation are provided with RESTRICTED RIGHTS. Use, duplication or disclosure by the Government is subject to restrictions as set forth in subparagraph (c)(1)(ii) of the Rights in Technical Data and Computer Software clause at DFARS 252.227-7013 and in applicable FAR provisions: Lexmark International, Inc., Lexington KY 40550.

# Contents

<b>Preface</b> .....	<b>v</b>
Safety Information.....	v
<b>General Information</b> .....	<b>1-1</b>
Power Consumption .....	1-1
Maintenance Approach.....	1-1
Abbreviations .....	1-2
Unique Tools Required For Service .....	1-2
<b>Diagnostic Information</b> .....	<b>2-1</b>
Start .....	2-1
Error Indicator Table.....	2-2
Power-On Self Test (POST) Sequence .....	2-2
POST Symptom Table .....	2-3
Symptom Tables .....	2-4
Service Checks.....	2-6
Carrier Transport Service Check .....	2-6
Envelope Feed Service Check.....	2-7
Maintenance Station Service Check .....	2-8
Paper Feed Service Check .....	2-9
Paper Path Service Check .....	2-11
Parallel Port Service Check .....	2-12
Power Service Check.....	2-12
Print Quality Service Check .....	2-13
Print Quality Notice.....	2-15
<b>Diagnostic Aids</b> .....	<b>3-1</b>
EOF and Home Position Sensors Test.....	3-2
Initialize Error Log.....	3-3
Parallel Port Test .....	3-4
Print NVRAM Contents .....	3-5
Reset NVRAM to EMEA Defaults .....	3-6
Reset NVRAM to USA Defaults .....	3-7
Test Page .....	3-8

<b>Repair Information</b> .....	<b>4-1</b>
Handling ESD-Sensitive Parts .....	4-1
Adjustments .....	4-2
Removal Procedures .....	4-2
Releasing Plastic Latches .....	4-2
Access Cover Removal .....	4-3
Base Assembly Removal .....	4-3
Carrier Belt Removal .....	4-3
Carrier Frame Assembly Removal .....	4-4
Carrier Home Sensor Removal .....	4-4
Carrier Transport Motor Removal .....	4-5
Drive Train Assembly Removal .....	4-5
Front Cover Removal .....	4-6
Gutter Pad Removal .....	4-6
Large Feed Roll Removal .....	4-7
Maintenance Station Assembly Removal .....	4-7
Maintenance Wiper and Cap Removal .....	4-7
Mid Frame Assembly Removal .....	4-8
Paper Feed Motor Removal .....	4-8
Power Supply Removal .....	4-8
Printhead Carrier Assembly Removal .....	4-9
Rear Cover Removal .....	4-10
Sheet Feeder Removal .....	4-11
Small Feed Roll Assembly Removal .....	4-11
Small Feed Roll Bracket Assembly Removal .....	4-12
System Board Removal .....	4-13
<b>Connector Locations</b> .....	<b>5-1</b>
System Board Connectors .....	5-1
<b>Preventive Maintenance</b> .....	<b>6-1</b>
Lubrication Specifications .....	6-1
<b>Parts Catalog</b> .....	<b>7-1</b>
How To Use This Parts Catalog .....	7-1
Assembly 1: Covers .....	7-2
Assembly 2: Paper Feed / Carrier Transport / Maintenance .....	7-4
Assembly 3: Electronics .....	7-6
Assembly 3: Electronics (Continued) .....	7-8
Assembly 4: Carrier .....	7-10
Assembly 5: Sheet Feeder .....	7-12
<b>Index</b> .....	<b>X-1</b>

---

## Preface

This manual is divided into the following chapters:

1. **General Information** contains a general description of the printer and the maintenance approach used to repair it. Special tools and test equipment are listed in this chapter, as well as general environmental and safety instructions.
2. **Diagnostic Information** contains error indicator table, symptom table, and service checks used to isolate failing field replaceable units (FRUs).
3. **Diagnostic Aids** contains tests and checks used to locate or repeat symptoms of printer problems.
4. **Repair Information** provides instructions for making printer adjustments and removing and installing FRUs.
5. **Connector Locations** uses illustrations to identify the connector locations and test points on the printer.
6. **Preventive Maintenance** contains the lubrication specifications and recommendations to prevent problems.
7. **Parts Catalog** contains illustrations and part numbers for individual FRUs.

---

## Safety Information

- The maintenance information for this product has been prepared for use by a professional service person and is not intended to be used by others.
- There may be an increased risk of electric shock and personal injury during disassembly and servicing of this product. Professional service personnel should understand this and take necessary precautions.
- The safety features of some parts may not always be obvious. Therefore, replacement parts must have the identical or equivalent characteristics as the original parts.

## Sicherheitshinweise

- Die Wartungsinformationen für dieses Produkt wurden zur Verwendung durch einen Wartungsfachmann entwickelt und sollten nicht von anderen benützt werden.
- Zusätzliches Risiko eines elektrischen Schlags und körperlicher Verletzung existiert während des Auseinandernehmens und der Wartung des Geräts. Fachpersonal sollte im vollen Verständnis der Lage entsprechende Vorsichtsmaßnahmen ergreifen.
- Ersatzteile müssen gleiche oder gleichwertige Merkmale wie die Originalteile aufweisen, da Sicherheitsvorkehrungen nicht immer offensichtlich sind.

## Consignes de Sécurité

- Les consignes d'entretien et de réparation de ce produit s'adressent uniquement à un personnel de maintenance qualifié.
- Le démontage et l'entretien de ce produit pouvant présenter certains risques électriques, le personnel d'entretien qualifié devra prendre toutes les précautions nécessaires.
- Les normes de sécurité de certaines pièces n'étant pas toujours explicites, les pièces de rechange doivent être identiques ou conformes aux caractéristiques des pièces d'origine.

## Norme di sicurezza

- Le informazioni riguardanti la manutenzione di questo prodotto sono indirizzate soltanto al personale dell'assistenza autorizzato.
- Durante lo smontaggio e il manutenzionamento di questo prodotto, è possibile il rischio accresciuto di scosse elettriche e danni personali. Il personale di assistenza autorizzato, consapevole di ciò, deve adottare le precauzioni necessarie.
- È possibile che le funzioni di sicurezza di alcuni elementi non siano così ovvie, quindi, i pezzi di ricambio devono avere caratteristiche identiche o equivalenti a quelle dei pezzi originali.

## **Pautas de Seguridad**

- La información sobre el mantenimiento de este producto fue escrita para el personal de mantenimiento cualificado y no para cualquier otro usuario.
- Existen mayores riesgos de descargas eléctricas y daños personales durante el desmontaje y la reparación de la máquina. El personal cualificado comprende esto y toma las precauciones necesarias.
- Los dispositivos de seguridad de algunas partes quizá no siempre puedan ser reconocidas a simple vista. Por lo tanto, las partes de reemplazo deben poseer características idénticas o equivalentes a las partes originales.

## **Sikkerhedsoplysninger**

- Oplysningerne om vedligeholdelse af dette produkt er forberedt med henblik på professionelt servicepersonale, og bør derfor ikke benyttes af andre.
- Risikoen for elektrisk stød øges under demontering og service af dette produkt, hvorfor der bør tages de nødvendige forholdsregler.
- Sikkerhedsforanstaltningerne er ikke altid lige åpenbare for alle reservedele. Der bør derfor kun anvendes originale reservedele eller reservedele med samme egenskaber som de oprindelige.

## **Informações de Segurança**

- As informações de segurança relativas a este produto destinam-se a profissionais destes serviços e não devem ser utilizadas por outras pessoas.
- Risco de choques eléctricos e ferimentos graves durante a desmontagem e manutenção deste produto. Os profissionais destes serviços devem estar avisados deste facto e tomar os cuidados necessários.
- Os dispositivos de segurança de algumas peças poderão não ser sempre suficientemente evidentes. Assim, as peças sobressalentes devem possuir características idênticas ou equivalentes às peças originais.

## Chinese Safety Information

### 安全资讯

- 本产品的维护资讯仅供专业服务人员使用，而非供一般人使用。
- 本产品在拆卸、维修的时候，发生电击、人员受伤的危险性会增加。专业服务人员对这点应有事先的了解，并采取必要的安全措施。
- 有些零件的安全功能有时可能不明显。因此，替换零件的特性一定要与原有的零件一致。

## Korean Safety Information

### 안전 사항

- 본 제품에 관한 유지 보수 설명서는 전문 서비스 기술자용으로 작성된 것이므로 비 전문가는 사용할 수 없습니다.
- 본제품을 해체하거나 정비할 경우 전기적인 충격을 받거나 상처를 입을 위험이 커집니다. 전문 서비스 기술자는 이 사실을 숙지하고 필요한 예방 조치를 취하도록 하십시오.
- 일부 부품의 안전성은 항상 보장되지 않습니다. 따라서, 교체 부품은 원래 부품과 같거나 동등한 특성을 가진 제품을 사용하여야합니다.



---

## 1. General Information

The Color Jetprinter™ 1020 printer is a personal, near laser-quality inkjet printer. The print cartridge is a single-unit customer replaceable supply item. A single printhead provides three colors and composite black printing. The printer also supports a black print cartridge and provides 600 X 300 dpi edge definition for professional quality text image and graphics printing.

---

### Power Consumption

- Less than 2 Watts - power off and power to the printer
- 7.5 Watts - Idle Mode (power on - not printing)
- 12 Watts - Printing (average)
- 25 Watts - Printing (peak)

---

### Maintenance Approach

The diagnostic information in this manual leads you to the correct field replaceable unit (FRU) or part. Use the error code charts, symptom index, service checks, and diagnostic aids to determine the symptom and repair the failure. Begin with **“Start” on page 2-1**.

This printer can be serviced without being connected to a host computer. The user is directed, in the Printer Control program, to perform the bidirectional alignment adjustments after replacing a print cartridge.

After you complete the repair, perform tests as needed to verify the repair.

## **Abbreviations**

ESD	Electrostatic Discharge
FRU	Field Replaceable Unit
HVPS	High Voltage Power Supply
LVPS	Low Voltage Power Supply
NVRAM	Nonvolatile Random Access Memory
OEM	Original Equipment Manufacturer
POST	Power-On Self Test
V ac	Volts alternating current
V dc	Volts direct current
ZIF	Zero Insertion Force

## **Unique Tools Required For Service**

Parallel Wrap Plug P/N 1319128

---

## 2. Diagnostic Information

Use the error indicator table, symptom tables, service checks, and diagnostic aids in chapter 3, to determine the failing part.

---

### Start

Service error indications show as a series of flashes of the Power On light. There is a pause between each series of flashes. If your machine has an error indication, locate the series of flashes in the **“Error Indicator Table” on page 2-2** and take the indicated action. Unplug the machine to clear the error indicator.

If an error indicator appears, go to the error indicator table and take the indicated action for that error.

The printer also logs the last occurring error. If you think it may have an intermittent error, or the error indicator lights have been cleared, you can retrieve the error:

1. Run the **“Test Page” on page 3-8**. The error is the last number to print on line five. Note the number.
2. Run **“Initialize Error Log” on page 3-3** to clear the error (the error may not be the result of a current error).
3. Run the **“Parallel Port Test” on page 3-4**. If no error appears, go to **“Power-On Self Test (POST) Sequence” on page 2-2**.

If your machine does not have an error indicated, go to **“Power-On Self Test (POST) Sequence” on page 2-2**.

## Error Indicator Table

Error Code	Number of Power Light Flashes	Action
Blank	<b>8</b>	Replace the system board.
64/ 65	<b>7</b>	Replace the system board.
81	<b>1</b>	Go to the "Carrier Transport Service Check" on page 2-6.
89	<b>4</b>	Go to the "Carrier Transport Service Check" on page 2-6.
127 and up	<b>10</b>	Replace the system board.

## Power-On Self Test (POST) Sequence

When you turn the printer on it performs a POST. Turn your machine on and check for a correct POST operation by observing the following:

1. The lights come on.
2. The carrier moves.
3. The paper feed gears turn.
4. After 30 seconds the carrier moves over the maintenance station and caps the printhead.
5. All motors stop and the power light stays on.

If your machine completes POST with no errors, go to the "Symptom Tables" on page 2-4, locate the symptom and take the indicated action.

If your machine does not complete POST, locate the symptom in the following table and take the indicated action.

**POST Symptom Table**

<b>Symptom</b>	<b>Action</b>
No Power On light and no motors run	Go to the <b>"Power Service Check"</b> on page 2-12.
Power light, but no busy light	Replace the system board.
Paper feed gears do not turn	Go to the <b>"Paper Feed Service Check"</b> on page 2-9.
Carrier doesn't move	Go to the <b>"Carrier Transport Service Check"</b> on page 2-6.
Carrier slams side frame	Go to the <b>"Carrier Transport Service Check"</b> on page 2-6.

## Symptom Tables

Locate the symptom in the following tables and take the appropriate action.

### Carrier Transport Problems

Symptom	Action
<ul style="list-style-type: none"> <li>• No carrier movement</li> <li>• Slow carrier movement</li> <li>• Carrier stops</li> <li>• Carrier slams side frame</li> </ul>	Go to the <b>“Carrier Transport Service Check”</b> on page 2-6.

### Communications Problems

Symptom	Action
Printer not communicating with host computer.	Go to the <b>“Parallel Port Service Check”</b> on page 2-12.

### Maintenance Station Problems

Symptom	Action
Maintenance station: <ul style="list-style-type: none"> <li>• Fails to cap the printhead</li> <li>• Fails to clean the printhead</li> </ul>	Go to the <b>“Maintenance Station Service Check”</b> on page 2-8.

### Operator Panel

Symptom	Action
Paper Feed and / or Install print cartridge buttons do not operate	Replace the system board.
Busy light does not come on	Replace the system board

**Paper Feed Problems**

Symptom	Action
<ul style="list-style-type: none"> <li>• Fails to pick paper</li> <li>• Picks more than one sheet of paper</li> <li>• Picks paper but fails to feed</li> <li>• Paper jams</li> <li>• Paper fails to exit</li> <li>• Noisy paper feed</li> </ul>	Go to the “Paper Feed Service Check” on page 2-9.
Envelopes fail to feed	Go to the “Envelope Feed Service Check” on page 2-7.
Paper skews	Go to the “Paper Path Service Check” on page 2-11.

**Power Problems**

Symptom	Action
No power in machine, no Power On light, no motors	Go to the “Power Service Check” on page 2-12.

**Print Quality Problems**

Symptom	Action
<ul style="list-style-type: none"> <li>• Voids in characters</li> <li>• Light print</li> <li>• Prints off the page</li> <li>• Fuzzy print</li> <li>• Carrier moves but no print</li> <li>• Printhead dries prematurely</li> <li>• Colors print incorrectly</li> <li>• Vertical alignment off</li> </ul>	Go to the “Print Quality Service Check” on page 2-13.
<ul style="list-style-type: none"> <li>• Ink smearing</li> <li>• Vertical streaks on paper</li> <li>• Print lines crowded</li> </ul>	Go to the “Paper Feed Service Check” on page 2-9.

## Service Checks

### Carrier Transport Service Check

	FRU	Action
1	System Board	<p>Check the motor for binds, or loose motor pulley.</p> <p>Turn the printer off and disconnect CN4 from the system board. Turn the printer on and check for a pulse of (approximately) 10 V dc between CN4-1 and ground and CN4-4 and ground, on the system board, as the machine goes through P-O-S-T. If the voltage is not present, check for motor pins shorted to the motor housing. If you find a pin shorted to the housing, replace the motor. If the failure remains, replace the system board.</p>
2	Carrier Transport Motor	<p>A noisy or chattering motor or a motor that fails to turn can be caused by:</p> <ul style="list-style-type: none"> <li>• An open or short in the motor.</li> <li>• An open or short in the motor driver on the system board.</li> <li>• A bind in the carrier transport mechanism.</li> </ul> <p>With the carrier transport motor cable disconnected from the system board, check for zero to ten (0 - 10) ohms between the following pins on the motor:</p> <p style="text-align: center;">CN4-1 and CN4-2 CN4-3 and CN4-4</p> <p>If the readings are incorrect, replace the motor.</p>
3	Carrier Guide Rod	<p>Clean the carrier rod.</p> <p><b>Note:</b> Do not lubricate the rod or the carrier rod bearing surface.</p>
4	Carrier Transport Belt Idler Pulley Parts Carrier Frame	<p>Check for worn, loose or broken parts. Check for obstructions blocking carrier movement.</p> <p>Carrier to carrier frame engagement should be lubricated with grease P/N 1329301.</p>



	FRU	Action
6	Home Position Sensor	Perform the <b>“EOF and Home Position Sensors Test”</b> on page 3-2, to check the Home Position Sensor. If you cannot enter the test, replace the system board. If the test fails, turn the printer off and disconnect CN5 from the system board. Turn the printer on and check for 5 V dc between CN5-1 and ground, at the system board. If the voltage is present, replace the home position sensor. If the voltage is not present, replace the system board.
7	Maintenance Station	A problem with the maintenance station can cause carrier movement problems at the right margin. Go to the <b>“Maintenance Station Service Check”</b> on page 2-8.

## Envelope Feed Service Check

	FRU	Action
1	Envelope Guide	Be sure the envelope guide has been turned to the envelope load position. Be sure the envelope guide is against the envelopes. Perform the <b>“Paper Feed Service Check”</b> on page 2-9.

## Maintenance Station Service Check

The maintenance station has two functions:

1. Cleans the printhead nozzles during the print operation.
2. Seals the printhead when it is not being used to prevent the nozzles from drying.

	FRU	Action
1	Maintenance Station Assembly	<p>As the carrier moves to the right over the maintenance station, a slot on the bottom of the carrier engages a tab on the sled of the maintenance station causing the cap to rise and seal the printhead. Carrier movement to the left uncaps the printhead. The wiper cleans the printhead nozzles as the carrier leaves the maintenance station. The wiper cleans the printhead only when the carrier is moving to the left. There should be no wiping action of the printhead nozzles when the carrier is moving to the right. After the cleaning operation is complete, a tab on the maintenance station engages a tab on the carrier, causing the wiper to lower.</p> <p>Check the maintenance station for worn or broken parts.</p>
2	Wiper	A worn wiper causes degraded print quality just after a maintenance cleaning. Check for a loose or worn wiper.
3	Cap	A worn cap causes the printhead nozzles to dry and clog. Check for a loose or worn cap.

## Paper Feed Service Check

If your machine does not have paper jam problems, continue with the service check. If your machine does have a paper jam problem, examine it for the following before you begin the service check:

- Check the entire paper path for obstructions.
- Be sure there is not too much paper in the sheet feeder.
- Be sure the correct type of paper is being used.
- Check for static in the paper.

	<b>FRU</b>	<b>Action</b>
1	System Board	Turn the printer off and disconnect CN6 from the system board. Turn the printer on and check for a pulse of 24 V dc between CN6-1 and ground and CN6-2 and ground on the system board, as the machine goes through P-O-S-T. If the voltage is not present, check for motor pins shorted to the motor housing. If you find a shorted pin, replace the motor. If you still have a failure after replacing the motor, replace the system board.

	FRU	Action
2	Paper Feed Motor	<p>A noisy or chattering motor or a motor that fails to turn, can be caused by:</p> <ul style="list-style-type: none"> <li>• An open or short in the motor</li> <li>• An open or short in the motor driver on the system board</li> <li>• A bind in the paper feed mechanism</li> </ul> <p>With the paper feed motor cable disconnected from the system board, check for 60 ohms (<math>\pm 15</math> ohms) between the following pins on the motor:</p> <p>Pin 2 to Pin 5 Pin 2 to Pin 6 130 ohms (<math>\pm 20</math> ohms) between pins 5 and 6.</p> <p>If the readings are incorrect, replace the motor.</p> <p>Although the paper feeds in a forward direction only, the paper feed motor turns in two directions. If the paper feed motor turns in one direction only, replace the system board.</p> <p>Binds in the paper feed motor or gear train can cause intermittent false paper jam errors. Remove the paper feed motor and check the shaft for binds. Also check for loose or worn motor gear.</p>
3	Drive Train Assembly	<p>Check for binds in the gear train and paper feed mechanism by removing the paper feed motor and rotating the large gear by hand. If you notice a bind, replace the drive train assembly. Check the feed clutch inside the large feed gear. Remove the sheet feeder. Turn the clutch gear and check that it rotates freely in one direction and locks when turned in the opposite direction.</p>
4	Auto Sheet Feeder	<p>Check the pick rollers for wear.</p>
5	Mid Frame Asm Access Cover Asm	<p>Check the following for wear:</p> <ul style="list-style-type: none"> <li>• Friction wheels</li> <li>• Exit roller</li> <li>• Star rollers</li> </ul>
6	End-of-Forms Flag and Spring	<p>Check for binds or damage. If binds are found, replace the small feed roll bracket assembly.</p>

	FRU	Action
7	End of Forms Sensor	Check the sensor for dirt. Perform the <b>“EOF and Home Position Sensors Test”</b> on page 3-2, to check the end of forms sensor on the system board. If the test fails, replace the system board.

## Paper Path Service Check

Examine the machine for the following before you begin this service check:

- Check the entire paper path for obstructions.
- Be sure the correct type of paper is being used.
- Be sure the printer is installed on a flat surface.

	FRU	Action
1	Large and Small Feed Rollers	Check for wear and binds.
2	Small Feed Roller Springs	Check for damage.
3	Auto Sheet Feeder	Check the pick rollers for wear.
4	Mid Frame Asm Access Cover Asm	Check the following for wear: <ul style="list-style-type: none"> <li>• Friction wheels</li> <li>• Exit roller</li> <li>• Star rollers</li> </ul>
5	End-of-Forms Flag	Check for binds or damage.

## Parallel Port Service Check

	FRU	Action
1	Parallel Port	Run a test page to be sure the printer can print. Run the "Parallel Port Test" on page 3-4. If the test fails, replace the system board.

## Power Service Check

	FRU	Action
1	Power Supply	<p>Disconnect CN7 from the system board and check the following voltages on the power supply cable:</p> <ul style="list-style-type: none"> <li>• CN7-1 to GND = +5 V dc</li> <li>• CN7-4 to GND = +24 V dc</li> </ul> <p>If you do not have correct voltage, replace the power supply. Be sure to unplug the machine before you reconnect the power supply to the system board.</p>
2	Printhead Cable Carrier Home Sensor Parallel Cable	<p>Turn off the printer. Disconnect one of the printhead cables and turn on the printer. Look for a symptom change. Check the failing part for shorts and replace as necessary.</p> <p>Repeat this procedure for the carrier home sensor and parallel cable.</p>
3	System Board	If the symptom has not changed, replace the system board.

## Print Quality Service Check

	FRU / Function	Action
1	Print Cartridge	Be sure the machine contains a good print cartridge.
2	Color Print Cartridge Cross Contamination	<p>Cross contamination of color inks results in incorrect colors printed, as when green prints for yellow, (when yellow and blue are mixed in the print cartridge). This problem resolves quickly as the print cartridge is used.</p> <p>If cross contamination occurs, check the following:</p> <ul style="list-style-type: none"> <li>• The maintenance station wiper for damage.</li> <li>• The printhead nozzle plate was resealed with tape.</li> </ul>
3	Printhead Carrier Assembly	<p>Reseat the printhead cables in the system board and check the following parts for wear or damage:</p> <ul style="list-style-type: none"> <li>• Print Cartridge Latch</li> <li>• Latch Spring</li> <li>• Carrier</li> </ul>
4	System Board Printhead Cable Rubber Backer	<ul style="list-style-type: none"> <li>• Run the <b>“Test Page” on page 3-8</b>. Look for a break in the diagonal line of the test pattern. A broken line indicates one or more print nozzles are not working. Run the test again to verify the failure. If there are even breaks in the diagonal line similar to the pattern shown below, ensure the printhead cables are connected properly. If the symptom remains, replace the system board.</li> </ul> <div style="text-align: center;">  </div> <p>If there is a single break or random breaks in the diagonal line check the following:</p> <ul style="list-style-type: none"> <li>• Check the gold-plated contacts, on the end of the cable that connect to the carrier, for dirt and wear. Use only a clean dry cloth to clean the contacts. Also check the cable for damage. You may need to remove the cable from the carrier to inspect it.</li> <li>• A worn rubber backer results in poor contact between the printhead cable and the print cartridge. Check the rubber backer for wear.</li> </ul>

	FRU / Function	Action
5	Maintenance Station	Intermittent nozzle failures can be caused by worn parts in the maintenance station. Perform the <b>“Maintenance Station Service Check”</b> on page 2-8, then return to this check.
6	Paper Feed	Ink smudging and smearing can be caused by paper problems or problems in the paper feed area. Check the following: <ul style="list-style-type: none"> <li>• Correct type of paper is being used. Also check the paper for curl or wrinkles.</li> <li>• Feed rollers for wear, dirt, or looseness.</li> <li>• Gears for wear or binds.</li> <li>• Paper path for obstructions.</li> </ul>
7	Carrier Transport	Blurred print and voids can be caused by problems in the carrier transport area. Check the following: <ul style="list-style-type: none"> <li>• Carrier transport belt for wear.</li> <li>• Carrier guide rod for wear or dirt.</li> <li>• Carrier to carrier frame engagement should be lubricated with grease P/N 1329301. Do not lubricate the carrier guide rod.</li> <li>• Idler pulley parts for wear, damage, or looseness.</li> </ul>
8	Alignment	Uneven vertical lines can be adjusted by performing the bidirectional alignment. The user is directed, through the Printer Control program, to perform the bidirectional printing alignment, when replacing a print cartridge.



## Print Quality Notice

Printers are shipped with three different carrier transport motors displaying a label which reads either NMB(NMB), Airpax(APX) or Mitsumi(MZM). The label on the motor should match the motor ID in NVRAM. To verify the motor ID stored in NVRAM, print out a Test Page. The three letter designation will be printed on the service line.

**If the carrier transport motor or the system board must be replaced**, check the label on the carrier transport motor. All FRU motors will be labeled NMB.

After completing repairs to the printer, connect it to a PC and go to `x:\Tools\4078` (where *x* is the letter of your CD-ROM drive) on your latest Service Information and Training CD-ROM and perform one of the following commands to download the file to your printer. Use the file that matches the transport motor label.

- `x:COPY /B NMB.BIN LPT1`
- `x:COPY /B APX.BIN LPT1`
- `x:COPY /B MZM.BIN LPT1`

---

### 3. Diagnostic Aids

Use these diagnostic test procedures to verify a repair. The test procedures are entered by pressing and holding a button, or buttons, as you turn on the printer. To begin the test, hold the buttons until both the operator panel lights come on and then release the buttons after five seconds. Some tests require the End-of-Form Flag to be out of the sensor.

To remove the End-of-Form Flag from the sensor:

1. Open the sheet feeder.
2. Place a sheet of paper in the paper path until the End-of-Form Flag is tripped.



To terminate the test, turn the printer off.

---

## EOF and Home Position Sensors Test

This test allows the servicer to test the function of the End-of-Form and Home Position sensors.

To run the test:

1. With the printer off and the End-of-Form Flag out of the sensor, press and hold the following buttons while turning the printer on:
2. Paper Feed 
3. Install Print Cartridge 

After five seconds, release the buttons to begin the test.

The Busy light goes on and off as the End-of-Form flag is moved into and out of the End-of-Form sensor.

The Power light goes on and off as the Carrier flag is moved into and out of the Home Position sensor.

---

## Initialize Error Log

This test tracks intermittent errors.

Use this procedure to reset the error log to zero. The error log is especially helpful in diagnosing intermittent or difficult problems. The test is complete when power is turned off.

### To run the test:

1. Place a sheet of paper in the sheet feeder far enough to push the End-of-Form flag out of the sensor.
2. With the printer off, hold down the Install Print Cartridge button  while turning the printer on.

---

## Parallel Port Test

This test performs a wrap around test between the printer parallel port and the parallel port test connector.

This test requires a parallel port wrap plug. Install the wrap plug in the parallel port before you start the test. The power on light flashes if the test is successful. If the test is not successful, the power on light remains off.

### To run the test:

1. With a parallel port wrap plug installed and the printer off, press and hold the following button while turning the printer on:
2. Paper Feed 

After five seconds, release the button to begin the test.

The Power On light blinks upon successful completion of the test.

A failing test causes the Power On light to remain off. Turning the power off or unplugging the printer ends the test.

---

## Print NVRAM Contents

This test prints the contents of NVRAM, which can be used for diagnostic purposes.

To run the test:

1. Install a black print cartridge.
2. Place a sheet of paper in the sheet feeder far enough to push the End-of-Form flag out of the sensor.
3. Load paper into the sheet feeder.
4. With the printer off, press and hold the Paper Feed button  and turn the printer on. After five seconds, release the button to begin the test.



---

## Reset NVRAM to EMEA Defaults

This test resets the user defaults area of NVRAM to the EMEA factory defaults. The page count and the error log do not change.

**Note:** Factory defaults are initially set to USA.

To run the test:

1. With the printer off, press and hold the following buttons while turning the printer on:
  - Paper Feed 
  - Install Print Cartridge 
  
2. After five seconds, release the buttons to begin the test.

A sheet of paper will feed and verify the defaults have been set by printing "EMEA".

---

## Reset NVRAM to USA Defaults

This test resets the user defaults area of NVRAM to the USA factory defaults. The page count and the error log do not change.

**Note:** Factory defaults are initially set to USA.

To run the test:

1. With the printer off, press and hold the Install Print Cartridge  button while turning the printer on:
2. After five seconds, release the button to begin the test.

A sheet of paper will feed and verify the defaults have been set by printing “US”.



---

## Test Page

This test prints the test page.

To run a complete test page of black and color patterns, be sure the print cartridge is in good condition. Install a black print cartridge.

### To enter the test:

- Press and hold the Paper Feed  button while turning the printer on. Paper feeds from the sheet feeder and prints the test page. Pages continue to print until you turn off the power or unplug the printer.

The test page prints the following lines.

Line 1 - Code level.

Line 2 - Manufacturer name.

Line 3 - Model name.

Line 4 - US or EMEA defaults.

Line 5 - Page count followed by the last error.

The next line is the black print cartridge nozzle pattern. The next three lines are the purge pattern where all nozzles are printing. This action cleans (purges) the nozzles. Another nozzle test pattern follows.

These test patterns are used to verify all print cartridge nozzles are working. There should be no breaks in the diagonal line. A break in the diagonal line indicates one or more nozzles are not working.

The rest of the page contains the user defaults followed by a printout of the printer resident fonts.

---

## 4. Repair Information

This chapter explains how to make adjustments to the printer and how to remove defective parts.

**Note:** Read the following before handling electronic parts.

---

### Handling ESD-Sensitive Parts

Many electronic products use parts that are known to be sensitive to electrostatic discharge (ESD). To prevent damage to ESD-sensitive parts, follow the instructions below in addition to all the usual precautions, such as turning off power before removing logic boards:

- Keep the ESD-sensitive part in its original shipping container (a special “ESD bag”) until you are ready to install the part into the machine.
- Make the least-possible movements with your body to prevent an increase of static electricity from clothing fibers, carpets, and furniture.
- Put the ESD wrist strap on your wrist. Connect the wrist band to the system ground point. This discharges any static electricity in your body to the machine.
- Hold the ESD-sensitive part by its edge connector shroud (cover); do not touch its pins. If you are removing a pluggable module, use the correct tool.
- Do not place the ESD-sensitive part on the machine cover or on a metal table; if you need to put down the ESD-sensitive part for any reason, first put it into its special bag.
- Machine covers and metal tables are electrical grounds. They increase the risk of damage because they make a discharge path from your body through the ESD-sensitive part. (Large metal objects can be discharge paths without being grounded.)
- Prevent ESD-sensitive parts from being accidentally touched by other personnel. Install machine covers when you are not working on the machine, and do not put unprotected ESD-sensitive parts on a table.
- If possible, keep all ESD-sensitive parts in a grounded metal cabinet (case).
- Be extra careful in working with ESD-sensitive parts when cold weather heating is used because low humidity increases static electricity.

---

## Adjustments

The user is directed, in the Printer Control program, to perform the bidirectional alignment adjustments after replacing a print cartridge.

---

## Removal Procedures

The following procedures are arranged according to the name of the printer part discussed. Unplug the power cord before removing any parts.

### Releasing Plastic Latches

Many of the parts are held in place with plastic latches. The latches break easily; release them carefully. To remove such parts, press the hook end of the latch away from the part to which it is latched.

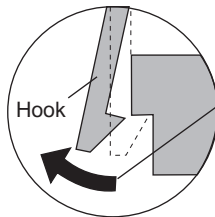

Hook

Never apply excessive force when releasing the hook.

## Access Cover Removal

1. Open the access cover.
2. Push the mounting tabs towards the center of the machine.
3. Remove the access cover.

## Base Assembly Removal

1. Remove the front cover.
2. Remove the rear cover.
3. Remove the sheet feeder.
4. Disconnect the power supply connector at the system board.
5. Remove the two screws that secure the carrier frame to the base assembly.
6. Remove the screw that secures the power supply frame to the carrier frame.
7. Remove the ground strap screw from the system board.
8. Unlatch the carrier frame from the base assembly and lift it off the base.
9. Slide the machine off the base assembly.

## Carrier Belt Removal

1. Remove the front cover.
2. Remove the retainer spring from the left side of the carrier rod.
3. Remove the screw from the right side of the carrier rod.
4. Slide the carrier rod to the left, out of the machine.
5. Remove the carrier belt from the rear of the carrier.
6. Remove the carrier belt from the carrier transport motor pulley.
7. Remove the carrier belt.

## Carrier Frame Assembly Removal

The carrier rail mounted by two screws on the carrier frame is included with the carrier frame (11A5436). The carrier rail, which is not available as a FRU, is mounted in the elongated slots at the factory. During adjustment, the rail is pushed to the rear as far as it will go, before the mounting screws are tightened.

1. Remove the front cover.
2. Remove the rear cover.
3. Remove the sheet feeder.
4. Disconnect the power supply connector at the system board.
5. Remove the two screws that secure the carrier frame to the base assembly.
6. Remove the screw that secures the power supply frame to the carrier frame.
7. Remove the ground strap screw from the system board.
8. Unlatch the carrier frame from the base assembly and lift it off the base.
9. Slide the carrier frame assembly off the base assembly.
10. To replace the carrier frame, remove all associated parts from the old carrier frame and install them on the new carrier frame.

## Carrier Home Sensor Removal

1. Remove the front cover.
2. Remove the rear cover.
3. Disconnect the sensor cable from the system board.
4. Remove the screw that secures the sensor to the carrier frame.
5. Remove the sensor.

## Carrier Transport Motor Removal

1. Remove the front cover.
2. Remove the rear cover.
3. Disconnect the carrier transport motor connector from the system board.
4. Remove the belt from the carrier transport motor pulley.
5. Remove the two screws securing the carrier transport motor to the carrier frame and remove the motor. Note the routing of the motor cable.
6. See **“Print Quality Notice” on page 2-15.**

## Drive Train Assembly Removal

1. Remove the front cover.
2. Remove the rear cover.
3. Remove the sheet feeder.
4. Remove the base assembly.
5. Remove the system board.
6. Remove the printhead carrier assembly.
7. Remove the small feed roll assemblies.
8. Remove the small feed roll bracket assembly.
9. Remove the mid frame assembly.
10. Remove the maintenance station assembly.
11. Remove the large feed roll.
12. Remove the three screws securing the drive train to the carrier frame.
13. Push the drive train to the right and remove it from the carrier frame.

## Front Cover Removal

1. Turn the printer over to expose the base. Remove the two cover mounting screws from the front cover. When reassembling, do not overtighten these screws as they will break. Replacement screws can be found in parts packet 11A5453.
2. Slide the cover upwards and off the machine.

To reassemble:

1. Align the tabs on the front cover over the front edge of the base assembly.
2. Rotate the front cover over the top edge of the rear cover and press in on both sides opposite the cover latches, until they latch.

## Gutter Pad Removal

1. Remove the front cover.
2. Remove the rear cover.
3. Remove the sheet feeder.
4. Remove the base assembly.
5. Remove the gutter pad from the base assembly.

## **Large Feed Roll Removal**

1. Remove the front cover.
2. Remove the rear cover.
3. Remove the sheet feeder.
4. Remove the base assembly.
5. Remove the system board.
6. Remove the printhead carrier assembly.
7. Remove the small feed roll assemblies.
8. Remove the small feed roll bracket assembly.
9. Remove the mid frame assembly.
10. Remove the maintenance station assembly.
11. Turn and remove the retainer at the right end of the large feed roller.
12. Remove the large feed roller from the carrier frame.

## **Maintenance Station Assembly Removal**

1. Remove the front cover.
2. Remove the rear cover.
3. Remove the base assembly.
4. Remove the screw from the rear of the carrier frame that secures the maintenance station assembly and slide the assembly out of the machine.

## **Maintenance Wiper and Cap Removal**

1. Remove the front cover.
2. Push the carrier to the left away from the maintenance station.
3. Gently pull the cap and wiper off their mountings.



## Mid Frame Assembly Removal

1. Remove the front cover.
2. Remove the rear cover.
3. Remove the sheet feeder.
4. Remove the system board.
5. Remove the small feed roll assemblies.
6. Remove the small feed roll bracket assembly.
7. Remove the printhead carrier assembly.
8. Lift up the rear of the mid frame assembly and remove it from the carrier frame.

## Paper Feed Motor Removal

1. Remove the front cover.
2. Remove the rear cover.
3. Disconnect the paper feed motor from the system board.
4. Remove the two screws mounting the paper feed motor to the drive train assembly and remove the motor.

## Power Supply Removal

1. Remove the front cover.
2. Remove the rear cover.
3. Remove the sheet feeder.
4. Disconnect the power supply connector from the system board.
5. Remove the screw that secures the power supply to the carrier frame.
6. Push down on the latch at the left rear of the power supply and slide it off the base.

## Printhead Carrier Assembly Removal

1. Remove the front cover.
2. Remove the rear cover.
3. Remove the sheet feeder.
4. Unlock the two printhead cable connectors and disconnect the printhead cable from the system board.
5. Unlatch the cable retainer from the carrier frame.
6. Remove the retainer spring from the left end of the carrier guide rod.
7. Remove the screw from the right end of the carrier guide rod.
8. Slide the carrier guide rod out the left side of the machine.
9. Remove the belt from the back of the carrier.
10. Lift the carrier out of the machine.

## Rear Cover Removal

1. Remove the front cover.
2. Pry upwards on the two rear cover latches [A].

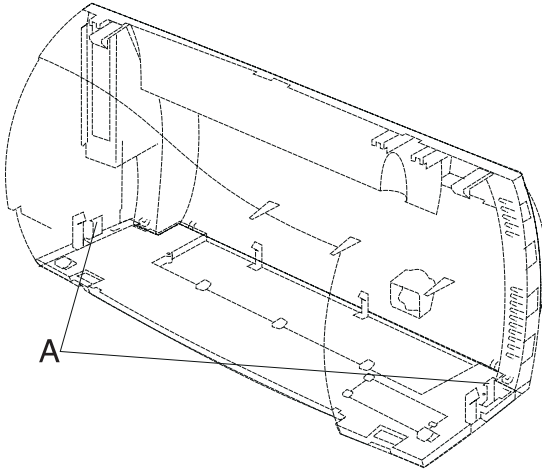

3. Work the tabs of the rear cover free from the base assembly.
4. To reassemble, place the cover over the tabs in the base assembly and press towards the front of the machine until the cover latches. Be sure the parallel connector snaps do not get trapped behind the cover.

## Sheet Feeder Removal

1. Remove the front cover.
2. Remove the rear cover.
3. Remove the two sheet feeder mounting screws from the rear of the carrier frame.
4. Unlatch the right sheet feeder latch from the front of the carrier frame.

**Note:** The cables are routed through tab slots in the sheet feeder. Note this for reassembly.

5. Remove the sheet feeder.

## Small Feed Roll Assembly Removal

1. Remove the front cover.
2. Remove the rear cover.
3. Remove the sheet feeder.
4. Remove the system board.
5. Remove the four small feed roller springs from the carrier frame.
6. Push down on each of the small feed roll assemblies to remove them from the small feed roll bracket.

## Small Feed Roll Bracket Assembly Removal

1. Remove the front cover.
2. Remove the rear cover.
3. Remove the sheet feeder.
4. Remove the system board.
5. Remove the four small feed roller springs from the carrier frame.
6. Push down on each of the small feed roll assemblies to remove them from the small feed roll bracket.
7. Push the two locking tabs [A] to the rear to release the small feed roll assembly from the carrier frame.

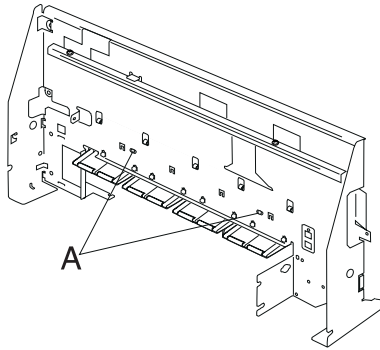

## System Board Removal

1. Remove the front cover.
2. Remove the rear cover.
3. Remove the sheet feeder.
4. Unlock the two printhead cable connectors and disconnect the printhead cables from the system board.
5. Disconnect the other cables from the system board.
6. Remove the three screws securing the system board to the carrier frame and remove the system board. Note the routing of all the cables.
7. Remove the system board being careful not to damage the End-of-Form flag.
8. Set NVRAM to the country default on the replacement system board; see Chapter 3.
9. See **“Print Quality Notice” on page 2-15.**

## 5. Connector Locations

### System Board Connectors

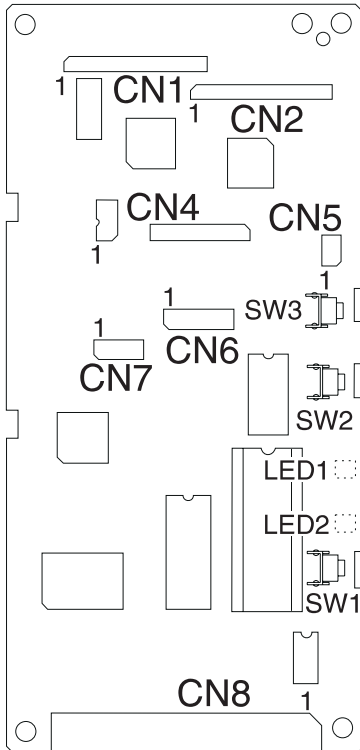

<b>Connector</b>	<b>Connector Names</b>
CN1	Printhead Cable 1
CN2	Printhead Cable 2
CN4	Carrier Transport Motor
CN5	Home Position Sensor
CN6	Paper Feed Motor
CN7	Power Supply
CN8	Parallel Port
SW1	Power Switch
SW2	Paper Feed Switch
SW3	Install Print Cartridge Switch
LED1	Busy Light
LED2	Power on Light



---

## 6. Preventive Maintenance

This chapter contains the lubrication specifications. Follow these recommendations to prevent problems and maintain optimum performance.

---

### Lubrication Specifications

Lubricate only when parts are replaced or as needed, not on a scheduled basis. Use grease P/N 1329301 to lubricate the following:

- All gear mounting studs.
- The left and right ends of the large feed roller at the side frames.
- The carrier to carrier frame engagement.

Do not lubricate the carrier guide rod, or carrier guide rod bearings.

---

## 7. Parts Catalog

---

### How To Use This Parts Catalog

---

- **SIMILAR ASSEMBLIES:** If two assemblies contain a majority of identical parts, they are broken down on the same list. Common parts are shown by one index number. Parts peculiar to one or the other of the assemblies are listed separately and identified by description.
- **NS:** (Not Shown) in the Asm-Index column indicates that the part is procurable but is not pictured in the illustration.
- **PP:** in the parts descriptions column indicates the part is available in the listed parts packet.

4078-00X

Assembly 1: Covers

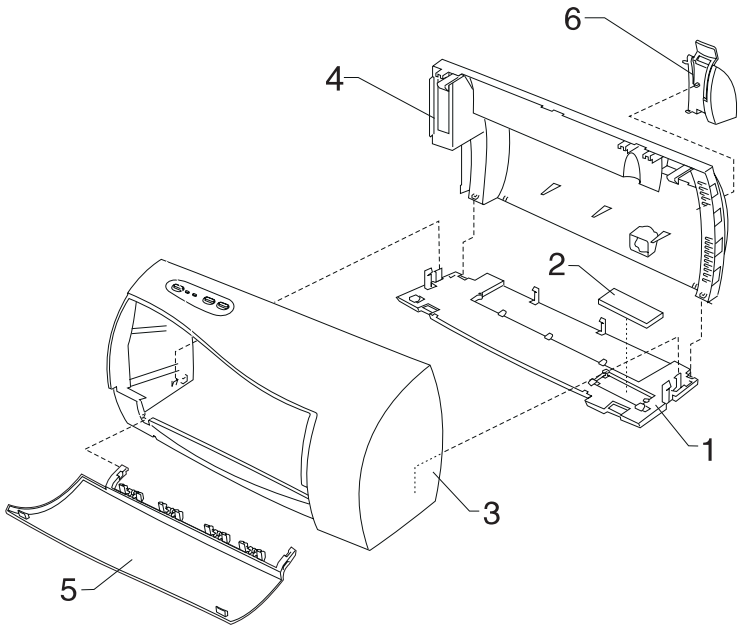

**4078-00X**

<b>Asm-Index</b>	<b>Part Number</b>	<b>Units</b>	<b>Description</b>
1 -1	11A5430	1	Base Asm
-2	11A5431	1	Felt Pad, Ink Absorption
-3	11A5432	1	Cover, Front Asm
-4	11A5433	1	Cover, Rear Asm
-5	11A5434	1	Cover, Access Asm
-6	11A5435	1	Garage Asm

NS	11A5453	2	Front Cover Mounting Screws (PP)
N/S	11A5454	1	Replaceable Package B/M - Includes: (Carton, Cushion Set, Sealing Tape)

4078-00X

## Assembly 2: Paper Feed / Carrier Transport / Maintenance

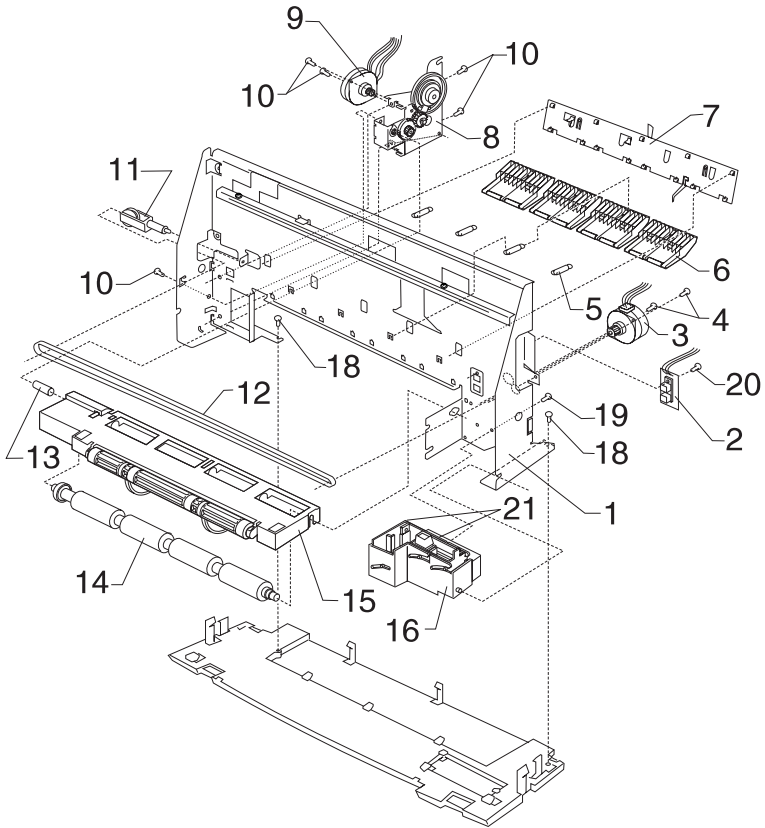

**4078-00X**

<b>Asm-Index</b>	<b>Part Number</b>	<b>Units</b>	<b>Description</b>
2 -1	11A5436	1	Frame, Carrier
-2	11A5438	1	Sensor, Carrier Home
-3	11A5450	1	Motor, Carrier Transport Asm See "Print Quality Notice" on page 2-15.
-4	11A5453	1	Screw, (PP)
-5	11A5453	1	Spring, Small Feed Roll Asm, (PP)
-6	11A5441	1	Feed Roll Assembly, Small
-7	11A5442	1	Mounting Bracket, Small Feed Roll Assembly
-8	11A5443	1	Drive Train Assembly
-9	11A5444	1	Motor, Paper Feed Assembly
-10	11A5453	5	Screws, Drive Train & Paper Feed Motor Mounting (PP)
-11	11A5453	1	Arm, Tensioner (PP)
-12	11A5449	1	Belt, Carrier
-13	11A5453	1	Spring, Large Feed Roll Dampening (PP)
-14	11A5440	1	Feed Roll Assembly, Large
-15	11A5439	1	Frame, Mid Assembly
-16	11A5452	1	Maintenance Assembly
-18	11A5453	2	Screw, (PP)
-19	11A5453	1	Screw, (PP)
-20	11A5453	1	Screw, (PP)
-21	1367389	1	Cap and Wiper B/M

4078-00X

### Assembly 3: Electronics

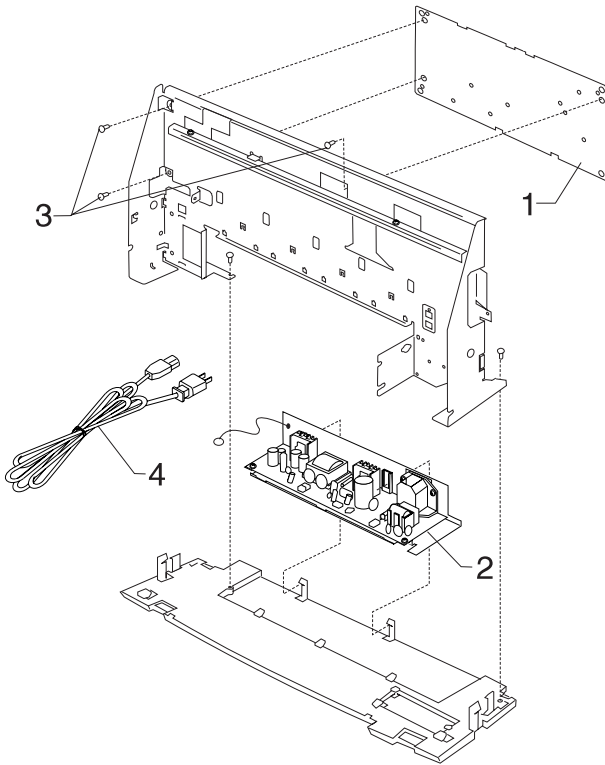

**4078-00X**

<b>Asm-Index</b>	<b>Part Number</b>	<b>Units</b>	<b>Description</b>
3 -1	11A5455	1	System Board with ROM See "Print Quality Notice" on page 2-15.
-2	11A5447	1	Power Supply: 110V
-2	11A5446	1	Power Supply: 220V
-3	11A5453	1	Screws, System Board (PP)



4078-00X

### Assembly 3: Electronics (Continued)

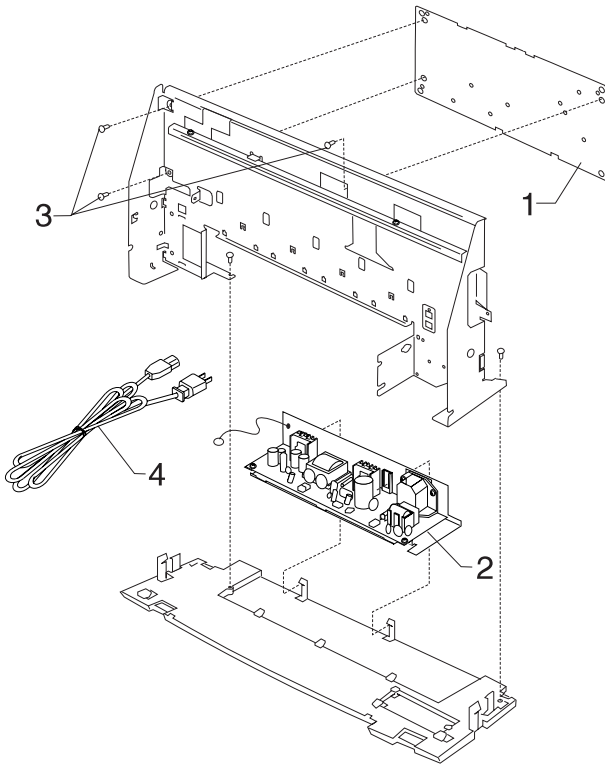

Asm-Index	Part Number	Units	Description
3 -4	1339526 1342536 1339520 1339520 1342514 1342526 1342536 1339526 1342534 1342514 1342514 1339525 1342514 1339519 1342514 1339520 1339520 1339520 1342514 1342514 1339521 1339524 70G0496 1342514 1339520 1342514 1339520 1342514 1342536 1342514 1339520 1339517 1339523 1339520 1339520 1339522 1339519 1342536 1342514	1	Power Cord, U.S. Power Cord, Argentina Power Cord, Austria Power Cord, Belgium Power Cord, Bolivia Power Cord, Brazil (LV) Power Cord, Brazil (HV) Power Cord, Canada Power Cord, Chile Power Cord, Columbia Power Cord, Costa Rica Power Cord, Denmark Power Cord, Ecuador Power Cord, Egypt Power Cord, El Salvador Power Cord, Finland Power Cord, France Power Cord, Germany Power Cord, Guatemala Power Cord, Honduras Power Cord, Israel Power Cord, Italy Power Cord, Japan Power Cord, Mexico Power Cord, Netherlands Power Cord, Nicaragua Power Cord, Norway Power Cord, Panama Power Cord, Paraguay Power Cord, Peru Power Cord, Portugal Power Cord, Saudi Arabia Power Cord, South Africa Power Cord, Spain Power Cord, Sweden Power Cord, Switzerland Power Cord, United Kingdom Power Cord, Uruguay Power Cord, Venezuela

4078-00X

## Assembly 4: Carrier

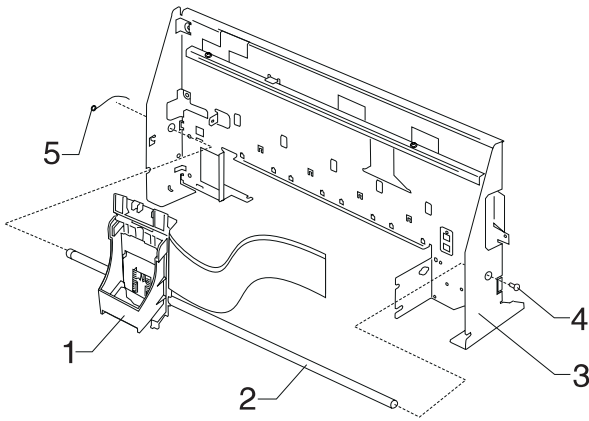

**4078-00X**

<b>Asm-Index</b>	<b>Part Number</b>	<b>Units</b>	<b>Description</b>
4 -1	11A5448	1	Carrier Assembly
-2	11A5437	1	Rod, Carrier Guide
-3	11A5436	1	Frame, Carrier
-4	11A5453	1	Screw, Carrier Guide Rod (PP)
-5	11A5453	1	Spring, Carrier Guide Rod (PP)

4078-00X

## Assembly 5: Sheet Feeder

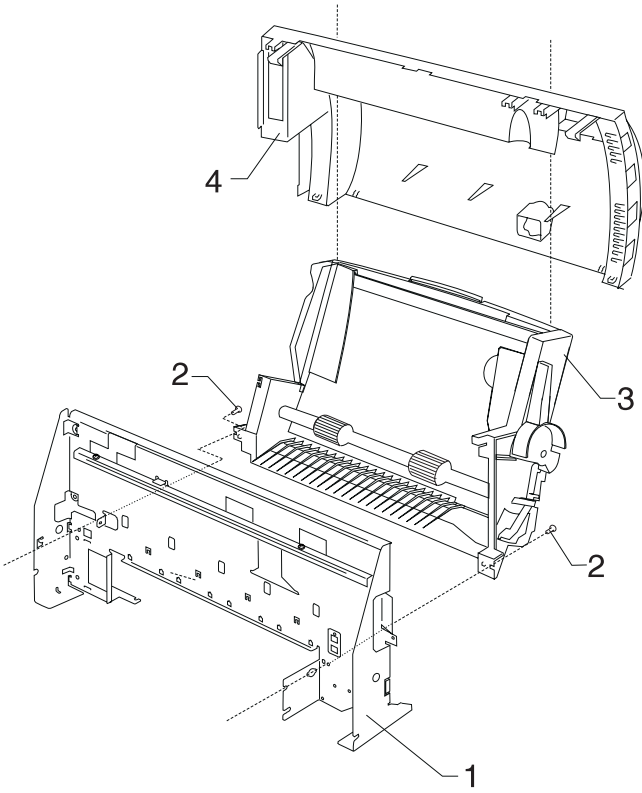

**4078-00X**

<b>Asm-Index</b>	<b>Part Number</b>	<b>Units</b>	<b>Description</b>
5 -1	11A5436	1	Frame, Carrier
-2	11A5453	2	Screws, Sheet Feeder Mounting (PP)
-3	11A5451	1	Sheet Feeder Asm
-4	11A5433	1	Cover, Rear Asm
NS	70G2759	1	Card Feeder Kit, Japan Hagaki

# Index

## A

- Abbreviations 1-2
- Adjustments 4-2
- Assemblies
  - 1 Covers 7-2
  - 2 Carrier Transport 7-4
  - 2 Maintenance Station 7-4
  - 2 Paper Feed 7-4
  - 3 Electronics 7-6
  - 4 Carrier 7-10
  - 5 Sheet Feeder 7-12

## C

- Connector Locations 5-1
- Connectors
  - System Board 5-1

## D

- Diagnostic Aids 3-1
- Diagnostic Information 2-1

## E

- Error Indicator Table 2-2
- ESD-Sensitive Parts 4-1

## G

- General Information 1-1

## L

- Lubrication Specifications 6-1

## M

- Maintenance Approach 1-1

## P

- Parts Catalog 7-1
- Plastic Latches 4-2
- POST
  - Sequence 2-2
  - Symptom Table 2-3
- Power Consumption 1-1
- Preventive Maintenance 6-1
- Problems
  - Carrier Transport 2-4
  - Communications 2-4

- Maintenance Station 2-4
- Paper Feed 2-5
- Power 2-5
- Print Quality 2-5

## R

### Removals

- Access Cover 4-3
- Base Assembly 4-3
- Carrier Belt 4-3
- Carrier Frame 4-4
- Carrier Transport Motor 4-5
- Drive Train Assembly 4-5
- Front Cover 4-6
- Gutter Pad 4-6
- Large Feed Roll 4-7
- Maintenance Station 4-7
- Mid Frame Assembly 4-8
- Paper Feed Motor 4-8
- Power Supply 4-8
- Printhead Carrier 4-9
- Rear Cover 4-10
- Sheet Feeder 4-11
- Small Feed Roll Assembly 4-11
- Small Feed Roll Bracket 4-12
- System Board 4-13
- Wiper & Cap 4-7

### Repair Information 4-1

## S

- Safety Information v
- Service Checks

- Envelope Feed 2-7
- First Print Line 2-8
- Maintenance Station 2-8
- Paper Feed 2-9
- Paper Path 2-11
- Parallel Port 2-12
- Power 2-12
- Print Quality 2-13
- Transport 2-6

### Start 2-1

### Symptom Table (POST) 2-3

### Symptom Tables 2-4

## T

### Tests

- EOF (End-of-Form) 3-2
- Home Position 3-2
- Initialize Error Log 3-3

## 4078-00X

Parallel Port	3-4
Print NVRAM Contents	3-5
Reset NVRAM Defaults	
EMEA	3-6
USA	3-7
Test Page	3-8
Tools	1-2