

ProLiant ML110 Generation 4 Server

Maintenance and Service Guide



Legal notices

© Copyright 2007 Hewlett-Packard Development Company, L.P.

The information contained herein is subject to change without notice. The only warranties for HP products and services are set forth in the express warranty statements accompanying such products and services. Nothing herein should be construed as constituting an additional warranty. HP shall not be liable for technical or editorial errors or omissions contained herein.

Intel Pentium, Xeon and Celeron are trademarks or registered trademarks of Intel Corporation or its subsidiaries in the United States and other countries.

Part number: 419971-002

Second edition: September 2007

Contents

1	Customer self repair	
	Parts only warranty service	5
2	Illustrated parts catalog	
	Mechanical Components	14
	System components	17
	HP contact information	19
	Before you contact HP	20
3	Removal and replacement procedures	
	Hardware configuration tools	21
	Hardware configuration information	21
	Non-hot-plug device	21
	Electrostatic discharge information	21
	Symbols on equipment	21
	Pre-installation instructions	22
	Post-installation instructions	22
	Powering down the server	23
	System covers	23
	Access panel	23
	Front bezel	24
	Drives	25
	Cable management	25
	Cable connections	26
	Drive bay configuration	26
	Releasing drives	27
	Optical drive	27
	Optional media device	28
	Hard drives	29
	Drive latch	31
	System board components	32
	Processor	32
	Memory	35
	Expansion cards	36
	System battery	41
	Power supply unit (PSU)	42
	System fan	43
	Install IPMI Card	45
4	Diagnostic tools and Setup Utilities	
	BIOS Software	46
	BIOS Setup Utility	46
	Accessing the BIOS Setup Utility	46
	Navigating through the Setup Utility	46
	Setup Utility Menu Bar	48
	BIOS Update	53
	Clear CMOS	53
	Power-On Self-Test (POST)	54
	POST Error Indicators	54
	Recoverable POST Errors	54
	POST Related Troubleshooting	55
5	Connectors, switches and LEDs	
	Connectors and components	56
	Front panel components	56

Rear panel components	56
System board components.....	57
Jumpers – Password and Boot Block	58
Clear CMOS button	58
Status LED indicators	58
Front panel LED indicators.....	58
Rear panel LED indicators	60
System board LED indicators	60
6 Physical and operating specifications	
System unit.....	62
Memory.....	64
Processor	64
IDE CD-ROM drive	65
SAS hard drive	66
SATA hard drive	66
SAS storage controller	67
Index	

1 Customer self repair

HP products are designed with many Customer Self Repair (CSR) parts to minimize repair time and allow for greater flexibility in performing defective parts replacement. If during the diagnosis period HP (or HP service providers or service partners) identifies that the repair can be accomplished by the use of a CSR part, HP will ship that part directly to you for replacement. There are two categories of CSR parts:

- **Mandatory** – Parts for which customer self repair is mandatory. If you request HP to replace these parts, you will be charged for the travel and labor costs of this service.
- **Optional** – Parts for which customer self repair is optional. These parts are also designed for customer self repair. If, however, you require that HP replace them for you, there may or may not be additional charges, depending on the type of warranty service designated for your product.

NOTE: Some HP parts are not designed for customer self repair. In order to satisfy the customer warranty, HP requires that an authorized service provider replace the part. These parts are identified as "No" in the Illustrated Parts Catalog.

Based on availability and where geography permits, CSR parts will be shipped for next business day delivery. Same day or four-hour delivery may be offered at an additional charge where geography permits. If assistance is required, you can call the HP Technical Support Center and a technician will help you over the telephone. HP specifies in the materials shipped with a replacement CSR part whether a defective part must be returned to HP. In cases where it is required to return the defective part to HP, you must ship the defective part back to HP within a defined period of time, normally five (5) business days. The defective part must be returned with the associated documentation in the provided shipping material. Failure to return the defective part may result in HP billing you for the replacement. With a customer self repair, HP will pay all shipping and part return costs and determine the courier/carrier to be used.

For more information about HP's Customer Self Repair program, contact your local service provider. For the North American program, refer to the HP website (<http://www.hp.com/go/selfrepair>).

Parts only warranty service

Your HP Limited Warranty may include a parts only warranty service. Under the terms of parts only warranty service, HP will provide replacement parts free of charge.

For parts only warranty service, CSR part replacement is mandatory. If you request HP to replace these parts, you will be charged for the travel and labor costs of this service.

Réparation par le client (CSR)

Les produits HP comportent de nombreuses pièces CSR (Customer Self Repair = réparation par le client) afin de minimiser les délais de réparation et faciliter le remplacement des pièces défectueuses. Si pendant la période de diagnostic, HP (ou ses partenaires ou mainteneurs agréés) détermine que la réparation peut être effectuée à l'aide d'une pièce CSR, HP vous l'envoie directement. Il existe deux catégories de pièces CSR:

- **Obligatoire** – Pièces pour lesquelles la réparation par le client est obligatoire. Si vous demandez à HP de remplacer ces pièces, les coûts de déplacement et main d'œuvre du service vous seront facturés.
- **Facultatif** – Pièces pour lesquelles la réparation par le client est facultative. Ces pièces sont également conçues pour permettre au client d'effectuer lui-même la réparation. Toutefois, si vous demandez à HP de remplacer ces pièces, l'intervention peut ou non vous être facturée, selon le type de garantie applicable à votre produit.

REMARQUE: Certaines pièces HP ne sont pas conçues pour permettre au client d'effectuer lui-même la réparation. Pour que la garantie puisse s'appliquer, HP exige que le remplacement de la pièce soit effectué par un Mainteneur Agréé. Ces pièces sont identifiées par la mention "Non" dans le Catalogue illustré.

Les pièces CSR sont livrées le jour ouvré suivant, dans la limite des stocks disponibles et selon votre situation géographique. Si votre situation géographique le permet et que vous demandez une livraison le jour même ou dans les 4 heures, celle-ci vous sera facturée. Pour bénéficier d'une assistance téléphonique, appelez le Centre d'assistance technique HP. Dans les documents envoyés avec la pièce de rechange CSR, HP précise s'il est nécessaire de lui retourner la pièce défectueuse. Si c'est le cas, vous devez le faire dans le délai indiqué, généralement cinq (5) jours ouvrés. La pièce et sa documentation doivent être retournées dans l'emballage fourni. Si vous ne retournez pas la pièce défectueuse, HP se réserve le droit de vous facturer les coûts de remplacement. Dans le cas d'une pièce CSR, HP supporte l'ensemble des frais d'expédition et de retour, et détermine la société de courses ou le transporteur à utiliser.

Pour plus d'informations sur le programme CSR de HP, contactez votre Mainteneur Agrée local. Pour plus d'informations sur ce programme en Amérique du Nord, consultez le site Web HP (<http://www.hp.com/go/selfrepair>).

Service de garantie "pièces seules"

Votre garantie limitée HP peut inclure un service de garantie "pièces seules". Dans ce cas, les pièces de rechange fournies par HP ne sont pas facturées.

Dans le cadre de ce service, la réparation des pièces CSR par le client est obligatoire. Si vous demandez à HP de remplacer ces pièces, les coûts de déplacement et main d'œuvre du service vous seront facturés.

Riparazione da parte del cliente

Per abbreviare i tempi di riparazione e garantire una maggiore flessibilità nella sostituzione di parti difettose, i prodotti HP sono realizzati con numerosi componenti che possono essere riparati direttamente dal cliente (CSR, Customer Self Repair). Se in fase di diagnostica HP (o un centro di servizi o di assistenza HP) identifica il guasto come riparabile mediante un ricambio CSR, HP lo spedisce direttamente al cliente per la sostituzione. Vi sono due categorie di parti CSR:

- **Obbligatorie** – Parti che devono essere necessariamente riparate dal cliente. Se il cliente ne affida la riparazione ad HP, deve sostenere le spese di spedizione e di manodopera per il servizio.
- **Opzionali** – Parti la cui riparazione da parte del cliente è facoltativa. Si tratta comunque di componenti progettati per questo scopo. Se tuttavia il cliente ne richiede la sostituzione ad HP, potrebbe dover sostenere spese aggiuntive a seconda del tipo di garanzia previsto per il prodotto.

NOTA: alcuni componenti HP non sono progettati per la riparazione da parte del cliente. Per rispettare la garanzia, HP richiede che queste parti siano sostituite da un centro di assistenza autorizzato. Tali parti sono identificate da un "No" nel Catalogo illustrato dei componenti.

In base alla disponibilità e alla località geografica, le parti CSR vengono spedite con consegna entro il giorno lavorativo seguente. La consegna nel giorno stesso o entro quattro ore è offerta con un supplemento di costo solo in alcune zone. In caso di necessità si può richiedere l'assistenza telefonica di un addetto del centro di supporto tecnico HP. Nel materiale fornito con una parte di ricambio CSR, HP specifica se il cliente deve restituire dei componenti. Qualora sia richiesta la resa ad HP del componente difettoso, lo si deve spedire ad HP entro un determinato periodo di tempo, generalmente cinque (5) giorni lavorativi. Il componente difettoso deve essere restituito con la documentazione associata nell'imballo di spedizione fornito. La mancata restituzione del componente può comportare la fatturazione del ricambio da parte di HP. Nel caso di riparazione da parte del cliente, HP sostiene tutte le spese di spedizione e resa e sceglie il corriere/vettore da utilizzare.

Per ulteriori informazioni sul programma CSR di HP contattare il centro di assistenza di zona. Per il programma in Nord America fare riferimento al sito Web HP (<http://www.hp.com/go/selfrepair>).

Servizio di garanzia per i soli componenti

La garanzia limitata HP può includere un servizio di garanzia per i soli componenti. Nei termini di garanzia del servizio per i soli componenti, HP fornirà gratuitamente le parti di ricambio.

Per il servizio di garanzia per i soli componenti è obbligatoria la formula CSR che prevede la riparazione da parte del cliente. Se il cliente invece richiede la sostituzione ad HP, dovrà sostenere le spese di spedizione e di manodopera per il servizio.

Customer Self Repair

HP Produkte enthalten viele CSR-Teile (Customer Self Repair), um Reparaturzeiten zu minimieren und höhere Flexibilität beim Austausch defekter Bauteile zu ermöglichen. Wenn HP (oder ein HP Servicepartner) bei der Diagnose feststellt, dass das Produkt mithilfe eines CSR-Teils repariert werden kann, sendet Ihnen HP dieses Bauteil zum Austausch direkt zu. CSR-Teile werden in zwei Kategorien unterteilt:

- **Zwingend** – Teile, für die das Customer Self Repair-Verfahren zwingend vorgegeben ist. Wenn Sie den Austausch dieser Teile von HP vornehmen lassen, werden Ihnen die Anfahrt- und Arbeitskosten für diesen Service berechnet.
- **Optional** – Teile, für die das Customer Self Repair-Verfahren optional ist. Diese Teile sind auch für Customer Self Repair ausgelegt. Wenn Sie jedoch den Austausch dieser Teile von HP vornehmen lassen möchten, können bei diesem Service je nach den für Ihr Produkt vorgesehenen Garantiebedingungen zusätzliche Kosten anfallen.

HINWEIS: Einige Teile sind nicht für Customer Self Repair ausgelegt. Um den Garantieanspruch des Kunden zu erfüllen, muss das Teil von einem HP Servicepartner ersetzt werden. Im illustrierten Teilekatalog sind diese Teile mit „No“ bzw. „Nein“ gekennzeichnet.

CSR-Teile werden abhängig von der Verfügbarkeit und vom Lieferziel am folgenden Geschäftstag geliefert. Für bestimmte Standorte ist eine Lieferung am selben Tag oder innerhalb von vier Stunden gegen einen Aufpreis verfügbar. Wenn Sie Hilfe benötigen, können Sie das HP technische Support Center anrufen und sich von einem Mitarbeiter per Telefon helfen lassen. Den Materialien, die mit einem CSR-Ersatzteil geliefert werden, können Sie entnehmen, ob das defekte Teil an HP zurückgeschickt werden muss. Wenn es erforderlich ist, das defekte Teil an HP zurückzuschicken, müssen Sie dies innerhalb eines vorgegebenen Zeitraums tun, in der Regel innerhalb von fünf (5) Geschäftstagen. Das defekte Teil muss mit der zugehörigen Dokumentation in der Verpackung zurückgeschickt werden, die im Lieferumfang enthalten ist. Wenn Sie das defekte Teil nicht zurückschicken, kann HP Ihnen das Ersatzteil in Rechnung stellen. Im Falle von Customer Self Repair kommt HP für alle Kosten für die Lieferung und Rücksendung auf und bestimmt den Kurier-/Frachtdienst.

Weitere Informationen über das HP Customer Self Repair Programm erhalten Sie von Ihrem Servicepartner vor Ort. Informationen über das CSR-Programm in Nordamerika finden Sie auf der HP Website unter (<http://www.hp.com/go/selfrepair>).

Parts-only Warranty Service (Garantieservice ausschließlich für Teile)

Ihre HP Garantie umfasst möglicherweise einen Parts-only Warranty Service (Garantieservice ausschließlich für Teile). Gemäß den Bestimmungen des Parts-only Warranty Service stellt HP Ersatzteile kostenlos zur Verfügung.

Für den Parts-only Warranty Service ist das CSR-Verfahren zwingend vorgegeben. Wenn Sie den Austausch dieser Teile von HP vornehmen lassen, werden Ihnen die Anfahrt- und Arbeitskosten für diesen Service berechnet.

Reparaciones del propio cliente

Los productos de HP incluyen muchos componentes que el propio usuario puede reemplazar (*Customer Self Repair*, CSR) para minimizar el tiempo de reparación y ofrecer una mayor flexibilidad a la hora de realizar sustituciones de componentes defectuosos. Si, durante la fase de diagnóstico, HP (o los proveedores o socios de servicio de HP) identifica que una reparación puede llevarse a cabo mediante el uso de un componente CSR, HP le enviará dicho componente directamente para que realice su sustitución. Los componentes CSR se clasifican en dos categorías:

- **Obligatorio** – componentes para los que la reparación por parte del usuario es obligatoria. Si solicita a HP que realice la sustitución de estos componentes, tendrá que hacerse cargo de los gastos de desplazamiento y de mano de obra de dicho servicio.
- **Opcional** – componentes para los que la reparación por parte del usuario es opcional. Estos componentes también están diseñados para que puedan ser reparados por el usuario. Sin embargo, si precisa que HP realice su sustitución, puede o no conllevar costes adicionales, dependiendo del tipo de servicio de garantía correspondiente al producto.

NOTA: Algunos componentes no están diseñados para que puedan ser reparados por el usuario. Para que el usuario haga valer su garantía, HP pone como condición que un proveedor de servicios autorizado realice la sustitución de estos componentes. Dichos componentes se identifican con la palabra "No" en el catálogo ilustrado de componentes.

Según la disponibilidad y la situación geográfica, los componentes CSR se enviarán para que lleguen a su destino al siguiente día laborable. Si la situación geográfica lo permite, se puede solicitar la entrega en el mismo día o en cuatro horas con un coste adicional. Si precisa asistencia técnica, puede llamar al Centro de asistencia técnica de HP y recibirá ayuda telefónica por parte de un técnico. Con el envío de materiales para la sustitución de componentes CSR, HP especificará si los componentes defectuosos deberán devolverse a HP. En aquellos casos en los que sea necesario devolver algún componente a HP, deberá hacerlo en el periodo de tiempo especificado, normalmente cinco días laborables. Los componentes defectuosos deberán devolverse con toda la documentación relacionada y con el embalaje de envío. Si no enviara el componente defectuoso requerido, HP podrá cobrarle por el de sustitución. En el caso de todas sustituciones que lleve a cabo el cliente, HP se hará cargo de todos los gastos de envío y devolución de componentes y escogerá la empresa de transporte que se utilice para dicho servicio.

Para obtener más información acerca del programa de Reparaciones del propio cliente de HP, póngase en contacto con su proveedor de servicios local. Si está interesado en el programa para Norteamérica, visite la página web de HP siguiente (<http://www.hp.com/go/selfrepair>).

Servicio de garantía exclusivo de componentes

La garantía limitada de HP puede que incluya un servicio de garantía exclusivo de componentes. Según las condiciones de este servicio exclusivo de componentes, HP le facilitará los componentes de repuesto sin cargo adicional alguno.

Para este servicio de garantía exclusivo de componentes, es obligatoria la sustitución de componentes por parte del usuario (CSR). Si solicita a HP que realice la sustitución de estos componentes, tendrá que hacerse cargo de los gastos de desplazamiento y de mano de obra de dicho servicio.

Customer Self Repair

Veel onderdelen in HP producten zijn door de klant zelf te repareren, waardoor de reparatieduur tot een minimum beperkt kan blijven en de flexibiliteit in het vervangen van defecte onderdelen groter is. Deze onderdelen worden CSR-onderdelen (Customer Self Repair) genoemd. Als HP (of een HP Service Partner) bij de diagnose vaststelt dat de reparatie kan worden uitgevoerd met een CSR-

onderdeel, verzendt HP dat onderdeel rechtstreeks naar u, zodat u het defecte onderdeel daarmee kunt vervangen. Er zijn twee categorieën CSR-onderdelen:

- **Verplicht** – Onderdelen waarvoor reparatie door de klant verplicht is. Als u HP verzoekt deze onderdelen voor u te vervangen, worden u voor deze service reiskosten en arbeidsloon in rekening gebracht.
- **Optioneel** – Onderdelen waarvoor reparatie door de klant optioneel is. Ook deze onderdelen zijn ontworpen voor reparatie door de klant. Als u echter HP verzoekt deze onderdelen voor u te vervangen, kunnen daarvoor extra kosten in rekening worden gebracht, afhankelijk van het type garantieservice voor het product.

OPMERKING: Sommige HP onderdelen zijn niet ontwikkeld voor reparatie door de klant. In verband met de garantievoorzwaarden moet het onderdeel door een geautoriseerde Service Partner worden vervangen. Deze onderdelen worden in de geïllustreerde onderdelencatalogus aangemerkt met "Nee".

Afhankelijk van de leverbaarheid en de locatie worden CSR-onderdelen verzonden voor levering op de eerstvolgende werkdag. Levering op dezelfde dag of binnen vier uur kan tegen meerkosten worden aangeboden, indien dit mogelijk is gezien de locatie. Indien assistentie gewenst is, belt u een HP Service Partner om via de telefoon technische ondersteuning te ontvangen. HP vermeldt in de documentatie bij het vervangende CSR-onderdeel of het defecte onderdeel aan HP moet worden geretourneerd. Als het defecte onderdeel aan HP moet worden teruggezonden, moet u het defecte onderdeel binnen een bepaalde periode, gewoonlijk vijf (5) werkdagen, retourneren aan HP. Het defecte onderdeel moet met de bijbehorende documentatie worden geretourneerd in het meegeleverde verpakkingsmateriaal. Als u het defecte onderdeel niet terugzendt, kan HP u voor het vervangende onderdeel kosten in rekening brengen. Bij reparatie door de klant betaalt HP alle verzendkosten voor het vervangende en geretourneerde onderdeel en kiest HP zelf welke koerier/transportonderneming hiervoor wordt gebruikt.

Neem contact op met een Service Partner voor meer informatie over het Customer Self Repair programma van HP. Informatie over Service Partners vindt u op de HP website (<http://www.hp.nl/services/servicepartners>).

Garantieservice "Parts Only"

Het is mogelijk dat de HP garantie alleen de garantieservice "Parts Only" omvat. Volgens de bepalingen van de Parts Only garantieservice zal HP kosteloos vervangende onderdelen ter beschikking stellen.

Voor de Parts Only garantieservice is vervanging door CSR-onderdelen verplicht. Als u HP verzoekt deze onderdelen voor u te vervangen, worden u voor deze service reiskosten en arbeidsloon in rekening gebracht.

Reparo feito pelo cliente

Os produtos da HP são projetados com muitas peças para reparo feito pelo cliente (CSR) de modo a minimizar o tempo de reparo e permitir maior flexibilidade na substituição de peças com defeito. Se, durante o período de diagnóstico, a HP (ou fornecedores/parceiros de serviço da HP) concluir que o reparo pode ser efetuado pelo uso de uma peça CSR, a peça de reposição será enviada diretamente ao cliente. Existem duas categorias de peças CSR:

- **Obrigatória** – Peças cujo reparo feito pelo cliente é obrigatório. Se desejar que a HP substitua essas peças, serão cobradas as despesas de transporte e mão-de-obra do serviço.
- **Opcional** – Peças cujo reparo feito pelo cliente é opcional. Essas peças também são projetadas para o reparo feito pelo cliente. No entanto, se desejar que a HP as substitua, pode haver ou não a cobrança de taxa adicional, dependendo do tipo de serviço de garantia destinado ao produto.

OBSERVAÇÃO: Algumas peças da HP não são projetadas para o reparo feito pelo cliente. A fim de cumprir a garantia do cliente, a HP exige que um técnico autorizado substitua a peça. Essas peças estão identificadas com a marca "No" (Não), no catálogo de peças ilustrado.

Conforme a disponibilidade e o local geográfico, as peças CSR serão enviadas no primeiro dia útil após o pedido. Onde as condições geográficas permitirem, a entrega no mesmo dia ou em quatro horas pode ser feita mediante uma taxa adicional. Se precisar de auxílio, entre em contato com o Centro de suporte técnico da HP para que um técnico o ajude por telefone. A HP especifica nos materiais fornecidos com a peça CSR de reposição se a peça com defeito deve ser devolvida à HP. Nos casos em que isso for necessário, é preciso enviar a peça com defeito à HP dentro do período determinado, normalmente cinco (5) dias úteis. A peça com defeito deve ser enviada com a documentação correspondente no material de transporte fornecido. Caso não o faça, a HP poderá cobrar a reposição. Para as peças de reparo feito pelo cliente, a HP paga todas as despesas de transporte e de devolução da peça e determina a transportadora/serviço postal a ser utilizado.

Para obter mais informações sobre o programa de reparo feito pelo cliente da HP, entre em contato com o fornecedor de serviços local. Para o programa norte-americano, visite o site da HP (<http://www.hp.com/go/selfrepair>).

Serviço de garantia apenas para peças

A garantia limitada da HP pode incluir um serviço de garantia apenas para peças. Segundo os termos do serviço de garantia apenas para peças, a HP fornece as peças de reposição sem cobrar nenhuma taxa.

No caso desse serviço, a substituição de peças CSR é obrigatória. Se desejar que a HP substitua essas peças, serão cobradas as despesas de transporte e mão-de-obra do serviço.

顧客自己修理保証サービス

修理時間を短縮し、故障部品の交換における高い柔軟性を確保するために、HP製品には多数の顧客自己修理 (CSR) 部品があります。診断の際に、CSR部品を使用すれば修理ができるとHP (HPまたはHP正規保守代理店) が判断した場合、HPはその部品を直接、お客様に発送し、お客様に交換していただきます。CSR部品には以下の2通りがあります。

- 必須-顧客自己修理が必須の部品。当該部品について、もしもお客様がHPに交換作業を依頼される場合には、その修理サービスに関する交通費および人件費がお客様に請求されます。
- 任意-顧客自己修理が任意である部品。この部品も顧客自己修理用です。当該部品について、もしもお客様がHPに交換作業を依頼される場合には、お買い上げの製品に適用される保証サービス内容の範囲内においては、別途費用を負担していただくことなく保証サービスを受けることができます。

注： HP製品の一部の部品は、顧客自己修理用ではありません。製品の保証を継続するためには、HPまたはHP正規保守代理店による交換作業が必須となります。部品カタログには、当該部品が顧客自己修理除外品である旨が記載されています。

部品供給が可能な場合、地域によっては、CSR部品を翌営業日に届くように発送します。また、地域によっては、追加費用を負担いただくことにより同日または4時間以内に届くように発送することも可能な場合があります。サポートが必要なときは、HPの修理受付窓口にご連絡いただければ、技術者が電話でアドバイスします。交換用のCSR部品または同梱物には、故障部品をHPに返送する必要があるかどうかが表示されています。故障部品をHPに返送する必要がある場合は、指定期限内（通常は5営業日以内）に故障部品をHPに返送してください。故障部品を返送する場合は、届いた時の梱包箱に関連書類とともに入れてください。故障部品を返送しない場合、HPから部品費用が請求されます。顧客自己修理の際には、HPは送料および部品返送費を全額負担し、使用する宅配便会社や運送会社を指定します。

部品のみ保証サービス

HP保証サービスには、部品のみ保証サービスが適用される場合があります。このサービスでは、交換部品は無償で提供されます。

部品のみ保証サービスにおいては、CSR部品をお客様により交換作業していただくことが必須となります。当該部品について、もしもお客様がHPに交換作業を依頼される場合には、その修理サービスに関する交通費および人件費はお客様の負担となります。

客户自行维修

HP 产品提供许多客户自行维修 (CSR) 部件，以尽可能缩短维修时间和在更换缺陷部件方面提供更大的灵活性。如果在诊断期间 HP（或 HP 服务提供商或服务合作伙伴）确定可以通过使用 CSR 部件完成维修，HP 将直接把该部件发送给您进行更换。有两类 CSR 部件：

- **强制性的** — 要求客户必须自行维修的部件。如果您请求 HP 更换这些部件，则必须为该服务支付差旅费和人工费用。
- **可选的** — 客户可以选择是否自行维修的部件。这些部件也是为客户自行维修设计的。不过，如果您要求 HP 为您更换这些部件，则根据为您的产品指定的保修服务类型，HP 可能收取或不再收取任何附加费用。

注：某些 HP 部件的设计并未考虑客户自行维修。为了满足客户保修的需要，HP 要求授权服务提供商更换相关部件。这些部件在部件图解目录中标记为“否”。

CSR 部件将在下一个工作日发运（取决于备货情况和允许的地理范围）。在允许的地理范围内，可在当天或四小时内发运，但要收取额外费用。如果需要帮助，您可以致电 HP 技术支持中心，将会有技术人员通过电话为您提供帮助。HP 会在随更换的 CSR 部件发运的材料中指明是否必须将有缺陷的部件返还给 HP。如果要求您将有缺陷的部件返还给 HP，那么您必须在规定期限内（通常是五 (5) 个工作日）将缺陷部件发给 HP。有缺陷的部件必须随所提供的发运材料中的相关文件一起返还。如果未能送还有缺陷的部件，HP 可能会要求您支付更换费用。客户自行维修时，HP 将承担所有相关运输和部件返回费用，并指定快递员/承运商。

有关 HP 客户自行维修计划的详细信息，请与您当地的服务提供商联系。有关北美地区的计划，请访问 HP 网站 (<http://www.hp.com/go/selfrepair>)。

仅部件保修服务

您的 HP 有限保修服务可能涉及仅部件保修服务。根据仅部件保修服务条款的规定，HP 将免费提供更换的部件。

仅部件保修服务要求进行 CSR 部件更换。如果您请求 HP 更换这些部件，则必须为该服务支付差旅费和人工费用。

客戶自行維修

HP 產品設計了許多「客戶自行維修」(CSR) 的零件以減少維修時間，並且使得更換瑕疵零件時能有更大的彈性。如果在診斷期間 HP (或 HP 服務供應商或維修夥伴) 辨認出此項維修工作可以藉由使用 CSR 零件來完成，則 HP 將直接寄送該零件給您作更換。CSR 零件分為兩種類別：

- **強制的** — 客戶自行維修所使用的零件是強制性的。如果您要求 HP 更換這些零件，HP 將會向您收取此服務所需的外出費用與勞動成本。
- **選購的** — 客戶自行維修所使用的零件是選購的。這些零件也設計用於客戶自行維修之用。不過，如果您要求 HP 為您更換，則可能需要也可能不需要負擔額外的費用，端視針對此產品指定的保固服務類型而定。

備註：某些 HP 零件沒有消費者可自行維修的設計。為符合客戶保固，HP 需要授權的服務供應商更換零件。這些零件在圖示的零件目錄中，被標示為「否」。

基於材料取得及環境允許的情況下，CSR 零件將於下一個工作日以快遞寄送。在環境的允許下當天或四小時內送達，則可能需要額外的費用。若您需要協助，可致電「HP 技術支援中心」，會有一位技術人員透過電話來協助您。不論損壞的零件是否必須退回，HP 皆會在與 CSR 替換零件一起運送的材料中註明。若要將損壞的零件退回 HP，您必須在指定的一段時間內（通常為五 (5) 個工作天），將損壞的零件寄回 HP。損壞的零件必須與寄送資料中隨附的相關技術文件一併退還。如果無法退還損壞的零件，HP 可能要向您收取替換費用。針對客戶自行維修情形，HP 將負責所有運費及零件退還費用並指定使用何家快遞/貨運公司。

如需 HP 的「客戶自行維修」方案詳細資訊，請連絡您當地的服務供應商。至於北美方案，請參閱 HP 網站 (<http://www.hp.com/go/selfrepair>)。

僅限零件的保固服務

您的「HP 有限保固」可能包含僅限零件的保固服務。在僅限零件的保固服務情況下，HP 將免費提供替換零件。

針對僅限零件的保固服務，CSR 零件替換是強制性的。如果您要求 HP 更換這些零件，HP 將會向您收取此服務所需的外出費用與勞動成本。

고객 셀프 수리

HP 제품은 수리 시간을 최소화하고 결함이 있는 부품 교체 시 더욱 융통성을 발휘할 수 있도록 하기 위해 고객 셀프 수리(CSR) 부품을 다량 사용하여 설계되었습니다. 진단 기간 동안 HP(또는 HP 서비스 공급업체 또는 서비스 협력업체)에서 CSR 부품을 사용하여 수리가 가능하다고 판단되면 HP는 해당 부품을 바로 사용자에게 보내어 사용자가 교체할 수 있도록 합니다. CSR 부품에는 두 가지 종류가 있습니다.

- **고객 셀프 수리가 의무 사항인 필수 부품.** 사용자가 HP에 이 부품의 교체를 요청할 경우 이 서비스에 대한 출장비 및 작업비가 청구됩니다.
- **고객 셀프 수리가 선택 사항인 부품.** 이 부품들도 고객 셀프 수리가 가능하도록 설계되었습니다. 하지만 사용자가 HP에 이 부품의 교체를 요청할 경우 사용자가 구입한 제품에 해당하는 보증 서비스 유형에 따라 추가 비용 없이 교체가 가능할 수 있습니다.

참고: 일부 HP 부품은 고객 셀프 수리가 불가능하도록 설계되었습니다. HP는 만족스러운 고객 보증을 위해 공인 서비스 제공업체를 통해 부품을 교체하도록 하고 있습니다. 이러한 부품들은 Illustrated Parts Catalog에 "No"라고 표시되어 있습니다.

CSR 부품은 재고 상태와 지리적 조건이 허용하는 경우 다음 영업일 납품이 가능하도록 배송이 이루어집니다. 지리적 조건이 허용하는 경우 추가 비용이 청구되는 조건으로 당일 또는 4시간 배송이 가능할 수도 있습니다. 도움이 필요하시면 HP 기술 지원 센터로 전화하십시오. 전문 기술자가 전화로 도움을 줄 것입니다. HP는 결함이 발생한 부품을 HP로 반환해야 하는지 여부를 CSR 교체 부품과 함께 배송된 자료에 지정합니다. 결함이 발생한 부품을 HP로 반환해야 하는 경우에는 지정된 기간 내(통상 영업일 기준 5일)에 HP로 반환해야 합니다. 이 때 결함이 발생한 부품은 제공된 포장 재료에 넣어 관련 설명서와 함께 반환해야 합니다. 결함이 발생한 부품을 반환하지 않는 경우 HP가 교체 부품에 대해 비용을 청구할 수 있습니다. 고객 셀프 수리의 경우, HP는 모든 운송 및 부품 반환 비용을 부담하며 이용할 운송업체 및 택배 서비스를 결정합니다.

HP 고객 셀프 수리 프로그램에 대한 자세한 내용은 가까운 서비스 제공업체에 문의하십시오. 북미 지역의 프로그램에 대해서는 HP 웹 사이트(<http://www.hp.com/go/selfrepair>)를 참조하십시오.

부품 제공 보증 서비스

HP 제한 보증에는 부품 제공 보증 서비스가 포함될 수 있습니다. 이러한 경우 HP는 부품 제공 보증 서비스의 조건에 따라 교체 부품만을 무료로 제공합니다.

부품 제공 보증 서비스 제공 시 CSR 부품 교체는 의무 사항입니다. 사용자가 HP에 이 부품의 교체를 요청할 경우 이 서비스에 대한 출장비 및 작업비가 청구됩니다.

2 Illustrated parts catalog

This chapter provides the illustrated parts breakdown and spare parts lists for the HP ProLiant ML110 Generation 4 server. Information for contacting HP is also provided.

Mechanical Components

Figure 2-1 Mechanical Components

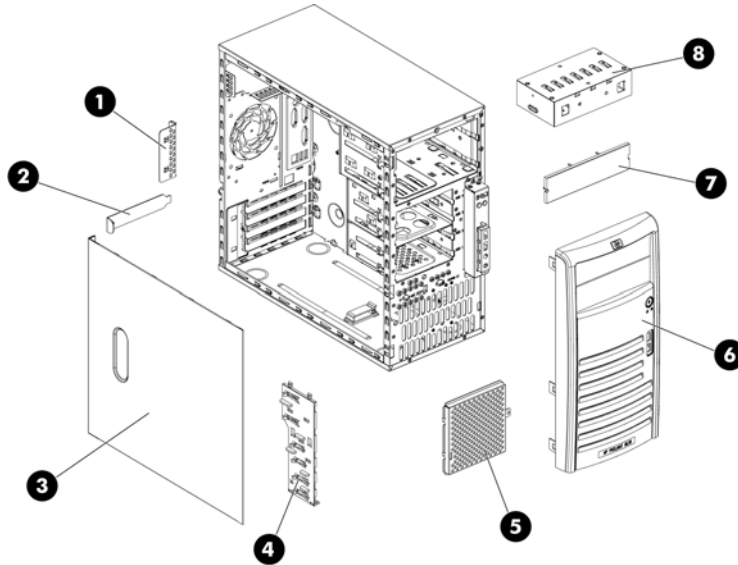

Table 2-1 Mechanical spare parts list

Item	Description	Assembly number	Spare part number	Customer self repair
1	Expansion slot cover lock	397084-001	433557-001	Mandatory ¹
2	IPMI card bracket dummy	434032-001	433557-001	Mandatory ¹
3	Access panel	437973-001	440223-001	Mandatory ¹
4	Drive release latch	434031-001	433557-001	Mandatory ¹
5	Hard drive EMI shield	430277-001	430412-001	Mandatory ¹
6	Front bezel	391980-001	392174-001	Mandatory ¹
7	Blank bezel	166775-004	335937-001 335937-005	Mandatory ¹
8	Drive shield	395019-001	395625-001	Mandatory ¹
9	Misc Plastics/Hardware Kit*, including: <ul style="list-style-type: none"> Screw, 6-32x.187, TF, HI/TP w/serr Screw, M3, TT, HI/TP, S151PX5mm Feet Thumbscrew, 6-32X.25,Cbn 	192308-003 247348-001 166939-007 124702-004	397119-001	Mandatory ¹

*Not shown

¹Mandatory—Parts for which customer self repair is mandatory. If you request HP to replace these parts, you will be charged for the travel and labor costs of this service.

²Optional—Parts for which customer self repair is optional. These parts are also designed for customer self repair. If, however, you require that HP replace them for you, there may or may not be additional charges, depending on the type of warranty service designated for your product.

³No—Some HP parts are not designed for customer self repair. In order to satisfy the customer warranty, HP requires that an authorized service provider replace the part. These parts are identified as "No" in the Illustrated Parts Catalog.

¹Mandatory: Obligatoire—Pièces pour lesquelles la réparation par le client est obligatoire. Si vous demandez à HP de remplacer ces pièces, les coûts de déplacement et main d'œuvre du service vous seront facturés.

²Optional: Facultatif—Pièces pour lesquelles la réparation par le client est facultative. Ces pièces sont également conçues pour permettre au client d'effectuer lui-même la réparation. Toutefois, si vous demandez à HP de remplacer ces pièces, l'intervention peut ou non vous être facturée, selon le type de garantie applicable à votre produit.

³No: Non—Certaines pièces HP ne sont pas conçues pour permettre au client d'effectuer lui-même la réparation. Pour que la garantie puisse s'appliquer, HP exige que le remplacement de la pièce soit effectué par un Mainteneur Agréé. Ces pièces sont identifiées par la mention "Non" dans le Catalogue illustré.

¹Mandatory: Obbligatorie—Parti che devono essere necessariamente riparate dal cliente. Se il cliente ne affida la riparazione ad HP, deve sostenere le spese di spedizione e di manodopera per il servizio.

²Optional: Opzionali—Parti la cui riparazione da parte del cliente è facoltativa. Si tratta comunque di componenti progettati per questo scopo. Se tuttavia il cliente ne richiede la sostituzione ad HP, potrebbe dover sostenere spese addizionali a seconda del tipo di garanzia previsto per il prodotto.

³No: Non CSR—Alcuni componenti HP non sono progettati per la riparazione da parte del cliente. Per rispettare la garanzia, HP richiede che queste parti siano sostituite da un centro di assistenza autorizzato. Tali parti sono identificate da un "No" nel Catalogo illustrato dei componenti.

¹Mandatory: Zwingend—Teile, die im Rahmen des Customer Self Repair Programms ersetzt werden müssen. Wenn Sie diese Teile von HP ersetzen lassen, werden Ihnen die Versand- und Arbeitskosten für diesen Service berechnet.

²Optional: Optional—Teile, für die das Customer Self Repair-Verfahren optional ist. Diese Teile sind auch für Customer Self Repair ausgelegt. Wenn Sie jedoch den Austausch dieser Teile von HP vornehmen lassen möchten, können bei diesem Service je nach den für Ihr Produkt vorgesehenen Garantiebedingungen zusätzliche Kosten anfallen.

³No: Kein—Einige Teile sind nicht für Customer Self Repair ausgelegt. Um den Garantieanspruch des Kunden zu erfüllen, muss das Teil von einem HP Servicepartner ersetzt werden. Im illustrierten Teilekatalog sind diese Teile mit „No“ bzw. „Nein“ gekennzeichnet.

¹Mandatory: Obligatorio—componentes para los que la reparación por parte del usuario es obligatoria. Si solicita a HP que realice la sustitución de estos componentes, tendrá que hacerse cargo de los gastos de desplazamiento y de mano de obra de dicho servicio.

²Optional: Opcional— componentes para los que la reparación por parte del usuario es opcional. Estos componentes también están diseñados para que puedan ser reparados por el usuario. Sin embargo, si precisa que HP realice su sustitución, puede o no conllevar costes adicionales, dependiendo del tipo de servicio de garantía correspondiente al producto.

³No: No—Algunos componentes no están diseñados para que puedan ser reparados por el usuario. Para que el usuario haga valer su garantía, HP pone como condición que un proveedor de servicios autorizado realice la sustitución de estos componentes. Dichos componentes se identifican con la palabra "No" en el catálogo ilustrado de componentes.

¹Mandatory: Verplicht—Onderdelen waarvoor Customer Self Repair verplicht is. Als u HP verzoekt deze onderdelen te vervangen, komen de reiskosten en het arbeidsloon voor uw rekening.

²Optional: Optioneel—Onderdelen waarvoor reparatie door de klant optioneel is. Ook deze onderdelen zijn ontworpen voor reparatie door de klant. Als u echter HP verzoekt deze onderdelen voor u te vervangen, kunnen daarvoor extra kosten in rekening worden gebracht, afhankelijk van het type garanteservice voor het product.

³No: Nee—Sommige HP onderdelen zijn niet ontwikkeld voor reparatie door de klant. In verband met de garantievoorwaarden moet het onderdeel door een geautoriseerde Service Partner worden vervangen. Deze onderdelen worden in de geïllustreerde onderdelencatalogus aangemerkt met "Nee".

¹Mandatory: Obrigatória—Peças cujo reparo feito pelo cliente é obrigatório. Se desejar que a HP substitua essas peças, serão cobradas as despesas de transporte e mão-de-obra do serviço.

²Optional: Opcional—Peças cujo reparo feito pelo cliente é opcional. Essas peças também são projetadas para o reparo feito pelo cliente. No entanto, se desejar que a HP as substitua, pode haver ou não a cobrança de taxa adicional, dependendo do tipo de serviço de garantia destinado ao produto.

³No: Nenhuma—Algumas peças da HP não são projetadas para o reparo feito pelo cliente. A fim de cumprir a garantia do cliente, a HP exige que um técnico autorizado substitua a peça. Essas peças estão identificadas com a marca “No” (Não), no catálogo de peças ilustrado.

¹Mandatory: 必須 - 顧客自己修理が必須の部品。当該部品について、もしもお客様がHPに交換作業を依頼される場合には、その修理サービスに関する交通費および人件費がお客様に請求されます。

²Optional: 任意 - 顧客自己修理が任意である部品。この部品も顧客自己修理用です。当該部品について、もしもお客様がHPに交換作業を依頼される場合には、お買い上げの製品に適用される保証サービス内容の範囲内においては、費用を負担していただくことなく保証サービスを受けることができます。

³No: 除外 - HP製品の一部の部品は、顧客自己修理用ではありません。製品の保証を継続するためには、HPまたはHP正規保守代理店による交換作業が必須となります。部品カタログには、当該部品が顧客自己修理除外品である旨が記載されています。

¹Mandatory: 强制性的 — 要求客户必须自行维修的部件。如果您请求 HP 更换这些部件，则必须为该服务支付差旅费和人工费用。

²Optional: 可选的 — 客户可以选择是否自行维修的部件。这些部件也是为客户自行维修设计的。不过，如果您要求 HP 为您更换这些部件，则根据您的产品指定的保修服务类型，HP 可能收取或不再收取任何附加费用。

³No: 否 — 某些 HP 部件的设计并未考虑客户自行维修。为了满足客户保修的需要，HP 要求授权服务提供商更换相关部件。这些部件在部件图解目录中标记为“否”。

¹Mandatory: 強制的 — 客戶自行維修所使用的零件是強制的。如果您要求 HP 更換這些零件，HP 將會向您收取此服務所需的外出費用與勞動成本。

²Optional: 選購的 — 客戶自行維修所使用的零件是選購的。這些零件也設計用於客戶自行維修之用。不過，如果您要求 HP 為您更換，則可能需要也可能不需要負擔額外的費用，端視針對此產品指定的保固服務類型而定。

³No: 否 — 某些 HP 零件沒有消費者可自行維修的設計。為符合客戶保固，HP 需要授權的服務供應商更換零件。這些零件在圖示的零件目錄中，被標示為「否」。

¹ Mandatory: 필수 — 고객 셀프 수리가 의무 사항인 필수 부품. 사용자가 HP에 이 부품의 교체를 요청할 경우 이 서비스에 대한 출장비 및 작업비가 청구됩니다.

² Optional: 옵션 — 고객 셀프 수리가 선택 사항인 부품. 이 부품들도 고객 셀프 수리가 가능하도록 설계되었습니다. 하지만 사용자가 HP에 이 부품의 교체를 요청할 경우 사용자가 구입한 제품에 해당하는 보증 서비스 유형에 따라 추가 비용 없이 교체가 가능할 수 있습니다.

³ No: No — 고객 셀프 수리가 불가능하도록 설계된 HP 부품. 이 부품들은 고객 셀프 수리가 불가능하도록 설계되었습니다. HP는 고객 보증을 만족시키기 위해 공인 서비스 제공업체를 통해 부품을 교체하도록 하고 있습니다.

System components

Figure 2-2 System components

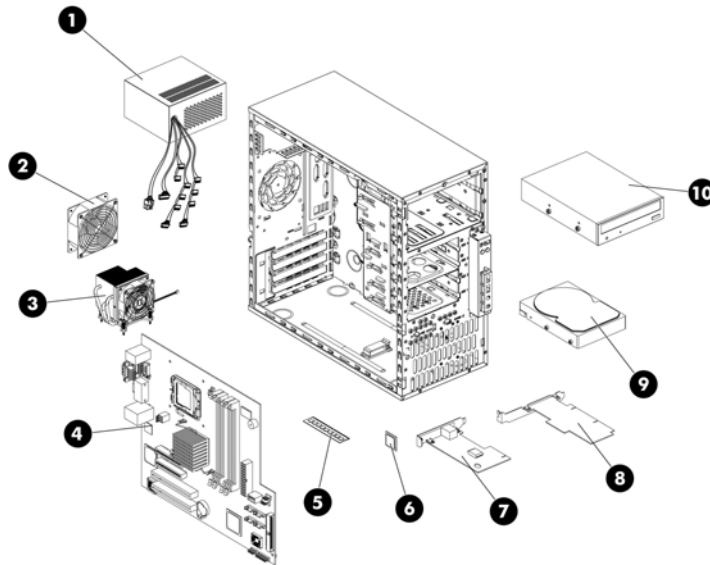

Table 2-2 System components spare parts list

Item	Description	Assembly number	Spare part number	Customer self repair
1	370-W power supply unit with cable assembly	416121-001	419029-001	Mandatory ¹
2	System fan	391976-001	392172-001	Mandatory ¹
3	Processor cooler assembly	418441-001	433549-001	Optional ²
4	System board	416120-001	419028-001	Optional ²
5	Memory module (PC2-5300 unbuffered ECC DDR II DIMM)			
	a) 512 MB	417440-051 (ALL) 417440-251 (BRZL)	433555-001	Mandatory ¹
	b) 1 GB	417439-051	432930-001	Mandatory ¹
	c) 2 GB	417438-061	433935-001	Mandatory ¹
6	Processors (include alcohol pad and thermal grease)			
	a) Intel® Xeon® 1.86GHZ/1066MHZ FSB with 2M L2 Cache	434381-001	436522-001	Optional ²
	b) Intel® Pentium® -D 915 2.8GHZ/800M FSB with 4M Cache	403277-101	436174-001	Optional ²
	c) Intel® Celeron® -D 3.2GHZ/533MHZ FSB with 512K Cache	408802-201	418779-001	Optional ²
7	IPMI Card (HP Lights-Out 100c Remote Management Card)	418278-001	433556-001	Mandatory ¹
8	SAS card	435234-001	435709-001	Mandatory ¹
9	SAS/SATA hard drive			
	a) SATA hard drive	397377-002	399967-001	Mandatory ¹
	b) SAS hard drive	375874-011	389343-001	Mandatory ¹
	Mass storage devices			
10	48X CD-ROM drive	266072-004	413383-001	Mandatory ¹
	Misc parts			
11	CD-ROM drive cable assembly, ATA100 *	430278-001	430413-001	Mandatory ¹
12	SAS hard drive cable *	430762-001	433550-001	Mandatory ¹

Table 2-2 System components spare parts list

Item	Description	Assembly number	Spare part number	Customer self repair
13	SATA hard drive cable *	430274-001	430542-001	Mandatory ¹
14	USB/Power LED cable*	437907-001	440225-001	Mandatory ¹

*Not shown

¹Mandatory—Parts for which customer self repair is mandatory. If you request HP to replace these parts, you will be charged for the travel and labor costs of this service.

²Optional—Parts for which customer self repair is optional. These parts are also designed for customer self repair. If, however, you require that HP replace them for you, there may or may not be additional charges, depending on the type of warranty service designated for your product.

³No—Some HP parts are not designed for customer self repair. In order to satisfy the customer warranty, HP requires that an authorized service provider replace the part. These parts are identified as "No" in the Illustrated Parts Catalog.

¹Mandatory: Obligatoire—Pièces pour lesquelles la réparation par le client est obligatoire. Si vous demandez à HP de remplacer ces pièces, les coûts de déplacement et main d'œuvre du service vous seront facturés.

²Optional: Facultatif—Pièces pour lesquelles la réparation par le client est facultative. Ces pièces sont également conçues pour permettre au client d'effectuer lui-même la réparation. Toutefois, si vous demandez à HP de remplacer ces pièces, l'intervention peut ou non vous être facturée, selon le type de garantie applicable à votre produit.

³No: Non—Certains pièces HP ne sont pas conçues pour permettre au client d'effectuer lui-même la réparation. Pour que la garantie puisse s'appliquer, HP exige que le remplacement de la pièce soit effectué par un Mainteneur Agréé. Ces pièces sont identifiées par la mention "Non" dans le Catalogue illustré.

¹Mandatory: Obbligatorie—Parti che devono essere necessariamente riparate dal cliente. Se il cliente ne affida la riparazione ad HP, deve sostenere le spese di spedizione e di manodopera per il servizio.

²Optional: Opzionali—Parti la cui riparazione da parte del cliente è facoltativa. Si tratta comunque di componenti progettati per questo scopo. Se tuttavia il cliente ne richiede la sostituzione ad HP, potrebbe dover sostenere spese addizionali a seconda del tipo di garanzia previsto per il prodotto.

³No: Non CSR—Alcuni componenti HP non sono progettati per la riparazione da parte del cliente. Per rispettare la garanzia, HP richiede che queste parti siano sostituite da un centro di assistenza autorizzato. Tali parti sono identificate da un "No" nel Catalogo illustrato dei componenti.

¹Mandatory: Zwingend—Teile, die im Rahmen des Customer Self Repair Programms ersetzt werden müssen. Wenn Sie diese Teile von HP ersetzen lassen, werden Ihnen die Versand- und Arbeitskosten für diesen Service berechnet.

²Optional: Optional—Teile, für die das Customer Self Repair-Verfahren optional ist. Diese Teile sind auch für Customer Self Repair ausgelegt. Wenn Sie jedoch den Austausch dieser Teile von HP vornehmen lassen möchten, können bei diesem Service je nach den für Ihr Produkt vorgesehenen Garantiebedingungen zusätzliche Kosten anfallen.

³No: Kein—Einige Teile sind nicht für Customer Self Repair ausgelegt. Um den Garantieanspruch des Kunden zu erfüllen, muss das Teil von einem HP Servicepartner ersetzt werden. Im illustrierten Teilekatalog sind diese Teile mit „No“ bzw. „Nein“ gekennzeichnet.

¹Mandatory: Obligatorio—componentes para los que la reparación por parte del usuario es obligatoria. Si solicita a HP que realice la sustitución de estos componentes, tendrá que hacerse cargo de los gastos de desplazamiento y de mano de obra de dicho servicio.

²Optional: Opcional— componentes para los que la reparación por parte del usuario es opcional. Estos componentes también están diseñados para que puedan ser reparados por el usuario. Sin embargo, si precisa que HP realice su sustitución, puede o no conllevar costes adicionales, dependiendo del tipo de servicio de garantía correspondiente al producto.

³No: No—Algunos componentes no están diseñados para que puedan ser reparados por el usuario. Para que el usuario haga valer su garantía, HP pone como condición que un proveedor de servicios autorizado realice la sustitución de estos componentes. Dichos componentes se identifican con la palabra "No" en el catálogo ilustrado de componentes.

¹Mandatory: Verplicht—Onderdelen waarvoor Customer Self Repair verplicht is. Als u HP verzoekt deze onderdelen te vervangen, komen de reiskosten en het arbeidsloon voor uw rekening.

²Optional: Optioneel—Onderdelen waarvoor reparatie door de klant optioneel is. Ook deze onderdelen zijn ontworpen voor reparatie door de klant. Als u echter HP verzoekt deze onderdelen voor u te vervangen, kunnen daarvoor extra kosten in rekening worden gebracht, afhankelijk van het type garantieservice voor het product.

³No: Nee—Sommige HP onderdelen zijn niet ontwikkeld voor reparatie door de klant. In verband met de garantiev voorwaarden moet het onderdeel door een geautoriseerde Service Partner worden vervangen. Deze onderdelen worden in de geïllustreerde onderdelencatalogus aangemerkt met "Nee".

¹Mandatory: Obrigatória—Peças cujo reparo feito pelo cliente é obrigatório. Se desejar que a HP substitua essas peças, serão cobradas as despesas de transporte e mão-de-obra do serviço.

²Optional: Opcional—Peças cujo reparo feito pelo cliente é opcional. Essas peças também são projetadas para o reparo feito pelo cliente. No entanto, se desejar que a HP as substitua, pode haver ou não a cobrança de taxa adicional, dependendo do tipo de serviço de garantia destinado ao produto.

³No: Nenhuma—Algumas peças da HP não são projetadas para o reparo feito pelo cliente. A fim de cumprir a garantia do cliente, a HP exige que um técnico autorizado substitua a peça. Essas peças estão identificadas com a marca "No" (Não), no catálogo de peças ilustrado.

¹Mandatory: 必須 - 顧客自己修理が必須の部品。当該部品について、もしもお客様がHPに交換作業を依頼される場合には、その修理サービスに関する交通費および人件費がお客様に請求されます。

²Optional: 任意 - 顧客自己修理が任意である部品。この部品も顧客自己修理用です。当該部品について、もしもお客様がHPに交換作業を依頼される場合には、お買い上げの製品に適用される保証サービス内容の範囲内においては、費用を負担していただくことなく保証サービスを受けることができます。

³No: 除外 - HP製品の一部の部品は、顧客自己修理用ではありません。製品の保証を継続するためには、HPまたはHP正規保守代理店による交換作業が必須となります。部品カタログには、当該部品が顧客自己修理除外品である旨が記載されています。

¹Mandatory: 强制性的 — 要求客户必须自行维修的部件。如果您请求 HP 更换这些部件，则必须为该服务支付差旅费和人工费用。

²Optional: 可选的 — 客户可以选择是否自行维修的部件。这些部件也是为客户自行维修设计的。不过，如果您要求 HP 为您更换这些部件，则根据为您的产品指定的保修服务类型，HP 可能收取或不再收取任何附加费用。

³No: 否 — 某些 HP 部件的设计并未考虑客户自行维修。为了满足客户保修的需要，HP 要求授权服务提供商更换相关部件。这些部件在部件图解目录中标记为“否”。

¹Mandatory: 強制的 — 客戶自行維修所使用的零件是強制的。如果您要求 HP 更換這些零件，HP 將會向您收取此服務所需的外出費用與勞動成本。

²Optional: 選購的 — 客戶自行維修所使用的零件是選購的。這些零件也設計用於客戶自行維修之用。不過，如果您要求 HP 為您更換，則可能需要也可能不需要負擔額外的費用，端視針對此產品指定的保固服務類型而定。

³No: 否 — 某些 HP 零件沒有消費者可自行維修的設計。為符合客戶保固，HP 需要授權的服務供應商更換零件。這些零件在圖示的零件目錄中，被標示為「否」。

¹ Mandatory: 필수 — 고객 셀프 수리가 의무 사항인 필수 부품. 사용자가 HP에 이 부품의 교체를 요청할 경우 이 서비스에 대한 출장비 및 작업비가 청구됩니다.

² Optional: 옵션 — 고객 셀프 수리가 선택 사항인 부품. 이 부품들도 고객 셀프 수리가 가능하도록 설계되었습니다. 하지만 사용자가 HP에 이 부품의 교체를 요청할 경우 사용자가 구입한 제품에 해당하는 보증 서비스 유형에 따라 추가 비용 없이 교체가 가능할 수 있습니다.

³ No: No — 고객 셀프 수리가 불가능하도록 설계된 HP 부품. 이 부품들은 고객 셀프 수리가 불가능하도록 설계되었습니다. HP는 고객 보증을 만족시키기 위해 공인 서비스 제공업체를 통해 부품을 교체하도록 하고 있습니다.

HP contact information

For the name of the nearest HP authorized reseller:

- In the United States, call 1-800-345-1518.
- In Canada, call 1-800-263-5868.
- In other locations, refer to the HP website at <http://www.hp.com/>.

For HP technical support:

- In North America:
 - Call 1-800-HP-INVENT (1-800-474-6836). This service is available 24 hours a day, 7 days a week. For continuous quality improvement, calls may be recorded or monitored.
 - If you have purchased a Care Pack (service upgrade), call 1-800-633-3600. For more information about Care Packs, refer to the HP website at <http://www.hp.com/>.
- Outside North America, call the nearest HP Technical Support Phone Center. For telephone numbers for worldwide Technical Support Centers, refer to the HP website at <http://www.hp.com/>.

Before you contact HP

Be sure to have the following information available before you call HP:

- Technical support registration number (if applicable)
- Product serial number
- Product model name and number
- Applicable error messages
- Add-on boards or hardware
- Third-party hardware or software
- Operating system type and revision level

3 Removal and replacement procedures

This chapter provides subassembly/module-level removal and replacement procedures for the HP ProLiant ML110 Generation 4 server.

Review the specifications of a new component before installing it to make sure it is compatible with the server. When you integrate new components into the system, record its model and serial number, and any other pertinent information for future reference. After completing any removal or replacement procedure, run the diagnostics program to verify that all components operate properly.

Hardware configuration tools

In performing any hardware configuration procedure you may need the following tools:

- T-15 Torx screwdriver
- Flat-blade screwdriver



NOTE: The figures used in this chapter to illustrate procedural steps are labeled numerically (i.e., 1, 2...). When these figures are used in substep items, the alphabetically labeled instructions correspond to the numbered labels on the related figure (i.e., Label 1 corresponds to step a, label 2 corresponds to step b, etc.).

Hardware configuration information



WARNING! Only authorized technicians trained by HP should attempt to repair this equipment. Because of the complexity of the individual boards and subassemblies, no one should attempt to make repairs at the component level or to make modifications to any printed wiring board. Improper repairs can create a safety hazard.



CAUTION: Electrostatic discharge (ESD) can damage electronic components. Be sure that you are properly grounded (earthed) before beginning any installation procedure. Refer to the “Electrostatic Discharge Information” section for more information.

Before removing any serviceable parts, determine whether the part is hot-plug or non-hot-plug.

Non-hot-plug device

If the device is non-hot-plug, you must power down the server. Non-hot-plug devices in the server include the processor, all boards, memory modules, fans, PCI option cards, and all hard drives.

Electrostatic discharge information

ESD can damage static-sensitive devices or microcircuit. Proper packaging and grounding techniques are necessary precautions to prevent damage. To prevent electrostatic damage, observe the following precautions:

- Transport products in static-safe containers such as conductive tubes, bags, or boxes.
- Keep electrostatic-sensitive parts in their containers until they arrive at static-free stations.
- Cover workstations with approved static-dissipating material. Use a wrist strap connected to the work surface and properly grounded (earthed) tools and equipment.
- Keep work area free of nonconductive materials, such as ordinary plastic assembly aids and foam packing.
- Make sure that you are always properly grounded (earthed) when touching a static-sensitive component or assembly.
- Avoid touching pins, leads, or circuitry.
- Always place drives with the Printed Circuit Board (PCB) assembly-side down.
- Use conductive field service tools.

Symbols on equipment

These symbols may be located on equipment in areas where hazardous conditions may exist.

 **WARNING!** This symbol, in conjunction with any of the following symbols, indicates the presence of a potential hazard. The potential for injury exists if warnings are not observed. Consult your documentation for specific details.

 This symbol indicates the presence of hazardous energy circuits or electric shock hazards. Refer all servicing to qualified personnel.

WARNING! To reduce the risk of injury from electric shock hazards, do not open this enclosure. Refer all maintenance, upgrades, and servicing to qualified personnel.

 This symbol indicates the presence of electric shock hazards. The area contains no user or field serviceable parts. Do not open for any reason.

WARNING! To reduce the risk of injury from electric shock hazards, do not open this enclosure.

 This symbol on an RJ-45 receptacle indicates a network interface connection.

WARNING! To reduce the risk of electric shock, fire, or damage to the equipment, do not plug telephone or telecommunications connectors into this receptacle.

 This symbol indicates the presence of a hot surface or hot component. If this surface is contacted, the potential for injury exists.

WARNING! To reduce the risk of injury from a hot component, allow the surface to cool before touching.

 These symbols, on power supplies or systems, indicate that the equipment is supplied by multiple sources of power.

WARNING! To reduce the risk of injury from electric shock, remove all power cords to completely disconnect power from the system.



Weight in kg
Weight in lbs

This symbol indicates that the component exceeds the recommended weight for one individual to handle safely.

WARNING! To reduce the risk of personal injury or damage to the equipment, observe local occupational health and safety requirements and guidelines for manual material handling.

Pre-installation instructions

Perform the steps below before you open the server or before you remove or replace any component:

 **WARNING!** Failure to properly turn off the server before you open it or before you start installing/removing components may cause serious damage as well as bodily harm.

1. Turn off the server and all the peripherals connected to it.
Refer to the Powering down the server section in this chapter for detailed instructions on how to completely power down the server.
2. Unplug all cables from power outlets to avoid exposure to high energy levels that may cause burns if parts are short-circuited by metal objects such as tools or jewelry. If necessary, label each cable for reassembly.
3. Disconnect telecommunication cables to avoid exposure to shock hazard from ringing voltages.
4. Open the server according to the instructions described in the System covers section in this chapter.
5. Follow the ESD precautions listed previously in this chapter when handling a server component.

Post-installation instructions

Observe the following items after installing or removing a server component:

1. Make sure that you install all components according to the described step-by-step instructions.
2. Make sure not to leave loose tools or parts inside the server.
3. Reinstall any expansion board(s), peripheral(s), and system cable(s) that have previously been removed.
4. Reinstall the system covers.

5. Connect all external cables and the AC power cord to the system.
6. Press the power button on the front panel to turn on the server.

CAUTION: Do not operate the server for more than 10 minutes with the access panel and drives removed. Otherwise, improper cooling airflow may damage system components.

Powering down the server

To completely remove all power from the system, disconnect all power cords from the server.

- WARNING!** Hazardous voltages are present inside the server. Always disconnect AC power from the server and other associated assemblies while working inside the unit. Serious injury may result if this warning is not observed.
- WARNING!** To reduce the risk of injury from electric shock, disconnect all power cords to completely remove power from the system.
- WARNING!** To reduce the risk of personal injury from hot surfaces, allow the internal system components to cool before touching them.
- CAUTION:** Protect the server from power fluctuations and temporary interruptions with a regulating uninterruptible power supply (UPS). This device protects the hardware from damage caused by power surges and voltage spikes, and keeps the system in operation during a power failure.
- CAUTION:** The server must always be operated with the system covers on. Proper cooling is not achieved when the system covers are removed.

To power down the server:

1. Shut down server as directed by the operating system documentation.
2. Disconnect the AC power cord from the AC outlet and then from the server.
3. Be sure that the power LED indicator is turned off and that the fan noise has stopped.
4. Disconnect all external peripheral devices from the server.

System covers

The access panel and the front bezel are both detachable. You must remove these system covers before you can remove or replace a server component.

Access panel

CAUTION: You must remove the access panel to access internal components and mass storage devices.

To remove the access panel:

1. Loosen the captive thumbscrew located on the rear edge of the access panel.
2. Slide the panel back about 2.5 cm (1.0 in).

Figure 3-1 Removing the access panel

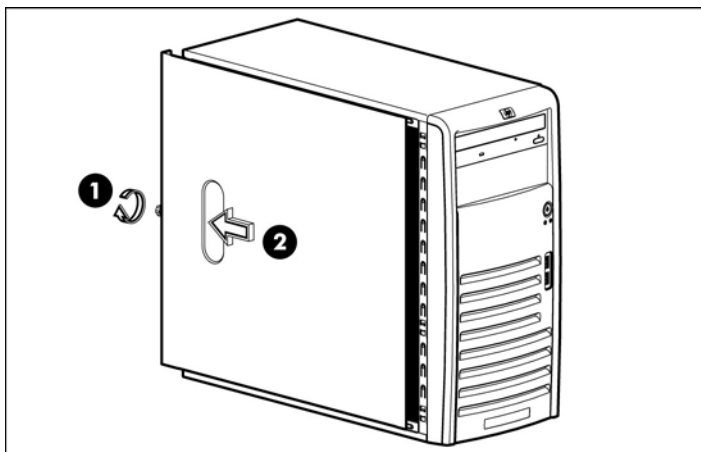

To reinstall the access panel:

1. Use two hands to place the access panel flat against the chassis, the back of the access panel extending about 2.5 cm (1.0 in) behind the back of the server. Make sure the hooks on the access panel align with the holes on the edges of the chassis.
2. Slide the access panel toward the front of the chassis to position it into place.
3. Tighten the captive thumbscrew to secure the access panel.

Figure 3-2 Reinstalling the access panel

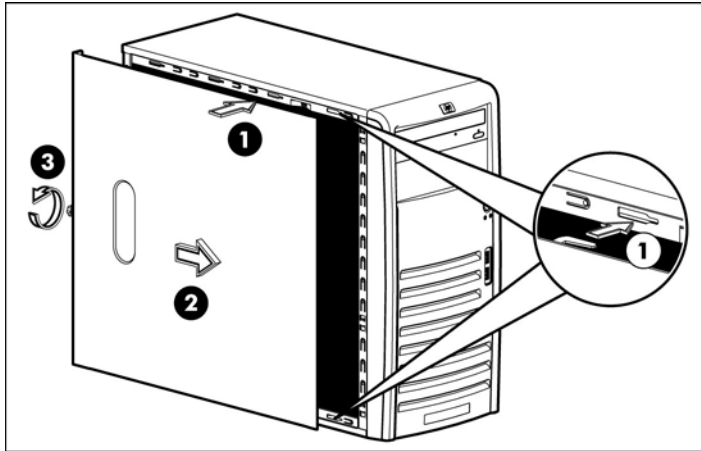

Front bezel

CAUTION: You must remove the front bezel to access the hard drives and optical drives.

To remove the front bezel

1. Remove the access panel.
2. Remove the front bezel:
 - a. Press in the three bottom tabs on the side of the bezel to release them from the chassis.
 - b. Rotate the bezel out slightly.
 - c. Pull the bezel away from the front panel.

Figure 3-3 Removing the front bezel

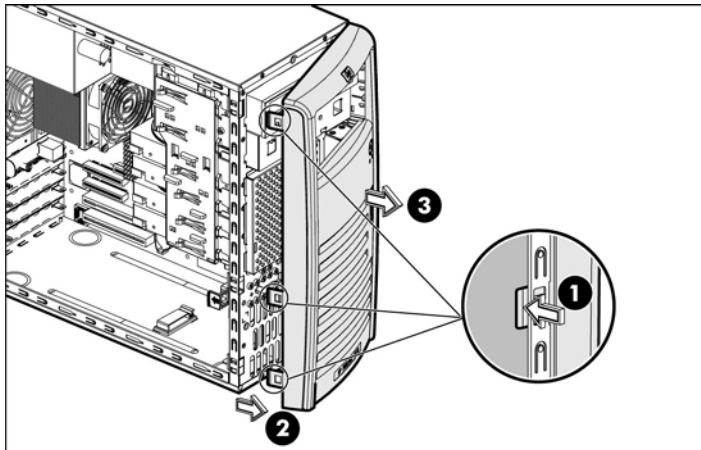

To replace the front bezel:

1. Insert the two hooks on the right side of the bezel into the rectangular holes on the chassis.
2. Rotate the bezel into place so that the three tabs on the left side of the bezel snap into the slots on the chassis.

Figure 3-4 Reinstalling the front bezel

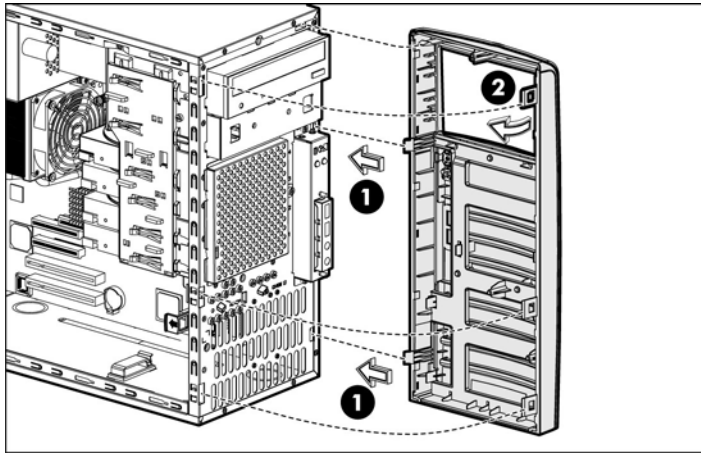

Drives

You can install up to two optical drives and up to four hard drives in the server.

Cable management

Always follow good cable management practices when working inside the computer.

- Keep cables away from major heat sources like the cooler.
- Do not jam cables on top of expansion cards or memory modules. Printed circuit cards are not designed to withstand excessive pressure.
- Keep cables clear of sliding or moveable parts to prevent cutting or crimping.
- When folding a flat ribbon cable, never fold to a sharp crease. Sharp creases may damage the wires.
- Some flat ribbon cables come refolded. Never change the folds on these cables.
- Do not sharply bend any cable. A sharp bend can break the internal wires.
- Never bend a SATA data cable tighter than a 30 mm (1.18 in) radius.
- Never crease a SATA data cable.
- Do not rely on components like the drive cage, power supply, or system cover to push cables down into the chassis.

Removing power supply power cables from the system board connectors (P2, P3) follow below steps:

1. Squeeze on the top of the retaining latch attached to the cable end of the connector.
2. Grasp the cable end of the connector and pull it straight up.

CAUTION: Always pull the connector - NEVER pull on the cable. Pulling on the cable could damage the cable and result in a failed power supply.

Figure 3-5 Unplugging power cables

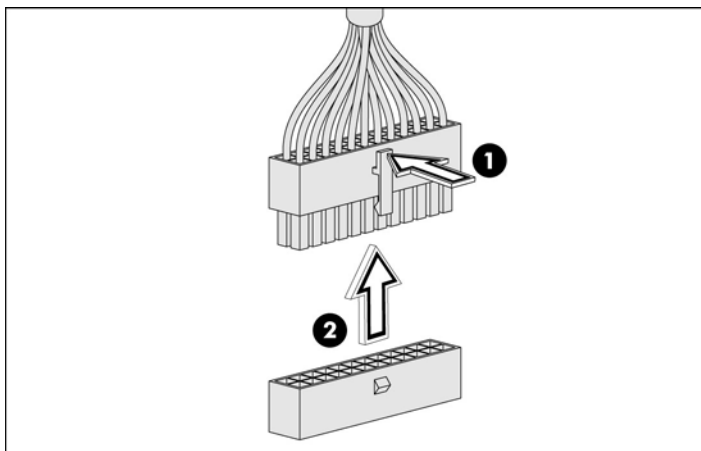

Cable connections

The following table provides information about power supply cable connector labels, as well as system board connector designators. The top half of the table indicates the label on the power supply cable. The bottom half of the table provides the system board designators that various cables plug into. For more detailed information about system board components, see System board components in Chapter 5.

Table 3-1 Cable connections

Cable	To	Cable Designator
Power supply	System board	P1
Power supply	System board CPU power	P2
Power supply	1 st SATA hard drive	P12
Power supply	2 nd SATA hard drive	P10
Power supply	3 rd SATA hard drive	P8
Power supply	4 th SATA hard drive	P6
Power supply	1 st SAS hard drive	P11
Power supply	2 nd SAS hard drive	P9
Power supply	3 rd SAS hard drive	P7
Power supply	4 th SAS hard drive	P5
Power supply	1 st optical drive	P3
Power supply	2 nd optical drive	P4
Cable	To	System board designator
CPU fan connector	System board	P70
Rear system fan	System board	P8
Front USB connector	System board	P24
Front panel connector	System board	P5
1 st SATA connector	System board	P60
2 nd SATA connector	System board	P61
3 rd SATA connector	System board	P64
4 th SATA connector	System board	P62
Internal USB tape drive	System board	J4
Internal USB port	System board	J3

Drive bay configuration

The server supports a maximum of six internal drives. The two upper drive bays are primarily for removable media devices, while the four lower drive bays are only for hard drives. The two upper bays are half height IDE optical bays. The four lower drive bays can accommodate non-hot-plug hard drives.

Figure 3-6 Drive bay configuration

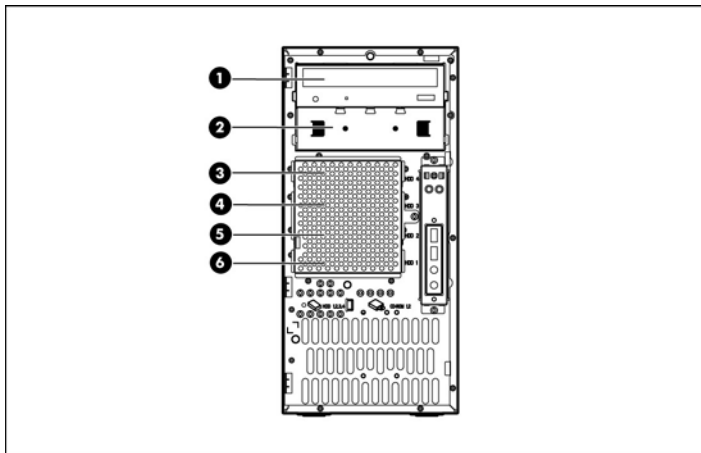

- | | | | |
|---|-------------------------------------|---|-------------------------------------|
| 1 | 1 st Optical drive | 4 | 3 rd SAS/SATA hard drive |
| 2 | 2 nd Optical drive | 5 | 2 nd SAS/SATA hard drive |
| 3 | 4 th SAS/SATA hard drive | 6 | 1 st SAS/SATA hard drive |

Releasing drives

1. A drive latch with release tabs secures the drives in the drive bay. Lift the release tab on the drive latch for the drive you want to remove.
2. Slide the optical drive out from its bay.

Figure 3-7 Releasing drives

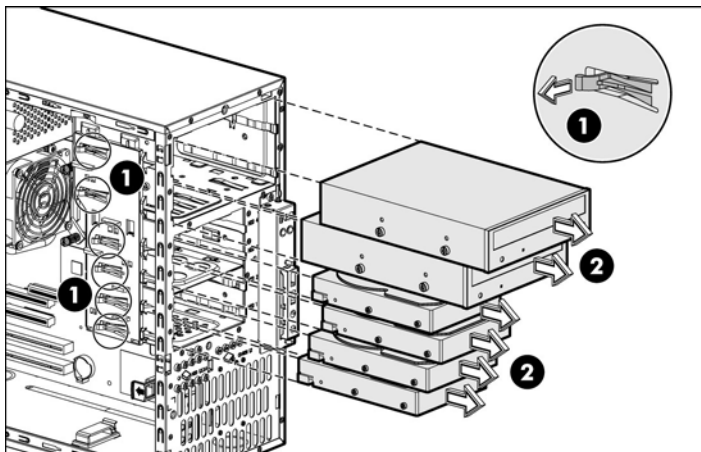

3. When replacing drives, remove the four guide screws (two on each side) from the old drive. You will need these screws to install a new drive.

Optical drive

To replace an optical drive

1. Remove the optical drive from the server:
 - a. Disconnect the power and data cables from the rear of the optical drive.
 - b. A drive latch with release tabs secures the drives in the drive bay. Lift the release tab on the drive latch.
 - c. Slide the drive from the drive bay.

Figure 3-8 Removing an optical drive

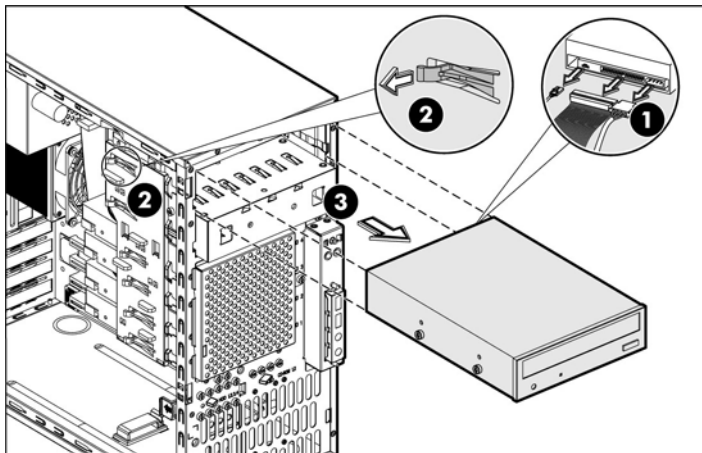

2. Place the old optical drive on a static-dissipating work surface or inside of an anti-static bag.
3. Remove the new optical drive from its protective packaging.
4. Check that the IDE jumper on the rear section of the optical drive is set to Cable-Select mode.
5. Install the new optical drive:
 - a. Insert four screws (two on each side) into the new optical drive.
 - b. Guide the new optical drive into the optical bay, with the cable connectors facing the rear of the chassis, and then push the drive all the way into the drive bay until the drive clicks into place.
 - c. Connect the IDE power and data cables to their connectors on the rear of the drive.

Figure 3-9 Installing an optical drive

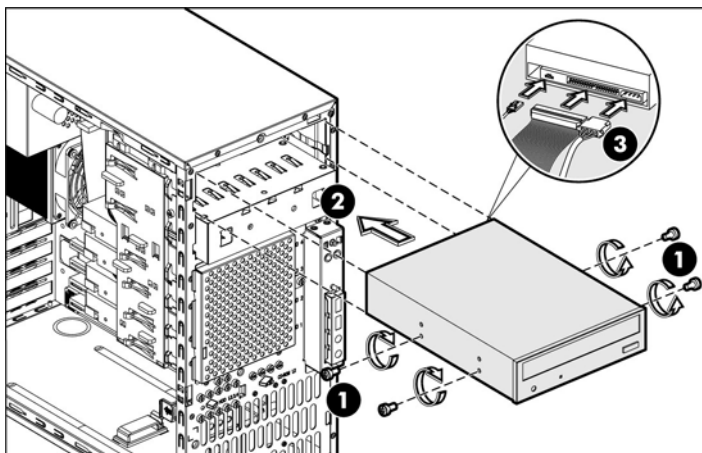

Optional media device

The lower half-height drive bay can be used for an optional optical drive.

To install an optional optical drive

1. Remove the drive shield to prepare the bay for drive installation:
 - a. Remove the screw that secures the drive shield.
 - b. Pull the shield out of the chassis. Store it for later use.



CAUTION: Do not discard the shield. If the drive is removed in the future, you must reinstall the shield to maintain proper system function.

Figure 3-10 Removing the drive shield

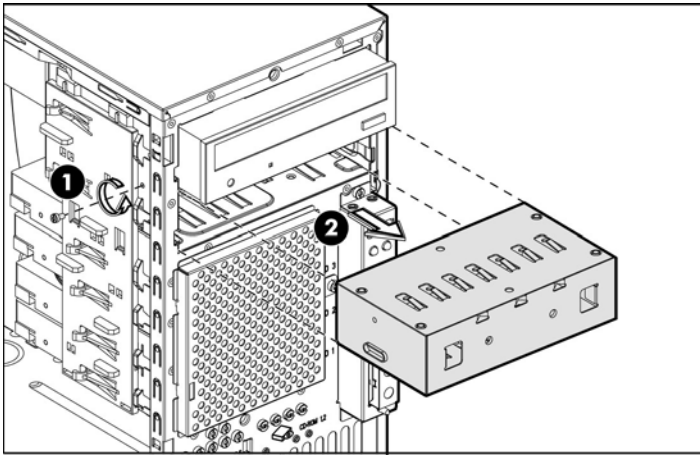

2. Install the new drive:
 - a. Insert four screws (two on each side) into the new optical drive.
 - b. Guide the new drive into the bay, with the cable connectors of the drive facing the rear of the chassis, and then push the drive all the way into the chassis until the drive clicks into place.
 - c. Connect the power and data cables to the connectors on the rear of the drive.

Figure 3-11 Installing an optional media drive

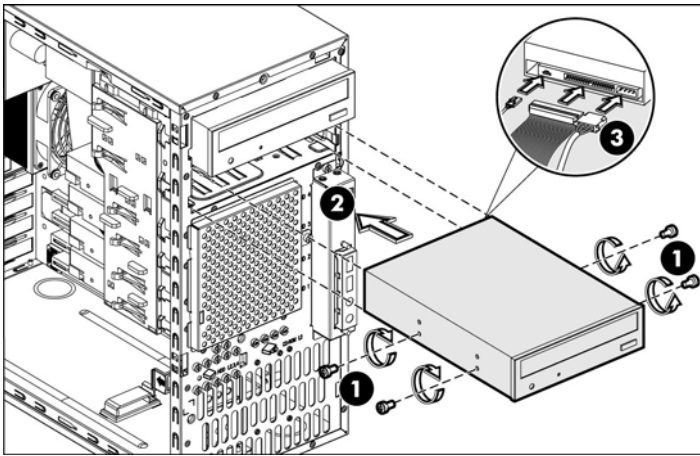

Hard drives

You can install either SAS hard drives or SATA hard drives in the server. The bottom four bays are the hard drive bays.

- CAUTION:** SAS hard drives require that you also install a SAS expansion card. Connect the hard drive data cable from the hard drive to the SAS expansion card. Then connect power cable from the power supply to the back of hard drive. For more information about installing expansion cards, see [Expansion cards](#).

To remove hard drive:

1. Disconnect the power and data cables from the back of the installed drive.
2. A drive latch with release tabs secures the hard drives in the drive bay. Lift the release tab on the drive latch.
3. Slide the hard drive from the drive bay.



NOTE: Remove the four screws from the sides of the drive. You will reuse these screws when you install the new hard drive.

Figure 3-12 Removing a hard drive

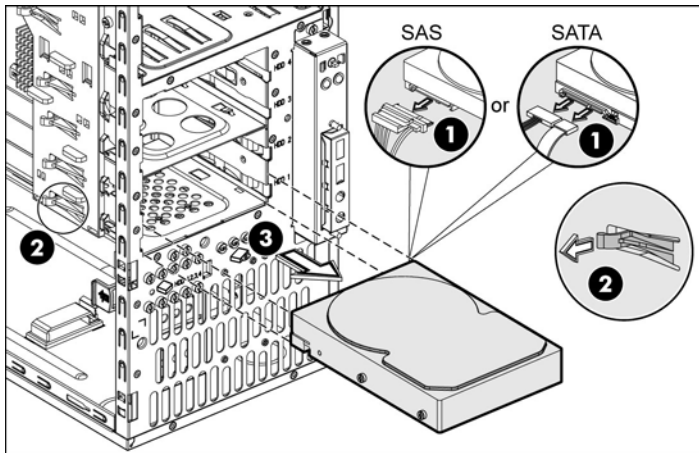

To install the new hard drive:

1. Insert the four drive screws (two on each side) into the hard drive.
2. Slide the new hard drive into the selected bay until it clicks into place.
3. Connect the power cable from the power supply to the back of the hard drive.

Figure 3-13 Installing a hard drive

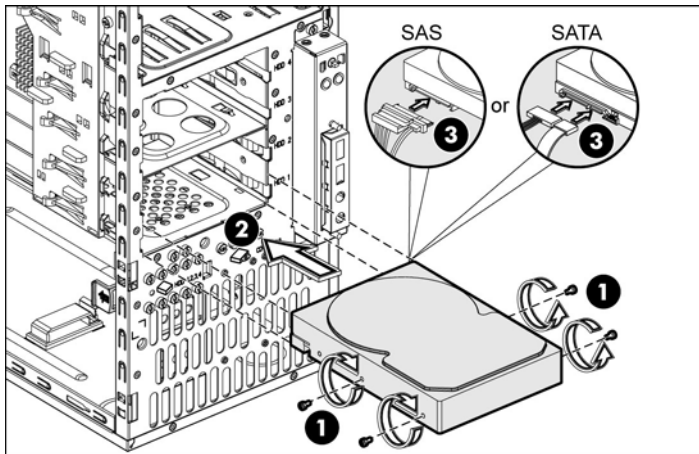

CAUTION: If you are installing a SATA hard drive, connect the data cables from the system board to the back of the hard drive and connect the power cable from the power supply to the back of the hard drive.

CAUTION: If you are installing a SAS hard drive, connect the data cable from the SAS expansion card to the back of the hard drive.

NOTE: If you want to install a new hard drive in an empty drive bay, remove four screws from the front of the chassis labeled 'HDD SCREWS' in the below figure for the location of these spare screws.

Figure 3-14 Drive screw location

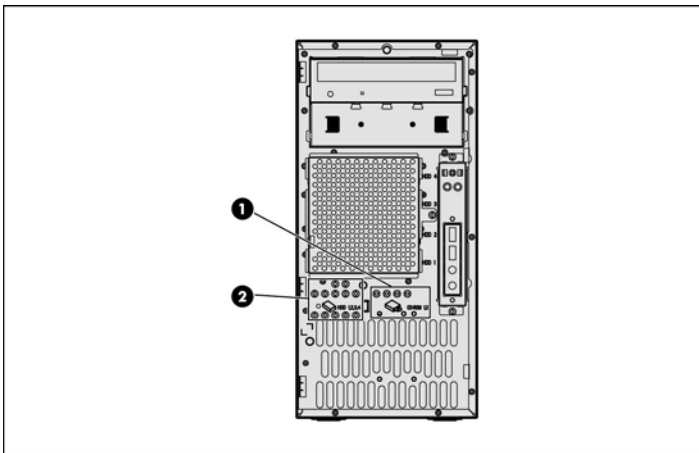

Drive latch

You can remove the latch that secures and allows removal of the drives.

To remove the drive latch:

1. Pull the latch to loosen the two tabs that secure the latch to the chassis.
2. Slide the latch straight down and remove it from the chassis.



NOTE: To loosen the latch, you may also have to pull the tabs that secure inserted drives. Drive latch tabs may break during removal.

Figure 3-15 Removing the drive latch

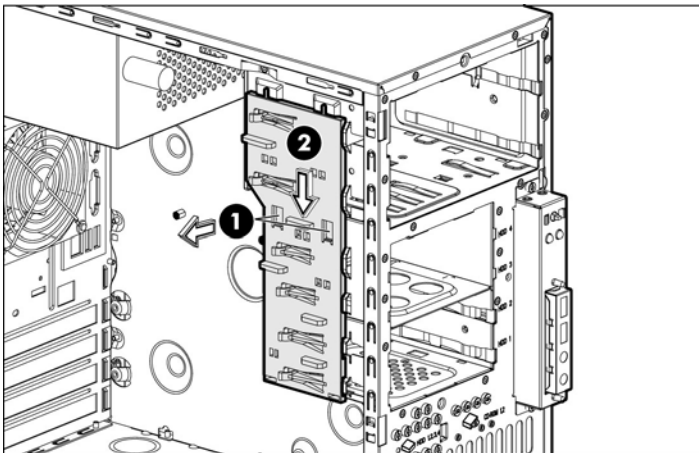

To install new drive latch:

1. Insert the two tabs on the top of the latch into their holders near the top of the chassis.
2. Slide the latch upward until the two tabs in the middle of the latch click into place.

Figure 3-16 Installing the drive latch

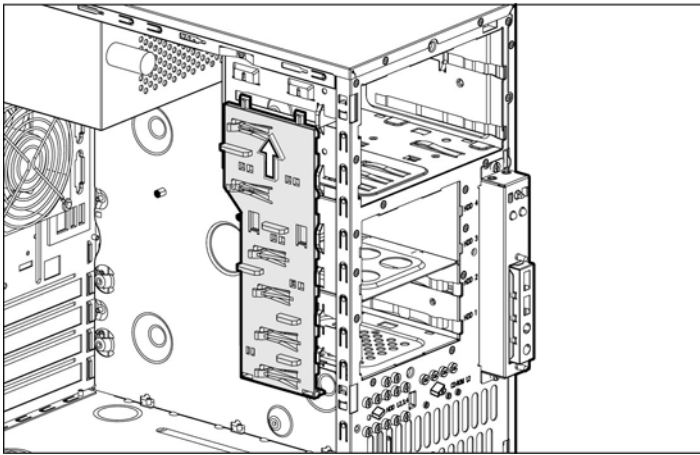

System board components

Refer to the following sections for instructions about how to remove or replace the processor, the memory modules, the expansion cards, and the system battery.

Processor

The LGA775 processor socket supports Intel® Pentium®4, Intel® Pentium® -D, Celeron® -D processors, and Xeon® 3000 series processors.

Figure 3-17 LGA775 processor socket location

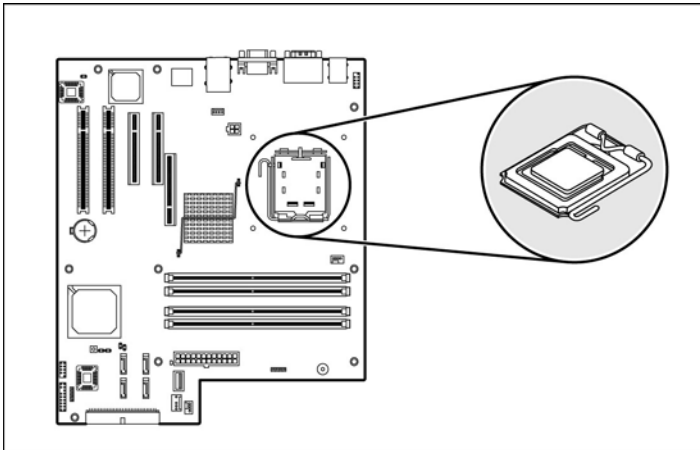

⚠ WARNING! To reduce the risk of injury from a hot component, allow the surface to cool before touching.

To remove cooler assembly:



NOTE: Lay the server on its side with the open side facing up.



NOTE: If necessary, remove any accessory boards or cables that prevent access to the processor socket.

1. Disconnect the processor fan cable from the connector on the system board (P70).
2. Twist the mounting pins counterclockwise to loosen them.
3. After you loosen all four mounting pins, lift cooler away from the system board.

Figure 3-18 Removing cooler assembly

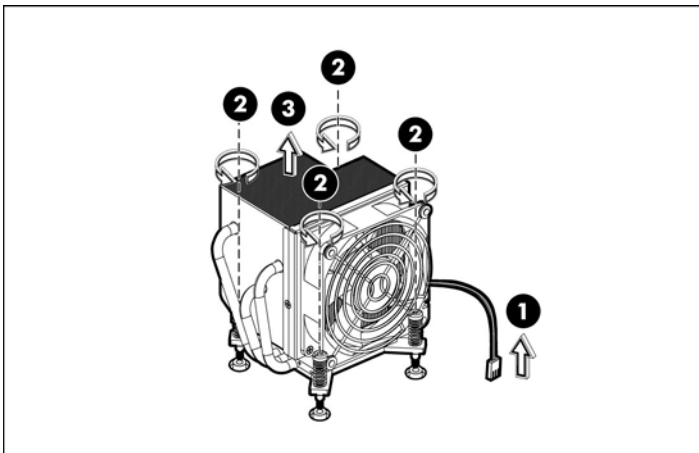

CAUTION: Place cooler down in an upright position with the thermal patch facing upward. Do not let the thermal patch touch the work surface.

To remove the processor:

1. Disengage the load lever.
2. Lift the retention plate to expose the socket body.
3. Grasp the processor by its edges and lift it out of the socket.

Figure 3-19 Removing the processor

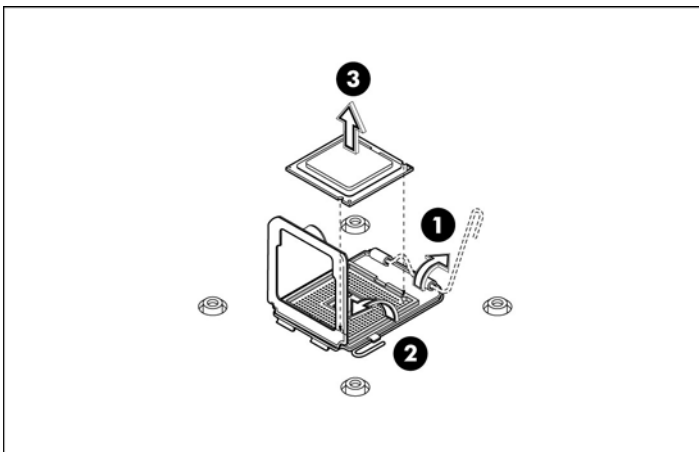

CAUTION: Place the processor on a static-dissipating work surface or in an anti-static bag.

CAUTION: To allow cooler to draw as much heat as possible from the processor base, there must be good contact between the cooler base and the top of the processor. To ensure good contact, you must apply thermal grease compound.

Apply the thermal grease compound:

1. Use a clean cloth dipped in rubbing alcohol to clean the contact surface on the cooler and on the new processor. Wipe the contact surfaces several times to make sure they are free of particles or dust contaminants.
2. Apply the thermal grease compound to the CPU contact surface.
3. Use a proper tool to spread the grease throughout the entire contact surface and **lightly** scrape off any excess grease.

CAUTION: Never touch the bottom side of the processor; any contaminant could prevent the processor contact pads from making contact with the socket.

CAUTION: It is recommended to use the thermal grease of X-23-7783D made by Shin-Etsu.

⚠ CAUTION: Applying too much grease creates a gap between the contact surfaces, significantly reducing the ability of the cooler to draw out heat. Installing the cooler with excessive grease can also cause the grease to spread over the processor pins or the system board base, which can cause electrical shorts that damage the system.

To install the new processor:

1. With the load lever and the retention plate disengaged, hold the processor by its edges and align it over the empty processor socket. Make sure that you properly align the processor with the orientation notch on the socket.
2. Insert the processor into the socket.
3. Engage the retention plate.
4. Engage the load lever.

Figure 3-20 Installing a processor

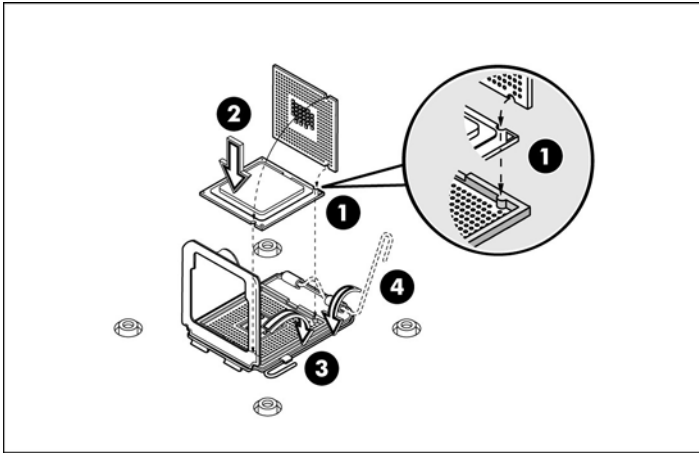

⚠ CAUTION: After you install the processor, you must reinstall the cooler on top of the processor socket. The thermal grease you applied on the contact surfaces of the cooler and the processor provides the necessary thermal bonding to allow the cooler to draw heat from the processor.

⚠ CAUTION: To prevent processor overheating or system instability, use only a cooler assembly specified for the HP ProLiant ML110 Generation 4 server.

To replace cooler assembly:

1. Properly align the cooler mounting pins to the system board mounting holes and press down until you hear a click.
 2. Twist the mounting pins clockwise to secure the cooler connection to the system board.
 3. Connect the processor fan cable to the connector on the system board (P70).
-

⚠ CAUTION: Failure to connect the processor fan cable to the system board may result in damage to the processor and could cause the server to shut down without displaying messages.

Figure 3-21 Installing the cooler assembly

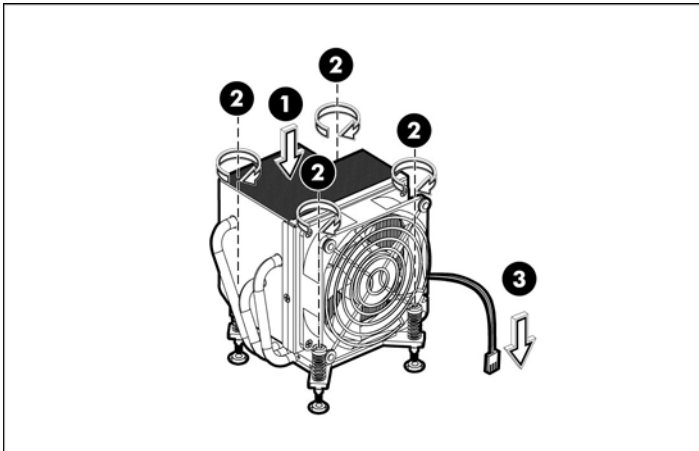

Memory

The HP ProLiant ML110 Generation 4 server has four DIMM slots that support up to 8 GB maximum system memory (2 GB in each of the four DIMM slots).

Figure 3-22 DIMM slots location

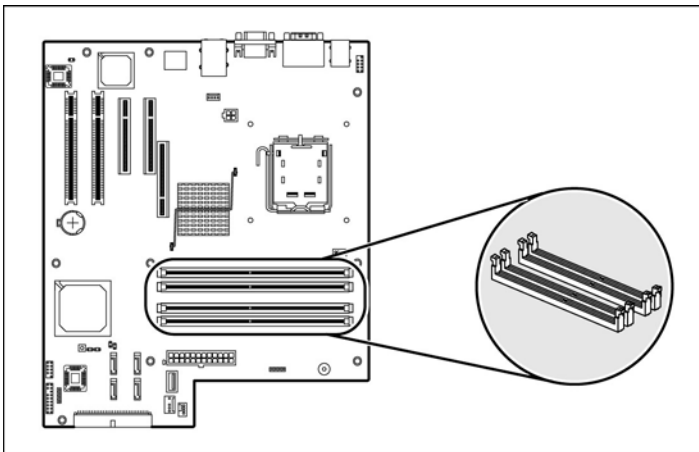

Guidelines for installing memory modules

You must adhere to the following guidelines when adding or replacing memory modules:

- Use only DDR II 533/667 unbuffered ECC DIMMs in 512 MB, 1 GB or 2 GB module.
- Up to two DIMMs per channel, single-sided and/or double-sided. Channel A corresponds to the DIMM1 and DIMM2 slots, while channel B corresponds to the DIMM3 and DIMM4 slots.
- For optimal 2 DIMMs configuration, populate slot 1 and slot 3. Identical DIMMs are recommended.

To remove memory module:



NOTE: Lay the server on its side with the open side facing up.



NOTE: If necessary, remove any accessory boards or cables that prevent access to the processor socket.

1. Completely open the holding clips securing the module.
2. Gently pull the memory module upward to remove it from the socket.

Figure 3-23 Removing a memory module

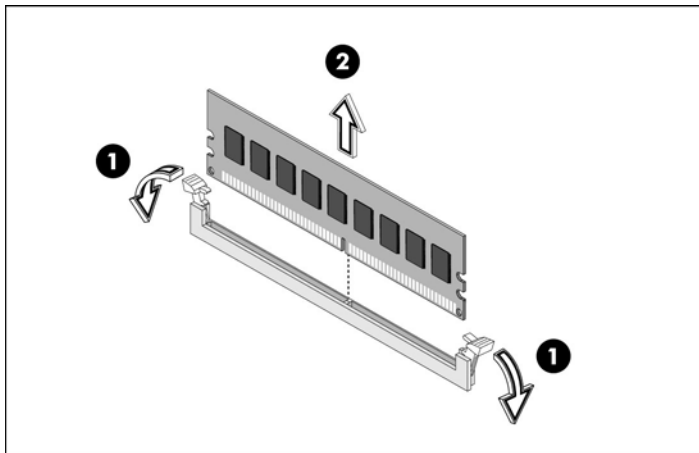

CAUTION: Place the memory module on a static-dissipating work surface or inside of an anti-static bag.

To install a memory module:

1. Orient the module so that the notch on the bottom edge of the module aligns with the keyed surface of the DIMM socket, and then press it fully into the socket.
2. Firmly press the latches inward to secure the memory module in place.

Figure 3-24 Installing a memory module

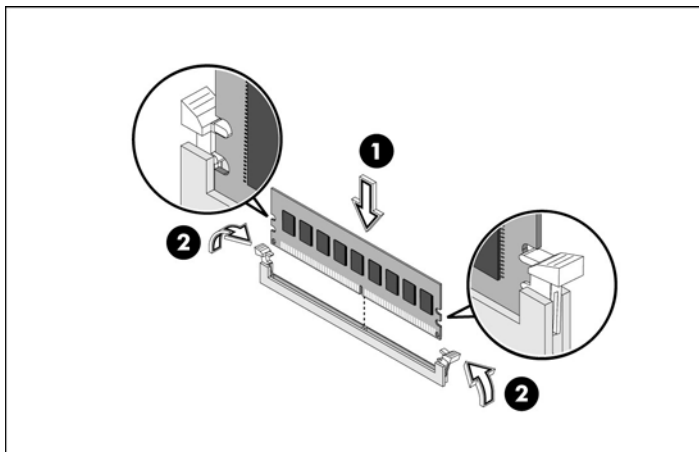

CAUTION: The memory sockets are structured to ensure proper installation. If you insert a memory module but it does not fit easily into the socket, you may have inserted it incorrectly. Double-check the orientation of the module and reinsert. If the latches do not close, the module is not inserted correctly.

Expansion cards

PCI card

You must remove the PCI expansion slot cover lock before installing or removing expansion cards.

The server supports the following:

- Two 32-bit/33-MHz 3.3V PCI slots (J20 to J21)
- One PCI-Express x4 link with x8 slot (J33)
- One PCI Express x8 link with x8 slot (J32)

Figure 3-25 PCI slot location

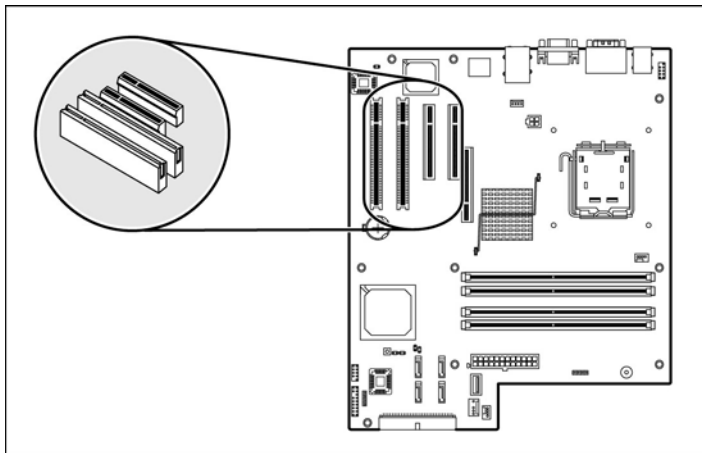

To remove the PCI slot cover lock:

1. Remove the retaining screw that secures the lock to the chassis.
2. Remove the slot cover lock from the chassis.

Figure 3-26 Removing the PCI slot cover lock

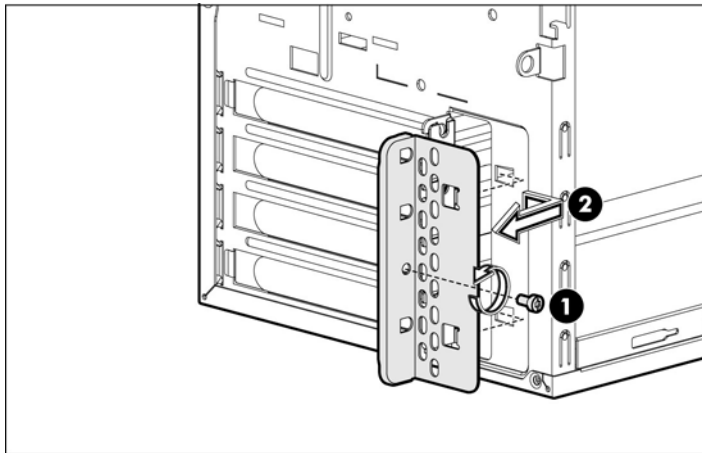

3. Remove the PCI bracket from the chassis.



NOTE: If necessary, remove any accessory boards or cables that prevent access to the PCI slots.



CAUTION: Do not discard the PCI bracket. If the PCI expansion card is removed in the future, the PCI bracket must be reinstalled.

To remove the PCI card:

1. Hold the card at both ends, and then carefully rock the card back and forth until the expansion cards pull free from the slot.
2. Store the old card in the anti-static packaging.

Figure 3-27 Removing the PCI card

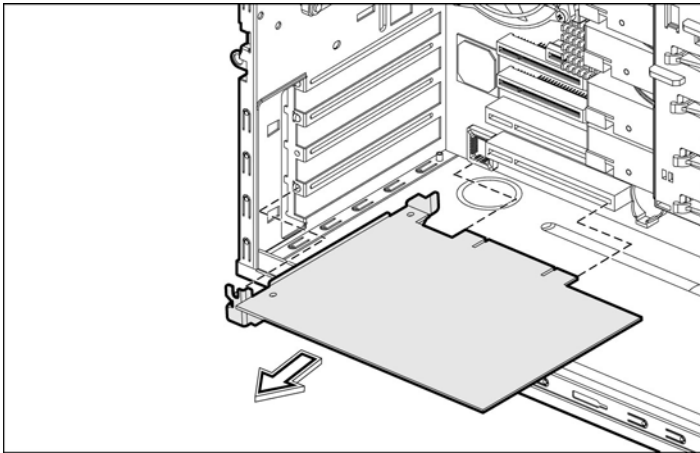

To install the PCI card:

1. Hold the card above the expansion slot on the system board, and then move the card toward the rear of the chassis so that the bracket on the card is aligned with the open slot on the rear of the chassis.
2. Press the card straight down into the expansion slot on the system board.

Figure 3-28 Installing a PCI card

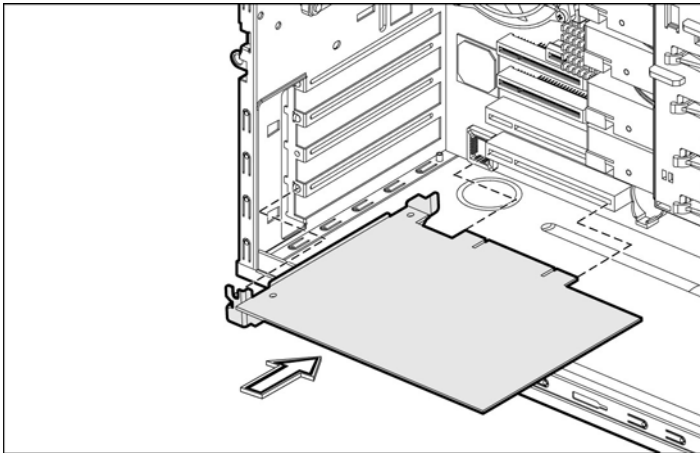

3. Replace the PCI slot cover lock:
 - a. Slide the PCI slot cover lock onto the rails toward the server.
 - b. Replace the slot cover lock retaining screw.

Figure 3-29 Replacing the PCI slot cover

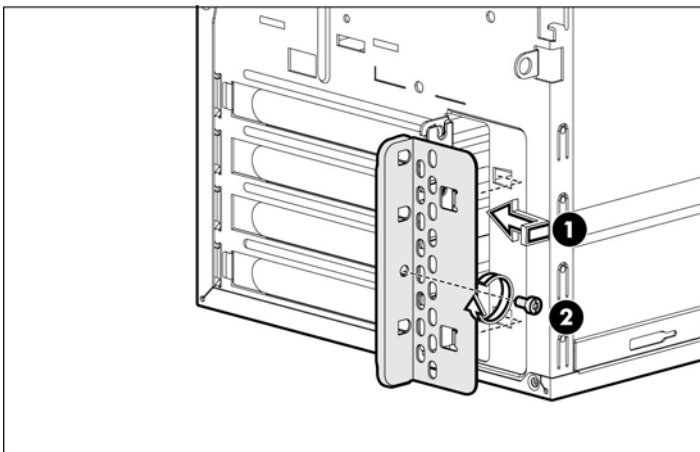

4. Connect required cables to the card.

HP Smart Array E200 controller card

You must remove the PCI expansion slot cover lock and the PCI guide before installing HP Smart Array E200 controller card.

Figure 3-30 HP Smart Array E200 controller card slot location

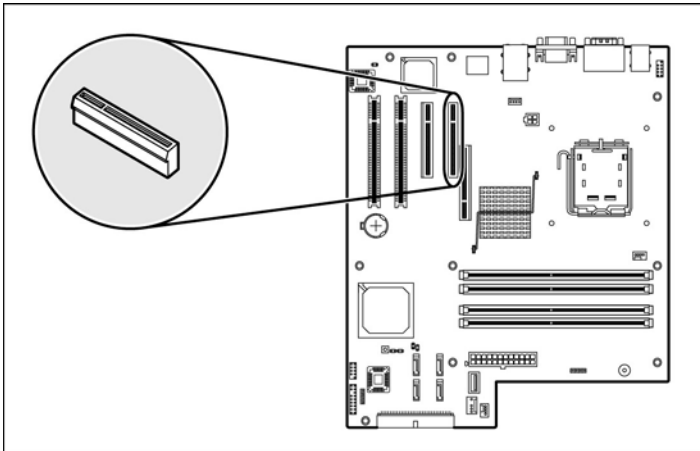

To remove the PCI slot cover lock:

1. Remove the retaining screw that secures the lock to the chassis.
2. Remove the slot cover lock from the chassis.

Figure 3-31 Removing the PCI slot cover lock

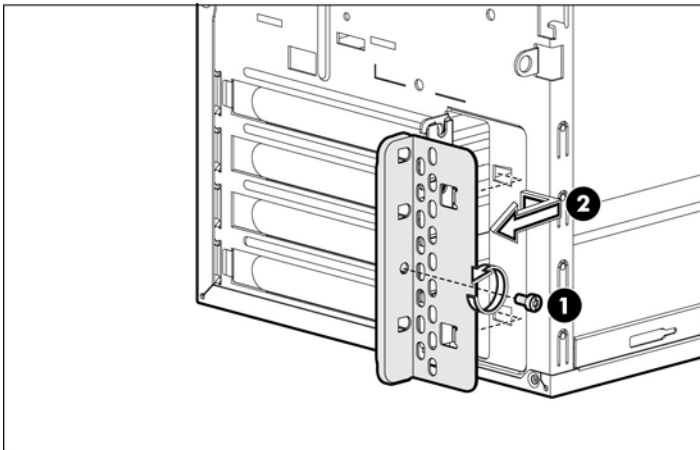

3. Remove the PCI bracket from the chassis.



NOTE: If necessary, remove any accessory boards or cables that prevent access to the PCI slots.



CAUTION: Do not discard the PCI bracket. If the PCI expansion card is removed in the future, the PCI bracket must be reinstalled.

To remove the PCI guide:

1. Remove the PCI guide from the hard drive support to prepare for the HP Smart Array E200 controller card installation.
2. Pull the PCI guide from the hard drive cage support as shown in the below figure.

Figure 3-32 Removing the PCI guide

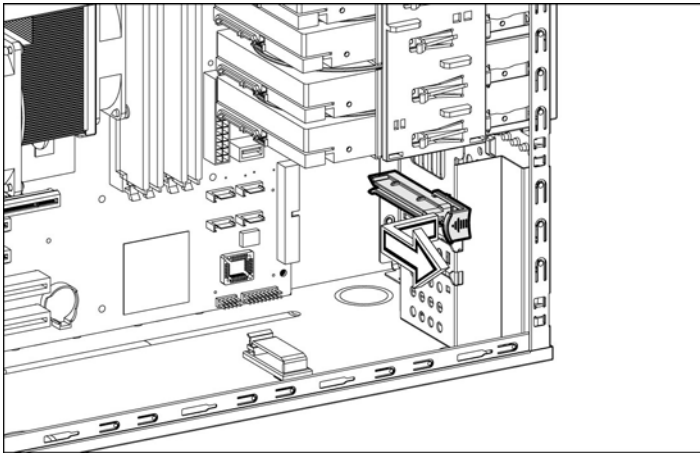

To install a HP Smart Array E200 controller card:

1. Hold the card above the expansion slot on the system board, and then move the card toward the rear of the chassis so that the bracket on the card is aligned with the open slot on the rear of the chassis.
2. Press the card straight down into the expansion slot on the system board.

Figure 3-33 Installing a HP Smart Array E200 controller card

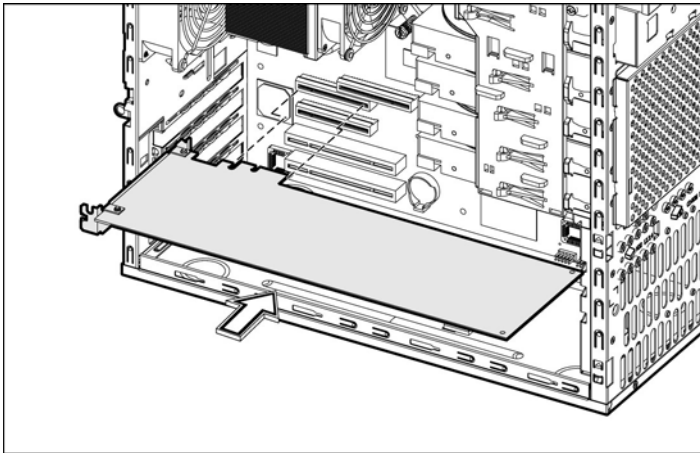

3. Reinstall the PCI guide to secure the HP Smart Array E200 controller card:
 - a. Properly align the PCI guide to the edge of HP Smart Array E200 controller card and hard drive support.
 - b. Slide the PCI guide around the edge of HP Smart Array E200 controller card, and slide the other side of PCI guide inside the hard drive support until the PCI guide click into place.

Figure 3-34 Reinstalling the PCI guide

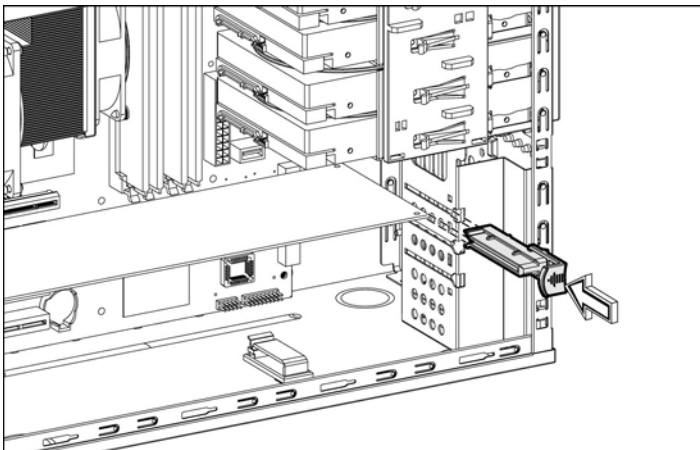

4. Replace the PCI slot cover lock:

- a. Slide the PCI slot cover lock onto the rails toward the server.
- b. Replace the slot cover lock retaining screw.

Figure 3-35 Replacing the PCI slot cover

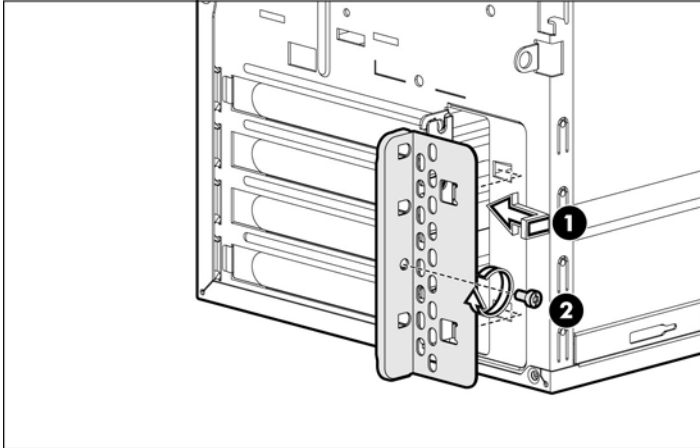

5. Connect required cables to the card.

System battery

The server uses volatile memory that requires a battery to retain system information when power is removed. This 3-volt lithium coin cell battery is located on the system board.

Figure 3-36 System battery location

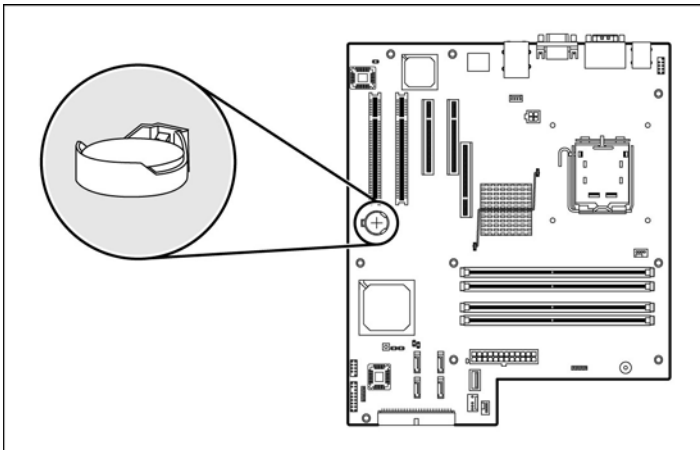

If the server no longer automatically displays the correct date and time, you may need to replace the system battery. Under normal use, battery life is five to ten years.

⚠ WARNING! Note the following reminders when replacing the system battery:

- Replace the battery with the same type as the battery recommended by HP. Use of another battery may present a risk of fire or explosion.
- A risk of fire and chemical burn exists if the battery is not handled properly. Do not disassemble, crush, puncture, or short external contacts, or expose the battery to temperatures higher than 60°C (140°F).
- Do not dispose of used battery in water or fire. Dispose of used batteries according to the manufacturer's instructions.

⚠ CAUTION: Loss of BIOS settings occurs when the battery is removed. You must reconfigure BIOS settings whenever you replace the battery.

To replace the system battery:



NOTE: Lay the server on its side for better access to the battery holder (XBT2).



NOTE: If necessary, remove any accessory boards or cables that prevent access to the battery holder.

1. To release the battery from its holder, squeeze the metal clamp that extends above one edge of the battery. When the battery pops up, lift it out.

2. To insert the new battery, slide one edge of the replacement battery under the holder's lip with the positive side up. Push the other edge down until the clamp snaps over the other edge of the battery.

Figure 3-37 Replacing the battery

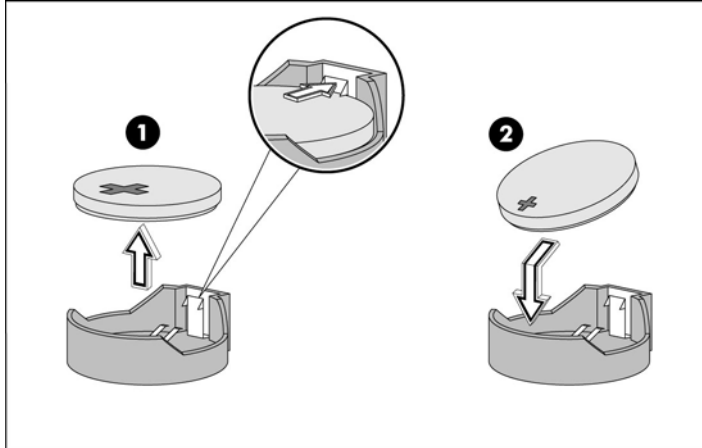

Power supply unit (PSU)

Located on the rear panel of the server power supply is a single standard auto-range 370-watt PSU with PFC (power factor correction) function.

⚠ WARNING! Note the following reminders are to reduce the risk of personal injury from electric shock hazards and/or damage to the equipment.

- Installation of power supply units should be referred to individuals who are qualified to service server systems and are trained to deal with equipment capable of generating hazardous energy levels.
- DO NOT open the power supply unit. There are no serviceable parts inside it.

To remove the power supply:

📝 NOTE: Lay the server on its side with the open side facing up.

1. Disconnect the power cables of all installed drives from the PSU.
2. Remove the four screws that secure the PSU to the chassis.
3. Lift the PSU out of the chassis.

Figure 3-38 Removing the PSU

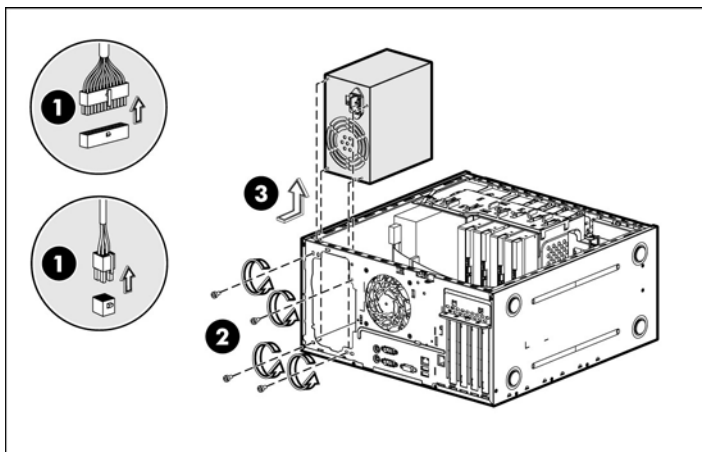

To install new PSU:

1. Align the new PSU to the support edges inside of the chassis.
2. Secure the PSU to the chassis using four screws.
3. Reconnect the processor and system board power cables to the system board connectors (P2, P3), and then connect the power cables to all installed drives.

Figure 3-39 Installing the PSU

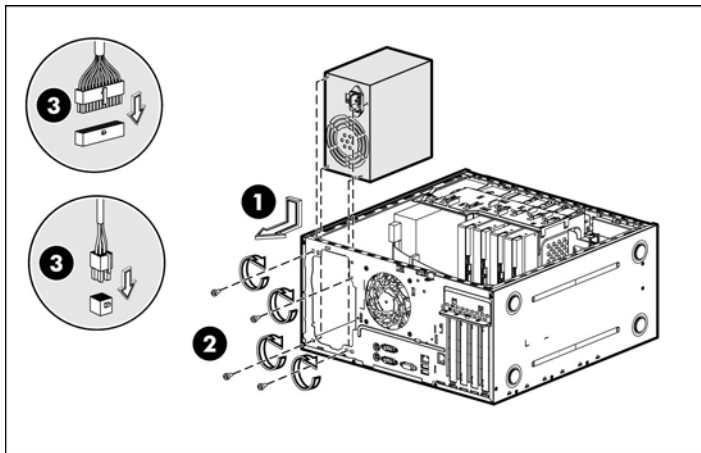

System fan

A new system fan can be installed to allow the server to operate properly in case the default system fan becomes defective.

To remove the system fan:

⚠ WARNING! Be sure to support the system fan with your hand when removing screws from the chassis. The fan could fall onto the system board or an accessory board causing damage if not supported.

1. Disconnect the system fan cable from its connector (P8) on the system board.
2. Remove the four screws from the rear of the chassis that secure the fan.
3. Remove the fan from the chassis.

Figure 3-40 Removing the system fan

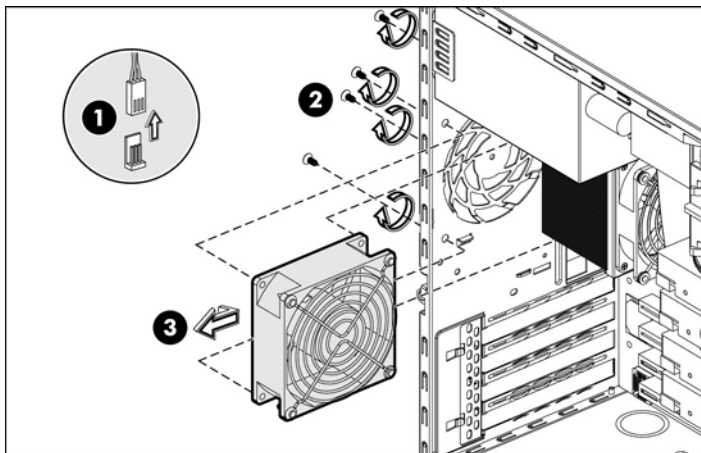

To install new system fan:

1. Align the new fan to the screw holes inside of the chassis.
2. While holding the new fan against the chassis, replace the four screws that secure the fan to the chassis.
3. Connect the system fan cable to its connector (P8) on the system board.

Figure 3-41 Installing the system fan

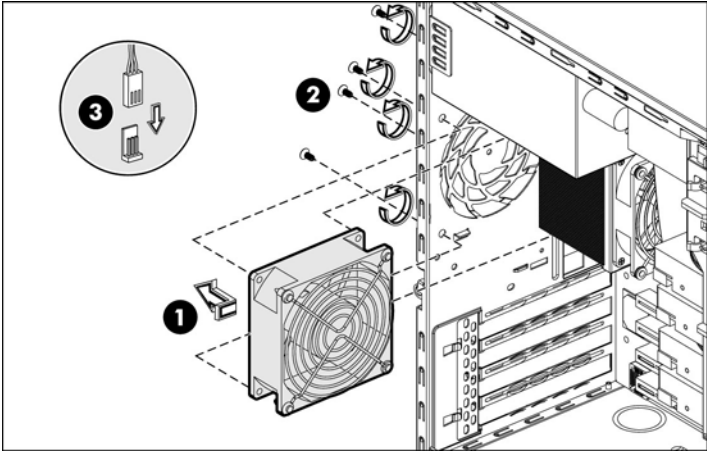

Install IPMI Card

IPMI card (HP Lights-Out 100c remote management card) is a suite of products that enable remote management of ProLiant 100c Series servers. IPMI card allows customers or their service providers to remotely manage ProLiant ML110 G4 servers over a LAN or the Internet. With IPMI card, users can access a system's text console, control system power, and monitor system environmental conditions from a browser or command line.

Figure 3-42 IPMI card connector location

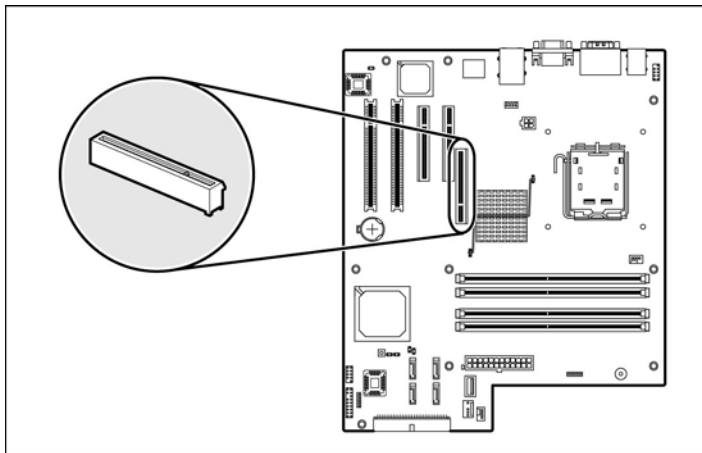

CAUTION: PCIe x8 Connector is only for HP ProLiant ML110 Generation 4 IPMI card.

To install the IPMI card:

1. Back up the server data.
2. Shut down the operating system in an orderly manner, as directed in the operating system instruction.
3. If the server is on, press the power button to power down the server.
4. All power cords must be disconnected.
5. Remove the access panel.
6. Loosen the screw to remove the IPMI card bracket dummy from the chassis.
7. Press the card straight down into the expansion slot on the system board.
8. Be sure the card is at the correct position and the bracket on the card is aligned with the open slot on the rear of the chassis.
9. Fasten the expansion card bracket on the rear panel with screw.

Figure 3-43 Installing the IPMI card

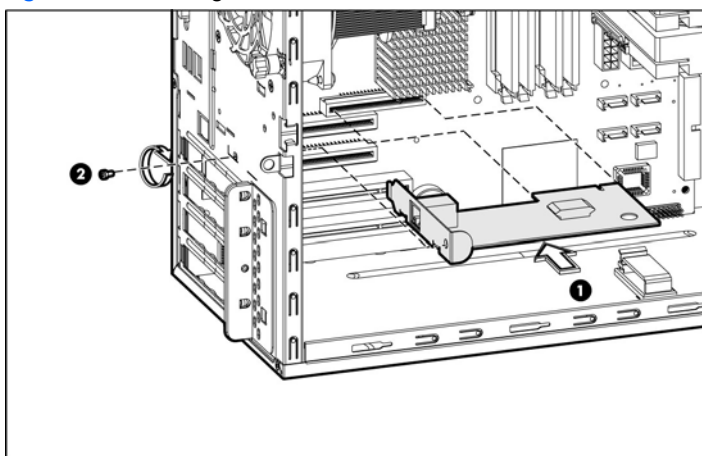

10. Replace the access panel.
11. Reconnect all power cords.

CAUTION: The LAN port on the IPMI card is dedicated to LO100c 10/100 LAN Management Port.

4 Diagnostic tools and Setup Utilities

This chapter provides an overview of the Power-On Self-Test (POST), the POST error messages, and BIOS, SAS and SATA setup utilities.

BIOS Software

The Generation 4 server uses BIOS to boot up the system. BIOS software is a ROM BIOS-based firmware that allows reliability, manageability, and connectivity for server platforms. This software contains a set of programs permanently stored in an EEPROM chipset located on the system board. These programs assist in managing, initializing, and testing the hardware devices installed on the computer.

BIOS software allows you to:

- Perform configuration from the BIOS Setup Utility
Using the Setup Utility, you can install, configure, and optimize the hardware devices on the system board. In addition, you can enable various features such as serial console redirection, PXE boot, and much more.
- Initialize hardware at boot up using POST routines
During power-on or warm reset, the BIOS perform Power-On Self-Test (POST) routines to test system components, to allocate resource for various hardware devices, and to prepare the system to boot to various operating systems.

BIOS Setup Utility

The HP server BIOS Setup Utility is used to configure five primary menu selections :

- Main
- Advanced
- Security
- Boot
- Exit

Accessing the BIOS Setup Utility

1. Turn on the monitor and server. If the server is already turned on, save your data and exit all open applications, then restart the server.
2. When the HP logo is displayed during POST, press **F10**. If you fail to press **F10** before POST is completed, you will need to restart the server.
3. The first page displayed is the Main menu showing the Setup Utility menu bar. Use the left (←) and right (→) arrow keys to move between selections on the menu bar. Use the up (↑) and down (↓) arrow keys to select items within a menu.

Navigating through the Setup Utility

Use the keys listed in the legend bar on the right of the Setup screen to navigate through the various menu and submenu screens of the Setup Utility. Table 4-1 lists these legend keys and their respective functions.

Table 4-1 Setup Utility Navigation Keys

Key	Function
← and →	To move between selections on the menu bar.
↑ and ↓	To move the cursor to the field you want. The currently selected field is highlighted. The right side of each menu screen displays a field help panel—Item Specific Help panel. This panel displays the help text for the currently selected field. It updates as you move the cursor to each field

Table 4-1 Setup Utility Navigation Keys

Key	Function
+ (or F6), - (or F5) and <Space>	To select a value for the currently selected field (only if it is user-configurable). Press the (+), (-) or <Space> keys repeatedly to display each possible entry, or the Enter key to choose from a pop-up menu. A parameter that is enclosed in square brackets is user-configurable. Grayed-out parameters are not user-configurable for one of the following reasons: <ul style="list-style-type: none"> • The field value is auto-configured or auto-detected. • The field value is informational only. • The field is password-protected.
Enter	To select a field value or display a submenu screen. Displays more option for items marked with ►
Ctrl+Enter	To expands all device list
Esc or <Alt+X>	If you press this key: <ul style="list-style-type: none"> • On one of the primary menu screens, the Exit menu displays. • On a submenu screen, the previous screen displays. • When you are making selections from a pop-up menu, the pop-up closes without making a selection.
F1 or <Alt+H>	To bring up the General Help window. The General Help window describes other Setup navigation keys that are not displayed on the legend bar.
<Page Up> and <Page Down>	Moves to previous/next page on scrollable menus.
<Home> and <End>	Moves to top/bottom item of current menu.
F9	To load default system values.
F10	To save changes and close the Setup Utility.

Figure 4-1 Setup Utility General Help screen

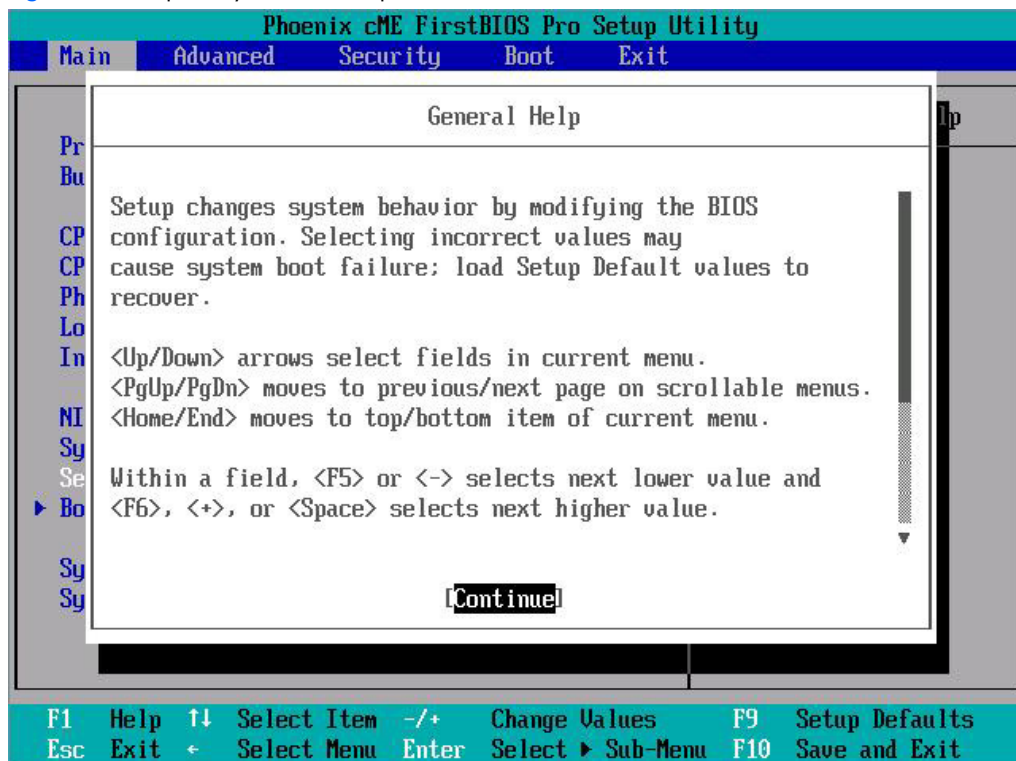

Press **F1** to get the general help message box.

Setup Utility Menu Bar

The BIOS Setup Utility provides a menu bar with the menu selections. The menu bar choices are described in the topics below.

Main Menu

Figure 4-2 Main menu of the BIOS Setup Utility

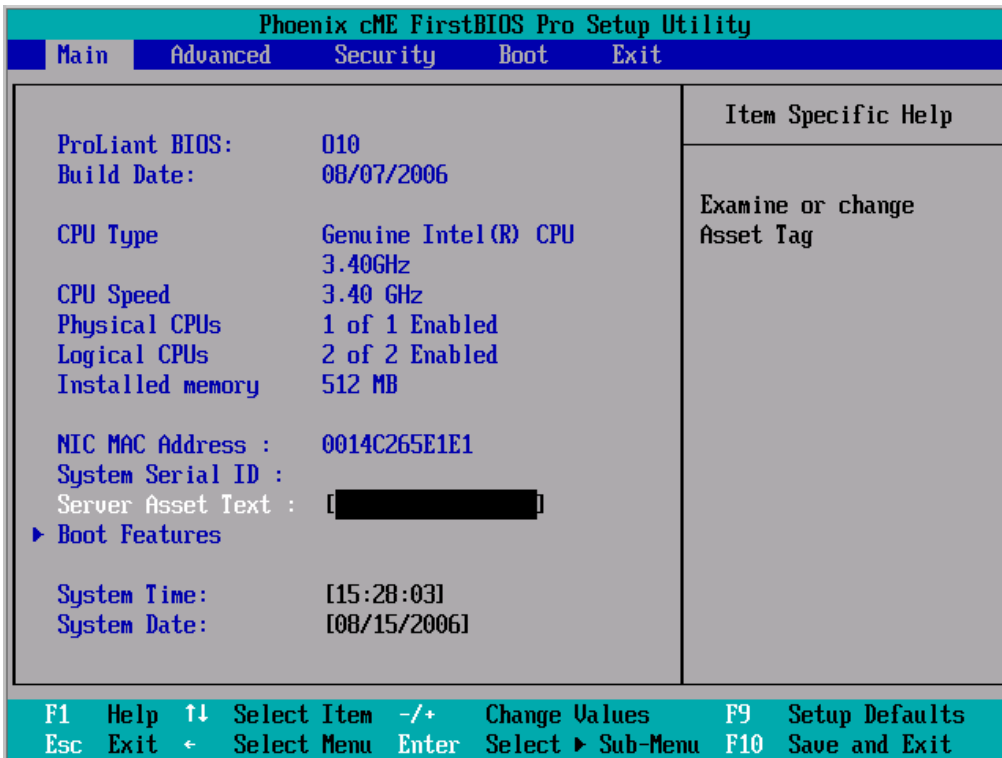

Use this menu to set the system time and date, and configure the following items:

- Set system time and date.
- Set boot features:
 - a. Enable or disable the BIOS summary display.
 - b. Turn on or off boot up Num Lock.
 - c. Set restore on AC power loss options, such as last state, power off, and power on.
 - d. If BIOS displays an error message, set POST F1 Prompt for selections, such as delayed, enabled, or disabled.
- View CPU type / CPU speed information.
- View Installed memory size.
- View MAC address for the embedded NIC.
- View System serial ID.
- Set Server Asset Text.

Advanced Menu

Figure 4-3 Advanced menu of the BIOS Setup Utility

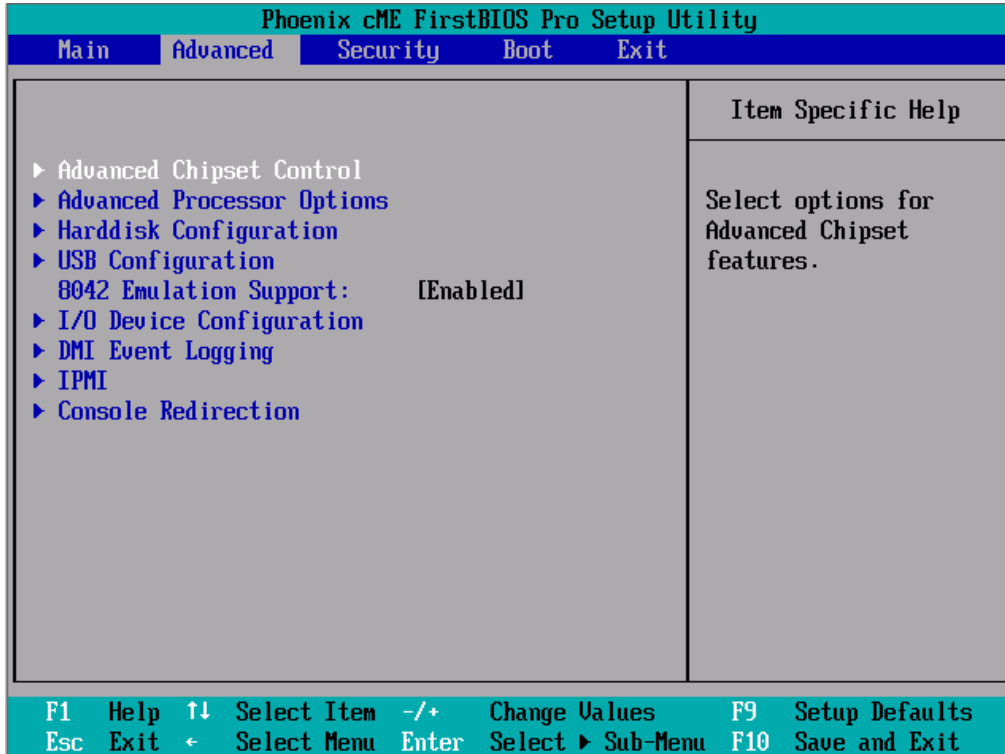

WARNING! Incorrect settings may cause the server to malfunction. To correct the settings, press **F9** key to restore the default settings.

- **Advanced Chipset Control** — Configure the advanced chipset control settings such as the SATA controller mode.
- **Advanced Processor Options** — Enable or disable single logical processor and Intel Virtualization technology for the processor supported.
- **Harddisk Configuration** — Configure the hard disk settings of the server.
View CD-ROM status and SATA hard drive status.
- **USB Configuration** — Configure the USB settings of the server.
- **8042 Emulation Support** — Normally enabled. Disable for Red Hat Linux 64bit installation.
- **I/O Device Configuration** — Configure the serial port settings of the server.
- **DMI Event Logging** — Allow you to view the DMI event log, clear the log, enable or disable this feature, and mark the event as read.
- **Embedded NIC PXE** — Enable or disable PXE boot support.
- **IPMI** — Configure the Intelligent Platform Management Interface (IPMI) settings.
- **Console Redirection** — Configure the settings when redirect the console to a serial port.

IPMI Submenu

Figure 4-4 IPMI submenu of the BIOS Setup Utility 1

Phoenix cME FirstBIOS Pro Setup Utility			
Advanced			
IPMI		Item Specific Help	
IPMI Specification Version	2.0	Enable/Disable IPMI event logging. Disabling will still log events received via the system interface.	
BMC Firmware Version	1.14		
BMC Firmware Date	Aug 11 2006		
System Event Logging	[Enabled]		
Clear System Event Log	[Disabled]		
Existing Event Log number	9		
Remaining Event Log number	374		
Event Log Control			
SYS Firmware Progress	[Disabled]		
BIOS POST Errors	[Enabled]		
BIOS POST Watchdog	[Enabled]		
OS boot Watchdog	[Enabled]		
Timer for loading OS (min)	[10]		
Time out action	[No Action]		
Serial port assignment	[System]		
F1 Help ↑↓ Select Item -/+ Change Values F9 Setup Defaults Esc Exit ← Select Menu Enter Select ▶ Sub-Menu F10 Save and Exit			

Figure 4-5 IPMI submenu of the BIOS Setup Utility 2

Phoenix cME FirstBIOS Pro Setup Utility			
Advanced			
IPMI		Item Specific Help	
Serial port assignment	[System]	DHCP IP Source.	
Serial port switching	[Enabled]		
Serial port connection mode	[Direct]		
Date Format to show	[MM DD YYYY]		
Date Separator	[/]		
▶ System Event Log			
▶ System Event Log (list mode)			
▶ Realtime Sensor Data			
Share NIC Mode	[Disabled]		
DHCP IP Source	[Enabled]		
IP Address	[010.141.038.134]		
IP Subnet Mask	[255.255.255.000]		
Default Gateway	[010.141.038.001]		
F1 Help ↑↓ Select Item -/+ Change Values F9 Setup Defaults Esc Exit ← Select Menu Enter Select ▶ Sub-Menu F10 Save and Exit			

Security Menu

Figure 4-6 Security menu of the BIOS Setup Utility 1

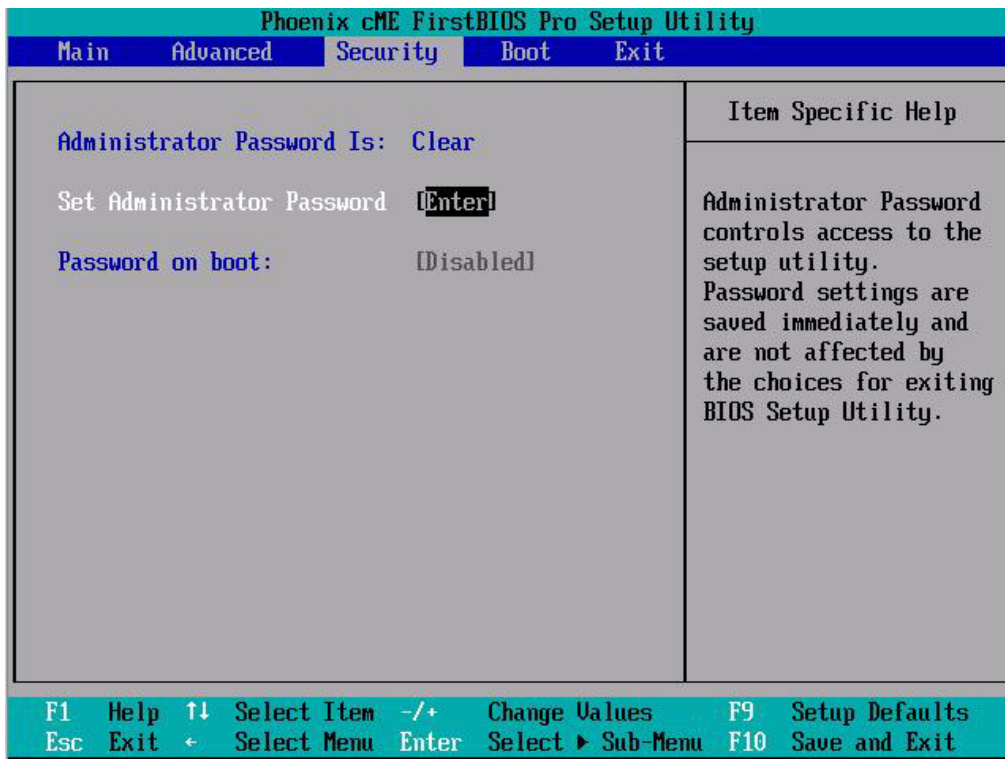
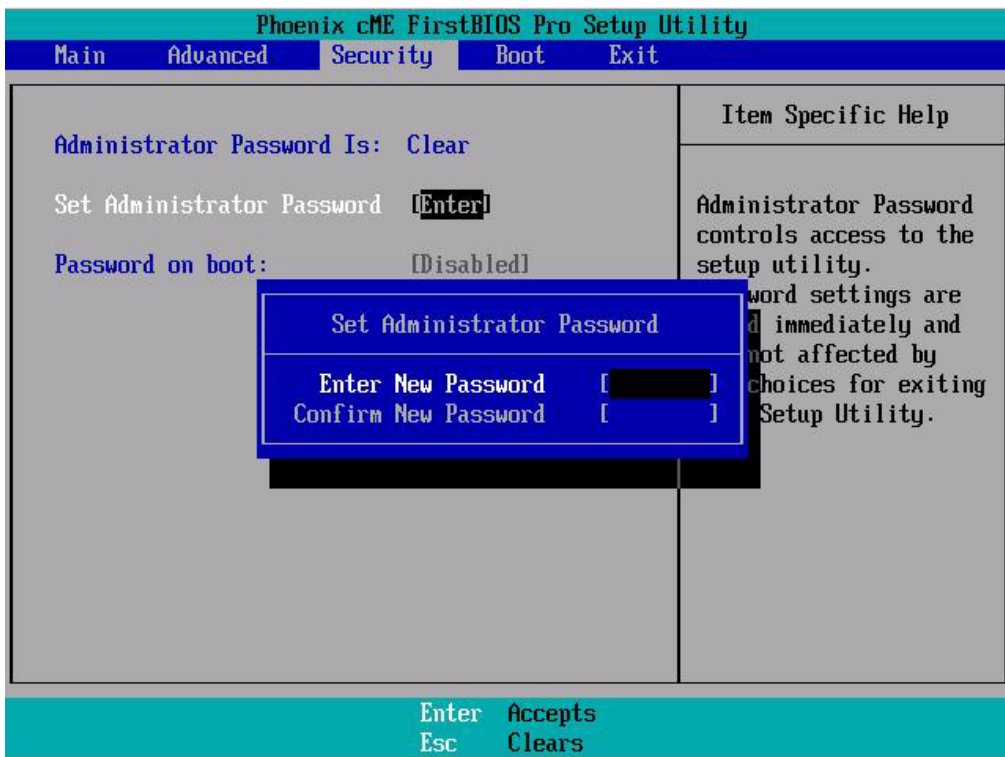

Figure 4-7 Security menu of the BIOS Setup Utility 2



Use this menu to configure the following items:

- **Administrator Password Is** – Display if an administrator password is set.
- **Set Administrator Password** – Allows you to access and change all settings in the Setup Utility. The administrator password allows you to configure access for system users.
- **Password on boot** – If an administrator password has been set, use this item to enable or disable the requirement of the administrator password when booting the server.

To set a new administrator password:

1. In the Security screen, select a set password field - **Set Administrator Password**, and then press **Enter**.
2. Type a new password in the **Enter New Password** box.

3. The password may consist of up to eight alphanumeric characters (A-Z, a-z, 0-9).
4. Retype the password to verify the first entry, and then press **Enter**.
5. Press **F10** to close the Setup Utility.
6. After setting the password, Setup automatically sets the selected password field to **Enabled**.

Boot Menu

Figure 4-8 Boot menu of the BIOS Setup Utility

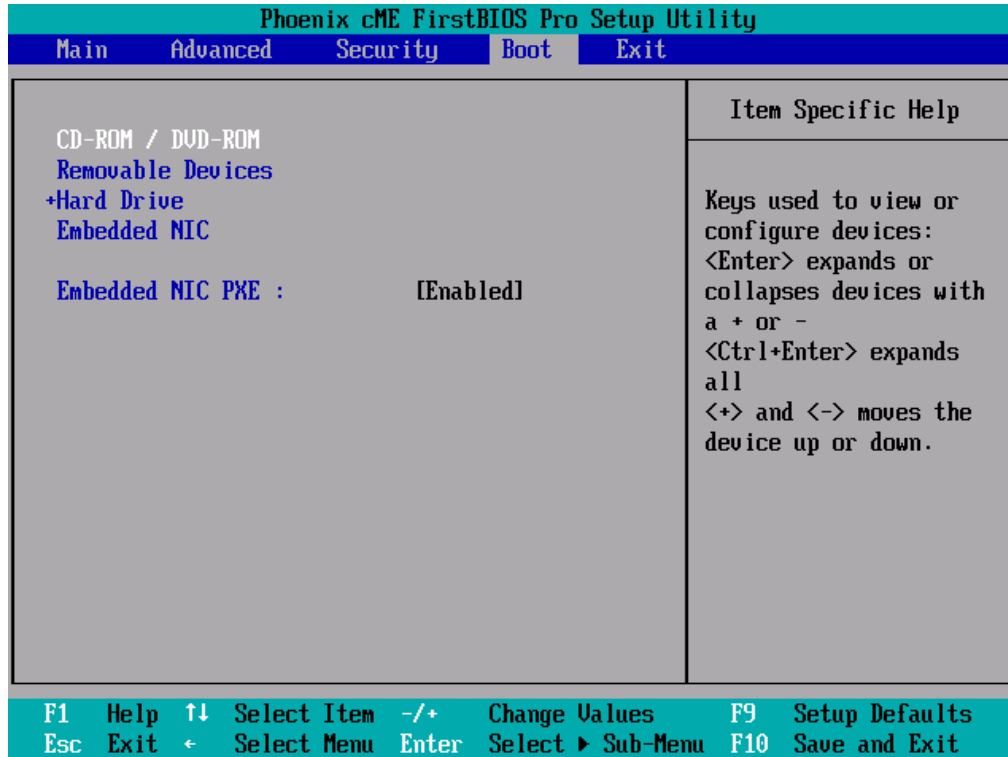

Use this menu to configure the boot priority.

Set boot device priority. By default, the server searches for boot devices in the following order:

1. CD-ROM/DVD-ROM drives
2. Removable devices
3. Hard drive
4. Embedded NIC

Exit Menu

Figure 4-9 Exit menu of the BIOS Setup Utility

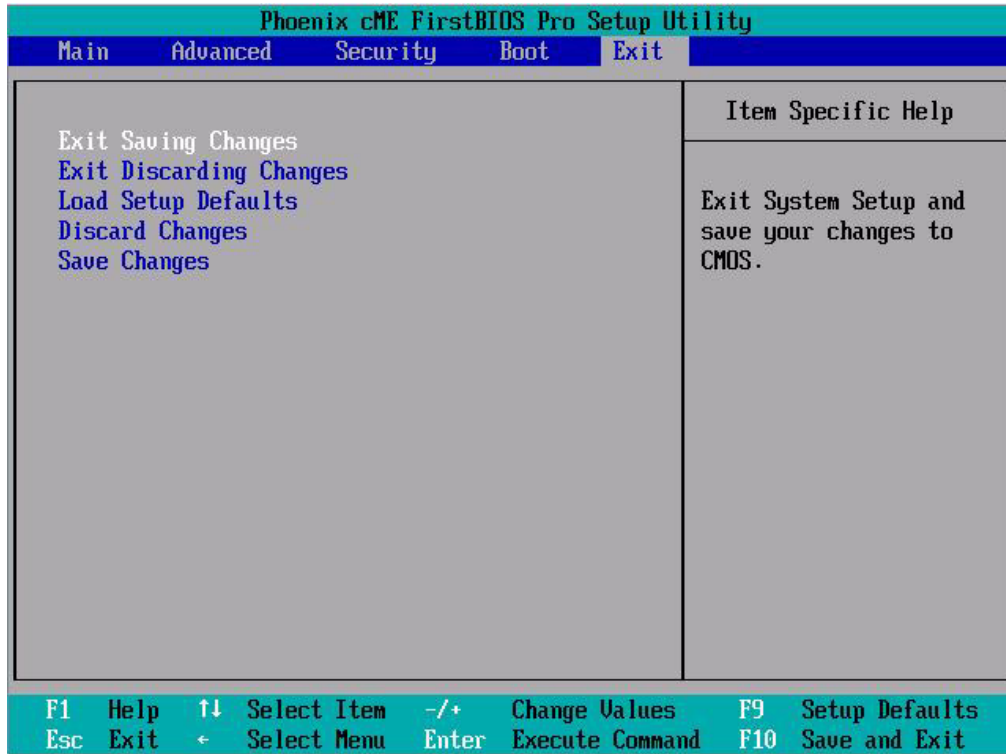

Use this menu to save changes or discard changes. When you exit, the server reboots.

- **Exit Saving Changes** -- Save the changes you have made and exit the BIOS Setup Utility. (You can also press **F10** key.)
- **Exit Discarding Changes** -- Exit the BIOS Setup Utility without saving the changes you have made. (You can also press **Esc** key.)
- **Load Setup Defaults** -- Load the factory default values for all items. (You can also press the **F9** key.)
- **Discard Changes** -- Discard any changes you have made.
- **Save Changes** -- Save the changes you have made.

BIOS Update

Perform the steps below to update BIOS:

1. Download the Smart Component (SPxxxxx.exe) to a directory on your hard drive.
2. Execute (SPxxxxx.exe) and followed with direction to complete the steps. "ProLiant Flash Update" interface will appear.
3. Select items which need to update:
 - Create a bootable ROMPAQ diskette
 - Create a bootable ROMPAQ USB Key
 - Create a bootable ROMPAQ CD
 - ROMPAQ Diskette Flat Files
 - Create a label for the ROMPAQ diskette
 - Network ROM Flashing Capabilities
4. Reboot ML110 Generation 4 Server with one of the above bootable devices and make sure the BIOS setting allows booting from the USB disk.
5. Follow the on-screen instructions to finish the flashing of the BIOS.

Clear CMOS

You may need to clear the Setup configuration values (CMOS) if the configuration has been corrupted, or if incorrect settings made in the Setup Utility have caused error messages to be unreadable.

To clear CMOS:

1. Perform the pre-installation instructions listed in Chapter 3.
2. If necessary, remove any accessory boards or cables that prevent access to the system configuration switch.
3. Locate the system configuration button (SW2) on the system board.
4. Press the button. AC power must not be connected.
5. Perform the post-installation instructions listed in Chapter 3.
6. During POST, press **F10** to access the Setup Utility.
7. Load setup defaults by pressing **F9**.
8. Set time, date, and other system values.
9. Press **F10** to close the Setup Utility.



NOTE: Clearing CMOS deletes all system configurations and password settings.

Power-On Self-Test (POST)

Before you can use a server, all devices must be tested and initialized, and the operating system must be bootstrapped to the memory. This is referred to as Power-On Self-Test or POST. POST is a series of diagnostic tests that checks firmware and hardware components on the system to ensure that the server is properly functioning. This diagnostic function automatically runs each time the server is powered on.

These diagnostics, which reside in the BIOS ROM, isolate server-related logic failures and indicate the board or component that you need to replace, as indicated by the error messages. Most server hardware failures will be accurately isolated during POST. The number of tests displayed depends on the configuration of the server.

During POST you can:

- Press **ESC** to skip the HP logo and go to POST boot progress display system summary screen.
- Press **F7** to display the Boot menu.
- Press **F10** to access the Setup Utility.
- Press **F12** to request a network boot (PXE).

POST Error Indicators

When POST detects a system failure, it displays a POST error message.

Recoverable POST Errors

Whenever a non-fatal error occurs during POST, an error message describing the problem appears onscreen. These error messages are displayed in normal video (white text on black background), and show the details of the error. The following is an example of a POST error message:

```
0271 - Check date and time settings
```

Table 4-2 lists the most common POST error messages with corresponding troubleshooting recommendation. HP recommends that you correct the error, even if the server appears to boot successfully.

Table 4-2 POST Error Messages

Error Code	Error Message	Description / Corrective Action
0200	Failure fixed disk	A fixed disk did not respond. Remove A/C power momentarily then try again. If this does not resolve the error, an unrecoverable hardware error has occurred.
0210	Stuck key	A key on the keyboard is stuck down. Release the key or replace the keyboard.
0211	Keyboard error	The keyboard did not respond. If the error continues, replace the keyboard.
0212	Keyboard controller failed	Try a different keyboard. If the error persists, main board replacement may be required.
0213	Keyboard locked - Unlock key switch	A keyboard with a lock option is reporting that the lock is active.
0250	System battery is dead - Replace and run SETUP	The CMOS battery is discharged. It must be replaced.

Table 4-2 POST Error Messages

Error Code	Error Message	Description / Corrective Action
0260	System timer error	The 8254 timer did not respond as expected. Main board replacement may be required.
0270	Real time clock error	The real time clock did not respond. Main board replacement may be required.
0271	Check date and time settings	The system date or time is invalid. If the error returns after resetting date and time, CMOS battery replacement may be required.
0280	Previous boot incomplete - Default configuration used	Setup changes were not saved because of a boot failure. Reapply setup changes and boot again.
02D0	System cache error - Cache disabled	A processor reported an uncorrectable cache error. Replacement is required.
0230	System RAM Failed at offset:	An uncorrectable memory error has occurred. Replace memory modules.
0231	Shadow Ram Failed at offset:	An uncorrectable memory error has occurred. Replace memory modules.
0232	Extended RAM Failed at address line:	An uncorrectable memory error has occurred. Replace memory modules.
0251	System CMOS checksum bad - Default configuration used	CMOS memory has been corrupted. This message is normal after the CMOS battery is replaced.
02F5	DMA test failed	The DMA controller did not respond. Main board replacement may be required.
02F9	CPU Fan error	The CPU Fan did not respond. Replace the CPU Fan.
02FA	Rear Fan error	The Rear Fan did not respond. Replace the Rear Fan.

POST Related Troubleshooting

Perform the following procedures when POST fails to run, displays error messages, or emits beep codes.

If the POST failure is during a routine boot up, check the following:

- All external cables and power cables should be firmly plugged in.
- The power outlet to which the server is connected and is working.
- The server and monitor are both turned on. The bicolour status LED indicator on the front panel must be lit up green.
- The monitor's contrast and brightness settings are correct.
- All internal cables are properly connected and all boards firmly seated.
- The processor is fully seated in its socket on the system board.
- The cooler assembly is properly installed on top of the processor.
- All memory modules are properly installed.
- If you have installed a PCI accessory board, verify that the board is firmly seated and any switches or jumpers on the board are properly set. Refer to the documentation provided with the accessory board.
- All internal cabling and connections are in their proper order.
- If you have changed any switches on the system board, verify that each is properly set.

5 Connectors, switches and LEDs

This chapter contains illustrations and tables identifying and describing the connectors, switches, buttons, and LED indicators located on the front panel, rear panel, system board and hard drives of the HP ProLiant ML110 Generation 4 server.

Connectors and components

This section contains illustrations and tables identifying connectors and components on the front and rear panels of the server, as well as those located on the system board.

Front panel components

Figure 5-1 Front panel components

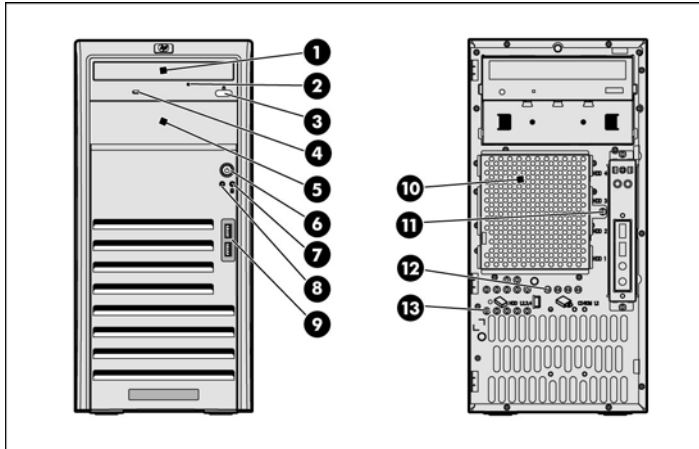

- | | | | |
|---|----------------------------------|----|-----------------------------|
| 1 | Optical drive | 8 | Drive activity indicator |
| 2 | Optical drive manual eject hole | 9 | Front USB 2.0 ports |
| 3 | Optical drive eject button | 10 | Hard drive EMI shield |
| 4 | Optical drive activity indicator | 11 | Hard drive EMI shield screw |
| 5 | Half-height common bay | 12 | Optical drive spare screws |
| 6 | Power button | 13 | Hard drive spare screws |
| 7 | Power LED indicator | | |

Rear panel components

Figure 5-2 Rear panel components

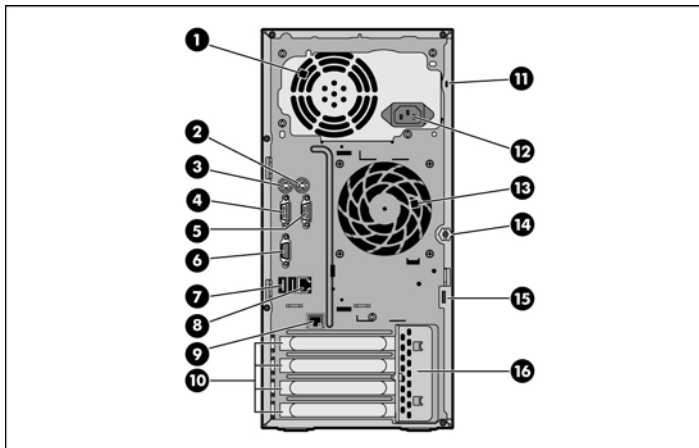

- | | | | |
|---|-----------------|----|--|
| 1 | PSU fan | 9 | IPMI card (HP LO 100c Remote Management Card) port |
| 2 | PS/2 mouse port | 10 | PCI slot covers |

- 3 PS/2 keyboard port
- 4 Serial port B
- 5 Serial port A
- 6 VGA port
- 7 Rear USB 2.0 ports
- 8 LAN port (RJ-45)
- 11 Kensington lock notch
- 12 Power supply outlet
- 13 Rear system fan
- 14 Thumbscrew for access panel
- 15 Cable lock provision tab
- 16 PCI expansion slot cover lock

System board components

Figure 5-3 System board components

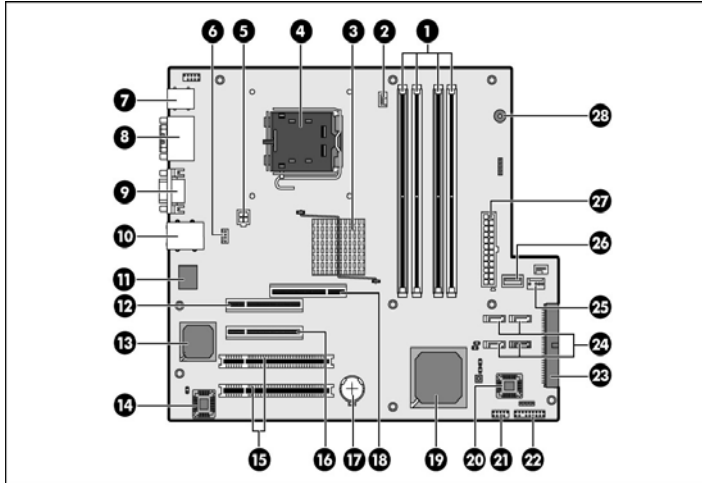

Table 5-1 System board components

Item	Component Code	Description
1	DIMM1 - 4	DDRII slots
2	P70	4-pin CPU fan connector
3	U3	Intel® MuliTeo 2 (MCH)
4	XU1	Intel® LGA775 CPU socket
5	P3	4-pin ATX CPU power connection
6	P8	4-pin system fan connection (rear)
7	J68	Top: PS/2 mouse port Bottom: PS/2 keyboard port
8	P53	Serial port A Serial port B
9	J69	VGA port
10	J9	Top: LAN port Bottom: USB 2.0 ports
11	U1033	Broadcom 5721 GbE chip
12	J32	PCI-Express x 8 line with x 8 slot
13	U11	Server Engines Chip
14	J5	SMC FW
15	J20, J21	32-bit/33-MHz 3.3V PCI bus slot
16	J33	PCI-Express x 4 line with x 8 slot
17	XBT2	Battery
18	J10	IPMI card (HP LO 100c Remote Management Card) slot
19	U38	Intel® ICH7R

Table 5-1 System board components

Item	Component Code	Description
20	J2	System BIOS
21	P24	Front USB connector
22	P5	Front panel connector
23	P23	IDE channel UDMA-100
24	P60, P61,P62,P64	SATA 1-4 connector
25	J4	Internal USB connector for Tape
26	J3	Internal USB connector
27	P2	24-pin ATX system board power connector
28	SP1	Internal buzzer

Jumpers – Password and Boot Block

The system board password (P137) and boot block (P136) jumpers. Table 5-2 describes the jumper settings.

Table 5-2 System configuration switch settings

Jumper	Status	Function
P137	On (default)	Password enabled.
	Off	Password reset/disabled.
P136	On	Boot block unprotected.
	Off (default)	Boot block protected.

Clear CMOS button

The system board has a system configuration (CMOS) button (SW50). To clear system configuration, disconnect AC power and press the CMOS button.

Status LED indicators

This section contains illustrations and descriptions of internal and external status LED indicators located on the:

- Front panel
- Rear panel
- System board

These LED indicators aid in problem diagnosis by indicating the status of system components and operations of the server.

Front panel LED indicators

The front panel LED indicators allow constant monitoring of basic system functions while the server is operating.

Optical drive activity LED indicator

The optical drive has an activity indicator that indicates when the drive is reading media.

Figure 5-4 Optical drive activity LED indicator location

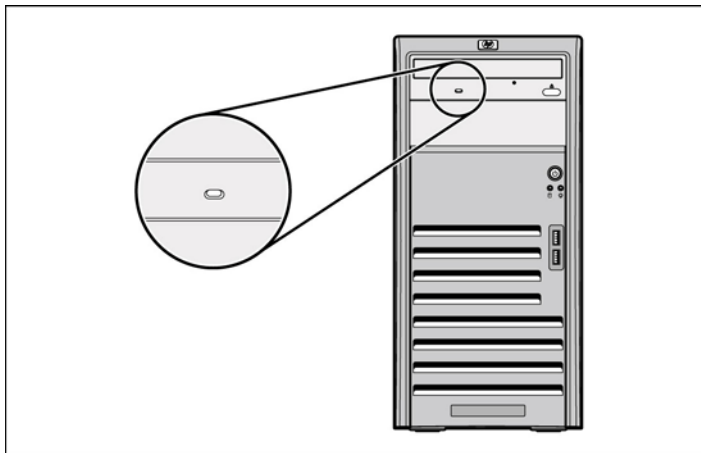

Activity states for the optical drive are as follows:

- Flashing green – Ongoing drive activity
- Off – No drive activity

Power/system health LED indicator

The power status and health condition of the server is indicated by the bicolor LED indicator found on the front panel.

Figure 5-5 Power/system health LED indicator location

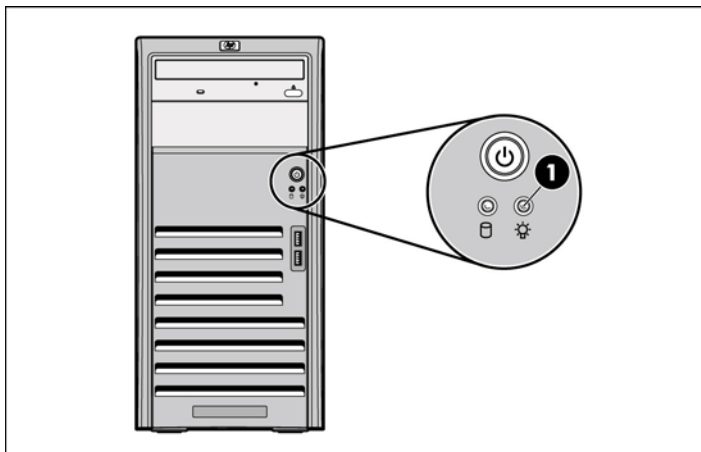

Table 5-3 Power/system health LED indicator status

Component	Status	Description
Power/system health LED indicator	Steady green	The server is operating normally.
	Steady Amber	The server is shut down, but with A/C power plugged in or the server hibernates.
	Off	The server is system off without A/C power.

Hard drive activity LED indicators

The status of hard drives installed in the server is indicated by the drive activity LED indicator located on the front panel of the server.

Figure 5-6 Drive activity LED indicator

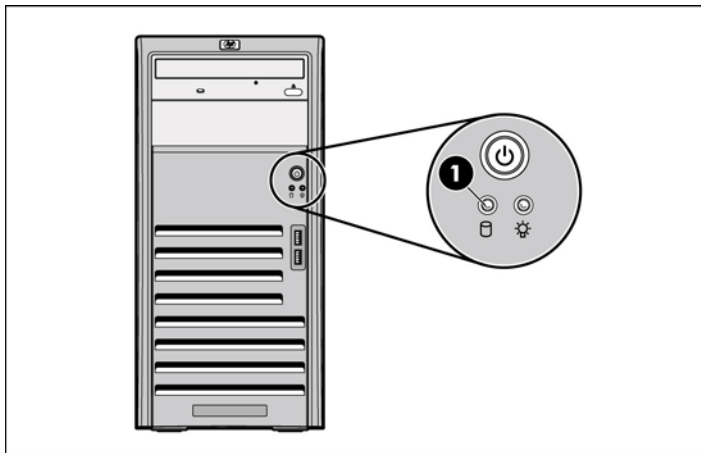

Activity states for hard drives are as follows:

- Flashing green – Ongoing drive activity
- Off – No drive activity

Rear panel LED indicators

The LAN port on the rear panel has two LED indicators that allow monitoring of network activity.

Figure 5-7 LAN/LED indicators location

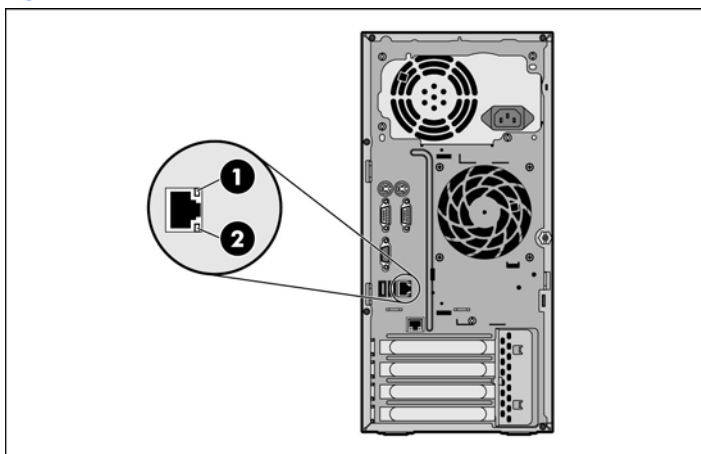

Table 5-4 LAN/LED indicator states

Item	Component	Status	Description
1	LAN activity status LED indicator	Flashing green	Ongoing network data activity.
		Off	No network data activity or no connection.
2	LAN network speed LED indicator	Steady green	The LAN connection is using a GbE link.
		Steady amber	The LAN connection is using a 100 Mbps link.
		Off	The LAN connection is using a 10 Mbps link or no connection.

System board LED indicators

The system board contains three internal status LED indicators for use during troubleshooting operations.

Figure 5-8 System board LED indicators

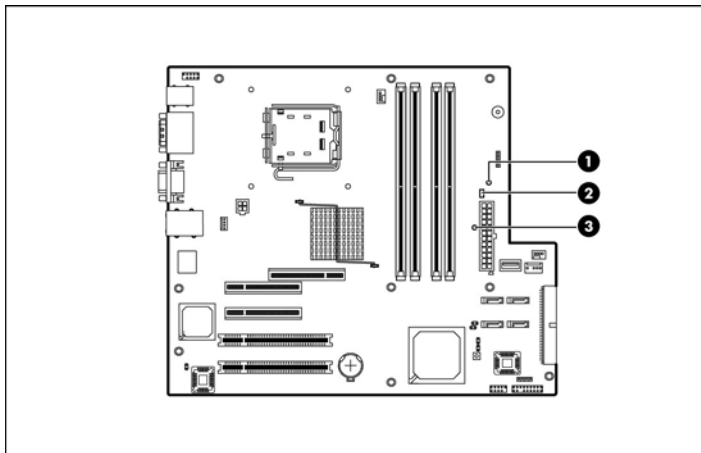

Table 5-5 System board LED indicators

Item	Component	Status	Description
1	5V aux power indicator (CR1)	Green	Auxiliary power present.
2	3.3V aux power indicator (CR2)	Off	The server is powered off (AC power disconnected).
3	System Error Indicator (CR7)	Red	A system error has occurred.
		Off	System is operating under normal condition.

6 Physical and operating specifications

This chapter provides physical and operating specifications for the HP ProLiant ML110 Generation 4 server. Specifications include:

- System unit
- Memory
- Processor
- IDE CD-ROM drive
- SAS hard drive
- SATA hard drive
- SAS storage controller

System unit

Table 6-1 Hardware specifications

Item	Component
Processor socket	Intel® LGA775
Processor support	Intel® Pentium® 4 processor Intel® Pentium® -D processor Intel® Celeron® -D processor Intel® Xeon® 3000 series processor
Chipset	Intel® 3000/3010 chipset Intel® ICH7R
Super I/O chipset	Integrated in the Server Engines Chip
Hardware monitoring device	Integrated in the Server Engines Chip
Gigabit Ethernet controller	Broadcom 5721 GbE LAN Chip
Memory controller	Integrated in the Intel® 3000/3010 chipset
SATA and IDE controllers	Integrated in the Intel® ICH7R
VGA controller	Integrated in the Server Engines Chip
I/O subsystem	<ul style="list-style-type: none"> • One PCI-E x8 slot • One PCI-E x4 line with x8 slot • Two 3.3V 32-bit/33-MHz PCI bus slots
Memory	Four DDR II DIMM slots
Storage Bay	<ul style="list-style-type: none"> • Two half-height storage bays for CD-ROM drive, tape drive • Four 3.5-in bay for non-hot plug SAS or non-hot plug SATA HDD
I/O ports	One PS/2 port (keyboard/mouse), Six USB 2.0 ports (two front ports, two rear ports, and two internal connectors), One video port, Two serial ports, and One GbE LAN port.
Status LED indicators	
Front panel	<ul style="list-style-type: none"> • Power/system health status • Hard drive activity
Rear panel	<ul style="list-style-type: none"> • LAN activity • LAN link status
System board	<ul style="list-style-type: none"> • Auxiliary power indicators • Processor IERR indicator
Power supply unit (PSU)	Delta DPS-370AB-1A (370 watts)
Thermal solution	<ul style="list-style-type: none"> • One system fan • One processor cooler

Table 6-2 Software specifications

Item	Description
Network operating system (NOS) support	<ul style="list-style-type: none"> • Microsoft Windows Server 2003 Standard Edition • Microsoft Windows Server 2003 Standard x64 Edition • Microsoft Windows Server 2003 R2 Standard Edition • Microsoft Windows Server 2003 R2 Standard x64 Edition • Microsoft Windows Small Business Server 2003 • Microsoft Windows Server 2003 Web Edition • Microsoft Windows XP Professional • Microsoft Windows XP Professional x64 Edition • Microsoft Windows 2000 Server • Red Hat Enterprise Linux 4 AS (x86) • Red Hat Enterprise Linux 4 AS (AMD64/EM64T) • Red Hat Enterprise Linux 3 AS (x86) • Red Hat Enterprise Linux 3 AS (AMD64/EM64T) • SUSE Linux Enterprise Server 9 (x86) • SUSE Linux Enterprise Server 9 (AMD64/EM64T)
System diagnostics	<ul style="list-style-type: none"> • Phoenix BIOS Setup Utility • HP Insight Diagnostics

Table 6-3 Physical dimension

Item	Description
System board platform	ATX (Advanced Technology Extended)
System board dimensions Length Width	244 mm (9.6 in) 289 mm (11.36 in)
Server dimensions Height Width Length	367 mm (14.5 in) 175 mm (6.9 in) With bezel – 426 mm (16.8 in) Without bezel – 386 mm (15.2 in)
Server weight	<ul style="list-style-type: none"> • Basic configuration (excludes keyboard and mouse) – approximately 10 kg (22 lb) • Fully loaded configuration (includes keyboard, mouse, kits and USB Floppy in the box) – approximately 17.5 kg (39 lb)

Table 6-4 Environmental specifications

Item	Description
<u>Temperature range:</u> Operating Shipping	10°C to 35°C (50°F to 95°F) -30°C to 60°C (-22°F to 140°F)
<u>Relative humidity:</u> Operating Non-operating	10% to 90% 10% to 95%
<u>Acoustic noise:</u> Idle (Fixed disk drives spinning) L Wad (BELS) L pA (dBA) Operating (Random seeks to fixed disks) L Wad (BELS) L pA (dBA)	5.5 38 6.0 43

Table 6-5 Power supply specifications

Item	Description
Dimensions (D x H x W) (with feet)	150 mm x 140 mm x 86 mm (5.9 in x 5.5 in x 3.4 in)
Weight (approximate)	1.7 kg (3.75 lb)
<u>Input requirements:</u> Rated input voltage Normal line voltage	100-127VAC/200-240VAC 115VAC, 230VAC
Line frequency	47 to 63 Hz
Rated input current	Load 8A at 100-127VAC, 4A at 200-240VAC
BTU rating	1262.5 BTU(output), 1781.7BTU(input)
<u>Power supply output power:</u> Rated steady state power Maximum peak power	370W 370W
<u>Temperature range:</u> Operating Shipping	+10°C to +50°C -40°C to +70°C
<u>Relative humidity:</u> Operating Non-operating	5% to 95% non-condensing at degree +40°C <=90% for a period of twenty-four hours at degree +60°C

Memory

Table 6-6 Memory specifications

Item	Description
Size	512-MB, 1-GB, 2-GB
Speed	PC2-5300
Type	Unbuffered ECC DDRII DIMM

Processor

The server Intel® LGA775 processor socket in HP ProLiant ML110 Generation 4 server supports Intel® Pentium® 4, Intel® Pentium®-D, Celeron®-D processors and Xeon® 3000 series processors.

Table 6-7 Intel® Pentium® 4 processor specifications

Operating Frequency	FSB Speed	On-die L2 Cache	Voltage	Package
2.8 GHz	800 MHz	2 MB	1.4	775FC-LGA4
3.0 GHz	800 MHz	2 MB	1.4	775FC-LGA4
3.2 GHz	800 MHz	2 MB	1.4	775FC-LGA4
3.4 GHz	800 MHz	2 MB	1.4	775FC-LGA4
3.6 GHz	800 MHz	2 MB	1.4	775FC-LGA4

Note: The server supports Intel® Pentium® 4 processors with HT (Hyper-Threading) technology.

Table 6-8 Intel® Pentium® -D processor specifications

Operating Frequency	FSB Speed	On-die L2 Cache	Voltage	Package
2.8 GHz	800 MHz	2x2 MB	1.4	775FC-LGA4
3.0 GHz	800 MHz	2x2 MB	1.4	775FC-LGA4
3.2 GHz	800 MHz	2x2 MB	1.4	775FC-LGA4
3.4 GHz	800 MHz	2x2 MB	1.4	775FC-LGA4

Table 6-8 Intel® Pentium® -D processor specifications

Operating Frequency	FSB Speed	On-die L2 Cache	Voltage	Package
3.6 GHz	800 MHz	2x2 MB	1.4	775FC-LGA4

Note: The server supports Intel® Pentium® -D processors with dual core technology.

Table 6-9 Intel® Celeron® -D processor specifications

Operating Frequency	FSB Speed	On-die L2 Cache	Voltage	Package
2.53 GHz	533 MHz	512 KB	1.4	775FC-LGA4
2.93 GHz	533 MHz	512 KB	1.4	775FC-LGA4
3.06 GHz	533 MHz	512 KB	1.4	775FC-LGA4
3.2 GHz	533 MHz	512 KB	1.4	775FC-LGA4
3.33 GHz	533 MHz	512 KB	1.4	775FC-LGA4

Note: The server supports Intel® Celeron® -D processors with Execute Disable Bit capability.

Table 6-10 Intel® Xeon® 3000 series processor specifications

Operating Frequency	FSB Speed	On-die L2 Cache	Voltage	Package
1.86 GHz	800 MHz	4 MB	1.3	775FC-LGA4
2.13 GHz	800 MHz	4 MB	1.3	775FC-LGA4
2.40 GHz	1066 MHz	4 MB	1.3	775FC-LGA4
2.66 GHz	1066 MHz	4 MB	1.3	775FC-LGA4
1.86 GHz	1066 MHz	2 MB	1.3	775FC-LGA4
2.13 GHz	1066 MHz	2 MB	1.3	775FC-LGA4
2.40 GHz	800 MHz	2 MB	1.3	775FC-LGA4

Note: The server supports Intel® Xeon® 3000 series processors with HT (Hyper-Threading) technology.

IDE CD-ROM drive

Table 6-11 IDE CD-ROM specifications

Item	Description
Form factor	5.25 in, half-height
Dimensions	
Height	41.3 mm (1.6 in)
Width	146 mm (5.8 in)
Depth	184.7 mm (7.3 in)
Weight	0.72 kg (1.6 lb)
Supported disc formats	<ul style="list-style-type: none"> Mixed Mode (audio and data combined) CD-DA, Mode 1 (basic format), Mode 2, Form 1 and Form 2 Photo-CD (multi-session), CD-XA CD-I, CD-Plus/CD-Extra, CD-RW
Rotational speed	20x to 48x
Data capacity	
Mode 1 and Mode 2, Form 1	2,048 bytes/block
Mode 2	2,340/2,336 bytes per block
Mode 2, Form 2	2,332 bytes/block
CD-DA	2,352 bytes/block
Data buffer capacity	128-KB

Table 6-11 IDE CD-ROM specifications

Item	Description
Data transfer rate Sustained Burst	<ul style="list-style-type: none"> • 20X (inner side) – 3,000 KB/s • 48X (outer side) – 7,200 KB/s • PIO Mode 4 – 16.67 MB/s • Multi-DMA Mode – 16.67 MB/s • UDMA Mode 2 – 33.3 MB/s
Average access time Typical Maximum	75 ms 100 ms
Three-way eject support	<ul style="list-style-type: none"> • Using software • Using drive open/close button • Using emergency eject hole
Operating conditions Temperature Relative humidity	0°C to 50°C (32°F to 122°F) 5% to 90%

SAS hard drive

Table 6-12 SAS hard drive specifications

Item	36-GB Drive	72-GB Drive	146-GB Drive
Capacity	36 GB	72 GB	146 GB
Height	1 in	1 in	1 in
Width	4 in	4 in	4 in
Interface	SAS	SAS	SAS
Transfer Rate	300 MB/s	300 MB/s	300 MB/s
Rotational Speed	15,000 RPM	15,000 RPM	15,000 RPM
Bytes per sector	685 to 1142 MBps	685 to 1142 MBps	685 to 1142 MBps
Operating Temperature	5°C to 55°C	5°C to 55°C	5°C to 55°C

SATA hard drive

Table 6-13 SATA hard drive specifications

Item	Description
Capacity	80-GB
Dimensions (maximum) Height Width Depth	26.1 mm (1.03 in) 101.6 mm (4.0 in) 147 mm (5.8 in)
Weight	0.63 kg (1.4 lb)
Interface	Ultra ATA/150
Maximum transfer rate	150 MB/s
Rotational speed	7200 RPM
Bytes per sector	512
Sectors per drive	160,086,528
Operating temperature	5°C to 55°C (41°F to 131°F)

SAS storage controller

Table 6-14 SAS storage controller specifications

Item	Description
Processor	LSISAS1068
Form factor	Lower-profile PCI-X
Interface type	PCI-X/ 133 MHz 64-bit
Controller interface	1.5 Gb/s and 3.0 Gbit/s SAS 1.5 Gbit/s SATA
Dimensions	
Height	63.5 mm (2.5 in)
Depth	167.6 mm (6.6 in)
Data transfer rate	1064 MB/s
Supported devices	Hard drive, disk array (RAID)
Number of channels	Two Internal x4 right angle SAS connector with 4 sideband lines
Maximum number of supported storage devices	15
Standard compliance	EMC Class-B
Operating conditions	
Temperature	0°C to 60°C
Relative humidity	5% to 90%

Index

A

AC power: disconnecting, warning, 23, 45; power-down procedures, 23
access panel: part number, 14; reinstalling, 24; removing, 23
AMIBIOS Setup Utility: BIOS settings loss, 41
ATX: Advanced Technology Extended. See system board, platform

B

battery: location, 41; replacement warnings, 41; replacing, 41
BIOS Setup Utility: accessing, 46; additional navigation keys, 46; menu bar, 46
BIOS software: Overview, 46
blank bezel: part number, 14

C

cable connections, 26
cable management, 25
cautions: ESD, 21; improper airflow, 23; power fluctuations, 23; proper cooling, 23
CD-ROM drive: cable assembly, part number, 17
CD-ROM drive specifications, 65
component-level repairs, warnings, 21
cooler: part number, 17; removing, 32; replacing, 34
cooling, caution, 23

D

Diagnostic tools and Setup Utilities: BIOS Setup Utility, 46; BIOS software, 46; BIOS update, 53; clear CMOS, 53; POST, 54
DIMM: part number, 17; slots, 35
DIMM specifications: size, 64; speed, 64; type, 64
drive bay configuration: optical drive, 27; optional media device, 28; overview, 26
drive latch, 31; installing, 31; removing, 31
drive release latch: part number, 14
drive shield: part number, 14
drives: cable connections, 26; cable management, 25; drive latch, 31; hard drives, 29; releasing drives, 27

E

electrostatic discharge. See ESD
environmental specifications, 63
ESD: damage precautions, 21; work area recommendations, 21
expansion card: PCI card, 36; stargazer card, 39
expansion slot cover lock: part number, 14

F

front bezel: part number, 14; reinstalling, 24; removing, 24
front panel components, 56

H

hard drive: removing, 29; screw location, 31
hard drive EMI shield: part number, 14
hard drives, 29
hardware configuration: access panel, 23; battery, 41; ESD damage prevention, 21; expansion cards, 36; front bezel, 24; memory, 35; optical drive, 27; optional media device, 28; post-installation procedures, 22; power supply unit, 42; pre-installation procedures, 22; processor, 32; symbols in equipment, 21; system fan, 43; tools, 21
hardware monitoring: onboard controller, 62
hardware specifications, 62; chipset, 62; hardware monitoring controller, 62; I/O ports, 62; I/O subsystem, 62; LAN controller, 62; memory, 62; optional media storage, 62; power supply unit, 62; processor socket, 62; processor support, 62; super I/O chipset, 62; thermal solution, 62; VGA controller, 62
hazardous conditions. See symbols on equipment
height, 63
hot surface: warning, 23
HP: authorized reseller, 19; contact information, 20; technical support, 20; technical support requirements, 20
HP Lights-Out 100c Remote Management Card: part number, 17

I

I/O subsystem, 62
IDE CD-ROM drive: part number, 17
IPMI Card: installing, 45; system board location, 45
IPMI card bracket dummy: part number, 14
IPMI card installing (HP Lights-Out 100c remote management card): defined, 45

L

labels. See symbols on equipment
LAN controller, 62
length, 63; with bezel, 63; without bezel, 63

M

mass storage devices: drive bay configuration, 26; part number, 17
media storage: optional, 62
memory controller, 62
memory modules: DIMM slots, 35; guidelines for installation, 35; installing, 36; module orientation, 36; removing, 35; specifications, 64
Misc plastics kit/hardware kit: part number, 14

N

network operating system. See NOS support
non-hot-plug device, 21
NOS support, 63

O

onboard controllers: LAN, 62; memory controller, 62; storage controller, 62; VGA, 62
optical drive: activity indicator, 58; installing, 28; replacing, 27
optical drive shield: removing, 29
optional media device: installing, 28

P

parts: illustrated catalog, 14; storing, 21; transporting, 21
PCI card, 36; installing, 38; removing, 37
PCI devices: bus channels, 36; PCI chipset, 62; PCI slots, 37

PCI expansion cards: PCI slots, 37
PCI guide: reinstalling, 40;
removing, 39
PCI slot cover lock: removing, 37;
replacing, 38
Peripheral Component Interconnect.
See PCI devices
personal injury, warning, 23
physical dimensions, 63; server, 63;
system board, 63
power fluctuations, caution, 23
power supply: specifications, 64
power supply unit. See PSU
power supply unit with cable
assembly: part number, 17
power/system health LED indicator,
59
power-down procedures, 23
Power-On Self Test: POST error
indicators, 54; POST related
troubleshooting, 55; recoverable
POST errors, 54
processor: applying thermal grease,
33; installing, 34; overheating
prevention, 34; part number, 17;
removing, 33; socket location, 32;
specifications, 64; thermal patch,
33
processor cooler. See cooler
processor socket: specification, 62
PSU: installing, 42; removing, 42;
replacement warnings, 42; type,
62

R

rear panel components, 56
releasing drives, 27
removable media device: installing,
28; supported devices, 28

S

SAS card: part number, 17
SAS hard drive: cable, part number,
17; specifications, 66
SAS storage controller specifications,
67
SAS/SATA hard drive: part number,
17
SATA hard drive: cable, part
number, 18; specifications, 66
server dimensions: height, 63;
length, 63; width, 63
Setup Utility menu bar: advanced
menu, 49; boot menu, 52; exit
menu, 53; main menu, 48; security
menu, 50
software specifications, 63; NOS,
63; system diagnostics, 63
specifications: physical and
operating, 62; processor, 64
standby mode: effects, 23
stargazer card, 39; installing, 40;
location, 39
status LEDs: HDD activity, 59; LAN,
60; optical drive activity, 58;
power/system health, 59; system
board LEDs, 60
storage controller, 62
super I/O chipset, 62
symbols on equipment, 21
system board: components, 57;
configuration, 32; dimensions, 63;
layout, 57; LEDs, 60; part number,
17; platform, 63
system covers: access panel, 23;
front bezel, 24
system fan: installing, 43; part
number, 17; removing, 43;
replacement warning, 43

system health: hardware monitoring
chipset, 62
system LEDs. See status LEDs
system structure: front panel, 56; rear
panel, 56; system board, 57

T

thermal grease: caution, 34
thermal patch, 33
thermal solution, 62

U

uninterruptible power supply. See
UPS
UPS, 23
USB/Power LED cable: part number,
18

V

VGA controller, 62

W

warnings: battery replacement, 41;
component-level repairs, 21; hot
surface, 23; improper repairs, 21;
personal injury, 23; PSU
replacement, 42; system fan
replacement, 43; technician notes,
21
weight: basic configuration, 63; full
configuration, 63
width, 63
work area recommendations, 21